

NASA Technical Memorandum 104001

---

# Jet-Induced Ground Effects on a Parametric Flat-Plate Model in Hover

---

Douglas A. Wardwell and Craig E. Hange, Ames Research Center, Moffett Field, California  
Richard E. Kuhn and Vearl R. Stewart, KSA Technology, Columbus, Ohio

March 1993



National Aeronautics and  
Space Administration

**Ames Research Center**  
Moffett Field, California 94035-1000



# Jet-Induced Ground Effects on a Parametric Flat-Plate Model in Hover

DOUGLAS A. WARDWELL, CRAIG E. HANGE, RICHARD E. KUHN,\* and VEARL R. STEWART\*

Ames Research Center

## Summary

The jet-induced forces generated on short takeoff and vertical landing (STOVL) aircraft when in close proximity to the ground can have a significant effect on aircraft performance. Therefore, accurate predictions of these aerodynamic characteristics are highly desirable. Empirical procedures for estimating jet-induced forces during the vertical/short takeoff and landing (V/STOL) portions of the flight envelope are currently limited in accuracy. The jet-induced force data presented in this report significantly add to the current STOVL configurations data base. Further development of empirical prediction methods for jet-induced forces, to provide more configuration diversity and improved overall accuracy, depends on the viability of this STOVL data base. The data base may also be used to validate computational fluid dynamics (CFD) analysis codes.

This report presents the hover data obtained at the NASA Ames Jet Calibration and Hover Test (JCAHT) facility for a parametric flat-plate model. The model tested was designed to allow variations in the planform aspect ratio, number of jets, nozzle shape, and jet location. There were 31 different planform/nozzle configurations tested. Each configuration had numerous pressure taps installed to measure the pressures on the undersurface of the model. All pressure data, along with the balance jet-induced lift and pitching-moment increments, are tabulated. For selected runs, pressure data will be presented in the form of contour plots that show lines of constant pressure coefficient on the model undersurface. Nozzle-thrust calibrations and jet-flow-pressure survey information are also provided.

## Nomenclature

$A_{jet}$	sum of jet area for a given configuration, in. <sup>2</sup>
axial	balance axial force, lb
$c_p$	pressure coefficient, $\Delta p/q_{jet}$ , psi
d	individual jet diameter, in.

$D_e$	equivalent jet diameter based on total jet area, in.
e	half the distance between adjacent jets, in.
h	model height above ground plane, in.
$\Delta L$	jet-induced lift, lb
$N_1$	balance normal force number 1, lb
$N_2$	balance normal force number 2, lb
p	pressure, psig
$P_{amb}$	ambient pressure, psia
$P_{ref}$	reference pressure, psig
$P_t$	local total pressure, psia unless noted
$P_{t,n}$	total pressure of the nozzle, psia
$P_t/P_{amb}$	nozzle pressure ratio
$P_{t,z}$	total pressure at distance Z, psia
$\Delta p$	pressure difference, psi
$\Delta PM, \Delta M$	jet-induced pitching moment, in.-lb
$q_{jet}$	jet dynamic pressure, $q_{jet} = T/(2 * A_{jet})$ , psi
$q_n$	jet dynamic pressure at the nozzle exit, psi
$q_z$	jet dynamic pressure at distance Z, psi
T	total jet thrust for a given configuration, lb
$V_\infty$	freestream velocity, ft/sec
X	longitudinal position on the planform with X = 0 halfway between the nozzle set, in.
$X_n$	longitudinal distance from the nozzle center, in.
$Y_n$	lateral distance from the nozzle center, in.
Y	lateral position on the planform with Y = 0 along planform plane of symmetry, in.
Z	distance downstream of the nozzle exit, in.

\*KSA Technology, Columbus, Ohio.

## Introduction

A test program to expand the data base on jet-induced forces for short takeoff and vertical landing (STOVL) aircraft both in and out of ground effect has been completed. The test program addresses multi-jet suckdown, fountain effects, ground vortex effects of a single circular or rectangular jet, and twin rectangular thrust reverser effects. Hover tests performed at NASA Ames Research Center from January 25, 1991, to March 8, 1991, are reported. In addition to force balance instrumentation, all test models contained pressure instrumentation on the undersurface. Forward-speed data from NASA Langley Research Center for similar configurations are reported in reference 1.

Data from these tests add significantly to the current jet-induced force data base for STOVL configurations. Further development of empirical prediction methods for jet-induced forces, to provide more configuration diversity and improved overall accuracy, depends on the viability of this STOVL data base. In addition, computational fluid dynamics (CFD) codes can be validated using this data base.

The available data and the shortfalls of the existing data base (for hover) are briefly addressed. A detailed discussion of the limitations of current prediction methodology for jet-induced forces is provided in reference 2. The JCAHT facility, the models used in the hover tests, and the instrumentation used with these models are described. Finally, the test data are presented, including nozzle calibrations, along with a short discussion on some of the data. A sketch of each configuration tested and the tabulation of the data are included in the appendix.

## Background

Accurate predictions of the aerodynamic characteristics for advanced STOVL aircraft in close proximity to the ground are highly desirable. The jet-induced forces generated on these aircraft can have a significant effect on aircraft performance, especially when calculating thrust and control requirements for operations close to the ground. Thus, the ability to accurately estimate the jet-induced ground effects of vertical/short takeoff and landing (V/STOL) aircraft becomes an important part of the design procedure and cannot be overlooked. Several empirical estimating procedures for jet-induced ground effects are available for the hover and short takeoff and landing (STOL) portions of the flight regime, but are limited in accuracy (ref. 2).

The existing STOVL-configuration data base for jet-induced forces is insufficient to enable the development

of a methodology to adequately predict the aerodynamics characteristics of configurations which are of current interest. This includes configurations with high disk loading (nozzle pressure ratios (NPRs) greater than 2), large planform-to-jet area ratios (greater than 100), nonsymmetric thrust and jet patterns, and widely differing undersurface geometries.

The ground effects induced by jet flows impinging on the ground are dependent on many aircraft parameters. The complete aircraft configuration (jet shape, location, angle, and number, along with the shape of the aircraft planform and undersurface) is an important factor in the magnitude of the ground effects encountered.

The relative positioning and the number of the jets are strong factors in determining jet-induced effects. Multi-jet configurations can experience large lift losses (suckdown) and large fountain effects during hover. Figure 1(a) shows the different flow regions around an aircraft in hover. Figure 1(b) shows the flow regions during forward flight or crosswind hover close to the ground. In this situation a "ground vortex" is formed by the collision of the jet flow along the ground with the free-stream air. This vortex can significantly alter the suckdown forces by further changing the flow field around the aircraft. Existing isolated jet investigations of the ground vortex have shown that the test conditions can affect the vortex size and shape. It appears that the ground boundary associated with testing in a wind tunnel is one significant parameter in predicting the effects of the ground vortex (ref. 3).

The current empirical prediction methods for the jet-induced aerodynamic characteristics of STOVL configurations require the summation of several parameters. The overall accuracy is limited to that of each individual parameter. Table 1 presents the individual increments of the current prediction methods for STOVL- or V/STOL-aircraft lift during hover and an assessment of the prediction accuracy for each increment.

**Table 1. Accuracy of current prediction methods**

Increment	Accuracy of method
1. Base loss out-of-ground effect	Adequate
2. Equivalent single-jet suckdown	Under estimated
3. Fountain lift	Over estimated
4. Additional multi-jet suckdown	Over estimated

The existing methodology can reasonably predict the sum value of these four items for limited configurations. The over estimation of the fountain lift (item 3) and the additional multi-jet suckdown (item 4) tend to cancel, giving a



correct total jet-induced lift-increment. However, most new configurations are outside of the existing data base, and the sum of over estimation of the fountain and multi-jet terms (items 3 and 4) provides poor results.

Also, the prediction methods do not provide an estimate of pitching moments induced in hover for configurations that are not symmetrical fore and aft. Since most configurations are not symmetrical fore and aft, no empirical prediction methods exist for pitching moments during hover. Better prediction or measurement of the parameters is required to use the methodology for more diverse configurations. Obtaining pressure data on and around the model will improve the current prediction methods.

A more detailed discussion of the limitations of the current jet-induced effects prediction methodology is provided in reference 2.

## Facility Description

### General

The NASA Ames Jet Calibration and Hover Test (JCAHT) facility is shown in figure 2 (ref. 4). This facility provides jet-induced effects data on STOVL configurations both in and out of ground effect during hover in still air. The facility consists of a hover test rig (HTR), a jet calibration rig (JCR), and a jet-wake survey rig. Two high-pressure supply lines can be independently controlled, providing up to 300 psig air at either the JCR or the HTR.

The JCAHT facility was used to calibrate each of the nozzles used at the Ames and Langley test facilities, and to obtain extensive hover characteristics for a series of nozzle arrangements and flat-plate planforms.

### Hover Test Rig

The hover test rig (HTR) is the heart of the JCAHT facility. It is used to measure the jet-induced forces on a STOVL model hovering in and out of ground effect. A picture of the delta-wing model attached to the HTR is shown in figure 3. The forces on the model are measured by a six-component strain-gage balance that is supported from the structure of the rig and is located between the nozzle plenum assemblies. The plenums and associated nozzles are attached directly to the rig, but do not make contact with the model (i.e., the nozzles are nonmetric). By attaching only the model to the balance, the jet-induced forces imposed on the model can be directly measured. Gaps between the model and nozzles are kept

as small as possible (nominally 0.05 in.) to minimize or eliminate errors from flow entrainment through the gap.

In order to simulate different heights above the ground, a ground plane is moved to different heights relative to the model by a remote-control hydraulic lift fixed to the rig. For the tests described in this report, the ground plane was 8 ft × 8 ft (fig. 4) and was centered underneath the model.

To get the test data in a nondimensional form to compare with other model configurations and sizes, the thrust, flow angles, and velocity profiles of the jets installed on the HTR must be known. The JCR is used for this purpose.

### Jet Calibration Rig

The jet calibration rig (JCR) is used to calibrate thrust (jet force) that is not measured on the HTR and is used for correlation with a reference pressure that can be measured on the HTR. The JCR measures thrust forces produced by a jet flow and is shown in figure 5(a). High-pressure air enters the rig from the left, and is split into two flows that travel through a set of balance isolation coils designed to minimize pressure effects on the balance. The two air-flows are brought back together at an outlet plenum that sits directly over the balance on the right side of the rig. The plenum and nozzle arrangements to be tested are bolted in an inverted position (jet flow pointed up) directly to the outlet plenum. Both the thrust magnitude and the thrust angle of the jet can be determined from the balance readings. A total-pressure probe is available for measuring the pressure distribution at the exit plane of the nozzle. This total pressure is used to calculate NPR (an important parameter in correlating jet-induced effects) and to correlate with a nozzle reference pressure located within the nozzle-plenum assembly. The correlation between total and reference pressure is used while operating the nozzle on the HTR to provide thrust and NPR information.

### Jet-Wake Survey Rig

The jet-wake survey rig is a three-axis traverse mechanism. Located next to the JCR, it positions a Pitot survey probe (fig. 5(a)). The Pitot probe measures the total pressure in the nozzle flow (fig. 5(b, c)). The Pitot probe can be moved on all three axes to provide nozzle exit-flow survey traces parallel to or perpendicular to the nozzle exit plane.

## Model Description

The parametric flat-plate model tested on the HTR had modular panels (with and without pressure taps). There

were a variety of nozzles that could be placed at different locations in and around the model. Details about the planform panels, the nozzles, and the model instrumentation follow.

### Planform Panels

The planform panels tested on the HTR included a delta wing and several rectangular shapes. The planform shape, nozzle spacing, number of nozzles, and NPR were varied to produce 31 different configurations. The planforms were designed to be modular so pieces could be interchanged to provide many different configurations with minimal hardware. In addition to the pressure-instrumented delta wing (fig. 6(a)), there were 17 different rectangular plates labeled P1–P17. Figure 6(b) shows some of these plates; note the circular and rectangular nozzle cutouts. Plates P1–P13 were instrumented with pressure taps, while plates P14–P17 were not. Pressure-tap numbers were uniquely assigned starting with the delta wing and ending with plate P13. This provided pressure tap numbers ranging from 1 to 242. Although numbered, ports 92 and 158 were not installed in the model and do not appear in the data or configuration files. A summary of the 31 configurations tested is provided in figure 7(a–c). The appendix contains a 1:4 sketch of each configuration tested and the data obtained.

Each configuration has an associated code name that describes the planform and nozzle parameters. The configuration code is made up of four parts separated by an underline character:

4C\_8\_2.5/3.9\_12/8

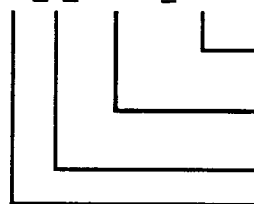

- (4) planform length/width  
DW = delta wing
- (3) lateral jet spacing  
forward jet/aft jet
- (2) longitudinal jet spacing
- (1) number & type of nozzles  
C = circular  
R = rectangular

This configuration code refers to a configuration with four circular jets. The longitudinal (forward to aft) jet spacing is 8 in. The forward-jet lateral spacing is 2.5 in. and the aft-jet lateral spacing is 3.9 in. The planform is 12 in. long and 8 in. wide. Two other examples of configuration code names are:

2C\_12\_0\_DW  
3C\_16\_2.5\_20/8

The first example refers to a model with two circular jets with a 12 in. spacing. Side-by-side jet spacing is zero; therefore, the jets are along the model centerline. The planform is the delta wing. The second example has three circular jets with a forward to aft jet spacing of 16 in. The two forward jets are laterally spaced 2.5 in. apart and the remaining aft jet is located along the centerline. The planform is 20 in. long and 8 in. wide.

Nominally, half of each planform was instrumented with pressure taps (fig. 8) since the planforms and nozzle arrangements were symmetrical about the body longitudinal centerline. Exceptions were planforms with 2.5 in. and 3.9 in. side-by-side nozzles where pressure taps were located laterally along the centerline passing through the two nozzles (fig. 9). Flow patterns between the nozzles at low heights were anticipated to be, and sometimes found to be, nonsymmetrical. Detailed pressure-tap locations are provided in appendix A after the model sketch for each configuration tested. Although there were 31 planform and nozzle arrangements, there were actually 32 different pressure-field configurations tested. Configuration 2C\_16\_0\_12/24 had two different pressure-tap layouts. To provide more data on the fountain decay on the aircraft undersurface, plates P2 and P11 were switched. This second configuration was designated with an “X” at the end of the code name (2C\_16\_0\_12/24X).

With the exception of the delta-wing planform, the modular planform pieces were held together with a frame made from aluminum 90 deg angle stock. The L-shaped corner of the aluminum angle stock was kept toward the inside of the frame structure to keep the model edge as thin as possible; unpublished data indicate that the edge contour can affect the jet-induced characteristics.

### Nozzles

There were six nozzles calibrated on the Ames JCR. Each nozzle had a “type” designation of 1–6. Table 2 provides a short description of each nozzle type. Table 3 summarizes nozzle geometry and the configurations with which they were used.

**Table 2. Description of the nozzle types used**

Nozzle type	Description
1	Forward circular nozzle
2	Aft circular nozzle
3	Twin 3.9 in. center-to-center nozzles
4	Twin 2.5 in. center-to-center nozzles
5	Aft rectangular nozzle
6	Forward rectangular nozzle

**Table 3. Summary of nozzle information**

Nozzle type	Diameter or length/width	Area (in. <sup>2</sup> )	Used on configuration
1	1.2 in.	1.13	All 2C_[8,12,16]... All 3C...3.9...
2	1.2 in.	1.13	All 2C_[8,12,16]... All 3C...2.5...
3 (3.9 in. spacing)	0.87 in. each $D_e = 1.22$ in.	1.16 total	2C_0_3.9_12/8 3C_8_3.9_12/8 3C_12_3.9_16/8 3C_16_3.9_20/8 All 4C...
4 (2.5 in. spacing)	0.85 in. each $D_e = 1.20$ in.	1.13 total	2C_0_2.5_12/8 3C_8_2.5_DW 3C_8_2.5_12/8 3C_12_2.5_DW 3C_12_2.5_16/8 3C_16_2.5_20/8 All 4C...
5, 6	0.613 in. × 1.840 in. $D_e = 1.20$ in.	1.13	All 2R...

Because the models for both the Ames HTR and the Langley wind tunnel were nonmetric with the nozzles, the nozzles had to be calibrated for thrust. This calibration (performed with the JCR) provided the necessary thrust and nozzle-pressure calibrations so that the correct nozzle conditions could be set and monitored when run on the HTR or at the Langley wind tunnel. A more detailed discussion of each nozzle type is presented under “Nozzle Calibrations/Surveys” in the “Jet Calibrations” section.

The NPR is defined as the nozzle total pressure divided by room (ambient) total pressure, and is the primary flow parameter used in empirical jet-induced prediction techniques. An NPR of 1.0 means no air is flowing through the nozzle.

Total-pressure surveys were obtained at the nozzle exit planes in order to calculate the actual NPR. The surveys were used to document the jet-exit velocity profile, and can be used to indicate how well the nozzles are performing. Exit profiles are shown under “Nozzle Calibrations/Surveys” in the “Jet Calibrations” section.

### Instrumentation

Measurements during model testing on the HTR consisted of room (ambient) pressure and temperature, model surface pressures, and nozzle reference pressures. Model surface pressures from all plates to be tested were plumbed to four mechanical scanivalve connectors.

The instrumentation used during this test consisted of two six-component strain-gage balances, a scanivalve module consisting of four 48-port scanivalves, various pressure transducers for measuring nozzle, plenum, and ambient pressures, and one thermocouple for measuring ambient temperature.

The balance is used to measure model jet-induced aerodynamic forces while on the HTR or the nozzle thrust while on the JCR. Since the balance is comprised of six different gages, a load on any single gage will also produce some output (usually small) on the other gages; these are referred to as “gage interactions.” These interactions are taken into account by the data acquisition system as part of the balance calibration data. The balance used on the JCR during this test was a 1.5-in.-diameter strain-gage balance. The balance gage capacities are 300 lb on the axial gage, 500 lb on the normal force gages (N1 and N2), 250 lb on the side force gages (S1 and S2), and 60 ft/lb on the rolling-moment gage. A similar balance was used for the HTR with the only difference being a 100 lb limit on the axial gage. During data acquisition on the HTR, the scanivalves were stepped through all 48 ports at each height. Each height was considered one run point. The rate of acquisition was approximately 1 port/second.

A 25 psia pressure transducer and a thermocouple were used to measure the room (ambient) pressure and temperature during testing.

## Jet Calibrations

Data from the JCR calibration were used when calibrating the nozzles. Calibrations from the nozzles were in turn used when testing the model on the HTR. The “Calibration of the Jet Calibration Rig” section will explain how the calibration was done and provide the corresponding results. The “Nozzle Calibrations/Surveys” section will present pressure and thrust data along with pressure surveys of the nozzle flow. The final section, “Comparison of Jet Decay Rates,” compares the jet decay rates between the current nozzle sets and selected studies.

### Calibration of the Jet Calibration Rig

The JCR is designed to minimize forces on the balance due to the high pressure air lines so that only the forces from the jet (or thrust system) are obtained. The high-pressure air lines induce a force on the balance which must be calibrated out so that only the jet forces are obtained. Each of the six nozzle sets calibrated on the JCR were mounted so that their thrust was directly in line with the balance axial gage. The six-component strain-gage balance was mounted on the JCR with the axial gage perpendicular to the floor.

The calibration of the JCR consisted of determining the effect of the rig components on the balance. Pressurizing the coils (when running) may produce a small force in the balance normal direction and possibly a small amount in the axial direction (trying to unwind the coils). Since the coil system is symmetrical, no forces should be seen on the balance side force or rolling moment gages as the coils are pressurized. This hypothesis was confirmed by the calibration data.

The first step in calibrating the JCR was to load only the axial gage to determine the measured versus applied load curves (fig. 10) for the axial gage with and without pressure in the coils. Figure 10 shows no effect of pressure but a +2 percent shift in the calibration slope. This discrepancy was accounted for in the thrust calculations.

Figure 11 shows the effect of coil pressure (166 psig maximum) on the N1 and N2 normal-force gages and the axial gage. The axial gage shows negligible effects from a coil pressure of 166 psig. However, the normal-force gages show a linear effect with pressure. Figure 12 shows the effect of combining coil pressure with normal loading on the normal and axial-force gages. Data plotted in figure 12(a, b) are for both the loading and the unloading of the N1 gage (applied normal load) in the normal-force gage direction. Figure 12(c) shows the effect on the axial gage from both coil pressure and normal loading. The axial gage is unaffected by coil pressure, but is slightly

affected by a normal load. Slopes and offsets from these plots were used to determine the corrections to the balance output in computing actual nozzle thrust.

### Nozzle Calibrations/Surveys

Nozzle calibrations and surveys used in the investigations were conducted in the JCAHT facility on the JCR. There were six nozzle arrangements calibrated (refer to tables 2 and 3 for a summary of nozzle descriptions, geometries, and usage).

The JCR with nozzle-type 1 installed is shown in figure 5(b). Most of the nozzles were designed to be used in the Langley wind tunnel model, which uses the same delta-wing planform as the Ames model but contains an upper surface shell. Because the plenum and nozzles had to fit within this shell, the nozzles had to be fairly short. In an attempt to improve flow quality in these short nozzles, a perforated flow-distribution plate was installed a small distance upstream from the nozzle exit. These nozzles also used an adapter for installation on the HTR. For the nozzle calibrations and surveys, the same nozzle, adapter, and plenum assembly were mounted on the JCR as shown in figure 5(b).

Surveys of the jet-exit flow were made using a Pitot probe mounted on the jet-wake survey rig (fig. 5(a, b)). A continuous trace of the Pitot pressure reading was plotted as a function of traverse position on an analog x-y plotter. The general procedure for flow surveys consisted of taking surveys across the jet at the exit plane. These surveys were then used to assess the flow quality and determine if alterations to the perforated plates were required. If alterations were required, another flow survey was done to determine the flow quality and document the changes. A vertical traverse (z axis) was taken to document the decay of the jet core flow as a function of the distance from the nozzle exit. Additional pressure surveys were taken across the jet flow at various distances downstream from the nozzle exit.

To calibrate for nozzle thrust, the measured thrust (from the JCR balance corrected for rig interactions) was plotted against NPR. Nozzle total pressure was measured with a total-pressure probe at the nozzle exit. Then the NPR was plotted against nozzle reference pressure. These calibrations were needed to calculate thrust because only the nozzle reference pressures were measured when mounted on the HTR.

Thrust calibrations from the JCR appeared to be linear from NPRs of 1.5–6.23. The calibrations were expected to be linear for NPRs greater than 1.89 since the nozzle was choked and should respond linearly with a change in pressure. The small nonlinearity present from an NPR of 1.5

to 1.89 was within the data scatter of the calibration and was not accounted for.

Each of the nozzles tested had a single porous plate at the inlet of the nozzle with the exception of nozzle-type 3 (twin jets, 3.9 in. spacing) which had three sets of porous plates to help provide a good exit-pressure distribution.

**Nozzle-types 1 and 2**— These 1.2-in.-diameter circular nozzles were the baseline nozzles used in the investigations and one is shown attached to the JCR in figure 5(b). The nozzles were used separately in either the forward (nozzle-type 1) position or the aft (nozzle-type 2) position. Figure 13 shows a sketch of a 1.2-in.-diameter nozzle, including the nozzle adapter and the perforated-plate location. A pressure tap was installed about 0.1 in. upstream from the nozzle contraction to provide a reference pressure for thrust calibrations. The nozzles have a modified American Society of Mechanical Engineers (ASME) nozzle-exit contour as shown in figure 14. The thrust and NPR calibrations for the front and aft circular nozzles (types 1 and 2) are presented in figure 15 and show excellent agreement. These nozzles were also used in the model tested in the Langley wind tunnel.

A pressure survey at the nozzle exit for nozzle types 1 and 2) is shown in figure 16 for various NPRs. Because of the short distance available to develop the jet flow (from the plenum exit to the perforated plate in the nozzle), it was not possible to obtain a uniform or “top hat” total-pressure distribution at the nozzle exit. However, the jet decay curves (fig. 17) show a potential core up to about 5 or 6 jet diameters at subcritical pressure ratios, thus generally indicating a good-quality jet. At supercritical pressure ratios (NPR = 4 and 6) the shock cell structure is apparent in the decay curves. The large drop in total pressure immediately downstream from the exit and subsequent oscillations are due to the pressure losses in the plume-expansion region and across the normal shock that existed in front of the Pitot probe.

**Nozzle-type 3**— These 0.87 in. diameter nozzles were available from a previous study and were used only on the hover part of this study. These nozzles were used as a pair and were attached to a plenum cover plate so that the center-to-center (side-by-side) spacing of the nozzle exits were 3.9 in. (fig. 18). These nozzles conform to the ASME long-radius nozzle definition (fig. 19). Because these nozzles had a relatively long flow-development section and the distance from the plenum to the exit was relatively long (14.4 individual jet diameters), the nozzles were used without flow distribution plates. In contrast to the shorter nozzles (types 1 and 2), the exit pressure profiles for these nozzles were very uniform. The pressure in the plenum, feeding the nozzle pair, was used as the reference pressure for thrust and NPR calculations.

The thrust and NPR calibrations are shown in figure 20. Thrust was calibrated for the pair since there was no way to measure the thrust of the left and right nozzles separately. Separate flow (pressure) surveys were made for each nozzle and show excellent agreement (fig. 21). This indicates good flow distribution between the two nozzles. The flow surveys made at various distances downstream from the jet exit (fig. 22(a, b)) show that the jets are far enough apart that their flows do not begin to merge until about 15 diameters from the exit. The apparent loss in total pressure in the middle of the jet at a height of 5 in. ( $z/d = 5.8$ ) and a NPR = 6.2 (fig. 22(b)) is due to the total-pressure loss behind the normal shock that forms in front of the Pitot tube in the supersonic flow.

**Nozzle-type 4**— These nozzles, with an exit diameter of 0.85 in. (fig. 23), were attached as a pair to a plenum plate so that the center-to-center (side-by-side) spacing of the nozzle exits was 2.52 in. They also had a modified ASME nozzle contour (fig. 24). The plenum to which these nozzles were attached was relatively small with a wire mesh inside to help provide a more uniform flow into the nozzles. The reference pressure tap was located in the plenum. The thrust and NPR calibrations are shown in figure 25. Again, as with the 3.9-in.-spaced nozzles, the thrust calibration was done for the pair. Separate flow surveys were done for each of the nozzles at the exit plane (fig. 26) with the pressures measured on the centerlines showing excellent agreement. The flow surveys made at various distances downstream from the exit (fig. 27(a, b)) indicate that merging of the nozzle flow begins at 6–10 diameters downstream. As with the 3.9-in.-spacing jets, the apparent pressure loss in the center of the flow for the NPR = 6.2 case (fig. 27(b)) is due to the total-pressure loss behind the normal shock that forms in front of the Pitot probe.

The jet-decay curves (fig. 28) show a potential core of 5–6 nozzle diameters at subcritical pressure ratios, thus indicating good quality flow. At supercritical pressure ratios (NPR = 4 and 6), the shock cell structure is apparent in the jet-decay curves. The large drop in total pressure immediately downstream from the exit and the subsequent oscillations are due to the pressure loss across the normal shock located in front of the Pitot probe.

These nozzles were also used in the model at the Langley wind tunnel.

**Nozzle-types 5 and 6**— These rectangular nozzles are shown in figure 29. Each nozzle had the same exit dimensions of 0.613 in.  $\times$  1.840 in. with a contoured wall section along the long edge and a flat wall section along the short edge leading to the exit plane. The contoured nozzle section is shown in figure 30. A porous plate was located at the entrance of the nozzle. The thrust and NPR

calibration curves (fig. 31) show that the aft nozzle (type 5) had a slightly lower thrust than the forward nozzle (type 6). These thrust differences were taken into account when setting and computing the thrust and NPR of the front and aft nozzles during model testing. The porous plates at the nozzle entrance were modified to increase the flow at the narrow ends. The exit pressure distributions (figs. 32 and 33) show lower flow at the narrow ends of the rectangular nozzles. These were the best profiles attainable without redesign. Although the flow distribution at the nozzle exit plane may not have been ideal, the surveys at various distances downstream from the exit (fig. 34(a-d)) and the decay curves (fig. 35) indicated relatively good quality flow.

The type 5 and 6 nozzles were also used in the model at the Langley wind tunnel.

### Comparison of Jet Decay Rates

A jet issuing into still air mixes with the surrounding air and decays as shown by the data in figures 17, 28, and 35. Kucheman and Weber (ref. 5) have shown that close to the exit the mixing does not penetrate to the centerline, thus leaving a full velocity core (potential core) for a distance of about six nozzle-exit diameters for subsonic jets. Beyond this point, the mixing causes the velocity on the center axis to decrease in direct proportion to the distance. The dynamic pressure sensed by the Pitot probe will therefore be inversely proportional to the square of the distance from the exit plane.

The decay curves for the jets from the four nozzle sets of the present investigation have been replotted using a log-log scale and are shown in figure 36(a)(c-e). Similar data for a 1.23 in. diameter nozzle from a previous test are also included (fig. 36(b)). As expected, beyond the end of the potential core the ratio of the total pressure measured by the Pitot probe to that of the nozzle is inversely proportional to the square of the distance from the exit.

This decay relationship should be true at all NPRs. However at NPRs above 1.89, where supersonic flow is generated, the total pressure loss behind the normal shock that forms in front of the Pitot probe indicates lower pressures than are actually present. At these conditions, the inverse square relationship can only be seen at greater distances from the nozzle exit where the flow has become subsonic. At these higher NPRs, the decay curves are shifted to the right indicating that the "effective" potential-core length increases with NPR.

The decay curves for a J-85 jet engine with several nozzle configurations were measured in reference 6 and have been replotted in figure 37(a-c). Again, as with small cold-air jets (fig. 36(a-e)) the jet dynamic pressure decays

with the square of the distance from the nozzle exit, and the potential-core length increases with nozzle pressure ratio. The exception to the inverse square relationship occurs with the four-nozzle configuration. Beyond a distance of seven effective diameters (14 individual jet diameters) the decay rate decreases (probably because the closely spaced jets are beginning to merge into a single jet).

The effective-core lengths for the various nozzles are compared in figure 38(a, b). The effective-core lengths for the J-85 engine powered nozzles (at a given NPR) are less than for the small cold-air driven jets probably because of the greater distortion of the exit dynamic-pressure distribution (top of fig. 38(a)). The short-nozzle J-85 configuration exhibits a large drop in pressure at the center because of the wake of the turbine disk fairing in the flow. If the decay curves were nondimensionalized by an area-weighted average of the exit dynamic-pressure distribution, the core lengths would probably be much closer.

The effective-core lengths of all of the circular nozzles increase with the 1/4 power of the NPR. However, the effective-core length of the rectangular nozzle increases with the 1/6 power. These power laws appear to fit at both subcritical and supercritical NPRs.

### Model Test Results

All the model test data are presented in the appendix. Since all test runs were done with cold, dry high-pressure air flowing through the nozzles, temperatures at the nozzle exits were often below freezing (32 °F). When running for a prolonged period of time, ice formed on the outside of the nozzles. In some cases this ice actually closed the gap between the nozzles and the model. Balance data for run points where this occurred are not presented. The nozzles and model were frequently de-iced and the gap clearances were carefully watched. However, there could be a few run points where the balance data was biased due to ice bridging the gap. Any large discrepancies found between the integration of the pressure data and the balance data (presented at the end of each data listing in the appendix), especially the pitching-moment data, might be due to unnoticed icing problems.

It should also be noted that the resolution of the pitching moment is about five times coarser than the lift measurements. Pitching moment is determined by the two 500 lb normal-force gages, as opposed to the 100 lb axial (lift) gage. Unfortunately, many of the test conditions produced small pitching moments that could not be measured as accurately as the lift forces.

Model test results on the effects of three parameters are briefly discussed here. These parameters are: jet spacing (8, 12, 16, 2.5, and 3.9 in.), planform size, and NPR. Both balance and pressure data are used in discussing these parameters. Most of the pressure data are presented using contour plots that show lines of constant pressure coefficient on the model undersurface. The pressure coefficient used is defined as  $\Delta p/q_{jet}$ , where  $q_{jet}$  is the calculated incompressible-jet dynamic pressure given by  $q_{jet} = T/(2 * A_{jet})$ .

In each of the contour plots, the solid contour lines indicate positive pressures and the dotted lines represent negative pressures. Nominally, the difference between contour lines was 1, or  $c_p = 0.001$ , since the data were multiplied by 1000 before plotting. In some cases, the difference between contour lines was increased to make the plot more readable. The  $c_p$  contours were generated over the entire model undersurface by reflecting the pressure information about the longitudinal axis of the planform. For configurations in which the pressure taps crossed the model symmetry, pressure information was used directly (the pressure-tap counterparts from the other side of the planform were not reflected).

As a result of a limitation in the plotting process, some of the contour plots show contour lines extending slightly outside the model planform. In order to generate the contour plots, the pressure data had to be in a rectangular, or "regular," grid format. Because the pressure taps were not laid out in a regular pattern, a representative regular pattern had to be generated. The values of the regular grid points were determined by a weighted interpolation scheme stated by

$$Z_{jk} = \frac{\sum_{i=1}^n \frac{1}{D_i^w} Z_i}{\sum_{i=1}^n \frac{1}{D_i^w}}$$

where

$Z_{jk}$  is the value to be computed for node  $jk$  of the grid

$Z_i$  is value of an irregular point

$D_i$  is the distance from the node  $jk$  to the irregular point  $Z_i$

$w$  is the weighting factor (2.0 for this analysis)

$n$  is the number of irregular points that fall in the "search area" for the irregular points  $Z_i$ . In this analysis, the search area is two cells to the left,

two cells to the right, two cells above, and two cells below.

Since values for the regular grid points were determined based on data from the immediate area, some grid points just outside the planform were assigned values. Because the original data points did not normally lie on the regular grid points, the original data values were not usually preserved. This was especially true for large narrow peaks in some of the data. The actual maximum and minimum  $c_p$  values are therefore supplied with most of the contour plots. These values came directly from the data listed in the appendix.

### Jet Spacing

The effect of the relatively large forward to aft jet spacing was looked at only for the two-jet delta-wing configuration. These effects are shown in figure 39(a-c). Pressure data from the model's undersurface is plotted for the 8, 12, and 16 in. jet spacing at  $NPR = 2$  and  $h/D_e = 2.36$  ( $h = 4$  in.). These figures show that the fountain flow is intense, but relatively small at the close jet spacing, spread out, but smaller in magnitude at the intermediate 12 in. spacing, and actually quite large, both in area and magnitude, with the wider 16 in. spacing. Figure 40 shows the corresponding balance and integrated pressure data. This data shows an increase in suckdown for the 12 in. jet spacing, which can probably be attributed to the reduced fountain strength (fig. 39(b)). The cause for the large differences between the balance and pressure data at a jet spacing of 16 in. in figure 40(a) and at a jet spacing of 8 in. in figure 40(b) is unknown. The unsteady nature of the flow field and the slowness of the mechanical scanivalves may possibly be a cause for this difference as the pressure ports are scanned in sequence, taking about 1.5 min, as opposed to an instantaneous acquisition.

Also note in figure 39(a-c) the large negative pressures in between the jets and the fountain. These are generated by a vortex structure located in this same area and extends to the ground. As the jet spacing is reduced, the negative pressures tend to become more negative. This indicates an increase in the strength of the vortex structures. This trend tends to hold true until the jet spacing is reduced to a point where the vortex structure between the fountain and the jets seems to disappear.

The model surface pressures of the closer 2.5 and 3.9 in. jet spacing are shown in figure 41(a, b). Data from the configuration with a pair of 2.5 in. spaced jets at various heights at a NPR of 2.0 are shown in figure 41(a). Figure 41(b) shows data from a configuration with a pair of 3.9 in. spaced jets at the same test conditions. Although the maximum and minimum pressures are generally larger

at the lower heights for the configuration with 2.5 in. jet spacing, the fountain loses its effectiveness quicker than with the 3.9 in. spaced jets. Balance and pressure data (fig. 42) shows that the 2.5 in. jet spacing configuration has more suckdown than the 3.9 in. jet spacing configuration.

During testing, plots of the actual pressure data between the 2.5 in. spaced jets (fig. 43) showed that the flow was not always symmetrical as was the case for the 3.9 in. (fig. 41(b)) and wider spaced two-jet configurations. The same pressure distribution also shows that the usual vortex (wide negative-pressure regions) between the jets and the fountain does not exist with the 2.5 in. jet spacing configuration. Instead, there is almost exclusively a positive-pressure region spanning between the jets. From the contour plots of figure 41(a), it appears that the maximum pressures are skewed at an angle between the jets. It was thought that this skewing may have been caused by differences in nozzle thrust. Previously, the JCR showed excellent agreement between the nozzles (figs. 25–27). A total-pressure probe was mounted at the center of the jet exit for each nozzle, to make sure that the nozzle pressures (and thrusts) were symmetric. As can be seen in figure 44, the pressures of each nozzle are in almost perfect agreement. This may indicate that, in this case, the model flow structure was very sensitive to small changes in jet flow structure or model–ground geometry.

### Planform Size

The planform shape can also greatly affect the overall lift loss and pitching moments acting on an aircraft, especially close to the ground. Figure 45(a–h) compares the effects of planform shape between a small rectangular planform enclosing the nozzles and the delta-wing configuration. The fore/aft jet spacing is 8 in. Comparing the  $c_p$  contours between the planforms shows that the positive pressures in the fountain region are quite similar, except at the top height. However, the negative pressures on similar regions of the planforms are not similar and will equalize with a  $c_p$  approaching zero at the planform edges. The area in which negative pressures can act on figure 45(b) is much smaller than the area in which negative pressures can act on figure 45(a), where there is a more gradual equalization of  $c_p$  over the larger space from the jets to the planform edge. This larger area where the negative pressures can act tends to increase the overall configuration suckdown and results in a nose-up pitching moment at the lower heights (fig. 46). Also, the fountain pressures on the belly of the model tend to move forward at the edge of the planform (fig. 45(a–f)(h)). It is interesting to note that at the top height,  $h/D_e = 5.89$ , the fountain under the smaller rectangular planform (fig. 45(h)) is still

evident, while no fountain is evident under the delta-wing planform (fig. 45(g)).

Similar data are shown for the three-jet configuration in figure 47(a–j), but at a 12 in. fore/aft jet spacing. Figure 48 shows the corresponding balance and integrated pressure data. Data for this configuration were obtained at  $h/D_e$  as low as 1.18 ( $h = 2$  in.). At these low heights, the larger delta-wing planform had greatly reduced fountain pressures and increased negative pressures (also indicated by the plots of fig. 48 showing increased suckdown and pitching moments for the delta wing) compared to the rectangular planform (fig. 47(a, b)). Even though only the jet spacing was changed between this and the previous configuration (fig. 45), the  $c_p$  distribution is quite different. However, the resultant jet-induced loads are very similar as shown in figure 49, which shows the difference in balance data between the 8 and 12 in. jet spacing configurations. With the wider (12 in.) fore/aft jet spacing, the fountain on the model undersurface is skewed toward the front jets at the low heights and moves aft as height is increased. More specifically, the fountain center region moves aft as model height is increased, but the outer region of the fountain appears to stay in the same place. This may indicate that the fountain flow is not perpendicular to the ground plane, but at some angle that may or may not vary with height. This could be the case if the ground flow from the aft jet penetrates farther along the ground. Then, if the fountain flow between the two front jets penetrates farther aft (as distance from the ground is increased) it could “push” the center of the main fountain flow of the three-jet pattern aft, thus creating the “horseshoe” pattern at intermediate fountain heights as shown in figure 47(e–h)(j).

### Nozzle Pressure Ratio

Another parameter of the jet-induced characteristics is NPR. Figure 50(a–c) and 51(a–c) show the effect of NPR for two- and three-jet delta-wing configurations with the same 12 in. fore/aft jet spacing at  $h/D_e = 3.54$  ( $h = 6$  in.). It appears that the planform’s undersurface pressure-contour structures and magnitudes changed little with NPR. The same conclusion can be drawn from the nondimensionalized balance data shown in figure 52(a) for the jet-induced lift increment. However, the pitching moment seems to have a larger variation (and data scatter), especially at  $NPR = 6$ .

### Concluding Remarks

This report presented hover data obtained at the Ames JCAHT facility for a parametric flat-plate model. The model tested was a flat-plate design that allowed



variations in planform aspect ratio, number of jets, nozzle shape, and jet location. There were 31 different planform–nozzle configurations tested. Each configuration had numerous pressure taps installed to measure the pressures on the model undersurface. All pressure data, along with the balance jet-induced lift and pitching moment increments, are tabulated. For selected runs, pressure data was presented in the form of contour plots that show lines of constant pressure coefficient on the model undersurface. Nozzle thrust calibrations and jet-flow-pressure survey information were also provided.

As expected, jet spacing and layout had a significant effect on jet-induced lift loss and pitching moments. Unexpectedly, the 12 in. fore/aft spaced two-jet configuration had more suckdown than either the 8 in. or 16 in. spaced two-jet configuration. In addition, the very closely spaced (2.5 in.) two-jet configuration did not have the usual vortex (wide negative pressure regions) in between the jets and the fountain. At low heights, the 2.5 in. spaced jet configuration had a very skewed, nonsymmetrical high-pressure or fountain region between the jets. This may indicate that, in this case, the model flow structure was very sensitive to small changes in jet flow structure or model–ground geometry.

Comparing the  $c_p$  contours among the planforms for the 8 in., 12 in., and 16 in. fore/aft jet spacing shows that the positive pressures in the fountain region are quite similar, except at the top heights. However, the negative pressures on similar regions of the planforms are not similar and will equalize with a  $c_p$  approaching zero at the planform edges. For some of the three-jet configurations, a “horse-shoe” shaped fountain (high pressure region) was observed on the model undersurface.

It appears that the planform’s undersurface pressure-contour structure and magnitudes changed little with NPR.

Data presented in this report adds significantly to the current STOVL-configurations data base. Further development of empirical prediction methods for jet-induced forces to provide for more configuration diversity and improved overall accuracy, as well as the validation of CFD codes, depend on this data base.

## References

1. Kuhn, R. E.; and Stewart, V. R.: Effect of Forward Speed and Jet Arrangement on Jet Induced Suckdown and Fountain Effects. KSA 92-2, KSA Technology, Columbus, OH, Apr. 1992.
2. Stewart, V. R.; and Kuhn, R. E.: On the Prediction of Aerodynamic Characteristics of Powered Lift Fighter Configurations. KSA 89-1, KSA Technology, Columbus, OH, Jan. 1989.
3. Stewart, V. R.; and Kemmerly, G.: Characteristics of the Ground Vortex Formed by a Jet Moving Over a Fixed Ground Plane. AIAA Paper 89-0650, Jan. 1989.
4. Hange, C. E.; and Wardwell, D. A.: Small Scale Ground Effects and Hot Gas Ingestion Research. AIAA Paper 92-4252, AIAA Aircraft Design Systems Meeting, Hilton Head, SC, Aug. 1992.
5. Kucheman, D.; and Weber, J.: Aerodynamics of Propulsion. First edition, McGraw-Hill, New York, 1953.
6. McLemore, H. C.: Jet-Induced Lift Loss of Jet VTOL Configurations in Hovering Conditions. NASA TN-D-3435, 1966.

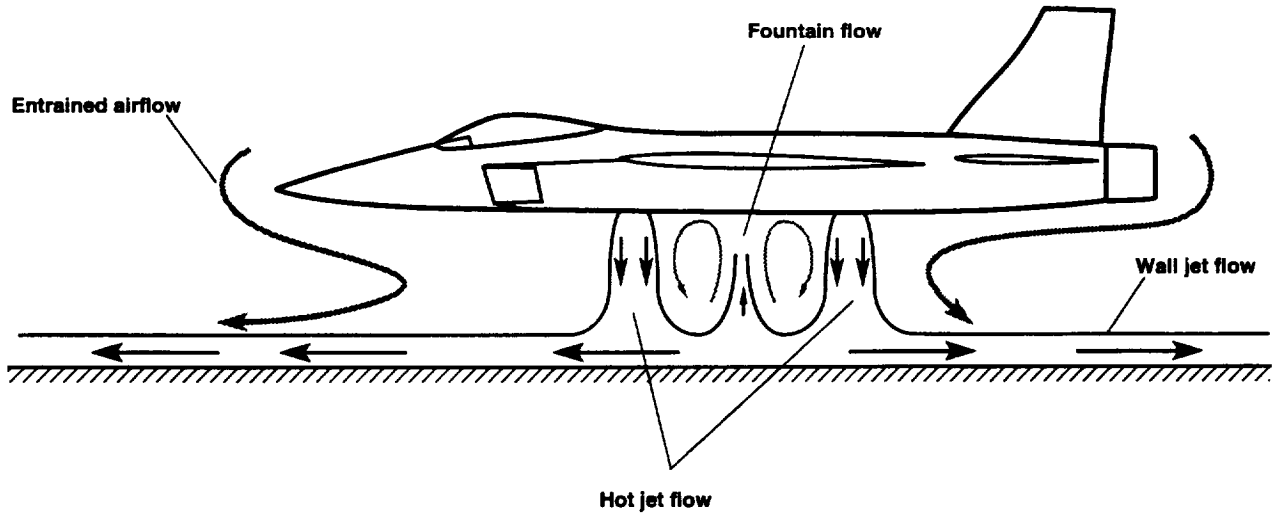

(a) During hover.

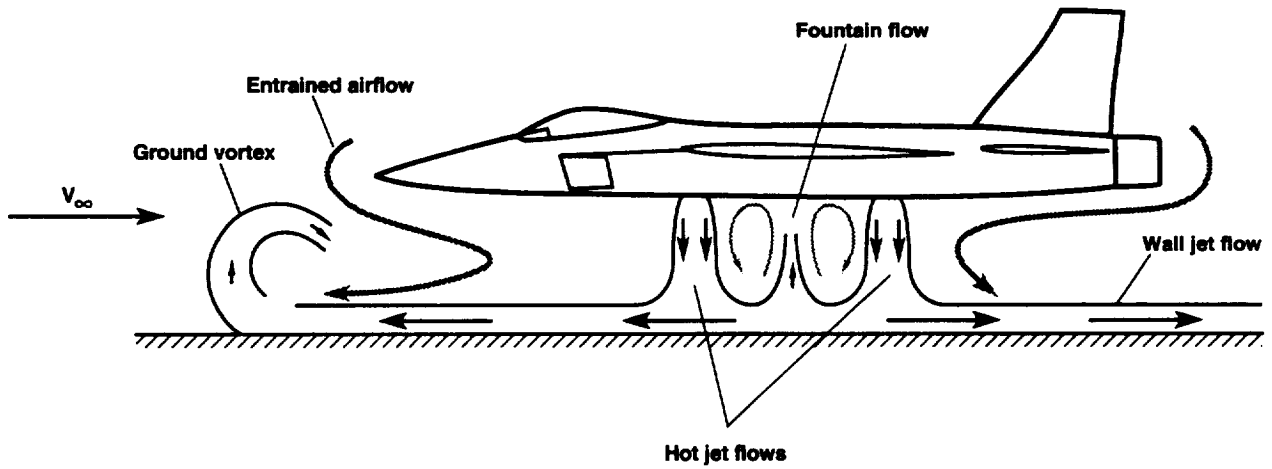

(b) At forward speed or with a headwind.

Figure 1. Flow structure around a short takeoff and vertical landing (STOVL) aircraft in ground effect.

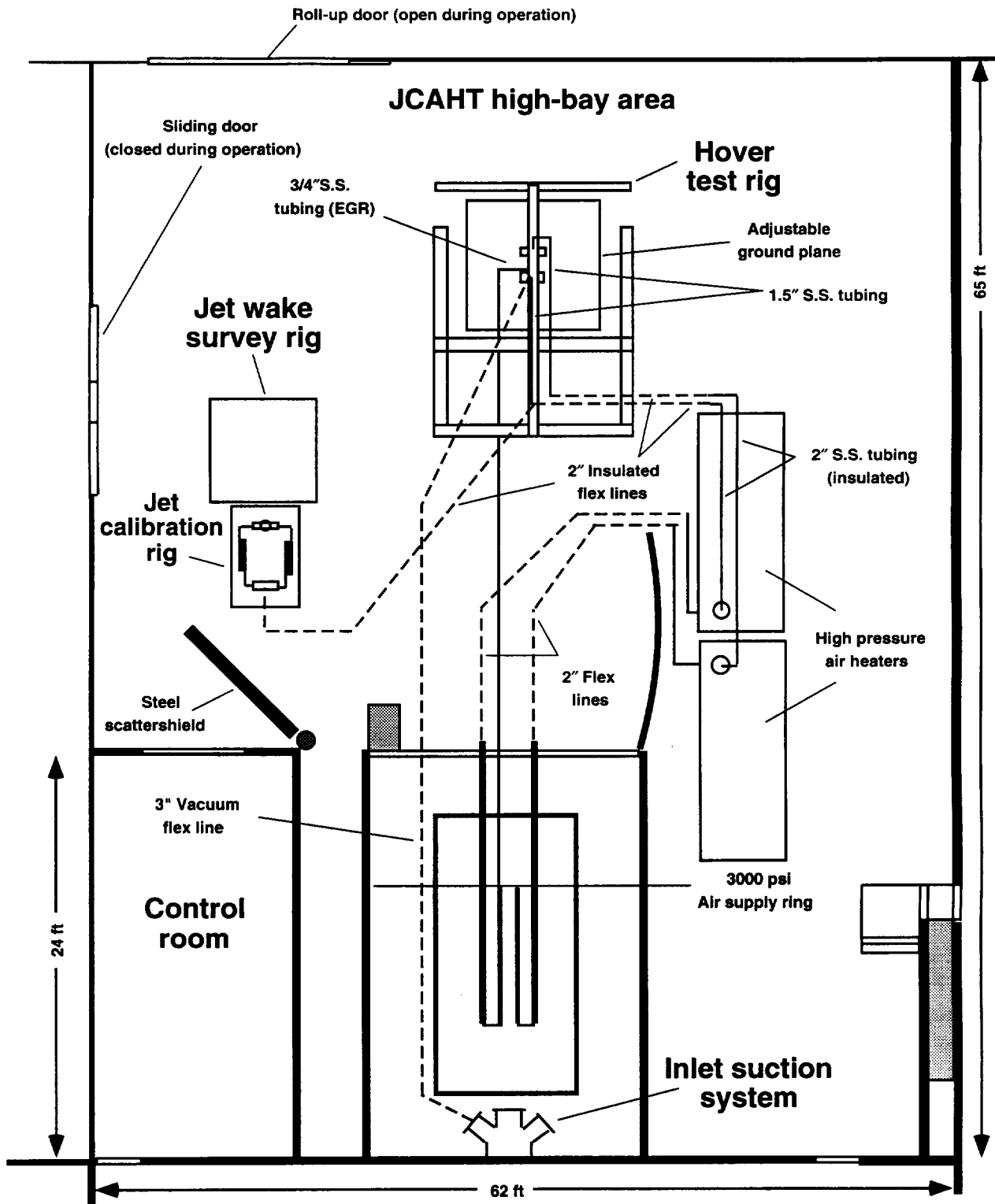
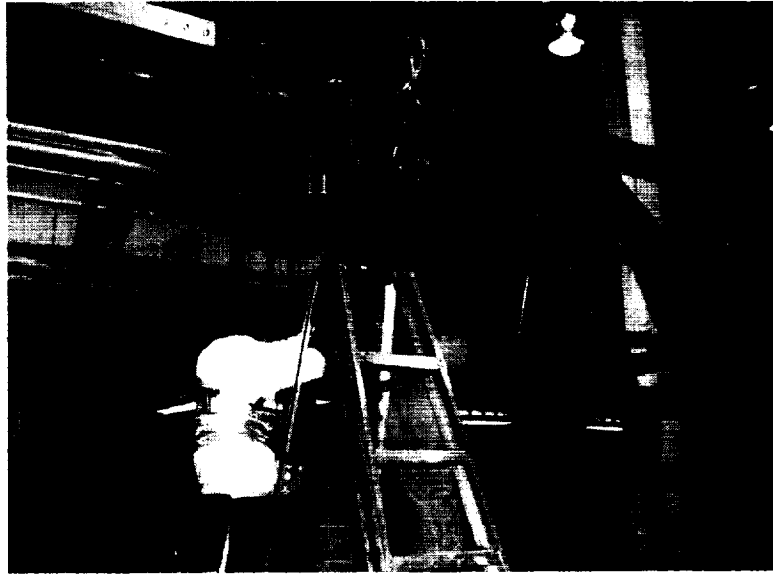

Figure 2. Layout of the Jet Calibration and Hover Test (JCAHT) facility.

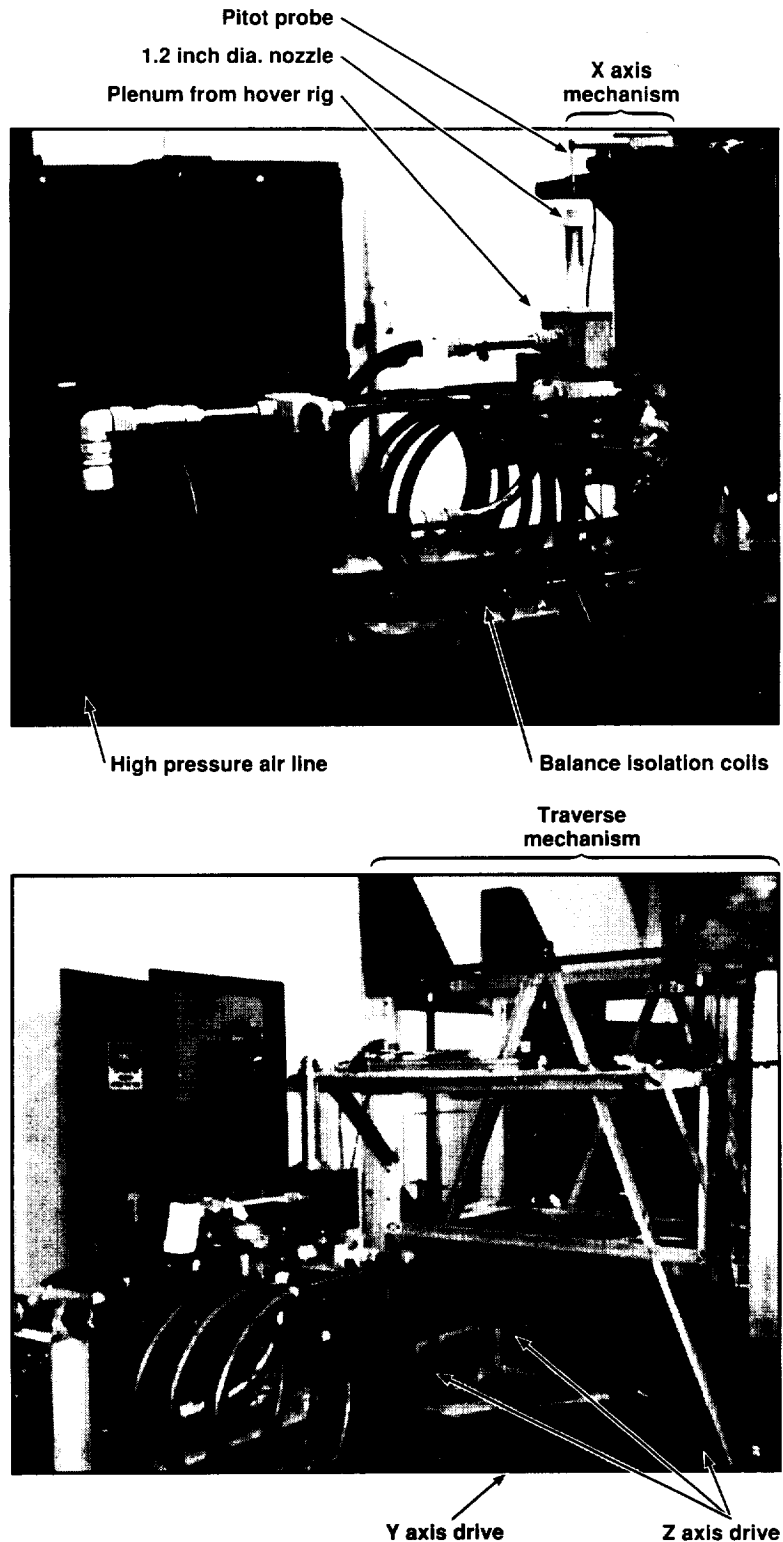

*Figure 3. The hover test rig (HTR) support with a delta-wing configuration attached.*



*Figure 4. Delta-wing configuration with the 8 ft x 8 ft ground plane in close proximity.*

ORIGINAL PAGE  
BLACK AND WHITE PHOTOGRAPH



(a) General arrangement.

Figure 5. Jet calibration rig (JCR) set used for thrust calibrations and jet flow surveys.

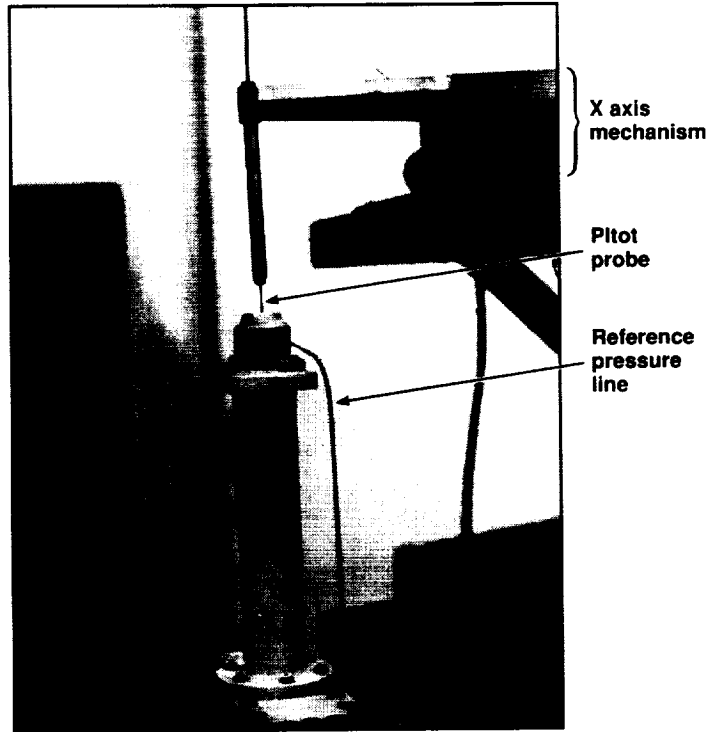

(b) 1.2-in-diameter circular nozzle.

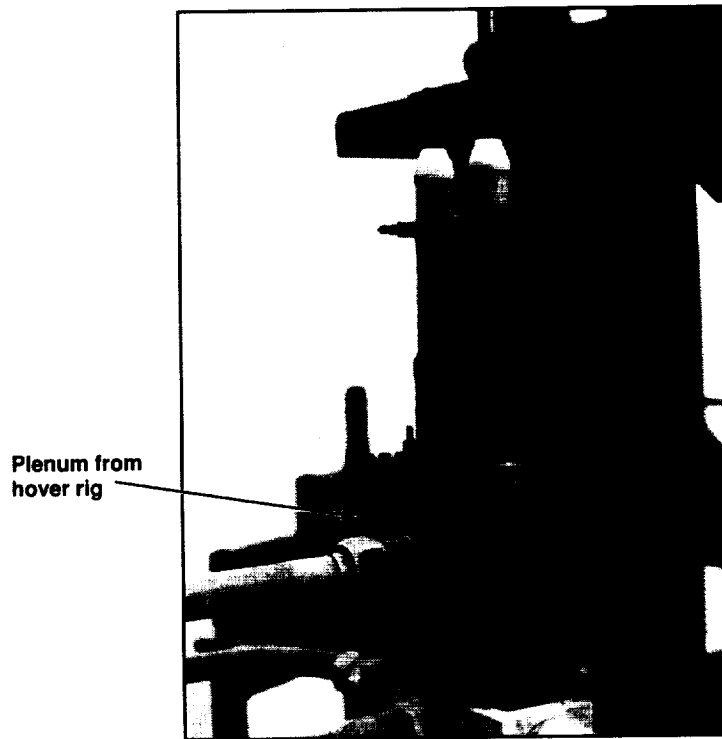

(c) 3.8-in-spaced side-by-side nozzles.

Figure 5. Concluded.

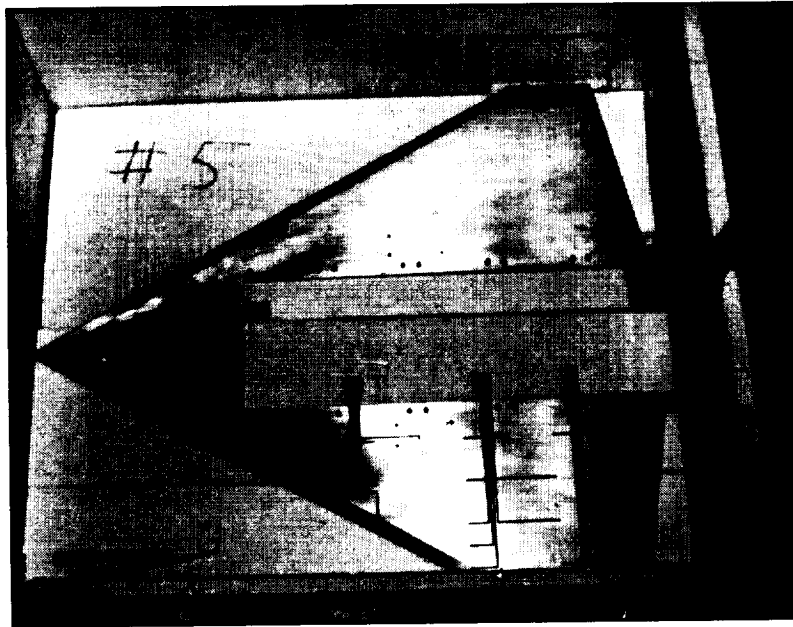

*(a) Delta-wing planform section.*

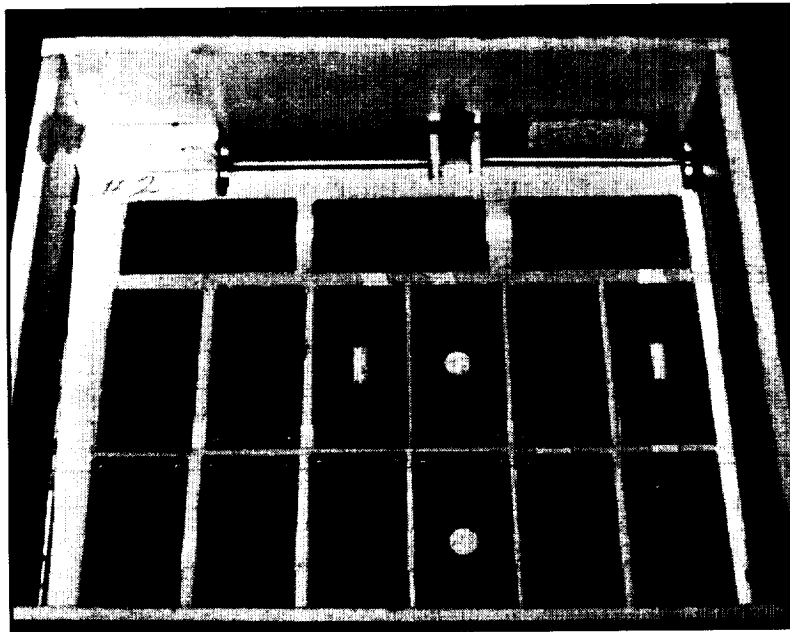

*(b) Rectangular planform sections.*

*Figure 6. Planform sections for model configurations.*

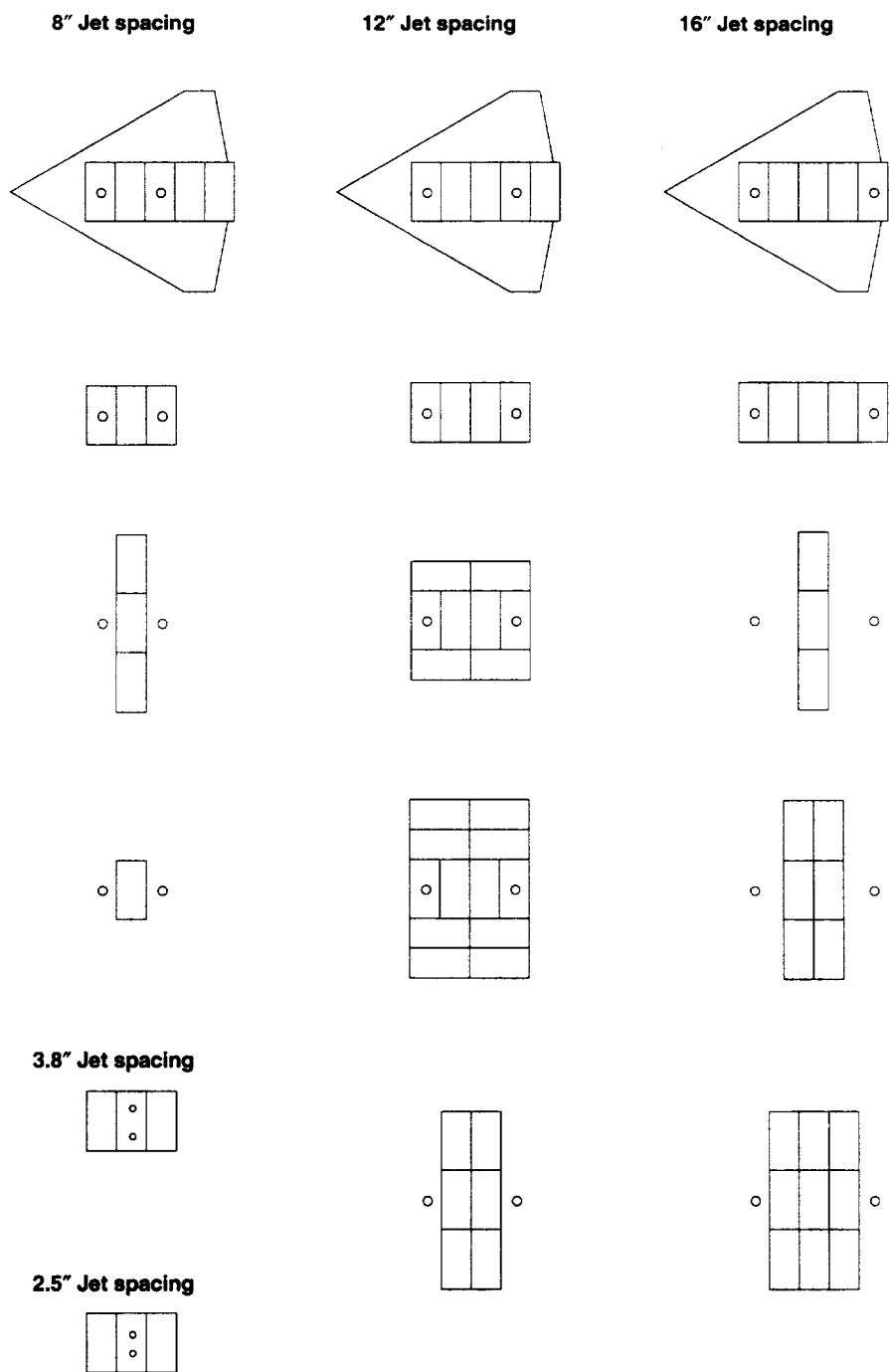

(a) Two-jet configurations, circular jets.

Figure 7. Summary of configurations tested.



**8" Jet spacing**

**12" Jet spacing**

**16" Jet spacing**

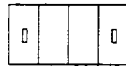
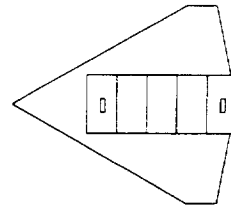
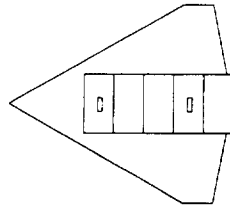
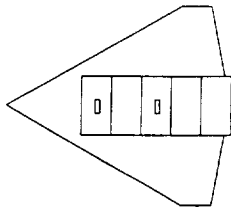

*(b) Two-jet configurations, rectangular jets.*

**8" Jet spacing**

**12" Jet spacing**

**16" Jet spacing**

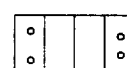
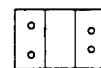
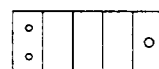
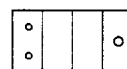
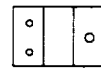
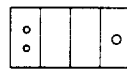
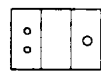
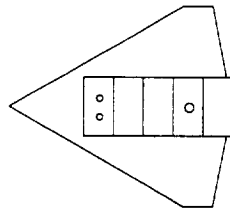
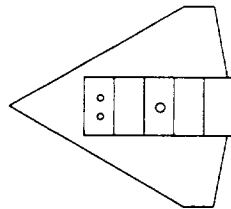

*(c) Three- and four-jet configurations, circular jets.*

*Figure 7. Concluded.*

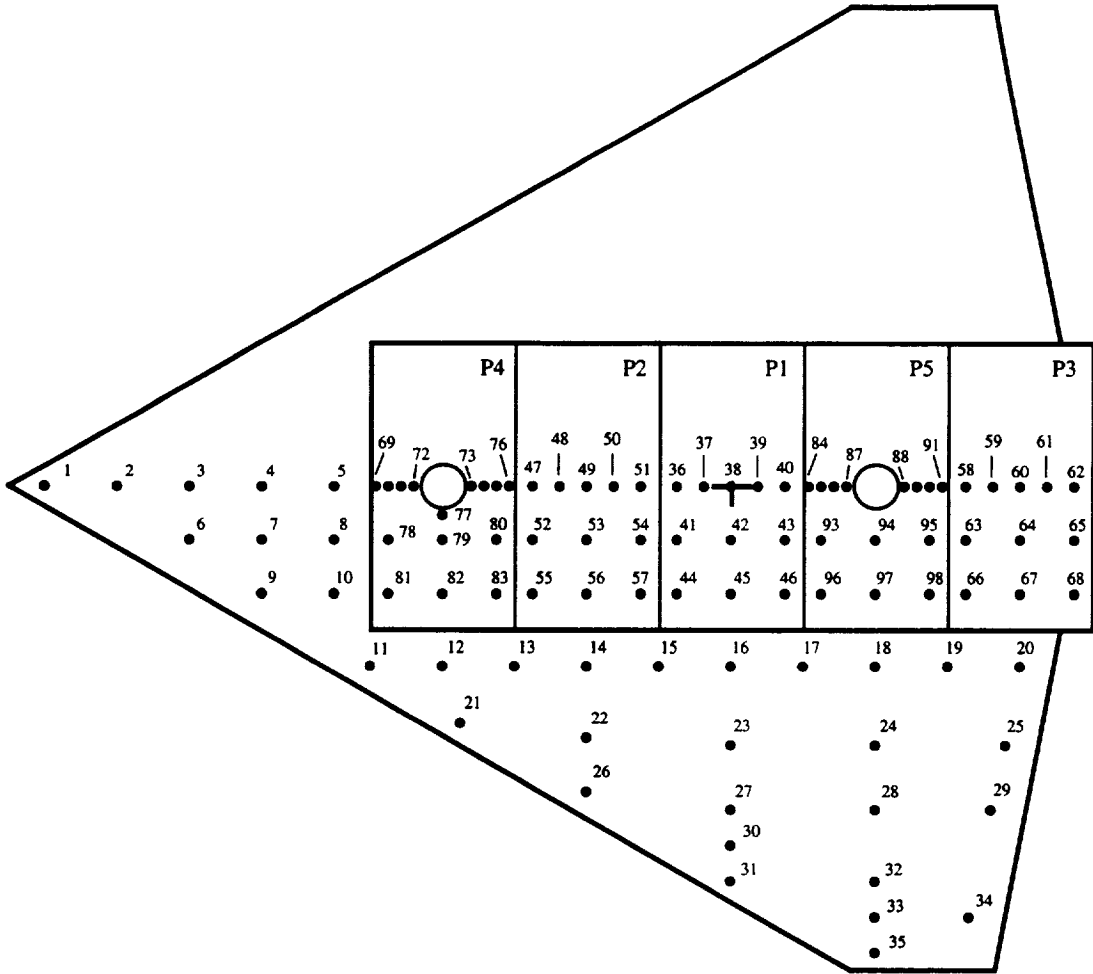

Figure 8. Pressure-tap layout for the two-jet delta wing configuration (2C\_12\_0\_DW).

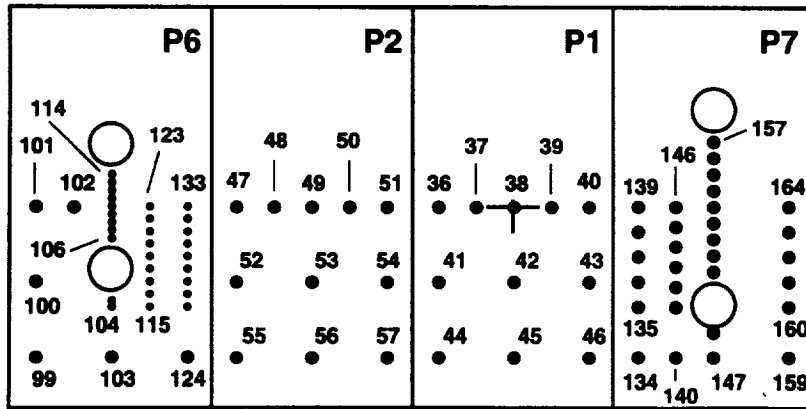

Figure 9. Pressure-tap layout showing pressure taps between side-by-side jets (4C\_12\_2.5/3.9\_16/8).

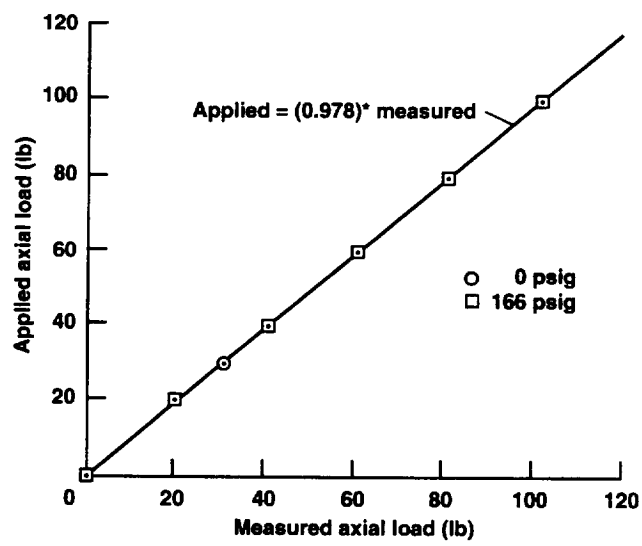

Figure 10. Applied versus measured axial loading for 0 and 166 psig jet calibration rig (JCR) coil pressure.

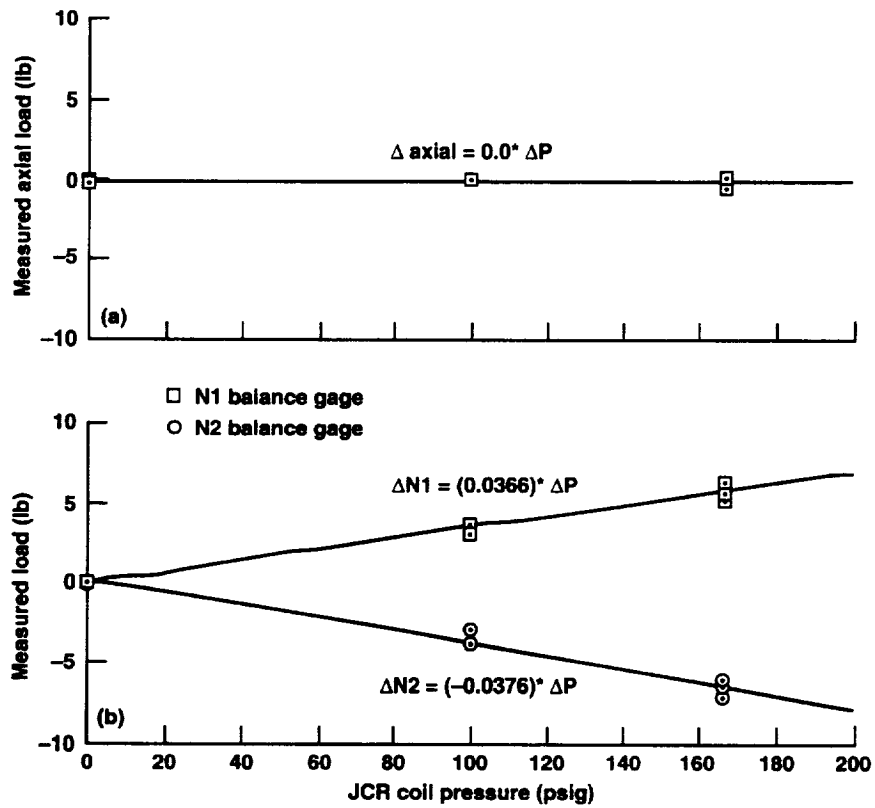

Figure 11. Effect of pressure on the balance N1, N2, and axial force gages.

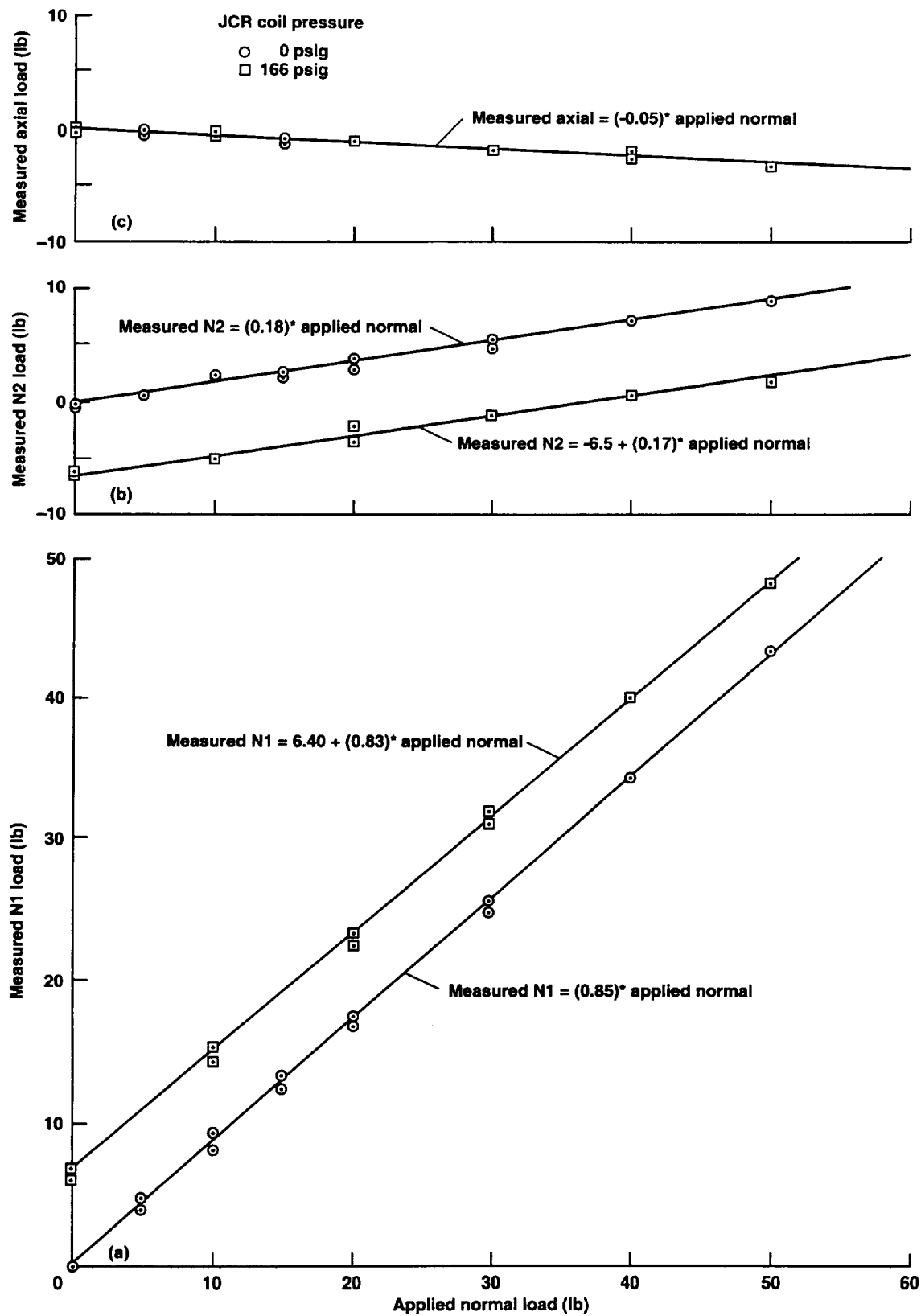

Figure 12. Effects of coil pressure and normal-force loading on balance gages.

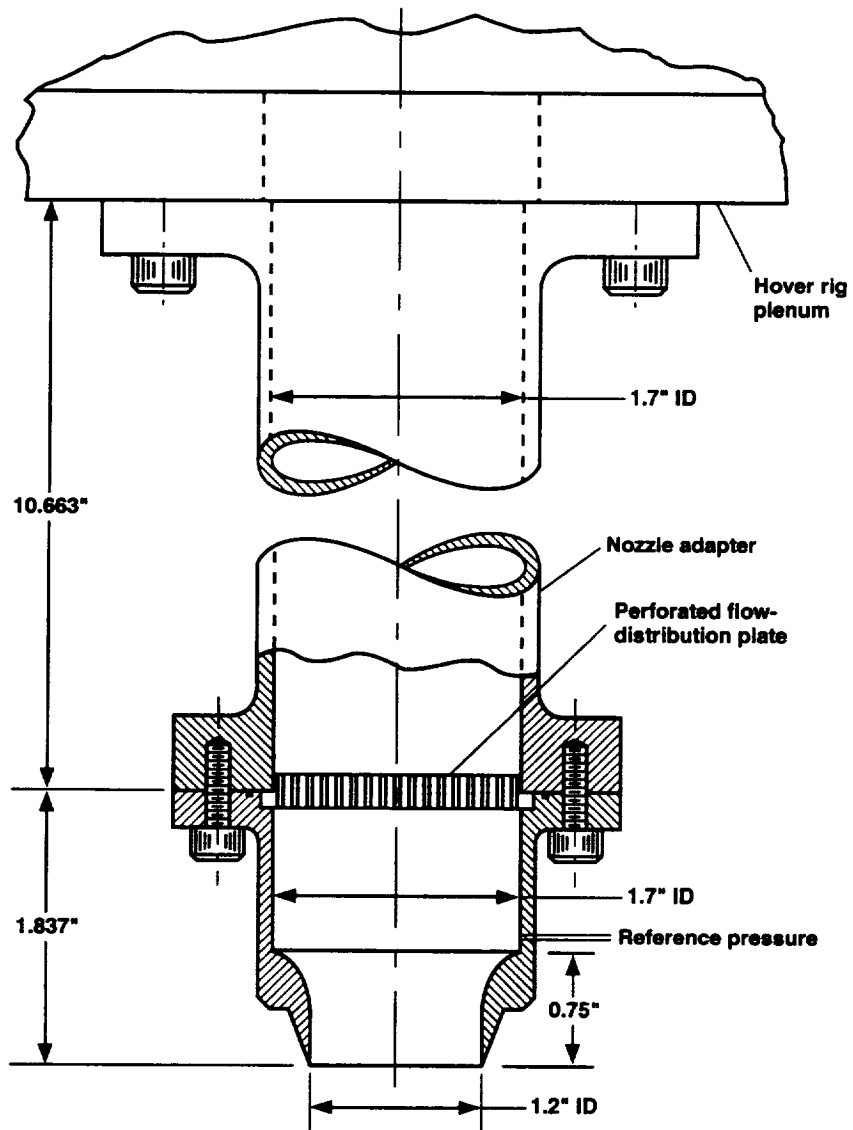
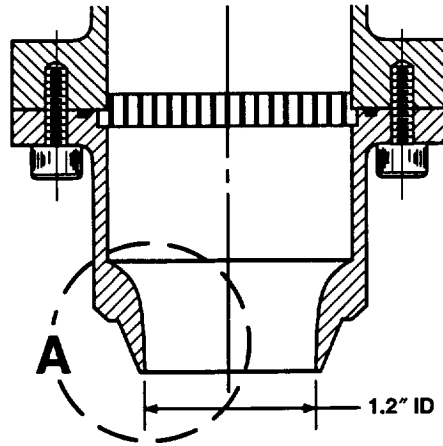

Figure 13. 1.2-in.-diameter nozzle and nozzle adapter; nozzle-types 1 and 2.



X	Y
0.000	0.6000
0.500	0.6022
0.100	0.6091
0.150	0.6209
0.200	0.6385
0.250	0.6637
0.275	0.6800
0.300	0.7000
0.325	0.7253
0.350	0.7602
0.375	0.8500

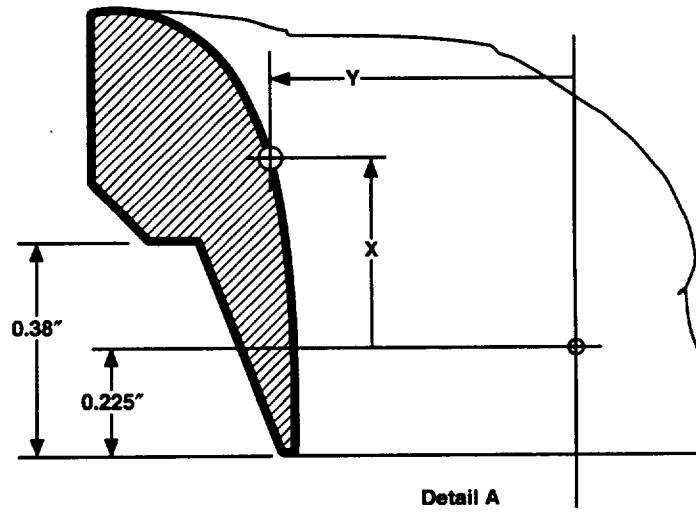

Figure 14. Nozzle contour for nozzle-types 1 and 2.

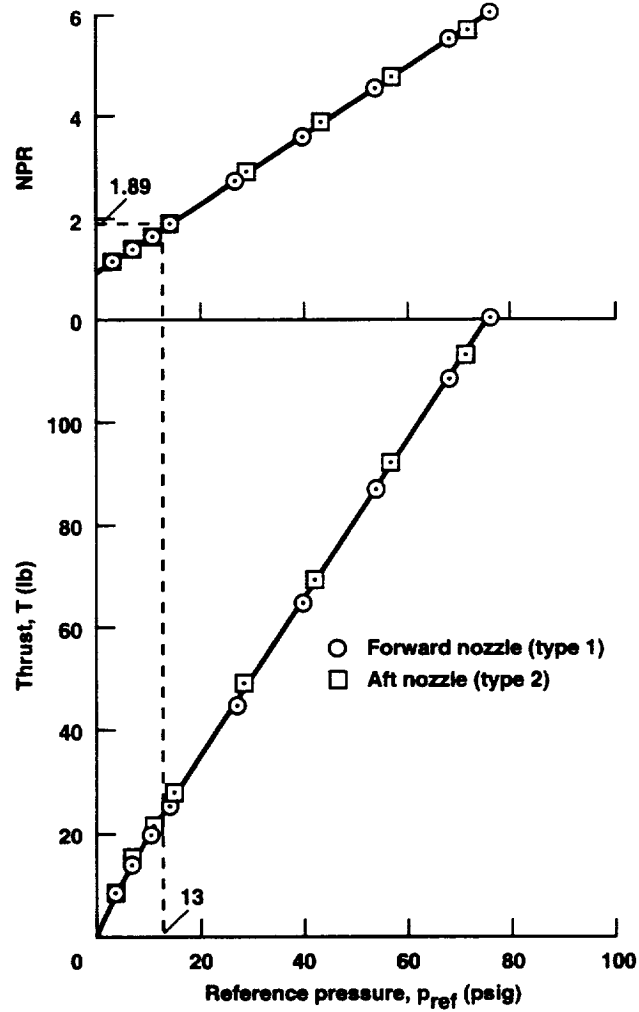

Figure 15. Thrust and nozzle pressure ratio (NPR) calibration of the 1.2-in.-diameter (type 1 and 2) nozzles.



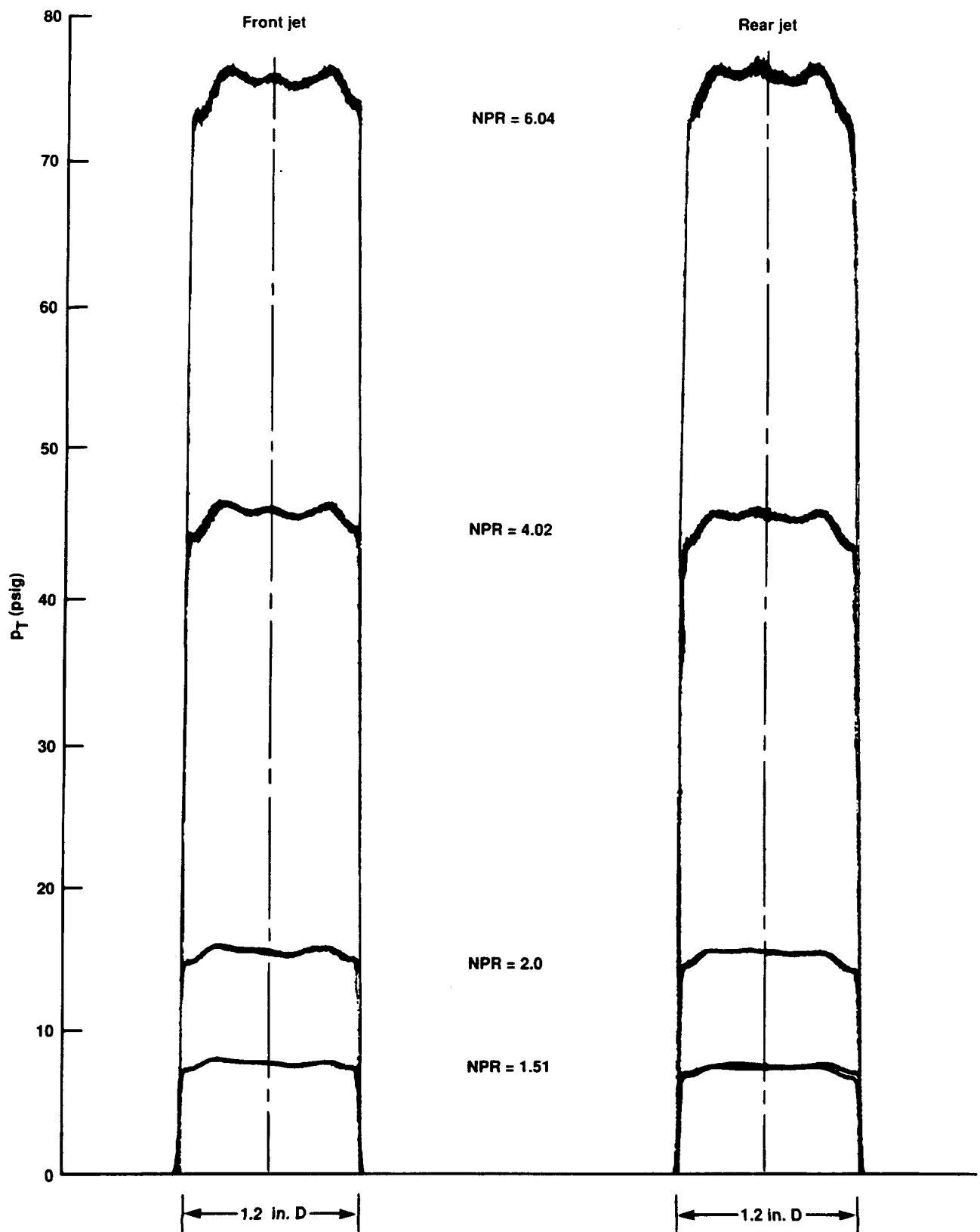

Figure 16. Exit total pressure profiles for the 1.2-in.-diameter (type 1 and 2) nozzles.

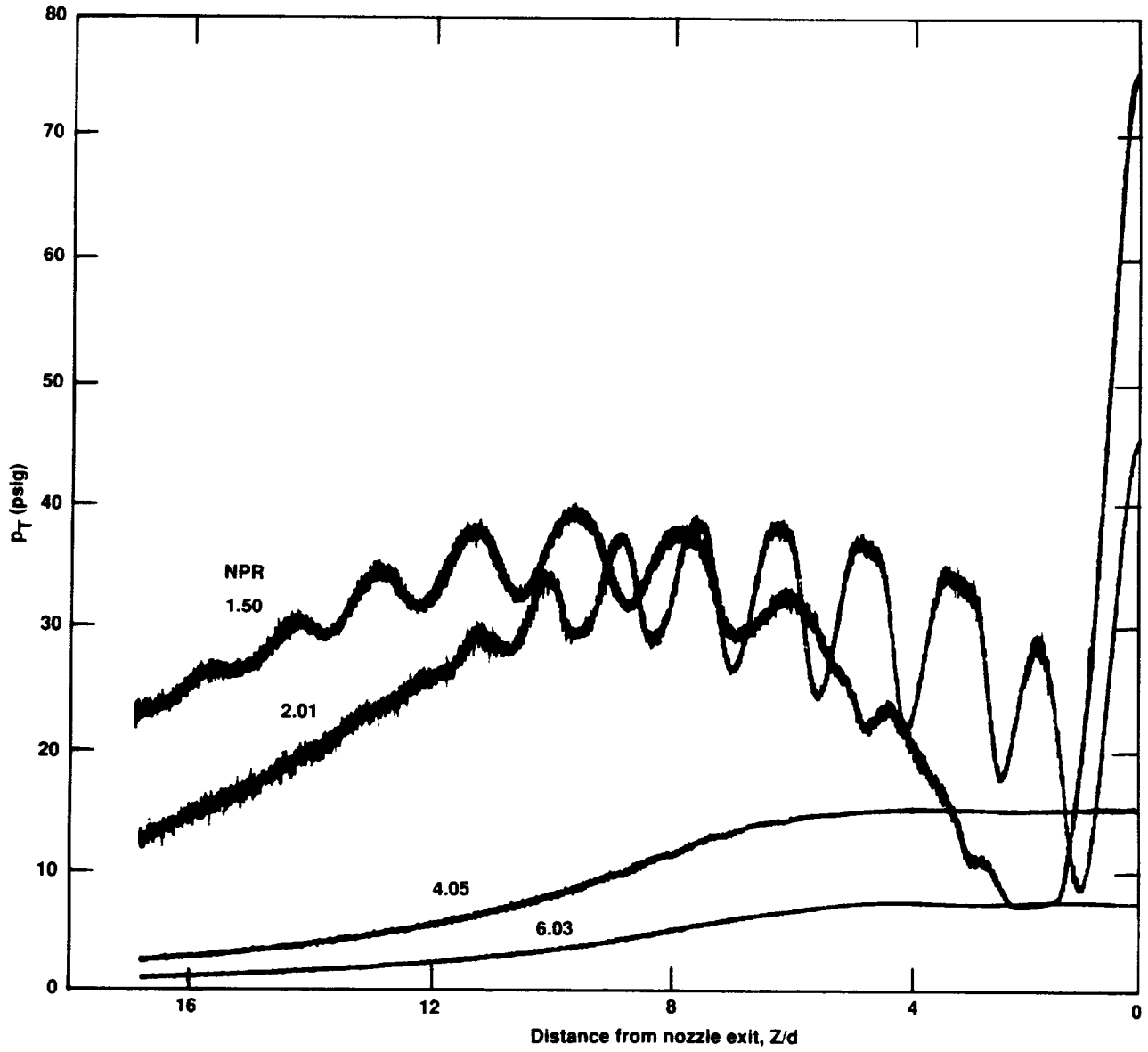

Figure 17. Decay curves for the 1.2-in.-diameter (type 1 and 2) nozzles.

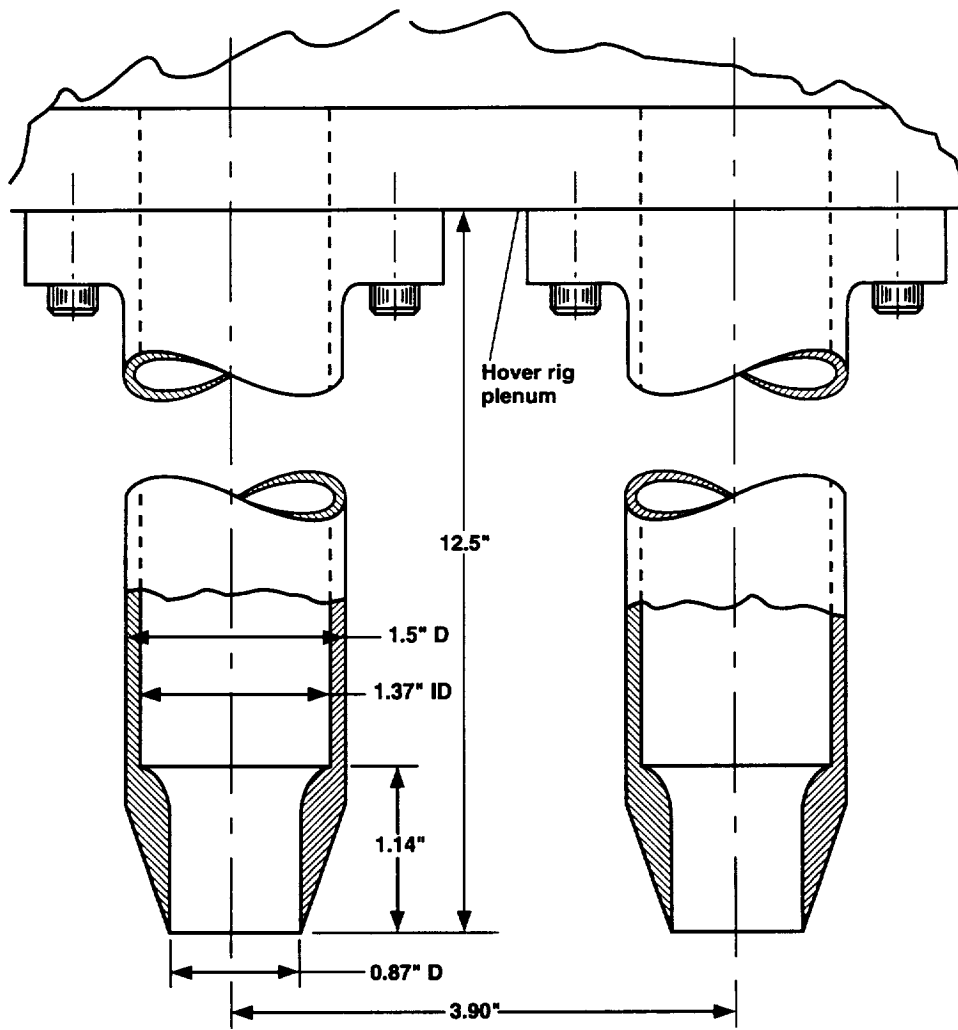

Figure 18. Nozzle-type 3, 0.87-in.-diameter, side-by-side nozzles (3.9 in. spacing).

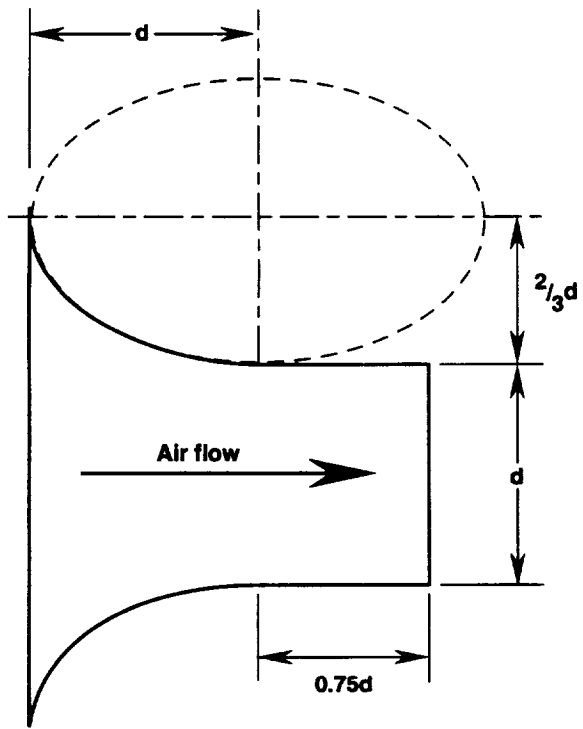

Figure 19. American Society of Mechanical Engineers (ASME) long-radius nozzle definition.

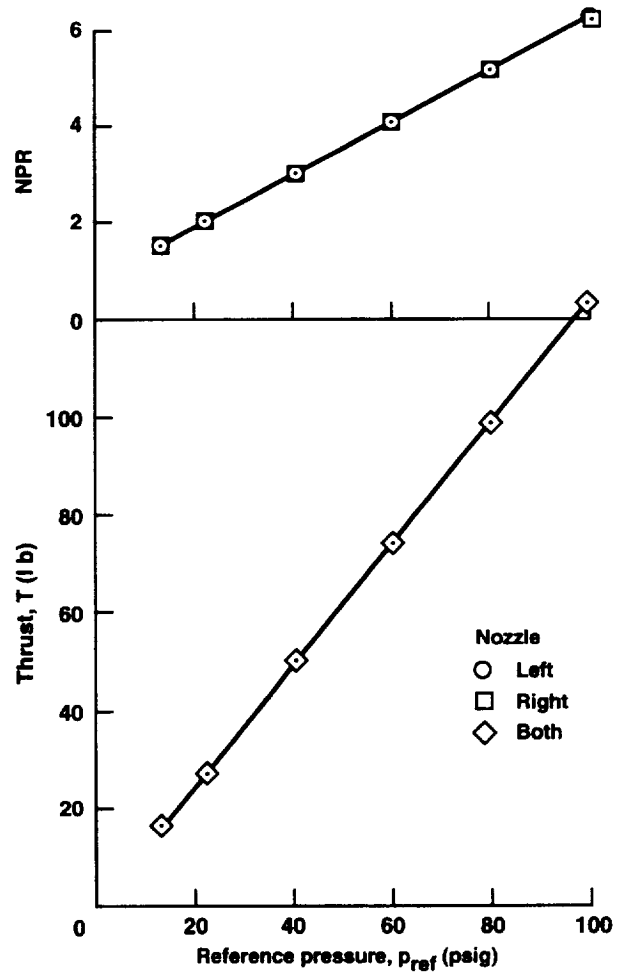

Figure 20. Thrust and nozzle pressure ratio (NPR) calibration of the 3.9-in.-spaced side-by-side (type 3) nozzles.

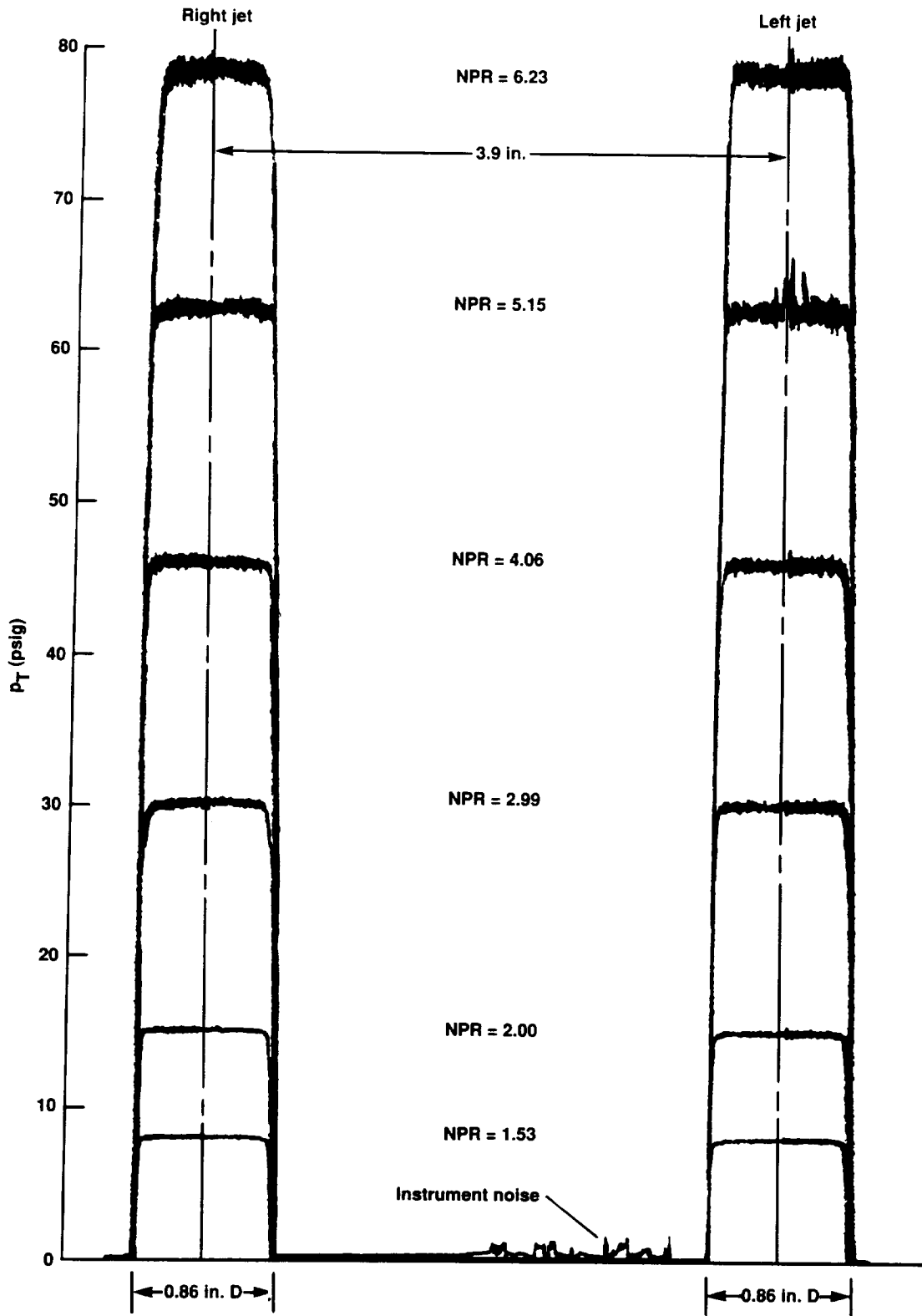
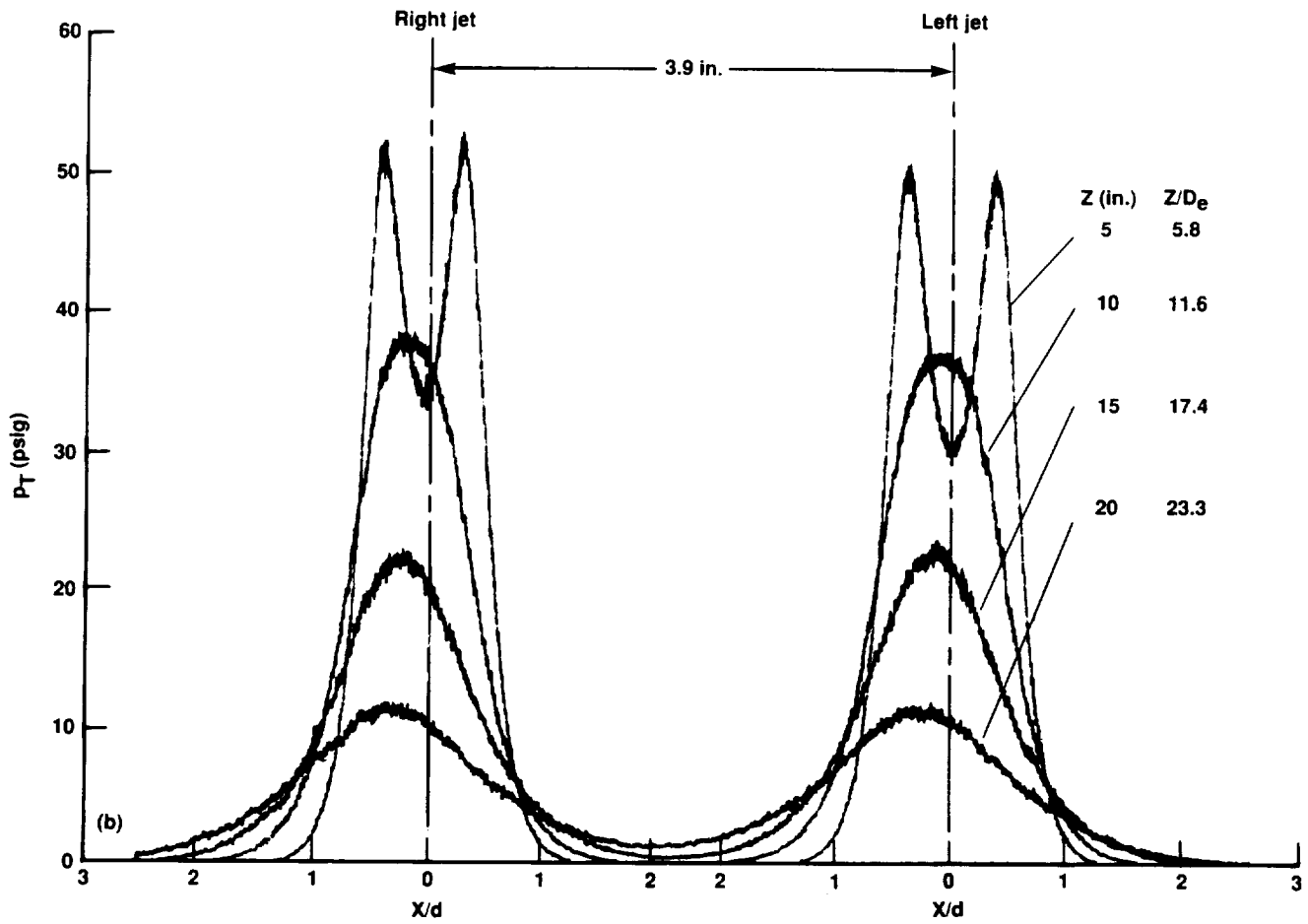

Figure 21. Exit total-pressure profiles for the 3.9-in.-spaced side-by-side (type 3) nozzles.





(b) Nozzle pressure ratio (NPR) = 6.2.

Figure 22. Concluded.

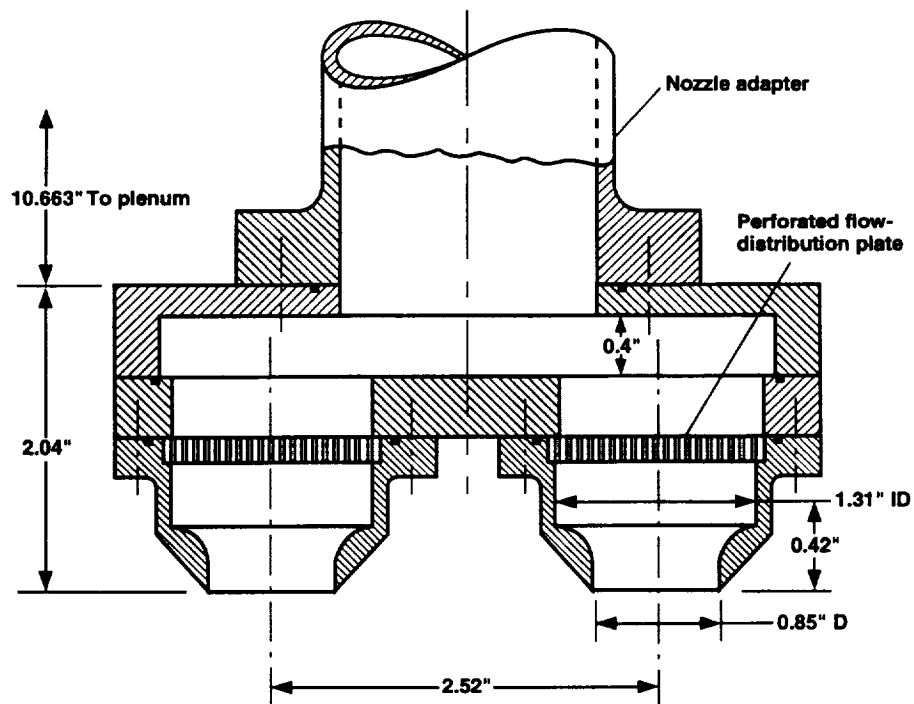

Figure 23. Nozzle-type 4, 0.85-in.-diameter side-by-side nozzles (2.52 in. spacing).

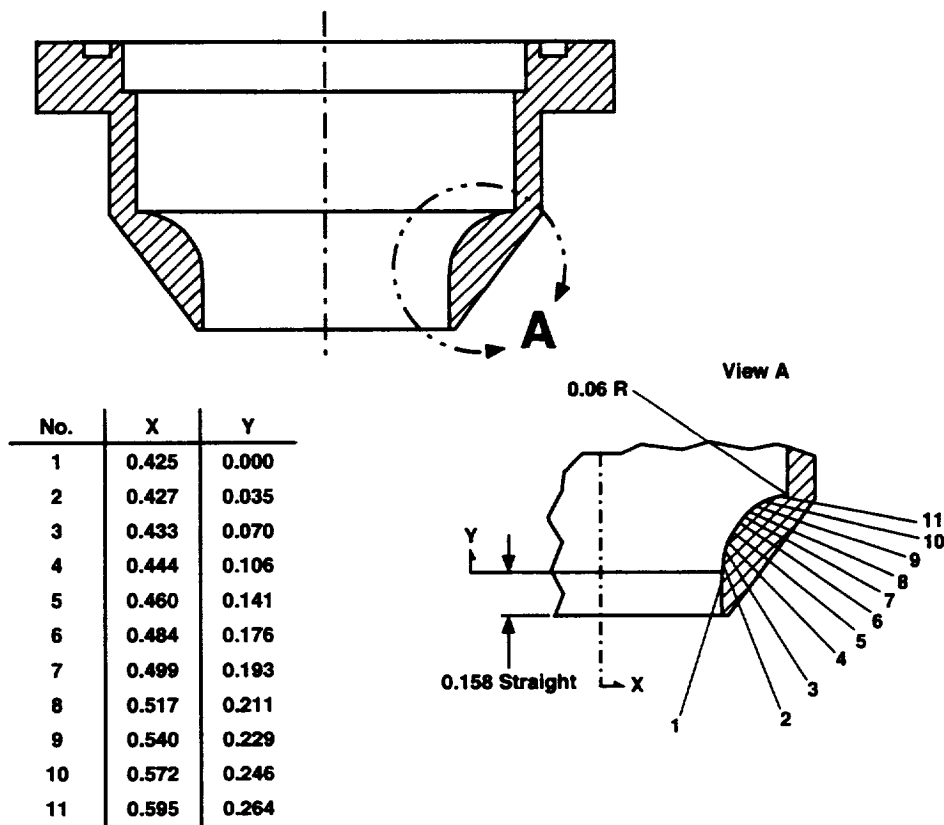

Figure 24. Exit contour details for nozzle-type 4.



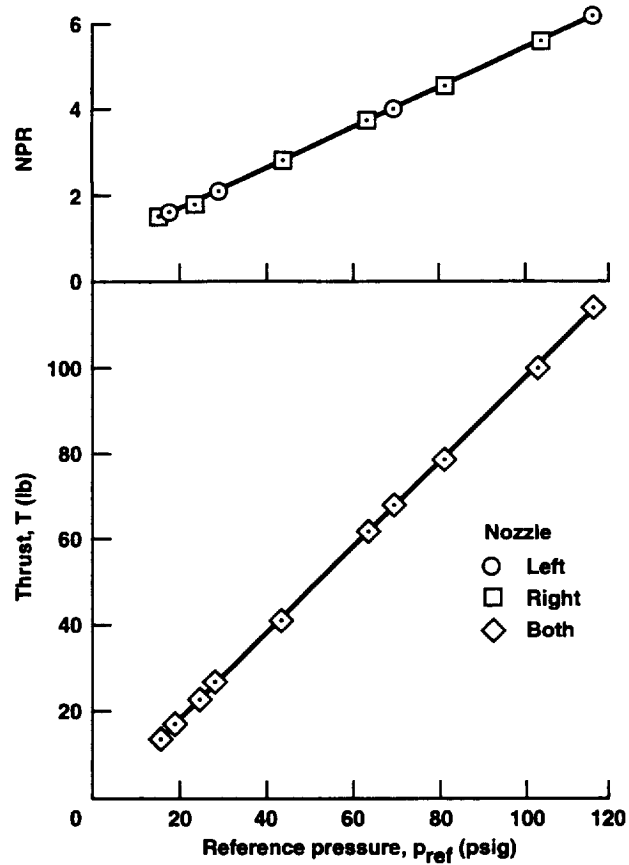

Figure 25. Thrust and nozzle pressure ratio (NPR) calibration of the 2.52-in.-spaced side-by-side (type 4) nozzles.

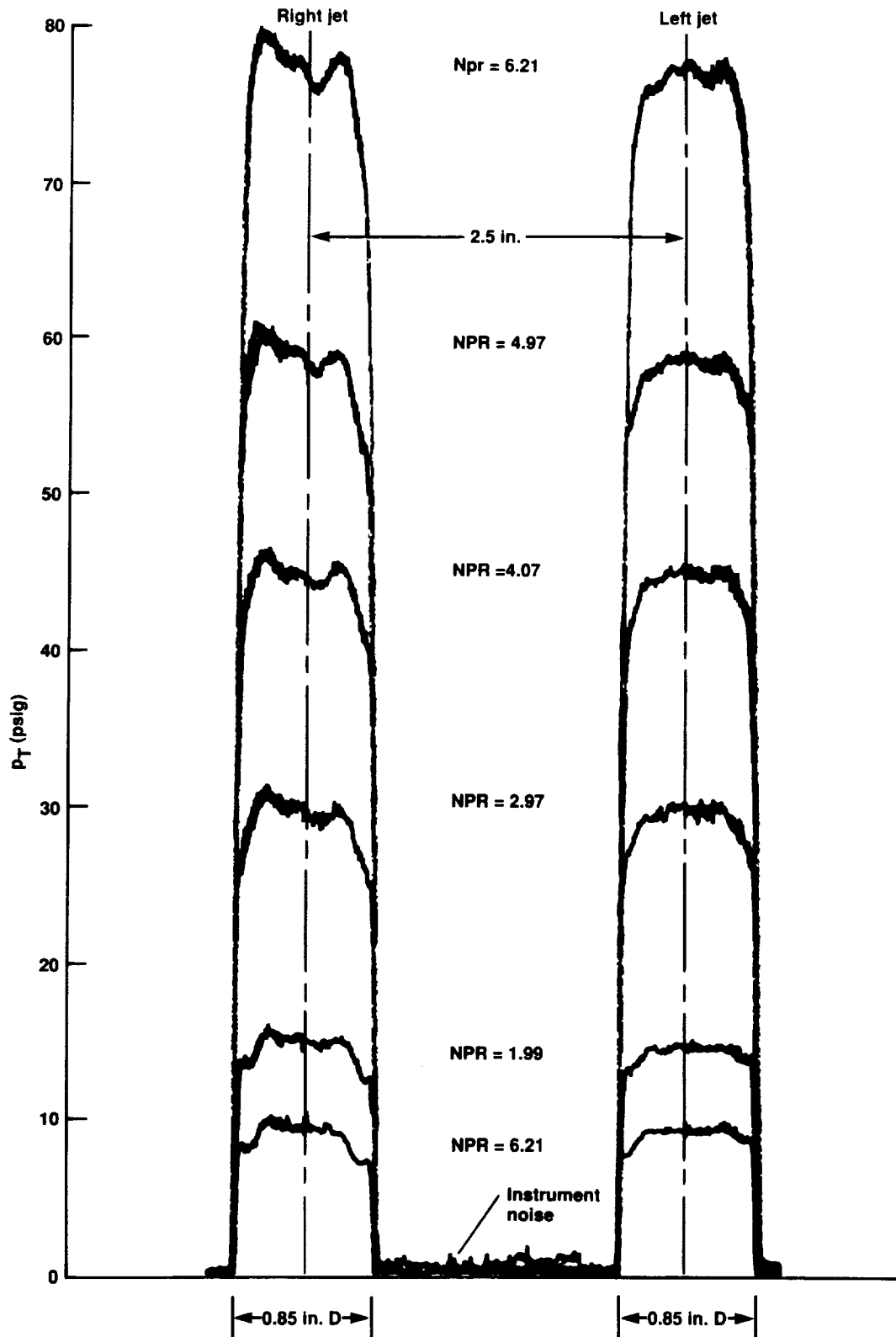
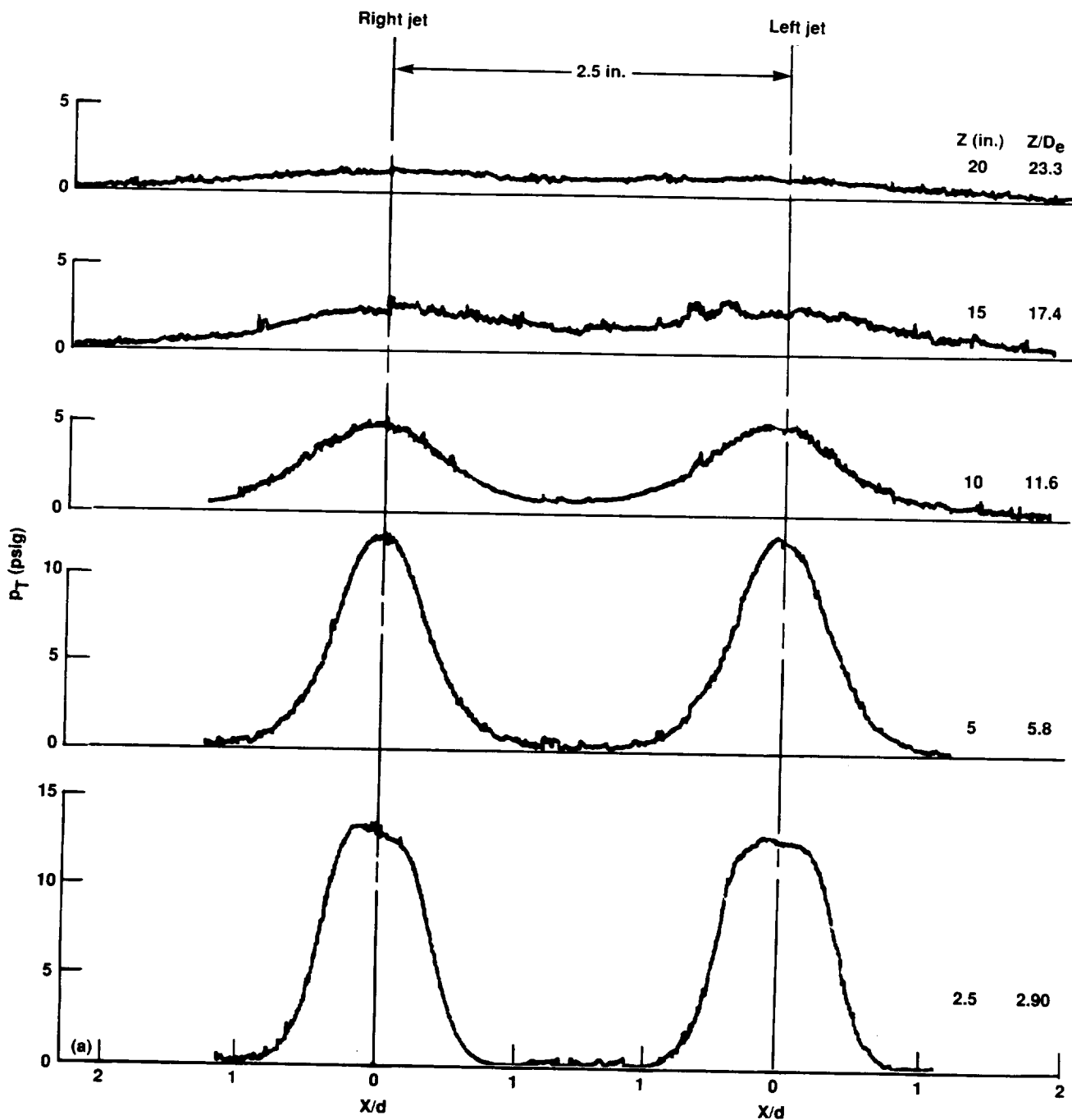
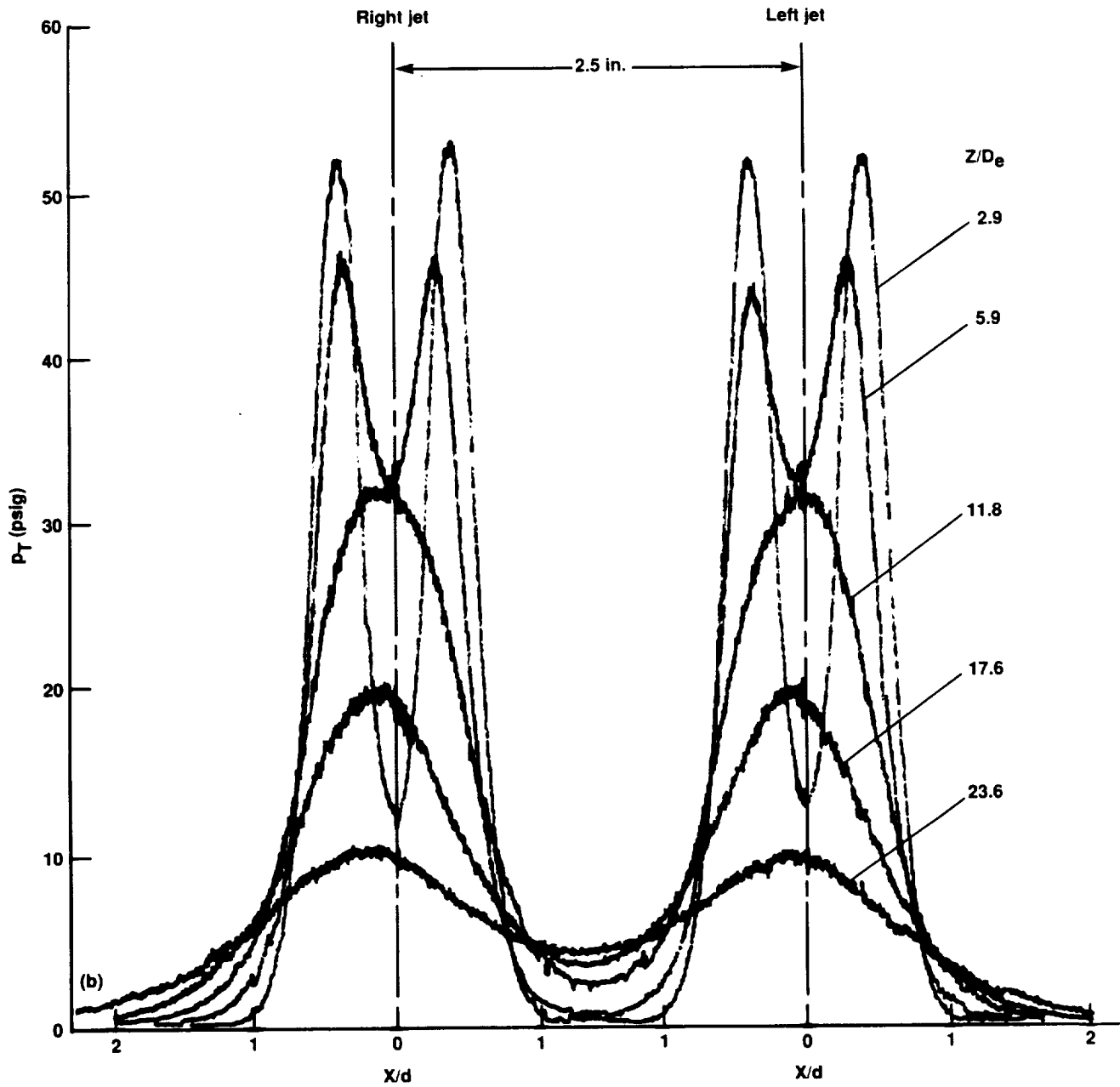

Figure 26. Exit total-pressure profiles for the 2.52-in.-spaced side-by-side (type 4) nozzles.



(a) Nozzle pressure ratio (NPR) = 2.0.

Figure 27. Total-pressure profiles at various distances downstream from the exits of the 2.52-in.-spaced side-by-side (type 4) nozzles.



(b) Nozzle pressure ratio (NPR) = 6.2.

Figure 27. Concluded.

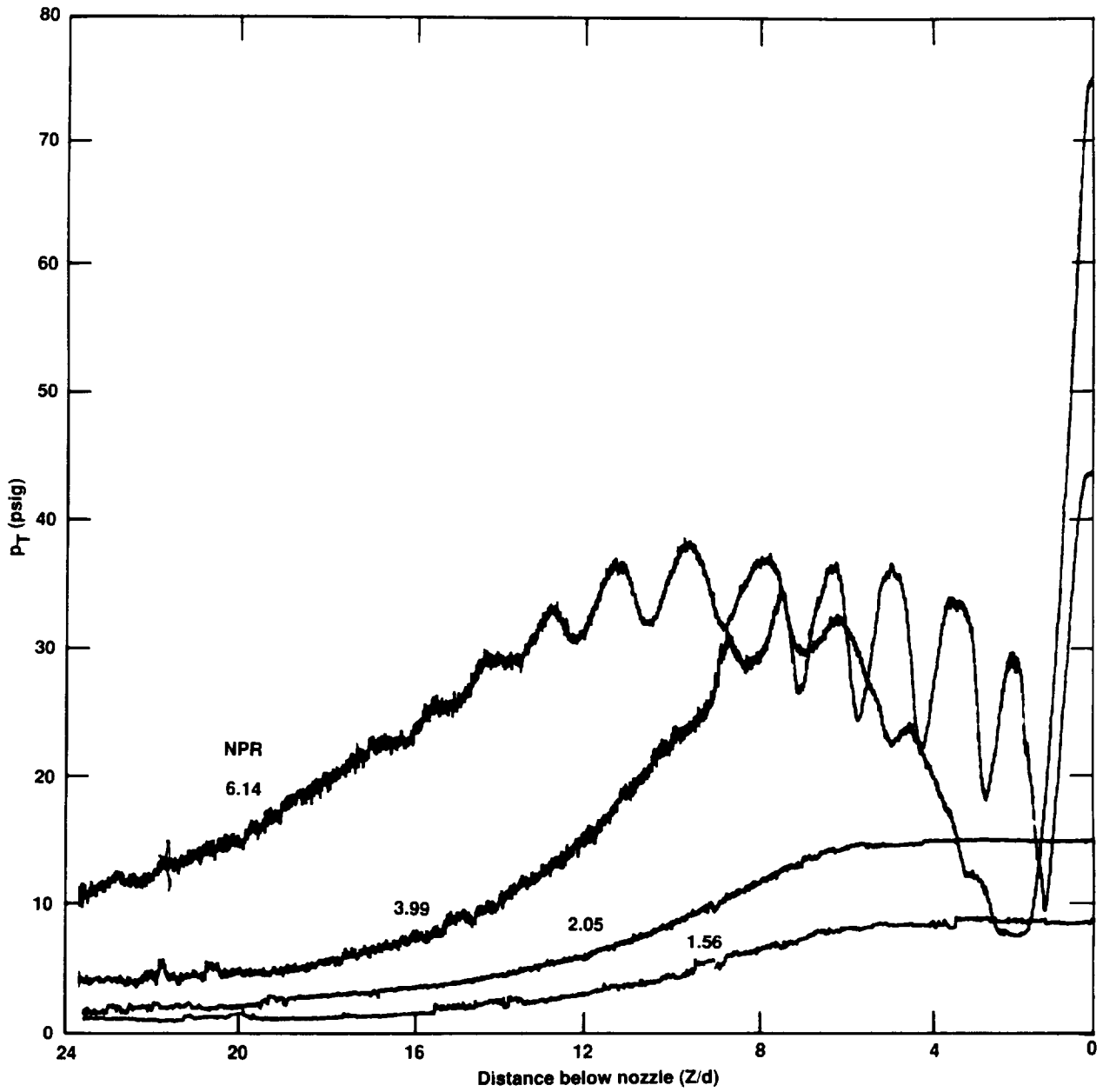

Figure 28. Jet-decay curves for the left jet of the 2.52-in.-spaced side-by-side (type 4) nozzles.

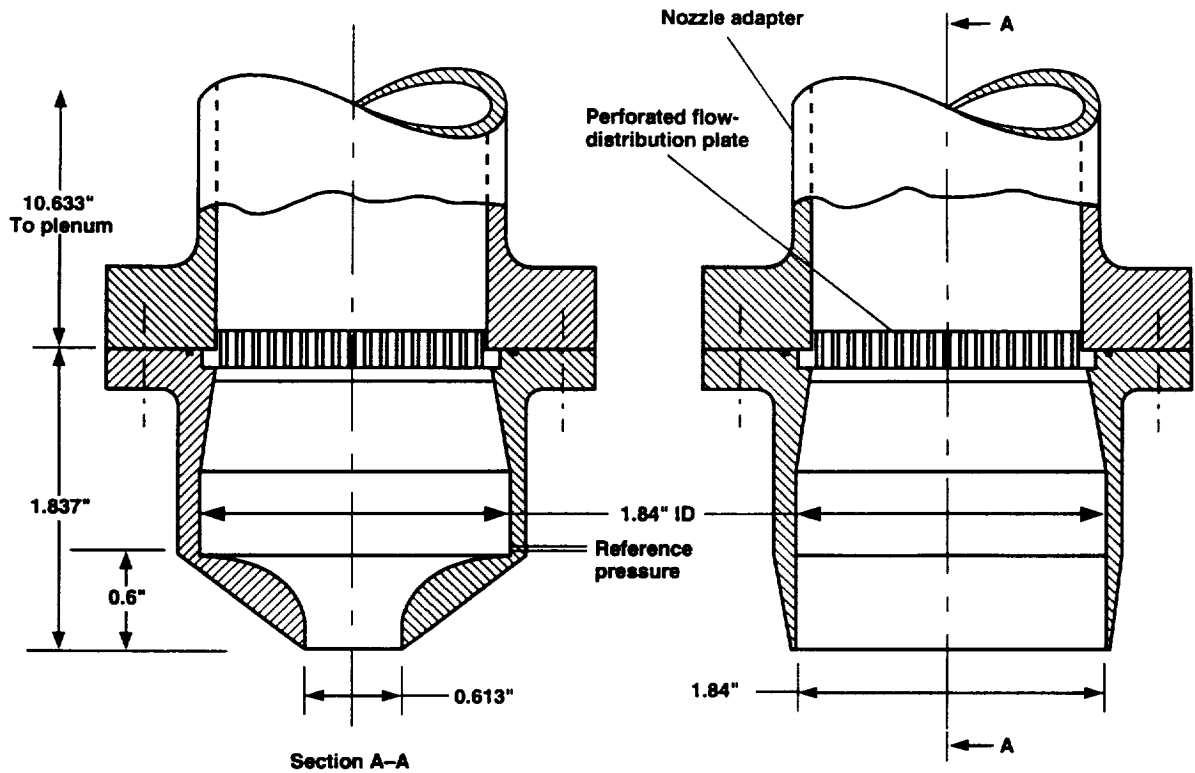

Figure 29. Sketch of the rectangular nozzles (types 5 and 6).

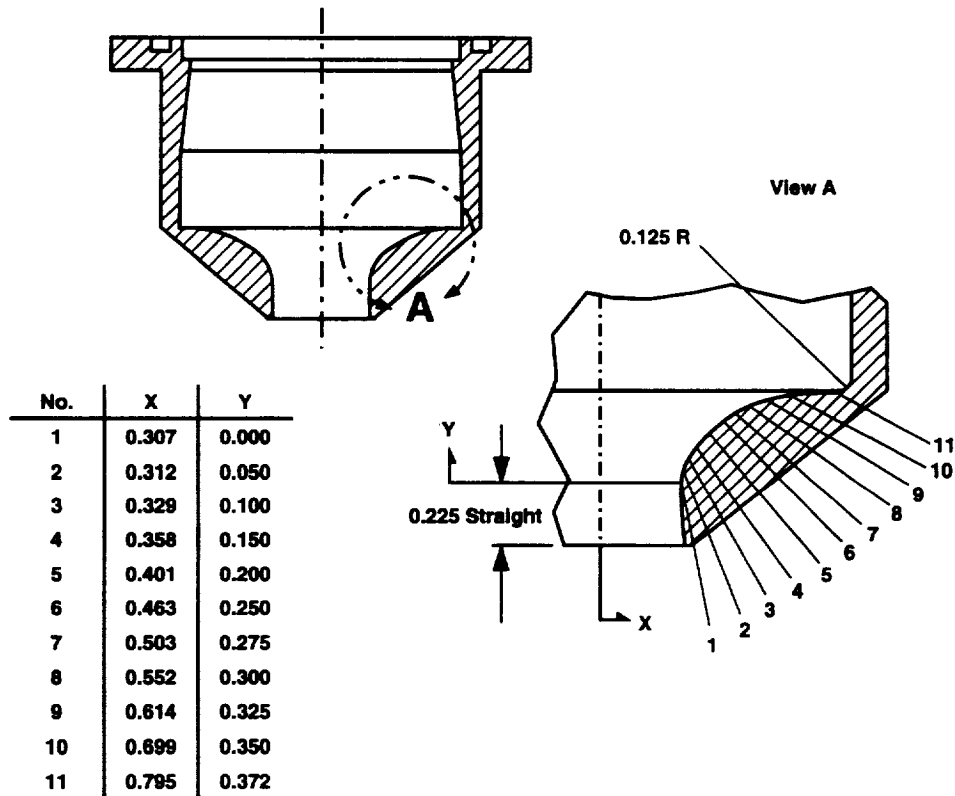

Figure 30. Exit contour detail of the rectangular nozzles (types 5 and 6).

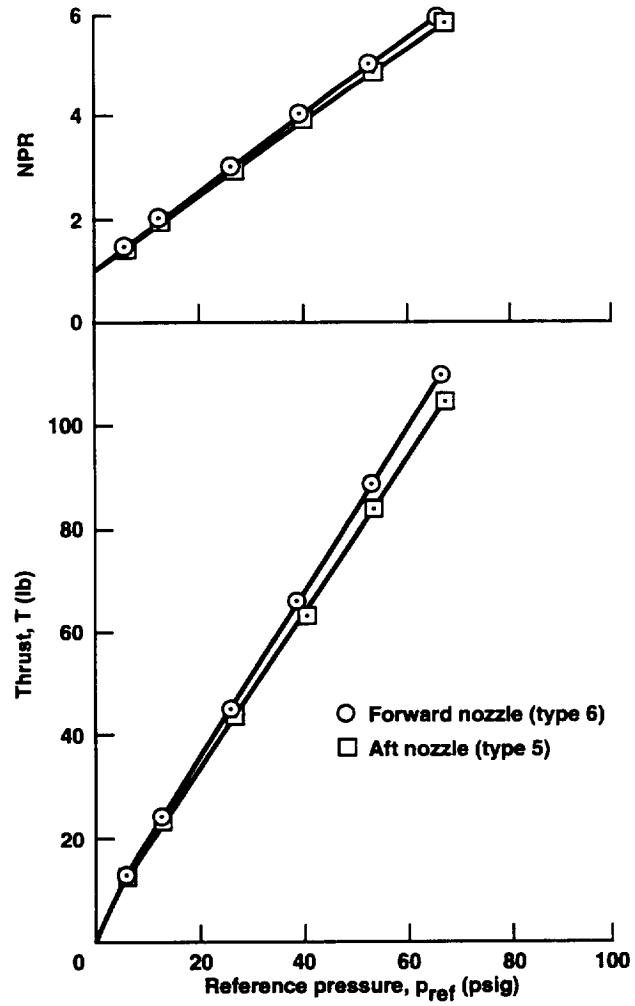

Figure 31. Thrust and nozzle pressure ratio (NPR) calibrations of the rectangular nozzles (types 5 and 6).

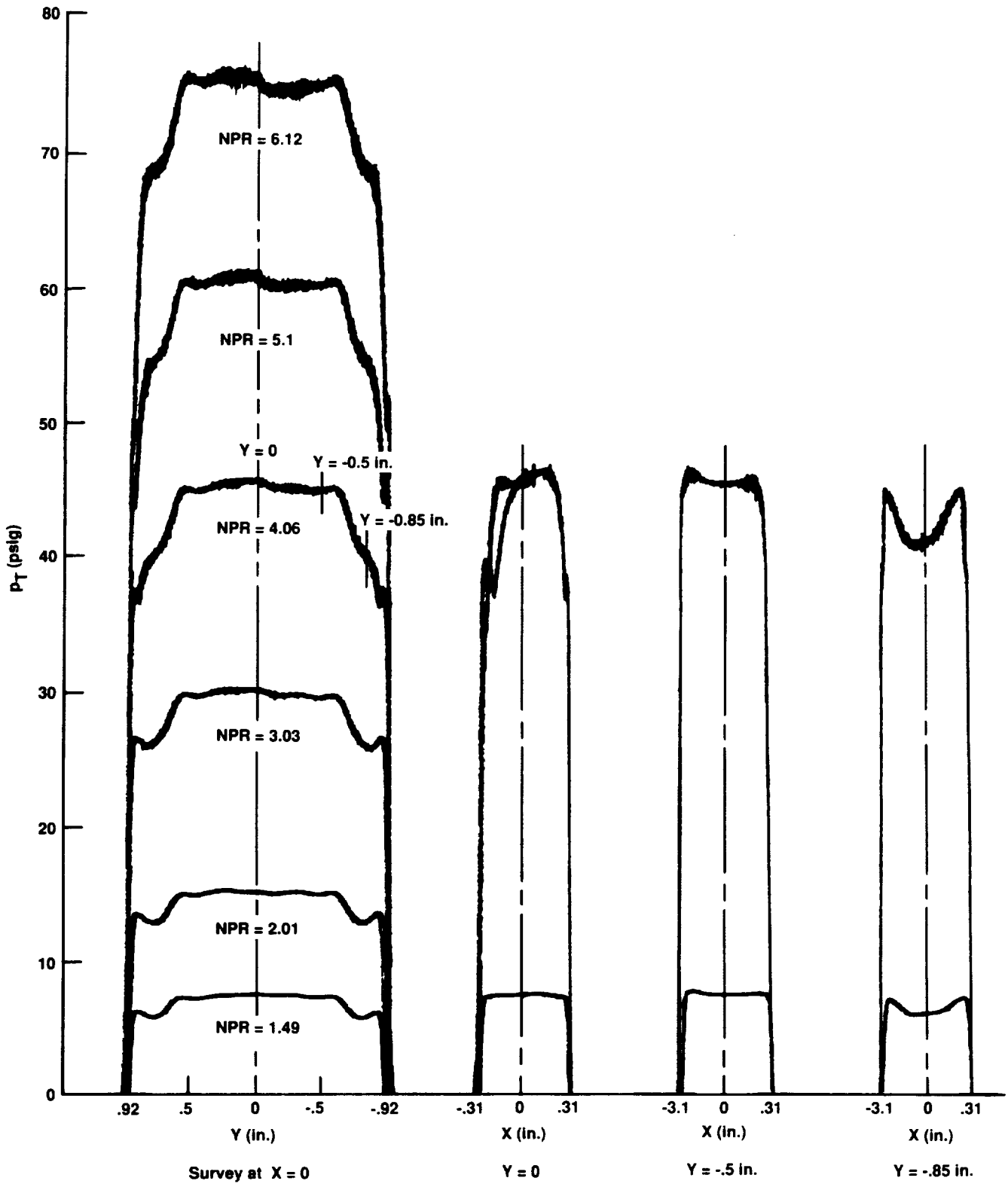

Figure 32. Exit total-pressure profiles for the forward rectangular nozzle (type 6).



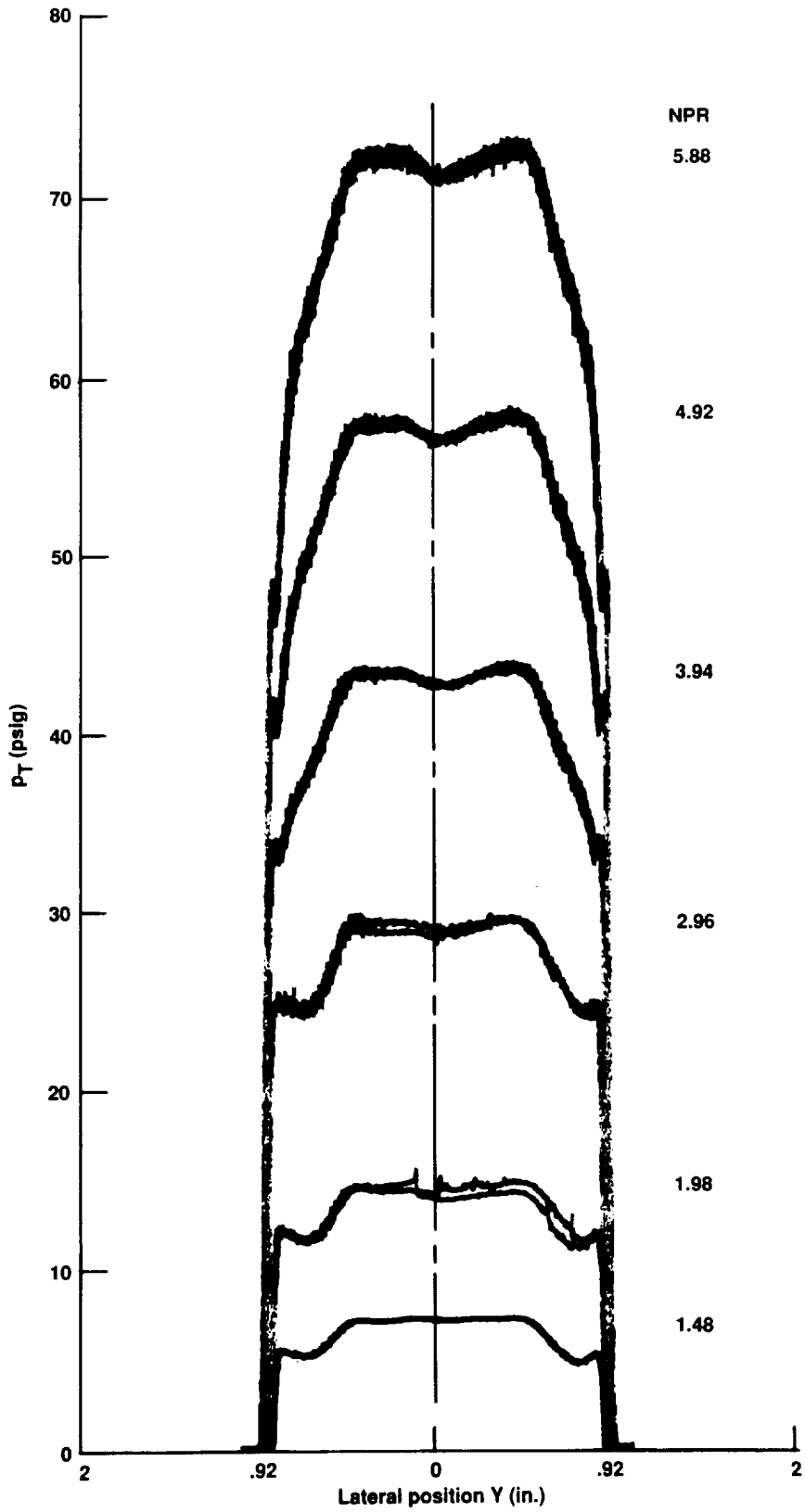
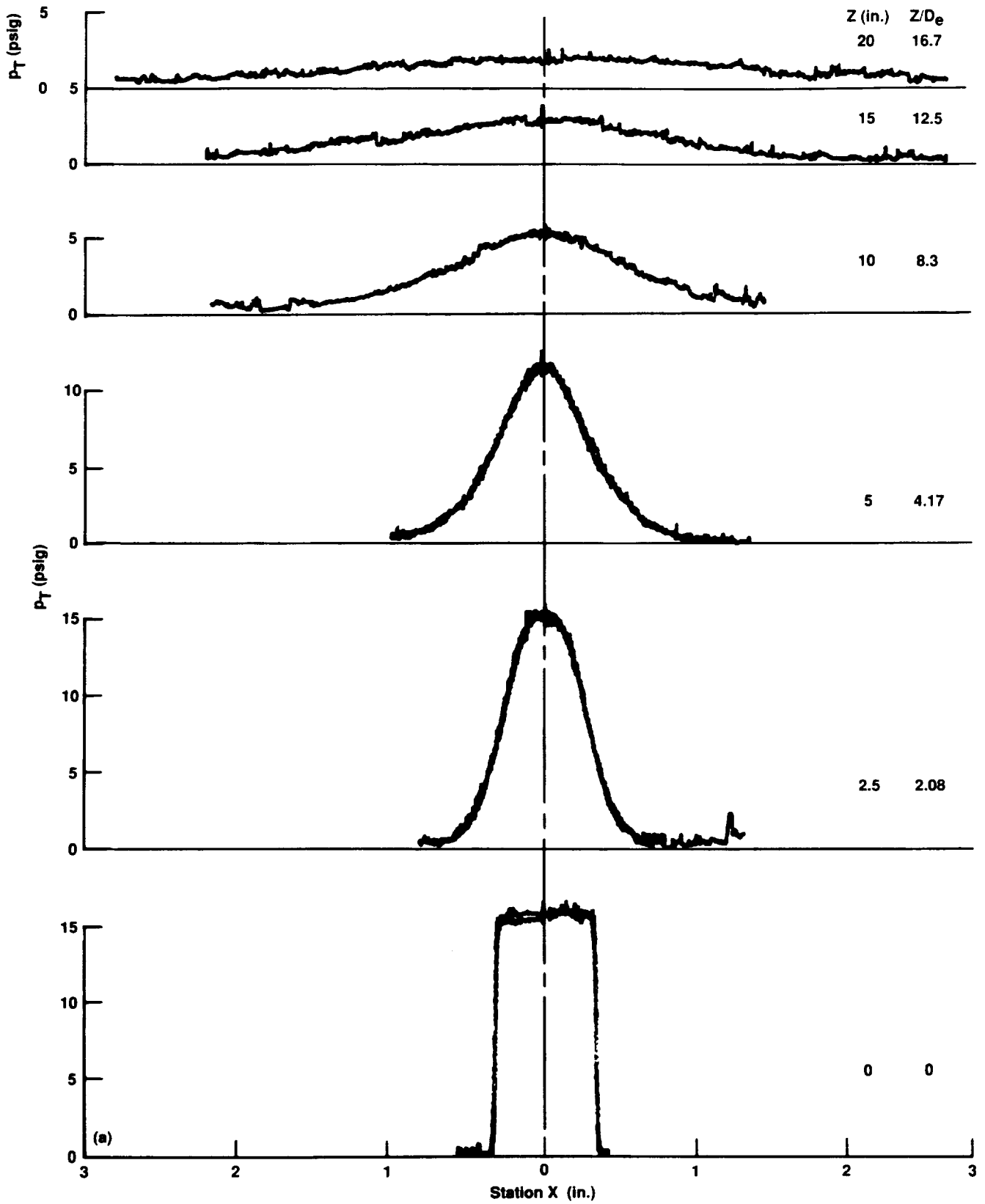
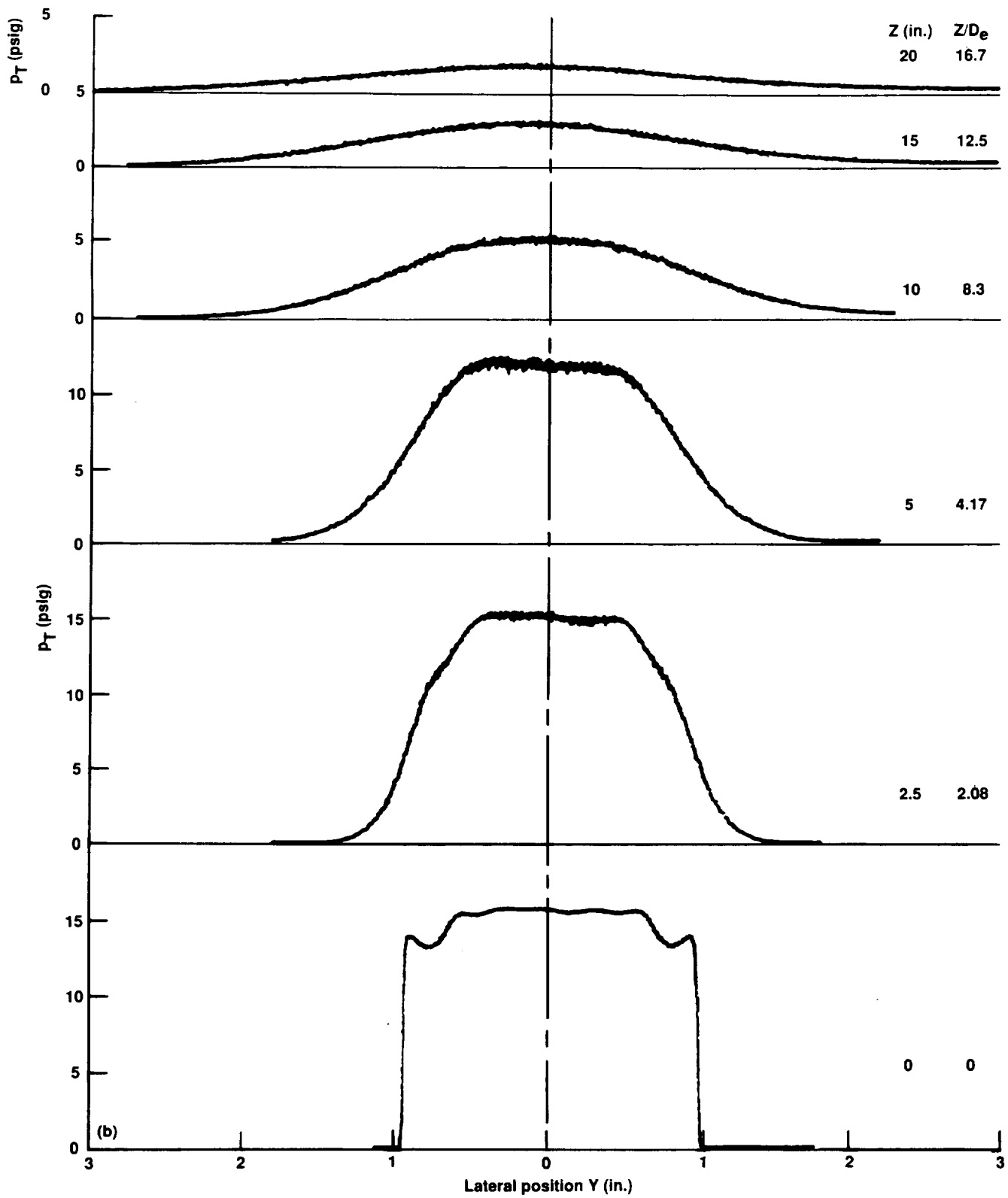

Figure 33. Exit total-pressure profiles for the aft rectangular nozzle (type 5); along the long axis.



(a) Nozzle pressure ratio (NPR) = 2.0, short axis.

Figure 34. Total-pressure surveys at various distances downstream from the exit of the rectangular nozzles.



(b) Nozzle pressure ratio (NPR) = 2.0, long axis.

Figure 34. Continued.

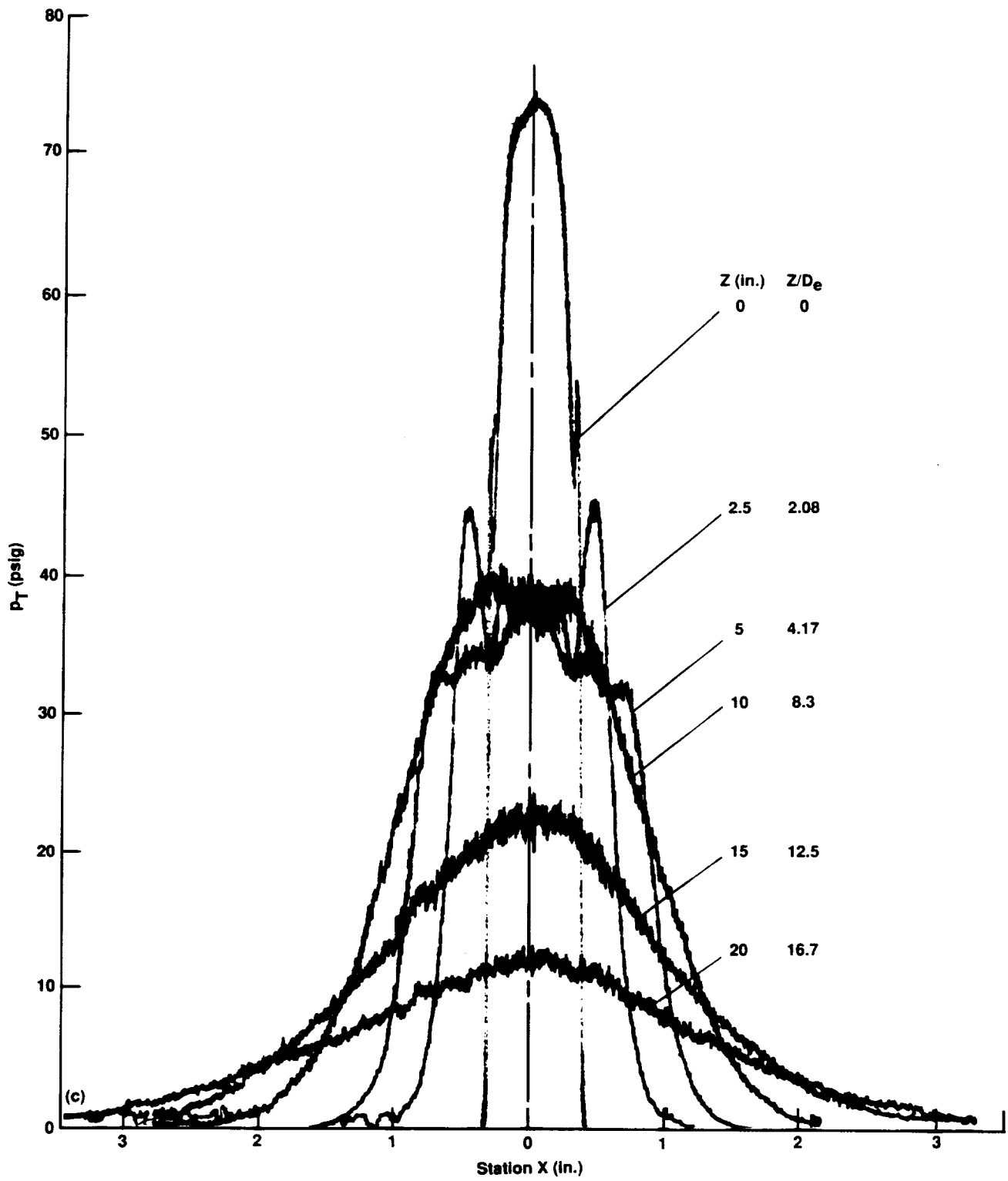

(c) Nozzle pressure ratio (NPR) = 6.0, short axis.

Figure 34. Continued.

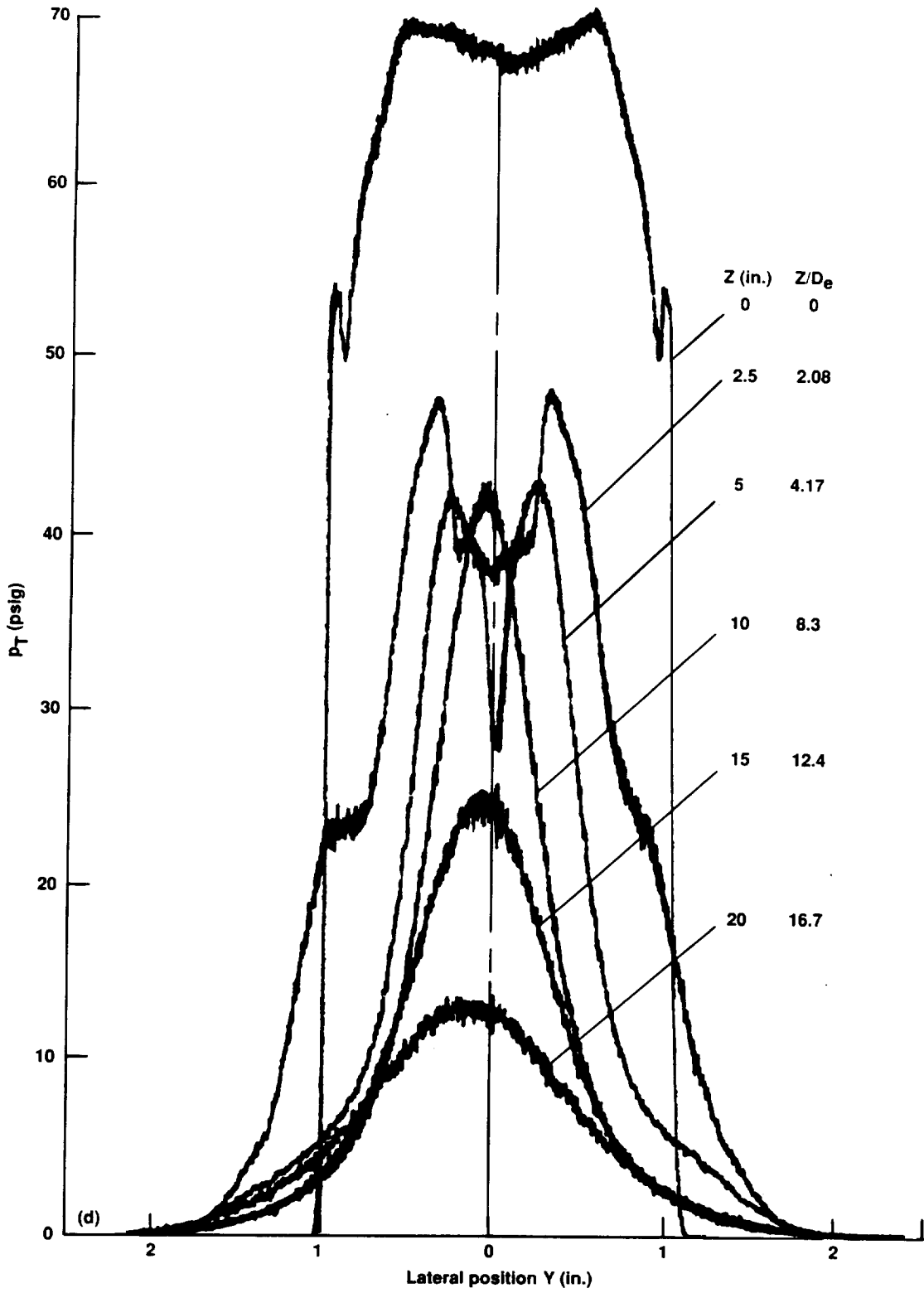

(d) Nozzle pressure ratio (NPR) = 5.8, long axis.

Figure 34. Concluded.

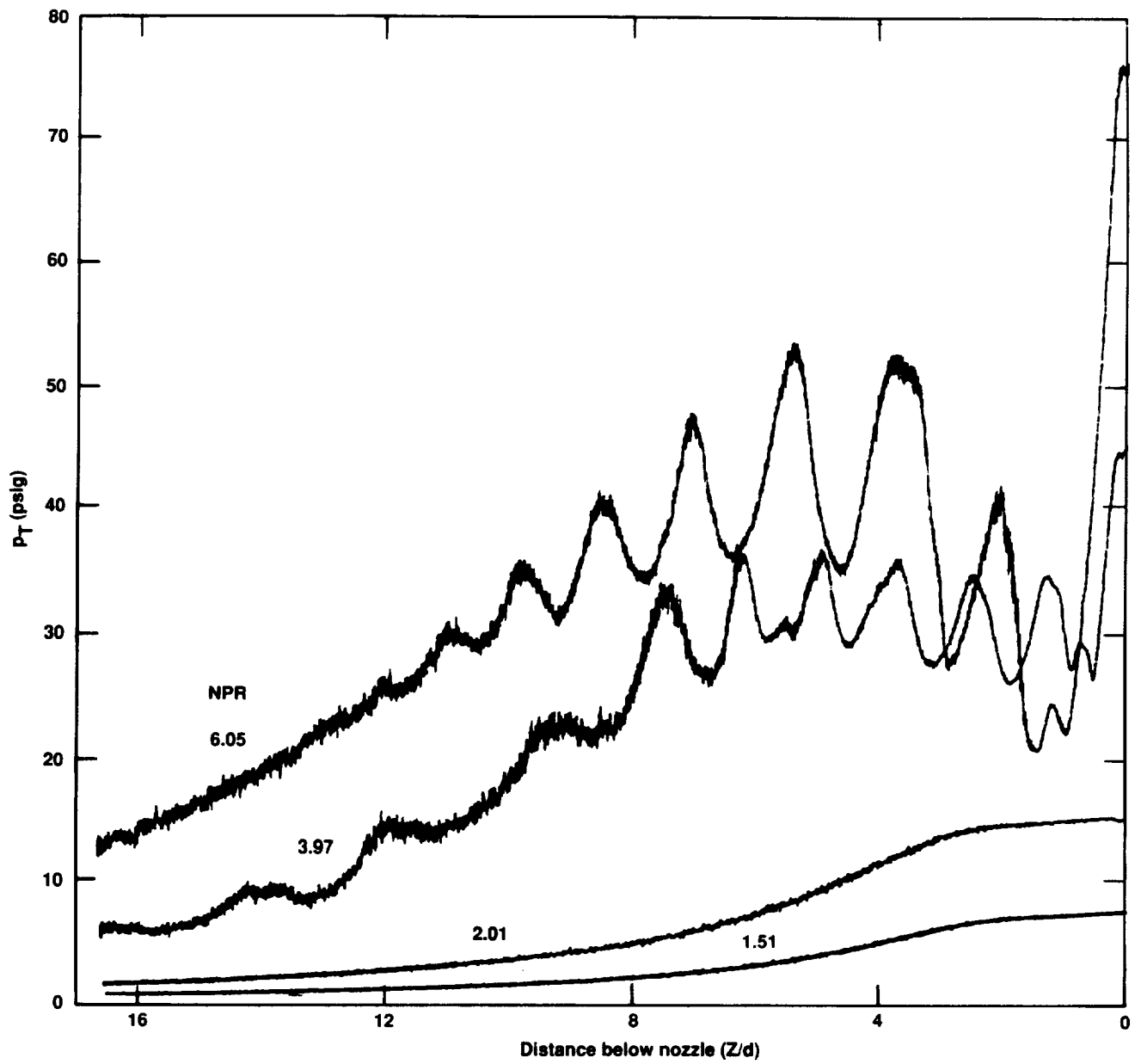
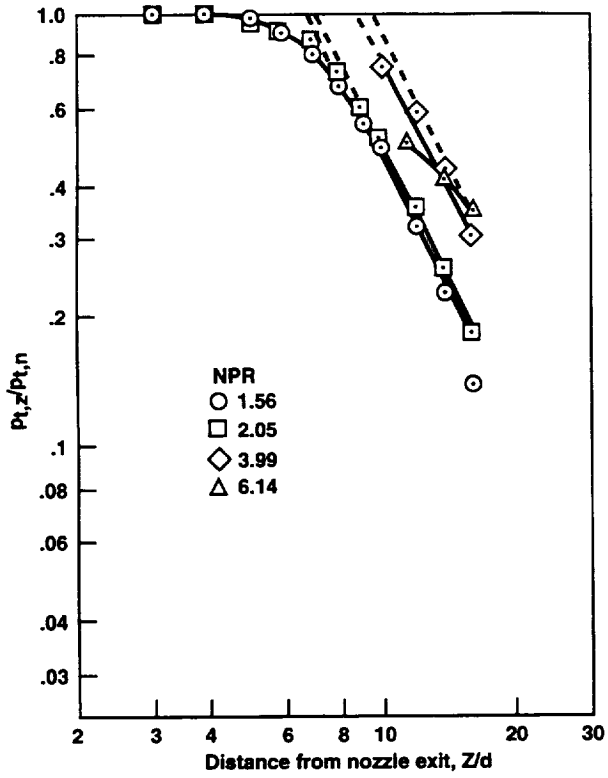
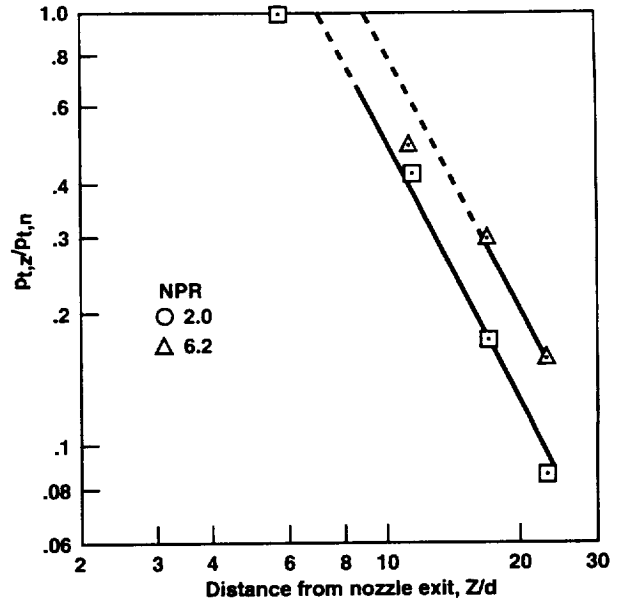

Figure 35. Jet-decay curves for the forward rectangular jet (type 6).



(a) 1.2-in.-diameter circular nozzle (from fig. 17).



(c) 0.87-in.-diameter circular nozzle (from fig. 22(a, b)).

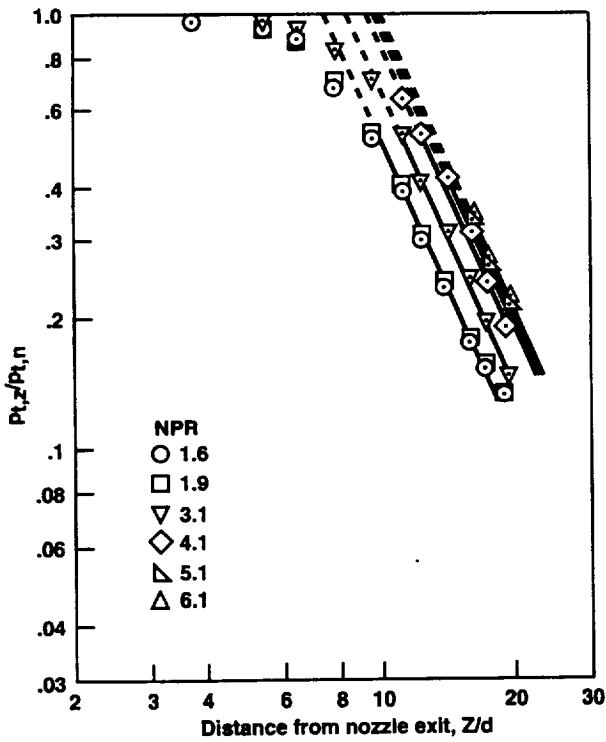

(b) 1.23-in.-diameter circular nozzle.

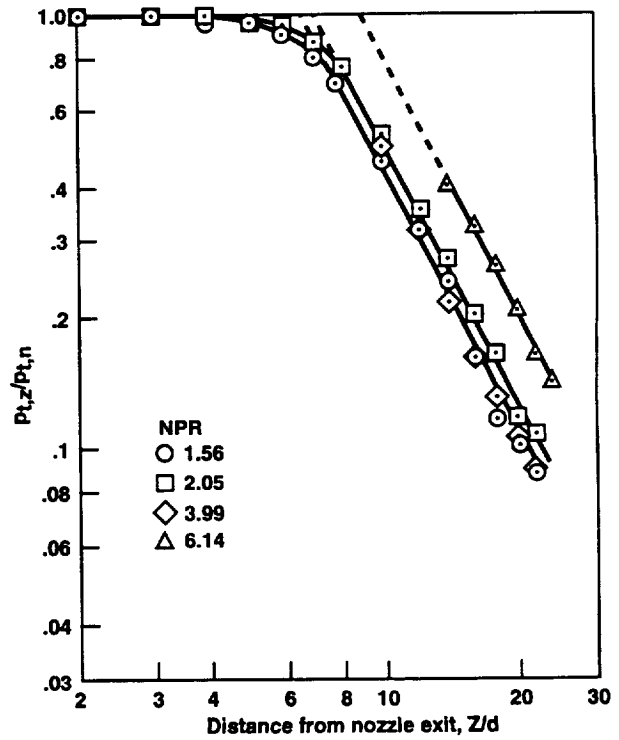

(d) 0.85-in.-diameter circular nozzle (from fig. 28).

Figure 36. Log-log plots of jet decay curves.

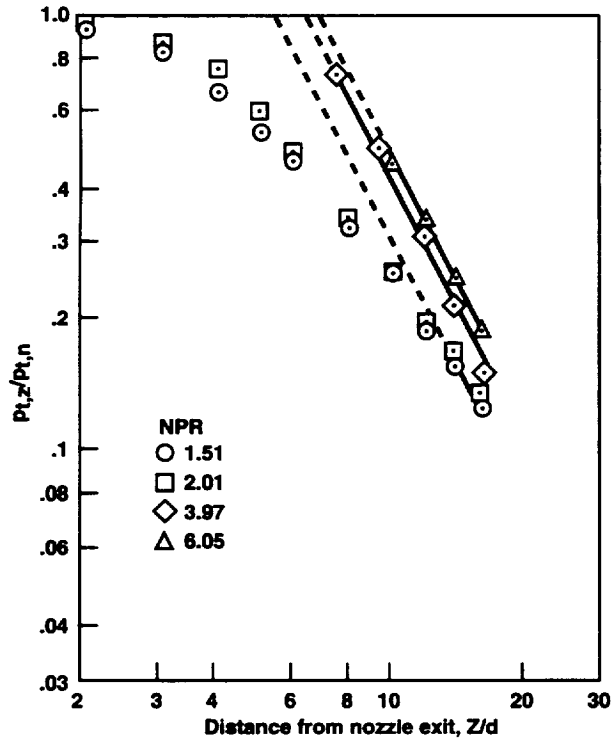
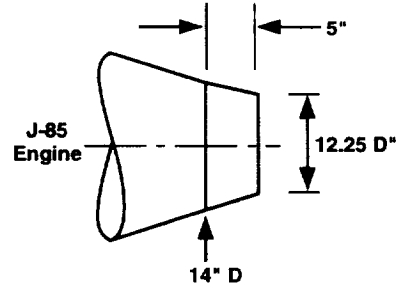

(e) Rectangular nozzle (from fig. 35).

Figure 36. Concluded.

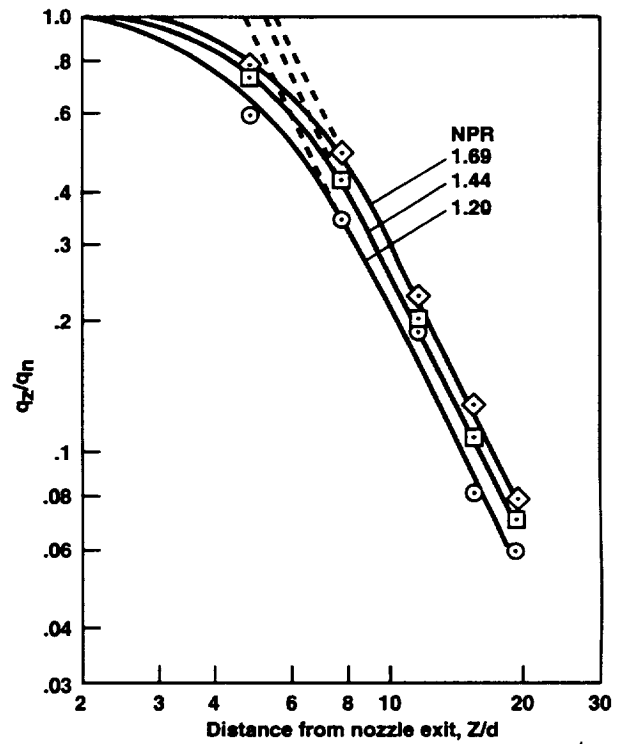

(a) Short nozzle.

Figure 37. Decay curves for a J-85 engine (ref. 6).



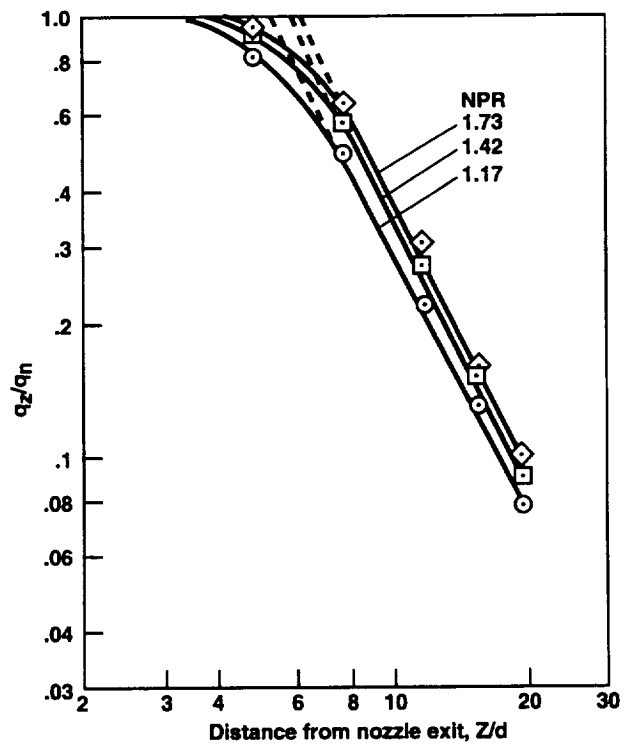
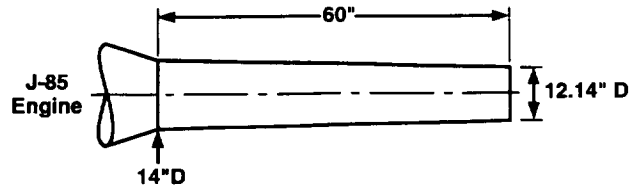

(b) Long nozzle.

Figure 37. Continued.

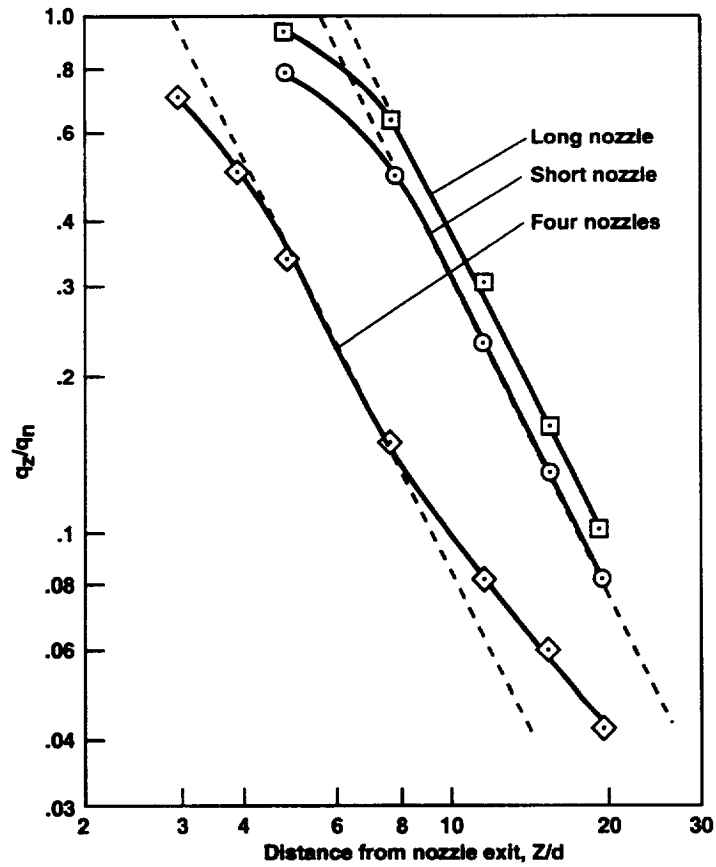
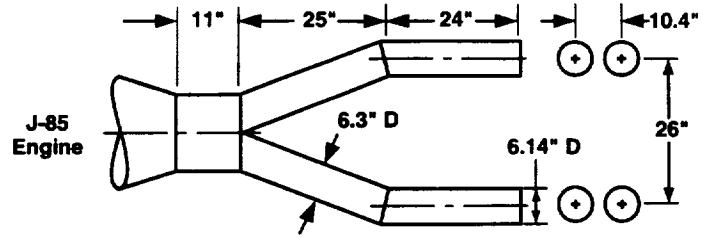

(c) Four-nozzle configuration.

Figure 37. Concluded.

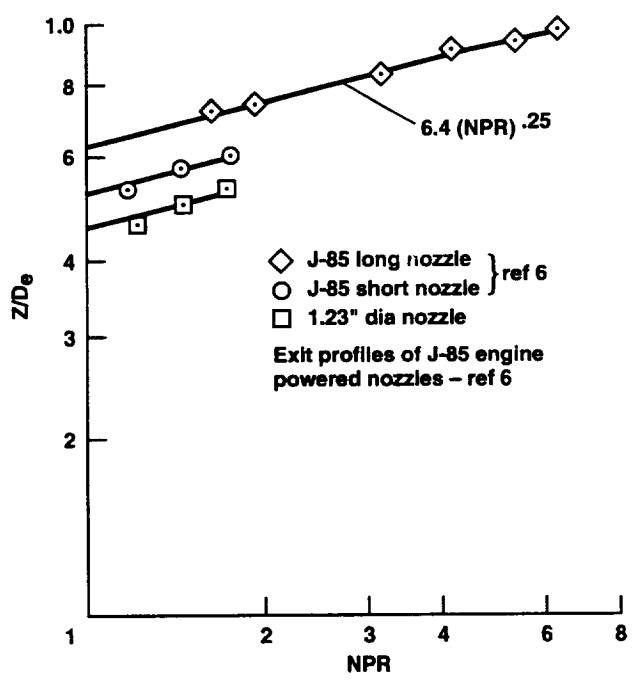
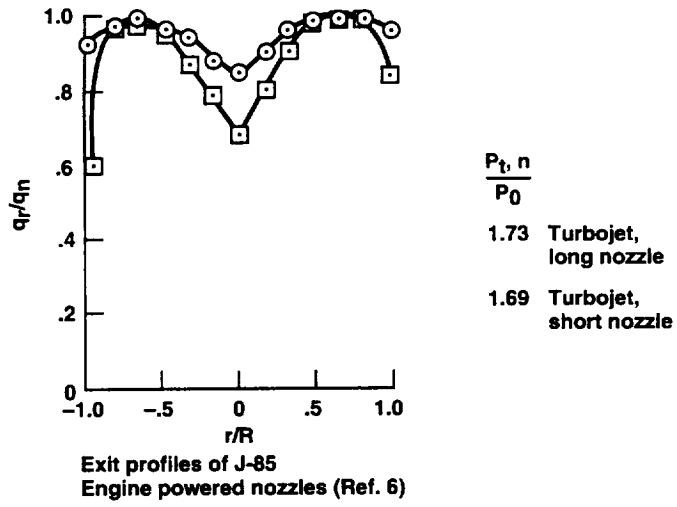

(a) Comparison of a jet engine and a small cold-air jet.

Figure 38. Effect of nozzle configuration and nozzle pressure ratio (NPR) on "effective" core length.

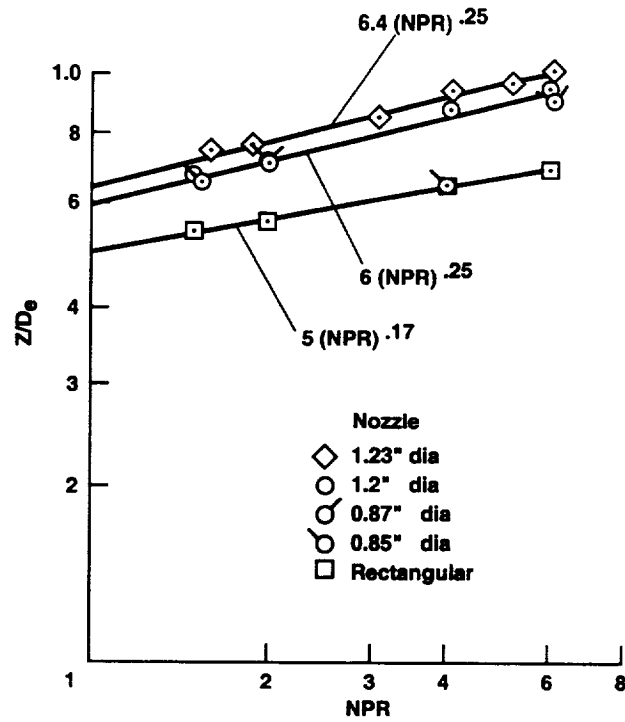

(b) Circular and rectangular cold-air jets.

Figure 38. Concluded.

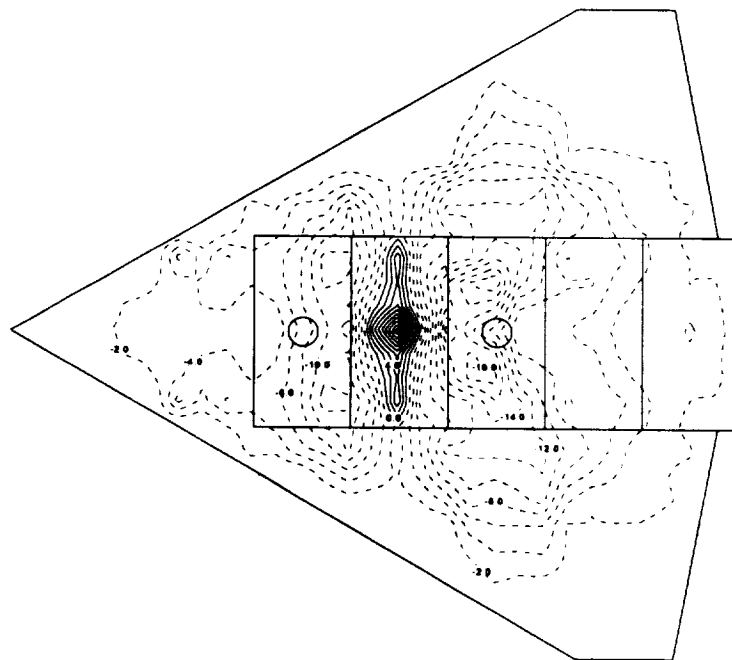

(a) 8-in.-jet spacing (R187P7),  $c_{pmax} = 0.0188$ ,  $c_{pmin} = -0.0260$ .

Figure 39. Contours of  $c_p * 1000$  induced on the model undersurface for a two-jet delta-wing configuration showing the effect of jet spacing. Nozzle pressure ratio (NPR) = 2,  $h/D_0 = 2.36$  ( $h = 4$  in.).

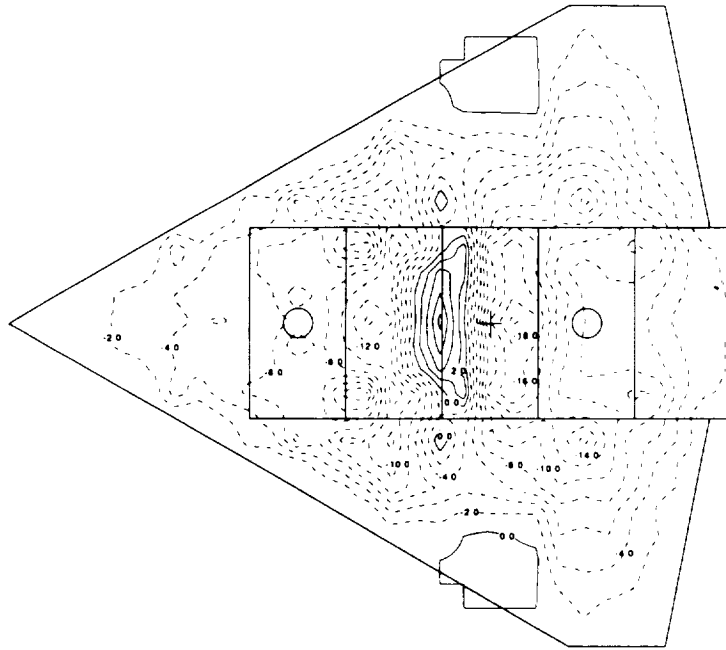

(b) 12-in.-jet spacing (R199P7),  $c_{pmax} = 0.0121$ ,  $c_{pmin} = -0.0227$ .

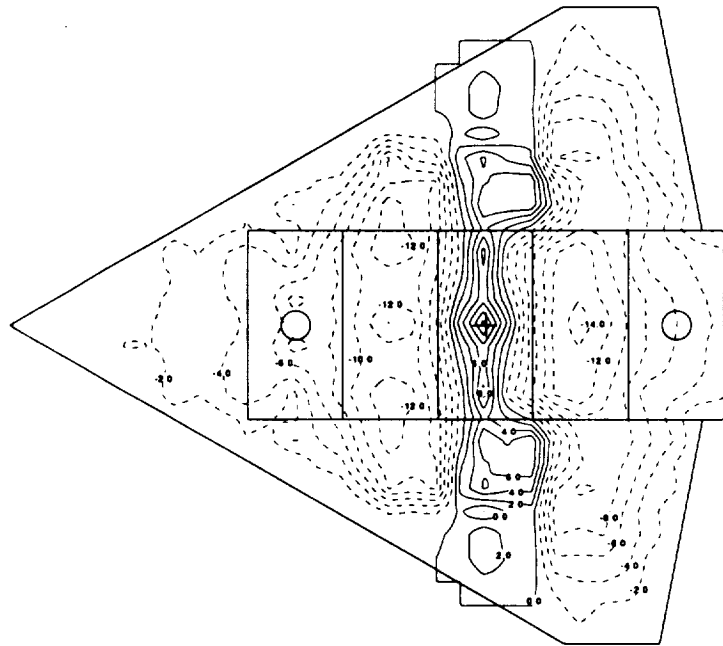

(c) 16-in.-jet spacing (R235P7),  $c_{pmax} = 0.0126$ ,  $c_{pmin} = -0.0151$ .

Figure 39. Concluded.

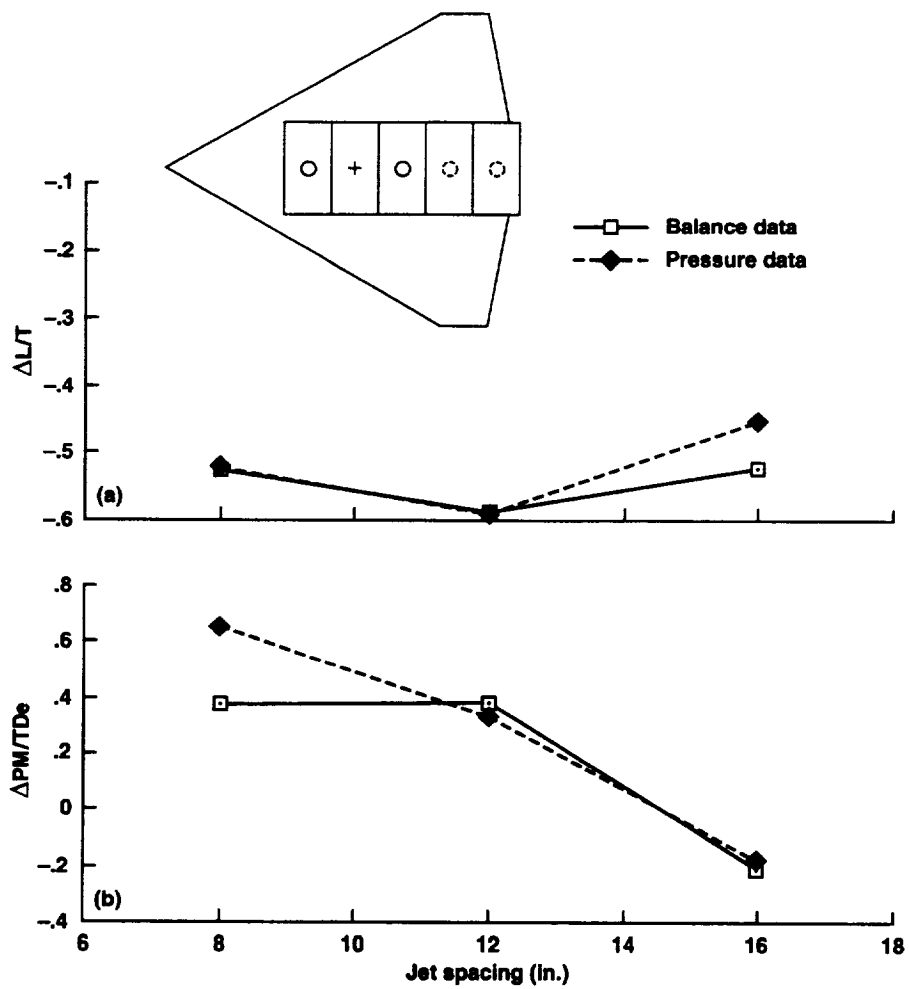
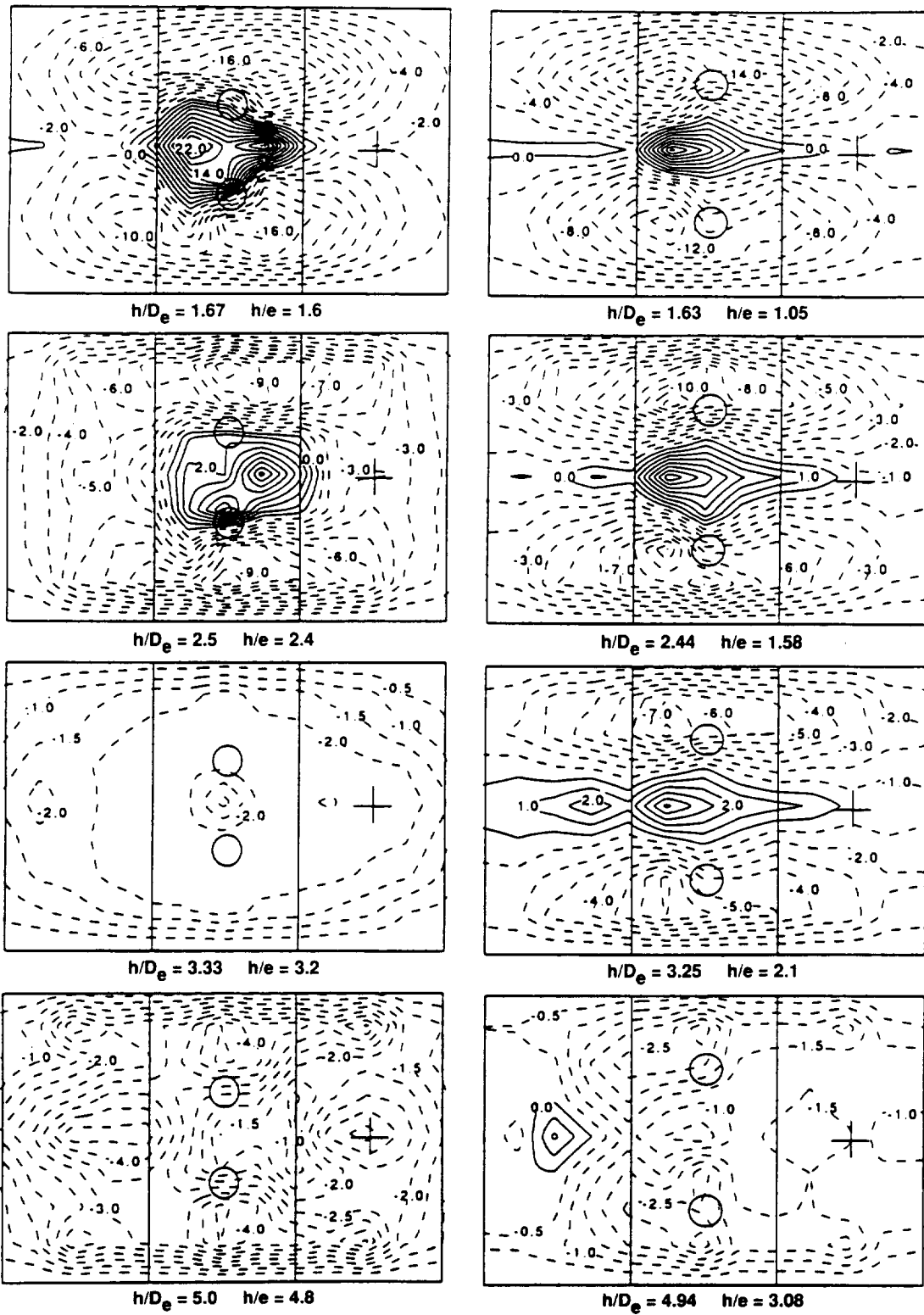

Figure 40. Balance and pressure data comparing jet spacing two-jet delta-wing configuration. Forward jet at the same location,  $h/D_e = 2.36$  ( $h = 4$  in.). Nozzle pressure ratio (NPR) = 2. (a) Jet-induced lift increments, (b) jet-induced pitching moment increments.



(a) 2C\_0\_2.5\_12/8.

(b) 2C\_0\_3.9\_12/8.

Figure 41. Contours of  $c_p \cdot 1000$  induced on the model undersurface by two closely spaced jets. Nozzle pressure ratio (NPR) = 2.

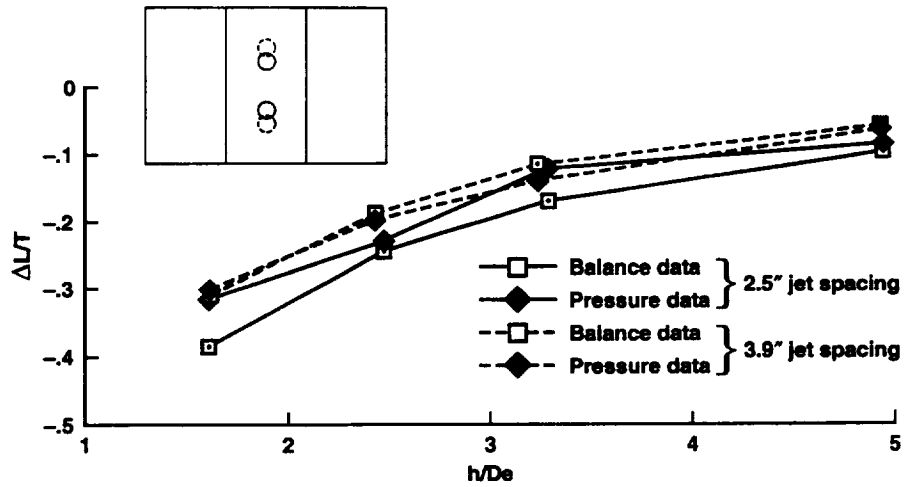

Figure 42. Balance and pressure data comparing the 2.5 in. and 3.9 in. jet spacing for the 12/8 aspect-ratio platform. Nozzle pressure ratio (NPR) = 2.

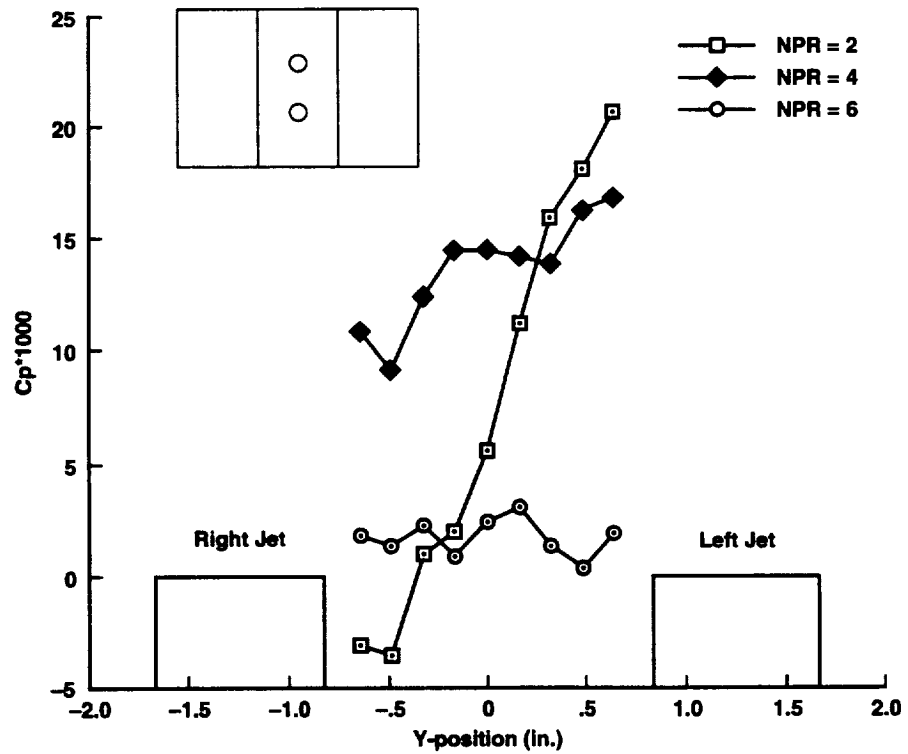

Figure 43. Pressure coefficients between the side-by-side nozzles ( $X = 0$  in.) for the 2C\_0\_2.5\_12/8 configuration at nozzle pressure ratio (NPR) = 2, 4, and 6.



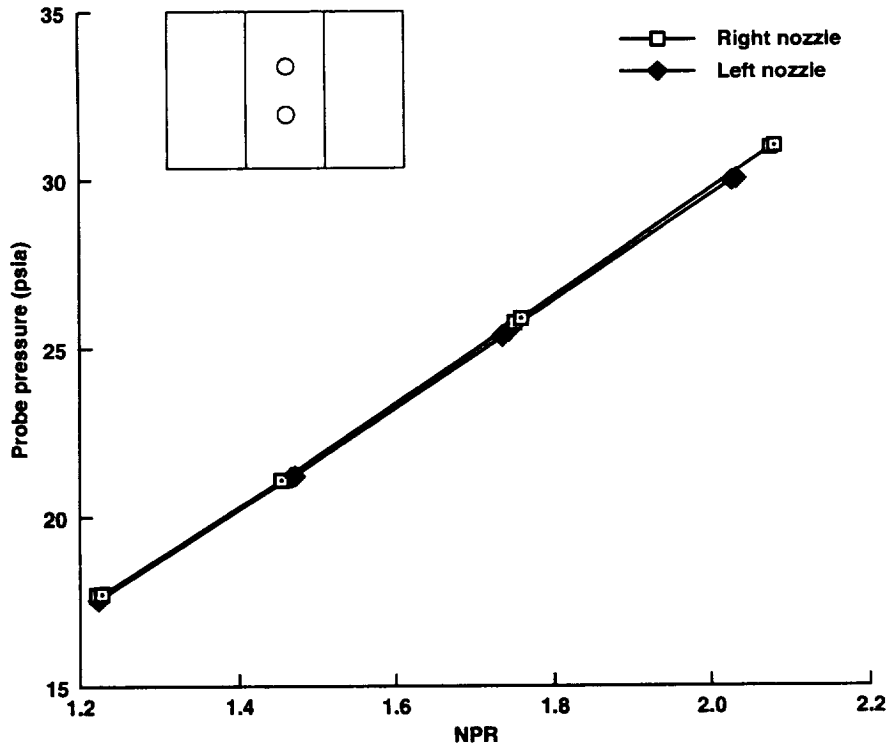
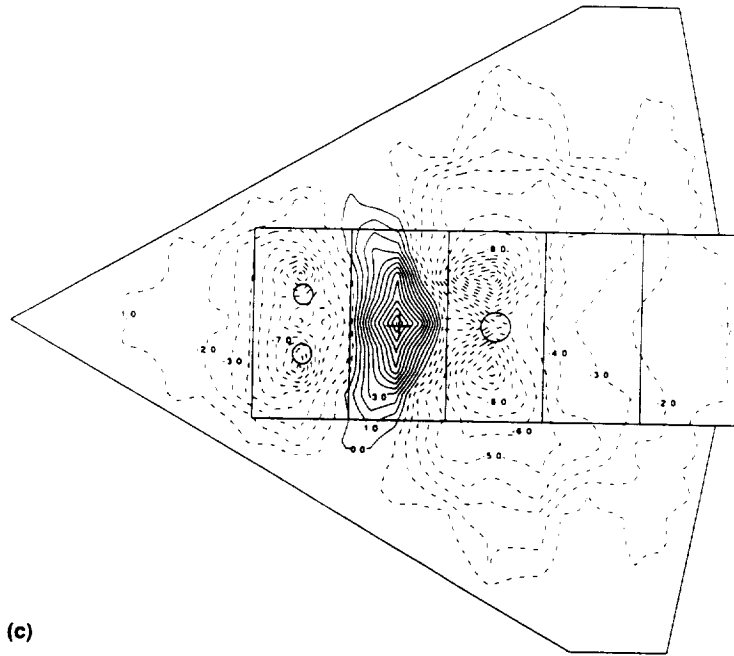
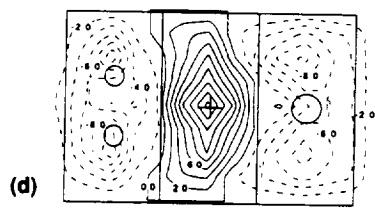

Figure 44. Comparison of nozzle exit pressure for the right and left nozzles of the 2C\_0\_2.5\_12/8 configuration.





(c)



(d)

Figure 45. Continued. (c) 3C\_8\_2.5\_DW (R260P7),  $h/D_e = 3.53$  ( $h = 6$  in.),  $c_{pmax} = 0.0121$ ,  $c_{pmin} = -0.0191$ ,  
 (d) 3C\_8\_2.5\_12/8 (R268P9),  $h/D_e = 3.53$  ( $h = 6$  in.),  $c_{pmax} = 0.0168$ ,  $c_{pmin} = -0.0245$ .

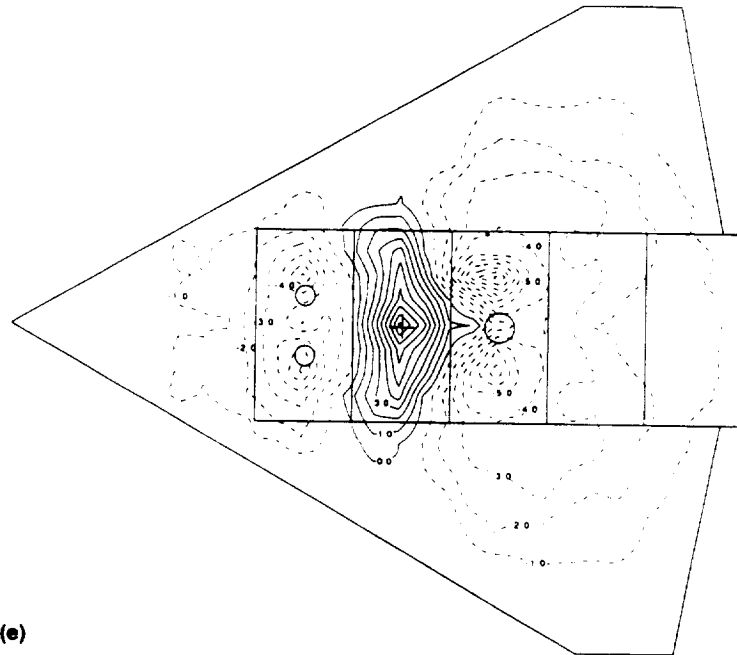

(e)

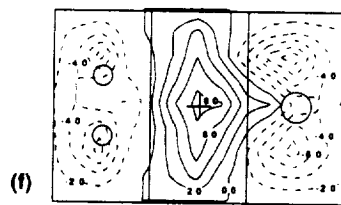

(f)

Figure 45. Continued. (e) 3C\_8\_2.5\_DW (R260P6),  $h/D_e = 4.71$  ( $h = 8$  in.),  $c_{pmax} = 0.0093$ ,  $c_{pmin} = -0.0115$ ,  
 (f) 3C\_8\_2.5\_12/8 (R268P5),  $h/D_e = 4.71$  ( $h = 8$  in.),  $c_{pmax} = 0.0098$ ,  $c_{pmin} = -0.0184$ .

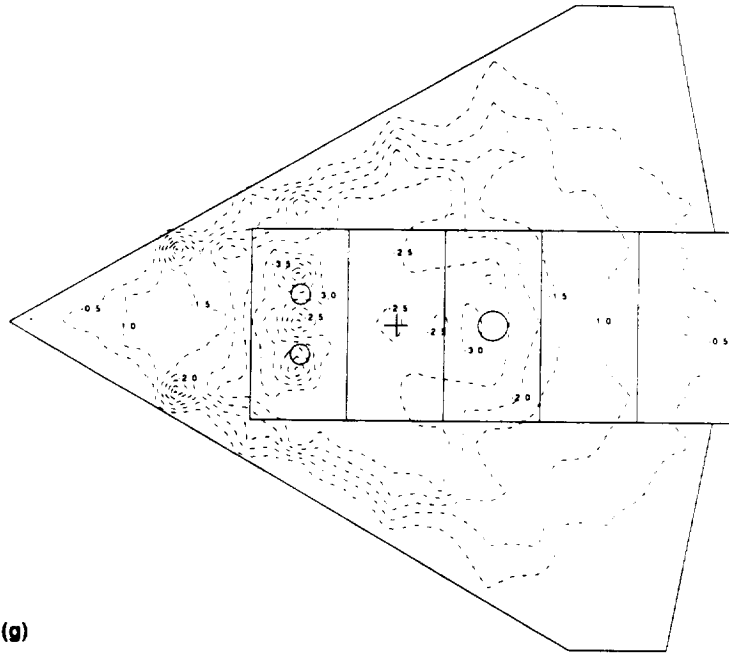

(g)

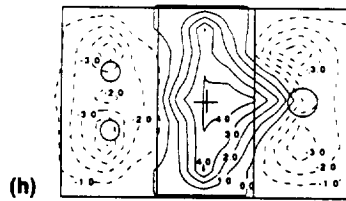

(h)

Figure 45. Concluded. (g) 3C\_8\_2.5\_DW (R260P5),  $h/D_e = 5.89$  ( $h = 10$  in.),  $c_{pmax} = -0.0003$ ,  $c_{pmin} = -0.0065$ ,  
 (h) 3C\_8\_2.5\_12/8 (R268P4),  $h/D_e = 5.89$  ( $h = 10$  in.),  $c_{pmax} = 0.0055$ ,  $c_{pmin} = -0.0116$ .

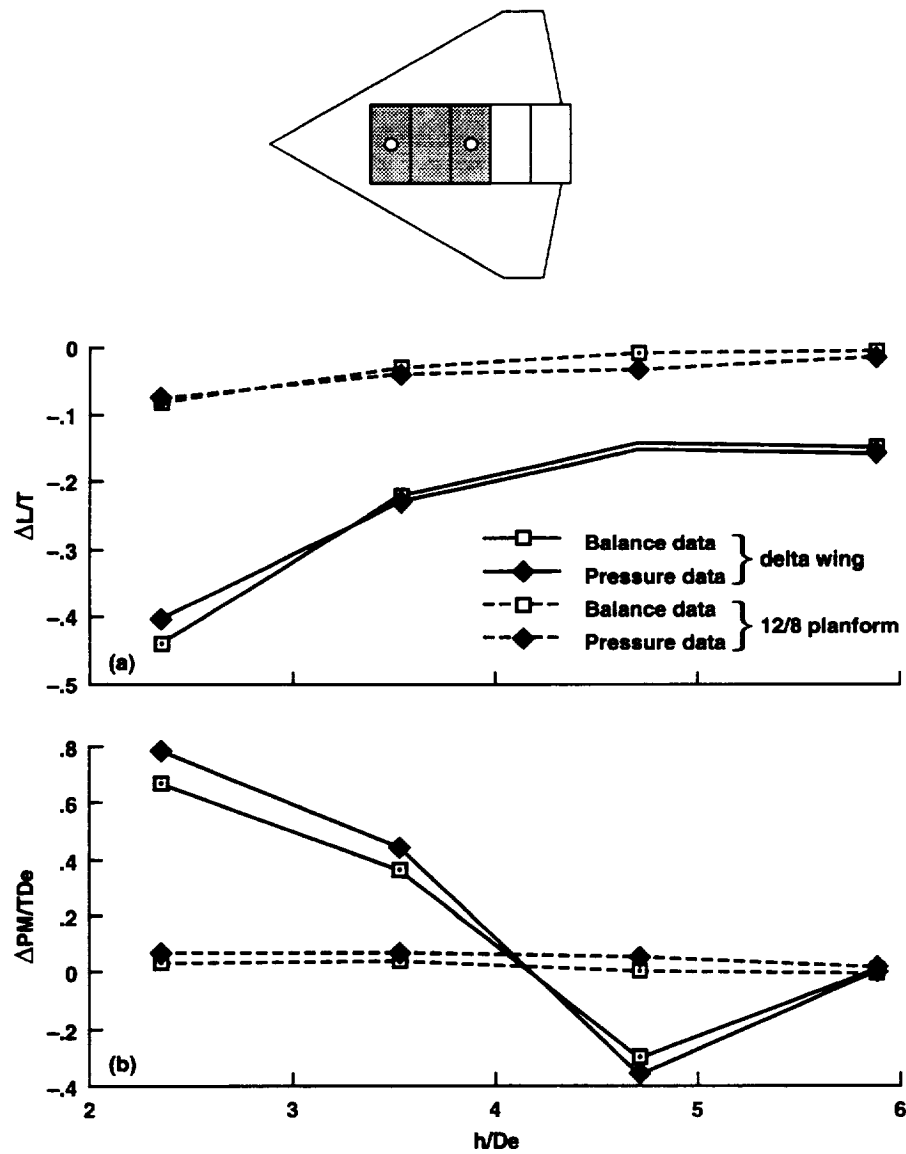

Figure 46. Balance and pressure data comparing planform shape for the three-jet, 8 in. spaced configuration. Nozzle pressure ratio (NPR) = 2. (a) Jet-induced lift increments, (b) jet-induced pitching-moment increments.

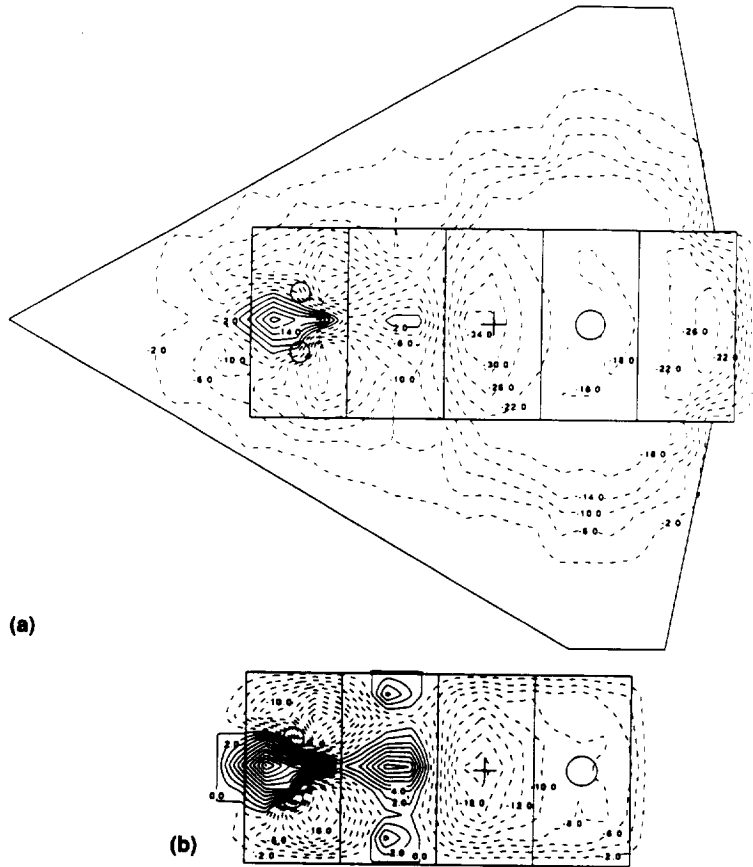
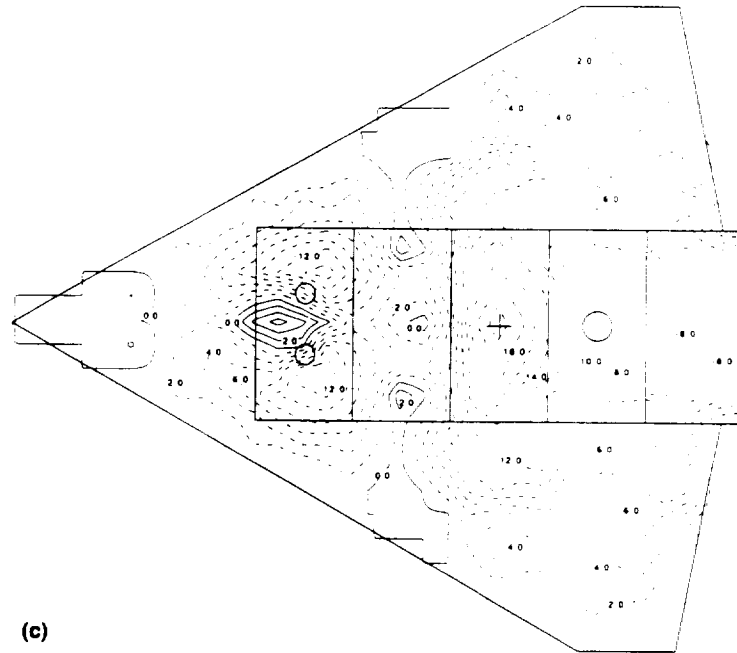
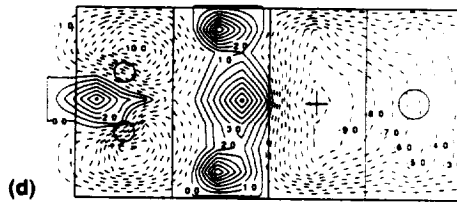

Figure 47. Contours of  $c_p \cdot 1000$  on the model undersurface induced by a 12 in. spaced fore/aft three-jet arrangement for two different planforms. Nozzle pressure ratio (NPR) = 2 on all jets. (a) 3C\_12\_2.5\_DW (R271P10),  $h/D_e = 1.18$  ( $h = 2$  in.),  $c_{pmax} = 0.0571$ ,  $c_{pmin} = -0.0523$ , (b) 3C\_12\_2.5\_16/8 (R274P10),  $h/D_e = 1.18$  ( $h = 2$  in.),  $c_{pmax} = 0.0540$ ,  $c_{pmin} = -0.0400$ .



(c)



(d)

Figure 47. Continued. (c) 3C\_12\_2.5\_DW (R271P9),  $h/D_e = 1.77$  ( $h = 3$  in.),  $c_{pmax} = 0.0149$ ,  $c_{pmin} = -0.0214$ ,  
 (d) 3C\_12\_2.5\_16/8 (R274P9),  $h/D_e = 1.77$  ( $h = 3$  in.),  $c_{pmax} = 0.0130$ ,  $c_{pmin} = -0.0166$ .



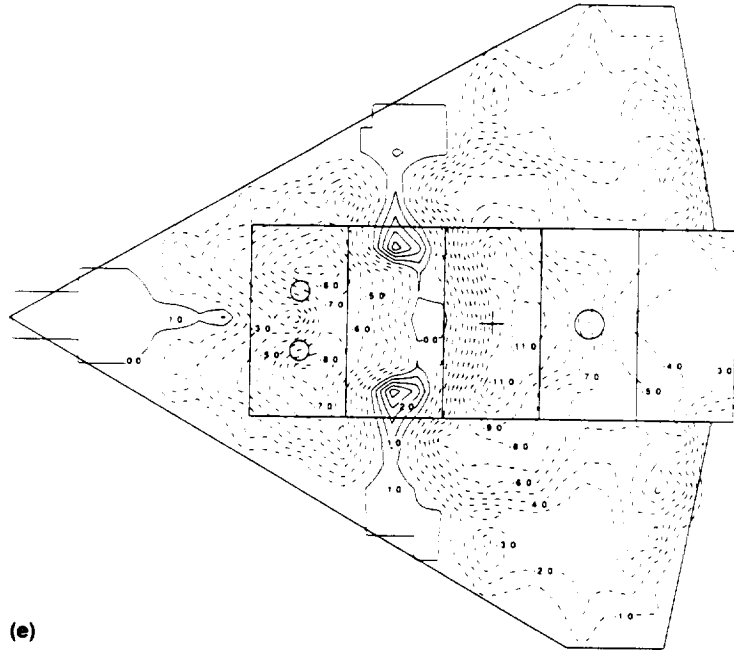

(e)

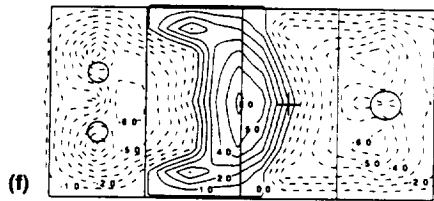

(f)

Figure 47. Continued. (e) 3C\_12\_2.5\_DW (R271P8),  $h/D_e = 2.35$  ( $h = 4$  in.),  $c_{pmax} = 0.0046$ ,  $c_{pmin} = -0.0126$ ,  
 (f) 3C\_12\_2.5\_16/8 (R274P8),  $h/D_e = 2.35$  ( $h = 4$  in.),  $c_{pmax} = 0.0079$ ,  $c_{pmin} = -0.0104$ .

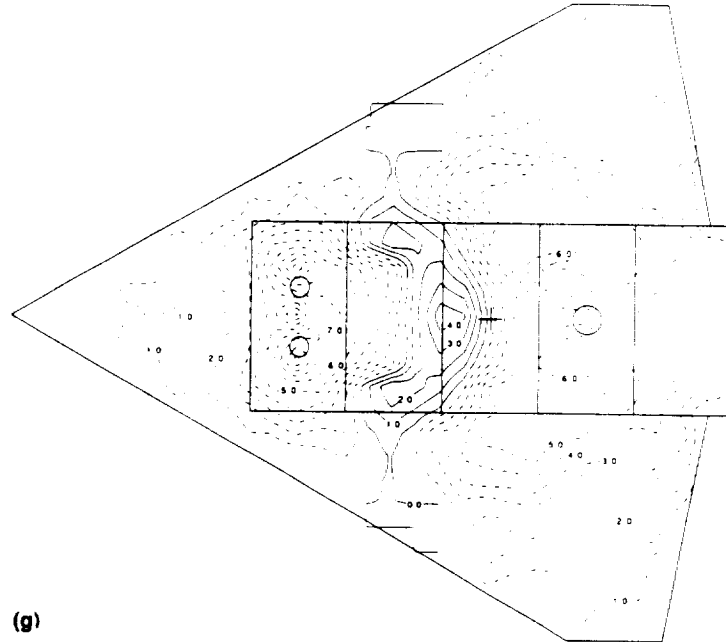

(g)

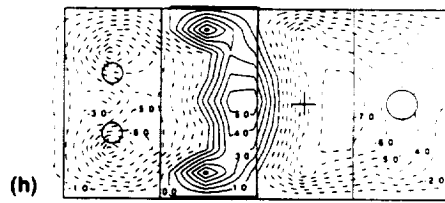

(h)

Figure 47. Continued. (g) 3C\_12\_2.5\_DW (R271P7),  $h/D_e = 3.53$  ( $h = 6$  in.),  $c_{pmax} = 0.0041$ ,  $c_{pmin} = -0.0125$ ,  
 (h) 3C\_12\_2.5\_16/8 (R274P7),  $h/D_e = 3.53$  ( $h = 6$  in.),  $c_{pmax} = 0.0078$ ,  $c_{pmin} = -0.0101$ .

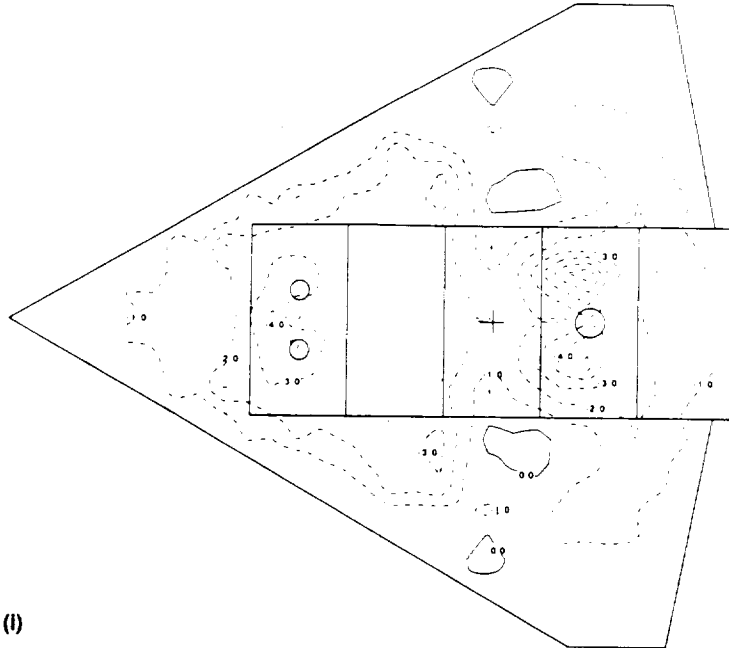

(i)

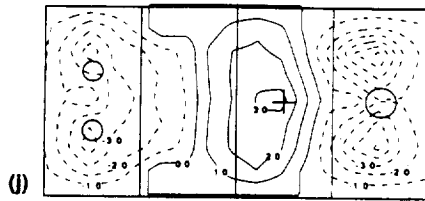

(j)

Figure 47. Concluded. (i) 3C\_12\_2.5\_DW (R271P5),  $h/D_e = 5.89$  ( $h = 10$  in.),  $c_{pmax} = 0.0004$ ,  $c_{pmin} = -0.0094$ ,  
 (j) 3C\_12\_2.5\_16/8 (R274P5),  $h/D_e = 5.89$  ( $h = 10$  in.),  $c_{pmax} = 0.0035$ ,  $c_{pmin} = -0.0092$ .

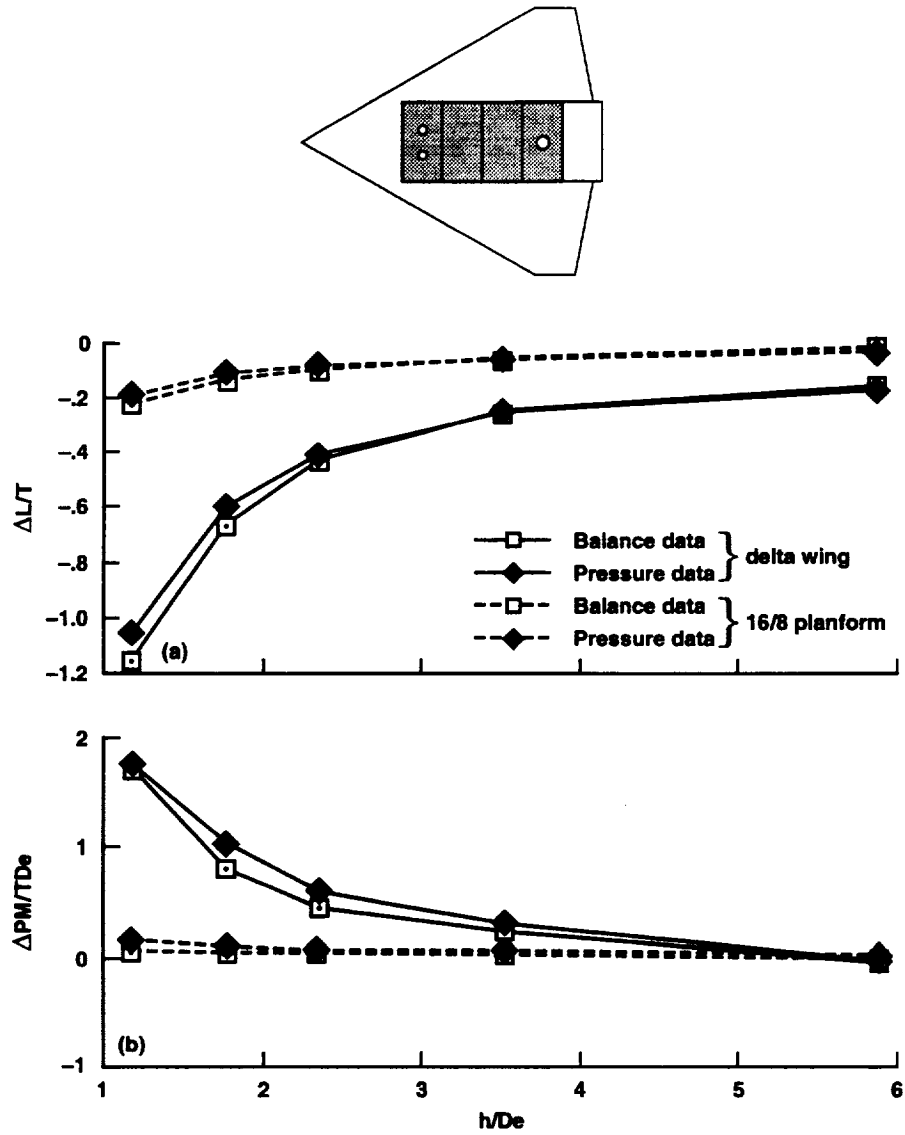

Figure 48. Balance and pressure data comparing planform shape for the three-jet, 12 in. spaced configuration. Nozzle pressure ratio (NPR) = 2. (a) Jet-induced lift increments, (b) jet-induced pitching-moment increments.

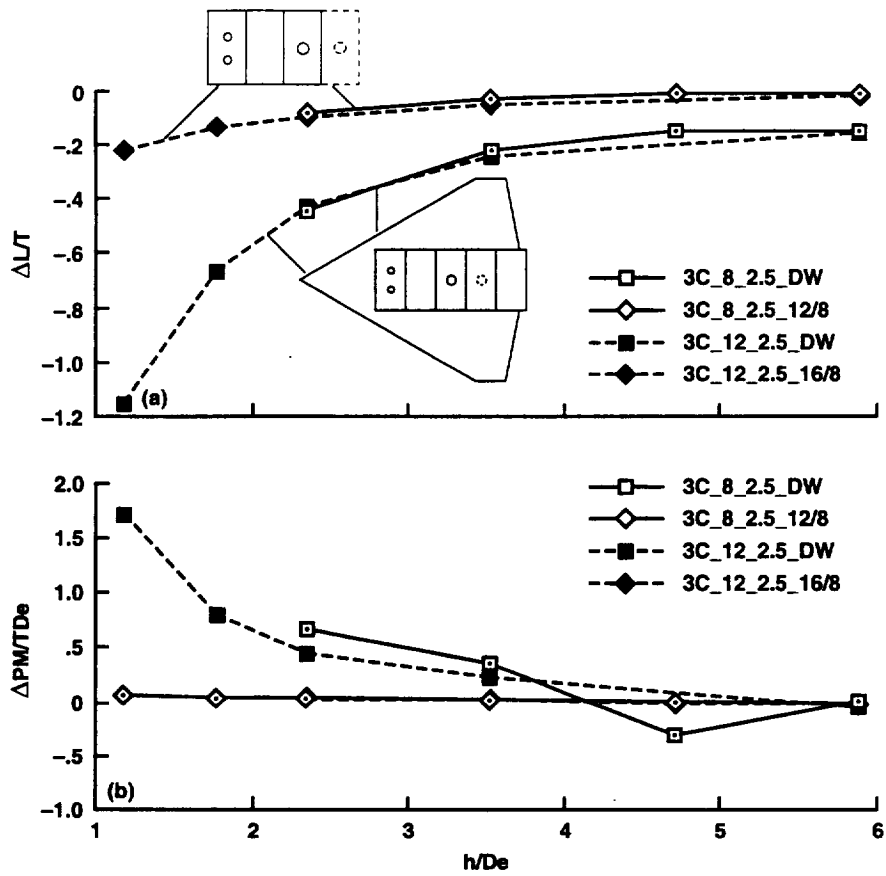
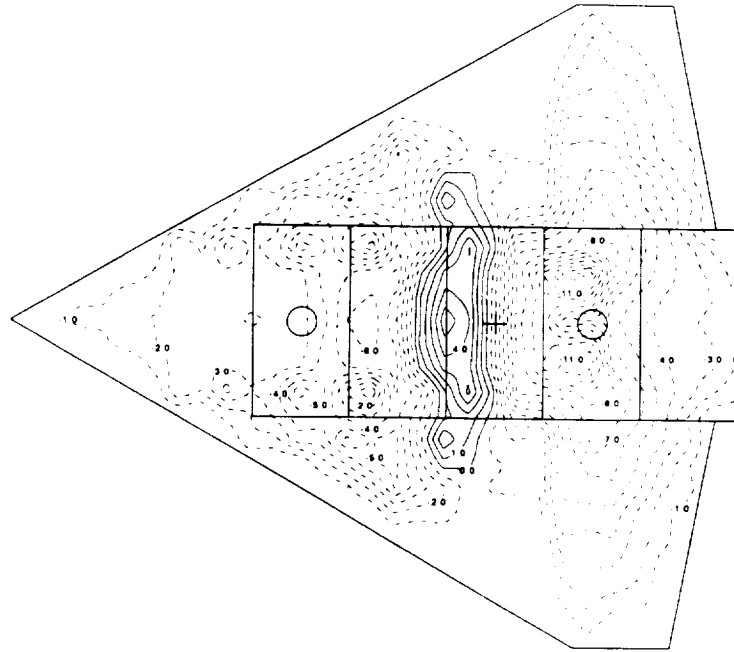
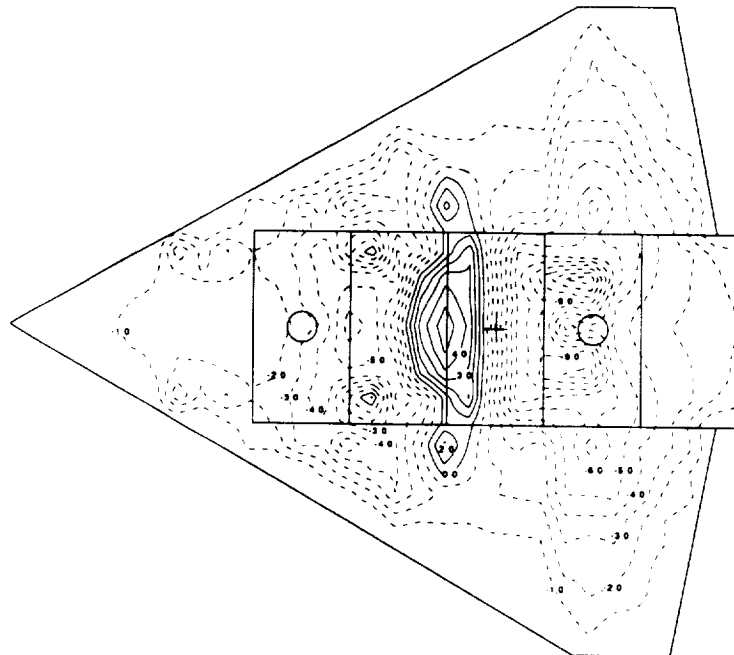

Figure 49. Balance data comparing forward/aft jet spacing and planform geometry. Nozzle pressure ratio (NPR) = 2. (a) Jet-induced lift increments, (b) jet-induced pitching-moment increments.



(a) Nozzle pressure ratio (NPR) = 2 (R199P6),  $c_{pmax} = 0.0085$ ,  $c_{pmin} = -0.0180$ .



(b) Nozzle pressure ratio (NPR) = 4 (R200P6),  $c_{pmax} = 0.0076$ ,  $c_{pmin} = -0.0161$ .

Figure 50. Contours of  $c_p \cdot 1000$  induced on the model underside for a two-jet delta-wing configuration showing the effect of nozzle pressure ratio (NPR). 12 in. jet spacing,  $h/D_e = 3.54$  ( $h = 6$  in.).

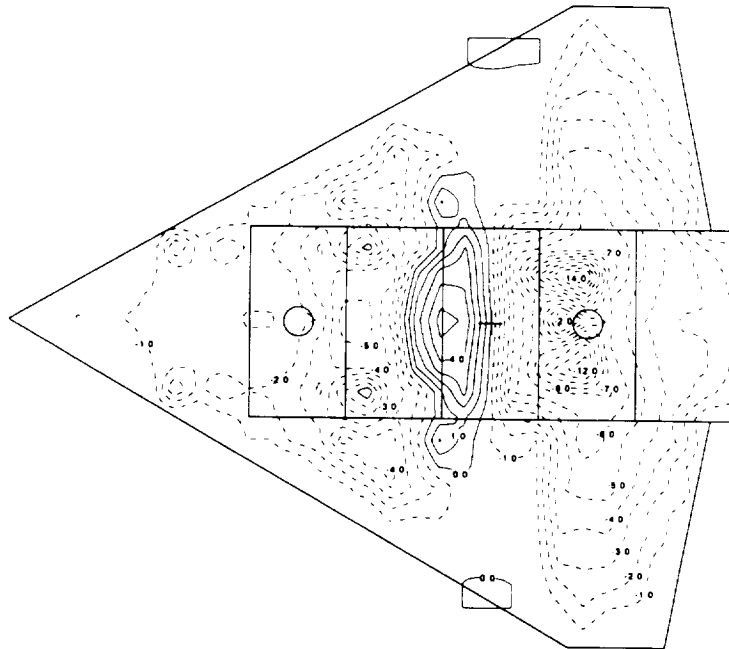

(c) Nozzle pressure ratio (NPR) = 6 (R201P6),  $c_{pmax} = 0.0073$ ,  $c_{pmin} = -0.0197$ .

Figure 50. Concluded.

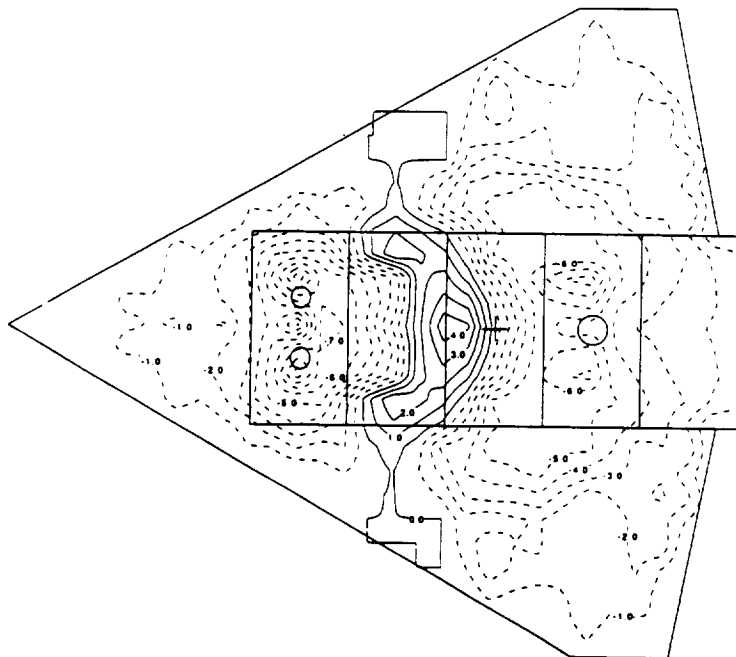

(a) Nozzle pressure ratio (NPR) = 2 (R271P7),  $c_{pmax} = 0.0075$ ,  $c_{pmin} = -0.0125$ .

Figure 51. Contours of  $c_p \cdot 1000$  induced on the model underside for a three-jet delta-wing configuration showing the effect of nozzle pressure ratio (NPR). 12 in. forward/aft jet spacing,  $h/D_e = 3.53$  ( $h = 6$  in.).

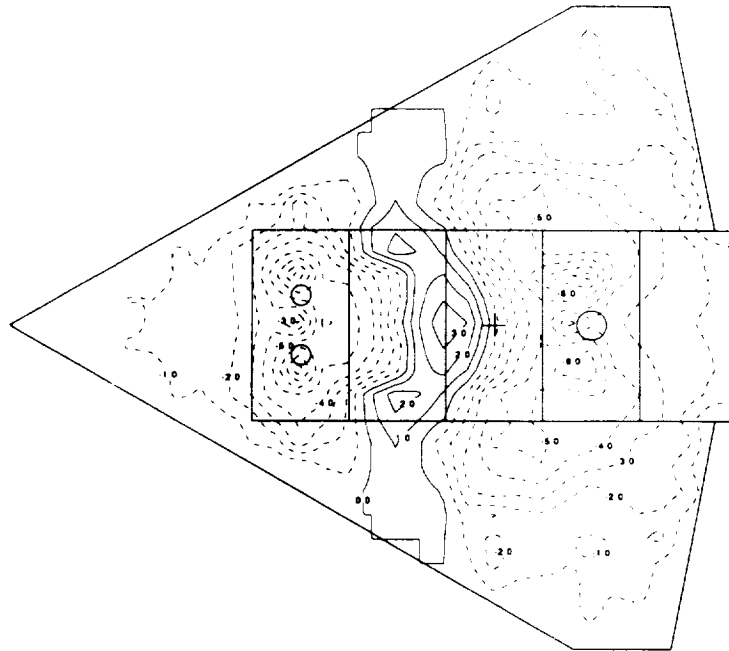

(b) Nozzle pressure ratio (NPR) = 4 (R272P7),  $c_{pmax} = 0.0047$ ,  $c_{pmin} = -0.0127$ .

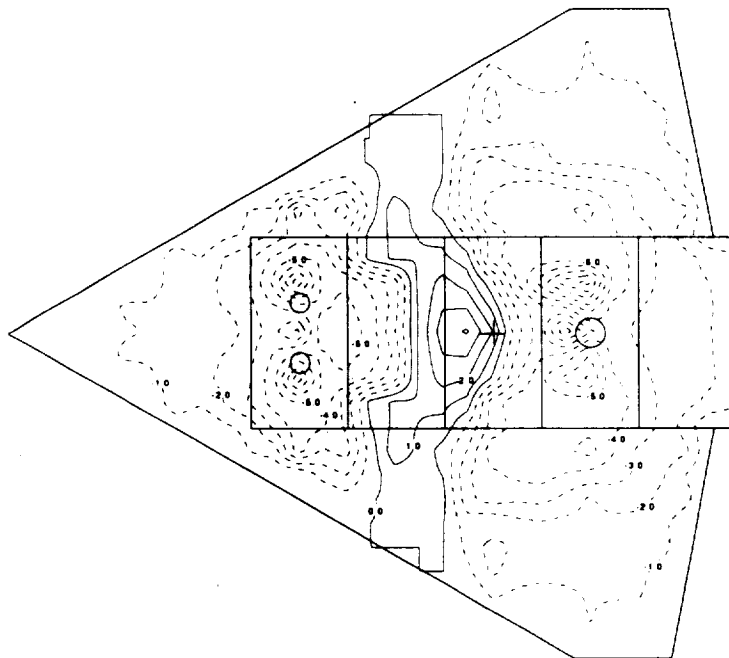

(c) Nozzle pressure ratio (NPR) = 6 (R273P6),  $c_{pmax} = 0.0044$ ,  $c_{pmin} = -0.0118$ .

Figure 51. Concluded.



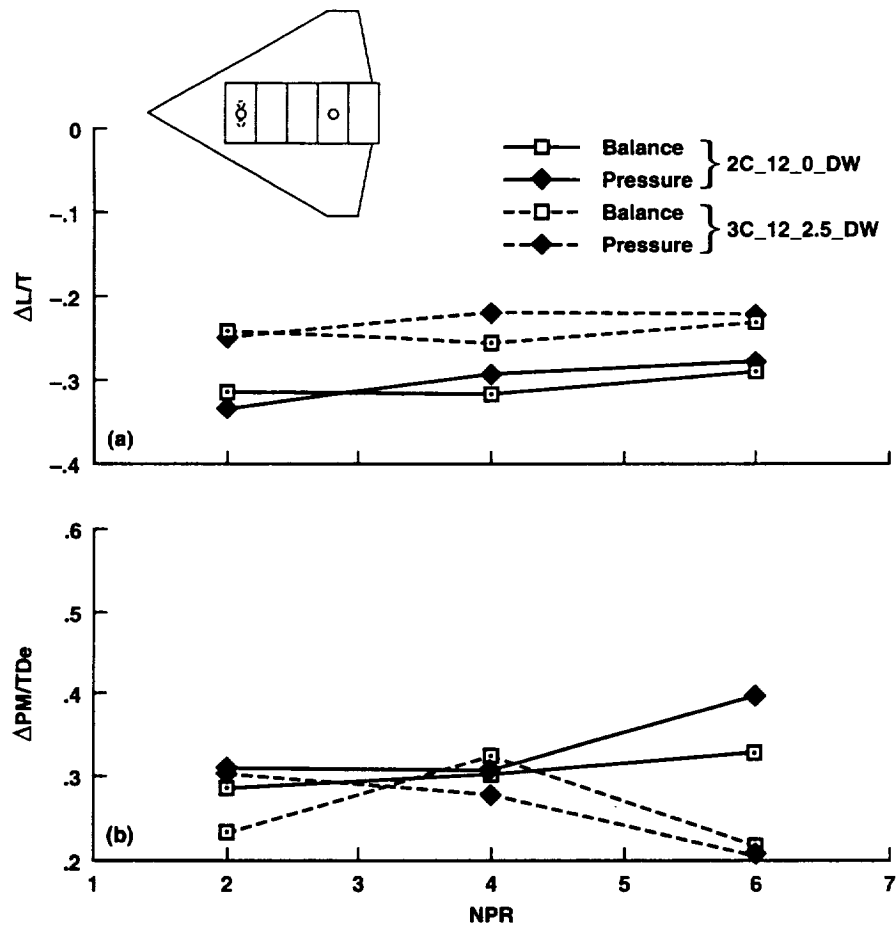

Figure 52. Balance and pressure data as a function of nozzle pressure ratio (NPR) for the 2C\_12\_0\_DW and 3C\_12\_2.5\_DW configurations;  $h/D_e = 3.53$  ( $h = 6$  in.). (a) Jet-induced lift increments, (b) jet-induced pitching-moment increments.



## Appendix

Force and pressure data for each of the 31 configurations tested, including an extra pressure layout for the 2C\_16\_0\_12/24 configuration (designated with an "X" at the end of the name), are grouped by configuration and are contained in this section. The configurations are presented in the order tested. Each data set (group) for a configuration has three parts. First is a 1:4 scale drawing of that configuration with pressure-tap locations shown (dots representing pressure taps show location only and do not represent their actual size). Second is a table listing each pressure-tap X and Y location, associated areas, and moment arms of those areas (for integration) for each configuration. Third are listings of pressure and balance data for each configuration. Port numbers 92 and 158

were not installed in the model and do not appear in any of the data or configuration setup listings.

Table 4 lists the run conditions for each of the configurations tested. NPR and height numbers in the table represent target set conditions. The actual test conditions are provided in the data sets located in this appendix. In some cases the forward and aft NPRs were intentionally different in order to obtain some data on how pitch control using nozzle thrust affects jet-induced lift and pitch characteristics. Some single-jet data are provided for the 2C\_8\_0\_DW, 2C\_12\_0\_DW, and 2R\_8\_0\_DW configurations. The rest of the configurations are variations on planform geometry (mainly aspect ratio), nozzle arrangements, and nozzle geometry (circular or rectangular).

**Table 4. Summary of run conditions and related figures**

Configuration	NPR <sub>f</sub>	NPR <sub>a</sub>	Height (in.)	Runs	Figure(s)
2C_8_0_DW	-	2.0	20-4	185	39(a), 40
	-	4.0	30-4	186	
	2.0	2.0	30-4	187	
	4.0	4.0	30-4	188	
	6.0	6.0	30-4	189	
	2.0	2.0	4	190A	
	1.95	2.05	4	190A	
	1.90	2.10	4	190A	
	2.10	1.90	4-10	190B	
	1.90	2.10	10-4	190C	
	1.95	2.05	4-10	190D	
	4.0	4.0	10-4	191, P1-3	
	3.9	4.1	4-10	191, P4-6	
	4.1	3.9	10-4	191, P7-9	
	3.8	4.2	4-10	191, P10-12	
	6.0	6.0	10,6	191B, P13-14	
5.5	6.4	6,10	191B, P15-16		
6.5	5.6	10,6	191B, P17-18		
2C_8_0_12/8	2.0	2.0	30-2	192	
	4.0	4.0	30-3	193	
	6.0	6.0	30-4	194	
2C_8_0_4/8	2.0	2.0	30-4	195	
	4.0	4.0	15-3	196	
2C_8_0_4/24	2.0	2.0	15-2	197	
	4.0	4.0	15-3	198A	
	6.0	6.0	4-10	198B	
2C_12_0_DW	2.0	2.0	30-3	199	39(b), 40, 50(a), 52
	4.0	4.0	30-4	200	50(b), 52
	6.0	6.0	30-5	201	50(c), 52
	1.9	2.15	10-4	202	
	1.78	2.25	10-4	203	
	1.98	2.07	10-4	204	
	3.68	4.4	20-4	205A, P1-6	
	4.0	4.0	15	205A, P7	
	5.67	6.45	10-5	205B	
	-	2.0	30-4	206	
	-	4.0	30-6	207	
	-	6.0	30-6	208	
	2.0	2.0	30-4	209	
2C_12_0_16/8	2.0	2.0	15-4	210	
	4.0	4.0	15-4	211	
	6.0	6.0	15-4	212	
	2.0	2.0	15-4	213, -4 deg ground plane tilt	
2C_12_0_16/16	2.0	2.0	15-4	214	
	4.0	4.0	4-10	215	

Table 4. Continued

Configuration	NPR <sub>f</sub>	NPR <sub>a</sub>	Height (in.)	Runs	Figure(s)
2C_12_0_16/24	2.0	2.0	30-4	216	
	4.0	4.0	30-4	217	
	6.0	6.0	30-6	218	
2C_12_0_8/24	2.0	2.0	30-4	219	
	4.0	4.0	30-4	220	
	6.0	6.0	30-4	221	
2C_16_0_12/24	2.0	2.0	30-4	222	
2C_16_0_12/24X	2.0	2.0	30-4	223	
	4.0	4.0	30-4	224	
	6.0	6.0	30-5	225	
2C_16_0_4/24	2.0	2.0	30-4	226	
	4.0	4.0	30-4	227	
	6.0	6.0	30-6	228	
2C_16_0_8/24	2.0	2.0	30-4	229	
	4.0	4.0	30-4	230	
	6.0	6.0	15-4	231	
2C_16_0_20/8	2.0	2.0	30-2	232	
	4.0	4.0	30-4	233	
	6.0	6.0	30-4	234	
2C_16_0_DW	2.0	2.0	30-4	235	39(c), 40
	4.0	4.0	30-4	236	
	6.0	6.0	30-6	237	
2R_16_0_DW	2.0	2.0	10,4	238	
	2.0	2.0	30-4	239	
	4.0	4.0	30-4	240	
	6.0	6.0	30-10	241	
	6.0	6.0	30-6	242	
	4.0	4.0	30-4	243	
2R_12_0_DW	2.0	2.0	30-4	244 no ΔPM/TDe data	
	4.0	4.0	4-30	245	
	6.0	6.0	30-6	246, P1-6	
	4.0	4.0	6	246, P7	
	2.0	2.0	6	246, P8	
	2.0	2.0	57.5-4	247	
	4.0	4.0	57.4-4	248	
	1.97	2.19	4-10	249	
	3.76	4.52	4-15	250	
2R_12_0_16/8	2.0	2.0	57.5-2	251	
	4.0	4.0	57.5-4	252	
	6.0	6.0	4-10	253	
2R_8_0_DW	2.0	2.0	57.5-4	254	
	4.0	4.0	20-4	255	
	-	2.0	57.5-4	257	

**Table 4. Concluded**

Configuration	NPR <sub>f</sub>	NPR <sub>a</sub>	Height (in.)	Runs	Figure(s)
2R_8_0_DW	-	4.0	57.5-4	258	
	-	6.0	57.5-4	259	
3C_8_2.5_DW	2.0	2.0	57.5-3	260	45(a)(c)(e)(g), 46, 49
	4.0	4.0	57.5-4	261	
	6.0	6.0	57.5-6	262	
2C_0_2.5_12/8	2.0	-	30-2	263	41, 42, 43
	4.0	-	30-3	264	43
	6.0	-	30-3	265	43
3C_8_2.5_12/8	2.0	2.0	30-2	268	45(b)(d)(f)(h), 46, 49
	4.0	4.0	30-2	269	
	6.0	6.0	30-3	270	
3C_12_2.5_DW	2.0	2.0	57.5-2	271	47(a)(c)(e)(g)(i), 48, 49, 51(a), 52
	4.0	4.0	57.5-3	272	51(b), 52
	6.0	6.0	30-4	273	51(c), 52
3C_12_2.5_16/8	2.0	2.0	57.5-2	274	47(b)(d)(f)(h)(j), 48, 49
	4.0	4.0	30-3	275	
	6.0	6.0	30-3.2	276	
3C_16_2.5_20/8	2.0	2.0	57.5-2	277	
	4.0	4.0	30-3	278	
	6.0	6.0	30-3	279	
4C_16_2.5/3.9_20/8	2	2	57.5-2	280	
	4	4	30-3	281	
	6	6	3-30	282	
4C_12_2.5/3.9_16/8	2	2	57.5-2	283	
	4	4	30-3	284	
	6	6	30-3	285	
4C_8_2.5/3.9_12/8	2	2	57.5-2	286	
	4	4	30-3	287	
	6	6	30-3	288	
2C_0_3.9_12/8	-	2	57.5-2	289	41, 42
	-	4	57.5-3	290	
	-	6	30-3	291	
3C_8_3.9_12/8	2	2	57.5-2	292	
	4	4	30-3	293	
	6	6	30-3	294	
3C_12_3.9_16/8	2	2	57.5-2	295	
	4	4	30-2	296	
	6	6	30-3	297	
3C_16_3.9_20/8	2	2	57.5-2	298	
	4	4	30-2	299	
	6	6	30-3	300	

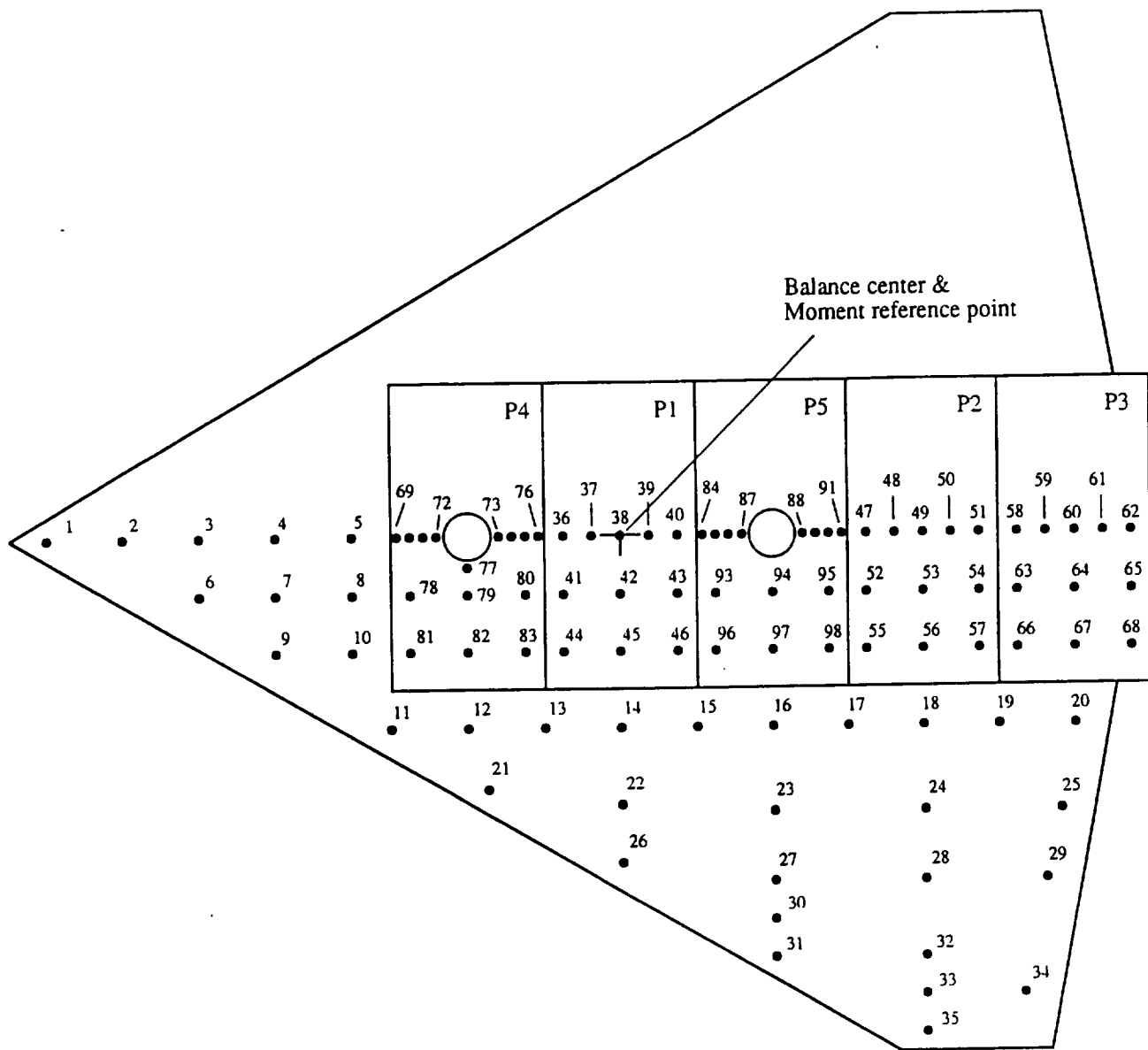

Figure 53. Configuration 2C\_8\_0\_DW;  $D_e = 1.697$  in.,  $A_{jet} = 2.26$  in.<sup>2</sup>.

Pressure Orifice Locations and Weighting Factors

Conf. # 2C\_8\_0\_DW

Distance from balance center to moment reference point,  $X_0 = 0$

Orif. #	Mom. arm	Sta. y	$\Delta$ .Area	Sta. x
1	14.6	0	2.3	15
2	12.86	0	6.918	13
3	11	0	3	11
4	9	0	3	9
5	7	0	3	7
6	10.9	1.5	8.546	11
7	9	1.5	6	9
8	7	1.5	6	7
9	8.87	3	7.166	9
10	7	3	7	7
11	6.14	5	8.91	6
12	4	5	8	4
13	2	5	8	2
14	0	5	8	0
15	-2	5	8	-2
16	-4	5	8	-4
17	-6	5	8	-6
18	-8	5	8	-8
19	-10	5	8	-10
20	-11.91	5	8.06	-12
21	3.06	6.6	7.302	3.5
22	0	7	16	0
23	-4	7	16	-4
24	-8	7	16	-8
25	-11.31	7	10.484	-11.6
26	-0.765	8.5	9.904	0
27	-4	9	12	-4
28	-8	9	16	-8
29	-11.11	9	8.908	-11.2
30	-4	10	8	-4
31	-4.84	11	8.376	-4
32	-8	11	12	-8
33	-8	12	8	-8
34	-10.86	12	12.005	-10.6
35	-8.17	13	6.883	-8
69	5.85	0	0.634	5.85
70	5.5	0	0.683	5.5
71	5.15	0	0.683	5.15
72	4.8	0	0.619	4.8
73	3.2	0	0.619	3.2
74	2.85	0	0.683	2.85
75	2.5	0	0.683	2.5
76	2.15	0	0.634	2.15
77	4	0.8	1.238	4
78	5.5	1.5	3.19	5.5
79	4	1.5	3.825	4



Conf. # 2C\_8\_0\_DW, continued

Orif. #	Mom. arm	Sta. y	Δ.Area	Sta. x
80	2.5	1.5	3.19	2.5
81	5.5	3	4.375	5.5
82	4	3	5.25	4
83	2.5	3	4.375	2.5
36	1.5	0	1.313	1.5
37	0.75	0	1.125	0.75
38	0	0	1.125	0
39	-0.75	0	1.125	-0.75
40	-1.5	0	1.313	-1.5
41	1.5	1.5	3.75	1.5
42	0	1.5	4.5	0
43	-1.5	1.5	3.75	-1.5
44	1.5	3	4.375	1.5
45	0	3	5.25	0
46	-1.5	3	4.375	-1.5
84	-2.15	0	0.634	-2.15
85	-2.5	0	0.683	-2.5
86	-2.85	0	0.683	-2.85
87	-3.2	0	0.619	-3.2
88	-4.8	0	0.619	-4.8
89	-5.15	0	0.683	-5.15
90	-5.5	0	0.683	-5.5
91	-5.85	0	0.634	-5.85
93	-2.5	1.5	3.19	-2.5
94	-4	1.5	5.062	-4
95	-5.5	1.5	3.19	-5.5
96	-2.5	3	4.375	-2.5
97	-4	3	5.25	-4
98	-5.5	3	4.375	-5.5
47	-6.5	0	1.313	-6.5
48	-7.25	0	1.125	-7.25
49	-8	0	1.125	-8
50	-8.75	0	1.125	-8.75
51	-9.5	0	1.313	-9.5
52	-6.5	1.5	3.75	-6.5
53	-8	1.5	4.5	-8
54	-9.5	1.5	3.75	-9.5
55	-6.5	3	4.375	-6.5
56	-8	3	5.25	-8
57	-9.5	3	4.375	-9.5
58	-10.5	0	1.313	-10.5
59	-11.25	0	1.125	-11.25
60	-12	0	1.125	-12
61	-12.75	0	1.125	-12.75
62	-13.5	0	1.313	-13.5
63	-10.5	1.5	3.75	-10.5
64	-12	1.5	4.5	-12
65	-13.5	1.5	3.75	-13.5
66	-10.5	3	4.375	-10.5
67	-12	3	5.25	-12
68	-13.5	3	4.375	-13.5

Configuration: 2C-8-0-DW Jet-Induced Pressure Increments Run 185

Point	3	4	5	6	7	8	
h/De =	16.84	12.62	8.40	6.77	5.07	3.42	
Total Thrust =	26.40	26.52	26.45	26.40	26.72	26.63	
NPR Front =	1.00	1.00	1.00	1.00	1.00	1.00	
NPR Aft =	2.01	2.02	2.01	2.03	2.03	2.02	
X-loc	ACP	ACP	ACP	ACP	ACP	ACP	
Y-loc	ACP	ACP	ACP	ACP	ACP	ACP	
15.00	0.00	-0.001127	-0.002029	-0.003361	-0.005356	-0.008319	-0.000078
13.00	0.00	-0.000239	-0.000306	-0.000444	-0.000539	-0.000594	-0.000872
11.00	0.00	-0.000200	-0.000267	-0.000424	-0.000559	-0.000671	-0.001172
9.00	0.00	-0.000200	-0.000234	-0.000404	-0.000564	-0.000831	-0.001840
7.00	0.00	-0.000200	-0.000234	-0.000404	-0.000564	-0.000831	-0.001840
5.85	0.00	-0.000084	-0.000141	-0.000239	-0.000360	-0.000514	-0.000748
5.50	0.00	-0.000071	-0.000119	-0.000216	-0.000336	-0.000490	-0.000728
5.15	0.00	-0.000071	-0.000119	-0.000216	-0.000336	-0.000490	-0.000728
4.80	0.00	-0.000071	-0.000119	-0.000216	-0.000336	-0.000490	-0.000728
4.45	0.00	-0.000104	-0.000179	-0.000275	-0.000424	-0.000600	-0.000831
4.10	0.00	-0.000104	-0.000179	-0.000275	-0.000424	-0.000600	-0.000831
3.75	0.00	-0.000092	-0.000145	-0.000239	-0.000360	-0.000514	-0.000748
3.40	0.00	-0.000088	-0.000141	-0.000234	-0.000336	-0.000490	-0.000728
3.05	0.00	-0.000088	-0.000141	-0.000234	-0.000336	-0.000490	-0.000728
2.70	0.00	-0.000088	-0.000141	-0.000234	-0.000336	-0.000490	-0.000728
2.35	0.00	-0.000088	-0.000141	-0.000234	-0.000336	-0.000490	-0.000728
2.00	0.00	-0.000088	-0.000141	-0.000234	-0.000336	-0.000490	-0.000728
1.65	0.00	-0.000088	-0.000141	-0.000234	-0.000336	-0.000490	-0.000728
1.30	0.00	-0.000088	-0.000141	-0.000234	-0.000336	-0.000490	-0.000728
0.95	0.00	-0.000088	-0.000141	-0.000234	-0.000336	-0.000490	-0.000728
0.60	0.00	-0.000088	-0.000141	-0.000234	-0.000336	-0.000490	-0.000728
0.25	0.00	-0.000088	-0.000141	-0.000234	-0.000336	-0.000490	-0.000728
0.00	0.00	-0.000088	-0.000141	-0.000234	-0.000336	-0.000490	-0.000728
-0.35	0.00	-0.000202	-0.000372	-0.000542	-0.000712	-0.000882	-0.001052
-0.70	0.00	-0.000266	-0.000441	-0.000611	-0.000781	-0.000951	-0.001122
-1.05	0.00	-0.000330	-0.000500	-0.000670	-0.000840	-0.001010	-0.001180
-1.40	0.00	-0.000394	-0.000564	-0.000734	-0.000904	-0.001074	-0.001244
-1.75	0.00	-0.000458	-0.000628	-0.000798	-0.000968	-0.001138	-0.001308
-2.10	0.00	-0.000522	-0.000692	-0.000862	-0.001032	-0.001202	-0.001362
-2.45	0.00	-0.000586	-0.000756	-0.000926	-0.001096	-0.001266	-0.001426
-2.80	0.00	-0.000650	-0.000820	-0.000990	-0.001160	-0.001330	-0.001490
-3.15	0.00	-0.000714	-0.000884	-0.001054	-0.001224	-0.001394	-0.001554
-3.50	0.00	-0.000778	-0.000948	-0.001118	-0.001288	-0.001458	-0.001618
-3.85	0.00	-0.000842	-0.001012	-0.001182	-0.001352	-0.001522	-0.001682
-4.20	0.00	-0.000906	-0.001076	-0.001246	-0.001416	-0.001586	-0.001746
-4.55	0.00	-0.000970	-0.001140	-0.001310	-0.001480	-0.001650	-0.001810
-4.90	0.00	-0.001034	-0.001204	-0.001374	-0.001544	-0.001714	-0.001874
-5.25	0.00	-0.001098	-0.001268	-0.001438	-0.001608	-0.001778	-0.001938
-5.60	0.00	-0.001162	-0.001332	-0.001502	-0.001672	-0.001842	-0.002002
-5.95	0.00	-0.001226	-0.001396	-0.001566	-0.001736	-0.001906	-0.002066
-6.30	0.00	-0.001290	-0.001460	-0.001630	-0.001800	-0.001970	-0.002130
-6.65	0.00	-0.001354	-0.001524	-0.001694	-0.001864	-0.002034	-0.002194
-7.00	0.00	-0.001418	-0.001588	-0.001758	-0.001928	-0.002098	-0.002258
-7.35	0.00	-0.001482	-0.001652	-0.001822	-0.001992	-0.002162	-0.002322
-7.70	0.00	-0.001546	-0.001716	-0.001886	-0.002056	-0.002226	-0.002386
-8.05	0.00	-0.001610	-0.001780	-0.001950	-0.002120	-0.002290	-0.002450
-8.40	0.00	-0.001674	-0.001844	-0.002014	-0.002184	-0.002354	-0.002514
-8.75	0.00	-0.001738	-0.001908	-0.002078	-0.002248	-0.002418	-0.002578
-9.10	0.00	-0.001802	-0.001972	-0.002142	-0.002312	-0.002482	-0.002642
-9.45	0.00	-0.001866	-0.002036	-0.002206	-0.002376	-0.002546	-0.002706
-9.80	0.00	-0.001930	-0.002100	-0.002270	-0.002440	-0.002610	-0.002770
-10.15	0.00	-0.001994	-0.002164	-0.002334	-0.002504	-0.002674	-0.002834
-10.50	0.00	-0.002058	-0.002228	-0.002398	-0.002568	-0.002738	-0.002898
-10.85	0.00	-0.002122	-0.002292	-0.002462	-0.002632	-0.002802	-0.002962
-11.20	0.00	-0.002186	-0.002356	-0.002526	-0.002696	-0.002866	-0.003026
-11.55	0.00	-0.002250	-0.002420	-0.002590	-0.002760	-0.002930	-0.003090
-11.90	0.00	-0.002314	-0.002484	-0.002654	-0.002824	-0.002994	-0.003154
-12.25	0.00	-0.002378	-0.002548	-0.002718	-0.002888	-0.003058	-0.003218
-12.60	0.00	-0.002442	-0.002612	-0.002782	-0.002952	-0.003122	-0.003282
-12.95	0.00	-0.002506	-0.002676	-0.002846	-0.003016	-0.003186	-0.003346
-13.30	0.00	-0.002570	-0.002740	-0.002910	-0.003080	-0.003250	-0.003410
-13.65	0.00	-0.002634	-0.002804	-0.002974	-0.003144	-0.003314	-0.003474
-14.00	0.00	-0.002698	-0.002868	-0.003038	-0.003208	-0.003378	-0.003538
-14.35	0.00	-0.002762	-0.002932	-0.003102	-0.003272	-0.003442	-0.003602
-14.70	0.00	-0.002826	-0.002996	-0.003166	-0.003336	-0.003506	-0.003666
-15.05	0.00	-0.002890	-0.003060	-0.003230	-0.003400	-0.003570	-0.003730
-15.40	0.00	-0.002954	-0.003124	-0.003294	-0.003464	-0.003634	-0.003794
-15.75	0.00	-0.003018	-0.003188	-0.003358	-0.003528	-0.003698	-0.003858
-16.10	0.00	-0.003082	-0.003252	-0.003422	-0.003592	-0.003762	-0.003922
-16.45	0.00	-0.003146	-0.003316	-0.003486	-0.003656	-0.003826	-0.003986
-16.80	0.00	-0.003210	-0.003380	-0.003550	-0.003720	-0.003890	-0.004050
-17.15	0.00	-0.003274	-0.003444	-0.003614	-0.003784	-0.003954	-0.004114
-17.50	0.00	-0.003338	-0.003508	-0.003678	-0.003848	-0.004018	-0.004178
-17.85	0.00	-0.003402	-0.003572	-0.003742	-0.003912	-0.004082	-0.004242
-18.20	0.00	-0.003466	-0.003636	-0.003806	-0.003976	-0.004146	-0.004306
-18.55	0.00	-0.003530	-0.003700	-0.003870	-0.004040	-0.004210	-0.004370
-18.90	0.00	-0.003594	-0.003764	-0.003934	-0.004104	-0.004274	-0.004434
-19.25	0.00	-0.003658	-0.003828	-0.003998	-0.004168	-0.004338	-0.004498
-19.60	0.00	-0.003722	-0.003892	-0.004062	-0.004232	-0.004402	-0.004562
-19.95	0.00	-0.003786	-0.003956	-0.004126	-0.004296	-0.004466	-0.004626
-20.30	0.00	-0.003850	-0.004020	-0.004190	-0.004360	-0.004530	-0.004690
-20.65	0.00	-0.003914	-0.004084	-0.004254	-0.004424	-0.004594	-0.004754
-21.00	0.00	-0.003978	-0.004148	-0.004318	-0.004488	-0.004658	-0.004818
-21.35	0.00	-0.004042	-0.004212	-0.004382	-0.004552	-0.004722	-0.004882
-21.70	0.00	-0.004106	-0.004276	-0.004446	-0.004616	-0.004786	-0.004946
-22.05	0.00	-0.004170	-0.004340	-0.004510	-0.004680	-0.004850	-0.005010
-22.40	0.00	-0.004234	-0.004404	-0.004574	-0.004744	-0.004914	-0.005074
-22.75	0.00	-0.004298	-0.004468	-0.004638	-0.004808	-0.004978	-0.005138
-23.10	0.00	-0.004362	-0.004532	-0.004702	-0.004872	-0.005042	-0.005202
-23.45	0.00	-0.004426	-0.004596	-0.004766	-0.004936	-0.005106	-0.005266
-23.80	0.00	-0.004490	-0.004660	-0.004830	-0.005000	-0.005170	-0.005330
-24.15	0.00	-0.004554	-0.004724	-0.004894	-0.005064	-0.005234	-0.005394
-24.50	0.00	-0.004618	-0.004788	-0.004958	-0.005128	-0.005298	-0.005458
-24.85	0.00	-0.004682	-0.004852	-0.005022	-0.005192	-0.005362	-0.005522
-25.20	0.00	-0.004746	-0.004916	-0.005086	-0.005256	-0.005426	-0.005586
-25.55	0.00	-0.004810	-0.004980	-0.005150	-0.005320	-0.005490	-0.005650
-25.90	0.00	-0.004874	-0.005044	-0.005214	-0.005384	-0.005554	-0.005714
-26.25	0.00	-0.004938	-0.005108	-0.005278	-0.005448	-0.005618	-0.005778
-26.60	0.00	-0.005002	-0.005172	-0.005342	-0.005512	-0.005682	-0.005842
-26.95	0.00	-0.005066	-0.005236	-0.005406	-0.005576	-0.005746	-0.005906
-27.30	0.00	-0.005130	-0.005300	-0.005470	-0.005640	-0.005810	-0.005970
-27.65	0.00	-0.005194	-0.005364	-0.005534	-0.005704	-0.005874	-0.006034
-28.00	0.00	-0.005258	-0.005428	-0.005598	-0.005768	-0.005938	-0.006098
-28.35	0.00	-0.005322	-0.005492	-0.005662	-0.005832	-0.006002	-0.006162
-28.70	0.00	-0.005386	-0.005556	-0.005726	-0.005896	-0.006066	-0.006226
-29.05	0.00	-0.005450	-0.005620	-0.005790	-0.005960	-0.006130	-0.006290
-29.40	0.00	-0.005514	-0.005684	-0.005854	-0.006024	-0.006194	-0.006354
-29.75	0.00	-0.005578	-0.005748	-0.005918	-0.006088	-0.006258	-0.006418
-30.10	0.00	-0.005642	-0.005812	-0.005982	-0.006152	-0.006322	-0.006482
-30.45	0.00	-0.005706	-0.005876	-0.006046	-0.006216	-0.006386	-0.006546
-30.80	0.00	-0.005770	-0.005940	-0.006110	-0.006280	-0.006450	-0.006610
-31.15	0.00	-0.005834	-0.006004	-0.006174	-0.006344	-0.006514	-0.006674
-31.50	0.00	-0.005898	-0.006068	-0.006238	-0.006408	-0.006578	-0.006738
-31.85	0.00	-0.005962	-0.006132	-0.006302	-0.006472	-0.006642	-0.006802
-32.20	0.00	-0.006026	-0.006196	-0.006366	-0.006536	-0.006706	-0.006866
-32.55	0.00	-0.006090	-0.006260	-0.006430	-0.006600	-0.006770	-0.006930
-3							

Configuration: 2C-8-0-DW Jet-Induced Pressure Increments Run 186

Point	1	2	3	4	5	6	7
h/De	25.31	16.88	12.62	8.41	6.75	5.07	3.43
Total Thrust =	68.86	68.86	68.65	68.71	68.64	68.40	68.31
NPR Front =	1.00	1.00	1.00	1.00	1.00	1.00	1.00
NPR Aft =	4.00	4.00	3.99	4.00	3.99	3.98	3.98
X-loc	ACP	ACP	ACP	ACP	ACP	ACP	ACP
Y-loc	ACP	ACP	ACP	ACP	ACP	ACP	ACP
15.00	0.000097	0.000060	-0.000011	-0.000265	-0.000240	-0.000324	-0.000075
13.00	0.000043	-0.000010	-0.000109	-0.000231	-0.000327	-0.000639	-0.000854
11.00	0.000047	-0.000006	-0.000156	-0.000342	-0.000355	-0.000666	-0.001165
9.00	0.000033	-0.000075	-0.000306	-0.000400	-0.000400	-0.000713	-0.002164
7.00	0.000033	-0.000075	-0.000306	-0.000400	-0.000400	-0.000713	-0.002164
5.85	0.000079	-0.000079	-0.000130	-0.000321	-0.000450	-0.000855	-0.002357
5.50	0.000054	-0.000080	-0.000141	-0.000313	-0.000461	-0.000858	-0.002296
5.15	0.000059	-0.000066	-0.000143	-0.000314	-0.000452	-0.000858	-0.002241
4.80	0.000070	-0.000067	-0.000112	-0.000284	-0.000424	-0.000780	-0.002260
3.20	0.000059	-0.000082	-0.000133	-0.000429	-0.000596	-0.001172	-0.003095
2.85	0.000038	-0.000072	-0.000146	-0.000379	-0.000538	-0.001135	-0.003212
2.50	0.000038	-0.000072	-0.000146	-0.000379	-0.000538	-0.001135	-0.003212
2.15	0.000041	-0.000096	-0.000108	-0.000355	-0.000507	-0.001141	-0.003244
1.50	0.000042	-0.000074	-0.000119	-0.000328	-0.000486	-0.000879	-0.002824
0.00	0.000042	-0.000074	-0.000119	-0.000328	-0.000486	-0.000879	-0.002824
0.00	0.000042	-0.000074	-0.000119	-0.000328	-0.000486	-0.000879	-0.002824
-0.75	0.000042	-0.000074	-0.000119	-0.000328	-0.000486	-0.000879	-0.002824
-1.50	0.000132	-0.000136	-0.000200	-0.000370	-0.000530	-0.000774	-0.002383
-2.15	0.000166	-0.000262	-0.000301	-0.000523	-0.000764	-0.001257	-0.002246
-2.50	0.000292	-0.000345	-0.000654	-0.000998	-0.001125	-0.002264	-0.002305
-3.20	0.000466	-0.000466	-0.000884	-0.001166	-0.001448	-0.002346	-0.003685
-4.80	0.000558	-0.000667	-0.001178	-0.001429	-0.001845	-0.002454	-0.003844
-5.15	0.000558	-0.000667	-0.001178	-0.001429	-0.001845	-0.002454	-0.003844
-5.50	0.000775	-0.000172	-0.000225	-0.000359	-0.000441	-0.000873	-0.003172
-5.85	0.000775	-0.000172	-0.000225	-0.000359	-0.000441	-0.000873	-0.003172
-6.50	0.001170	-0.000109	-0.000127	-0.000370	-0.000620	-0.001169	-0.003115
-7.25	0.000042	-0.000138	-0.000159	-0.000438	-0.000738	-0.001338	-0.003377
-8.00	0.000079	-0.000107	-0.000153	-0.000408	-0.000647	-0.001327	-0.003233
-8.50	0.000047	-0.000102	-0.000180	-0.000387	-0.000700	-0.001154	-0.003147
-9.00	0.000087	-0.000109	-0.000172	-0.000472	-0.000690	-0.001883	-0.003685
-10.50	0.000087	-0.000109	-0.000172	-0.000472	-0.000690	-0.001883	-0.003685
-11.25	0.000081	-0.000128	-0.000185	-0.000438	-0.000745	-0.001431	-0.003184
-12.00	0.000072	-0.000199	-0.000182	-0.000385	-0.000662	-0.001201	-0.004082
-13.50	0.000135	-0.000199	-0.000194	-0.000416	-0.000615	-0.001135	-0.003814
4.00	0.000047	-0.000109	-0.000194	-0.000422	-0.000551	-0.001019	-0.003822
9.00	0.000047	-0.000109	-0.000194	-0.000422	-0.000551	-0.001019	-0.003822
9.00	0.000047	-0.000109	-0.000194	-0.000422	-0.000551	-0.001019	-0.003822
7.00	0.000010	-0.000257	-0.000378	-0.000544	-0.000603	-0.001096	-0.001968
7.00	0.000010	-0.000257	-0.000378	-0.000544	-0.000603	-0.001096	-0.001968
5.50	0.000059	-0.000090	-0.000244	-0.000353	-0.000594	-0.001027	-0.002128
4.00	0.000059	-0.000088	-0.000188	-0.000380	-0.000567	-0.001072	-0.002761
2.50	0.000045	-0.000085	-0.000157	-0.000395	-0.000615	-0.001021	-0.002911
1.50	0.000074	-0.000109	-0.000123	-0.000334	-0.000586	-0.000953	-0.003028
0.00	0.000074	-0.000109	-0.000123	-0.000334	-0.000586	-0.000953	-0.003028
-1.50	0.000100	-0.000211	-0.000287	-0.000506	-0.000857	-0.000687	-0.001891
-2.00	0.000100	-0.000211	-0.000287	-0.000506	-0.000857	-0.000687	-0.001891
-2.50	0.000100	-0.000211	-0.000287	-0.000506	-0.000857	-0.000687	-0.001891
-3.00	0.000075	-0.000140	-0.000193	-0.000387	-0.000547	-0.000911	-0.002887
-3.50	0.000051	-0.000104	-0.000147	-0.000351	-0.000590	-0.000923	-0.003107
-4.00	0.000051	-0.000104	-0.000147	-0.000351	-0.000590	-0.000923	-0.003107
-4.50	0.000102	-0.000109	-0.000170	-0.000429	-0.000634	-0.001150	-0.003453
-5.00	0.000081	-0.000113	-0.000168	-0.000452	-0.000734	-0.001163	-0.003675
-5.50	0.000079	-0.000107	-0.000172	-0.000408	-0.000721	-0.001266	-0.003867
-6.00	0.000041	-0.000088	-0.000278	-0.000566	-0.000841	-0.001484	-0.004264
3.00	0.000043	-0.000084	-0.000259	-0.000559	-0.000808	-0.001503	-0.004555
3.00	0.000043	-0.000084	-0.000259	-0.000559	-0.000808	-0.001503	-0.004555
3.00	0.000114	-0.000133	-0.000212	-0.000530	-0.000848	-0.001604	-0.004800
2.50	0.000078	-0.000138	-0.000198	-0.000493	-0.000712	-0.001507	-0.003366
2.50	0.000078	-0.000138	-0.000198	-0.000493	-0.000712	-0.001507	-0.003366
1.50	0.000078	-0.000138	-0.000198	-0.000493	-0.000712	-0.001507	-0.003366
0.00	0.000078	-0.000138	-0.000198	-0.000493	-0.000712	-0.001507	-0.003366
-1.50	0.000078	-0.000138	-0.000198	-0.000493	-0.000712	-0.001507	-0.003366
-2.50	0.000078	-0.000138	-0.000198	-0.000493	-0.000712	-0.001507	-0.003366
-3.00	0.000075	-0.000140	-0.000211	-0.000512	-0.000841	-0.001547	-0.003292
-3.50	0.000079	-0.000115	-0.000164	-0.000386	-0.000547	-0.000911	-0.002887
-4.00	0.000079	-0.000115	-0.000164	-0.000386	-0.000547	-0.000911	-0.002887
-4.50	0.000079	-0.000115	-0.000164	-0.000386	-0.000547	-0.000911	-0.002887
-5.00	0.000091	-0.000126	-0.000170	-0.000423	-0.000634	-0.001507	-0.003453
-6.50	0.000091	-0.000126	-0.000170	-0.000423	-0.000634	-0.001507	-0.003453

Force and Moment Summary  
 h/De = 25.31  
 Balance AL/T = -0.019  
 Pressure AH/TDe = 0.019  
 Balance AH/TDe = 0.017

Configuration: 2C-8-0-DM  
Run 187

Point	1	2	3	4	5	6	7
h/De =	17.68	11.80	8.85	5.89	4.71	3.54	2.38
Total Thrust =	51.14	52.00	51.98	52.00	52.03	52.77	52.62
NPR Front =	1.99	2.01	2.01	2.01	2.01	2.01	2.01
NPR Aft =	2.01	2.02	2.02	2.02	2.02	2.06	2.05
X-loc	ACP	ACP	ACP	ACP	ACP	ACP	ACP
Y-loc	ACP	ACP	ACP	ACP	ACP	ACP	ACP
15.00	0.000772	0.000734	-0.000422	-0.000634	-0.001532	-0.001134	-0.001236
13.00	0.000398	0.000446	-0.000278	-0.000684	-0.001304	-0.001486	-0.002020
11.00	0.000333	0.000313	-0.000189	-0.000289	-0.000532	-0.000598	-0.000750
9.00	0.000363	-0.000501	-0.000213	-0.000614	-0.001601	-0.001916	-0.003264
7.00	0.000363	-0.000501	-0.000213	-0.000614	-0.001601	-0.001916	-0.003264
5.85	0.000259	-0.000420	-0.000743	-0.000830	-0.001221	-0.001476	-0.003052
5.50	0.000362	-0.000433	-0.001060	-0.001054	-0.001683	-0.001580	-0.002574
5.15	0.000694	-0.000931	-0.000938	-0.002041	-0.001268	-0.001743	-0.002771
4.80	0.000694	-0.000931	-0.000938	-0.002041	-0.001268	-0.001743	-0.002771
3.20	0.001078	-0.001447	-0.001039	-0.001867	-0.002658	-0.002362	-0.003174
2.85	0.000664	-0.000780	-0.001460	-0.001877	-0.002942	-0.002636	-0.003174
2.50	0.000483	-0.000934	-0.000951	-0.002050	-0.003408	-0.002601	-0.003174
2.15	0.000418	-0.000934	-0.000951	-0.002050	-0.003408	-0.002601	-0.003174
1.50	0.000269	-0.000934	-0.001113	-0.001077	-0.001921	-0.001698	-0.005344
0.75	0.000203	-0.000934	-0.000854	-0.000274	0.000864	0.002460	0.009447
0.00	0.000183	-0.000429	-0.000235	0.001616	0.003962	0.005807	0.018792
-0.75	0.000041	-0.000240	-0.000185	0.001531	0.003994	0.003110	0.003537
-1.50	0.000046	-0.000160	-0.000420	0.001555	0.001662	-0.003398	-0.003772
-2.15	0.000391	-0.000409	-0.001334	-0.000324	-0.001772	-0.005697	-0.022893
-2.85	0.000345	-0.000469	-0.001658	-0.000189	-0.001143	-0.005600	-0.017718
-3.20	0.001234	-0.001293	-0.002393	-0.002763	-0.004449	-0.001063	-0.006277
-4.80	0.000710	-0.001743	-0.002153	-0.002493	-0.004342	-0.007361	-0.007440
-5.15	0.000310	-0.000644	-0.000939	-0.002122	-0.004012	-0.005073	-0.005832
-5.50	0.000234	-0.000459	-0.000949	-0.003116	-0.003783	-0.004198	-0.006144
-5.85	0.000234	-0.000459	-0.000949	-0.003116	-0.003783	-0.004198	-0.006144
-7.25	0.000203	-0.000300	-0.000884	-0.002293	-0.002131	-0.003051	-0.005931
-8.00	0.000133	-0.000355	-0.001034	-0.001905	-0.002111	-0.003287	-0.006402
-8.75	0.000133	-0.000355	-0.001034	-0.001905	-0.002111	-0.003287	-0.006402
-9.00	0.000300	-0.000454	-0.000584	-0.001441	-0.001712	-0.002544	-0.003795
-10.50	0.000259	-0.000399	-0.000754	-0.001206	-0.001577	-0.001924	-0.002309
-11.20	0.000244	-0.000380	-0.000724	-0.001192	-0.001562	-0.001912	-0.002280
-12.00	0.000244	-0.000380	-0.000724	-0.001192	-0.001562	-0.001912	-0.002280
-13.50	0.000244	-0.000380	-0.000724	-0.001192	-0.001562	-0.001912	-0.002280
-14.00	0.000244	-0.000380	-0.000724	-0.001192	-0.001562	-0.001912	-0.002280
-15.00	0.000244	-0.000380	-0.000724	-0.001192	-0.001562	-0.001912	-0.002280
-16.00	0.000244	-0.000380	-0.000724	-0.001192	-0.001562	-0.001912	-0.002280
-17.00	0.000244	-0.000380	-0.000724	-0.001192	-0.001562	-0.001912	-0.002280
-18.00	0.000244	-0.000380	-0.000724	-0.001192	-0.001562	-0.001912	-0.002280
-19.00	0.000244	-0.000380	-0.000724	-0.001192	-0.001562	-0.001912	-0.002280
-20.00	0.000244	-0.000380	-0.000724	-0.001192	-0.001562	-0.001912	-0.002280
-21.00	0.000244	-0.000380	-0.000724	-0.001192	-0.001562	-0.001912	-0.002280
-22.00	0.000244	-0.000380	-0.000724	-0.001192	-0.001562	-0.001912	-0.002280
-23.00	0.000244	-0.000380	-0.000724	-0.001192	-0.001562	-0.001912	-0.002280
-24.00	0.000244	-0.000380	-0.000724	-0.001192	-0.001562	-0.001912	-0.002280
-25.00	0.000244	-0.000380	-0.000724	-0.001192	-0.001562	-0.001912	-0.002280
-26.00	0.000244	-0.000380	-0.000724	-0.001192	-0.001562	-0.001912	-0.002280
-27.00	0.000244	-0.000380	-0.000724	-0.001192	-0.001562	-0.001912	-0.002280
-28.00	0.000244	-0.000380	-0.000724	-0.001192	-0.001562	-0.001912	-0.002280
-29.00	0.000244	-0.000380	-0.000724	-0.001192	-0.001562	-0.001912	-0.002280
-30.00	0.000244	-0.000380	-0.000724	-0.001192	-0.001562	-0.001912	-0.002280
-31.00	0.000244	-0.000380	-0.000724	-0.001192	-0.001562	-0.001912	-0.002280
-32.00	0.000244	-0.000380	-0.000724	-0.001192	-0.001562	-0.001912	-0.002280
-33.00	0.000244	-0.000380	-0.000724	-0.001192	-0.001562	-0.001912	-0.002280
-34.00	0.000244	-0.000380	-0.000724	-0.001192	-0.001562	-0.001912	-0.002280
-35.00	0.000244	-0.000380	-0.000724	-0.001192	-0.001562	-0.001912	-0.002280
-36.00	0.000244	-0.000380	-0.000724	-0.001192	-0.001562	-0.001912	-0.002280
-37.00	0.000244	-0.000380	-0.000724	-0.001192	-0.001562	-0.001912	-0.002280
-38.00	0.000244	-0.000380	-0.000724	-0.001192	-0.001562	-0.001912	-0.002280
-39.00	0.000244	-0.000380	-0.000724	-0.001192	-0.001562	-0.001912	-0.002280
-40.00	0.000244	-0.000380	-0.000724	-0.001192	-0.001562	-0.001912	-0.002280
-41.00	0.000244	-0.000380	-0.000724	-0.001192	-0.001562	-0.001912	-0.002280
-42.00	0.000244	-0.000380	-0.000724	-0.001192	-0.001562	-0.001912	-0.002280
-43.00	0.000244	-0.000380	-0.000724	-0.001192	-0.001562	-0.001912	-0.002280
-44.00	0.000244	-0.000380	-0.000724	-0.001192	-0.001562	-0.001912	-0.002280
-45.00	0.000244	-0.000380	-0.000724	-0.001192	-0.001562	-0.001912	-0.002280
-46.00	0.000244	-0.000380	-0.000724	-0.001192	-0.001562	-0.001912	-0.002280
-47.00	0.000244	-0.000380	-0.000724	-0.001192	-0.001562	-0.001912	-0.002280
-48.00	0.000244	-0.000380	-0.000724	-0.001192	-0.001562	-0.001912	-0.002280
-49.00	0.000244	-0.000380	-0.000724	-0.001192	-0.001562	-0.001912	-0.002280
-50.00	0.000244	-0.000380	-0.000724	-0.001192	-0.001562	-0.001912	-0.002280

Force and Moment Summary  
 h/De = 17.68  
 Balance AL/T = -0.021  
 Pressure AL/T = 0.009  
 Balance AM/TDe = 0.094  
 Pressure AM/TDe = 0.023

Point	1	2	3	4	5	6	7
h/De =	17.68	11.80	8.85	5.89	4.71	3.54	2.38
Total Thrust =	51.14	52.00	51.98	52.00	52.03	52.77	52.62
NPR Front =	1.99	2.01	2.01	2.01	2.01	2.01	2.01
NPR Aft =	2.01	2.02	2.02	2.02	2.02	2.06	2.05
X-loc	ACP	ACP	ACP	ACP	ACP	ACP	ACP
Y-loc	ACP	ACP	ACP	ACP	ACP	ACP	ACP
15.00	0.000772	0.000734	-0.000422	-0.000634	-0.001532	-0.001134	-0.001236
13.00	0.000398	0.000446	-0.000278	-0.000684	-0.001304	-0.001486	-0.002020
11.00	0.000333	0.000313	-0.000189	-0.000289	-0.000532	-0.000598	-0.000750
9.00	0.000363	-0.000501	-0.000213	-0.000614	-0.001601	-0.001916	-0.003264
7.00	0.000363	-0.000501	-0.000213	-0.000614	-0.001601	-0.001916	-0.003264
5.85	0.000259	-0.000420	-0.000743	-0.000830	-0.001221	-0.001476	-0.003052
5.50	0.000362	-0.000433	-0.001060	-0.001054	-0.001683	-0.001580	-0.002574
5.15	0.000694	-0.000931	-0.000938	-0.002041	-0.001268	-0.001743	-0.002771
4.80	0.000694	-0.000931	-0.000938	-0.002041	-0.001268	-0.001743	-0.002771
3.20	0.001078	-0.001447	-0.001039	-0.001867	-0.002658	-0.002362	-0.003174
2.85	0.000664	-0.000780	-0.001460	-0.001877	-0.002942	-0.002636	-0.003174
2.50	0.000483	-0.000934	-0.000951	-0.002050	-0.003408	-0.002601	-0.003174
2.15	0.000418	-0.000934	-0.000951	-0.002050	-0.003408	-0.002601	-0.003174
1.50	0.000269	-0.000934	-0.001113	-0.001077	-0.001921	-0.001698	-0.005344
0.75	0.000203	-0.000934	-0.000854	-0.000274	0.000864	0.002460	0.009447
0.00	0.000183	-0.000429	-0.000235	0.001616	0.003962	0.005807	0.018792
-0.75	0.000041	-0.000240	-0.000185	0.001531	0.003994	0.003110	0.003537
-1.50	0.000046	-0.000160	-0.000420	0.001555	0.001662	-0.003398	-0.003772
-2.15	0.000391	-0.000409	-0.001334	-0.000324	-0.001772	-0.005697	-0.022893
-2.85	0.000345	-0.000469	-0.001658	-0.000189	-0.001143	-0.005600	-0.017718
-3.20	0.001234	-0.001293	-0.002393	-0.002763	-0.004449	-0.001063	-0.006277
-4.80	0.000710	-0.001743	-0.002153	-0.002493	-0.004342	-0.007361	-0.007440
-5.15	0.000310	-0.000644	-0.000939	-0.002122	-0.004012	-0.005073	-0.005832
-5.50	0.000234	-0.000459	-0.000949	-0.003116	-0.003783	-0.004198	-0.006144
-5.85	0.000234	-0.000459	-0.000949	-0.003116	-0.003783	-0.004198	-0.006144
-7.25	0.000203	-0.000300	-0.00				



Configuration: 2C-8-0-DM Jet-Induced Pressure Increments Run 189

Point	1	2	3	4	5	6	7
h/D <sub>e</sub> =	17.67	11.79	8.84	5.89	4.69	3.51	2.33
Total Thrust =	224.78	224.51	224.50	224.51	224.49	224.50	224.44
NPR Front =	5.98	5.98	5.98	5.98	5.98	5.98	5.98
NPR Aft =	6.02	6.01	6.01	6.01	6.01	6.01	6.00
X-loc	Y-loc	ACP	ACP	ACP	ACP	ACP	ACP
15.00	0.00	-0.00099	-0.00015	-0.00199	-0.00307	-0.00470	-0.00658
13.00	0.00	-0.00011	-0.00079	-0.00044	-0.00078	-0.00126	-0.00152
11.00	0.00	-0.00041	-0.00012	-0.00042	-0.00076	-0.00127	-0.00152
9.00	0.00	-0.00180	-0.00024	-0.00047	-0.00023	-0.00103	-0.00139
7.00	0.00	-0.00180	-0.00024	-0.00047	-0.00023	-0.00103	-0.00139
5.85	0.00	-0.00215	-0.00074	-0.00076	-0.00086	-0.00108	-0.00201
5.50	0.00	-0.00315	-0.00054	-0.00079	-0.00114	-0.00151	-0.00179
5.15	0.00	-0.00650	-0.00169	-0.00086	-0.00115	-0.00141	-0.00154
4.80	0.00	-0.00856	-0.00209	-0.00082	-0.00131	-0.00166	-0.00145
3.20	0.00	-0.00657	-0.00165	-0.00124	-0.00157	-0.00204	-0.00200
2.85	0.00	-0.00418	-0.00035	-0.00070	-0.00123	-0.00208	-0.00541
2.50	0.00	-0.00324	-0.00042	-0.00070	-0.00148	-0.00416	-0.00259
2.15	0.00	-0.00259	-0.00046	-0.00052	-0.00154	-0.00419	-0.00103
1.50	0.00	-0.00181	-0.00037	-0.00017	-0.00134	-0.00392	-0.00263
0.75	0.00	-0.00191	-0.00037	-0.00017	-0.00134	-0.00392	-0.00263
0.00	0.00	-0.00058	-0.00036	-0.00017	-0.00134	-0.00392	-0.00263
-0.75	0.00	-0.00058	-0.00036	-0.00017	-0.00134	-0.00392	-0.00263
-1.50	0.00	-0.00058	-0.00036	-0.00017	-0.00134	-0.00392	-0.00263
-2.15	0.00	-0.00058	-0.00036	-0.00017	-0.00134	-0.00392	-0.00263
-2.50	0.00	-0.00107	-0.00039	-0.00051	-0.00131	-0.00327	-0.00259
-2.85	0.00	-0.00225	-0.00046	-0.00096	-0.00136	-0.00306	-0.00251
-3.20	0.00	-0.00470	-0.00072	-0.00163	-0.00206	-0.00314	-0.00269
-4.80	0.00	-0.00359	-0.00070	-0.00129	-0.00245	-0.00474	-0.00960
-5.15	0.00	-0.00219	-0.00040	-0.00082	-0.00156	-0.00261	-0.00625
-5.50	0.00	-0.00234	-0.00044	-0.00082	-0.00166	-0.00266	-0.00625
-5.85	0.00	-0.00068	-0.00023	-0.00034	-0.00156	-0.00330	-0.00625
-6.50	0.00	-0.00068	-0.00023	-0.00034	-0.00156	-0.00330	-0.00625
-7.25	0.00	-0.00019	-0.00027	-0.00018	-0.00145	-0.00270	-0.00560
-8.00	0.00	-0.00019	-0.00027	-0.00018	-0.00145	-0.00270	-0.00560
-8.75	0.00	-0.00134	-0.00034	-0.00052	-0.00168	-0.00248	-0.00515
-9.50	0.00	-0.00134	-0.00034	-0.00052	-0.00168	-0.00248	-0.00515
-10.50	0.00	-0.00192	-0.00030	-0.00050	-0.00148	-0.00237	-0.00407
-11.25	0.00	-0.00192	-0.00030	-0.00050	-0.00148	-0.00237	-0.00407
-12.00	0.00	-0.00115	-0.00020	-0.00031	-0.00119	-0.00151	-0.00159
-12.75	0.00	-0.00115	-0.00020	-0.00031	-0.00119	-0.00151	-0.00159
-13.50	0.00	-0.00134	-0.00020	-0.00031	-0.00119	-0.00151	-0.00159
-14.00	0.00	-0.00134	-0.00020	-0.00031	-0.00119	-0.00151	-0.00159
11.00	1.50	-0.00010	-0.00020	-0.00058	-0.00125	-0.00263	-0.00334
9.00	1.50	-0.00021	-0.00020	-0.00034	-0.00117	-0.00125	-0.00234
7.00	1.50	-0.00077	-0.00025	-0.00056	-0.00140	-0.00178	-0.00330
5.50	1.50	-0.00119	-0.00048	-0.00085	-0.00142	-0.00170	-0.00330
4.00	1.50	-0.00248	-0.00084	-0.00115	-0.00141	-0.00224	-0.00330
2.50	1.50	-0.00324	-0.00084	-0.00070	-0.00110	-0.00250	-0.00330
1.50	1.50	-0.00324	-0.00084	-0.00070	-0.00110	-0.00250	-0.00330
0.75	1.50	-0.00324	-0.00084	-0.00070	-0.00110	-0.00250	-0.00330
0.00	1.50	-0.00324	-0.00084	-0.00070	-0.00110	-0.00250	-0.00330
-1.50	1.50	-0.00324	-0.00084	-0.00070	-0.00110	-0.00250	-0.00330
-2.50	1.50	-0.00324	-0.00084	-0.00070	-0.00110	-0.00250	-0.00330
-3.50	1.50	-0.00324	-0.00084	-0.00070	-0.00110	-0.00250	-0.00330
-4.50	1.50	-0.00324	-0.00084	-0.00070	-0.00110	-0.00250	-0.00330
-5.50	1.50	-0.00324	-0.00084	-0.00070	-0.00110	-0.00250	-0.00330
-6.50	1.50	-0.00324	-0.00084	-0.00070	-0.00110	-0.00250	-0.00330
-7.50	1.50	-0.00324	-0.00084	-0.00070	-0.00110	-0.00250	-0.00330
-8.50	1.50	-0.00324	-0.00084	-0.00070	-0.00110	-0.00250	-0.00330
-9.50	1.50	-0.00324	-0.00084	-0.00070	-0.00110	-0.00250	-0.00330
-10.50	1.50	-0.00324	-0.00084	-0.00070	-0.00110	-0.00250	-0.00330
-11.50	1.50	-0.00324	-0.00084	-0.00070	-0.00110	-0.00250	-0.00330
-12.50	1.50	-0.00324	-0.00084	-0.00070	-0.00110	-0.00250	-0.00330
-13.50	1.50	-0.00324	-0.00084	-0.00070	-0.00110	-0.00250	-0.00330
-14.50	1.50	-0.00324	-0.00084	-0.00070	-0.00110	-0.00250	-0.00330
-15.50	1.50	-0.00324	-0.00084	-0.00070	-0.00110	-0.00250	-0.00330

Force and Moment Summary  
 h/D<sub>e</sub> = 17.67 11.79 8.84 5.89 4.69 3.51 2.33  
 Balance ΔL/T = -0.015 -0.028 -0.051 -0.114 -0.165 -0.262 -0.518  
 Pressure ΔL/T = -0.024 -0.029 -0.058 -0.107 -0.146 -0.236 -0.493  
 Balance ΔM/TDe = 0.005 0.013 0.005 0.110 0.191 0.341 0.683  
 Pressure ΔM/TDe = 0.047 0.051 0.031 0.155 0.232 0.397 0.863

Configuration: 2C-8-0-DW Jet-Induced Pressure Increments Run 190A

Point	1	2	3	4
h/De =	2.35	2.36	2.36	2.36
Total Thrust =	51.93	51.50	50.66	51.28
NPR Front =	2.01	1.95	1.88	2.11
NPR Aft =	2.02	2.06	2.09	1.89
X-loc	ACP	ACP	ACP	ACP
Y-loc	ACP	ACP	ACP	ACP
15.00	0.00	-0.001431	-0.000731	-0.000041
13.00	0.00	-0.001778	-0.001828	-0.001563
11.00	0.00	-0.002121	-0.002194	-0.002327
9.00	0.00	-0.002449	-0.002460	-0.002296
7.00	0.00	-0.002734	-0.002734	-0.002566
5.85	0.00	-0.003046	-0.003024	-0.002391
5.50	0.00	-0.003218	-0.002510	-0.003377
5.15	0.00	-0.003126	-0.003058	-0.002800
4.80	0.00	-0.003202	-0.002600	-0.003766
3.20	0.00	-0.002977	-0.001958	-0.001781
2.85	0.00	-0.002710	-0.002176	-0.001366
2.50	0.00	-0.015000	-0.014970	-0.010990
2.15	0.00	-0.014844	-0.014373	-0.011874
1.50	0.00	-0.005889	-0.003635	-0.002020
0.75	0.00	-0.009662	-0.014334	-0.016820
0.00	0.00	0.017562	0.015950	0.014909
0.00	0.00	0.004825	0.001543	0.002932
-1.50	0.00	-0.014571	-0.017371	-0.015482
-2.15	0.00	-0.023334	-0.023898	-0.025591
-2.50	0.00	-0.022402	-0.023222	-0.024769
-3.20	0.00	-0.014722	-0.017441	-0.017518
-4.80	0.00	-0.004745	-0.005723	-0.007053
-5.15	0.00	-0.006214	-0.005602	-0.006387
-5.50	0.00	-0.005070	-0.005622	-0.005259
-5.85	0.00	-0.005165	-0.005667	-0.005956
-6.50	0.00	-0.006360	-0.006081	-0.005475
-7.25	0.00	-0.006484	-0.005779	-0.004495
-8.00	0.00	-0.005155	-0.004941	-0.004059
-8.75	0.00	-0.004105	-0.003076	-0.003624
-9.50	0.00	-0.002840	-0.003096	-0.003122
-10.50	0.00	-0.001945	-0.002567	-0.002937
-11.25	0.00	-0.001945	-0.002567	-0.002091
-12.00	0.00	-0.001984	-0.002490	-0.003255
-12.75	0.00	-0.001734	-0.002597	-0.003424
-13.50	0.00	-0.001930	-0.002647	-0.003455
-14.00	0.80	-0.007436	-0.007971	-0.013964
1.00	1.50	-0.004236	-0.002750	-0.002551
1.50	1.50	-0.003686	-0.002935	-0.002959
2.00	1.50	-0.004828	-0.003537	-0.003112
2.50	1.50	-0.003602	-0.003054	-0.002556
3.00	1.50	-0.003873	-0.007710	-0.008409
3.50	1.50	-0.016054	-0.015831	-0.017465
4.00	1.50	-0.009702	-0.006081	-0.001610
4.50	1.50	-0.014740	-0.012137	-0.009819
5.00	1.50	-0.024145	-0.018329	-0.018500
5.50	1.50	-0.021145	-0.025506	-0.025127
6.00	1.50	-0.007855	-0.007861	-0.008141
6.50	1.50	-0.010782	-0.010378	-0.008400
7.00	1.50	-0.003215	-0.002919	-0.003752
7.50	1.50	-0.002668	-0.002965	-0.003132
8.00	1.50	-0.001685	-0.002703	-0.003204
8.50	1.50	-0.002065	-0.003173	-0.003208
9.00	3.00	-0.008763	-0.005272	-0.004223
9.50	3.00	-0.006305	-0.005606	-0.004712
10.00	3.00	-0.007160	-0.004849	-0.004781
10.50	3.00	-0.013984	-0.015093	-0.014250
11.00	3.00	-0.004190	-0.008405	-0.006228
11.50	3.00	-0.011932	-0.014665	-0.013251
12.00	3.00	-0.007955	-0.007861	-0.009141
12.50	3.00	-0.016392	-0.015280	-0.012606
13.00	3.00	-0.016392	-0.015280	-0.012606
13.50	3.00	-0.003515	-0.002919	-0.003752

Force and Moment Summary

h/De =	2.35	2.36	2.36	2.36
Balance AL/T =	-0.536	-0.539	-0.551	-0.550
Pressure AL/T =	-0.531	-0.522	-0.525	-0.554
Balance ΔM/TDe =	0.313	0.386	0.485	0.204
Pressure ΔM/TDe =	0.639	0.752	0.822	0.497

Configuration: 2C-8-0-DW Jet-Induced Pressure Increments Run 190B

Point	4	5	6
Total Thrust =	51.28	51.37	51.33
NPR Front =	2.11	2.11	2.11
NPR Aft =	1.89	1.90	1.89
X-loc	ACP	ACP	ACP
h/be =	3.54	3.54	3.54
Y-loc	ACP	ACP	ACP
15.00	0.00	-0.000452	-0.000085
13.00	0.00	-0.002550	-0.000939
11.00	0.00	-0.003340	-0.002079
9.00	0.00	-0.003565	-0.001974
7.00	0.00	-0.003566	-0.001974
5.85	0.00	-0.005041	-0.001641
5.50	0.00	-0.004060	-0.003268
5.15	0.00	-0.003806	-0.001800
4.80	0.00	-0.003019	-0.003203
4.20	0.00	-0.005032	-0.003315
2.85	0.00	-0.013266	-0.003174
2.50	0.00	-0.014599	-0.003172
2.15	0.00	-0.012123	-0.003572
1.50	0.00	-0.002309	-0.004155
0.75	0.00	0.015947	-0.001888
0.00	0.00	0.011157	-0.001162
-1.50	0.00	-0.007964	-0.003270
-2.15	0.00	-0.020493	-0.003289
-2.50	0.00	-0.021199	-0.005446
-3.20	0.00	-0.003747	-0.002825
-4.80	0.00	-0.007797	-0.006738
-5.15	0.00	-0.006896	-0.006535
-5.85	0.00	-0.005756	-0.006728
-6.50	0.00	-0.005443	-0.005398
-7.25	0.00	-0.006830	-0.003953
-8.00	0.00	-0.005691	-0.003079
-8.75	0.00	-0.004765	-0.002649
-9.50	0.00	-0.003403	-0.002472
-10.50	0.00	-0.002091	-0.002113
-11.25	0.00	-0.002091	-0.002113
-12.00	0.00	-0.001119	-0.001234
-12.75	0.00	-0.000947	-0.001001
-13.50	0.00	-0.001331	-0.000935
-4.00	0.80	-0.005518	-0.009926
11.00	1.50	-0.003883	-0.002079
9.00	1.50	-0.004627	-0.002586
7.00	1.50	-0.005699	-0.003530
5.50	1.50	-0.005733	-0.003912
4.00	1.50	-0.004249	-0.004994
2.50	1.50	-0.012768	-0.002778
0.00	1.50	-0.014071	-0.004696
-1.50	1.50	-0.006430	-0.001941
-2.50	1.50	-0.024127	-0.002926
-4.00	1.50	-0.024127	-0.002926
-5.50	1.50	-0.008167	-0.007618
-6.50	1.50	-0.008319	-0.006116
-8.00	1.50	-0.008319	-0.006116
-9.50	1.50	-0.003660	-0.001946
-10.50	1.50	-0.002764	-0.002027
-12.00	1.50	-0.001265	-0.001441
-13.50	1.50	-0.001418	-0.001142
9.00	3.00	-0.011098	-0.008135
7.00	3.00	-0.009572	-0.006754
5.50	3.00	-0.007978	-0.005573
4.00	3.00	-0.005819	-0.004594
2.50	3.00	-0.013342	-0.003414
1.50	3.00	-0.013251	-0.005029
0.00	3.00	-0.001651	-0.001946
-1.50	3.00	-0.005327	-0.000051
-2.50	3.00	-0.008167	-0.007618
-4.00	3.00	-0.018385	-0.007037
-5.50	3.00	-0.018385	-0.007037
-6.50	3.00	-0.003660	-0.001946

Force and Moment Summary  
 Balance AI/Dm = 2.36 3.54 5.89  
 Pressure AI/IT = -0.550 -0.308 -0.138  
 Balance AM/IT = -0.354 -0.285 -0.130  
 Pressure AM/TDe = 0.497 0.170 0.091



Configuration: 2C-8-0-DW Jet-Induced Pressure Increments Run 190C

	Point h/De =	5.88	3.52	2.33	9
Total Thrust =	50.58	50.61	50.62	50.62	2.33
NFR Front =	1.88	1.88	1.88	1.88	50.62
NFR Aft =	2.09	2.09	2.09	2.09	1.88
X-loc	Y-loc	ΔCP	ΔCP	ΔCP	ΔCP
15.00	0.00	0.00342	-0.00071	-0.00122	0.00071
13.00	0.00	-0.00490	-0.00178	-0.00177	0.00177
11.00	0.00	-0.00847	-0.00129	-0.00260	0.00260
9.00	0.00	-0.01423	-0.00170	-0.00324	0.00324
7.00	0.00	-0.01423	-0.00170	-0.00324	0.00324
5.85	0.00	-0.002373	-0.001735	-0.002928	0.002928
5.50	0.00	-0.001627	-0.002367	-0.002479	0.002479
5.15	0.00	-0.001426	-0.003447	-0.002535	0.002535
4.80	0.00	-0.001875	-0.004114	-0.004182	0.004182
3.20	0.00	0.001121	-0.001177	-0.001578	0.001578
2.85	0.00	0.001675	-0.002458	-0.011685	0.011685
2.50	0.00	0.001470	-0.002458	-0.015287	0.015287
2.15	0.00	0.001762	-0.000876	-0.013222	0.013222
1.50	0.00	0.002536	0.001945	-0.006667	0.006667
0.75	0.00	0.003334	0.009446	0.018782	0.018782
0.00	0.00	-0.001325	0.007511	0.016860	0.016860
-0.75	0.00	-0.002217	0.001668	-0.002508	0.002508
-1.50	0.00	-0.003111	-0.009093	-0.020127	0.020127
-2.15	0.00	-0.003881	-0.009299	-0.025837	0.025837
-2.50	0.00	-0.003876	-0.008281	-0.018125	0.018125
-3.20	0.00	-0.004046	-0.004028	-0.007560	0.007560
-4.80	0.00	-0.002618	-0.005223	-0.006109	0.006109
-5.15	0.00	-0.002243	-0.004217	-0.005412	0.005412
-5.85	0.00	-0.002285	-0.003417	-0.005791	0.005791
-6.50	0.00	-0.001818	-0.003489	-0.004349	0.004349
-7.25	0.00	-0.001597	-0.002730	-0.003883	0.003883
-8.00	0.00	-0.001479	-0.002632	-0.003657	0.003657
-8.75	0.00	-0.001453	-0.001986	-0.003385	0.003385
-10.50	0.00	-0.001370	-0.001734	-0.003087	0.003087
-11.25	0.00	-0.001196	-0.001734	-0.003087	0.003087
-12.00	0.00	-0.001145	-0.001498	-0.003411	0.003411
-12.75	0.00	-0.001093	-0.001149	-0.003360	0.003360
-13.50	0.80	-0.005561	-0.016551	-0.014000	0.014000
11.00	1.50	-0.001688	-0.001412	-0.002996	0.002996
9.00	1.50	-0.001306	-0.001585	-0.003435	0.003435
7.00	1.50	-0.001739	-0.001498	-0.003521	0.003521
5.50	1.50	-0.002150	-0.004149	-0.002631	0.002631
4.00	1.50	-0.001492	-0.007003	-0.010122	0.010122
2.50	1.50	-0.000048	-0.004096	-0.016752	0.016752
1.50	1.50	0.001212	0.001647	-0.003959	0.003959
0.00	1.50	-0.001556	0.005890	0.012312	0.012312
-1.50	1.50	-0.003317	-0.007348	-0.021441	0.021441
-2.50	1.50	-0.003497	-0.010774	-0.026311	0.026311
-4.00	1.50	-0.002464	-0.004787	-0.008412	0.008412
-5.50	1.50	-0.002177	-0.004155	-0.008586	0.008586
-6.50	1.50	-0.002177	-0.004155	-0.008586	0.008586
-8.00	1.50	-0.001566	-0.002468	-0.003673	0.003673
-9.50	1.50	-0.001505	-0.002191	-0.003354	0.003354
-12.00	1.50	-0.001355	-0.001857	-0.003272	0.003272
-13.50	1.50	-0.001053	-0.001426	-0.004062	0.004062
9.00	3.00	-0.001408	-0.001759	-0.003929	0.003929
7.00	3.00	-0.001622	-0.001855	-0.005207	0.005207
5.50	3.00	-0.001836	-0.004511	-0.009013	0.009013
4.00	3.00	-0.001016	-0.006036	-0.014670	0.014670
2.50	3.00	-0.000196	-0.003600	-0.007278	0.007278
1.50	3.00	-0.000098	0.002242	-0.002728	0.002728
0.00	3.00	-0.001248	0.002791	0.004852	0.004852
-1.50	3.00	-0.002624	-0.008327	-0.018063	0.018063
-2.50	3.00	-0.002464	-0.004787	-0.008412	0.008412
-4.00	3.00	-0.002777	-0.008312	-0.014193	0.014193
-5.50	3.00	-0.002777	-0.008312	-0.014193	0.014193
-6.50	3.00	-0.001566	-0.002468	-0.003673	0.003673

Force and Moment Summary

	5.88	3.52	2.33
Balance	h/De =	5.88	3.52
Pressure	AL/T =	-0.159	-0.306
Balance	AL/T =	-0.162	-0.291
Pressure	ΔH/TDe =	0.209	0.306
Pressure	ΔH/TDe =	0.355	0.579
			0.856

Configuration: 2C-8-0-DW Jet-Induced Pressure Increments Run 1900

Point	10	11	12	Point	10	11	12		
h/De =	2.34	3.54	5.89	Total Thrust =	2.34	3.54	5.89		
NPR Front =	51.35	51.36	51.35	NPR Front =	51.35	51.36	51.35		
NPR Aft =	1.95	1.95	1.95	NPR Aft =	1.95	1.95	1.95		
X-loc	Y-loc	ΔCP	ΔCP	X-loc	Y-loc	ΔCP	ΔCP		
13.00	0.00	-0.00201	-0.000156	0.000116	-8.00	3.00	-0.005795	-0.005662	-0.001603
15.00	0.00	-0.001819	-0.001235	-0.000487	-9.50	3.00	-0.005795	-0.005662	-0.001603
17.00	0.00	-0.002432	-0.001567	-0.000829	-10.50	3.00	-0.002548	-0.002674	-0.001542
19.00	0.00	-0.003311	-0.001893	-0.000683	-12.00	3.00	-0.002918	-0.001866	-0.001315
7.00	0.00	-0.003311	-0.001893	-0.000683	-13.50	3.00	-0.003085	-0.001335	-0.001385
5.85	0.00	-0.002977	-0.001520	-0.001478	6.00	5.00	-0.004728	-0.003179	-0.001759
5.15	0.00	-0.002659	-0.001735	-0.002216	4.00	5.00	-0.006782	-0.005163	-0.001839
4.80	0.00	-0.002694	-0.002606	-0.001941	2.00	5.00	-0.009721	-0.004144	-0.000166
3.20	0.00	-0.002062	-0.003474	0.002749	0.00	5.00	-0.001568	0.000166	0.001125
2.85	0.00	-0.013392	-0.004673	0.001439	-2.00	5.00	-0.013130	-0.005293	-0.001558
2.15	0.00	-0.014557	-0.005149	0.003256	-4.00	5.00	-0.012011	-0.006885	-0.003954
0.75	0.00	-0.005042	-0.001047	0.000501	-6.00	5.00	-0.007259	-0.006674	-0.002085
0.00	0.00	0.012374	0.004914	0.001826	-10.00	5.00	-0.003211	-0.003877	-0.001733
-0.75	0.00	-0.002063	-0.002227	-0.001077	-12.00	5.00	-0.002529	-0.002064	-0.001160
-2.15	0.00	-0.023537	-0.008114	-0.003231	-3.50	6.00	-0.005587	-0.002440	-0.001502
-2.85	0.00	-0.018507	-0.006488	-0.002422	-4.00	7.00	-0.007852	-0.005153	-0.002703
-3.20	0.00	-0.006007	-0.001845	-0.001881	-8.00	7.00	-0.002879	-0.001427	-0.000219
-4.80	0.00	-0.007348	-0.006743	-0.003879	-11.60	7.00	-0.002110	-0.001953	-0.001523
-5.15	0.00	-0.005593	-0.004615	-0.003044	0.00	8.50	-0.006618	-0.001055	-0.000296
-5.85	0.00	-0.006314	-0.004615	-0.002513	-4.00	9.00	-0.004526	-0.003119	-0.001723
-7.85	0.00	-0.004231	-0.003326	-0.002220	-11.20	9.00	-0.001828	-0.001627	-0.000864
-9.20	0.00	-0.004823	-0.003943	-0.002407	-4.00	10.00	-0.002954	-0.002511	-0.001492
-9.25	0.00	-0.004823	-0.003943	-0.002407	-4.00	11.00	-0.002196	-0.001657	-0.001718
-8.70	0.00	-0.004562	-0.003443	-0.001957	-8.00	11.00	-0.001427	-0.000748	-0.000954
-9.50	0.00	-0.004562	-0.003443	-0.001957	-8.00	12.00	-0.001040	-0.000799	-0.001196
-9.50	0.00	-0.004562	-0.003443	-0.001957	-10.60	12.00	-0.000678	-0.000613	-0.000809
-9.50	0.00	-0.004562	-0.003443	-0.001957	-8.00	13.00	-0.000945	-0.001125	-0.001171
-10.50	0.00	-0.002766	-0.001845	-0.001356	Force and Moment Summary				
-11.25	0.00	-0.002766	-0.001845	-0.001356	Balance	h/De =	2.34	3.54	5.89
-12.00	0.00	-0.002521	-0.000829	-0.001184	Balance	AL/T =	-0.548	-0.302	-0.146
-12.75	0.00	-0.004935	-0.000829	-0.001184	Balance	AM/T =	-0.527	-0.280	-0.119
-13.50	0.00	-0.004222	-0.000829	-0.001097	Balance	AN/TDe =	0.402	0.254	0.166
4.00	0.00	-0.004921	-0.000796	-0.000719	Pressure	ΔM/TDe =	0.713	0.542	0.331
11.00	1.50	-0.00250	-0.001431	-0.000628					
9.00	1.50	-0.003109	-0.001693	-0.000643					
7.00	1.50	-0.004477	-0.001532	-0.000874					
5.50	1.50	-0.003849	-0.001293	-0.000816					
4.00	1.50	-0.004125	-0.003690	-0.002621					
2.50	1.50	-0.017678	-0.006797	-0.000051					
1.50	1.50	-0.006089	-0.000854	0.002670					
0.00	1.50	0.010092	0.006416	0.000025					
-1.50	1.50	-0.017447	-0.005621	-0.001932					
-2.50	1.50	-0.025872	-0.009851	-0.001525					
-4.00	1.50	-0.025872	-0.009851	-0.001525					
-5.50	1.50	-0.009309	-0.004772	-0.003206					
-6.50	1.50	-0.009767	-0.002286	-0.002200					
-8.00	1.50	-0.009767	-0.002286	-0.002200					
-9.50	1.50	-0.003120	-0.003958	-0.001315					
-10.50	1.50	-0.002807	-0.002259	-0.001497					
-12.00	1.50	-0.002781	-0.001602	-0.000951					
-13.50	1.50	-0.002246	-0.001633	-0.001223					
9.00	3.00	-0.006893	-0.002174	-0.000789					
7.00	3.00	-0.007998	-0.002295	-0.000900					
5.50	3.00	-0.005069	-0.002598	-0.003072					
4.00	3.00	-0.006598	-0.005948	-0.003290					
2.50	3.00	-0.013714	-0.005234	-0.001563					
1.50	3.00	-0.012357	-0.003610	0.000076					
0.00	3.00	0.004450	0.003509	0.001031					
-1.50	3.00	-0.014278	-0.004449	-0.001330					
-2.50	3.00	-0.009309	-0.004772	-0.003206					
-4.00	3.00	-0.014577	-0.008685	-0.002903					
-5.50	3.00	-0.014577	-0.008685	-0.002903					
-6.50	3.00	-0.003120	-0.003958	-0.001315					

Point	1	2	3	4	5	6	7	8	9	10	11	12
h/D <sub>e</sub>	5.87	3.51	2.33	2.33	3.51	5.86	5.87	3.51	2.32	2.32	3.51	5.88
Total Thrust =	136.65	136.77	136.74	136.86	136.89	136.83	136.96	136.94	136.88	135.91	135.88	135.86
NPR Front =	3.98	3.98	3.98	3.89	3.89	3.88	4.08	4.08	4.08	3.75	3.75	3.75
NPR Aft =	4.02	4.02	4.12	4.12	4.12	3.92	3.92	3.92	3.92	4.21	4.21	4.21
X-loc	ACP	ACP	ACP	ACP	ACP	ACP	ACP	ACP	ACP	ACP	ACP	ACP
Y-loc	ACP	ACP	ACP	ACP	ACP	ACP	ACP	ACP	ACP	ACP	ACP	ACP
15.00	0.00	-0.00553	-0.001049	-0.000983	-0.000867	-0.000588	-0.000456	-0.000448	-0.001101	-0.001151	-0.000776	-0.000387
13.00	0.00	-0.000883	-0.001645	-0.002088	-0.001979	-0.001244	-0.000764	-0.000913	-0.002050	-0.001875	-0.000513	-0.000659
11.00	0.00	-0.000908	-0.001646	-0.002449	-0.002343	-0.001298	-0.000809	-0.000994	-0.002478	-0.002283	-0.001281	-0.000716
9.00	0.00	-0.000933	-0.001807	-0.002751	-0.002744	-0.001651	-0.000841	-0.001028	-0.002776	-0.002752	-0.001446	-0.001162
7.00	0.00	-0.000933	-0.001807	-0.002751	-0.002744	-0.001651	-0.000841	-0.001028	-0.002776	-0.002752	-0.001446	-0.001162
5.85	0.00	-0.001248	-0.001887	-0.002552	-0.002552	-0.001249	-0.000919	-0.001399	-0.002306	-0.002439	-0.001054	-0.002003
5.50	0.00	-0.001378	-0.001717	-0.002260	-0.002260	-0.001378	-0.001004	-0.001390	-0.002412	-0.002412	-0.001378	-0.001774
5.15	0.00	-0.001425	-0.001671	-0.002078	-0.002078	-0.001425	-0.001004	-0.001390	-0.002412	-0.002412	-0.001378	-0.001774
4.80	0.00	-0.001554	-0.001613	-0.002018	-0.002018	-0.001554	-0.001004	-0.001390	-0.002412	-0.002412	-0.001378	-0.001774
3.20	0.00	-0.000962	-0.002855	-0.002855	-0.001929	-0.001872	-0.001997	-0.001887	-0.002309	-0.002309	-0.002592	-0.002033
2.85	0.00	-0.001248	-0.003420	-0.003420	-0.001457	-0.001457	-0.000861	-0.002226	-0.002226	-0.002226	-0.001896	-0.002317
2.50	0.00	-0.001763	-0.004658	-0.004658	-0.001241	-0.001241	-0.000855	-0.002184	-0.002184	-0.002184	-0.001896	-0.002317
2.15	0.00	-0.001569	-0.005479	-0.005479	-0.001141	-0.001141	-0.000855	-0.002184	-0.002184	-0.002184	-0.001896	-0.002317
1.50	0.00	-0.001488	-0.004519	-0.004519	-0.001041	-0.001041	-0.000855	-0.002184	-0.002184	-0.002184	-0.001896	-0.002317
0.75	0.00	-0.001579	-0.004885	-0.004885	-0.000941	-0.000941	-0.000855	-0.002184	-0.002184	-0.002184	-0.001896	-0.002317
0.00	0.00	-0.000936	-0.003489	-0.003489	-0.000736	-0.000736	-0.000400	-0.001731	-0.003846	-0.003812	-0.005260	-0.001447
0.00	0.00	-0.000936	-0.003489	-0.003489	-0.000736	-0.000736	-0.000400	-0.001731	-0.003846	-0.003812	-0.005260	-0.001447
-0.75	0.00	-0.000952	-0.003549	-0.003549	-0.000736	-0.000736	-0.000400	-0.001731	-0.003846	-0.003812	-0.005260	-0.001447
-1.50	0.00	-0.000611	-0.000687	-0.000687	-0.000611	-0.000611	-0.000611	-0.000611	-0.000611	-0.000611	-0.000611	-0.000611
-2.15	0.00	-0.000611	-0.000687	-0.000687	-0.000611	-0.000611	-0.000611	-0.000611	-0.000611	-0.000611	-0.000611	-0.000611
-2.85	0.00	-0.000611	-0.000687	-0.000687	-0.000611	-0.000611	-0.000611	-0.000611	-0.000611	-0.000611	-0.000611	-0.000611
-3.20	0.00	-0.000611	-0.000687	-0.000687	-0.000611	-0.000611	-0.000611	-0.000611	-0.000611	-0.000611	-0.000611	-0.000611
-4.80	0.00	-0.002755	-0.003816	-0.003816	-0.003420	-0.003420	-0.003420	-0.003420	-0.003420	-0.003420	-0.003420	-0.003420
-5.15	0.00	-0.001919	-0.005051	-0.005051	-0.003317	-0.003317	-0.003317	-0.003317	-0.003317	-0.003317	-0.003317	-0.003317
-5.50	0.00	-0.002037	-0.004889	-0.004889	-0.005786	-0.005786	-0.005786	-0.005786	-0.005786	-0.005786	-0.005786	-0.005786
-6.50	0.00	-0.001834	-0.004747	-0.004747	-0.005253	-0.005253	-0.005253	-0.005253	-0.005253	-0.005253	-0.005253	-0.005253
-7.25	0.00	-0.002277	-0.003414	-0.003414	-0.006061	-0.006061	-0.006061	-0.006061	-0.006061	-0.006061	-0.006061	-0.006061
-8.00	0.00	-0.001701	-0.002780	-0.002780	-0.005586	-0.005586	-0.005586	-0.005586	-0.005586	-0.005586	-0.005586	-0.005586
-8.75	0.00	-0.001330	-0.002933	-0.002933	-0.004445	-0.004445	-0.004445	-0.004445	-0.004445	-0.004445	-0.004445	-0.004445
-9.50	0.00	-0.001381	-0.002740	-0.002740	-0.004363	-0.004363	-0.004363	-0.004363	-0.004363	-0.004363	-0.004363	-0.004363
-10.50	0.00	-0.001294	-0.001956	-0.001956	-0.002432	-0.002432	-0.002432	-0.002432	-0.002432	-0.002432	-0.002432	-0.002432
-11.25	0.00	-0.001194	-0.001956	-0.001956	-0.002432	-0.002432	-0.002432	-0.002432	-0.002432	-0.002432	-0.002432	-0.002432
-12.00	0.00	-0.001194	-0.001956	-0.001956	-0.002432	-0.002432	-0.002432	-0.002432	-0.002432	-0.002432	-0.002432	-0.002432
-12.75	0.00	-0.000992	-0.001378	-0.001378	-0.001285	-0.001285	-0.001285	-0.001285	-0.001285	-0.001285	-0.001285	-0.001285
-13.50	0.00	-0.000874	-0.001574	-0.001574	-0.004693	-0.004693	-0.004693	-0.004693	-0.004693	-0.004693	-0.004693	-0.004693
4.00	0.80	-0.002402	-0.003920	-0.003920	-0.002712	-0.002712	-0.002712	-0.002712	-0.002712	-0.002712	-0.002712	-0.002712
8.00	1.50	-0.001205	-0.002795	-0.002795	-0.003096	-0.003096	-0.003096	-0.003096	-0.003096	-0.003096	-0.003096	-0.003096
12.00	1.50	-0.001157	-0.002340	-0.002340	-0.003376	-0.003376	-0.003376	-0.003376	-0.003376	-0.003376	-0.003376	-0.003376
16.00	1.50	-0.001600	-0.003155	-0.003155	-0.004276	-0.004276	-0.004276	-0.004276	-0.004276	-0.004276	-0.004276	-0.004276
20.00	1.50	-0.001956	-0.004816	-0.004816	-0.003591	-0.003591	-0.003591	-0.003591	-0.003591	-0.003591	-0.003591	-0.003591
24.00	1.50	-0.000532	-0.003540	-0.003540	-0.009888	-0.009888	-0.009888	-0.009888	-0.009888	-0.009888	-0.009888	-0.009888
28.00	1.50	-0.000010	-0.000957	-0.000957	-0.006600	-0.006600	-0.006600	-0.006600	-0.006600	-0.006600	-0.006600	-0.006600
32.00	1.50	-0.000270	-0.004737	-0.004737	-0.023145	-0.023145	-0.023145	-0.023145	-0.023145	-0.023145	-0.023145	-0.023145
36.00	1.50	-0.002128	-0.005925	-0.005925	-0.007546	-0.007546	-0.007546	-0.007546	-0.007546	-0.007546	-0.007546	-0.007546
40.00	1.50	-0.002303	-0.003606	-0.003606	-0.008390	-0.008390	-0.008390	-0.008390	-0.008390	-0.008390	-0.008390	-0.008390
44.00	1.50	-0.001344	-0.004168	-0.004168	-0.004615	-0.004615	-0.004615	-0.004615	-0.004615	-0.004615	-0.004615	-0.004615
48.00	1.50	-0.001227	-0.002683	-0.002683	-0.002693	-0.002693	-0.002693	-0.002693	-0.002693	-0.002693	-0.002693	-0.002693
52.00	1.50	-0.000819	-0.001872	-0.001872	-0.001542	-0.001542	-0.001542	-0.001542	-0.001542	-0.001542	-0.001542	-0.001542
56.00	1.50	-0.002809	-0.005278	-0.005278	-0.008753	-0.008753	-0.008753	-0.008753	-0.008753	-0.008753	-0.008753	-0.008753
60.00	1.50	-0.002677	-0.005678	-0.005678	-0.007476	-0.007476	-0.007476	-0.007476	-0.007476	-0.007476	-0.007476	-0.007476
64.00	1.50	-0.001969	-0.004317	-0.004317	-0.005322	-0.005322	-0.005322	-0.005322	-0.005322	-0.005322	-0.005322	-0.005322
68.00	1.50	-0.001494	-0.004482	-0.004482	-0.003881	-0.003881	-0.003881	-0.003881	-0.003881	-0.003881	-0.003881	-0.003881
72.00	1.50	-0.001254	-0.003859	-0.003859	-0.001765	-0.001765	-0.001765	-0.001765	-0.001765	-0.001765	-0.001765	-0.001765
76.00	1.50	-0.001254	-0.003859	-0.003859	-0.001765	-0.001765	-0.001765	-0.001765	-0.001765	-0.001765	-0.001765	-0.001765
80.00	1.50	-0.000889	-0.003596	-0.003596	-0.004637	-0.004637	-0.004637	-0.004637	-0.004637	-0.004637	-0.004637	-0.004637
84.00	1.50	-0.000889	-0.003596	-0.003596	-0.004637	-0.004637	-0.004637	-0.004637	-0.004637	-0.004637	-0.004637	-0.004637
88.00	1.50	-0.002128	-0.005925	-0.005925	-0.007546	-0.007546	-0.007546	-0.007546	-0.007546	-0.007546	-0.007546	-0.007546
92.00	1.50	-0.001803	-0.007122	-0.007122	-0.012634	-0.012634	-0.012634	-0.012634	-0.012634	-0.012634	-0.012634	-0.012634
96.00	1.50	-0.001803	-0.007122	-0.007122	-0.012634	-0.012634	-0.012634	-0.012634	-0.012634	-0.012634	-0.012634	-0.012634
100.00	1.50	-0.001344	-0.004168	-0.004168	-0.006415	-0.006415	-0.006415	-0.006415	-0.006415	-0.006415	-0.006415	-0.006415

Jet-Induced Pressure Increments  
Run 191

Page 2/2

Configuration: 2C-8-0-DW

Point	1	2	3	4	5	6	7	8	9	10	11	12
h/Dc =	5.87	3.51	2.33	2.33	3.51	5.86	5.87	3.51	2.32	2.32	3.51	5.88
Total Thrust =	136.65	136.77	136.74	136.86	136.89	136.83	136.96	136.94	136.88	135.91	135.88	135.86
NPR Front =	3.98	3.98	3.98	3.89	3.89	3.88	4.08	4.08	4.08	3.75	3.75	3.75
NPR Aft =	4.02	4.02	4.12	4.12	4.12	4.12	3.92	3.92	3.92	4.21	4.21	4.21
X-loc	ACP	ACP	ACP	ACP	ACP	ACP	ACP	ACP	ACP	ACP	ACP	ACP
Y-loc	ACP	ACP	ACP	ACP	ACP	ACP	ACP	ACP	ACP	ACP	ACP	ACP
-8.00	3.00	-0.001965	-0.003725	-0.008472	-0.008489	-0.003893	-0.001453	-0.003529	-0.009800	-0.008287	-0.004132	-0.001621
-9.50	3.00	-0.001965	-0.003725	-0.008472	-0.008489	-0.003893	-0.001453	-0.003529	-0.009800	-0.008287	-0.004132	-0.001621
-10.50	3.00	-0.001554	-0.003695	-0.003202	-0.002768	-0.003005	-0.001583	-0.002862	-0.003156	-0.002698	-0.001462	-0.001462
-12.00	3.00	-0.001140	-0.002140	-0.001941	-0.001643	-0.001270	-0.000711	-0.001822	-0.001415	-0.002195	-0.001531	-0.001435
-13.50	3.00	-0.000726	-0.001215	-0.001538	-0.001538	-0.001258	-0.001258	-0.000976	-0.001079	-0.002938	-0.001905	-0.001399
0.00	3.00	-0.002637	-0.003278	-0.004693	-0.002802	-0.001538	-0.001503	-0.003236	-0.004471	-0.004815	-0.002523	-0.001648
4.00	3.00	-0.002150	-0.003912	-0.005613	-0.004267	-0.001714	-0.001684	-0.003289	-0.006163	-0.006353	-0.004330	-0.001661
2.00	3.00	-0.001567	-0.003938	-0.010142	-0.009315	-0.003504	-0.000909	-0.004291	-0.009399	-0.009618	-0.003013	-0.000142
0.00	3.00	-0.000597	-0.000990	-0.01854	-0.01008	-0.003185	-0.002334	-0.001635	-0.002610	-0.002323	-0.000074	-0.000767
-2.00	3.00	-0.000110	-0.003345	-0.010986	-0.010878	-0.003692	-0.001433	-0.001772	-0.002198	-0.003340	-0.004793	-0.002624
-4.00	3.00	-0.001525	-0.006095	-0.014701	-0.013076	-0.006068	-0.002189	-0.005391	-0.014670	-0.013926	-0.005731	-0.002649
-6.00	3.00	-0.001525	-0.006095	-0.014701	-0.013076	-0.006068	-0.002189	-0.005391	-0.014670	-0.013926	-0.005731	-0.002649
-8.00	3.00	-0.001525	-0.006095	-0.014701	-0.013076	-0.006068	-0.002189	-0.005391	-0.014670	-0.013926	-0.005731	-0.002649
-10.00	3.00	-0.001163	-0.003127	-0.002845	-0.002714	-0.002913	-0.002057	-0.001878	-0.002114	-0.002224	-0.004400	-0.002238
-12.00	3.00	-0.000876	-0.001798	-0.001558	-0.002041	-0.001477	-0.001386	-0.000586	-0.001347	-0.001159	-0.002639	-0.001599
3.50	3.00	-0.003874	-0.003276	-0.004389	-0.004627	-0.002823	-0.001007	-0.001533	-0.003018	-0.004484	-0.004512	-0.003661
0.00	3.00	-0.003874	-0.003276	-0.004389	-0.004627	-0.002823	-0.001007	-0.001533	-0.003018	-0.004484	-0.004512	-0.003661
4.00	3.00	-0.004403	-0.003492	-0.004594	-0.004184	-0.001889	-0.001889	-0.001038	-0.001895	-0.003506	-0.004782	-0.000499
8.00	3.00	-0.004403	-0.003492	-0.004594	-0.004184	-0.001889	-0.001889	-0.001038	-0.001895	-0.003506	-0.004782	-0.000499
-11.60	3.00	-0.008531	-0.001725	-0.001987	-0.001845	-0.001124	-0.001124	-0.000378	-0.002059	-0.003603	-0.004120	-0.002326
0.00	3.00	-0.008531	-0.001725	-0.001987	-0.001845	-0.001124	-0.001124	-0.000378	-0.002059	-0.003603	-0.004120	-0.002326
8.50	3.00	-0.009312	-0.002382	-0.002237	-0.004237	-0.001397	-0.001397	-0.000948	-0.001030	-0.001030	-0.001775	-0.001492
8.00	3.00	-0.009312	-0.002382	-0.002237	-0.004237	-0.001397	-0.001397	-0.000948	-0.001030	-0.001030	-0.001775	-0.001492
-4.00	3.00	-0.000863	-0.000974	-0.001179	-0.001344	-0.001624	-0.001624	-0.001637	-0.001637	-0.001637	-0.001637	-0.001637
-11.20	3.00	-0.000863	-0.000974	-0.001179	-0.001344	-0.001624	-0.001624	-0.001637	-0.001637	-0.001637	-0.001637	-0.001637
-4.00	3.00	-0.000857	-0.001775	-0.002568	-0.003505	-0.002105	-0.001329	-0.000546	-0.001344	-0.000860	-0.001716	-0.001056
-8.00	3.00	-0.000857	-0.001775	-0.002568	-0.003505	-0.002105	-0.001329	-0.000546	-0.001344	-0.000860	-0.001716	-0.001056
-8.00	3.00	-0.000706	-0.000873	-0.001283	-0.001049	-0.000578	-0.000578	-0.000522	-0.001283	-0.002282	-0.001542	-0.001720
-8.00	3.00	-0.000706	-0.000873	-0.001283	-0.001049	-0.000578	-0.000578	-0.000522	-0.001283	-0.002282	-0.001542	-0.001720
-10.60	3.00	-0.000395	-0.000138	-0.000617	-0.000681	-0.000595	-0.000595	-0.000526	-0.000526	-0.000526	-0.000526	-0.000526
-8.00	3.00	-0.000774	-0.000975	-0.000704	-0.001029	-0.000963	-0.000846	-0.000557	-0.000735	-0.000943	-0.001116	-0.001336

Force and Moment Summary

h/Dc =	5.87	3.51	2.33	2.33	3.51	5.86	5.87	3.51	2.32	2.32	3.51	5.88
Balance	AL/T =	-0.128	-0.285	-0.552	-0.527	-0.275	-0.131	-0.281	-0.534	-0.531	-0.276	-0.142
Balance	AL/T =	-0.124	-0.277	-0.505	-0.496	-0.260	-0.128	-0.269	-0.520	-0.539	-0.253	-0.145
Balance	AM/TDe =	0.116	0.357	0.533	0.508	0.305	0.200	0.213	0.535	0.566	0.359	0.288
Balance	AM/TDe =	0.156	0.357	0.692	0.634	0.416	0.262	0.300	0.699	0.705	0.456	0.328

Configuration: 2C-8-0-DW Jet-Induced Pressure Increments Run 191B

	13	14	15	16	17	18
Point	5.85	3.51	3.51	5.84	5.86	3.51
h/De	224.18	224.25	217.62	217.60	231.69	232.73
Total Thrust =	5.98	5.98	5.50	5.50	6.48	6.50
NPR Front =	6.00	6.00	6.34	6.34	5.54	5.54
NPR Aft =	ACP	ACP	ACP	ACP	ACP	ACP
X-loc	Y-loc	Y-loc	Y-loc	Y-loc	Y-loc	Y-loc
15.00	0.00	-0.000700	-0.001041	-0.000698	-0.000228	-0.000659
13.00	0.00	-0.000808	-0.001149	-0.000861	-0.000437	-0.000855
11.00	0.00	-0.000766	-0.001184	-0.001009	-0.000541	-0.000863
9.00	0.00	-0.000863	-0.001273	-0.001254	-0.000744	-0.000863
7.00	0.00	-0.000929	-0.000929	-0.001207	-0.001914	-0.001230
5.85	0.00	-0.001052	-0.000882	-0.002318	-0.001548	-0.001984
5.50	0.00	-0.001162	-0.001181	-0.002191	-0.001303	-0.001902
4.80	0.00	-0.001252	-0.001319	-0.003989	-0.001662	-0.001847
3.20	0.00	-0.001436	-0.002626	-0.005935	-0.001931	-0.001469
2.85	0.00	-0.001229	-0.002682	-0.005935	-0.002804	-0.002897
2.50	0.00	-0.001435	-0.003834	-0.009094	-0.001775	-0.003134
2.15	0.00	-0.001447	-0.004318	-0.009432	-0.001742	-0.003343
1.50	0.00	-0.001600	-0.002066	-0.005213	-0.000736	-0.002158
0.75	0.00	-0.000247	-0.003750	-0.006702	-0.000474	-0.001659
0.00	0.00	-0.000584	-0.006646	-0.007013	-0.001299	-0.001767
0.00	0.00	-0.000230	-0.004508	-0.004548	-0.000945	-0.003157
-1.50	0.00	-0.000481	-0.004357	-0.002443	-0.001647	-0.004589
-2.15	0.00	-0.000694	-0.003351	-0.004158	-0.002459	-0.001340
-2.85	0.00	-0.000527	-0.000442	-0.004433	-0.002680	-0.003752
-3.20	0.00	-0.000393	-0.002156	-0.005207	-0.001716	-0.00586
-4.80	0.00	-0.001040	-0.007526	-0.001507	-0.001738	-0.008986
-5.15	0.00	-0.003283	-0.012583	-0.005204	-0.002470	-0.01663
-5.50	0.00	-0.001579	-0.005157	-0.004144	-0.002075	-0.001488
-5.85	0.00	-0.002073	-0.003910	-0.003040	-0.001705	-0.00903
-6.50	0.00	-0.002232	-0.003031	-0.002601	-0.001459	-0.005202
-7.25	0.00	-0.001726	-0.003031	-0.002381	-0.001427	-0.00934
-8.00	0.00	-0.001774	-0.002482	-0.002406	-0.001130	-0.003396
-8.75	0.00	-0.001364	-0.002177	-0.002023	-0.001165	-0.002869
-9.50	0.00	-0.001355	-0.002324	-0.001825	-0.001141	-0.002948
-10.25	0.00	-0.001324	-0.002139	-0.001568	-0.001248	-0.00557
-11.00	0.00	-0.000939	-0.001428	-0.001435	-0.001345	-0.001756
-12.00	0.00	-0.000872	-0.001469	-0.001409	-0.001134	-0.000496
-13.50	0.00	-0.000988	-0.001644	-0.001212	-0.001211	-0.000540
4.00	0.80	-0.003393	-0.004946	-0.001851	-0.004433	-0.005009
11.00	1.50	-0.000953	-0.001196	-0.001299	-0.001498	-0.000971
9.00	1.50	-0.001792	-0.001926	-0.001997	-0.000998	-0.001554
7.00	1.50	-0.001193	-0.001537	-0.001324	-0.001849	-0.001347
5.50	1.50	-0.001252	-0.001410	-0.003522	-0.001579	-0.001455
4.00	1.50	-0.001742	-0.003971	-0.006835	-0.001736	-0.001956
2.50	1.50	-0.001304	-0.002621	-0.002516	-0.000410	-0.001639
1.00	1.50	-0.000990	-0.002694	-0.003245	-0.000230	-0.001753
0.50	1.50	-0.000743	-0.005190	-0.007213	-0.001557	-0.001736
-1.50	1.50	-0.000119	-0.002459	-0.002753	-0.002045	-0.001540
-2.50	1.50	-0.000148	-0.003184	-0.007368	-0.002220	-0.001428
-4.00	1.50	-0.002051	-0.006722	-0.004058	-0.001841	-0.001228
-6.50	1.50	-0.001844	-0.004840	-0.002905	-0.001545	-0.001035
-8.00	1.50	-0.001433	-0.003492	-0.002233	-0.001156	-0.000673
-10.50	1.50	-0.001061	-0.002581	-0.001791	-0.001277	-0.000675
-12.00	1.50	-0.000752	-0.001766	-0.001650	-0.001486	-0.000383
-13.50	1.50	-0.000781	-0.001435	-0.001704	-0.001086	-0.000367
9.00	3.00	-0.002638	-0.004971	-0.002788	-0.001324	-0.002768
7.00	3.00	-0.002194	-0.003511	-0.002311	-0.001438	-0.002334
5.50	3.00	-0.001601	-0.002311	-0.001616	-0.001396	-0.002034
4.00	3.00	-0.001435	-0.003937	-0.006116	-0.001080	-0.002038
2.50	3.00	-0.001184	-0.003482	-0.002252	-0.000461	-0.001806
1.50	3.00	-0.000862	-0.002029	-0.004309	-0.000878	-0.001802
0.00	3.00	-0.000448	-0.001019	-0.004071	-0.002010	-0.001548
-1.50	3.00	-0.002051	-0.006722	-0.004058	-0.001841	-0.001548
-2.50	3.00	-0.000737	-0.007134	-0.007854	-0.002281	-0.001227
-4.00	3.00	-0.000737	-0.007134	-0.007854	-0.002281	-0.001227
-5.50	3.00	-0.000737	-0.007134	-0.007854	-0.002281	-0.001227
-6.50	3.00	-0.001433	-0.002492	-0.002233	-0.001156	-0.000673

Force and Moment Summary

	5.85	3.51	3.51	5.84	5.86	3.51
Balance	h/De =	-0.115	-0.262	-0.133	-0.107	-0.256
Pressure	Al/T =	-0.111	-0.235	-0.139	-0.107	-0.229
Balance	Al/T =	0.119	0.353	0.272	-0.018	0.202
Pressure	AM/TDe =	0.137	0.408	0.327	-0.004	0.211
	AM/TDe =					

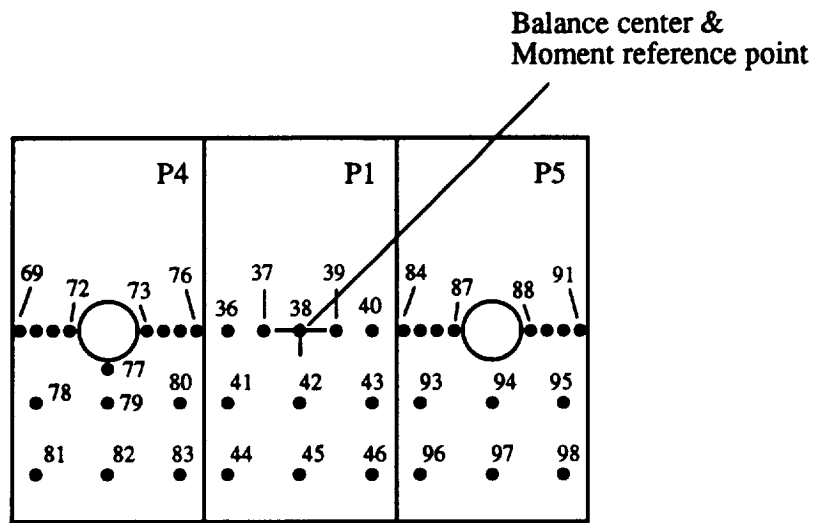

Figure 54. Configuration 2C\_8\_0\_12/8;  $D_e = 1.697$  in.,  $A_{jet} = 2.26$  in.<sup>2</sup>.

Pressure Orifice Locations and Weighting Factors

Conf. # 2C\_8\_0\_12/8

Distance from balance center to moment reference point,  $X_0 = 0$

Orif. #	Mom. arm	Sta. y	$\Delta$ .Area	Sta. x
69	5.85	0	0.634	5.85
70	5.5	0	0.683	5.5
71	5.15	0	0.683	5.15
72	4.8	0	0.619	4.8
73	3.2	0	0.619	3.2
74	2.85	0	0.683	2.85
75	2.5	0	0.683	2.5
76	2.15	0	0.634	2.15
77	4	0.8	1.238	4
78	5.5	1.5	3.19	5.5
79	4	1.5	3.825	4
80	2.5	1.5	3.19	2.5
81	5.5	3	4.375	5.5
82	4	3	5.25	4
83	2.5	3	4.375	2.5
36	1.5	0	1.313	1.5
37	0.75	0	1.125	0.75
38	0	0	1.125	0
39	-0.75	0	1.125	-0.75
40	-1.5	0	1.313	-1.5
41	1.5	1.5	3.75	1.5
42	0	1.5	4.5	0
43	-1.5	1.5	3.75	-1.5
44	1.5	3	4.375	1.5
45	0	3	5.25	0
46	-1.5	3	4.375	-1.5
84	-2.15	0	0.634	-2.15
85	-2.5	0	0.683	-2.5
86	-2.85	0	0.683	-2.85
87	-3.2	0	0.619	-3.2
88	-4.8	0	0.619	-4.8
89	-5.15	0	0.683	-5.15
90	-5.5	0	0.683	-5.5
91	-5.85	0	0.634	-5.85
93	-2.5	1.5	3.19	-2.5
94	-4	1.5	5.062	-4
95	-5.5	1.5	3.19	-5.5
96	-2.5	3	4.375	-2.5
97	-4	3	5.25	-4
98	-5.5	3	4.375	-5.5

Configuration: 2C-8-0-12/8 Jet-Induced Pressure Increments Run 192

Point	h/Dm =	11.77	8.83	5.87	4.70	3.53	2.36	1.15
Total Thrust =	NPR Front =	1.98	1.98	2.01	2.01	2.01	2.01	2.01
X-loc	Y-loc	ΔCp	ΔCp	ΔCp	ΔCp	ΔCp	ΔCp	ΔCp
5.85	0.00	-0.00118	-0.000683	-0.000826	-0.001872	-0.003188	-0.005693	-0.006222
5.50	0.00	-0.000841	-0.001184	-0.001192	-0.002434	-0.004340	-0.006603	-0.006412
5.15	0.00	-0.001311	-0.001244	-0.002074	-0.003520	-0.005107	-0.006859	-0.007569
4.80	0.00	-0.002644	-0.001866	-0.002247	-0.003131	-0.005046	-0.007365	-0.007547
3.20	0.00	-0.001579	-0.002181	-0.001158	-0.000605	-0.000403	-0.002570	-0.016634
2.85	0.00	-0.001100	-0.001352	-0.000419	-0.001444	-0.000967	-0.013285	-0.034546
2.50	0.00	-0.000815	-0.000851	-0.001012	-0.001842	-0.005544	-0.016360	-0.044431
2.15	0.00	-0.000621	-0.000151	-0.000778	-0.001186	-0.003223	-0.015871	-0.051633
1.50	0.00	-0.000350	-0.000107	-0.001572	-0.002281	-0.003335	-0.004248	-0.047833
0.75	0.00	-0.000152	-0.000290	-0.002320	-0.005193	-0.007291	-0.012915	-0.024487
0.00	0.00	-0.000163	-0.000453	-0.002773	-0.004474	-0.010207	-0.018398	-0.059837
-0.75	0.00	-0.000401	-0.000834	-0.000834	-0.003869	-0.004507	-0.006763	-0.003542
-1.50	0.00	-0.000325	-0.000010	-0.000957	-0.000692	-0.000795	-0.000788	-0.047798
-2.15	0.00	-0.000574	-0.000086	-0.000132	-0.002403	-0.005517	-0.017022	-0.049654
-2.50	0.00	-0.000396	-0.000921	-0.002076	-0.002938	-0.007582	-0.016045	-0.044254
-2.85	0.00	-0.001137	-0.001510	-0.002234	-0.003732	-0.005353	-0.013983	-0.034139
-3.20	0.00	-0.001259	-0.001933	-0.002132	-0.004078	-0.001290	-0.004886	-0.019814
-4.80	0.00	-0.002123	-0.002060	-0.003246	-0.004012	-0.006537	-0.007886	-0.009264
-5.15	0.00	-0.001681	-0.001374	-0.002407	-0.002800	-0.004655	-0.006676	-0.007477
-5.50	0.00	-0.001605	-0.000814	-0.001887	-0.002312	-0.004339	-0.005356	-0.006560
4.00	0.80	-0.002135	-0.003029	-0.001369	-0.001955	-0.003671	-0.005325	-0.006657
5.50	1.50	-0.001592	-0.000735	-0.000842	-0.013008	-0.017568	-0.021878	-0.017344
2.50	1.50	-0.000735	-0.000808	-0.002761	-0.006370	-0.009306	-0.004456	-0.005346
2.50	1.50	-0.000336	-0.000380	-0.001431	-0.001332	-0.006371	-0.015125	-0.016723
1.50	1.50	-0.000228	-0.000493	-0.001872	-0.001332	-0.006371	-0.017497	-0.042566
0.00	1.50	-0.000371	-0.000081	-0.002025	-0.003172	-0.007949	-0.015865	-0.051383
-1.50	1.50	-0.000310	-0.000168	-0.001033	-0.001441	-0.002228	-0.010482	-0.048135
-2.50	1.50	-0.000213	-0.000102	-0.001242	-0.001991	-0.003926	-0.010962	-0.025143
-4.00	1.50	-0.000213	-0.000102	-0.001242	-0.001991	-0.003926	-0.010962	-0.025143
-5.50	1.50	-0.001341	-0.000610	-0.002000	-0.002515	-0.003926	-0.005539	-0.008538
5.50	3.00	-0.000759	-0.000566	-0.001789	-0.002417	-0.003131	-0.004683	-0.006235
4.00	3.00	-0.005931	-0.005975	-0.006051	-0.005034	-0.005951	-0.006356	-0.006456
2.50	3.00	-0.000421	-0.000631	-0.001604	-0.001924	-0.005466	-0.013116	-0.029724
1.50	3.00	-0.000371	-0.000539	-0.000100	-0.001038	-0.000744	-0.004942	-0.038633
0.00	3.00	-0.000371	-0.000610	-0.000555	-0.003513	-0.004956	-0.010587	-0.038346
-1.50	3.00	-0.000457	-0.000631	-0.001486	-0.000666	-0.003600	-0.006514	-0.036990
-2.50	3.00	-0.001341	-0.000610	-0.002000	-0.002515	-0.003926	-0.005539	-0.008538
-4.00	3.00	-0.000559	-0.000753	-0.002676	-0.004016	-0.006058	-0.008927	-0.008497
-5.50	3.00	-0.000559	-0.000753	-0.002676	-0.004016	-0.006058	-0.008927	-0.008497

Force and Moment Summary

Balance	h/Dm =	11.77	8.83	5.87	4.70	3.53	2.36	1.15
Pressure	ΔL/T =	-0.006	-0.008	-0.015	-0.030	-0.065	-0.137	-0.347
Balance	ΔL/T =	-0.020	-0.019	-0.028	-0.031	-0.057	-0.120	-0.297
Pressure	ΔM/TDe =	0.088	0.033	0.007	0.000	0.049	0.098	0.105
Pressure	ΔM/TDe =	-0.017	-0.017	-0.007	-0.008	-0.008	-0.005	-0.012





Configuration: 2C-8-0-12/8 Jet-Induced Pressure Increments Run 194

Point	1	2	3	4	5	6	7
Total Thrust =	17.72	11.83	8.84	5.88	4.70	3.53	2.35
NPR Front =	221.14	221.06	220.94	221.11	221.14	221.08	221.12
NPR Aft =	5.93	5.93	5.92	5.92	5.92	5.92	5.92
X-loc	5.95	5.94	5.94	5.95	5.95	5.94	5.95
Y-loc	ACP	ACP	ACP	ACP	ACP	ACP	ACP
h/D <sub>e</sub> =	0.00	-0.000646	-0.000690	-0.000743	-0.000819	-0.001374	-0.002497
Balance	0.00	-0.000868	-0.000738	-0.000763	-0.000987	-0.001834	-0.003229
AL/T =	0.00	-0.000913	-0.000788	-0.001027	-0.001149	-0.002191	-0.004920
Pressure	4.80	0.00	-0.001317	-0.001593	-0.001781	-0.002131	-0.003042
Balance	3.20	0.00	-0.000630	-0.000784	-0.000873	-0.000677	-0.000627
AL/T =	2.85	0.00	-0.000394	-0.000547	-0.000433	-0.000578	-0.000325
Pressure	2.50	0.00	-0.000341	-0.000640	-0.000416	-0.000549	-0.000372
Balance	2.15	0.00	-0.000363	-0.000252	-0.000271	-0.000693	-0.001111
AL/T =	1.50	0.00	-0.000557	-0.000213	-0.000185	-0.001406	-0.002251
Pressure	0.75	0.00	-0.00047	-0.000210	-0.000187	-0.000809	-0.003446
Balance	0.00	0.00	-0.00014	-0.000130	-0.000541	-0.00237	-0.002315
AL/T =	-0.75	0.00	-0.00047	-0.000200	-0.000695	-0.00374	-0.001568
Pressure	-1.50	0.00	-0.00018	-0.000234	-0.000670	-0.001349	-0.000519
Balance	-2.15	0.00	-0.00200	-0.00156	-0.000814	-0.00887	-0.002161
AL/T =	-2.85	0.00	-0.00406	-0.00392	-0.000924	-0.001859	-0.002025
Pressure	-3.20	0.00	-0.00251	-0.00402	-0.000789	-0.001285	-0.001172
Balance	-4.80	0.00	-0.00579	-0.00660	-0.001018	-0.001197	-0.000404
AL/T =	-5.15	0.00	-0.01552	-0.01628	-0.001874	-0.002525	-0.003368
Pressure	-5.50	0.00	-0.01006	-0.00868	-0.001229	-0.01924	-0.002175
Balance	-4.85	0.00	-0.00807	-0.00758	-0.001033	-0.01574	-0.002167
AL/T =	4.50	0.00	-0.00902	-0.001797	-0.001348	-0.001385	-0.001471
Pressure	4.00	0.00	-0.00917	-0.000977	-0.000896	-0.005087	-0.011651
Balance	2.50	1.50	-0.00452	-0.000745	-0.000487	-0.001924	-0.004200
AL/T =	2.50	1.50	-0.00178	-0.000463	-0.000432	-0.000095	-0.000553
Pressure	1.50	1.50	-0.00262	-0.000161	-0.000267	-0.000446	-0.001057
Balance	0.00	1.50	-0.00066	-0.000151	-0.000546	-0.000689	-0.001506
AL/T =	-1.50	1.50	-0.00066	-0.000151	-0.000538	-0.001073	-0.000332
Pressure	-2.50	1.50	-0.00008	-0.00006	-0.000510	-0.001172	-0.001869
Balance	-4.00	1.50	-0.00098	-0.000622	-0.000510	-0.001493	-0.001909
AL/T =	-5.50	3.00	-0.00378	-0.00379	-0.003435	-0.000978	-0.001944
Pressure	4.00	3.00	-0.00359	-0.00349	-0.00378	-0.00423	-0.002917
Balance	2.50	3.00	-0.00328	-0.00388	-0.00378	-0.00423	-0.003139
AL/T =	1.50	3.00	-0.00289	-0.00388	-0.00378	-0.00423	-0.003139
Pressure	0.00	3.00	-0.00423	-0.00317	-0.000568	-0.000332	-0.001845
Balance	-1.50	3.00	-0.00369	-0.00274	-0.000860	-0.001247	-0.000305
AL/T =	-4.00	3.00	-0.001091	-0.000422	-0.000367	-0.001493	-0.001909
Pressure	-4.00	3.00	-0.00237	-0.000489	-0.000838	-0.001789	-0.002898
Balance	-5.50	3.00	-0.000237	-0.000489	-0.000838	-0.001789	-0.002898

Force and Moment Summary

h/D <sub>e</sub> =	17.72	11.83	8.84	5.88	4.70	3.53	2.35
Balance	AL/T =	-0.019	-0.012	-0.014	-0.022	-0.039	-0.069
Pressure	AL/T =	-0.012	-0.013	-0.017	-0.020	-0.024	-0.031
Balance	Δh/TDe =	0.049	0.042	0.042	0.029	0.026	0.013
Pressure	Δh/TDe =	-0.010	-0.012	-0.004	0.005	-0.001	-0.011

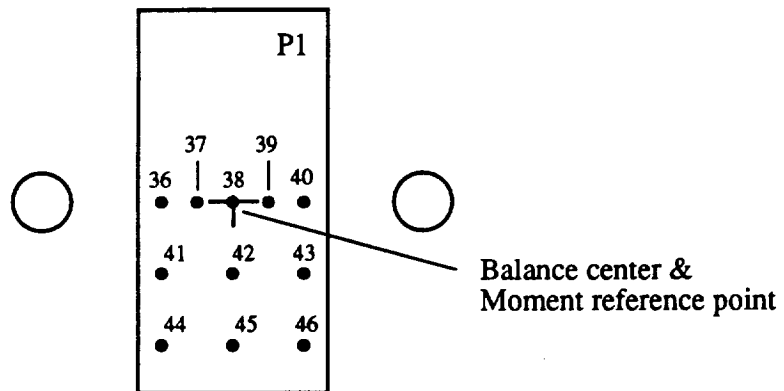

Figure 55. Configuration 2C\_8\_0\_4/8;  $D_e = 1.697$  in.,  $A_{jet} = 2.26$  in.<sup>2</sup>.

## Pressure Orifice Locations and Weighting Factors

Conf. # 2C\_8\_0\_4/8

Distance from balance center to moment reference point,  $X_0 = 0$

Orif. #	Mom. arm	Sta. y	$\Delta$ .Area	Sta. x
36	1.5	0	1.313	1.5
37	0.75	0	1.125	0.75
38	0	0	1.125	0 -0.1
39	-0.75	0	1.125	-0.75
40	-1.5	0	1.313	-1.5
41	1.5	1.5	3.75	1.5
42	0	1.5	4.5	0 -0.1
43	-1.5	1.5	3.75	-1.5
44	1.5	3	4.375	1.5
45	0	3	5.25	0 -0.1
46	-1.5	3	4.375	-1.5

Configuration: 2C-8-0-4/8 Jet-Induced Pressure Increments Run 195

Point	1	2	3	4	5	6	7
h/De =	17.67	8.83	5.89	4.71	3.52	2.34	1.17
Total Thrust =	52.25	52.54	52.27	52.14	51.97	51.70	51.92
NPR Front =	2.07	2.06	2.05	2.05	2.05	2.03	2.04
NPR Aft =	1.98	2.00	2.00	1.99	1.99	1.99	1.99
X-loc	ACP	ACP	ACP	ACP	ACP	ACP	ACP
1.50	0.00	-0.000278	-0.000450	0.000457	0.002206	0.001667	-0.030422
0.75	0.00	-0.000368	-0.000148	0.001256	0.002575	0.007520	0.021418
0.00	0.00	-0.000179	-0.000035	0.001704	0.003855	0.009386	0.023500
-0.75	0.00	-0.000209	0.000049	0.002558	0.002575	0.005086	0.012379
-1.50	0.00	-0.000368	0.000232	-0.000531	0.002057	0.002448	-0.005042
1.50	1.50	-0.000199	-0.000198	0.000045	0.000837	0.000889	0.001652
0.00	1.50	-0.000338	0.000489	-0.002474	0.004906	0.008040	0.022905
-1.50	1.50	-0.000422	-0.000306	0.000323	0.000782	-0.000235	-0.005168
1.50	3.00	-0.000139	-0.000642	-0.000025	0.000359	0.000350	-0.003194
0.00	3.00	-0.000283	-0.000292	0.000263	0.003486	0.004407	0.017104
-1.50	3.00	-0.000258	-0.000178	0.000273	-0.000359	0.000075	-0.005710

Force and Moment Summary

Balance h/De =	17.67	8.83	5.89	4.71	3.52	2.34	1.17
Pressure AL/T =	-0.002	-0.001	0.004	0.009	0.019	0.040	-0.015
Balance AM/TDe =	-0.010	-0.010	-0.016	-0.039	-0.018	-0.044	0.003
Pressure AN/TDe =	0.000	-0.001	-0.001	0.001	0.001	0.010	-0.052
Pressure AN/TDe =	0.000	-0.001	-0.001	0.001	0.001	0.010	0.010

Configuration: 2C-g-0-4/8 Jet-Induced Pressure Increments Run 196

Point	1	2	3	4	5	6
h/De =	8.84	5.90	4.73	3.54	2.35	1.76
Total Thrust =	137.44	137.40	137.37	137.32	137.34	137.32
NPR Front =	4.00	4.00	4.00	4.00	4.00	4.00
NPR Aft =	4.04	4.04	4.04	4.03	4.03	4.03
X-loc	Y-loc	ΔCp	ΔCp	ΔCp	ΔCp	ΔCp
1.50	0.00	-0.000257	0.000599	0.000796	0.002159	0.003926
0.75	0.00	-0.000204	0.001136	0.001851	0.005735	0.018354
0.00	0.00	-0.000011	0.001143	0.002000	0.005820	0.025093
-0.75	0.00	0.000085	0.000491	0.001616	0.004519	0.014229
1.50	0.00	-0.000202	0.000140	-0.000486	-0.000100	-0.000514
1.50	1.50	-0.000300	0.000338	0.000497	0.001055	0.001891
0.00	1.50	-0.000091	-0.000015	0.002493	0.005451	0.020524
-1.50	1.50	-0.000338	0.000019	-0.000070	-0.000406	-0.001087
1.50	3.00	-0.000055	0.000057	0.000267	0.001673	0.001743
0.00	3.00	-0.000242	0.000302	0.001705	0.003429	0.013798
-1.50	3.00	-0.000234	-0.000735	-0.000355	-0.000208	-0.0003743

Force and Moment Summary

	h/De =	h/De =	h/De =	h/De =	h/De =	h/De =
Balance	8.84	5.90	4.73	3.54	2.35	1.76
AL/T =	-0.002	0.000	0.003	0.012	0.042	0.057
Pressure	AL/T =	-0.001	0.006	0.016	0.047	0.067
Balance	ΔM/TDe =	-0.013	-0.030	-0.041	-0.038	-0.046
Pressure	ΔM/TDe =	0.000	0.001	0.001	0.003	0.005
Balance	ΔM/TDe =	0.000	0.001	0.001	0.003	0.005
Pressure	ΔM/TDe =	0.000	0.001	0.001	0.003	0.005

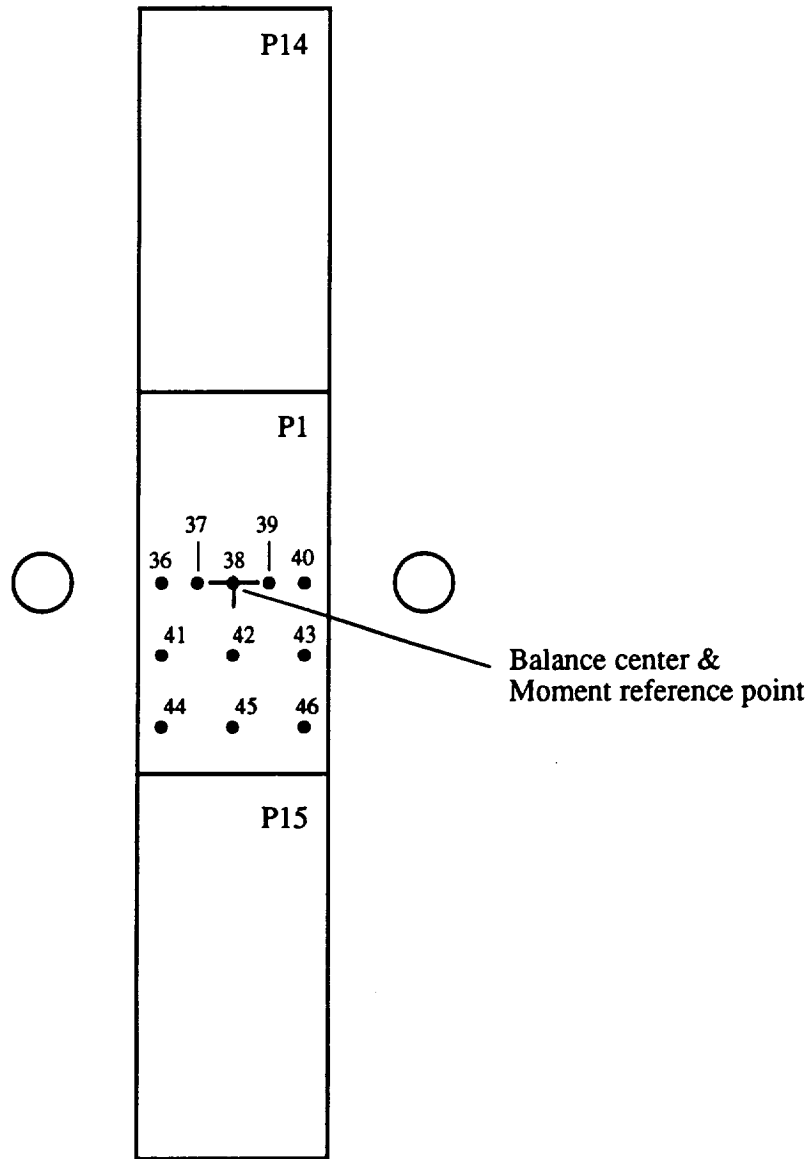

Figure 56. Configuration 2C\_8\_0\_4/24;  $D_e = 1.697$  in.,  $A_{jet} = 2.26$  in.<sup>2</sup>.

## Pressure Orifice Locations and Weighting Factors

Conf. # 2C\_8\_0\_4/24

Distance from balance center to moment reference point,  $X_o = 0$

Orif. #	Mom. arm	Sta. y	$\Delta$ .Area	Sta. x
36	1.5	0	1.313	1.5
37	0.75	0	1.125	0.75
38	0	0	1.125	0
39	-0.75	0	1.125	-0.75
40	-1.5	0	1.313	-1.5
41	1.5	1.5	3.75	1.5
42	0	1.5	4.5	0
43	-1.5	1.5	3.75	-1.5
44	1.5	3	4.375	1.5
45	0	3	5.25	0
46	-1.5	3	4.375	-1.5



Configuration: 2C-8-0-4/24  
 Jet-Induced Pressure Increments  
 Run 197

Point	1	2	3	4	5	6	7
h/De =	8.85	5.87	4.68	3.52	2.36	1.76	1.17
Total Thrust =	52.35	52.27	52.19	52.11	52.13	52.13	52.11
RPR Front =	2.04	2.04	2.04	2.04	2.04	2.04	2.04
RPR Aft =	2.01	2.01	2.01	2.01	2.01	2.01	2.01
X-loc	Y-loc	ACP	ACP	ACP	ACP	ACP	ACP
1.50	0.00	0.00064	0.000845	0.000796	0.00065	-0.006318	-0.046229
0.75	0.00	0.00055	0.001321	0.003170	0.004754	0.012673	0.007841
0.00	0.00	0.000392	0.000929	0.003353	0.008172	0.026910	0.043202
-0.75	0.00	0.000298	0.001724	0.002816	0.006009	0.017387	0.019110
-1.50	0.00	-0.000337	0.000745	0.001125	0.001694	-0.030339	-0.018895
1.50	1.50	-0.000332	0.000899	0.001139	0.001056	-0.06941	-0.021612
0.00	1.50	0.000094	0.001406	0.002831	0.007524	0.024853	0.041796
-1.50	1.50	-0.000015	0.000626	0.000164	0.000334	-0.004983	-0.021403
1.50	3.00	0.000010	0.000223	0.001179	0.001081	-0.051102	-0.019416
0.00	3.00	-0.000352	0.000705	0.003268	0.006767	0.022049	0.037136
-1.50	3.00	-0.000511	-0.000134	0.000229	-0.000384	-0.008142	-0.020857

Force and Moment Summary

h/De =	8.85	5.87	4.68	3.52	2.36	1.76	1.17
Balance AL/T =	-0.005	0.010	0.016	0.028	0.067	0.044	-0.082
Pressure AL/T =	-0.001	0.005	0.012	0.022	0.039	0.015	-0.044
Balance AH/TDe =	0.101	0.081	0.077	0.087	0.054	0.054	0.050
Pressure AH/TDe =	0.000	0.000	0.001	0.001	-0.000	-0.001	-0.003

Configuration: 2C-8-0-4/24 Jet-Induced Pressure Increments  
Run 198A

Point	1	2	3	4	5	6
h/De =	8.84	5.88	4.71	3.54	2.34	1.76
Total Thrust =	136.45	135.94	136.50	136.58	136.64	136.60
NPR Front =	3.98	3.96	3.98	3.99	3.99	3.99
NPR Aft =	4.01	4.01	4.00	4.00	4.00	4.00
X-loc	Y-loc	ΔCp	ΔCp	ΔCp	ΔCp	ΔCp
1.50	0.00	-0.000101	0.000246	0.000871	0.000523	-0.001908
0.75	0.00	-0.000002	-0.000288	0.002713	0.004107	0.013173
0.00	0.00	-0.000013	0.000458	0.002547	0.006075	0.024946
-0.75	0.00	-0.000329	0.000873	0.001541	0.005200	0.015752
-1.50	0.00	0.000185	0.000122	0.000304	0.000578	0.000110
1.50	1.50	-0.000335	0.000569	0.000748	0.000392	-0.001720
0.00	1.50	-0.000181	0.000988	0.001959	0.004336	0.023757
-1.50	1.50	-0.000051	0.000136	0.000251	-0.000766	-0.003206
1.50	3.00	-0.000369	-0.000621	0.000015	-0.000837	-0.004335
0.00	3.00	-0.000181	-0.000225	0.001200	0.003196	0.018397
-1.50	3.00	-0.000369	-0.000260	0.000354	0.000015	-0.004609

Force and Moment Summary

Balance h/De =	8.84	5.88	4.71	3.54	2.34	1.76
Balance AL/T =	-0.005	0.000	0.006	0.014	0.050	0.070
Pressure AL/T =	-0.001	0.001	0.007	0.012	0.045	0.038
Balance AM/TDe =	0.024	0.018	0.018	0.012	0.016	0.004
Pressure AM/TDe =	-0.000	-0.000	0.000	-0.001	0.001	-0.000

Jet-Induced Pressure Increments  
 Configuration: 2C-8-0-4/24 Run 198B

Point	7	8	9	10
h/De =	2.34	3.52	4.70	5.89
Total Thrust =	222.10	222.10	222.04	221.93
NPR Front =	5.95	5.95	5.95	5.94
NPR Aft =	5.95	5.95	5.95	5.95
X-loc	Y-loc	ACP	ACP	ACP
1.50	0.00	-0.002917	0.002236	0.000777
0.75	0.00	0.017576	0.007125	0.001884
0.00	0.00	0.032142	0.008644	0.003047
-0.75	0.00	0.017140	0.005833	0.002389
-1.50	0.00	-0.002868	0.001997	0.000735
1.50	1.50	-0.004178	0.002383	0.000526
0.00	1.50	0.035279	0.008440	0.002211
-1.50	1.50	-0.004127	0.001672	0.000609
1.50	3.00	-0.005186	0.000493	-0.000019
0.00	3.00	0.029901	0.006283	0.001727
-1.50	3.00	-0.004492	0.000066	-0.000267

Force and Moment Summary

Balance	h/De =	2.34	3.52	4.70	5.89
Pressure	Al/T =	0.118	0.032	0.010	-0.001
Balance	Al/T =	0.069	0.026	0.007	0.001
Pressure	AM/TDe =	-0.001	0.001	0.008	0.012
Balance	AM/TDe =	-0.001	0.001	0.000	-0.000

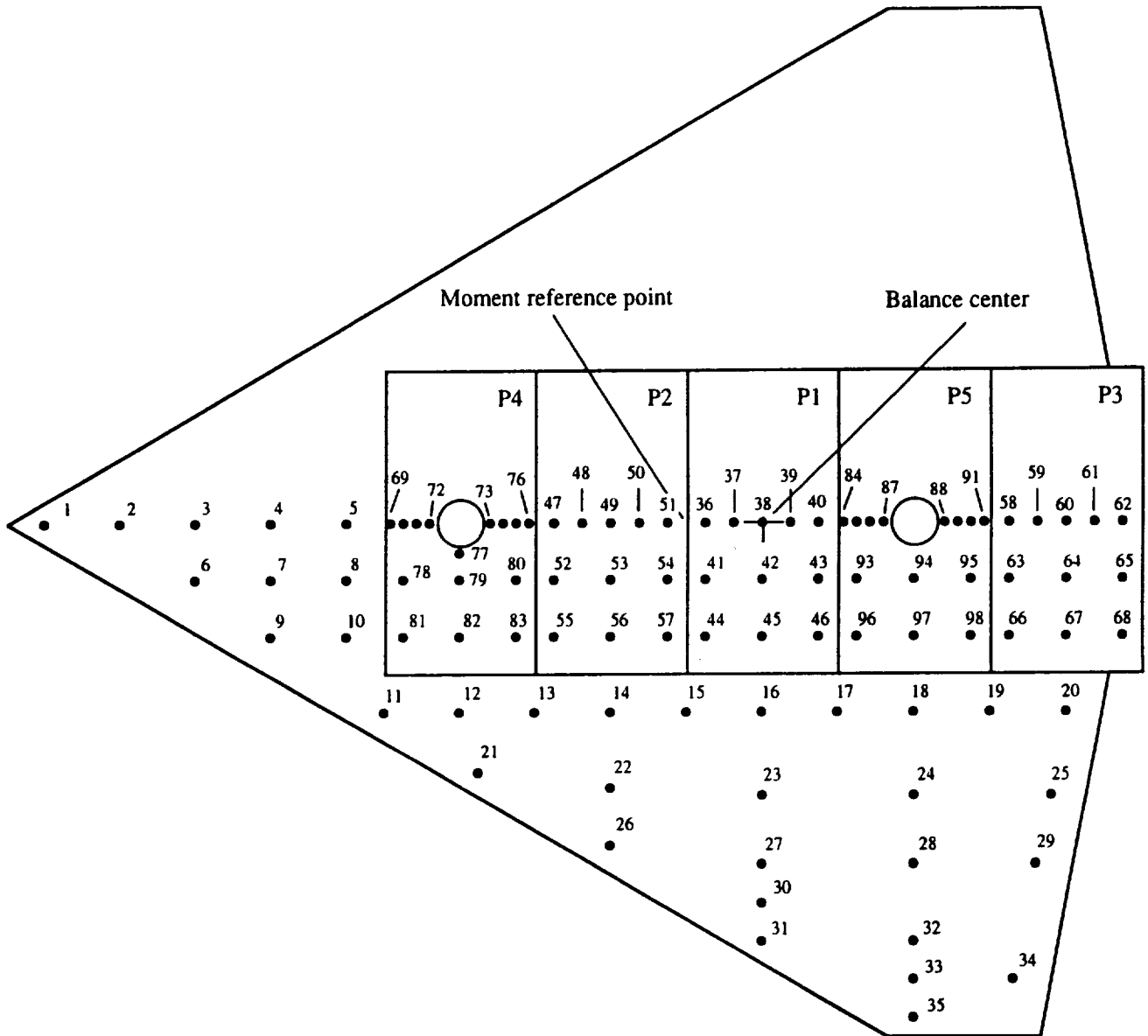

Figure 57. Configuration 2C\_12\_0\_DW;  $D_e = 1.697$  in.,  $A_{jet} = 2.26$  in.<sup>2</sup>.

Pressure Orifice Locations and Weighting Factors

Conf. # 2C\_12\_0\_DW

Distance from balance center to moment reference point,  $X_0 = 2$

Orif. #	Mom. arm	Sta. y	$\Delta$ .Area	Sta. x
1	16.6	0	2.3	17
2	14.86	0	6.918	15
3	13	0	3	13
4	11	0	3	11
5	9	0	3	9
6	13	1.5	8.546	13
7	11	1.5	6	11
8	9	1.5	6	9
9	10.87	3	7.166	11
10	9	3	7	9
11	8.14	5	8.91	8
12	6	5	8	6
13	4	5	8	4
14	2	5	8	2
15	0	5	8	0
16	-2	5	8	-2
17	-4	5	8	-4
18	-6	5	8	-6
19	-8	5	8	-8
20	-9.91	5	8.06	-10
21	5.06	6.6	7.302	5.5
22	2	7	16	2
23	-2	7	16	-2
24	-6	7	16	-6
25	-9.31	7	10.484	-9.6
26	1.235	8.5	9.904	2
27	-2	9	12	-2
28	-6	9	16	-6
29	-9.11	9	8.908	-9.2
30	-2	10	8	-2
31	-2.84	11	8.376	-2
32	-6	11	12	-6
33	-6	12	8	-6
34	-8.86	12	12.005	-8.6
35	-6.17	13	6.883	-6
69	7.85	0	0.634	7.85
70	7.5	0	0.683	7.5
71	7.15	0	0.683	7.15
72	6.8	0	0.619	6.8
73	5.2	0	0.619	5.2
74	4.85	0	0.683	4.85
75	4.5	0	0.683	4.5
76	4.15	0	0.634	4.15
77	6	0.8	1.238	6
78	7.5	1.5	3.19	7.5
79	6	1.5	3.825	6

Conf. # 2C\_12\_0\_DW, continued

Orif. #	Mom. arm	Sta. y	Δ.Area	Sta. x
80	4.5	1.5	3.19	4.5
81	7.5	3	4.375	7.5
82	6	3	5.25	6
83	4.5	3	4.375	4.5
47	3.5	0	1.313	3.5
48	2.75	0	1.125	2.75
49	2	0	1.125	2
50	1.25	0	1.125	1.25
51	0.5	0	1.313	0.5
52	3.5	1.5	3.75	3.5
53	2	1.5	4.5	2
54	0.5	1.5	3.75	0.5
55	3.5	3	4.375	3.5
56	2	3	5.25	2
57	0.5	3	4.375	0.5
36	-0.5	0	1.313	-0.5
37	-1.25	0	1.125	-1.25
38	-2	0	1.125	-2
39	-2.75	0	1.125	-2.75
40	-3.5	0	1.313	-3.5
41	-0.5	1.5	3.75	-0.5
42	-2	1.5	4.5	-2
43	-3.5	1.5	3.75	-3.5
44	-0.5	3	4.375	-0.5
45	-2	3	5.25	-2
46	-3.5	3	4.375	-3.5
84	-4.15	0	0.634	-4.15
85	-4.5	0	0.683	-4.5
86	-4.85	0	0.683	-4.85
87	-5.2	0	0.619	-5.2
88	-6.8	0	0.619	-6.8
89	-7.15	0	0.683	-7.15
90	-7.5	0	0.683	-7.5
91	-7.85	0	0.634	-7.85
93	-4.5	1.5	3.19	-4.5
94	-6	1.5	5.062	-6
95	-7.5	1.5	3.19	-7.5
96	-4.5	3	4.375	-4.5
97	-6	3	5.25	-6
98	-7.5	3	4.375	-7.5
58	-8.5	0	1.313	-8.5
59	-9.25	0	1.125	-9.25
60	-10	0	1.125	-10
61	-10.75	0	1.125	-10.75
62	-11.5	0	1.313	-11.5
63	-8.5	1.5	3.75	-8.5
64	-10	1.5	4.5	-10
65	-11.5	1.5	3.75	-11.5
66	-8.5	3	4.375	-8.5
67	-10	3	5.25	-10
68	-11.5	3	4.375	-11.5



Configuration: 2C-12-0-DM Jet-Induced Pressure Increments Run 200

Point	1	2	3	4	5	6	7
h/De =	17.65	11.77	8.82	5.87	4.70	3.52	2.35
Total Thrust =	137.78	137.86	137.64	137.29	137.23	137.17	137.06
NPR Front =	4.04	4.04	4.03	4.02	4.02	4.02	4.02
NPR Aft =	4.03	4.03	4.03	4.02	4.02	4.01	4.01
X-loc	ACP	ACP	ACP	ACP	ACP	ACP	ACP
Y-loc	ACP	ACP	ACP	ACP	ACP	ACP	ACP
17.00	0.00	0.000230	-0.000011	-0.000268	-0.000532	-0.001061	-0.001246
15.00	0.00	0.000152	-0.000236	-0.000530	-0.000656	-0.000991	-0.001680
13.00	0.00	0.000114	-0.000049	-0.000337	-0.000735	-0.001234	-0.002146
11.00	0.00	0.000092	-0.000084	-0.000337	-0.000735	-0.001234	-0.002146
9.00	0.00	0.000092	-0.000084	-0.000337	-0.000735	-0.001234	-0.002146
7.85	0.00	0.000263	-0.000483	-0.000785	-0.001024	-0.001394	-0.002513
7.50	0.00	0.000368	-0.000499	-0.000836	-0.000833	-0.001106	-0.002636
7.15	0.00	0.000404	-0.000470	-0.000951	-0.000754	-0.001110	-0.002549
6.80	0.00	0.000743	-0.001192	-0.001380	-0.001196	-0.001097	-0.001904
6.50	0.00	0.000951	-0.001091	-0.000921	-0.000834	-0.001473	-0.002525
4.85	0.00	0.000687	-0.000722	-0.000888	-0.001787	-0.002607	-0.004955
4.50	0.00	0.000473	-0.000808	-0.001239	-0.002517	-0.004054	-0.007839
4.15	0.00	0.000397	-0.000474	-0.001284	-0.002800	-0.004548	-0.010222
3.50	0.00	0.000236	-0.000339	-0.000632	-0.002107	-0.002647	-0.012857
2.75	0.00	0.000198	-0.000168	-0.000634	-0.002108	-0.003483	-0.003605
2.00	0.00	0.000207	-0.000107	-0.000352	-0.000634	-0.003483	-0.003605
1.25	0.00	0.000104	-0.000213	-0.001175	-0.002305	-0.003583	-0.005471
-0.50	0.00	0.000075	-0.000309	-0.000853	-0.002374	-0.003405	-0.004057
-2.00	0.00	0.000072	-0.000384	-0.000641	-0.001740	-0.002231	-0.002991
-3.75	0.00	0.000094	-0.000635	-0.000717	-0.001490	-0.003867	-0.005979
-4.15	0.00	0.000247	-0.000608	-0.001033	-0.001766	-0.003844	-0.005643
-4.50	0.00	0.000907	-0.000950	-0.000381	-0.000151	-0.000144	-0.001174
-5.20	0.00	0.000754	-0.001437	-0.002473	-0.004897	-0.005905	-0.003668
-6.15	0.00	0.000338	-0.000910	-0.000952	-0.002549	-0.004345	-0.003817
-7.50	0.00	0.000152	-0.000456	-0.001239	-0.002022	-0.004154	-0.003852
-8.50	0.00	0.000268	-0.000544	-0.001170	-0.002510	-0.003122	-0.003580
-8.50	0.00	0.000268	-0.000544	-0.001151	-0.002523	-0.002997	-0.003042
-9.25	0.00	0.000298	-0.000418	-0.001151	-0.002523	-0.002997	-0.003042
-10.00	0.00	0.000198	-0.000507	-0.000952	-0.001814	-0.002455	-0.002836
-10.75	0.00	0.000138	-0.000527	-0.000836	-0.001566	-0.002144	-0.002606
-11.50	0.00	0.000134	-0.000518	-0.000813	-0.001492	-0.002007	-0.002854
6.00	0.00	0.000744	-0.000554	-0.000866	-0.001947	-0.003434	-0.004133
13.00	1.50	0.000664	-0.000125	-0.000866	-0.000641	-0.000917	-0.001380
11.00	1.50	0.000015	-0.000124	-0.000896	-0.001332	-0.001581	-0.002388
9.00	1.50	0.000565	-0.000148	-0.000920	-0.001657	-0.001763	-0.001971
7.50	1.50	0.000203	-0.000123	-0.000888	-0.001882	-0.001674	-0.001542
6.00	1.50	0.000171	-0.000651	-0.002215	-0.002358	-0.003549	-0.002580
4.50	1.50	0.000196	-0.000289	-0.000794	-0.002474	-0.003463	-0.004456
3.50	1.50	0.000196	-0.000289	-0.000794	-0.002474	-0.003463	-0.004456
2.00	1.50	0.000196	-0.000289	-0.000794	-0.002474	-0.003463	-0.004456
0.50	1.50	0.000085	-0.000068	-0.000321	-0.000625	-0.001174	-0.001851
-2.00	1.50	0.000070	-0.000288	-0.000406	-0.000932	-0.001459	-0.002087
-3.50	1.50	0.000128	-0.000606	-0.000594	-0.001223	-0.004423	-0.005239
-4.50	1.50	0.000741	-0.002353	-0.003471	-0.012064	-0.016774	-0.015108
-6.00	1.50	0.000741	-0.002353	-0.003471	-0.012064	-0.016774	-0.015108
-7.50	1.50	0.000229	-0.000776	-0.001566	-0.002323	-0.004207	-0.004474
-8.50	1.50	0.000229	-0.000776	-0.001566	-0.002323	-0.004207	-0.004474
-10.00	1.50	0.000179	-0.000437	-0.000830	-0.001823	-0.002605	-0.004031
-11.50	1.50	0.000171	-0.000431	-0.000855	-0.001292	-0.002605	-0.004031
9.00	3.00	0.000021	-0.000172	-0.000898	-0.001285	-0.002058	-0.003878
7.50	3.00	0.000023	-0.000170	-0.000929	-0.001285	-0.002058	-0.003878
6.00	3.00	0.000323	-0.002933	-0.002795	-0.002829	-0.003131	-0.002110
4.50	3.00	0.000141	-0.000288	-0.000950	-0.002863	-0.004680	-0.006436
3.50	3.00	0.000085	-0.000068	-0.000917	-0.001710	-0.003764	-0.003443
2.00	3.00	0.000153	-0.000283	-0.000260	-0.001787	-0.001644	-0.0010851
0.50	3.00	0.000102	-0.000105	-0.000242	-0.001956	-0.001644	-0.0012316
-2.00	3.00	0.000102	-0.000105	-0.000242	-0.001956	-0.001644	-0.0012316
-3.50	3.00	0.000094	-0.000473	-0.000436	-0.001071	-0.004177	-0.002899
-4.50	3.00	0.000221	-0.000776	-0.001566	-0.003253	-0.004207	-0.004474

Force and Moment Summary

Balance	17.65	11.77	8.82	5.87	4.70	3.52	2.35
h/De =	17.65	11.77	8.82	5.87	4.70	3.52	2.35
Pressure	AL/T = -0.016	-0.035	-0.059	-0.130	-0.203	-0.318	-0.582
Balance	AM/TDe = -0.015	-0.034	-0.068	-0.136	-0.196	-0.293	-0.515
Pressure	AM/TDe = 0.018	0.044	0.050	0.124	0.230	0.304	0.595
Balance	AM/TDe = 0.018	0.044	0.050	0.124	0.230	0.304	0.595
Pressure	AM/TDe = 0.018	0.044	0.050	0.124	0.230	0.304	0.595



Jet-Induced Pressure Increments  
 Configuration: 2C-12-0-DW Run 201

Point	1	2	3	4	5	6	7
h/D <sub>e</sub>	17.67	11.80	8.86	5.90	4.73	3.54	2.94
Total Thrust =	223.12	223.12	222.88	222.68	222.58	222.19	223.20
NPR Front =	5.99	5.99	5.98	5.97	5.97	5.96	5.98
NPR Aft =	5.97	5.97	5.97	5.97	5.96	5.95	5.97
X-loc	ACP	ACP	ACP	ACP	ACP	ACP	ACP
Y-loc	ACP	ACP	ACP	ACP	ACP	ACP	ACP
17.00	0.000052	-0.000263	-0.000463	-0.000723	-0.000965	-0.000976	-0.001044
15.00	-0.000090	-0.000308	-0.000470	-0.000677	-0.000862	-0.001074	-0.001282
13.00	0.000101	-0.000298	-0.000432	-0.000607	-0.000812	-0.001027	-0.001187
11.00	-0.000184	-0.000343	-0.000449	-0.000798	-0.000876	-0.001155	-0.001337
9.00	0.000000	-0.000350	-0.000459	-0.000728	-0.000931	-0.001155	-0.001337
7.85	0.000000	-0.000459	-0.000584	-0.000728	-0.000892	-0.000947	-0.001155
7.50	0.000000	-0.000584	-0.000654	-0.000728	-0.000892	-0.000947	-0.001155
7.15	0.000000	-0.000654	-0.000728	-0.000892	-0.001072	-0.000931	-0.000979
6.80	0.000000	-0.000728	-0.000892	-0.001072	-0.001155	-0.000931	-0.000979
6.50	0.000000	-0.000892	-0.001072	-0.001155	-0.000931	-0.000931	-0.000931
6.20	0.000000	-0.001072	-0.001155	-0.000931	-0.000931	-0.000931	-0.000931
5.90	0.000000	-0.001155	-0.000931	-0.000931	-0.000931	-0.000931	-0.000931
5.60	0.000000	-0.001155	-0.000931	-0.000931	-0.000931	-0.000931	-0.000931
5.30	0.000000	-0.001155	-0.000931	-0.000931	-0.000931	-0.000931	-0.000931
5.00	0.000000	-0.001155	-0.000931	-0.000931	-0.000931	-0.000931	-0.000931
4.75	0.000000	-0.001155	-0.000931	-0.000931	-0.000931	-0.000931	-0.000931
4.50	0.000000	-0.001155	-0.000931	-0.000931	-0.000931	-0.000931	-0.000931
4.25	0.000000	-0.001155	-0.000931	-0.000931	-0.000931	-0.000931	-0.000931
4.00	0.000000	-0.001155	-0.000931	-0.000931	-0.000931	-0.000931	-0.000931
3.75	0.000000	-0.001155	-0.000931	-0.000931	-0.000931	-0.000931	-0.000931
3.50	0.000000	-0.001155	-0.000931	-0.000931	-0.000931	-0.000931	-0.000931
3.25	0.000000	-0.001155	-0.000931	-0.000931	-0.000931	-0.000931	-0.000931
3.00	0.000000	-0.001155	-0.000931	-0.000931	-0.000931	-0.000931	-0.000931
2.75	0.000000	-0.001155	-0.000931	-0.000931	-0.000931	-0.000931	-0.000931
2.50	0.000000	-0.001155	-0.000931	-0.000931	-0.000931	-0.000931	-0.000931
2.25	0.000000	-0.001155	-0.000931	-0.000931	-0.000931	-0.000931	-0.000931
2.00	0.000000	-0.001155	-0.000931	-0.000931	-0.000931	-0.000931	-0.000931
1.75	0.000000	-0.001155	-0.000931	-0.000931	-0.000931	-0.000931	-0.000931
1.50	0.000000	-0.001155	-0.000931	-0.000931	-0.000931	-0.000931	-0.000931
1.25	0.000000	-0.001155	-0.000931	-0.000931	-0.000931	-0.000931	-0.000931
1.00	0.000000	-0.001155	-0.000931	-0.000931	-0.000931	-0.000931	-0.000931
0.75	0.000000	-0.001155	-0.000931	-0.000931	-0.000931	-0.000931	-0.000931
0.50	0.000000	-0.001155	-0.000931	-0.000931	-0.000931	-0.000931	-0.000931
0.25	0.000000	-0.001155	-0.000931	-0.000931	-0.000931	-0.000931	-0.000931
0.00	0.000000	-0.001155	-0.000931	-0.000931	-0.000931	-0.000931	-0.000931

Force and Moment Summary  
 h/D<sub>e</sub> = 17.67  
 Balance AL/T = -0.023  
 Pressure AL/T = 0.030  
 Balance AM/TDe = 0.000  
 Pressure AM/TDe = 0.000

Configuration: 2C-12-0-DW Jet-Induced Pressure Increments Run 202

Point	1	2	3	4
h/D <sub>e</sub> =	5.90	4.71	3.54	2.37
Total Thrust =	52.07	51.75	51.64	51.55
NPR Front =	1.89	1.88	1.88	1.88
NPR Aft =	2.15	2.14	2.14	2.14
X-loc	ACP	ACP	ACP	ACP
Y-loc	ACP	ACP	ACP	ACP
17.00	0.00	-0.000213	-0.000743	-0.000909
15.00	0.00	-0.000436	-0.000703	-0.000934
13.00	0.00	-0.000901	-0.000822	-0.001029
11.00	0.00	-0.001417	-0.001052	-0.001404
9.00	0.00	-0.001417	-0.001052	-0.001404
7.85	0.00	-0.003046	-0.001765	-0.001209
7.50	0.00	-0.002207	-0.001671	-0.001205
7.15	0.00	-0.002732	-0.002110	-0.001474
6.80	0.00	-0.003448	-0.002899	-0.001961
5.20	0.00	-0.001195	-0.001296	-0.002631
4.85	0.00	-0.001211	-0.003523	-0.005160
4.50	0.00	-0.001334	-0.004279	-0.007535
4.15	0.00	-0.001529	-0.004113	-0.008667
3.50	0.00	-0.000369	-0.003152	-0.007357
2.75	0.00	-0.002748	-0.005042	-0.004088
2.00	0.00	-0.003431	-0.002669	-0.001318
1.25	0.00	-0.002254	-0.004942	-0.006924
0.50	0.00	-0.000813	-0.003432	-0.004933
-1.25	0.00	-0.002773	-0.007181	-0.010745
-2.00	0.00	-0.002748	-0.004812	-0.010799
-2.75	0.00	-0.003955	-0.005665	-0.010817
-3.50	0.00	-0.003750	-0.006839	-0.010966
-4.15	0.00	-0.003736	-0.006011	-0.010063
-4.85	0.00	-0.003927	-0.004827	-0.007272
-5.20	0.00	-0.003765	-0.004566	-0.005169
-6.80	0.00	-0.002633	-0.003593	-0.003948
-7.15	0.00	-0.002828	-0.003407	-0.003852
-7.85	0.00	-0.002773	-0.002815	-0.003565
-8.50	0.00	-0.002239	-0.002885	-0.004063
-9.25	0.00	-0.002039	-0.002639	-0.002952
-10.00	0.00	-0.001880	-0.002368	-0.003047
-10.75	0.00	-0.001830	-0.002238	-0.003012
-11.50	0.00	-0.001830	-0.002238	-0.003012
-13.00	1.50	-0.004695	-0.011107	-0.011439
-11.00	1.50	-0.001125	-0.001386	-0.002108
-7.50	1.50	-0.003876	-0.001479	-0.001314
-6.00	1.50	-0.004804	-0.005098	-0.006237
-4.50	1.50	-0.002012	-0.004825	-0.009839
-3.00	1.50	-0.004884	-0.003683	-0.006059
-1.50	1.50	-0.002214	-0.006006	-0.007447
0.50	1.50	-0.001140	-0.003407	-0.003495
-2.00	1.50	-0.001706	-0.002850	-0.006834
-4.50	1.50	-0.006812	-0.008219	-0.007050
-7.50	1.50	-0.006912	-0.008219	-0.007050
-10.50	1.50	-0.002837	-0.003482	-0.003636
-13.00	1.50	-0.002524	-0.003176	-0.004515
-11.00	3.00	-0.002005	-0.002639	-0.003158
-7.50	3.00	-0.001940	-0.002258	-0.003505
-6.00	3.00	-0.003764	-0.001448	-0.001454
-4.50	3.00	-0.003304	-0.001470	-0.001563
-3.00	3.00	-0.002350	-0.001228	-0.002866
-1.50	3.00	-0.001377	-0.000708	-0.007447
0.50	3.00	-0.002234	-0.006029	-0.007447
2.00	3.00	0.002698	0.000923	-0.000252
3.50	3.00	0.002598	0.000923	-0.000252
5.00	3.00	0.002274	0.002403	0.003857
6.50	3.00	-0.002209	-0.002101	-0.003472
8.00	3.00	-0.003341	-0.003850	-0.010742
9.50	3.00	-0.002837	-0.003482	-0.003636
11.00	3.00	-0.002837	-0.003482	-0.003636

Force and Moment Summary

Balance	5.90	4.71	3.54	2.37
Pressure	AL/T =	-0.154	-0.225	-0.332
Balance	AL/T =	-0.159	-0.215	-0.323
Pressure	AM/TDe =	0.279	0.370	0.404
Balance	AM/TDe =	0.245	0.354	0.468

Configuration: 2C-12-0-DW Jet-Induced Pressure Increments Run 203

Point	1	2	3	4	Point	1	2	3	4
h/De =	5.89	4.71	3.52	2.33	h/De =	5.89	4.71	3.52	2.33
Total Thrust =	52.01	51.85	51.96	51.96	Total Thrust =	52.01	51.85	51.96	51.96
NPR Front =	1.77	1.77	1.77	1.77	NPR Front =	1.77	1.77	1.77	1.77
NPR Aft =	2.26	2.26	2.26	2.26	NPR Aft =	2.26	2.26	2.26	2.26
X-loc	ACP	ACP	ACP	ACP	X-loc	ACP	ACP	ACP	ACP
Y-loc	ACP	ACP	ACP	ACP	Y-loc	ACP	ACP	ACP	ACP
0.00	-0.000193	-0.000338	-0.000526	-0.000601	-6.00	-0.003145	-0.004041	-0.005507	-0.009793
15.00	-0.000466	-0.000670	-0.000959	-0.001077	-7.50	-0.003145	-0.004041	-0.005507	-0.009793
3.00	-0.001091	-0.000851	-0.000760	-0.001037	-8.50	-0.002605	-0.003625	-0.006057	-0.006361
13.00	-0.001582	-0.001318	-0.001390	-0.001658	-10.00	-0.002206	-0.002720	-0.003793	-0.005506
7.00	-0.001582	-0.001318	-0.001390	-0.001658	-11.50	-0.002052	-0.002689	-0.003473	-0.004637
7.85	-0.002884	-0.003373	-0.001715	-0.005373	8.00	-0.001909	-0.002826	-0.002209	-0.005490
7.50	-0.001989	-0.003988	-0.001889	-0.004856	5.00	-0.001805	-0.002841	-0.003996	-0.005664
7.15	-0.001488	-0.003611	-0.002666	-0.004860	4.00	-0.001761	-0.002806	-0.005863	-0.013760
6.80	-0.002116	-0.003624	-0.003422	-0.004236	2.00	-0.002406	-0.001174	0.000333	-0.002705
5.20	-0.001167	-0.000655	-0.000960	-0.004660	0.00	-0.001250	-0.000851	0.000963	0.000372
4.85	-0.000021	-0.001481	-0.005310	-0.011374	5.00	-0.002882	-0.002702	-0.008137	-0.016876
4.50	-0.000242	-0.001880	-0.007153	-0.014970	4.00	-0.002882	-0.002702	-0.008137	-0.016876
4.15	-0.000611	-0.002051	-0.007208	-0.017390	5.00	-0.002643	-0.005473	-0.008554	-0.012785
3.50	-0.000968	-0.000686	-0.005862	-0.006836	8.00	-0.002519	-0.003313	-0.005108	-0.005098
2.75	-0.001413	-0.003210	-0.003085	-0.011194	-10.00	-0.002053	-0.002895	-0.003326	-0.006582
2.00	-0.001273	-0.005073	-0.004722	-0.003372	5.50	-0.000779	-0.001796	-0.003272	-0.005123
1.25	-0.001513	-0.004452	-0.009168	-0.014104	2.00	-0.000630	0.000507	0.000924	0.001485
0.50	-0.000928	-0.002809	-0.010056	-0.015027	-2.00	-0.002822	-0.004124	-0.006330	-0.011366
-0.50	-0.001393	-0.000561	-0.000485	-0.003848	-6.00	-0.002410	-0.003339	-0.004582	-0.003694
-1.25	-0.000932	-0.003726	-0.006237	-0.015713	-9.60	-0.002157	-0.002174	-0.002691	-0.007873
-2.00	-0.002321	-0.004367	-0.008601	-0.019900	-8.50	-0.000074	0.000557	0.000536	0.001990
-3.75	-0.003566	-0.005073	-0.010291	-0.020945	-2.00	-0.001855	-0.003517	-0.004985	-0.006791
-4.15	-0.003209	-0.005643	-0.010300	-0.019291	-9.20	-0.002222	-0.002100	-0.002095	-0.004423
-4.50	-0.003509	-0.005634	-0.007966	-0.012822	10.00	-0.002137	-0.002776	-0.003908	-0.005917
-4.85	-0.003695	-0.005093	-0.006642	-0.011639	11.00	-0.002356	-0.002711	-0.003013	-0.003599
-5.20	-0.003759	-0.004813	-0.005457	-0.012744	-6.00	-0.001801	-0.001786	-0.001891	-0.001594
-6.80	-0.002601	-0.003342	-0.004953	-0.007080	-6.00	-0.001761	-0.001691	-0.001876	-0.001916
-7.15	-0.002596	-0.003340	-0.004723	-0.006181	-8.60	-0.001280	-0.001533	-0.001479	-0.001608
-7.50	-0.002166	-0.003190	-0.004818	-0.004906	-6.00	-0.001691	0.000090	-0.002179	-0.002740
-8.50	-0.002372	-0.002769	-0.003618	-0.004682	Force and Moment Summary				
-9.25	-0.002372	-0.002769	-0.003618	-0.004682	Balance	h/De =	4.71	3.52	2.33
-10.00	-0.002071	-0.002424	-0.002764	-0.004118	Pressure	AL/T =	-0.165	-0.340	-0.582
-10.75	-0.002071	-0.002424	-0.002764	-0.004118	Balance	AL/T =	-0.189	-0.338	-0.617
-11.50	-0.001912	-0.002399	-0.002974	-0.004007	Pressure	AH/TDe =	0.237	0.303	0.424
6.00	-0.001912	-0.002399	-0.002974	-0.004007	Pressure	AH/TDe =	0.232	0.307	0.486
13.00	-0.002673	-0.002492	-0.01420	-0.004249					
11.00	-0.001671	-0.001518	-0.001902	-0.001608					
9.00	-0.001671	-0.001393	-0.001167	-0.005858					
7.50	-0.002905	-0.004012	-0.02173	-0.006629					
6.00	-0.004139	-0.006287	-0.008816	-0.015257					
4.50	-0.000708	-0.003169	-0.008894	-0.015257					
3.50	-0.000549	-0.000916	-0.005807	-0.016932					
2.00	-0.000404	-0.002979	-0.006542	-0.012354					
0.50	-0.001723	-0.001437	-0.001164	-0.006176					
-2.00	-0.003540	-0.004692	-0.009003	-0.020649					
-3.50	-0.002651	-0.006220	-0.010971	-0.019595					
-4.50	-0.003557	-0.006129	-0.005562	-0.011813					
-6.00	-0.005357	-0.006129	-0.005562	-0.011813					
-7.50	-0.002561	-0.003515	-0.004072	-0.006865					
-8.50	-0.002726	-0.003270	-0.004258	-0.005807					
-10.00	-0.002002	-0.002754	-0.003708	-0.005347					
-11.50	-0.001892	-0.002664	-0.003153	-0.004042					
11.00	-0.001557	-0.001403	-0.001321	-0.005073					
9.00	-0.002029	-0.003000	-0.004110	-0.005490					
7.50	-0.002629	-0.004220	-0.003744	-0.006532					
6.00	-0.008024	-0.007636	-0.007017	-0.007067					
4.50	-0.001281	-0.002790	-0.008789	-0.015265					
3.50	-0.000404	-0.002979	-0.006542	-0.012354					
2.00	-0.001178	-0.004102	-0.003708	-0.002838					
0.50	-0.001178	-0.004102	-0.003708	-0.002838					
-2.00	-0.001807	-0.001788	-0.001210	-0.005652					
-5.00	-0.002995	-0.004287	-0.008685	-0.019169					
-3.50	-0.003334	-0.005438	-0.009386	-0.017645					
-4.50	-0.002561	-0.003515	-0.004072	-0.006865					



Configuration: 2C-12-0-DW Jet-Induced Pressure Increments Run 205A

Point	1	2	3	4	5	6	7
h/D <sub>e</sub> =	5.87	4.71	3.52	2.35	8.85	11.79	8.83
Total Thrust =	138.05	137.89	137.86	137.80	137.68	138.19	137.06
NPR Front =	3.67	3.67	3.67	3.67	3.67	3.68	4.00
NPR Aft =	4.40	4.40	4.39	4.39	4.39	4.40	4.01
X-loc	ACP	ACP	ACP	ACP	ACP	ACP	ACP
Y-loc	ACP	ACP	ACP	ACP	ACP	ACP	ACP
Point	1	2	3	4	5	6	7
h/D <sub>e</sub> =	5.87	4.71	3.52	2.35	8.85	11.79	8.83
Total Thrust =	138.05	137.89	137.86	137.80	137.68	138.19	137.06
NPR Front =	3.67	3.67	3.67	3.67	3.67	3.68	4.00
NPR Aft =	4.40	4.40	4.39	4.39	4.39	4.40	4.01
X-loc	ACP	ACP	ACP	ACP	ACP	ACP	ACP
Y-loc	ACP	ACP	ACP	ACP	ACP	ACP	ACP
Point	1	2	3	4	5	6	7
h/D <sub>e</sub> =	5.87	4.71	3.52	2.35	8.85	11.79	8.83
Total Thrust =	138.05	137.89	137.86	137.80	137.68	138.19	137.06
NPR Front =	3.67	3.67	3.67	3.67	3.67	3.68	4.00
NPR Aft =	4.40	4.40	4.39	4.39	4.39	4.40	4.01
X-loc	ACP	ACP	ACP	ACP	ACP	ACP	ACP
Y-loc	ACP	ACP	ACP	ACP	ACP	ACP	ACP

Force and Moment Summary

Balance	4.71	3.52	2.35	8.85	11.79	8.83
Pressure	-0.149	-0.205	-0.272	-0.077	-0.049	-0.074
Balance	-0.156	-0.201	-0.245	-0.086	-0.049	-0.074
Pressure	0.209	0.312	0.428	0.126	0.166	0.108
Balance	0.209	0.312	0.428	0.126	0.166	0.108

Configuration: 2C-12-0-DW Jet-Induced Pressure Increments Run 205B

Point	8	9	10	11
h/Dw =	5.89	4.70	3.53	2.93
Total Thrust =	222.41	222.43	222.32	222.30
NPR Front =	5.67	5.67	5.66	5.66
NPR Aft =	6.47	6.47	6.46	6.46
X-loc	Y-loc	ACP	ACP	ACP
17.00	0.00	-0.000568	-0.000790	-0.000912
15.00	0.00	-0.000494	-0.000680	-0.000819
13.00	0.00	-0.000606	-0.000770	-0.000898
11.00	0.00	-0.000692	-0.000825	-0.01088
9.00	0.00	-0.000692	-0.000825	-0.01088
7.85	0.00	-0.001469	-0.000839	-0.01151
7.50	0.00	-0.001709	-0.001087	-0.01040
7.15	0.00	-0.001037	-0.001255	-0.001369
6.80	0.00	-0.001967	-0.001851	-0.001270
6.50	0.00	-0.000573	-0.00122	-0.000564
4.85	0.00	-0.001282	-0.001982	-0.002720
4.50	0.00	-0.001403	-0.002938	-0.002720
4.15	0.00	-0.001807	-0.003479	-0.006584
3.50	0.00	-0.000975	-0.001892	-0.004199
2.75	0.00	-0.000338	-0.000907	-0.001222
2.00	0.00	-0.001629	-0.003924	-0.003499
1.25	0.00	-0.001518	-0.02053	-0.007166
-1.25	0.00	-0.000963	-0.001662	-0.003906
-2.00	0.00	-0.000413	-0.000379	-0.002282
-2.75	0.00	-0.001516	-0.001856	-0.008775
-3.50	0.00	-0.002664	-0.004138	-0.008417
-4.15	0.00	-0.002043	-0.003723	-0.006579
-4.85	0.00	-0.000895	-0.000295	-0.000914
-5.80	0.00	-0.003817	-0.005104	-0.006360
-6.20	0.00	-0.002637	-0.003693	-0.004353
-7.15	0.00	-0.002283	-0.002890	-0.003800
-7.50	0.00	-0.002434	-0.002812	-0.004091
-8.50	0.00	-0.002113	-0.002375	-0.003220
-9.25	0.00	-0.003113	-0.002375	-0.003220
-10.00	0.00	-0.001762	-0.003397	-0.002858
-10.75	0.00	-0.001686	-0.001934	-0.002961
-11.50	0.00	-0.001586	-0.002082	-0.003138
16.00	0.80	-0.004757	-0.005778	-0.007854
13.00	1.50	-0.000642	-0.000778	-0.001107
11.00	1.50	-0.000881	-0.001454	-0.001564
9.00	1.50	-0.000947	-0.000847	-0.001179
7.50	1.50	-0.003044	-0.000925	-0.001121
6.00	1.50	-0.002554	-0.003955	-0.007149
4.50	1.50	-0.001432	-0.003211	-0.007064
3.00	1.50	-0.001432	-0.003211	-0.007064
2.00	1.50	-0.000439	-0.002584	-0.006287
0.50	1.50	-0.001222	-0.002840	-0.005310
-2.00	1.50	-0.001539	-0.004076	-0.002263
-3.50	1.50	-0.003603	-0.004244	-0.008193
-4.50	1.50	-0.007576	-0.00650	-0.014800
-5.00	1.50	-0.002168	-0.002850	-0.004509
-5.50	1.50	-0.002078	-0.002257	-0.002949
-6.50	1.50	-0.001728	-0.002589	-0.003049
-10.00	1.50	-0.001482	-0.002021	-0.002894
11.00	3.00	-0.001528	-0.001343	-0.001880
9.00	3.00	-0.001649	-0.001611	-0.001574
7.50	3.00	-0.003280	-0.003127	-0.003200
6.00	3.00	-0.001541	-0.004059	-0.007400
4.50	3.00	-0.000439	-0.002594	-0.006287
3.00	3.00	-0.000721	-0.000668	-0.002227
2.00	3.00	-0.000403	-0.001135	-0.005375
-0.50	3.00	-0.000403	-0.001135	-0.005375
-2.00	3.00	-0.000756	-0.001457	-0.003376
-3.50	3.00	-0.002344	-0.004277	-0.008561
-4.50	3.00	-0.002468	-0.002961	-0.004209

Force and Moment Summary

Point	8	9	10	11
Balance h/Dw =	5.89	4.70	3.53	2.93
Pressure AL/T =	222.41	222.43	222.32	222.30
Balance AM/TDe =	5.67	5.67	5.66	5.66
Pressure AM/TDe =	6.47	6.47	6.46	6.46

Configuration: 2C-12-0-DW Run 206

Point	1	2	3	4	5	6	7
h/De =	25.05	16.68	21.46	8.37	6.69	5.03	3.16
Total Thrust =	25.73	25.67	25.65	25.60	25.58	25.57	25.54
NPR Front =	1.00	1.00	1.00	1.00	1.00	1.00	1.00
NPR Aft =	1.98	1.98	1.98	1.98	1.98	1.98	1.98
X-loc	ACP	ACP	ACP	ACP	ACP	ACP	ACP
Y-loc	ACP	ACP	ACP	ACP	ACP	ACP	ACP
Point	1	2	3	4	5	6	7
h/De =	25.05	16.68	21.46	8.37	6.69	5.03	3.16
Total Thrust =	25.73	25.67	25.65	25.60	25.58	25.57	25.54
NPR Front =	1.00	1.00	1.00	1.00	1.00	1.00	1.00
NPR Aft =	1.98	1.98	1.98	1.98	1.98	1.98	1.98
X-loc	ACP	ACP	ACP	ACP	ACP	ACP	ACP
Y-loc	ACP	ACP	ACP	ACP	ACP	ACP	ACP

Force and Moment Summary

Balance	25.05	16.68	21.46	8.37	6.69	5.03	3.16
Pressure	-0.022	-0.036	-0.060	-0.137	-0.201	-0.331	-0.865
Balance	-0.035	-0.042	-0.067	-0.148	-0.216	-0.348	-0.874
Pressure	-0.045	-0.067	-0.091	-0.201	-0.288	-0.438	-1.197
Balance	-0.067	-0.091	-0.115	-0.261	-0.368	-0.538	-1.488
Pressure	-0.067	-0.091	-0.115	-0.261	-0.368	-0.538	-1.488

Configuration: 2C-12-0-DM Jet-Induced Pressure Increments Run 207

Point	2	3	4	5	6	7
h/D <sub>e</sub> =	25.05	16.67	12.47	8.30	6.66	4.97
Total Thrust =	68.18	67.95	67.79	67.59	67.55	67.44
NPR Front =	1.00	1.00	1.00	1.00	1.00	1.00
NPR Aft =	3.96	3.95	3.94	3.93	3.93	3.92
X-loc	Y-loc	ΔCP	ΔCP	ΔCP	ΔCP	ΔCP
17.00	0.00	0.000151	-0.000161	0.000040	-0.000414	-0.000320
15.00	0.00	0.000168	-0.000142	0.000000	-0.000406	-0.000325
13.00	0.00	0.000185	-0.000131	0.000015	-0.000406	-0.000359
11.00	0.00	0.000178	-0.000112	0.000017	-0.000420	-0.000809
9.00	0.00	0.000178	-0.000112	0.000017	-0.000420	-0.000809
7.85	0.00	0.000053	-0.000123	0.000020	-0.000385	-0.000552
7.50	0.00	0.000044	-0.000103	0.000018	-0.000393	-0.000583
7.15	0.00	0.000052	-0.000117	0.000014	-0.000377	-0.000555
6.80	0.00	0.000053	-0.000124	0.000015	-0.000367	-0.000514
5.20	0.00	0.000073	-0.000159	0.000020	-0.000355	-0.000485
4.85	0.00	0.000076	-0.000105	0.000023	-0.000344	-0.000444
4.50	0.00	0.000034	-0.000117	0.000021	-0.000321	-0.000234
4.15	0.00	0.000032	-0.000113	0.000018	-0.000288	-0.000188
3.50	0.00	0.000046	-0.000105	0.000019	-0.000267	-0.000167
2.75	0.00	0.000046	-0.000105	0.000019	-0.000267	-0.000167
2.00	0.00	0.000017	-0.000095	0.000019	-0.000245	-0.000135
1.25	0.00	0.000032	-0.000113	0.000018	-0.000234	-0.000167
0.50	0.00	0.000044	-0.000105	0.000020	-0.000234	-0.000167
-1.25	0.00	0.000051	-0.000124	0.000023	-0.000229	-0.000189
-2.00	0.00	0.000050	-0.000140	0.000024	-0.000228	-0.000200
-3.50	0.00	0.000177	-0.000300	0.000049	-0.000568	-0.000870
-4.15	0.00	0.000255	-0.000455	0.000058	-0.000795	-0.000847
-4.85	0.00	0.000373	-0.000560	0.000068	-0.001024	-0.001192
-5.20	0.00	0.000487	-0.000718	0.000088	-0.001351	-0.001436
-6.80	0.00	0.000194	-0.000353	0.000028	-0.000625	-0.000224
-7.15	0.00	0.000133	-0.000227	0.000027	-0.000404	-0.000171
-7.50	0.00	0.000131	-0.000239	0.000027	-0.000400	-0.000167
-7.85	0.00	0.000095	-0.000189	0.000028	-0.000315	-0.000638
-8.50	0.00	0.000095	-0.000189	0.000028	-0.000315	-0.000638
-9.25	0.00	0.000053	-0.000128	0.000021	-0.000281	-0.000634
-10.00	0.00	0.000053	-0.000128	0.000021	-0.000281	-0.000634
-10.75	0.00	0.000047	-0.000116	0.000025	-0.000255	-0.000555
-11.50	0.00	0.000047	-0.000116	0.000025	-0.000247	-0.000449
13.00	1.50	0.000201	-0.000120	0.000046	-0.000425	-0.000500
9.00	1.50	0.000244	-0.000142	0.000020	-0.000332	-0.000489
7.50	1.50	0.000066	-0.000148	0.000019	-0.000242	-0.000465
6.00	1.50	0.000048	-0.000151	0.000020	-0.000242	-0.000498
4.50	1.50	0.000053	-0.000130	0.000025	-0.000259	-0.000520
3.00	1.50	0.000036	-0.000128	0.000021	-0.000194	-0.000494
2.00	1.50	0.000023	-0.000101	0.000019	-0.000122	-0.000357
0.50	1.50	0.000030	-0.000122	0.000022	-0.000122	-0.000234
-0.50	1.50	0.000025	-0.000128	0.000023	-0.000128	-0.000234
-3.50	1.50	0.000101	-0.000220	0.000032	-0.000571	-0.000840
-4.50	1.50	0.000112	-0.000458	0.000018	-0.001988	-0.002750
-6.00	1.50	0.000097	-0.000140	0.000023	-0.000691	-0.000834
-7.50	1.50	0.000095	-0.000107	0.000027	-0.000646	-0.000732
-8.50	1.50	0.000101	-0.000178	0.000029	-0.000553	-0.000790
-10.00	1.50	0.000076	-0.000147	0.000028	-0.000528	-0.000765
11.00	3.00	0.000233	-0.000167	0.000025	-0.000786	-0.001039
7.50	3.00	0.000225	-0.000154	0.000029	-0.000887	-0.001428
6.00	3.00	0.001977	-0.000226	0.000392	-0.000798	-0.000999
4.50	3.00	0.001977	-0.000226	0.000392	-0.000798	-0.000999
3.00	3.00	0.000023	-0.000188	0.000047	-0.000292	-0.000292
2.00	3.00	0.000044	-0.000159	0.000019	-0.000517	-0.000803
0.50	3.00	0.000044	-0.000159	0.000019	-0.000647	-0.001005
-0.50	3.00	0.000053	-0.000130	0.000025	-0.000657	-0.000847
-2.00	3.00	0.000044	-0.000124	0.000024	-0.000620	-0.000551
-3.50	3.00	0.000044	-0.000126	0.000026	-0.000714	-0.000442
-4.50	3.00	0.000097	-0.000140	0.000037	-0.000691	-0.000834

Point	2	3	4	5	6	7
h/D <sub>e</sub> =	25.05	16.67	12.47	8.30	6.66	4.97
Total Thrust =	68.18	67.95	67.79	67.59	67.55	67.44
NPR Front =	1.00	1.00	1.00	1.00	1.00	1.00
NPR Aft =	3.96	3.95	3.94	3.93	3.93	3.92
X-loc	Y-loc	ΔCP	ΔCP	ΔCP	ΔCP	ΔCP
-6.00	0.00	0.000065	-0.000183	-0.000289	-0.000722	-0.001346
-7.50	3.00	0.000065	-0.000183	-0.000289	-0.000722	-0.001346
-8.50	3.00	0.000080	-0.000189	-0.000281	-0.000615	-0.002435
-10.00	3.00	0.000070	-0.000227	-0.000308	-0.000574	-0.002300
-11.50	3.00	0.000089	-0.000182	-0.000194	-0.000457	-0.001950
6.00	5.00	0.000244	-0.000140	0.000202	-0.000859	-0.001319
6.00	5.00	0.000265	-0.000116	0.000177	-0.000895	-0.001362
5.00	5.00	0.000267	-0.000123	0.000173	-0.000903	-0.001369
4.00	5.00	0.000250	-0.000127	0.000166	-0.000924	-0.001352
3.00	5.00	0.000244	-0.000127	0.000175	-0.000914	-0.001318
2.00	5.00	0.000208	-0.000135	0.000268	-0.000912	-0.000785
1.00	5.00	0.000208	-0.000135	0.000268	-0.000912	-0.000785
0.00	5.00	0.000208	-0.000133	0.000202	-0.000897	-0.001287
-1.00	5.00	0.000170	-0.000139	0.000175	-0.000805	-0.001107
-2.00	5.00	0.000146	-0.000146	0.000179	-0.000836	-0.001201
-3.00	5.00	0.000140	-0.000137	0.000175	-0.000847	-0.001024
-4.00	5.00	0.000185	-0.000108	0.000171	-0.000767	-0.000941
-5.00	5.00	0.000168	-0.000122	0.000126	-0.000529	-0.000684
-6.00	5.00	0.000195	-0.000120	0.000141	-0.000456	-0.001168
-7.00	5.00	0.000197	-0.000122	0.000116	-0.000626	-0.000552
-8.00	5.00	0.000185	-0.000129	0.000110	-0.000582	-0.000859
-9.00	5.00	0.000183	-0.000122	0.000103	-0.000412	-0.000846
-10.00	5.00	0.000138	-0.000133	0.000114	-0.000590	-0.001522
-11.00	5.00	0.000163	-0.000140	0.000089	-0.000502	-0.000644
-12.00	5.00	0.000149	-0.000148	0.000099	-0.000527	-0.001069
-13.00	5.00	0.000131	-0.000125	0.000108	-0.000433	-0.000997
-14.00	5.00	0.000097	-0.000135	0.000128	-0.000445	-0.001218
-15.00	5.00	0.000097	-0.000135	0.000128	-0.000445	-0.001218

Force and Moment Summary

Balance	25.05	16.67	12.47	8.30	6.66	4.97
ΔL/T =	0.020	-0.035	-0.059	-0.137	-0.193	-0.309
Pressure	0.021	-0.031	-0.039	-0.137	-0.191	-0.312
Balance	-0.020	-0.098	-0.094	-0.011	0.081	0.394
Pressure	0.061	0.069	0.080	0.137	0.271	0.599



Configuration: 2C-12-0-DM Run 208

Point	1	2	3	4	5	6
h/De =	24.98	16.70	12.47	8.30	6.64	4.96
Total Thrust =	113.10	112.85	112.77	112.77	112.67	112.67
NPR Front =	1.00	1.00	1.00	1.00	1.00	1.00
NPR Aft =	6.04	6.02	6.02	6.02	6.01	6.01
X-loc	ACP	ACP	ACP	ACP	ACP	ACP
Y-loc	ACP	ACP	ACP	ACP	ACP	ACP
Point	1	2	3	4	5	6
h/De =	24.98	16.70	12.47	8.30	6.64	4.96
Total Thrust =	113.10	112.85	112.77	112.77	112.67	112.67
NPR Front =	1.00	1.00	1.00	1.00	1.00	1.00
NPR Aft =	6.04	6.02	6.02	6.02	6.01	6.01
X-loc	ACP	ACP	ACP	ACP	ACP	ACP
Y-loc	ACP	ACP	ACP	ACP	ACP	ACP
Force and Moment Summary						
Balance	24.98	16.70	12.47	8.30	6.64	4.96
Pressure	Δh/T = -0.019	-0.033	-0.056	-0.125	-0.181	-0.272
Balance	Δh/T = -0.021	-0.035	-0.058	-0.144	-0.186	-0.279
Pressure	Δh/TDe = -0.080	-0.066	-0.048	0.013	0.085	0.321
Balance	Δh/TDe = 0.025	0.034	0.053	0.120	0.215	0.433

Configuration: 2C-12-0-DM  
Run 209

Point	1	2	3	4	5	6	7	8
h/De =	17.64	11.81	17.68	8.84	3.52	4.69	3.52	2.32
Total Thrust =	51.92	52.12	52.12	52.20	52.18	52.12	52.12	52.06
NPR Front =	2.01	2.02	2.01	2.02	2.01	2.01	2.01	2.01
NPR Aft =	2.01	2.01	2.01	2.01	2.01	2.01	2.01	2.00
X-loc	ACP	ACP	ACP	ACP	ACP	ACP	ACP	ACP
Y-loc	ACP	ACP	ACP	ACP	ACP	ACP	ACP	ACP
17.00	-0.000240	-0.000664	-0.000203	-0.000237	-0.000870	-0.000851	-0.001138	-0.001289
15.00	-0.000094	-0.000326	-0.000163	-0.000366	-0.000746	-0.000975	-0.001139	-0.001760
13.00	-0.000119	-0.000341	-0.000163	-0.000484	-0.000776	-0.001084	-0.001371	-0.002050
11.00	-0.000164	-0.000573	-0.000257	-0.000722	-0.001097	-0.001396	-0.001649	-0.002300
9.00	-0.000185	-0.000652	-0.000299	-0.000810	-0.001161	-0.001459	-0.001649	-0.002300
7.50	-0.000278	-0.000932	-0.000399	-0.001142	-0.001331	-0.001530	-0.001540	-0.002067
7.15	-0.000340	-0.000941	-0.000404	-0.000993	-0.001142	-0.001337	-0.001390	-0.001685
6.80	-0.000394	-0.001357	-0.000493	-0.001145	-0.000928	-0.000928	-0.000928	-0.000928
5.20	-0.000789	-0.001530	-0.001145	-0.001145	-0.000928	-0.000928	-0.000928	-0.000928
4.85	-0.000893	-0.000718	-0.001145	-0.001145	-0.000928	-0.000928	-0.000928	-0.000928
4.50	-0.000931	-0.000431	-0.000512	-0.000717	-0.000938	-0.001145	-0.001390	-0.001685
4.15	-0.000931	-0.000274	-0.000324	-0.000324	-0.000324	-0.000324	-0.000324	-0.000324
3.50	-0.000270	-0.000388	-0.000259	-0.000338	-0.000508	-0.000678	-0.000848	-0.001018
2.75	-0.000160	-0.000184	-0.000194	-0.000228	-0.000284	-0.000350	-0.000416	-0.000482
2.00	-0.000115	-0.000135	-0.000144	-0.000162	-0.000209	-0.000265	-0.000321	-0.000377
0.50	-0.000155	-0.000259	-0.000335	-0.000416	-0.000508	-0.000600	-0.000692	-0.000784
-1.25	-0.000060	-0.000259	-0.000335	-0.000416	-0.000508	-0.000600	-0.000692	-0.000784
-2.75	-0.000010	-0.000378	-0.000454	-0.000530	-0.000606	-0.000682	-0.000758	-0.000834
-3.50	-0.000040	-0.000388	-0.000464	-0.000540	-0.000616	-0.000692	-0.000768	-0.000844
-4.15	-0.000070	-0.000413	-0.000489	-0.000565	-0.000641	-0.000717	-0.000793	-0.000869
-4.50	-0.000090	-0.000438	-0.000514	-0.000590	-0.000666	-0.000742	-0.000818	-0.000894
-4.85	-0.000110	-0.000463	-0.000539	-0.000615	-0.000691	-0.000767	-0.000843	-0.000919
-5.20	-0.000135	-0.000488	-0.000564	-0.000640	-0.000716	-0.000792	-0.000868	-0.000944
-6.80	-0.000260	-0.000619	-0.000695	-0.000771	-0.000847	-0.000923	-0.000999	-0.001075
-7.15	-0.000325	-0.000690	-0.000766	-0.000842	-0.000918	-0.000994	-0.001070	-0.001146
-7.50	-0.000380	-0.000761	-0.000837	-0.000913	-0.000989	-0.001065	-0.001141	-0.001217
-7.85	-0.000445	-0.000832	-0.000908	-0.000984	-0.001060	-0.001136	-0.001212	-0.001288
-8.50	-0.000445	-0.000832	-0.000908	-0.000984	-0.001060	-0.001136	-0.001212	-0.001288
-9.25	-0.000445	-0.000832	-0.000908	-0.000984	-0.001060	-0.001136	-0.001212	-0.001288
-10.00	-0.000445	-0.000832	-0.000908	-0.000984	-0.001060	-0.001136	-0.001212	-0.001288
-10.75	-0.000445	-0.000832	-0.000908	-0.000984	-0.001060	-0.001136	-0.001212	-0.001288
-11.50	-0.000445	-0.000832	-0.000908	-0.000984	-0.001060	-0.001136	-0.001212	-0.001288
6.00	-0.000824	-0.002413	-0.001088	-0.000524	-0.001088	-0.000524	-0.001088	-0.000524
13.00	-0.000099	-0.000494	-0.000242	-0.001448	-0.000939	-0.000336	-0.001881	-0.004693
9.00	-0.000144	-0.000554	-0.000218	-0.001621	-0.001048	-0.000449	-0.002306	-0.004351
7.50	-0.000268	-0.000951	-0.000339	-0.002582	-0.001594	-0.000984	-0.003642	-0.005580
6.00	-0.000374	-0.001391	-0.000469	-0.003994	-0.002522	-0.001692	-0.005230	-0.007168
4.50	-0.000315	-0.000937	-0.000329	-0.002602	-0.001692	-0.001081	-0.003905	-0.005843
3.00	-0.000185	-0.000530	-0.000199	-0.001627	-0.001048	-0.000649	-0.002484	-0.004296
0.50	-0.000085	-0.000276	-0.000110	-0.000841	-0.000524	-0.000336	-0.001177	-0.002135
-0.50	-0.000045	-0.000145	-0.000050	-0.000419	-0.000234	-0.000149	-0.000480	-0.000921
-1.50	-0.000035	-0.000095	-0.000030	-0.000262	-0.000163	-0.000104	-0.000336	-0.000656
-2.50	-0.000020	-0.000050	-0.000015	-0.000163	-0.000104	-0.000065	-0.000234	-0.000465
-3.50	-0.000010	-0.000025	-0.000005	-0.000081	-0.000051	-0.000033	-0.000117	-0.000234
-4.50	-0.000005	-0.000013	-0.000004	-0.000041	-0.000026	-0.000016	-0.000051	-0.000102
-5.50	-0.000002	-0.000006	-0.000002	-0.000020	-0.000013	-0.000008	-0.000026	-0.000051
-6.50	-0.000001	-0.000003	-0.000001	-0.000010	-0.000006	-0.000004	-0.000013	-0.000026
-7.50	-0.000000	-0.000001	-0.000000	-0.000005	-0.000003	-0.000002	-0.000006	-0.000013
-8.50	-0.000000	-0.000000	-0.000000	-0.000002	-0.000001	-0.000000	-0.000003	-0.000006
-9.50	-0.000000	-0.000000	-0.000000	-0.000001	-0.000000	-0.000000	-0.000001	-0.000002
-10.50	-0.000000	-0.000000	-0.000000	-0.000000	-0.000000	-0.000000	-0.000000	-0.000001
-11.50	-0.000000	-0.000000	-0.000000	-0.000000	-0.000000	-0.000000	-0.000000	-0.000000
9.00	0.000000	0.000000	0.000000	0.000000	0.000000	0.000000	0.000000	0.000000
7.50	0.000000	0.000000	0.000000	0.000000	0.000000	0.000000	0.000000	0.000000
6.00	0.000000	0.000000	0.000000	0.000000	0.000000	0.000000	0.000000	0.000000
4.50	0.000000	0.000000	0.000000	0.000000	0.000000	0.000000	0.000000	0.000000
3.00	0.000000	0.000000	0.000000	0.000000	0.000000	0.000000	0.000000	0.000000
1.50	0.000000	0.000000	0.000000	0.000000	0.000000	0.000000	0.000000	0.000000
0.00	0.000000	0.000000	0.000000	0.000000	0.000000	0.000000	0.000000	0.000000
-1.50	0.000000	0.000000	0.000000	0.000000	0.000000	0.000000	0.000000	0.000000
-3.00	0.000000	0.000000	0.000000	0.000000	0.000000	0.000000	0.000000	0.000000
-4.50	0.000000	0.000000	0.000000	0.000000	0.000000	0.000000	0.000000	0.000000
-6.00	0.000000	0.000000	0.000000	0.000000	0.000000	0.000000	0.000000	0.000000
-7.50	0.000000	0.000000	0.000000	0.000000	0.000000	0.000000	0.000000	0.000000
-9.00	0.000000	0.000000	0.000000	0.000000	0.000000	0.000000	0.000000	0.000000
-11.00	0.000000	0.000000	0.000000	0.000000	0.000000	0.000000	0.000000	0.000000
11.00	0.000000	0.000000	0.000000	0.000000	0.000000	0.000000	0.000000	0.000000
9.00	0.000000	0.000000	0.000000	0.000000	0.000000	0.000000	0.000000	0.000000
7.50	0.000000	0.000000	0.000000	0.000000	0.000000	0.000000	0.000000	0.000000
6.00	0.000000	0.000000	0.000000	0.000000	0.000000	0.000000	0.000000	0.000000
4.50	0.000000	0.000000	0.000000	0.000000	0.000000	0.000000	0.000000	0.000000
3.00	0.000000	0.000000	0.000000	0.000000	0.000000	0.000000	0.000000	0.000000
1.50	0.000000	0.000000	0.000000	0.000000	0.000000	0.000000	0.000000	0.000000
0.00	0.000000	0.000000	0.000000	0.000000	0.000000	0.000000	0.000000	0.000000
-1.50	0.000000	0.000000	0.000000	0.000000	0.000000	0.000000	0.000000	0.000000
-3.00	0.000000	0.000000	0.000000	0.000000	0.000000	0.000000	0.000000	0.000000
-4.50	0.000000	0.000000	0.000000	0.000000	0.000000	0.000000	0.000000	0.000000
-6.00	0.000000	0.000000	0.000000	0.000000	0.000000	0.000000	0.000000	0.000000
-7.50	0.000000	0.000000	0.000000	0.000000	0.000000	0.000000	0.000000	0.000000
-9.00	0.000000	0.000000	0.000000	0.000000	0.000000	0.000000	0.000000	0.000000
-11.00	0.000000	0.000000	0.000000	0.000000	0.000000	0.000000	0.000000	0.000000

Force and Moment Summary

Point	1	2	3	4	5	6	7	8
h/De =	17.64	11.81	17.68	8.84	3.52	4.69	3.52	2.32
Balance	AL/T =	-0.027	-0.054	-0.031	-0.073	-0.135	-0.228	-0.426
Pressure	AL/T =	-0.024	-0.058	-0.031	-0.063	-0.127	-0.218	-0.398
Balance	AM/TDe =	-0.136	-0.047	-0.100	-0.037	-0.054	-0.088	-0.158
Pressure	AM/TDe =	-0.005	0.058	0.003	0.033	0.228	0.298	0.411

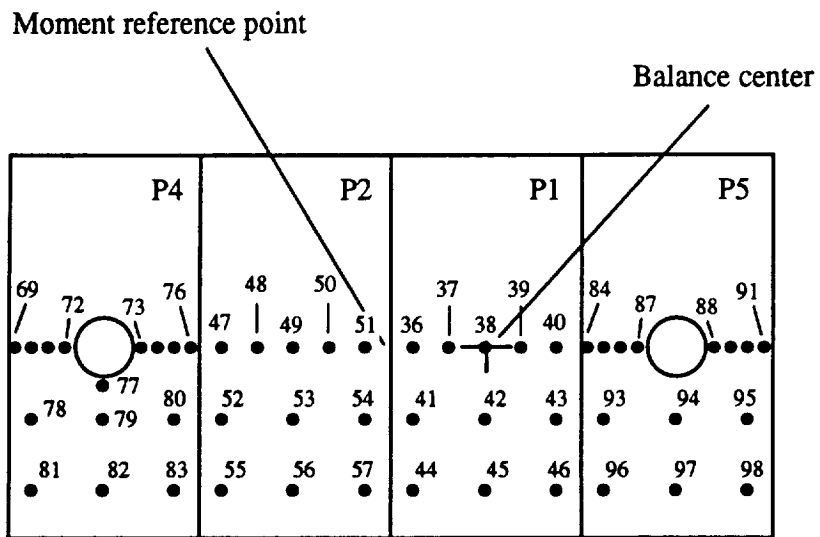

Figure 58. Configuration 2C\_12\_0\_16/8;  $D_e = 1.697$  in.,  $A_{jet} = 2.26$  in.<sup>2</sup>.

Pressure Orifice Locations and Weighting Factors

Conf. # 2C\_12\_0\_16/8

Distance from balance center to moment reference point,  $X_0 = 2$

Orif. #	Mom. arm	Sta. y	$\Delta$ .Area	Sta. x
69	7.85	0	0.634	7.85
70	7.5	0	0.683	7.5
71	7.15	0	0.683	7.15
72	6.8	0	0.619	6.8
73	5.2	0	0.619	5.2
74	4.85	0	0.683	4.85
75	4.5	0	0.683	4.5
76	4.15	0	0.634	4.15
77	6	0.8	1.238	6
78	7.5	1.5	3.19	7.5
79	6	1.5	3.825	6
80	4.5	1.5	3.19	4.5
81	7.5	3	4.375	7.5
82	6	3	5.25	6
83	4.5	3	4.375	4.5
47	3.5	0	1.313	3.5
48	2.75	0	1.125	2.75
49	2	0	1.125	2
50	1.25	0	1.125	1.25
51	0.5	0	1.313	0.5
52	3.5	1.5	3.75	3.5
53	2	1.5	4.5	2
54	0.5	1.5	3.75	0.5
55	3.5	3	4.375	3.5
56	2	3	5.25	2
57	0.5	3	4.375	0.5
36	-0.5	0	1.313	-0.5
37	-1.25	0	1.125	-1.25
38	-2	0	1.125	-2
39	-2.75	0	1.125	-2.75
40	-3.5	0	1.313	-3.5
41	-0.5	1.5	3.75	-0.5
42	-2	1.5	4.5	-2
43	-3.5	1.5	3.75	-3.5
44	-0.5	3	4.375	-0.5
45	-2	3	5.25	-2
46	-3.5	3	4.375	-3.5
84	-4.15	0	0.634	-4.15
85	-4.5	0	0.683	-4.5
86	-4.85	0	0.683	-4.85
87	-5.2	0	0.619	-5.2
88	-6.8	0	0.619	-6.8
89	-7.15	0	0.683	-7.15
90	-7.5	0	0.683	-7.5
91	-7.85	0	0.634	-7.85
93	-4.5	1.5	3.19	-4.5

Conf. # 2C\_12\_0\_16/8, continued

Orif. #	Mom. arm	Sta. y	$\Delta$ .Area	Sta. x
94	-6	1.5	5.062	-6
95	-7.5	1.5	3.19	-7.5
96	-4.5	3	4.375	-4.5
97	-6	3	5.25	-6
98	-7.5	3	4.375	-7.5

Jet-Induced Pressure Increments  
 Configuration: 2C-12-0-16/8 Run 210

Point	2	3	4	5	6	
h/D <sub>0</sub> =	8.86	5.89	4.73	3.55	2.35	
Total Thrust =	52.21	53.05	52.92	52.92	52.91	
NPR Front =	2.01	2.03	2.02	2.02	2.02	
NPR Aft =	2.01	2.03	2.03	2.03	2.03	
X-loc	Y-loc	ΔCP	ΔCP	ΔCP	ΔCP	
7.85	0.00	-0.000541	-0.000752	-0.001630	-0.002375	-0.003247
7.50	0.00	-0.000760	-0.001447	-0.001973	-0.002784	-0.003668
7.15	0.00	-0.001056	-0.001422	-0.002517	-0.003024	-0.003889
6.80	0.00	-0.001854	-0.003064	-0.004080	-0.004126	-0.004560
6.45	0.00	-0.003314	-0.001210	-0.001934	-0.002780	-0.004794
6.10	0.00	-0.001483	-0.002864	-0.004050	-0.006306	-0.009846
5.75	0.00	-0.001483	-0.003726	-0.005085	-0.007531	-0.012873
5.40	0.00	-0.000604	-0.003097	-0.005085	-0.008801	-0.013702
5.05	0.00	-0.000895	-0.002854	-0.004626	-0.008193	-0.014619
4.70	0.00	-0.003078	-0.001101	-0.002943	-0.006255	-0.013661
4.35	0.00	-0.001129	-0.000499	-0.000064	-0.001516	-0.009249
4.00	0.00	-0.001010	-0.001478	-0.003228	-0.003793	-0.001732
3.65	0.00	0.001085	0.003010	0.006358	0.010277	0.013341
3.30	0.00	0.001413	0.003392	0.006265	0.008892	0.017163
2.95	0.00	0.001059	0.002814	0.003150	0.004705	0.005687
2.60	0.00	0.001110	0.001199	0.001305	0.001678	0.006753
2.25	0.00	-0.000572	-0.000930	-0.003199	-0.005554	-0.012490
1.90	0.00	-0.000800	-0.002506	-0.004744	-0.008631	-0.013191
1.55	0.00	-0.001045	-0.002672	-0.005058	-0.008947	-0.013669
1.20	0.00	-0.001188	-0.003138	-0.004744	-0.008218	-0.012165
0.85	0.00	-0.001571	-0.002927	-0.004116	-0.006128	-0.009061
0.50	0.00	-0.002134	-0.001464	-0.001604	-0.003302	-0.005575
0.15	0.00	-0.001740	-0.003886	-0.003351	-0.004617	-0.005094
0.00	0.00	-0.000612	-0.001351	-0.002492	-0.003532	-0.003490
-0.35	0.00	-0.000522	-0.001278	-0.001992	-0.003461	-0.003033
-0.70	0.00	-0.000512	-0.000568	-0.001330	-0.000868	-0.003116
-1.05	0.00	-0.004841	-0.009168	-0.012109	-0.014468	-0.011616
-1.40	1.50	-0.000714	-0.001219	-0.002092	-0.002609	-0.003156
-1.75	1.50	-0.002057	-0.004977	-0.005914	-0.006455	-0.007125
-2.10	1.50	-0.001297	-0.003555	-0.005576	-0.008472	-0.013412
-2.45	1.50	-0.000438	-0.002388	-0.005142	-0.008306	-0.014200
-2.80	1.50	-0.000438	-0.002388	-0.005142	-0.008306	-0.014200
-3.15	1.50	-0.000970	-0.003367	-0.005633	-0.007217	-0.014256
-3.50	1.50	0.000433	0.003220	0.005687	0.009584	0.015000
-3.85	1.50	0.000572	0.000905	0.000059	-0.001766	-0.006895
-4.20	1.50	-0.000974	-0.002066	-0.004587	-0.008331	-0.014037
-4.55	1.50	-0.005247	-0.008671	-0.011099	-0.011725	-0.012515
-4.90	1.50	-0.005247	-0.008671	-0.011099	-0.011725	-0.012515
-5.25	1.50	-0.000870	-0.001439	-0.002031	-0.002321	-0.002983
-5.60	1.50	-0.000887	-0.001942	-0.002438	-0.002859	-0.003381
-5.95	3.00	-0.000667	-0.006278	-0.007731	-0.006526	-0.006061
-6.30	3.00	0.001284	-0.003101	-0.004243	-0.006835	-0.009735
-6.65	3.00	0.000970	0.003367	0.005633	0.007217	0.014256
-7.00	3.00	0.000000	0.000015	-0.000937	-0.002429	-0.008421
-7.35	3.00	0.000000	0.000015	-0.000937	-0.002429	-0.008421
-7.70	3.00	0.000448	0.003254	0.003591	0.007300	0.011580
-8.05	3.00	0.000398	-0.000367	0.000648	-0.002183	-0.007067
-8.40	3.00	-0.000632	-0.002016	-0.003611	-0.006442	-0.011275
-8.75	3.00	-0.000870	-0.001439	-0.002031	-0.002321	-0.002983
-9.10	3.00	-0.001288	-0.002716	-0.003773	-0.004259	-0.006463
-9.45	3.00	-0.001288	-0.002716	-0.003773	-0.004259	-0.006463

Force and Moment Summary

h/D <sub>0</sub> =	8.86	5.89	4.73	3.55	2.35
Balance	AL/T =	-0.033	-0.051	-0.084	-0.138
Pressure	AL/T =	-0.028	-0.046	-0.067	-0.090
Balance	AM/TD <sub>0</sub> =	-0.006	0.015	0.027	0.054
Pressure	ΔM/TD <sub>0</sub> =	0.001	0.010	0.015	0.017

Configuration: 2C-12-0-16/8 Jet-Induced Pressure Increments Run 211

Point	1	2	3	4	5
Total Thrust =	137.10	136.88	136.74	136.73	136.70
NPR Front =	3.97	3.95	3.98	3.95	3.95
NPR Aft =	3.98	3.98	3.98	3.98	3.98
X-loc	Y-loc	ACP	ACP	ACP	ACP
7.85	0.00	-0.003356	-0.001146	-0.001532	-0.002483
7.50	0.00	-0.004800	-0.001043	-0.002013	-0.003231
7.15	0.00	-0.008222	-0.001645	-0.002497	-0.002953
6.80	0.00	-0.015259	-0.002649	-0.003559	-0.004685
5.20	0.00	-0.003383	0.001076	0.001897	0.002049
4.85	0.00	-0.000550	-0.000822	-0.001615	-0.002642
4.50	0.00	-0.004420	-0.002027	-0.003263	-0.006356
4.15	0.00	-0.000758	-0.000699	-0.004439	-0.007779
3.50	0.00	-0.000138	-0.001049	-0.002934	-0.013182
2.75	0.00	-0.000036	-0.000078	-0.000566	-0.010983
2.00	0.00	0.000051	0.001394	0.002083	0.004004
1.25	0.00	0.000339	0.003734	0.005476	0.005855
0.50	0.00	-0.000062	0.003706	0.006164	0.009309
0.00	0.00	-0.000343	0.003709	0.005489	0.006940
-1.25	0.00	-0.000280	0.001081	0.001912	0.003595
-2.00	0.00	-0.000686	-0.000508	-0.000023	-0.002343
-2.75	0.00	-0.000657	-0.001324	-0.002932	-0.005537
-3.50	0.00	-0.000735	-0.002351	-0.004340	-0.007370
-4.15	0.00	-0.001015	-0.002720	-0.004218	-0.011354
-4.50	0.00	-0.001225	-0.003792	-0.003725	-0.007525
-4.85	0.00	-0.001434	-0.002233	-0.002866	-0.004461
-5.20	0.00	-0.001636	-0.001218	-0.001052	-0.01861
-6.80	0.00	-0.001799	-0.002341	-0.003421	-0.04074
-7.15	0.00	-0.001239	-0.001533	-0.002132	-0.002955
-7.50	0.00	-0.001148	-0.001383	-0.001747	-0.002836
-7.85	0.00	-0.001182	-0.001085	-0.001621	-0.01977
6.00	1.50	-0.002543	-0.016671	-0.18424	-0.15306
7.50	1.50	-0.006239	-0.001333	-0.002342	-0.002973
6.00	4.50	-0.001264	-0.004702	-0.005723	-0.007368
4.50	1.50	-0.000505	-0.002323	-0.004572	-0.008735
3.50	1.50	-0.000273	-0.001089	-0.003139	-0.007284
2.00	1.50	-0.000144	-0.002904	0.007107	0.007844
0.50	1.50	0.000434	0.002726	0.004284	0.006375
-2.00	1.50	-0.000585	-0.000523	-0.002057	-0.003162
-3.50	1.50	-0.000610	-0.002720	-0.004535	-0.007628
-4.50	1.50	-0.002214	-0.007541	-0.10583	-0.11932
-6.00	1.50	-0.002214	-0.007541	-0.10583	-0.11932
-7.50	1.50	-0.000983	-0.001280	-0.001572	-0.002100
7.50	3.00	-0.000494	-0.001695	-0.002542	-0.002971
6.00	3.00	-0.003782	-0.003641	-0.003860	-0.004348
4.50	3.00	-0.000856	-0.002567	-0.003976	-0.006743
3.50	3.00	-0.000144	0.002904	0.007107	0.007844
2.00	3.00	0.000049	0.001047	0.001804	0.000858
0.50	3.00	-0.000403	0.000880	0.003613	0.004680
-2.00	3.00	-0.000695	-0.000222	-0.001263	-0.002615
-3.50	3.00	-0.000778	-0.002474	-0.003943	-0.005973
-4.50	3.00	-0.000983	-0.001280	-0.001572	-0.002100
-6.00	3.00	-0.001085	-0.002375	-0.003040	-0.003922
-7.50	3.00	-0.001085	-0.002375	-0.003040	-0.003922

Force and Moment Summary

Balance	h/Da =	8.85	5.90	4.70	3.52	2.33
Pressure	AL/T =	-0.016	-0.032	-0.046	-0.076	-0.120
Balance	AL/T =	-0.023	-0.037	-0.050	-0.082	-0.100
Pressure	AM/TDa =	0.018	0.019	0.015	0.026	0.031
Balance	AM/TDa =	0.006	0.028	0.041	0.034	0.027

Jet-Induced Pressure Increments  
 Configuration: 2C-12-0-16/8 Run 212

Point	1	2	3	4	5
Total Thrust =	226.26	226.36	226.45	226.30	226.33
NFR Front =	5.95	5.95	5.95	5.95	5.95
NPR A/C =	6.03	6.03	6.03	6.02	6.02
X-loc	F-loc	ACP	ACP	ACP	ACP
7.85	0.00	-0.000454	-0.000754	-0.001336	-0.001573
7.50	0.00	-0.000473	-0.001005	-0.001282	-0.002371
7.15	0.00	-0.000580	-0.001632	-0.002575	-0.003455
6.80	0.00	-0.001261	-0.002228	-0.003671	-0.004353
5.20	0.00	-0.000461	0.000646	0.002104	0.001873
4.85	0.00	-0.000398	-0.000310	-0.000825	-0.001037
4.50	0.00	-0.000251	-0.001021	-0.002123	-0.005006
4.15	0.00	-0.000251	-0.001485	-0.002679	-0.006631
3.50	0.00	-0.000092	-0.000549	-0.002545	-0.005603
2.75	0.00	-0.000338	0.000181	-0.001197	-0.003091
2.00	0.00	-0.000019	0.000554	0.001622	0.002649
1.25	0.00	-0.000324	0.000583	0.002451	0.006315
0.50	0.00	-0.000419	0.000414	0.002791	0.007914
-0.50	0.00	-0.000623	0.000536	0.000862	0.003368
-1.25	0.00	-0.000792	-0.000377	-0.001041	-0.001694
-2.00	0.00	-0.000641	-0.001456	-0.002415	-0.004596
-2.75	0.00	-0.000847	-0.002052	-0.003450	-0.006425
-3.50	0.00	-0.000983	-0.002124	-0.003330	-0.006425
-4.15	0.00	-0.001170	-0.001988	-0.003005	-0.005112
-4.50	0.00	-0.001245	-0.002022	-0.002197	-0.003029
-4.85	0.00	-0.001413	-0.001527	-0.000939	-0.000467
-5.20	0.00	-0.001460	-0.002360	-0.002725	-0.003776
-5.80	0.00	-0.001220	-0.001707	-0.002062	-0.002523
-7.15	0.00	-0.000896	-0.001350	-0.001545	-0.001898
-7.50	0.00	-0.000912	-0.001270	-0.001454	-0.001827
-7.85	0.00	-0.001764	-0.000783	-0.001033	-0.001559
6.00	1.50	-0.000455	-0.001135	-0.001794	-0.002228
6.00	1.50	-0.000367	-0.003385	-0.004800	-0.007957
4.50	1.50	-0.000379	-0.001656	-0.003813	-0.007039
4.50	1.50	-0.000075	-0.001041	-0.002980	-0.006427
2.00	1.50	-0.000031	0.001048	0.003940	0.008264
0.50	1.50	-0.0000519	0.000462	0.003398	0.008112
-2.00	1.50	-0.000408	-0.001152	-0.000990	-0.001409
-3.50	1.50	-0.000799	-0.002138	-0.003558	-0.006555
-4.50	1.50	-0.002080	-0.004095	-0.007825	-0.010821
-5.50	1.50	-0.002080	-0.004095	-0.007825	-0.010821
-7.50	1.50	-0.001233	-0.001249	-0.001445	-0.001841
6.00	3.00	-0.003397	-0.001194	-0.001789	-0.002661
4.50	3.00	-0.00335	-0.001389	-0.003541	-0.003953
3.50	3.00	-0.000311	0.001048	0.003272	0.006014
2.00	3.00	-0.000435	0.000412	0.000823	0.008264
0.50	3.00	-0.000435	0.000412	0.000823	0.008264
-2.00	3.00	-0.000557	-0.000096	-0.002471	-0.005793
-3.50	3.00	-0.000503	-0.001203	-0.001164	-0.001757
-4.50	3.00	-0.001233	-0.001697	-0.003240	-0.005603
-6.00	3.00	-0.000572	-0.001904	-0.001841	-0.001841
-7.50	3.00	-0.000572	-0.001904	-0.002623	-0.003612

Force and Moment Summary

Balance h/D <sub>0</sub> =	0.85	5.88	4.70	3.52	2.32
Pressure A1/T =	-0.016	-0.030	-0.043	-0.065	-0.101
Balance A1/T =	-0.021	-0.036	-0.046	-0.064	-0.086
Pressure Δh/TD <sub>0</sub> =	0.008	0.012	0.012	0.005	0.041
Balance Δh/TD <sub>0</sub> =	0.014	0.013	0.027	0.027	0.035



Point	1	2	3	4	5
Total Thrust =	8.81	5.89	4.71	3.51	2.33
NPR Front =	52.74	52.50	52.41	52.37	52.39
NPR Aft =	2.02	2.02	2.02	2.02	2.02
X-loc	2.01	2.01	2.01	2.01	2.01
Y-loc	ACP	ACP	ACP	ACP	ACP
7.85	0.00	-0.001100	-0.000609	-0.001048	-0.001806
7.50	0.00	-0.001334	-0.000571	-0.001839	-0.002653
7.15	0.00	-0.001505	-0.000613	-0.001692	-0.002842
6.80	0.00	-0.001702	-0.000815	-0.002815	-0.003495
5.20	0.00	-0.001673	-0.000819	-0.001145	-0.004974
4.85	0.00	-0.000460	-0.00164	-0.001776	-0.004321
4.50	0.00	-0.000565	-0.000626	-0.002904	-0.006670
4.15	0.00	-0.000418	-0.000731	-0.001507	-0.007050
3.50	0.00	-0.000310	-0.000687	-0.000050	-0.013270
2.75	0.00	-0.000379	-0.000589	-0.001947	-0.000758
2.00	0.00	-0.000512	-0.001197	-0.004984	-0.004532
1.25	0.00	-0.000483	-0.000208	-0.005375	-0.007704
0.50	0.00	-0.000645	-0.000979	-0.003988	-0.008462
-0.50	0.00	-0.000581	-0.001865	-0.000496	-0.002072
-1.25	0.00	-0.000527	-0.001414	-0.001848	-0.002632
-2.00	0.00	-0.000611	-0.001815	-0.002894	-0.005924
-2.75	0.00	-0.000615	-0.001865	-0.003349	-0.007779
-3.50	0.00	-0.000768	-0.001968	-0.004167	-0.008468
-4.15	0.00	-0.000758	-0.001785	-0.003870	-0.008056
-4.50	0.00	-0.000866	-0.002122	-0.004241	-0.007511
-4.85	0.00	-0.001221	-0.002042	-0.004395	-0.006639
-5.20	0.00	-0.001881	-0.003571	-0.004033	-0.005473
-6.80	0.00	-0.001581	-0.003798	-0.003696	-0.004502
-7.15	0.00	-0.001034	-0.002439	-0.002651	-0.003083
-7.50	0.00	-0.000822	-0.002295	-0.002131	-0.002603
-7.85	0.00	-0.000788	-0.002334	-0.002458	-0.002781
6.00	0.80	-0.001514	-0.003786	-0.017675	-0.021412
7.50	1.50	-0.000908	-0.000525	-0.001603	-0.003209
6.00	1.50	-0.000669	-0.002991	-0.006721	-0.008663
4.50	1.50	-0.000544	-0.000681	-0.003923	-0.008591
3.50	1.50	-0.000374	-0.000415	-0.000951	-0.005736
2.00	1.50	-0.000374	-0.000415	-0.000951	-0.005736
0.50	1.50	-0.000606	-0.000564	-0.002155	-0.008259
-2.00	1.50	-0.000596	-0.001424	-0.000590	-0.002776
-3.50	1.50	-0.000684	-0.002003	-0.002606	-0.006073
-4.50	1.50	-0.000729	-0.002206	-0.004271	-0.008537
-6.00	1.50	-0.002486	-0.003007	-0.005306	-0.005984
-7.50	1.50	-0.000905	-0.002963	-0.002215	-0.002493
7.50	3.00	-0.006655	-0.001038	-0.002328	-0.002843
6.00	3.00	-0.007214	-0.007389	-0.006932	-0.007130
4.50	3.00	-0.006677	-0.000718	-0.002306	-0.006140
3.50	3.00	-0.006006	-0.000564	-0.002155	-0.008259
2.00	3.00	-0.006679	-0.000178	-0.002919	-0.004095
0.50	3.00	-0.006679	-0.000178	-0.002919	-0.004095
-0.50	3.00	-0.006335	-0.001983	-0.001051	-0.001964
-2.00	3.00	-0.006889	-0.001934	-0.003344	-0.004889
-3.50	3.00	-0.006889	-0.002215	-0.004236	-0.006728
-4.50	3.00	-0.000905	-0.002963	-0.002215	-0.002493
-6.00	3.00	-0.000719	-0.002082	-0.002923	-0.004303
-7.50	3.00	-0.000719	-0.002082	-0.002923	-0.004303

Force and Moment Summary

h/De =	8.81	5.89	4.71	3.51	2.33
Balance AL/T =	-0.018	-0.034	-0.047	-0.077	-0.129
Pressure AL/T =	-0.030	-0.048	-0.059	-0.083	-0.126
Balance AM/TDe =	-0.052	0.010	0.008	0.011	0.005
Pressure AM/TDe =	-0.015	0.022	0.020	0.020	0.023

Moment reference point

Balance center

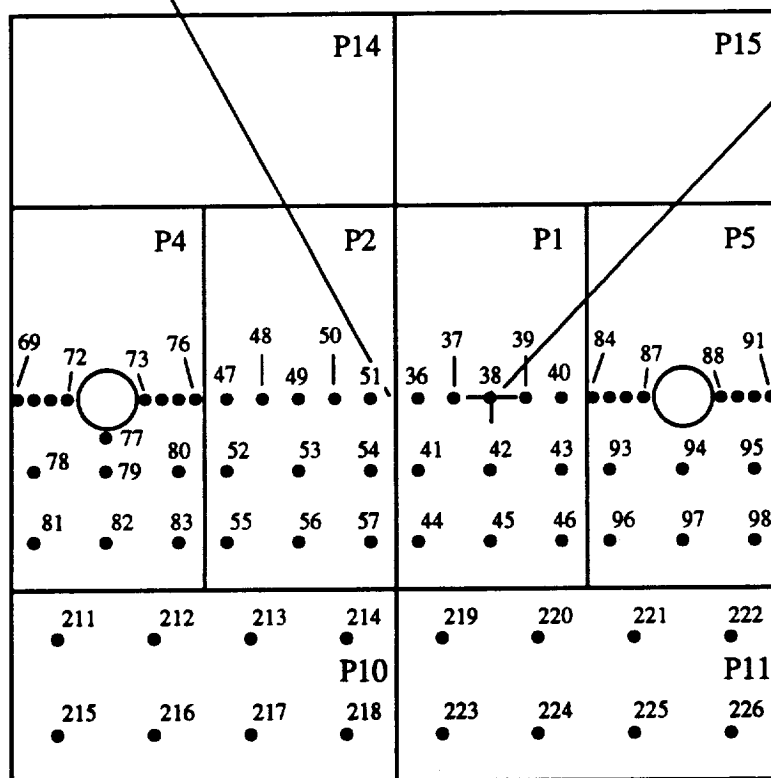

Figure 59. Configuration 2C\_12\_0\_16/16;  $D_e = 1.697$  in.,  $A_{jet} = 2.26$  in.<sup>2</sup>.

Pressure Orifice Locations and Weighting Factors

Conf. # 2C\_12\_0\_16/16

Distance from balance center to moment reference point,  $X_o = 2$

Orif. #	Mom. arm	Sta. y	$\Delta$ .Area	Sta. x
69	7.85	0	0.634	7.85
70	7.5	0	0.683	7.5
71	7.15	0	0.683	7.15
72	6.8	0	0.619	6.8
73	5.2	0	0.619	5.2
74	4.85	0	0.683	4.85
75	4.5	0	0.683	4.5
76	4.15	0	0.634	4.15
77	6	0.8	1.238	6
78	7.5	1.5	3.19	7.5
79	6	1.5	3.825	6
80	4.5	1.5	3.19	4.5
81	7.5	3	4.375	7.5
82	6	3	5.25	6
83	4.5	3	4.375	4.5
47	3.5	0	1.313	3.5
48	2.75	0	1.125	2.75
49	2	0	1.125	2
50	1.25	0	1.125	1.25
51	0.5	0	1.313	0.5
52	3.5	1.5	3.75	3.5
53	2	1.5	4.5	2
54	0.5	1.5	3.75	0.5
55	3.5	3	4.375	3.5
56	2	3	5.25	2
57	0.5	3	4.375	0.5
36	-0.5	0	1.313	-0.5
37	-1.25	0	1.125	-1.25
38	-2	0	1.125	-2
39	-2.75	0	1.125	-2.75
40	-3.5	0	1.313	-3.5
41	-0.5	1.5	3.75	-0.5
42	-2	1.5	4.5	-2
43	-3.5	1.5	3.75	-3.5
44	-0.5	3	4.375	-0.5
45	-2	3	5.25	-2
46	-3.5	3	4.375	-3.5
84	-4.15	0	0.634	-4.15
85	-4.5	0	0.683	-4.5
86	-4.85	0	0.683	-4.85
87	-5.2	0	0.619	-5.2
88	-6.8	0	0.619	-6.8
89	-7.15	0	0.683	-7.15
90	-7.5	0	0.683	-7.5
91	-7.85	0	0.634	-7.85
93	-4.5	1.5	3.19	-4.5

Conf. # 2C\_12\_0\_16/16, continued

Orif. #	Mom. arm	Sta. y	Δ.Area	Sta. x
94	-6	1.5	5.062	-6
95	-7.5	1.5	3.19	-7.5
96	-4.5	3	4.375	-4.5
97	-6	3	5.25	-6
98	-7.5	3	4.375	-7.5
211	7	5	8	7
212	5	5	8	5
213	3	5	8	3
214	1	5	8	1
215	7	7	8	7
216	5	7	8	5
217	3	7	8	3
218	1	7	8	1
219	-1	5	8	-1
220	-3	5	8	-3
221	-5	5	8	-5
222	-7	5	8	-7
223	-1	7	8	-1
224	-3	7	8	-3
225	-5	7	8	-5
226	-7	7	8	-7

Configuration: 2C-12-0-16/16 Jet-Induced Pressure Increments Run 214

Point	1	2	3	4	5
h/De =	8.85	5.87	4.70	3.51	2.30
Total Thrust =	51.51	51.00	50.84	50.73	50.65
NPR Front =	2.01	2.00	2.00	1.99	1.99
NPR Aft =	1.98	1.96	1.96	1.96	1.95
X-loc	ACP	ACP	ACP	ACP	ACP
Y-loc	ACP	ACP	ACP	ACP	ACP
7.85	0.000715	-0.000951	-0.002490	-0.004713	-0.006276
7.50	-0.000569	-0.002080	-0.002716	-0.004470	-0.005897
7.15	-0.001426	-0.003222	-0.003262	-0.004735	-0.006288
6.80	-0.001674	-0.003828	-0.004460	-0.005935	-0.007094
6.50	-0.002068	-0.004261	-0.002260	-0.004170	-0.008749
4.85	-0.002201	-0.003200	-0.004152	-0.007831	-0.011996
4.50	-0.001948	-0.003909	-0.005549	-0.008918	-0.014971
4.15	-0.001862	-0.003789	-0.006117	-0.009846	-0.017508
3.50	-0.001224	-0.003809	-0.004694	-0.009275	-0.018240
2.75	-0.001588	-0.002887	-0.004086	-0.007868	-0.017668
2.00	-0.000968	-0.002020	-0.004040	-0.007264	-0.013954
1.25	-0.000837	0.001039	0.002237	0.001003	-0.002122
0.50	-0.000237	0.002418	0.005056	0.006500	0.011246
-0.50	0.001366	0.004338	0.006420	0.008676	0.013095
-1.25	0.001486	0.003885	0.004597	0.003352	0.001512
-2.00	0.000202	0.001212	0.000924	-0.000522	-0.011032
-2.75	0.000282	0.001257	-0.002824	-0.005553	-0.015364
-3.50	0.000842	-0.001319	-0.004045	-0.008297	-0.017767
-4.15	0.000146	-0.002434	-0.005214	-0.009774	-0.017624
-4.85	-0.000751	-0.002536	-0.003943	-0.008778	-0.015480
-5.20	-0.001577	-0.001273	-0.002135	-0.003742	-0.009200
-6.80	-0.001577	-0.003584	-0.005399	-0.007012	-0.007557
-7.15	-0.000343	-0.001573	-0.004035	-0.005196	-0.005894
-7.50	-0.000348	-0.001507	-0.003003	-0.004413	-0.005994
6.00	-0.005048	-0.010738	-0.011869	-0.003624	-0.006363
7.50	-0.001104	-0.001877	-0.003544	-0.004231	-0.005954
4.50	-0.001978	-0.004463	-0.006781	-0.008657	-0.008815
3.50	-0.001738	-0.004182	-0.005931	-0.010505	-0.014087
2.00	-0.001649	-0.003625	-0.005117	-0.009302	-0.017525
0.50	-0.000544	-0.002556	-0.005117	-0.009302	-0.017525
-0.50	0.000967	0.004364	0.005490	0.008149	0.013935
-1.50	0.001220	0.003487	0.001430	-0.002646	-0.011943
-2.00	0.000549	-0.002439	-0.004801	-0.009944	-0.018017
-3.50	-0.005978	-0.012885	-0.014967	-0.014884	-0.012032
-4.50	-0.005978	-0.012885	-0.014967	-0.014884	-0.012032
-6.00	-0.003333	-0.001752	-0.002768	-0.003987	-0.006003
-7.50	-0.001045	-0.001536	-0.002073	-0.003718	-0.005301
6.00	-0.003558	-0.004441	-0.005184	-0.005344	-0.005862
4.50	-0.000731	-0.003559	-0.005913	-0.009551	-0.014301
3.50	-0.000544	-0.002556	-0.004101	-0.007806	-0.010790
2.00	-0.000731	-0.000489	-0.000965	-0.003993	-0.013506
0.50	0.001043	0.003595	0.003897	0.006040	0.009406
-2.00	0.000862	0.000687	-0.000868	-0.002078	-0.011309
-3.50	-0.000081	-0.000769	-0.005149	-0.008471	-0.016445
-4.50	-0.000333	-0.001752	-0.002768	-0.003987	-0.006003
-6.00	-0.000897	-0.003768	-0.005843	-0.007745	-0.008536
-7.50	-0.001195	-0.001981	-0.002716	-0.003748	-0.004856
5.00	-0.001588	-0.003252	-0.005050	-0.007935	-0.009826
3.00	-0.001028	-0.002556	-0.003632	-0.006883	-0.014033
1.00	-0.000510	-0.000532	0.000325	0.002583	0.001124
-1.00	0.000206	0.002725	0.001813	0.002731	0.000466
-3.00	0.000381	-0.000221	-0.003301	-0.006870	-0.013265
-5.00	-0.000415	-0.003023	-0.005076	-0.006896	-0.009486
-7.00	-0.000685	-0.002322	-0.003254	-0.003448	-0.004120
7.00	-0.001070	-0.001596	-0.002070	-0.002453	-0.003367

Force and Moment Summary

Balance	h/De =	8.85	5.87	4.70	3.51	2.30
Pressure AL/T =	-0.034	-0.077	-0.132	-0.222	-0.388	
Pressure AH/TDe =	-0.046	-0.085	-0.149	-0.220	-0.372	
Pressure AM/TDe =	-0.039	0.004	0.014	0.046	0.070	
Pressure AN/TDe =	-0.046	0.018	0.052	0.049	0.031	



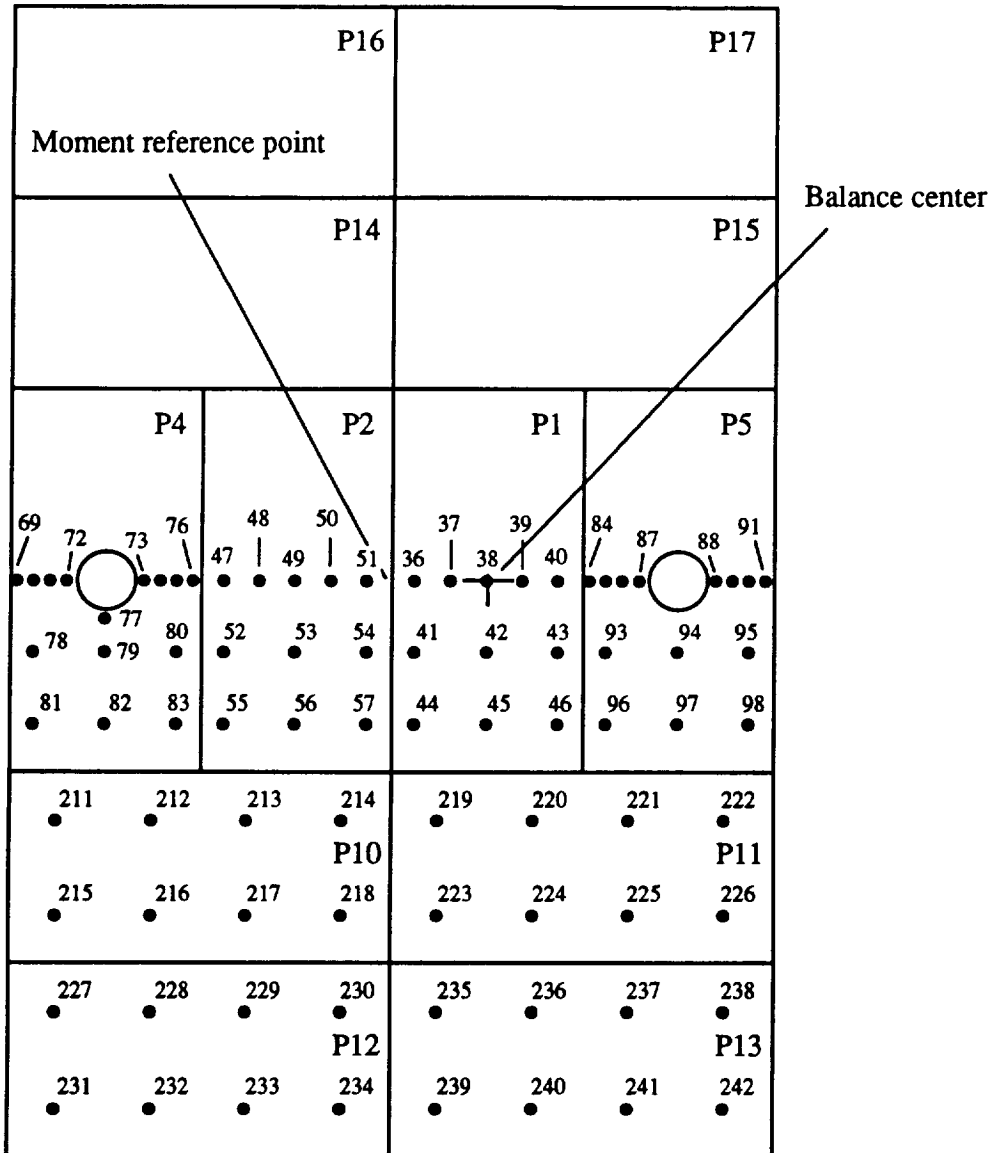

Figure 60. Configuration 2C\_12\_0\_16/24;  $D_e = 1.697$  in.,  $A_{jet} = 2.26$  in.<sup>2</sup>.

Pressure Orifice Locations and Weighting Factors

Conf. # 2C\_12\_0\_16/24

Distance from balance center to moment reference point,  $X_0 = 2$

Orif. #	Mom. arm	Sta. y	$\Delta$ .Area	Sta. x
69	7.85	0	0.634	7.85
70	7.5	0	0.683	7.5
71	7.15	0	0.683	7.15
72	6.8	0	0.619	6.8
73	5.2	0	0.619	5.2
74	4.85	0	0.683	4.85
75	4.5	0	0.683	4.5
76	4.15	0	0.634	4.15
77	6	0.8	1.238	6
78	7.5	1.5	3.19	7.5
79	6	1.5	3.825	6
80	4.5	1.5	3.19	4.5
81	7.5	3	4.375	7.5
82	6	3	5.25	6
83	4.5	3	4.375	4.5
47	3.5	0	1.313	3.5
48	2.75	0	1.125	2.75
49	2	0	1.125	2
50	1.25	0	1.125	1.25
51	0.5	0	1.313	0.5
52	3.5	1.5	3.75	3.5
53	2	1.5	4.5	2
54	0.5	1.5	3.75	0.5
55	3.5	3	4.375	3.5
56	2	3	5.25	2
57	0.5	3	4.375	0.5
36	-0.5	0	1.313	-0.5
37	-1.25	0	1.125	-1.25
38	-2	0	1.125	-2
39	-2.75	0	1.125	-2.75
40	-3.5	0	1.313	-3.5
41	-0.5	1.5	3.75	-0.5
42	-2	1.5	4.5	-2
43	-3.5	1.5	3.75	-3.5
44	-0.5	3	4.375	-0.5
45	-2	3	5.25	-2
46	-3.5	3	4.375	-3.5
84	-4.15	0	0.634	-4.15
85	-4.5	0	0.683	-4.5
86	-4.85	0	0.683	-4.85
87	-5.2	0	0.619	-5.2
88	-6.8	0	0.619	-6.8
89	-7.15	0	0.683	-7.15
90	-7.5	0	0.683	-7.5
91	-7.85	0	0.634	-7.85
93	-4.5	1.5	3.19	-4.5



Conf. # 2C\_12\_0\_16/24, continued

Orif. #	Mom. arm	Sta. y	Δ.Area	Sta. x
94	-6	1.5	5.062	-6
95	-7.5	1.5	3.19	-7.5
96	-4.5	3	4.375	-4.5
97	-6	3	5.25	-6
98	-7.5	3	4.375	-7.5
211	7	5	8	7
212	5	5	8	5
213	3	5	8	3
214	1	5	8	1
215	7	7	8	7
216	5	7	8	5
217	3	7	8	3
218	1	7	8	1
219	-1	5	8	-1
220	-3	5	8	-3
221	-5	5	8	-5
222	-7	5	8	-7
223	-1	7	8	-1
224	-3	7	8	-3
225	-5	7	8	-5
226	-7	7	8	-7
227	7	9	8	7
228	5	9	8	5
229	3	9	8	3
230	1	9	8	1
231	7	11	8	7
232	5	11	8	5
233	3	11	8	3
234	1	11	8	1
235	-1	9	8	-1
236	-3	9	8	-3
237	-5	9	8	-5
238	-7	9	8	-7
239	-1	11	8	-1
240	-3	11	8	-3
241	-5	11	8	-5
242	-7	11	8	-7

Configuration: 2C-12-0-16/24  
 Jet-Induced Pressure Increments  
 Run 216

Point	2	3	4	5	6	7	8
h/D <sub>e</sub> =	17.70	11.79	8.85	5.90	4.73	3.51	2.33
Total Thrust =	51.34	50.95	50.80	50.77	50.88	50.88	50.83
NPR Front =	2.03	2.02	2.02	2.02	2.03	2.03	2.03
NPR Aft =	1.97	1.96	1.95	1.95	1.95	1.95	1.95
X-loc	ACP	ACP	ACP	ACP	ACP	ACP	ACP
Y-loc	ACP	ACP	ACP	ACP	ACP	ACP	ACP
7.85	0.00	0.000107	-0.000541	-0.001407	-0.001860	-0.004651	-0.007598
7.50	0.00	-0.000172	0.000641	-0.001998	-0.002627	-0.004812	-0.007520
7.15	0.00	-0.000418	-0.010222	-0.000969	-0.002233	-0.005688	-0.007841
6.80	0.00	-0.000937	-0.014588	-0.003141	-0.004522	-0.007283	-0.008522
6.45	0.00	-0.001322	-0.023381	-0.005199	-0.002068	-0.004964	-0.005983
6.10	0.00	-0.000893	-0.014482	-0.002293	-0.004894	-0.008456	-0.014326
5.75	0.00	-0.000511	-0.014482	-0.003732	-0.005371	-0.003755	-0.017191
5.40	0.00	-0.000389	-0.000393	-0.002058	-0.002746	-0.003529	-0.019266
5.05	0.00	-0.000238	-0.000393	-0.002058	-0.002746	-0.003529	-0.019266
4.70	0.00	-0.000121	-0.011065	-0.000450	-0.003327	-0.007650	-0.020887
4.35	0.00	-0.000061	-0.000183	-0.001199	-0.000434	-0.002557	-0.015591
4.00	0.00	-0.000000	-0.000754	-0.000685	0.003437	0.003445	0.004746
3.65	0.00	-0.000005	-0.000489	-0.000383	0.004015	0.007489	0.008999
3.30	0.00	-0.000020	-0.000031	0.001129	0.005330	0.006594	0.013363
2.95	0.00	-0.000025	-0.000041	0.001554	0.003330	0.004576	0.007401
2.60	0.00	-0.000030	-0.000301	0.000884	0.003089	0.002168	-0.014301
2.25	0.00	-0.000000	-0.000199	0.000756	0.000118	-0.000817	-0.002645
1.90	0.00	-0.000147	-0.000250	0.000174	-0.001202	-0.004511	-0.009386
1.55	0.00	-0.000167	-0.000081	0.000204	-0.002700	-0.004230	-0.010760
1.20	0.00	-0.000440	-0.000163	0.000164	-0.002900	-0.004951	-0.015935
0.85	0.00	-0.000617	-0.000560	-0.000470	-0.002000	-0.003756	-0.001716
0.50	0.00	-0.001380	-0.011142	-0.01073	-0.001421	-0.001639	-0.007195
0.15	0.00	-0.001173	-0.011289	-0.02382	-0.003969	-0.005001	-0.006619
7.85	0.00	-0.000602	-0.000245	-0.000491	-0.001156	-0.003582	-0.004761
7.50	0.00	-0.000470	-0.000703	-0.000414	-0.002020	-0.002740	-0.006610
7.15	0.00	-0.000308	-0.000158	-0.000317	-0.001212	-0.002148	-0.003751
6.80	0.00	-0.001551	-0.002598	-0.006247	-0.011722	-0.018688	-0.025092
6.45	1.50	-0.000219	-0.000749	-0.001116	-0.002389	-0.004856	-0.006783
6.10	1.50	-0.000554	-0.001450	-0.002175	-0.005908	-0.007244	-0.009979
5.75	1.50	-0.000400	-0.000970	-0.001537	-0.004344	-0.006646	-0.013239
5.40	1.50	-0.000162	-0.000820	-0.001503	-0.001887	-0.005042	-0.009430
5.05	1.50	-0.000056	-0.000209	-0.000480	0.005712	0.004823	0.006880
4.70	1.50	-0.000015	-0.000020	0.000332	0.005667	0.005981	0.007308
4.35	1.50	-0.000015	-0.000020	0.001334	0.001565	0.001802	0.003802
4.00	1.50	-0.000207	-0.000100	0.000383	-0.002440	-0.004623	-0.009261
3.65	1.50	-0.002534	-0.002894	-0.004339	-0.12267	-0.19228	-0.15103
3.30	1.50	-0.002534	-0.002894	-0.004339	-0.12267	-0.19228	-0.15103
2.95	1.50	-0.000238	-0.000362	-0.000353	-0.001841	-0.002705	-0.003869
2.60	1.50	-0.000301	-0.000822	-0.000890	-0.002081	-0.002319	-0.004192
2.25	3.00	0.012275	0.011129	0.008878	0.006038	0.004388	0.003728
1.90	3.00	-0.000232	-0.001035	-0.001624	-0.003936	-0.005887	-0.009790
1.55	3.00	-0.000005	-0.000209	-0.000480	0.005712	0.004823	0.006680
1.20	3.00	-0.00101	-0.000387	-0.000087	0.000895	0.001071	0.003164
0.85	3.00	-0.000005	-0.000438	0.001451	0.003662	0.004026	0.005298
0.50	3.00	-0.000081	-0.000117	0.000680	-0.01259	-0.000745	-0.004022
7.85	3.00	-0.000071	0.000148	-0.000680	-0.023394	-0.004471	-0.009617
7.50	3.00	-0.000425	-0.000566	-0.000772	-0.004096	-0.006272	-0.007783
7.15	3.00	-0.000425	-0.000566	-0.000772	-0.004096	-0.006272	-0.007783
6.80	3.00	-0.000189	-0.000628	-0.001150	-0.003306	-0.005414	-0.004040
6.45	5.00	-0.000189	-0.000628	-0.001150	-0.003306	-0.005414	-0.004040
6.10	5.00	-0.000172	-0.000528	-0.001146	-0.001889	-0.003928	-0.007794
5.75	5.00	-0.000043	-0.000407	-0.000404	0.003258	0.001695	0.000871
5.40	5.00	-0.000017	-0.000238	-0.000890	0.002024	0.002172	0.002393
5.05	5.00	-0.000069	-0.000173	-0.000373	-0.001490	-0.003429	-0.006451
4.70	5.00	-0.000571	-0.000433	-0.000634	-0.003376	-0.005345	-0.008215
4.35	5.00	-0.000134	-0.000560	-0.000560	-0.002259	-0.002766	-0.003676
4.00	5.00	-0.000180	-0.000567	-0.000929	-0.002324	-0.002787	-0.003372
3.65	7.00	-0.000137	-0.000701	-0.001011	-0.002915	-0.004422	-0.006394
3.30	7.00	-0.000150	-0.000797	-0.001321	-0.000943	-0.003390	-0.005592
2.95	7.00	-0.000112	-0.001126	-0.000152	0.001173	0.001284	0.000230
2.60	7.00	-0.000129	-0.001139	-0.000052	0.000443	0.000464	0.001708
2.25	7.00	-0.000094	-0.000221	0.000104	-0.001455	-0.002735	-0.005415
1.90	7.00	-0.000185	-0.000078	-0.000230	-0.002933	-0.004673	-0.006359
1.55	7.00	-0.000455	-0.000610	-0.000412	-0.001430	-0.002371	-0.002523
1.20	7.00	-0.000455	-0.000610	-0.000412	-0.001430	-0.002371	-0.002523

Force and Moment Summary  
 h/D<sub>e</sub> = 17.70  
 Balance AL/T = 8.85  
 Pressure AL/T = -0.043  
 Pressure AM/T<sub>e</sub> = 0.046  
 Pressure AM/T<sub>De</sub> = 0.072  
 5.90  
 -0.108  
 -0.098  
 0.102  
 0.077  
 4.73  
 -0.179  
 -0.192  
 0.117  
 0.107  
 3.51  
 -0.296  
 -0.436  
 0.144  
 0.064  
 2.33  
 -0.510  
 -0.496  
 0.161  
 0.010

Configuration: 2C-12-0-16/24 Run 217

Point	1	2	3	4	5	6	7
h/De =	17.68	11.81	8.85	5.90	4.72	3.54	2.35
Total Throat =	137.43	137.20	137.69	137.58	137.58	137.72	137.64
NPR Front =	4.00	4.00	4.01	4.01	4.01	4.01	4.01
NPR Aft =	4.00	4.00	4.01	4.00	4.00	4.01	4.01
X-loc	ACP	ACP	ACP	ACP	ACP	ACP	ACP
Y-loc	ACP	ACP	ACP	ACP	ACP	ACP	ACP
7.85	-0.000234	-0.000434	-0.000492	-0.001303	-0.002263	-0.004173	-0.005651
7.50	-0.000387	-0.000421	-0.000687	-0.001908	-0.003959	-0.004771	-0.005401
7.15	-0.000547	-0.000730	-0.000996	-0.001807	-0.003990	-0.004771	-0.005401
6.80	-0.001255	-0.001381	-0.001692	-0.002849	-0.005016	-0.005684	-0.005683
6.50	-0.001462	-0.001018	-0.000996	-0.000699	-0.000896	-0.001499	-0.002428
4.85	-0.000734	-0.000672	-0.000987	-0.000901	-0.002406	-0.005944	-0.010854
4.50	-0.000474	-0.000563	-0.000626	-0.002268	-0.004276	-0.008222	-0.011557
4.15	-0.000392	-0.000576	-0.000733	-0.002520	-0.004622	-0.009501	-0.011792
3.50	-0.000117	-0.000314	-0.000377	-0.001206	-0.003644	-0.007801	-0.012821
2.75	-0.000051	-0.000155	-0.000273	-0.000330	-0.001401	-0.005374	-0.011697
2.00	-0.000051	-0.000384	-0.000556	-0.001776	-0.001151	-0.000826	-0.008703
1.25	-0.000028	-0.000259	-0.000792	-0.002952	-0.004383	-0.003785	-0.003035
0.50	-0.000010	-0.000174	-0.000024	-0.004661	-0.006852	-0.007822	-0.016671
-0.50	-0.000004	-0.000223	-0.000752	-0.003681	-0.004902	-0.006649	-0.013663
-1.25	-0.000083	-0.000078	-0.000219	-0.002123	-0.003112	-0.003039	-0.002022
-2.00	-0.000159	-0.000123	-0.000897	-0.000670	-0.000110	-0.002815	-0.011040
-2.75	-0.000110	-0.000288	-0.000168	-0.001310	-0.002363	-0.005925	-0.016598
-3.50	-0.000176	-0.000350	-0.000651	-0.002565	-0.003516	-0.008005	-0.018031
-4.15	-0.000253	-0.000799	-0.001139	-0.002333	-0.004650	-0.008116	-0.016072
-4.50	-0.000272	-0.000784	-0.001124	-0.002244	-0.004173	-0.007200	-0.013705
-4.85	-0.000493	-0.000833	-0.001462	-0.002163	-0.002163	-0.004956	-0.008197
-5.20	-0.000707	-0.001463	-0.000952	-0.000566	-0.000553	-0.001292	-0.004276
-6.80	-0.000937	-0.001605	-0.001729	-0.003514	-0.004390	-0.005975	-0.005702
-7.15	-0.000198	-0.000740	-0.000986	-0.001604	-0.003250	-0.004861	-0.005054
-7.50	-0.000176	-0.000604	-0.000702	-0.001404	-0.002535	-0.003754	-0.004992
-7.85	-0.000259	-0.000723	-0.000503	-0.001212	-0.001968	-0.003583	-0.005498
6.00	-0.001761	-0.002178	-0.005015	-0.013623	-0.016420	-0.017244	-0.009723
7.50	-0.000364	-0.000584	-0.000699	-0.002217	-0.002882	-0.004475	-0.005404
6.00	-0.000612	-0.000662	-0.002134	-0.005142	-0.007196	-0.009981	-0.008645
4.50	-0.000263	-0.000666	-0.001246	-0.003322	-0.005835	-0.009794	-0.017342
3.50	-0.000176	-0.000630	-0.000322	-0.001432	-0.003802	-0.008172	-0.019013
2.50	-0.000177	-0.000708	-0.000624	-0.004441	-0.006070	-0.007822	-0.016372
-2.00	-0.000083	-0.000301	-0.000422	-0.002938	-0.005517	-0.005565	-0.012825
-3.50	-0.000197	-0.000441	-0.000783	-0.002070	-0.004081	-0.008882	-0.018639
-4.50	-0.000179	-0.001601	-0.004400	-0.011017	-0.013873	-0.018050	-0.009810
-5.00	-0.000094	-0.000465	-0.000892	-0.001783	-0.002478	-0.003682	-0.005302
7.50	-0.000342	-0.000470	-0.000873	-0.001829	-0.002935	-0.003799	-0.005302
6.00	-0.001684	-0.001378	-0.001833	-0.001514	-0.001826	-0.002660	-0.002570
4.50	-0.000162	-0.000756	-0.000501	-0.003057	-0.005687	-0.010300	-0.016316
3.50	-0.000121	-0.000178	-0.000624	-0.004441	-0.006070	-0.007822	-0.016372
3.00	-0.000121	-0.00178	-0.000311	-0.000997	-0.000889	-0.002523	-0.010166
2.50	-0.000555	-0.000051	-0.000194	-0.002971	-0.004919	-0.005968	-0.009371
-2.00	-0.000074	-0.000218	-0.000879	-0.000529	-0.000815	-0.003968	-0.017926
-3.50	-0.000094	-0.000456	-0.000892	-0.001783	-0.002478	-0.003682	-0.005025
-4.50	-0.000406	-0.000395	-0.001539	-0.003464	-0.005410	-0.007052	-0.006359
-7.50	-0.000613	-0.000240	-0.000641	-0.002280	-0.003256	-0.004268	-0.005506
5.00	-0.000303	-0.000727	-0.000878	-0.003295	-0.004990	-0.007980	-0.012270
3.00	-0.000181	-0.000333	-0.000309	-0.000891	-0.003416	-0.007402	-0.016365
1.00	-0.000138	-0.000222	-0.000338	-0.001198	-0.001387	-0.002079	-0.002074
-1.00	-0.000138	-0.000222	-0.000338	-0.001198	-0.001387	-0.002079	-0.002074
-3.00	-0.000173	-0.000545	-0.001312	-0.003056	-0.004911	-0.007957	-0.015287
-5.00	-0.000425	-0.000585	-0.000961	-0.002339	-0.002793	-0.004239	-0.005112
7.00	-0.000512	-0.000317	-0.000642	-0.001876	-0.002636	-0.003187	-0.003439
5.00	-0.000178	-0.000344	-0.000404	-0.002703	-0.004806	-0.006384	-0.009148
3.00	-0.000157	-0.000153	-0.000280	-0.001131	-0.001278	-0.002711	-0.012043
1.00	-0.000140	-0.000074	-0.000561	-0.001118	-0.001866	-0.000082	-0.001490
-1.00	-0.000210	-0.000299	-0.000586	-0.001435	-0.001552	-0.000356	-0.000366
-3.00	-0.000149	-0.000439	-0.001205	-0.003120	-0.005536	-0.009116	-0.011176
-5.00	-0.000343	-0.000526	-0.000862	-0.001626	-0.001845	-0.003136	-0.003090

Force and Moment Summary  
 h/De = 17.68 11.81 8.85 5.90 4.72 3.54 2.35  
 Balance AL/T = -0.015 -0.026 -0.038 -0.102 -0.167 -0.283 -0.489  
 Pressure AL/T = -0.025 -0.036 -0.052 -0.180 -0.307 -0.507 -0.849  
 Balance AM/TDe = 0.029 0.079 0.079 0.079 0.087 0.117 0.083  
 Pressure AM/TDe = -0.007 0.004 0.046 0.053 0.047 0.071 -0.002

Configuration: 2C-12-0-16/24 Jet-Induced Pressure Increments Run 218

Point	1	2	3	4	5	6
h/De =	17.72	11.81	8.87	5.91	4.73	3.53
Total Thrust =	225.61	225.65	225.59	225.54	225.32	225.40
NPR Front =	5.97	5.97	5.97	5.97	5.97	5.97
NPR Aft =	6.04	6.04	6.04	6.04	6.03	6.03
X-loc	ACP	ACP	ACP	ACP	ACP	ACP
Y-loc	ACP	ACP	ACP	ACP	ACP	ACP

Point	1	2	3	4	5	6
h/De =	9.00	11.81	8.87	5.91	4.73	3.53
Total Thrust =	7.00	11.81	8.87	5.91	4.73	3.53
NPR Front =	5.00	11.81	8.87	5.91	4.73	3.53
NPR Aft =	3.00	11.81	8.87	5.91	4.73	3.53
X-loc	ACP	ACP	ACP	ACP	ACP	ACP
Y-loc	ACP	ACP	ACP	ACP	ACP	ACP

Point	1	2	3	4	5	6
h/De =	17.72	11.81	8.87	5.91	4.73	3.53
Total Thrust =	225.61	225.65	225.59	225.54	225.32	225.40
NPR Front =	5.97	5.97	5.97	5.97	5.97	5.97
NPR Aft =	6.04	6.04	6.04	6.04	6.03	6.03
X-loc	ACP	ACP	ACP	ACP	ACP	ACP
Y-loc	ACP	ACP	ACP	ACP	ACP	ACP

Force and Moment Summary

Balance	h/De =	17.72	11.81	8.87	5.91	4.73	3.53
Pressure	AL/T =	-0.013	-0.026	-0.037	-0.057	-0.073	-0.084
Balance	AL/T =	0.018	0.032	0.046	0.065	0.084	0.099
Pressure	ΔM/TDe =	0.028	0.060	0.088	0.125	0.168	0.215
Balance	ΔM/TDe =	-0.009	0.017	0.029	0.050	0.073	0.099

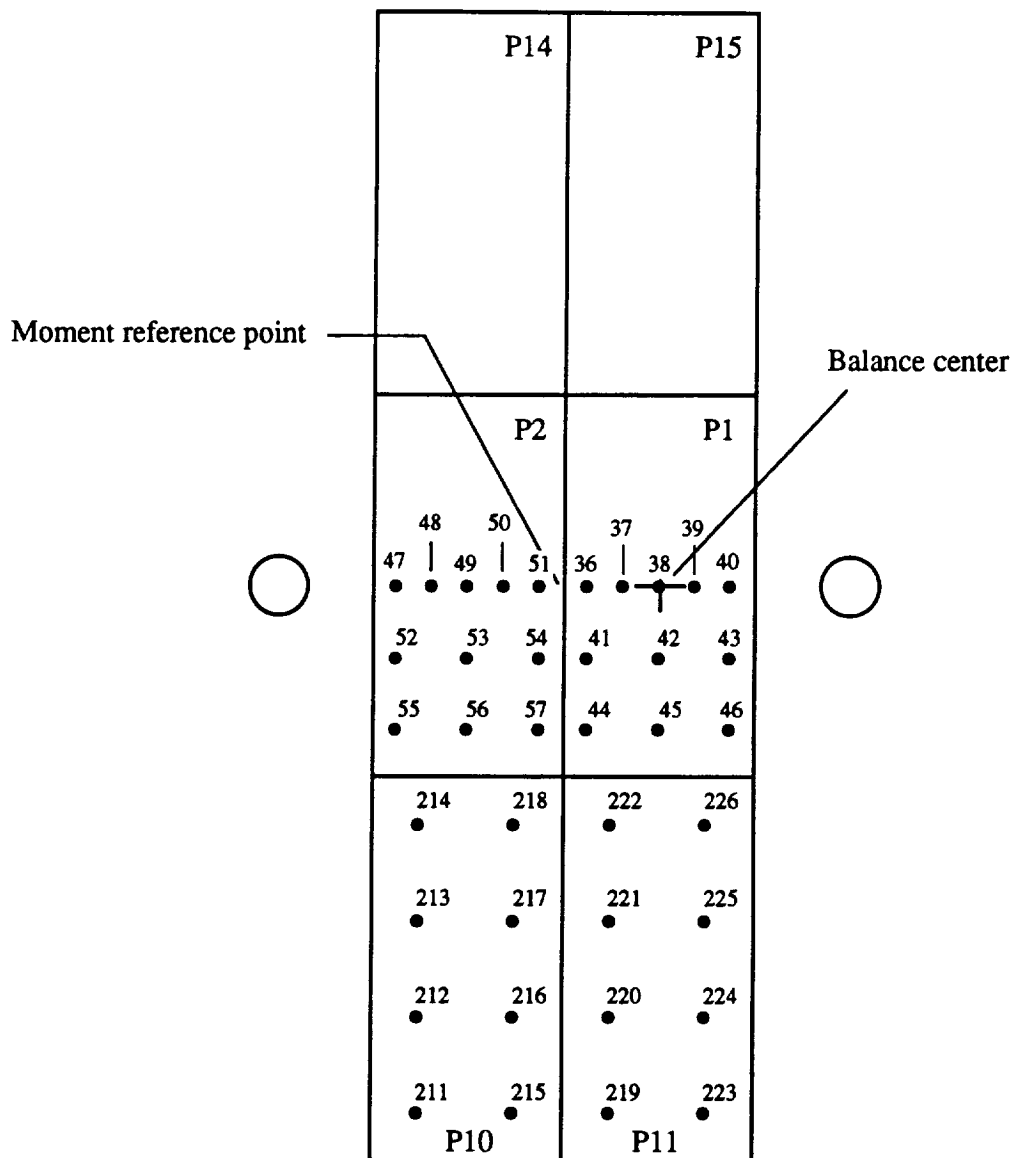

Figure 61. Configuration 2C\_12\_0\_8/24;  $D_e = 1.697$  in.,  $A_{jet} = 2.26$  in.<sup>2</sup>.

Pressure Orifice Locations and Weighting Factors

Conf. # 2C\_12\_0\_8/24

Distance from balance center to moment reference point,  $X_0 = 2$

Orif. #	Mom. arm	Sta. y	$\Delta$ .Area	Sta. x
47	3.5	0	1.313	3.5
48	2.75	0	1.125	2.75
49	2	0	1.125	2
50	1.25	0	1.125	1.25
51	0.5	0	1.313	0.5
52	3.5	1.5	3.75	3.5
53	2	1.5	4.5	2
54	0.5	1.5	3.75	0.5
55	3.5	3	4.375	3.5
56	2	3	5.25	2
57	0.5	3	4.375	0.5
36	-0.5	0	1.313	-0.5
37	-1.25	0	1.125	-1.25
38	-2	0	1.125	-2
39	-2.75	0	1.125	-2.75
40	-3.5	0	1.313	-3.5
41	-0.5	1.5	3.75	-0.5
42	-2	1.5	4.5	-2
43	-3.5	1.5	3.75	-3.5
44	-0.5	3	4.375	-0.5
45	-2	3	5.25	-2
46	-3.5	3	4.375	-3.5
211	3	11	8	3
212	3	9	8	3
213	3	7	8	3
214	3	5	8	3
215	1	11	8	1
216	1	9	8	1
217	1	7	8	1
218	1	5	8	1
219	-1	11	8	-1
220	-1	9	8	-1
221	-1	7	8	-1
222	-1	5	8	-1
223	-3	11	8	-3
224	-3	9	8	-3
225	-3	7	8	-3
226	-3	5	8	-3

Configuration: 2C-12-0-8/24 Jet-Induced Pressure Increments Run 219

Point	3	4	5	6	7	8	9
h/Dw =	17.70	11.79	8.85	5.89	4.71	3.55	2.36
Total Thrust =	53.07	52.37	52.08	51.96	52.22	52.15	52.25
NPR Front =	2.05	2.03	2.02	2.02	2.03	2.03	2.01
NPR Aft =	2.03	2.01	2.00	2.00	2.00	2.00	2.00
X-loc	ACP	ACP	ACP	ACP	ACP	ACP	ACP
Y-loc	ACP	ACP	ACP	ACP	ACP	ACP	ACP
1.50	0.00	-0.000137	-0.000223	-0.000279	-0.000505	-0.002685	-0.006064
2.75	0.00	-0.000108	-0.000192	-0.000320	-0.000350	-0.001860	-0.006552
2.00	0.00	-0.000196	-0.000243	-0.000434	-0.000990	-0.001313	-0.002105
1.25	0.00	-0.000269	-0.000554	-0.001096	-0.002349	-0.003869	-0.005101
0.50	0.00	-0.000447	-0.000281	-0.001433	-0.004383	-0.006331	-0.010004
-0.50	0.00	-0.000113	-0.000516	-0.000923	-0.005132	-0.005211	-0.014544
-1.25	0.00	-0.000117	-0.000089	-0.001116	-0.004598	-0.003489	-0.015126
-2.00	0.00	-0.000225	-0.000188	-0.004419	-0.000325	-0.002014	-0.003490
-2.75	0.00	-0.000171	-0.000228	-0.000194	-0.000815	-0.001716	-0.002495
-3.50	0.00	-0.000117	-0.000353	-0.000174	-0.000815	-0.002312	-0.012814
3.50	1.50	-0.000132	-0.000134	-0.000199	-0.001099	-0.002063	-0.003511
2.00	1.50	-0.000132	-0.000134	-0.000199	-0.001099	-0.002063	-0.003511
0.50	1.50	-0.000132	-0.000134	-0.000199	-0.001099	-0.002063	-0.003511
-0.50	1.50	-0.000132	-0.000134	-0.000199	-0.001099	-0.002063	-0.003511
-1.25	1.50	-0.000132	-0.000134	-0.000199	-0.001099	-0.002063	-0.003511
-2.00	1.50	-0.000132	-0.000134	-0.000199	-0.001099	-0.002063	-0.003511
-2.75	1.50	-0.000132	-0.000134	-0.000199	-0.001099	-0.002063	-0.003511
-3.50	1.50	-0.000132	-0.000134	-0.000199	-0.001099	-0.002063	-0.003511
3.00	3.00	-0.000024	-0.000074	-0.001620	-0.004148	-0.001959	-0.002528
2.25	3.00	-0.000098	-0.000104	-0.000668	-0.000835	-0.000015	-0.003256
0.25	3.00	-0.000098	-0.000104	-0.000668	-0.000835	-0.000015	-0.003256
-0.25	3.00	-0.000122	-0.000218	-0.000523	-0.002779	-0.004635	-0.009553
-2.25	3.00	-0.000191	-0.000407	-0.000489	-0.000700	-0.001005	-0.002604
-3.50	3.00	-0.000145	-0.000352	-0.000259	-0.000620	-0.002029	-0.004984
1.00	5.00	-0.000191	-0.000240	-0.000650	-0.001791	-0.002154	-0.005807
1.00	5.00	-0.000145	-0.000160	-0.000682	-0.001813	-0.002307	-0.004208
-1.00	5.00	-0.000295	-0.000194	-0.000663	-0.000590	-0.002107	-0.005139
-3.00	5.00	-0.000150	-0.000249	-0.000169	-0.000728	-0.001837	-0.004428
1.00	7.00	-0.000104	-0.000147	-0.000313	-0.000745	-0.001204	-0.001971
-1.00	7.00	-0.000391	-0.000181	-0.000457	-0.001345	-0.001728	-0.002960
3.00	9.00	-0.000456	-0.000051	-0.000165	-0.000047	-0.001846	-0.003887
1.00	9.00	-0.000175	-0.000067	-0.000250	-0.000658	-0.000845	-0.001357
-1.00	9.00	-0.000212	-0.000110	-0.000038	-0.000968	-0.001386	-0.002115
-3.00	9.00	-0.000179	-0.000185	-0.000360	-0.000599	-0.001044	-0.003240
3.00	11.00	-0.000100	-0.000190	-0.000080	-0.000403	-0.001420	-0.002660
1.00	11.00	-0.000349	-0.000025	-0.000030	-0.000599	-0.000101	-0.000804
-1.00	11.00	-0.000204	-0.000008	-0.000089	-0.000437	-0.000621	-0.001269
-3.00	11.00	-0.000241	-0.000084	-0.000305	-0.000628	-0.001039	-0.002322

Force and Moment Summary

h/Dw =	17.70	11.79	8.85	5.89	4.71	3.55	2.36
Balance AL/T =	-0.008	-0.003	0.007	0.020	0.011	-0.017	-0.135
Pressure AL/T =	-0.008	-0.002	0.009	0.024	0.012	-0.020	-0.128
Balance AH/TDe =	0.001	-0.015	0.026	0.052	0.029	0.015	0.047
Pressure AH/TDe =	0.001	-0.002	0.010	0.006	0.004	0.013	0.024

Configuration: 2C-12-0-8/24 Jet-Induced Pressure Increments Run 220

Point	1	2	3	4	5	6	7
h/De =	17.68	11.80	8.84	5.88	4.71	3.52	2.34
Total Thrust =	137.15	137.08	137.00	137.00	136.96	136.97	136.96
NPR Pront =	4.00	4.00	3.99	3.99	3.99	3.99	3.99
NPR Aft =	3.99	3.99	3.98	3.98	3.98	3.98	3.98
X-loc	Y-loc	ACP	ACP	ACP	ACP	ACP	ACP
3.50	0.00	-0.000091	-0.000222	-0.000241	-0.000790	-0.001869	-0.005237
2.75	0.00	-0.000642	-0.000176	-0.000351	-0.000152	-0.001390	-0.006079
2.00	0.00	-0.000076	-0.000121	-0.000004	-0.000857	-0.000318	-0.0011039
1.25	0.00	-0.000045	-0.000131	-0.000093	0.002085	0.003574	0.004444
0.50	0.00	-0.000047	-0.000206	0.000571	0.003948	0.005094	0.008718
-0.50	0.00	-0.000132	-0.000178	0.000273	0.002922	0.005124	0.009345
-1.25	0.00	-0.000081	-0.000019	0.000233	0.002322	0.003532	0.004440
-2.00	0.00	-0.000034	-0.000100	0.000303	0.000851	0.000417	-0.001018
-2.75	0.00	-0.000087	-0.000153	-0.000299	-0.000540	-0.001301	-0.005838
-3.50	0.00	-0.000089	-0.000112	-0.000353	-0.000929	-0.001485	-0.004920
2.00	1.50	-0.000089	-0.000112	-0.000353	-0.000929	-0.001485	-0.004920
0.50	1.50	-0.000048	-0.000021	0.000281	0.002881	0.005255	0.008791
-0.50	1.50	-0.000100	-0.000129	-0.000378	-0.000735	-0.001027	-0.002191
-2.00	1.50	-0.000121	-0.000129	-0.000227	-0.000433	-0.002010	-0.004953
-2.75	1.50	-0.000108	-0.000136	-0.000282	-0.000433	-0.002010	-0.004953
-3.50	3.00	-0.000044	-0.000021	0.000116	0.000895	0.002312	0.003709
2.00	3.00	-0.000116	-0.000133	-0.000161	0.000895	0.002312	0.003709
0.50	3.00	-0.000083	-0.000133	-0.000161	0.000895	0.002312	0.003709
-0.50	3.00	-0.000114	-0.000216	-0.000245	-0.000394	-0.001805	-0.004510
-2.00	3.00	-0.000089	-0.000197	-0.000367	-0.000849	-0.001805	-0.004510
-2.75	3.00	-0.000121	-0.000248	-0.000357	-0.000849	-0.001805	-0.004510
-3.50	5.00	-0.000098	-0.000106	-0.000248	-0.000357	-0.000849	-0.001805
1.00	5.00	-0.000093	-0.000072	-0.000177	0.000409	0.002131	0.003546
-1.00	5.00	-0.000105	-0.000314	-0.000396	-0.000845	-0.001694	-0.003863
-3.00	5.00	-0.000253	-0.000127	-0.000208	-0.000876	-0.001298	-0.002863
3.00	7.00	-0.000114	-0.000253	-0.000182	0.000761	0.001641	0.002383
-1.00	7.00	-0.000079	-0.000108	-0.000290	-0.000277	-0.001494	-0.003441
-3.00	7.00	-0.000124	-0.000222	-0.000401	-0.000672	-0.001494	-0.003441
3.00	9.00	-0.000151	-0.000008	-0.000393	-0.000728	-0.001310	-0.003208
-1.00	9.00	-0.000117	-0.000187	-0.000122	0.000747	0.000288	0.001657
-3.00	9.00	-0.000129	-0.000187	-0.000121	0.000681	0.000891	0.001490
3.00	9.00	-0.000138	-0.000124	-0.000325	-0.000473	-0.000357	-0.002311
-1.00	11.00	-0.000167	-0.000172	-0.000216	-0.000222	-0.001015	-0.001926
-3.00	11.00	-0.000251	-0.000187	-0.000047	-0.000024	0.000047	0.000505
3.00	11.00	-0.000177	-0.000224	-0.000071	0.000549	0.000536	0.003383
-3.00	11.00	-0.000177	-0.000122	-0.000235	-0.000507	-0.000800	-0.002345

Force and Moment Summary

h/De =	17.68	11.80	8.84	5.88	4.71	3.52	2.34
Balance AL/T =	-0.005	-0.005	-0.003	0.013	0.005	-0.025	-0.124
Pressure AL/T =	-0.005	-0.005	-0.006	0.011	0.011	-0.021	-0.111
Balance AH/TDe =	-0.015	-0.026	-0.016	-0.008	-0.001	-0.009	0.002
Pressure AH/TDe =	-0.000	0.001	0.001	0.007	0.006	0.019	0.039



Jet-Induced Pressure Increments  
 Configuration: 2C-12-0-8/24 Run 221

Point	1	2	3	4	5	6	7
h/D <sub>w</sub> =	17.67	11.79	8.85	5.90	4.71	3.54	2.35
Total Thrust =	226.46	226.04	226.43	226.39	225.96	226.16	225.92
NPR Front =	5.99	5.98	5.98	5.98	5.97	5.98	5.97
NPR Aft =	6.06	6.04	6.05	6.05	6.04	6.05	6.04
X-loc	ACP	ACP	ACP	ACP	ACP	ACP	ACP
Y-loc	ACP	ACP	ACP	ACP	ACP	ACP	ACP
3.50	0.00	-0.000112	-0.000144	-0.000162	-0.000631	-0.001644	-0.004445
2.75	0.00	-0.000104	-0.000157	-0.000407	-0.000144	-0.001527	-0.004491
2.00	0.00	-0.000092	-0.000068	-0.000049	-0.000068	-0.000874	-0.000635
1.25	0.00	-0.000072	-0.000045	-0.000109	-0.001285	-0.001964	-0.004957
0.50	0.00	-0.000084	-0.000083	-0.000304	-0.001552	-0.003489	-0.009267
-0.50	0.00	-0.000063	-0.000075	-0.000197	-0.001774	-0.003489	-0.008849
-1.25	0.00	-0.000062	-0.000057	-0.000138	-0.000531	-0.002362	-0.005063
-2.00	0.00	-0.000087	-0.000102	-0.000197	-0.000461	-0.000486	-0.001446
-2.75	0.00	-0.000115	-0.000361	-0.000074	-0.000603	-0.001153	-0.004355
-3.50	0.00	-0.000112	-0.000064	-0.000014	-0.000937	-0.001508	-0.004032
1.50	-0.000113	-0.000167	-0.000073	-0.000716	-0.001678	-0.004475	-0.009787
2.00	-0.000047	-0.000030	-0.000232	-0.001108	-0.003328	-0.008465	-0.009577
2.50	-0.000045	-0.000042	-0.000389	-0.000923	-0.003782	-0.009565	-0.016570
3.00	-0.000135	-0.000086	-0.000145	-0.000160	-0.000742	-0.002833	-0.016511
3.50	-0.000135	-0.000086	-0.000145	-0.000160	-0.000742	-0.002833	-0.016511
4.00	-0.000102	-0.000121	-0.000232	-0.001108	-0.003328	-0.008465	-0.016570
4.50	-0.000102	-0.000121	-0.000232	-0.001108	-0.003328	-0.008465	-0.016570
5.00	-0.000102	-0.000121	-0.000232	-0.001108	-0.003328	-0.008465	-0.016570
5.50	-0.000102	-0.000121	-0.000232	-0.001108	-0.003328	-0.008465	-0.016570
6.00	-0.000102	-0.000121	-0.000232	-0.001108	-0.003328	-0.008465	-0.016570
6.50	-0.000102	-0.000121	-0.000232	-0.001108	-0.003328	-0.008465	-0.016570
7.00	-0.000102	-0.000121	-0.000232	-0.001108	-0.003328	-0.008465	-0.016570
7.50	-0.000102	-0.000121	-0.000232	-0.001108	-0.003328	-0.008465	-0.016570
8.00	-0.000102	-0.000121	-0.000232	-0.001108	-0.003328	-0.008465	-0.016570
8.50	-0.000102	-0.000121	-0.000232	-0.001108	-0.003328	-0.008465	-0.016570
9.00	-0.000102	-0.000121	-0.000232	-0.001108	-0.003328	-0.008465	-0.016570
9.50	-0.000102	-0.000121	-0.000232	-0.001108	-0.003328	-0.008465	-0.016570
10.00	-0.000102	-0.000121	-0.000232	-0.001108	-0.003328	-0.008465	-0.016570
10.50	-0.000102	-0.000121	-0.000232	-0.001108	-0.003328	-0.008465	-0.016570
11.00	-0.000102	-0.000121	-0.000232	-0.001108	-0.003328	-0.008465	-0.016570
11.50	-0.000102	-0.000121	-0.000232	-0.001108	-0.003328	-0.008465	-0.016570
12.00	-0.000102	-0.000121	-0.000232	-0.001108	-0.003328	-0.008465	-0.016570

Force and Moment Summary

h/D <sub>w</sub> =	17.67	11.79	8.85	5.90	4.71	3.54	2.35
Balance	AL/T =	-0.004	-0.005	-0.006	-0.001	-0.000	-0.003
Pressure	DL/T =	-0.005	-0.005	-0.005	-0.003	0.002	0.001
Balance	AM/De =	-0.024	-0.017	-0.011	-0.005	-0.012	0.005
Pressure	DM/De =	-0.000	0.000	0.002	0.007	0.004	0.044

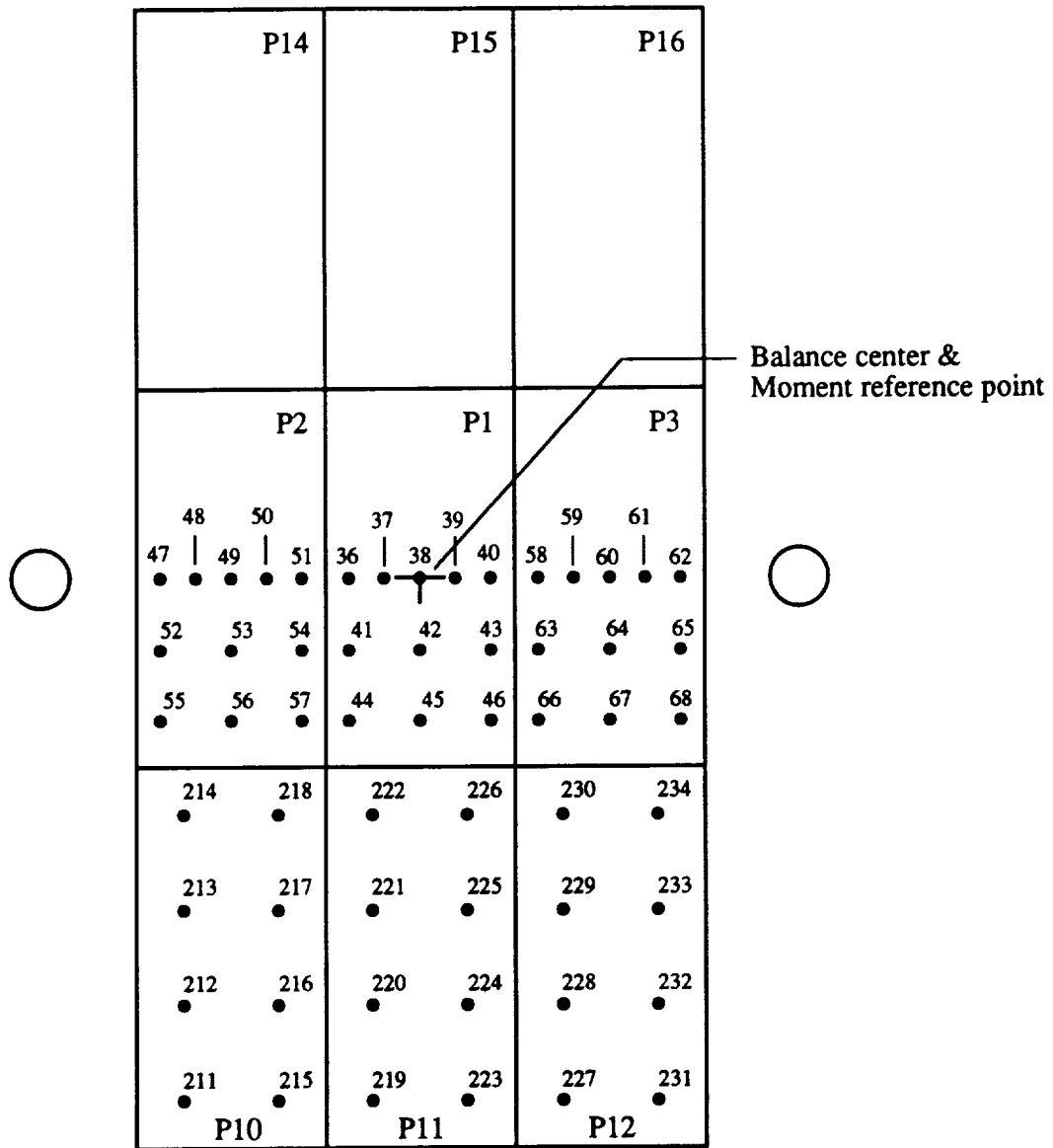

Figure 62. Configuration 2C\_16\_0\_12/24;  $D_e = 1.697$  in.,  $A_{jet} = 2.26$  in.<sup>2</sup>.

Pressure Orifice Locations and Weighting Factors

Conf. # 2C\_16\_0\_12/24

Distance from balance center to moment reference point,  $X_0 = 0$

Orif. #	Mom. arm	Sta. y	$\Delta$ .Area	Sta. x
47	5.5	0	1.313	5.5
48	4.75	0	1.125	4.75
49	4	0	1.125	4
50	3.25	0	1.125	3.25
51	2.5	0	1.313	2.5
52	5.5	1.5	3.75	5.5
53	4	1.5	4.5	4
54	2.5	1.5	3.75	2.5
55	5.5	3	4.375	5.5
56	4	3	5.25	4
57	2.5	3	4.375	2.5
36	1.5	0	1.313	1.5
37	0.75	0	1.125	0.75
38	0	0	1.125	0
39	-0.75	0	1.125	-0.75
40	-1.5	0	1.313	-1.5
41	1.5	1.5	3.75	1.5
42	0	1.5	4.5	0
43	-1.5	1.5	3.75	-1.5
44	1.5	3	4.375	1.5
45	0	3	5.25	0
46	-1.5	3	4.375	-1.5
58	-2.5	0	1.313	-2.5
59	-3.25	0	1.125	-3.25
60	-4	0	1.125	-4
61	-4.75	0	1.125	-4.75
62	-5.5	0	1.313	-5.5
63	-2.5	1.5	3.75	-2.5
64	-4	1.5	4.5	-4
65	-5.5	1.5	3.75	-5.5
66	-2.5	3	4.375	-2.5
67	-4	3	5.25	-4
68	-5.5	3	4.375	-5.5
211	5	11	8	5
212	5	9	8	5
213	5	7	8	5
214	5	5	8	5
215	3	11	8	3
216	3	9	8	3
217	3	7	8	3
218	3	5	8	3
219	1	11	8	1
220	1	9	8	1
221	1	7	8	1
222	1	5	8	1
223	-1	11	8	-1

Conf. # 2C\_16\_0\_12/24, continued

Orif. #	Mom. arm	Sta. y	$\Delta$ .Area	Sta. x
224	-1	9	8	-1
225	-1	7	8	-1
226	-1	5	8	-1
227	-3	11	8	-3
228	-3	9	8	-3
229	-3	7	8	-3
230	-3	5	8	-3
231	-5	11	8	-5
232	-5	9	8	-5
233	-5	7	8	-5
234	-5	5	8	-5



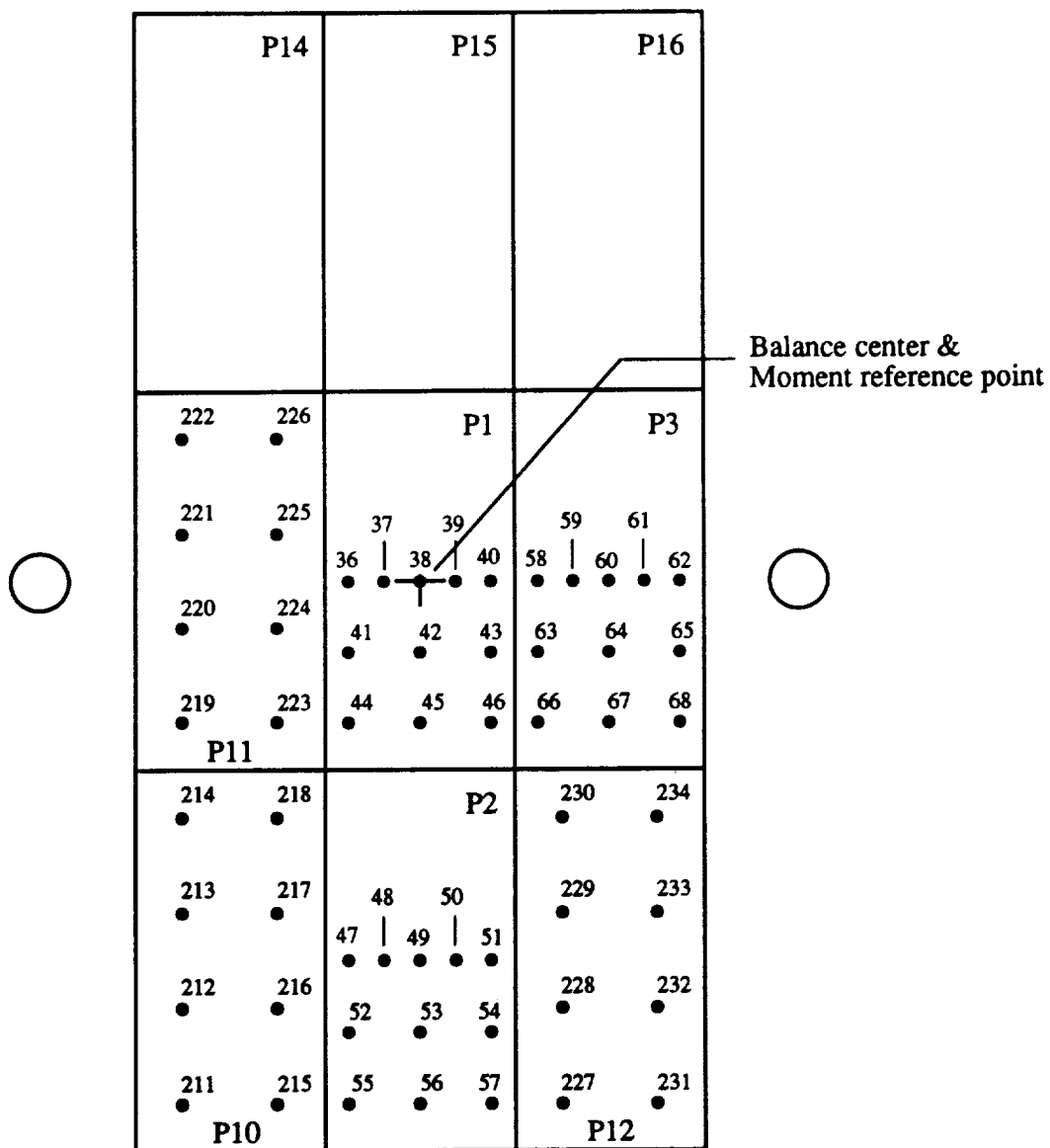

Figure 63. Configuration 2C\_16\_0\_12/24X;  $D_e = 1.697$  in.,  $A_{jet} = 2.26$  in.<sup>2</sup>.

Pressure Orifice Locations and Weighting Factors

Conf. # 2C\_16\_0\_12/24X

Distance from balance center to moment reference point,  $X_o = 0$

Orif. #	Mom. arm	Sta. y	$\Delta$ .Area	Sta. x
219	5	3	8	5
220	5	1	8	5
221	5	-1	0	5
222	5	-3	0	5
223	3	3	8	3
224	3	1	8	3
225	3	-1	0	3
226	3	-3	0	3
36	1.5	0	1.313	1.5
37	0.75	0	1.125	0.75
38	0	0	1.125	0
39	-0.75	0	1.125	-0.75
40	-1.5	0	1.313	-1.5
41	1.5	1.5	3.75	1.5
42	0	1.5	4.5	0
43	-1.5	1.5	3.75	-1.5
44	1.5	3	8.125	1.5
45	0	3	9.75	0
46	-1.5	3	8.125	-1.5
58	-2.5	0	1.313	-2.5
59	-3.25	0	1.125	-3.25
60	-4	0	1.125	-4
61	-4.75	0	1.125	-4.75
62	-5.5	0	1.313	-5.5
63	-2.5	1.5	3.75	-2.5
64	-4	1.5	4.5	-4
65	-5.5	1.5	3.75	-5.5
66	-2.5	3	4.375	-2.5
67	-4	3	5.25	-4
68	-5.5	3	4.375	-5.5
211	5	11	8	5
212	5	9	8	5
213	5	7	8	5
214	5	5	8	5
215	3	11	8	3
216	3	9	8	3
217	3	7	8	3
218	3	5	8	3
47	1.5	8	5.69	1.5
48	0.75	8	4.875	0.75
49	0	8	4.875	0
50	-0.75	8	4.875	-0.75
51	-1.5	8	5.69	-1.5
52	1.5	9.5	3.75	1.5
53	0	9.5	4.5	0
54	-1.5	9.5	3.75	-1.5

Conf. # 2C\_16\_0\_12/24X, continued

Orif. #	Mom. arm	Sta. y	$\Delta$ .Area	Sta. x
55	1.5	11	4.375	1.5
56	0	11	5.25	0
57	-1.5	11	4.375	-1.5
227	-3	11	8	-3
228	-3	9	8	-3
229	-3	7	8	-3
230	-3	5	8	-3
231	-5	11	8	-5
232	-5	9	8	-5
233	-5	7	8	-5
234	-5	5	8	-5



Configuration: 2C-16-0-12/24X Jet-Induced Pressure Increments Run 223

Point	2	3	4	5	6	7	8
Total Thrust =	17.70	11.79	8.84	5.86	4.68	3.52	2.36
NPR Front =	51.68	51.22	51.04	51.85	51.84	51.77	51.76
NPR Aft =	2.03	2.02	2.02	2.01	2.01	2.01	2.01
X-loc	1.99	1.98	1.97	2.01	2.01	2.01	2.01
Y-loc	ACP	ACP	ACP	ACP	ACP	ACP	ACP
5.00	-0.000209	-0.000314	-0.000830	-0.002369	-0.003910	-0.005667	-0.008212
3.00	-0.000226	-0.000665	-0.001104	-0.002544	-0.004242	-0.006557	-0.012907
5.00	-0.000226	-0.000245	-0.001184	-0.002276	-0.003970	-0.006046	-0.009096
3.00	-0.000231	0.000465	0.000419	0.000838	0.002468	0.005751	0.013571
1.50	-0.000231	0.000355	0.001654	0.003390	0.003531	0.000772	-0.001314
0.75	-0.000146	0.000618	0.002162	0.003821	0.005229	0.006641	0.010896
0.00	-0.000201	0.000958	0.001862	0.004492	0.007279	0.008851	0.014051
-0.75	-0.000131	0.000534	0.002365	0.004236	0.006297	0.005918	0.011036
-1.50	-0.000191	0.000634	0.001710	0.004187	0.003281	0.002237	-0.001871
-2.50	-0.000100	0.000471	0.001155	0.000441	-0.000311	-0.003726	-0.011926
-4.00	-0.000025	-0.000324	-0.001163	-0.002289	-0.003872	-0.007036	-0.012662
-4.75	-0.000020	-0.000336	-0.000631	-0.002174	-0.003842	-0.006174	-0.012800
5.00	-0.000005	-0.000213	-0.000539	-0.001948	-0.002640	-0.003741	-0.005865
5.00	-0.000209	-0.000207	-0.000687	-0.002339	-0.003592	-0.006160	-0.009218
1.00	0.000077	0.000250	0.000778	0.002408	0.001668	0.005671	0.013116
1.50	0.000030	0.000401	0.001593	0.003615	0.003501	0.002106	-0.000381
0.00	0.000000	0.000715	0.003199	0.004437	0.003216	0.002237	0.002257
1.50	0.000161	0.000477	0.002295	0.002443	0.003216	0.002237	0.002257
-1.50	0.000470	-0.000010	-0.000422	-0.001908	-0.003842	-0.004494	-0.012678
-2.00	0.000432	-0.000010	-0.000422	-0.001908	-0.003842	-0.004494	-0.012678
-4.00	-0.000045	-0.000223	-0.000783	-0.001532	-0.002750	-0.003622	-0.004817
-5.00	-0.000196	-0.000517	-0.000523	-0.002059	-0.003906	-0.005952	-0.008664
3.00	-0.000119	0.000177	0.000462	0.000934	0.002072	0.006353	0.013326
3.00	-0.000880	0.000395	0.001282	0.003395	0.002370	0.002458	-0.002644
1.50	-0.000146	0.000517	0.002511	0.004762	0.005325	0.007990	0.013177
0.00	-0.000880	0.000401	0.001511	0.002634	0.002540	0.001570	-0.004229
-1.50	-0.000036	-0.000137	-0.000097	-0.000411	-0.000366	-0.004474	-0.011909
-2.50	-0.000136	-0.000137	-0.000097	-0.000411	-0.000366	-0.004474	-0.011909
-4.00	-0.000110	-0.000112	-0.000473	-0.001657	-0.002284	-0.003115	-0.004019
-5.00	-0.000081	-0.000082	-0.000726	-0.002178	-0.003417	-0.005722	-0.007458
3.00	-0.000124	0.000151	0.000074	0.000217	0.003225	0.006821	0.011954
5.00	-0.000124	0.000396	0.000696	0.000978	0.002549	0.006387	0.011954
5.00	-0.000205	-0.000500	-0.000290	-0.002305	-0.003161	-0.005283	-0.006721
7.00	-0.000255	-0.000556	-0.000717	-0.002135	-0.002893	-0.005108	-0.005584
3.00	-0.000265	-0.000138	-0.000022	-0.000468	-0.001949	-0.005262	-0.010267
7.00	-0.000107	-0.000202	-0.000873	-0.002722	-0.004128	-0.005508	-0.009506
-1.50	-0.000040	-0.000406	0.001221	0.000811	0.000611	0.001204	-0.000381
0.75	-0.000156	0.000172	0.001149	0.002023	0.002044	0.003681	0.005529
8.00	-0.000555	0.000304	0.003387	0.002304	0.003050	0.005191	0.008851
0.00	-0.000105	0.000461	0.001470	0.001252	0.002371	0.003807	0.006201
-1.50	-0.000226	0.000284	0.000499	0.001252	0.002033	0.001791	0.000115
5.00	-0.000213	-0.000146	-0.000333	-0.001544	-0.002536	-0.004427	-0.005387
3.00	-0.000235	-0.000039	-0.000380	-0.000957	-0.002119	-0.004695	-0.007070
5.00	-0.000201	-0.000086	-0.000039	-0.001042	-0.002115	-0.004222	-0.006460
-2.00	-0.000080	-0.000280	0.000704	0.001842	0.003145	0.004572	0.006264
5.00	-0.000080	0.000096	0.001246	0.000546	0.000526	0.000522	-0.001214
5.00	-0.000386	0.000294	0.004768	0.001348	0.000526	0.000522	-0.001214
-1.50	-0.000556	-0.000039	-0.000432	-0.001493	-0.002013	-0.003519	-0.003311
3.00	-0.000103	-0.000086	0.000302	0.000999	0.001775	0.003268	0.005063
3.00	-0.000103	-0.000086	0.000302	0.000999	0.001775	0.003268	0.005063
1.50	-0.000071	0.000294	0.000768	0.001107	0.001348	0.000978	0.001756
0.00	-0.000071	0.000174	0.000264	0.001392	0.001803	0.003796	0.006181
-1.50	-0.000041	0.000172	0.000264	0.001392	0.001803	0.003796	0.006181
-3.00	-0.000043	0.000327	0.000566	-0.001208	-0.001298	-0.003016	-0.003737
-5.00	-0.000098	-0.000090	-0.000281	-0.001135	-0.001868	-0.003106	-0.003522

Force and Moment Summary

n/Da =	17.70	11.79	8.84	5.86	4.68	3.52	2.36
Balance AL/T =	-0.006	0.006	0.020	-0.001	-0.001	-0.016	-0.028
Pressure AL/T =	-0.007	0.006	0.023	-0.006	-0.006	-0.015	-0.028
Balance DM/TDe =	-0.007	-0.102	-0.041	0.006	-0.006	-0.072	-0.132
Pressure DM/TDe =	-0.007	-0.003	-0.002	0.009	-0.004	-0.022	-0.033

Configuration: 2C-16-0-12/24X Jet-Induced Pressure Increments Run 224

Point	1	2	3	4	5	6	7
Total Thrust =	17.70	11.79	8.83	5.88	4.69	3.51	2.31
h/De =	137.33	137.02	136.91	137.14	137.16	137.13	137.14
NER Front =	4.01	3.99	3.98	3.99	3.99	3.99	3.99
NER Aft =	4.01	4.01	4.01	4.02	4.02	4.01	4.01
X-loc	Y-loc	ACP	ACP	ACP	ACP	ACP	ACP
5.00	-3.00	-0.000035	0.000063	-0.000500	-0.001916	-0.003648	-0.005561
3.00	-3.00	-0.000079	0.000222	0.000741	-0.000666	-0.001836	-0.005832
5.00	-1.00	-0.000194	-0.000119	-0.000508	-0.002030	-0.003658	-0.005805
3.00	-1.00	-0.000082	0.000697	0.000516	-0.000971	-0.002134	-0.005845
1.50	0.00	-0.000015	-0.000011	0.001864	0.002346	0.003372	0.001727
0.75	0.00	-0.000157	-0.000498	0.001807	0.003978	0.005305	0.007341
0.00	0.00	-0.000028	0.000110	0.001252	0.004001	0.005562	0.008598
-0.75	0.00	-0.000136	0.000311	0.001157	0.003665	0.005361	0.006232
-1.50	0.00	-0.000113	0.000081	0.000833	0.003139	0.003385	0.002850
-2.50	0.00	-0.000157	-0.000203	0.000305	0.000967	0.000955	-0.003345
-3.25	0.00	-0.000159	-0.000262	-0.000563	-0.001734	-0.003779	-0.006862
-4.00	0.00	-0.000157	-0.000264	-0.000400	-0.002435	-0.003700	-0.004053
-4.75	0.00	-0.000161	-0.000248	-0.000636	-0.002139	-0.003866	-0.005667
-5.50	0.00	-0.000078	-0.000048	-0.000118	-0.000467	-0.001237	-0.004472
3.00	1.50	-0.000074	0.000232	0.001375	0.004827	0.003128	0.001598
1.50	1.50	-0.000059	0.000228	0.001375	0.004827	0.003128	0.001598
0.00	1.50	-0.000089	0.000297	0.001883	0.003883	0.005737	0.004918
-1.50	1.50	-0.000036	-0.000226	-0.000716	-0.002724	-0.004654	-0.003361
-2.50	1.50	-0.000098	-0.000289	-0.001157	-0.003729	-0.007007	-0.012673
-4.00	1.50	-0.000015	-0.000324	-0.000795	-0.001157	-0.003729	-0.003648
-5.00	1.50	-0.000057	-0.000302	-0.000562	-0.001393	-0.002590	-0.003648
5.00	3.00	-0.000084	-0.000005	-0.000442	-0.002316	-0.003751	-0.005664
3.00	3.00	-0.000061	0.000504	0.000442	0.002357	0.002459	0.001748
1.50	3.00	-0.000083	0.000290	0.000463	0.002318	0.005585	0.007305
0.00	3.00	-0.000113	0.000330	0.001324	0.002418	0.003573	0.003143
-1.50	3.00	-0.000113	0.000047	0.000392	0.002418	0.003573	0.003143
-2.50	3.00	-0.000123	0.000154	0.000175	0.000256	0.003647	0.006799
-4.00	3.00	-0.000115	-0.000432	-0.000719	-0.002325	-0.003491	-0.003437
-5.50	3.00	-0.000045	-0.000216	-0.000548	-0.001305	-0.003491	-0.004981
5.00	5.00	-0.000101	-0.000159	-0.000250	-0.001986	-0.003724	-0.005674
3.00	5.00	-0.000039	0.000101	0.000205	0.000531	0.001458	0.005000
1.50	5.00	-0.000162	0.000396	0.000627	0.001938	0.002822	0.004446
-3.00	5.00	-0.000188	-0.000423	-0.000627	-0.001938	-0.002822	-0.004446
-5.00	5.00	-0.000087	-0.000213	-0.000240	-0.001140	-0.002455	-0.005231
3.00	7.00	-0.000165	0.000296	0.000467	0.001140	0.002455	0.005231
-3.00	7.00	-0.000106	-0.000037	-0.000240	-0.000635	-0.002842	-0.005789
-5.00	7.00	-0.000106	-0.000315	-0.000857	-0.002375	-0.003843	-0.005777
1.50	8.00	-0.000074	0.000188	0.000596	0.001327	0.000653	0.005777
0.75	8.00	-0.000117	0.000165	0.000823	0.001942	0.002311	0.003646
0.00	8.00	-0.000102	0.000091	0.000392	0.001925	0.003250	0.004074
-0.75	8.00	-0.000006	-0.000248	0.001068	0.001460	0.001554	0.004161
-1.50	8.00	-0.000108	-0.000360	0.000205	0.000867	0.001124	0.001091
5.00	9.00	-0.000114	-0.000204	-0.000322	-0.001765	-0.002487	-0.003048
3.00	9.00	-0.000188	-0.000153	-0.000006	-0.000637	-0.001798	-0.003048
-3.00	9.00	-0.000132	-0.000006	-0.000101	-0.000677	-0.001972	-0.004337
-5.00	9.00	-0.000124	-0.000013	-0.000752	-0.001711	-0.003128	-0.004634
1.50	9.50	-0.000004	0.000421	0.000489	0.000811	0.000627	0.000275
0.00	9.50	-0.000004	0.000421	0.000489	0.000811	0.000627	0.000275
-1.50	9.50	-0.000197	-0.000193	0.000230	0.000871	0.001054	0.000890
5.00	11.00	-0.000167	-0.000097	-0.000369	-0.001029	-0.001671	-0.002673
3.00	11.00	-0.000132	-0.000153	0.000013	-0.000994	0.001594	0.000301
1.50	11.00	-0.000197	-0.000193	0.000230	0.000871	0.001054	0.000890
0.00	11.00	-0.000157	-0.000017	0.000171	0.000504	0.001113	0.002388
-1.50	11.00	-0.000157	-0.000017	0.000171	0.000504	0.001113	0.002388
-3.00	11.00	-0.000145	-0.000211	-0.000312	-0.000914	-0.001392	-0.002807
-5.00	11.00	-0.000132	-0.000169	-0.000267	-0.001079	-0.001845	-0.002950

Force and Moment Summary

Balance	h/De =	17.70	11.79	8.83	5.88	4.69	3.51	2.31
Pressure	AL/T =	-0.006	-0.004	0.009	-0.002	-0.044	-0.120	-0.252
Pressure	AM/T =	-0.006	-0.002	0.005	-0.011	-0.044	-0.128	-0.266
Pressure	AM/TDe =	-0.024	0.010	0.007	-0.021	-0.047	-0.047	-0.036
Pressure	AM/TDe =	0.000	0.012	0.014	-0.007	0.002	-0.013	-0.019

Configuration: 2C-16-0-12/24X  
 Jet-Induced Pressure Increments  
 Run 225

Point	1	2	3	4	5	6	7
h/De =	17.68	11.76	8.86	5.89	4.71	3.53	2.92
Total Thrust =	226.43	226.47	226.38	226.35	226.37	226.37	226.29
NPR Front =	6.00	6.00	6.00	6.00	6.00	6.00	6.00
NPR A/C =	6.07	6.07	6.07	6.07	6.07	6.07	6.06
X-loc	Y-loc	ACP	ACP	ACP	ACP	ACP	ACP
5.00	-3.00	-0.00094	-0.000301	-0.00159	-0.001495	-0.00302	-0.005315
3.00	-3.00	-0.00034	0.00053	0.00233	-0.00683	-0.001494	-0.005229
5.00	-1.00	-0.00028	-0.000107	-0.00036	-0.001895	-0.003172	-0.005331
3.00	-1.00	0.000024	0.000409	0.000275	-0.001171	-0.001492	-0.005141
1.50	0.00	-0.000037	0.000032	0.000593	0.001124	0.003128	0.002852
0.75	0.00	-0.000026	-0.000175	0.001265	0.002731	0.004827	0.006465
0.00	0.00	-0.000068	0.000068	0.001309	0.003249	0.005487	0.008481
-0.75	0.00	-0.000047	0.000204	0.000767	0.002550	0.004811	0.007368
-1.50	0.00	-0.000102	0.000310	0.000508	0.001596	0.003151	0.002838
-2.50	0.00	-0.000132	-0.000505	0.000244	0.000772	0.000175	-0.002478
-4.00	0.00	-0.000158	-0.000338	0.000259	-0.001281	-0.002786	-0.006357
-4.75	0.00	-0.000156	-0.000338	-0.000367	-0.001773	-0.003651	-0.005784
-5.00	1.00	-0.000212	-0.000168	-0.000405	-0.001242	-0.002286	-0.003448
5.00	1.00	-0.000146	-0.000015	-0.000303	-0.001438	-0.003249	-0.005473
3.00	1.00	-0.000055	0.000039	0.000484	-0.000920	-0.001404	-0.004669
1.50	1.50	-0.000127	0.000050	0.001106	0.001652	0.002841	0.002472
0.00	1.50	-0.000081	-0.000054	0.000747	0.001739	0.005475	0.007398
-1.50	1.50	-0.000057	-0.000061	0.000514	0.002698	0.005475	0.007398
-2.50	1.50	-0.000195	-0.000212	0.000109	-0.001014	-0.002951	-0.003359
-4.00	1.50	-0.000141	-0.000312	-0.000446	-0.001322	-0.002783	-0.006245
-5.00	3.00	-0.000083	-0.000174	-0.000601	-0.001481	-0.002242	-0.003264
3.00	3.00	-0.000045	0.000118	0.000085	-0.000771	-0.001834	-0.005227
1.50	3.00	-0.000058	0.000129	0.000697	0.001536	0.002205	0.001757
0.00	3.00	-0.000132	0.000029	0.001032	0.002242	0.003045	0.008645
-1.50	3.00	-0.000061	-0.000499	0.000765	0.001616	-0.002195	-0.003039
-2.50	3.00	-0.000157	-0.000329	-0.00149	-0.000420	-0.000525	-0.002896
-4.00	3.00	-0.000120	-0.000369	-0.000600	-0.001646	-0.002987	-0.005884
-5.00	3.00	-0.000116	-0.000332	-0.000505	-0.001256	-0.002080	-0.003146
5.00	5.00	-0.000064	-0.000099	-0.000269	-0.001695	-0.002891	-0.005137
3.00	5.00	-0.000137	-0.000114	-0.000209	-0.001278	-0.001956	-0.005355
1.50	5.00	-0.000044	-0.000399	0.000257	-0.000594	-0.001407	-0.004474
0.00	5.00	-0.000008	-0.000133	0.000518	-0.001506	-0.002859	-0.004757
-1.50	5.00	-0.000140	-0.000045	-0.000243	-0.001539	-0.002393	-0.004282
-3.00	7.00	-0.000040	-0.000485	0.000243	-0.001079	-0.001776	-0.004827
-5.00	7.00	-0.000130	-0.000468	-0.000088	-0.000588	-0.001639	-0.004192
1.50	8.00	-0.000152	-0.000094	-0.000819	-0.002384	-0.003310	-0.006658
0.75	8.00	-0.000105	0.000288	0.000389	0.000969	0.000528	0.000652
-0.75	8.00	-0.000134	-0.000273	0.000467	0.000813	0.001745	0.003057
-1.50	8.00	-0.000091	-0.000010	0.000815	0.001055	0.002023	0.005112
5.00	9.00	-0.000132	-0.000118	0.000266	0.000610	0.001909	0.004796
-3.00	9.00	-0.000100	-0.000012	0.000122	-0.000958	0.000169	-0.001419
-5.00	9.00	-0.000127	-0.000335	-0.000031	-0.000302	-0.002031	-0.003852
1.50	9.50	-0.000109	0.000007	0.000166	-0.000861	-0.001850	-0.004482
0.00	9.50	-0.000109	0.000007	-0.000596	-0.001270	-0.002175	-0.004873
-1.50	9.50	-0.000076	-0.000260	0.000345	0.000016	0.000559	0.000673
5.00	11.00	-0.000022	-0.000044	0.000116	-0.000075	0.000147	0.000559
3.00	11.00	-0.000061	-0.000134	-0.000353	-0.000844	-0.001430	-0.002739
1.50	11.00	-0.000076	-0.000260	0.000116	-0.000543	-0.001350	-0.002653
0.00	11.00	-0.000144	0.000014	0.000266	0.000116	0.000147	0.000958
-1.50	11.00	-0.000122	-0.000411	0.000266	0.000818	0.000907	0.003559
-3.00	11.00	-0.000119	-0.000289	0.000094	-0.000500	-0.001142	-0.002657
-5.00	11.00	-0.000119	-0.000289	-0.000455	-0.000683	-0.001398	-0.002903

Force and Moment Summary

h/De =	17.68	11.78	8.86	5.89	4.71	3.53	2.92
Balance AL/T =	-0.007	-0.007	0.001	-0.016	-0.039	-0.102	-0.145
Pressure AL/T =	-0.006	-0.009	0.006	-0.017	-0.045	-0.111	-0.148
Balance AM/TDe =	-0.005	-0.002	0.006	-0.013	-0.008	-0.015	-0.045
Pressure AM/TDe =	0.003	0.016	0.011	-0.005	-0.008	-0.014	-0.020

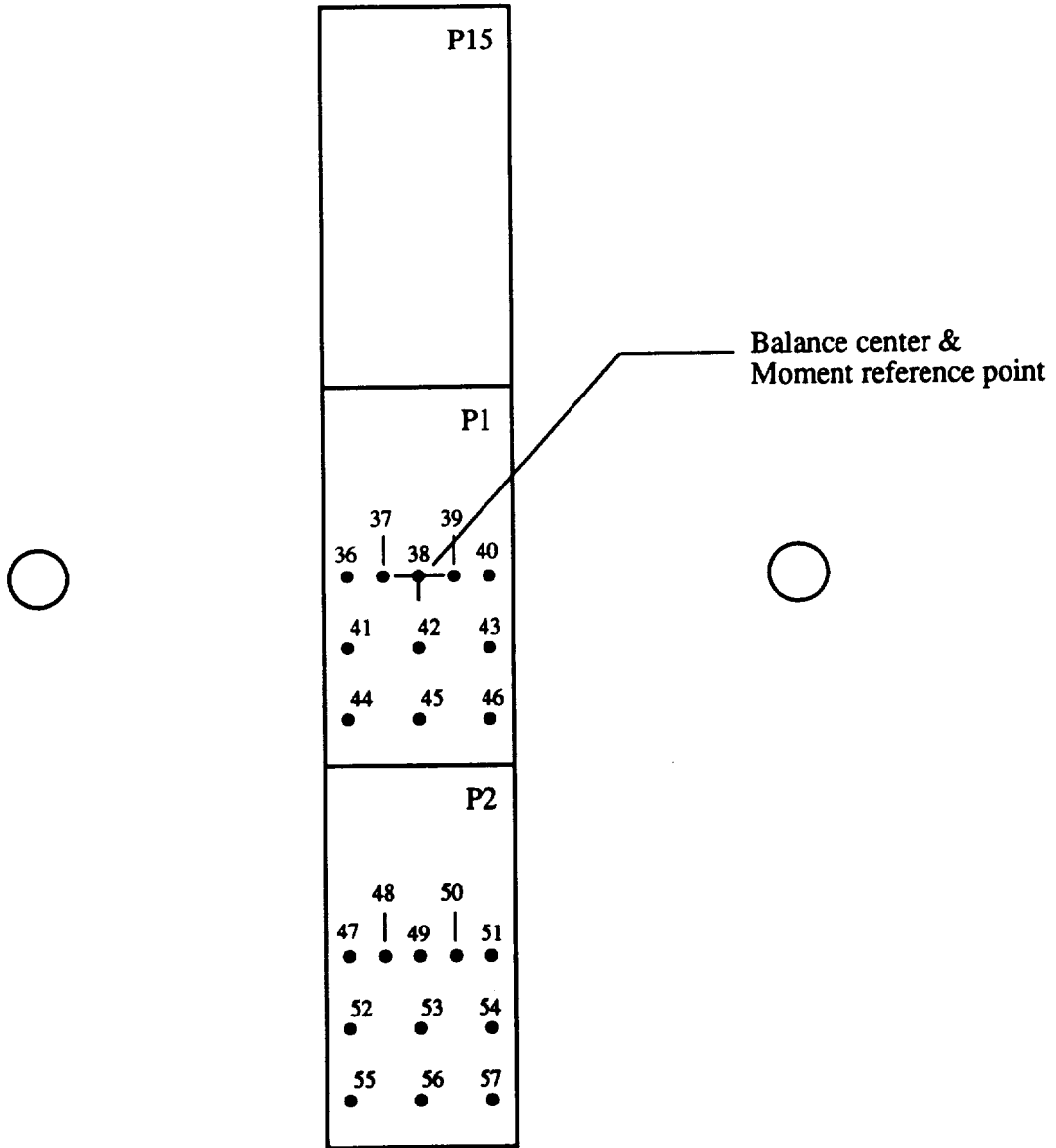

Figure 64. Configuration 2C\_16\_0\_4/24;  $D_e = 1.697$  in.,  $A_{jet} = 2.26$  in.<sup>2</sup>.

## Pressure Orifice Locations and Weighting Factors

Conf. # 2C\_16\_0\_4/24

Distance from balance center to moment reference point,  $X_o = 0$

Orif. #	Mom. arm	Sta. y	$\Delta$ .Area	Sta. x
36	1.5	0	1.313	1.5
37	0.75	0	1.125	0.75
38	0	0	1.125	0
39	-0.75	0	1.125	-0.75
40	-1.5	0	1.313	-1.5
41	1.5	1.5	3.75	1.5
42	0	1.5	4.5	0
43	-1.5	1.5	3.75	-1.5
44	1.5	3	8.125	1.5
45	0	3	9.75	0
46	-1.5	3	8.125	-1.5
47	1.5	8	5.69	1.5
48	0.75	8	4.875	0.75
49	0	8	4.875	0
50	-0.75	8	4.875	-0.75
51	-1.5	8	5.69	-1.5
52	1.5	9.5	3.75	1.5
53	0	9.5	4.5	0
54	-1.5	9.5	3.75	-1.5
55	1.5	11	4.375	1.5
56	0	11	5.25	0
57	-1.5	11	4.375	-1.5

Configuration: 2C-16-0-4/24 Jet-Induced Pressure Increments Run 226

Point	1	2	3	4	5	6	7
h/Ds =	17.70	11.78	8.84	5.88	4.70	3.52	2.33
Total Thrust =	51.46	52.48	52.41	52.40	52.40	52.72	52.31
NPR Front =	2.02	2.05	2.04	2.04	2.04	2.04	2.04
NPR Aft =	1.98	2.00	2.00	2.00	2.00	2.02	2.00
X-loc	Y-loc	ACP	ACP	ACP	ACP	ACP	ACP
1.50	0.00	-0.000076	0.000752	0.000322	0.002071	0.004375	0.003093
0.75	0.00	-0.000126	0.000346	0.001797	0.004440	0.006709	0.009447
0.00	0.00	0.000031	0.000569	0.002065	0.004019	0.006656	0.010373
-0.75	0.00	-0.000055	0.000673	0.002039	0.004603	0.006843	0.009335
-1.50	0.00	-0.000011	0.000292	0.001074	0.001541	0.003904	0.004428
1.50	1.50	-0.000111	0.000153	0.001084	0.003047	0.003166	0.003363
0.00	1.50	-0.000025	0.000252	0.001629	0.004187	0.007264	0.010511
-1.50	1.50	-0.000177	0.000297	0.000895	0.003211	0.003578	0.003122
1.50	3.00	-0.000116	0.000374	0.000639	0.002150	0.003161	0.003777
0.00	3.00	-0.000055	0.000356	0.000861	0.003900	0.007090	0.010785
-1.50	3.00	-0.000111	0.000292	0.000861	0.003900	0.003334	0.003280
1.50	8.00	-0.000187	0.000188	0.000495	0.000624	0.001516	0.001093
0.75	8.00	-0.000121	0.000465	0.000683	0.001496	0.003512	0.004555
0.00	8.00	-0.000025	0.000683	0.000287	0.001411	0.002665	0.005596
-0.75	8.00	-0.000096	0.000257	0.000787	0.002547	0.004817	0.005475
-1.50	8.00	-0.000182	0.000069	0.000515	0.002659	0.002012	0.002009
1.50	9.50	-0.000061	0.000099	0.000208	0.000574	0.000852	0.001241
0.00	9.50	-0.000061	0.000099	0.000208	0.000574	0.000852	0.001241
-1.50	9.50	-0.000121	-0.000114	0.000337	0.001243	0.001174	0.001708
0.00	11.00	-0.000021	-0.000114	0.000337	0.001243	0.001174	0.001708
1.50	11.00	0.000005	0.000282	0.000232	0.001239	0.001793	0.003250
-1.50	11.00	0.000005	0.000282	0.000232	0.001239	0.001793	0.003250

Force and Moment Summary

h/Ds =	17.70	11.78	8.84	5.88	4.70	3.52	2.33
Balance	ΔL/T =	0.001	0.008	0.017	0.040	0.067	0.086
Pressure	ΔL/T =	-0.002	0.005	0.015	0.043	0.069	0.084
Balance	ΔM/TDe =	-0.035	-0.032	-0.028	-0.022	-0.030	-0.028
Pressure	ΔM/TDe =	-0.000	-0.000	-0.001	-0.001	-0.002	-0.003

Jet-Induced Pressure Increments  
 Configuration: 2C-16-0-4/24 Run 227

Point	1	2	3	4	5	6	7
h/Dc =	17.71	11.80	8.83	5.88	4.71	3.52	2.34
Total Thrust =	138.23	138.28	138.13	138.01	137.97	138.03	138.03
NPR Front =	4.02	4.02	4.01	4.00	4.00	4.01	4.00
NPR Aft =	4.03	4.03	4.03	4.03	4.03	4.03	4.02
X-loc	ACP	ACP	ACP	ACP	ACP	ACP	ACP
Y-loc	ACP	ACP	ACP	ACP	ACP	ACP	ACP
1.50	0.000011	-0.000184	0.000053	0.001988	0.004323	0.003696	0.001501
0.75	0.000000	0.000147	0.001053	0.003112	0.005680	0.008569	0.011717
0.00	-0.000045	0.000178	0.000643	0.003571	0.005710	0.009497	0.015715
-0.75	0.000028	-0.000118	0.000032	0.003499	0.006247	0.008756	0.011372
-1.50	0.000058	-0.000203	0.000274	0.002162	0.003588	0.004105	0.001917
0.00	-0.000056	-0.000101	0.000305	0.002267	0.003849	0.003827	0.000707
1.50	-0.000022	0.000216	0.000584	0.004364	0.005879	0.008523	0.014414
0.75	-0.000043	-0.000212	0.000893	0.001593	0.003336	0.005235	0.008178
0.00	-0.000090	-0.000086	0.000092	0.001561	0.003213	0.002607	-0.000410
-0.75	-0.000051	0.000020	0.000582	0.002800	0.004819	0.005104	0.001426
-1.50	-0.000034	0.000105	0.000462	0.001505	0.002590	0.002565	0.000583
0.75	-0.000053	-0.000038	0.000432	0.000649	0.001907	0.001435	-0.000231
0.00	-0.000051	-0.000054	0.000545	0.001430	0.002422	0.004407	0.004821
0.75	-0.000028	-0.000024	0.000656	0.001936	0.003455	0.005544	0.007648
-0.75	-0.000043	-0.000024	0.000646	0.000920	0.002411	0.005032	0.005239
-1.50	-0.000030	-0.000017	0.000641	0.000978	0.001772	0.001982	0.000254
0.00	-0.000071	-0.000026	0.000282	0.000230	0.000841	0.001875	-0.000008
1.50	-0.000045	-0.000026	0.000252	0.000220	0.000841	0.001875	-0.000008
-1.50	-0.000045	-0.000045	0.000077	0.000122	0.000892	0.000578	0.000196
0.00	-0.000019	-0.000004	0.000077	0.000122	0.000892	0.000578	0.000196
1.50	-0.000019	-0.000004	0.000077	0.000122	0.000892	0.000578	0.000196
-1.50	-0.000019	-0.000004	0.000077	0.000122	0.000892	0.000578	0.000196
0.00	-0.000019	-0.000004	0.000077	0.000122	0.000892	0.000578	0.000196
-1.50	-0.000019	-0.000004	0.000077	0.000122	0.000892	0.000578	0.000196

Force and Moment Summary

h/Dc =	17.71	11.80	8.83	5.88	4.71	3.52	2.34
Balance ΔL/T =	-0.001	-0.001	0.007	0.033	0.058	0.087	0.087
Pressure ΔL/T =	-0.001	-0.000	-0.009	-0.033	-0.063	-0.088	-0.086
Balance ΔM/TDe =	-0.011	-0.008	-0.009	-0.007	-0.003	-0.003	-0.005
Pressure ΔM/TDe =	-0.000	-0.000	-0.001	-0.001	0.001	-0.003	-0.006





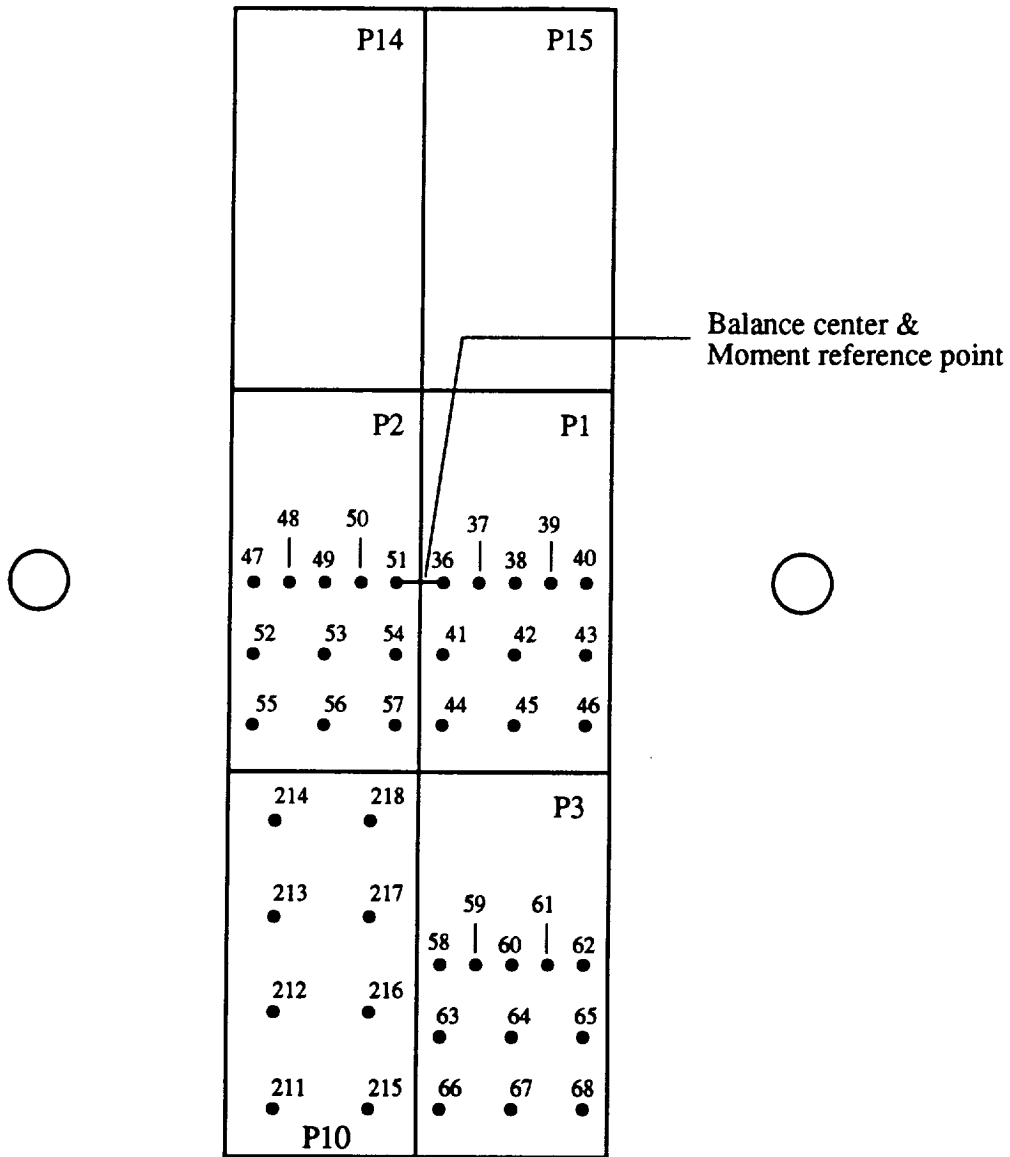

Figure 65. Configuration 2C\_16\_8\_8/24;  $D_e = 1.697$  in.,  $A_{jet} = 2.26$  in.<sup>2</sup>.

## Pressure Orifice Locations and Weighting Factors

Conf. # 2C\_16\_0\_8/24

Distance from balance center to moment reference point,  $X_0 = 0$

Orif. #	Mom. arm	Sta. y	$\Delta$ .Area	Sta. x
47	3.5	0	1.313	3.5
48	2.75	0	1.125	2.75
49	2	0	1.125	2
50	1.25	0	1.125	1.25
51	0.5	0	1.313	0.5
52	3.5	1.5	3.75	3.5
53	2	1.5	4.5	2
54	0.5	1.5	3.75	0.5
55	3.5	3	4.375	3.5
56	2	3	5.25	2
57	0.5	3	4.375	0.6
36	-0.5	0	1.313	-0.5
37	-1.25	0	1.125	-1.25
38	-2	0	1.125	-2
39	-2.75	0	1.125	-2.75
40	-3.5	0	1.313	-3.5
41	-0.5	1.5	3.75	-0.5
42	-2	1.5	4.5	-2
43	-3.5	1.5	3.75	-3.5
44	-0.5	3	8.125	-0.5
45	-2	3	9.75	-2
46	-3.5	3	8.125	-3.5
211	3	11	8	3
212	3	9	8	3
213	3	7	8	3
214	3	5	8	3
215	1	11	8	1
216	1	9	8	1
217	1	7	8	1
218	1	5	8	1
58	-0.5	8	5.69	-0.5
59	-1.25	8	4.875	-1.25
60	-2	8	4.875	-2
61	-2.75	8	4.875	-2.75
62	-3.5	8	5.69	-3.5
63	-0.5	9.5	3.75	-0.5
64	-2	9.5	4.5	-2
65	-3.5	9.5	3.75	-3.5
66	-0.5	11	4.375	-0.5
67	-2	11	5.25	-2
68	-3.5	11	4.375	-3.5

Configuration: 2C-16-0-8/24 Jet-Induced Pressure Increments Run 229

Point	1	2	3	4	5	6	7
h/D <sub>e</sub>	17.69	11.79	8.83	5.90	4.70	3.52	2.32
Total Throat	51.72	51.74	51.99	51.91	51.86	51.86	51.86
NPR Front	2.02	2.03	2.05	2.04	2.04	2.04	2.04
NPR Aft	1.98	1.98	1.98	1.98	1.98	1.97	1.97
X-loc	Y-loc	ACP	ACP	ACP	ACP	ACP	ACP
3.50	0.00	-0.00085	0.000171	0.000145	-0.000520	-0.001615	-0.004401
2.75	0.00	-0.00085	0.000045	0.000090	-0.000520	-0.001721	-0.005062
2.00	0.00	-0.00010	0.000055	0.000524	0.002095	0.001631	-0.002038
1.25	0.00	-0.00010	0.000246	0.001428	0.003181	0.004772	0.003560
0.50	0.00	-0.00075	0.000738	0.002102	0.004720	0.007863	0.008810
-0.50	0.00	-0.00075	0.000552	0.002193	0.005306	0.006972	0.010354
-2.00	0.00	-0.00075	0.000607	0.002193	0.005306	0.006972	0.010354
-2.75	0.00	-0.00146	0.000632	0.001428	0.001855	0.001906	-0.000120
-3.50	0.00	-0.00100	0.000452	0.000964	0.000750	-0.000215	-0.004301
2.00	1.50	-0.00191	-0.000276	0.000315	-0.000405	-0.001556	-0.004431
2.00	1.50	-0.00186	0.000617	0.001688	0.004141	0.005707	0.008854
2.00	1.50	-0.00020	0.000652	0.001778	0.004656	0.005542	0.008556
-2.00	1.50	-0.00076	0.000502	0.001448	0.003546	0.001986	-0.000931
-3.50	3.00	-0.00070	0.000331	0.000639	-0.000365	-0.001540	-0.004466
2.00	3.00	-0.00085	0.000617	0.001688	0.004141	0.005707	0.008854
0.60	3.00	-0.00085	0.000030	-0.00045	0.001376	0.001040	-0.001687
-0.50	3.00	-0.00015	0.000211	0.001294	0.004805	0.006333	0.009046
-2.00	3.00	-0.00055	0.000557	0.001083	0.002420	0.001716	-0.001442
-3.50	3.00	-0.00158	-0.000094	-0.00008	-0.000374	-0.001487	-0.004368
1.00	5.00	-0.00015	0.000094	0.001345	-0.00239	0.003880	0.004206
3.00	7.00	-0.00017	-0.00043	0.00195	-0.00450	0.01109	-0.004253
1.00	7.00	-0.00017	0.000452	0.00518	0.02561	0.03867	0.04614
-0.50	8.00	-0.00090	0.000246	0.001369	0.001835	0.003271	0.007525
-1.25	8.00	-0.00035	0.000125	0.000679	0.000730	0.000360	0.000395
-2.75	8.00	-0.00120	0.000100	0.000769	-0.00075	-0.000530	-0.003024
-3.50	8.00	-0.00085	0.000221	0.000170	-0.00015	-0.001520	-0.003019
1.00	9.00	-0.000154	-0.000192	-0.000038	-0.000374	-0.001198	-0.003560
-0.50	9.50	-0.00080	0.000448	0.00271	0.02132	0.02685	0.03934
-2.00	9.50	-0.000171	0.000125	0.000734	0.001150	0.003496	0.005908
-3.50	9.50	-0.000276	-0.000030	0.000335	-0.000375	-0.001301	-0.003059
3.00	11.00	-0.00026	-0.000158	-0.000136	-0.000663	-0.001704	-0.002552
1.00	11.00	-0.00038	0.000345	0.000288	0.001333	0.001942	0.003496
-0.50	11.00	-0.000206	-0.000065	0.000480	0.001555	0.002546	0.004751
-2.00	11.00	-0.00090	-0.000065	0.000385	0.000500	-0.000175	-0.000245
-3.50	11.00	-0.000151	-0.000030	0.000140	-0.000415	-0.001215	-0.002273

Force and Moment Summary

Balance	h/D <sub>e</sub> = 17.69	11.79	8.83	5.90	4.70	3.52	2.32
Pressure	AL/T = -0.005	0.008	0.023	0.055	0.050	0.029	-0.078
Balance	AL/T = -0.004	0.008	0.026	0.055	0.054	0.032	-0.064
Pressure	AM/TDe = -0.004	-0.001	-0.002	-0.016	-0.003	-0.007	-0.007
Balance	AM/TDe = -0.001	-0.006	-0.009	-0.004	0.007	0.007	0.003

Configuration: 2C-16-0-8/24 Jet-Induced Pressure Increments  
Run 230

Point	1	2	3	4	5	6	7
Total Thrust =	17.69	11.80	8.85	5.88	4.71	3.53	2.35
NPR Front =	138.34	138.06	138.03	138.09	138.00	138.04	138.00
NPR Aft =	4.02	4.00	4.00	4.00	4.00	4.00	4.00
X-loc	4.02	4.02	4.02	4.02	4.02	4.02	4.02
Y-loc	ACP	ACP	ACP	ACP	ACP	ACP	ACP
3.50	0.000071	-0.000231	0.000096	-0.000431	-0.001503	-0.004047	-0.008234
2.75	0.000006	-0.000132	0.000378	0.000406	-0.000786	-0.004401	-0.011509
2.00	0.000005	0.000017	0.000805	0.002591	0.001769	-0.000720	-0.007470
1.25	0.000075	0.000497	0.000786	0.002727	0.003916	0.004549	0.002683
0.50	0.000090	0.000207	0.000880	0.003929	0.006410	0.008734	0.012543
-0.50	0.000169	0.000224	0.000393	0.003385	0.005994	0.008766	0.013923
-1.25	0.000004	0.000079	0.000799	0.003769	0.005253	0.004185	0.003682
-2.00	0.000004	0.000047	0.000604	0.003184	0.005152	0.004068	0.003682
-2.75	0.000135	0.000145	-0.000126	0.000775	0.000916	-0.004581	-0.010437
-3.50	0.000060	0.000181	0.000192	-0.000365	-0.001823	-0.004162	-0.007746
3.50	0.000118	0.000038	-0.000258	-0.000329	-0.001620	-0.003716	-0.007920
2.75	0.000036	0.000072	0.000660	-0.000339	0.006555	0.008353	0.012622
2.00	0.000073	0.000011	0.01097	0.003709	0.006266	0.008330	0.013477
-0.50	0.000053	0.000324	0.000160	0.001482	0.002173	-0.000995	-0.005904
-1.50	0.000167	0.000145	0.000149	-0.000339	-0.001253	-0.003811	-0.007992
-2.50	0.000336	0.000072	0.000660	0.003339	0.006555	0.008353	0.012622
3.50	0.000034	0.000303	0.000419	0.001937	0.001360	-0.001409	-0.007825
2.75	0.000060	0.000177	0.000948	0.003559	0.005847	0.009881	0.012094
2.00	0.000008	0.000126	-0.000442	0.000970	0.001533	-0.001025	-0.006759
-0.50	0.000052	-0.000195	0.000000	-0.000393	-0.001538	-0.004111	-0.009147
-1.50	0.000153	0.000238	0.000825	0.002209	0.004497	0.005771	0.004772
3.00	0.000073	0.000123	0.000123	-0.000286	-0.001306	-0.003245	-0.007731
1.00	0.000093	0.000264	0.000812	0.002562	0.003465	0.004908	0.004261
-0.50	0.000111	0.000221	0.000617	0.001796	0.003961	0.005984	0.007163
-1.25	0.000109	0.000098	0.000261	0.000426	0.000107	-0.001102	-0.004340
-2.00	0.000124	0.000115	-0.000186	0.000120	0.000775	-0.003531	-0.006880
-2.75	0.000137	0.000056	-0.000622	-0.00028	-0.001443	-0.003418	-0.005225
-3.50	0.000113	-0.000022	0.000232	-0.000171	-0.000209	-0.002132	-0.005228
3.00	0.00015	0.000152	0.000398	0.001369	0.002321	0.004118	0.004379
1.00	0.00028	0.00043	0.000544	0.000920	0.001328	0.004231	0.006337
-0.50	0.000021	0.000115	-0.000181	0.000079	-0.001130	-0.001189	-0.002038
-1.50	0.000159	0.000156	-0.000230	0.000496	-0.001334	-0.002286	-0.004445
-2.50	0.000099	0.000159	0.000136	0.000249	0.001002	-0.001902	-0.003840
3.00	0.000075	0.000161	0.000312	0.000883	0.001577	0.003699	0.003808
1.00	0.000094	0.000164	0.000056	0.000818	0.002062	0.003297	0.003843
-0.50	0.000019	0.000064	0.000105	-0.000021	-0.000295	-0.000619	-0.001603
-1.50	0.000144	-0.000002	-0.000252	-0.000446	-0.000905	-0.002314	-0.003097

Force and Moment Summary

Balance h/Dw =	17.69	11.80	8.85	5.88	4.71	3.53	2.35
Balance A1/T =	-0.005	0.001	0.011	0.040	0.046	0.024	-0.066
Balance A1/T =	-0.003	0.002	0.013	0.042	0.057	0.037	-0.069
Balance Δh/TDw =	0.003	0.004	0.008	0.007	0.006	0.008	0.003
Balance Δh/TDw =	0.000	-0.001	0.005	0.006	0.013	0.026	0.021

Configuration: 2C-16-0-8/24 Jet-Induced Pressure Increments Run 231

Point 1 2 3 4 5  
 h/D<sub>e</sub> = 2.37 3.52 4.71 5.92 8.86  
 Total Thrust = 226.46 226.48 226.49 226.44 226.44  
 NPR Front = 5.98 5.98 5.98 5.98 5.98  
 NPR Aft = 6.06 6.06 6.06 6.06 6.06  
 X-loc Y-loc ACP ACP ACP ACP ACP

3.50	0.00	-0.006835	-0.003862	-0.001554	-0.000078	0.000249
2.75	0.00	-0.009651	-0.004082	-0.000668	-0.000205	0.000346
2.00	0.00	-0.005498	-0.000564	-0.001967	0.001260	0.000181
1.25	0.00	0.003711	0.003482	0.004533	0.002083	0.000610
0.50	0.00	0.012125	0.008534	0.005672	0.002816	0.000507
-0.50	0.00	0.012153	0.008420	0.005596	0.002638	0.000844
-1.25	0.00	0.002730	0.003682	0.003545	0.001916	0.000342
-2.00	0.00	-0.005990	-0.001134	-0.001827	0.001350	0.000624
-2.75	0.00	-0.009473	-0.004006	-0.004084	-0.000344	0.000248
-3.50	0.00	-0.006892	-0.003878	-0.001612	-0.000365	-0.000170
3.50	1.50	-0.006892	-0.003794	-0.001249	-0.000672	-0.000015
2.00	1.50	-0.006892	-0.003794	-0.001249	-0.000672	-0.000015
0.50	1.50	0.011154	0.007963	0.005203	0.002698	0.000456
-0.50	1.50	0.012211	0.008478	0.005838	0.003641	0.000733
-2.00	1.50	-0.005564	-0.00156	-0.001501	0.000790	0.000072
-3.50	1.50	-0.006749	-0.003695	-0.001182	-0.000368	-0.000274
3.50	3.00	0.011154	0.007963	0.005203	0.002698	0.000456
2.00	3.00	-0.006651	-0.001270	-0.001845	0.001269	0.000896
0.60	3.00	-0.006651	-0.001270	-0.001845	0.001269	0.000896
-0.50	3.00	0.011162	0.008242	0.005271	0.002236	0.000478
-2.00	3.00	-0.006527	-0.001199	-0.001604	0.000128	-0.000047
-3.50	3.00	-0.008383	-0.003505	-0.001262	-0.000574	-0.000062
1.00	5.00	-0.004849	-0.003390	-0.003876	0.0002313	0.000117
3.00	7.00	-0.006416	-0.004137	-0.001538	-0.000280	0.000128
1.00	7.00	-0.005550	0.004137	0.001990	0.001578	0.000242
-0.50	8.00	0.007029	0.006508	0.003537	0.001414	0.000256
-1.25	8.00	-0.007029	-0.006508	-0.003537	-0.001414	-0.000256
-2.00	8.00	-0.004126	-0.000077	0.000026	0.000159	-0.000044
-2.75	8.00	-0.005808	-0.002872	-0.000966	-0.000056	-0.000068
-3.50	8.00	-0.004581	-0.002798	-0.001004	-0.000380	-0.000326
1.00	9.00	-0.004581	-0.002798	-0.001004	-0.000380	-0.000326
3.00	9.00	0.005344	0.004337	0.002124	0.001065	0.000485
-0.50	9.50	-0.002510	-0.000746	-0.000099	0.000539	-0.000228
-2.00	9.50	-0.005341	-0.002049	-0.000099	-0.000924	0.000246
-3.50	9.50	-0.01628	-0.002558	-0.000923	-0.000391	-0.000127
3.00	11.00	-0.002581	-0.001842	-0.000762	-0.000230	0.000030
1.00	11.00	0.004237	0.003302	0.001141	0.000830	0.000070
-0.50	11.00	0.004432	0.003844	0.001448	0.000401	-0.000094
-2.00	11.00	-0.001579	-0.001043	-0.000036	0.000286	-0.000130
-3.50	11.00	-0.002815	-0.002083	-0.000829	-0.000197	-0.000085

Force and Moment Summary  
 h/D<sub>e</sub> = 2.37 3.52 4.71 5.92 8.86  
 Balance ΔI/T = -0.043 0.029 0.048 0.027 0.007  
 Pressure ΔI/T = -0.020 0.036 0.029 0.029 0.006  
 Balance ΔM/TDe = 0.001 0.004 0.006 0.002 0.003  
 Pressure ΔM/TDe = 0.030 0.009 0.006 0.007 0.005

Balance center &  
Moment reference point

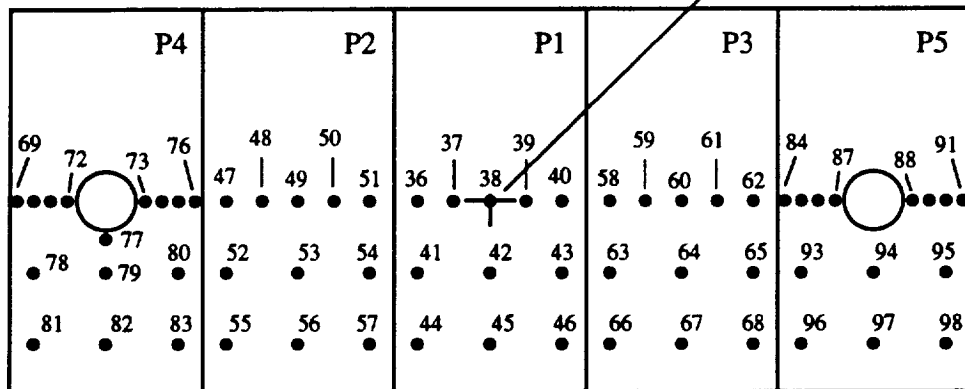

Figure 66. Configuration 2C\_16\_0\_20/8;  $D_e = 1.697$  in.,  $A_{jet} = 2.26$  in.<sup>2</sup>.

## Pressure Orifice Locations and Weighting Factors

Conf. # 2C\_16\_0\_20/8

Distance from balance center to moment reference point,  $X_0 = 0$

Orif. #	Mom. arm	Sta. y	$\Delta$ .Area	Sta. x
69	9.85	0	0.634	9.85
70	9.5	0	0.683	9.5
71	9.15	0	0.683	9.15
72	8.8	0	0.619	8.8
73	7.2	0	0.619	7.2
74	6.85	0	0.683	6.85
75	6.5	0	0.683	6.5
76	6.15	0	0.634	6.15
77	8	0.8	1.238	8
78	9.5	1.5	3.19	9.5
79	8	1.5	3.825	8
80	6.5	1.5	3.19	6.5
81	9.5	3	4.375	9.5
82	8	3	5.25	8
83	6.5	3	4.375	6.5
47	5.5	0	1.313	5.5
48	4.75	0	1.125	4.75
49	4	0	1.125	4
50	3.25	0	1.125	3.25
51	2.5	0	1.313	2.5
52	5.5	1.5	3.75	5.5
53	4	1.5	4.5	4
54	2.5	1.5	3.75	2.5
55	5.5	3	4.375	5.5
56	4	3	5.25	4
57	2.5	3	4.375	2.5
36	1.5	0	1.313	1.5
37	0.75	0	1.125	0.75
38	0	0	1.125	0
39	-0.75	0	1.125	-0.75
40	-1.5	0	1.313	-1.5
41	1.5	1.5	3.75	1.5
42	0	1.5	4.5	0
43	-1.5	1.5	3.75	-1.5
44	1.5	3	4.375	1.5
45	0	3	5.25	0
46	-1.5	3	4.375	-1.5
58	-2.5	0	1.313	-2.5
59	-3.25	0	1.125	-3.25
60	-4	0	1.125	-4
61	-4.75	0	1.125	-4.75
62	-5.5	0	1.313	-5.5
63	-2.5	1.5	3.75	-2.5
64	-4	1.5	4.5	-4
65	-5.5	1.5	3.75	-5.5
66	-2.5	3	4.375	-2.5

Conf. # 2C\_16\_0\_20/8, continued

Orif. #	Mom. arm	Sta. y	$\Delta$ .Area	Sta. x
67	-4	3	5.25	-4
68	-5.5	3	4.375	-5.5
84	-6.15	0	0.634	-6.15
85	-6.5	0	0.683	-6.5
86	-6.85	0	0.683	-6.85
87	-7.2	0	0.619	-7.2
88	-8.8	0	0.619	-8.8
89	-9.15	0	0.683	-9.15
90	-9.5	0	0.683	-9.5
91	-9.85	0	0.634	-9.85
93	-6.5	1.5	3.19	-6.5
94	-8	1.5	5.062	-8
95	-9.5	1.5	3.19	-9.5
96	-6.5	3	4.375	-6.5
97	-8	3	5.25	-8
98	-9.5	3	4.375	-9.5



Configuration: 2C-16-0-20/8 Jet-Induced Pressure Increments Run 232

Page 1/2

Point	1	2	3	4	5	6	7	8	9	10
h/Dc =	17.70	11.81	8.87	5.90	4.72	3.54	2.34	1.77	1.18	
Total Thrust =	52.09	51.69	51.67	51.77	51.85	51.85	51.93	52.50	52.48	
NPR Front =	2.04	2.03	2.03	2.03	2.03	2.03	2.03	2.05	2.05	
NPR Aft =	2.00	1.99	1.99	1.99	1.99	1.99	1.99	2.00	2.00	
X-loc	ACP	ACP	ACP	ACP	ACP	ACP	ACP	ACP	ACP	ACP
Y-loc	ACP	ACP	ACP	ACP	ACP	ACP	ACP	ACP	ACP	ACP
9.85	0.00	-0.000368	-0.000299	-0.000542	-0.000653	-0.000869	-0.001223	-0.001992	-0.002659	-0.006186
9.50	0.00	-0.000398	-0.000260	-0.000662	-0.001259	-0.001312	-0.002217	-0.003740	-0.006758	
9.15	0.00	-0.000601	-0.000542	-0.000777	-0.001323	-0.001789	-0.002008	-0.002582	-0.003336	-0.006762
8.80	0.00	-0.001109	-0.001566	-0.001728	-0.002406	-0.003459	-0.003595	-0.003203	-0.003618	-0.007766
8.45	0.00	-0.001152	-0.001362	-0.002215	-0.002650	-0.003178	-0.002786	-0.004760	-0.006978	-0.007086
8.10	0.00	-0.000826	-0.001532	-0.002215	-0.003154	-0.004884	-0.004884	-0.006104	-0.006978	-0.007872
7.75	0.00	-0.000504	-0.001298	-0.002023	-0.003457	-0.004431	-0.007582	-0.008151	-0.007628	
7.40	0.00	-0.000368	-0.001276	-0.001652	-0.004054	-0.005129	-0.006258	-0.008660	-0.008660	-0.008401
7.05	0.00	-0.000409	-0.000889	-0.001392	-0.003928	-0.004800	-0.006521	-0.011520	-0.013075	
6.70	0.00	-0.000115	-0.000789	-0.001331	-0.003064	-0.004800	-0.006521	-0.009345	-0.010468	-0.012655
6.35	0.00	-0.000229	-0.000437	-0.000623	-0.002346	-0.004148	-0.005929	-0.009266	-0.013183	-0.015911
6.00	0.00	-0.000339	-0.000445	-0.000301	-0.001281	-0.002482	-0.005078	-0.009266	-0.013183	-0.015911
5.65	0.00	-0.000339	-0.000445	-0.000146	-0.000944	-0.001115	-0.002564	-0.006555	-0.012752	-0.016600
5.30	0.00	-0.000220	-0.000603	-0.000885	-0.003119	-0.002492	-0.003410	-0.002150	-0.001850	-0.006936
4.95	0.00	-0.000220	-0.000603	-0.000488	-0.004154	-0.005753	-0.008578	-0.013289	-0.011739	-0.008302
4.60	0.00	-0.000330	-0.000744	-0.001960	-0.004436	-0.007001	-0.010144	-0.015902	-0.017194	-0.022147
4.25	0.00	-0.000330	-0.000884	-0.001618	-0.003999	-0.007152	-0.009743	-0.011294	-0.013841	-0.011544
3.90	0.00	-0.000110	-0.000633	-0.001547	-0.003858	-0.003676	-0.004507	-0.001580	-0.002641	-0.003295
3.55	0.00	-0.000225	-0.000392	-0.000905	-0.002029	-0.001058	-0.002108	-0.006721	-0.010744	-0.017161
3.20	0.00	-0.000225	-0.000392	-0.000377	-0.002135	-0.004233	-0.006235	-0.009728	-0.013398	-0.016488
2.85	0.00	-0.000184	-0.000585	-0.000628	-0.003260	-0.004659	-0.006821	-0.008866	-0.011632	-0.012721
2.50	0.00	-0.000349	-0.000819	-0.001914	-0.004003	-0.004900	-0.006846	-0.008245	-0.010279	-0.009661
2.15	0.00	-0.000379	-0.000884	-0.001683	-0.003321	-0.004825	-0.006951	-0.007345	-0.009486	-0.007822
1.80	0.00	-0.000708	-0.001357	-0.001573	-0.003195	-0.003987	-0.004927	-0.005916	-0.006914	-0.006665
1.45	0.00	-0.001122	-0.001346	-0.001221	-0.001492	-0.001936	-0.004126	-0.004476	-0.004392	-0.009859
1.10	0.00	-0.000977	-0.001582	-0.002241	-0.003019	-0.004175	-0.002214	-0.002265	-0.003166	-0.006382
0.75	0.00	-0.000434	-0.000568	-0.000930	-0.001196	-0.001823	-0.001830	-0.002863	-0.002863	-0.006140
0.40	0.80	-0.000402	-0.00176	-0.000452	-0.000779	-0.001038	-0.001452	-0.001450	-0.002863	-0.006140
0.05	1.50	-0.000606	-0.001225	-0.002335	-0.003469	-0.004282	-0.004790	-0.005369	-0.007155	-0.007107
0.00	1.50	-0.000556	-0.001011	-0.002035	-0.003071	-0.004071	-0.005181	-0.006104	-0.006758	-0.007960
0.00	1.50	-0.000389	-0.000588	-0.001548	-0.003486	-0.005487	-0.006225	-0.008546	-0.009572	-0.009506
0.00	1.50	-0.000085	-0.000266	-0.000900	-0.002317	-0.003923	-0.005208	-0.008546	-0.009572	-0.009506
0.00	1.50	-0.000075	-0.000633	-0.001266	-0.002310	-0.003094	-0.002018	-0.007590	-0.012209	-0.017186
0.00	1.50	-0.000145	-0.001175	-0.002040	-0.004049	-0.006189	-0.010310	-0.015449	-0.017573	-0.019397
0.00	1.50	-0.000000	-0.000758	-0.001372	-0.003506	-0.003857	-0.004397	-0.000350	-0.000742	-0.002682
0.00	1.50	-0.000000	-0.000372	-0.000422	-0.000402	-0.000025	-0.001388	-0.008026	-0.011692	-0.016497
0.00	1.50	-0.000015	-0.000241	-0.000548	-0.002512	-0.003877	-0.006716	-0.009737	-0.013372	-0.015980
0.00	1.50	-0.000159	-0.000537	-0.001457	-0.003280	-0.004740	-0.006795	-0.007816	-0.010261	-0.009239
0.00	1.50	-0.001177	-0.003170	-0.004724	-0.008550	-0.010004	-0.009348	-0.009048	-0.009641	-0.009730
0.00	1.50	-0.000299	-0.000442	-0.000538	-0.001126	-0.001129	-0.001472	-0.002235	-0.002389	-0.006238
0.00	1.50	-0.000258	-0.000687	-0.000790	-0.001553	-0.001960	-0.001790	-0.002421	-0.002937	-0.007179
0.00	3.00	-0.006280	-0.001148	-0.000619	-0.000595	-0.005969	-0.002293	-0.002986	-0.006037	-0.006977
0.00	3.00	-0.000322	-0.000576	-0.001511	-0.002893	-0.003839	-0.004582	-0.006631	-0.008176	-0.008612
0.00	3.00	-0.000085	-0.000266	-0.000900	-0.000367	-0.000923	-0.002018	-0.007590	-0.012209	-0.017186
0.00	3.00	-0.000214	-0.000523	-0.000734	-0.002270	-0.003350	-0.005519	-0.009205	-0.010761	-0.011040
0.00	3.00	-0.000244	-0.000407	-0.000683	-0.001587	-0.002644	-0.002644	-0.005190	-0.010761	-0.011040
0.00	3.00	-0.000199	-0.000161	-0.001070	-0.003541	-0.005166	-0.008368	-0.012017	-0.015711	-0.015415
0.00	3.00	-0.000224	-0.000613	-0.000553	-0.002743	-0.003094	-0.003777	-0.000215	-0.000326	-0.002132
0.00	3.00	-0.000015	-0.000090	-0.000900	-0.000723	-0.000231	-0.001713	-0.006520	-0.011028	-0.014756
0.00	3.00	-0.000055	-0.000075	-0.000145	-0.001487	-0.003019	-0.005228	-0.008281	-0.010210	-0.011152
0.00	3.00	-0.000254	-0.000713	-0.000954	-0.002703	-0.004278	-0.005148	-0.006931	-0.009357	-0.009265
0.00	3.00	-0.000299	-0.000442	-0.000538	-0.001126	-0.001129	-0.001472	-0.002235	-0.002389	-0.006238

Configuration: 2C-16-0-20/8 Jet-Induced Pressure Increments Run 232 Page 2/2

Point	2	3	4	5	6	7	8	9	10
h/Da =	17.70	11.81	8.87	5.90	4.72	3.54	2.34	1.77	1.18
Total Thrust =	52.09	51.69	51.67	51.69	51.77	51.85	51.93	52.50	52.48
NFR Front =	2.04	2.03	2.03	2.03	2.03	2.03	2.03	2.05	2.05
NFR Aft =	2.00	1.99	1.99	1.99	1.99	1.99	1.99	2.00	2.00
X-loc	ACP	ACP	ACP	ACP	ACP	ACP	ACP	ACP	ACP
-8.00	3.00	-0.000204	-0.000839	-0.001422	-0.002492	-0.003050	-0.003811	-0.004865	-0.005544
-9.50	3.00	-0.000204	-0.000839	-0.001422	-0.002492	-0.003050	-0.003811	-0.004865	-0.005544

Force and Moment Summary  
 h/Da = 17.70 8.87 5.90 4.72 3.54 2.34 1.77 1.18  
 Balance AL/T = -0.006 -0.014 -0.018 -0.025 -0.035 -0.044 -0.052 -0.067 -0.081 -0.101  
 Pressure AL/T = -0.002 -0.012 -0.019 -0.024 -0.031 -0.037 -0.044 -0.051 -0.058 -0.065  
 Balance AM/TDa = -0.001 -0.002 0.002 0.008 0.012 0.017 0.021 0.024 0.028 0.031  
 Pressure AM/TDa = 0.036 0.021 0.021 0.024 0.029 0.032 0.036 0.041 0.044 0.048

Configuration: 2C-16-0-20/8 Jet-Induced Pressure Increments Run 233

Point	1	2	3	4	5	6	7
h/De =	17.69	11.80	8.86	5.89	4.71	3.51	2.36
Total Thrust =	137.04	136.74	136.59	136.88	136.89	136.86	136.85
NPR Front =	4.02	4.01	4.01	4.02	4.02	4.02	4.01
NPR Aft =	3.99	3.98	3.97	3.98	3.98	3.98	3.97
X-loc	Y-loc	ACP	ACP	ACP	ACP	ACP	ACP
9.85	0.00	-0.000251	-0.000379	-0.000431	-0.000803	-0.001165	-0.001710
9.50	0.00	-0.000385	-0.000431	-0.000438	-0.001146	-0.001165	-0.001791
9.15	0.00	-0.000497	-0.000570	-0.000581	-0.001379	-0.001510	-0.001899
8.80	0.00	-0.000632	-0.000726	-0.000737	-0.001595	-0.001792	-0.002241
7.20	0.00	-0.001296	-0.001492	-0.001532	-0.002370	-0.002554	-0.003297
6.85	0.00	-0.001700	-0.001942	-0.001963	-0.002457	-0.002191	-0.002397
6.50	0.00	-0.002055	-0.002332	-0.002325	-0.002623	-0.002352	-0.002532
6.15	0.00	-0.002415	-0.002710	-0.002693	-0.002952	-0.002686	-0.002863
5.50	0.00	-0.002816	-0.003140	-0.003126	-0.003375	-0.003107	-0.003296
4.75	0.00	-0.003216	-0.003540	-0.003526	-0.003775	-0.003507	-0.003696
4.00	0.00	-0.003616	-0.003940	-0.003926	-0.004175	-0.003907	-0.004096
3.25	0.00	-0.004016	-0.004340	-0.004326	-0.004575	-0.004307	-0.004496
2.50	0.00	-0.004416	-0.004740	-0.004726	-0.004975	-0.004707	-0.004896
1.50	0.00	-0.004816	-0.005140	-0.005126	-0.005375	-0.005107	-0.005296
0.75	0.00	-0.005216	-0.005540	-0.005526	-0.005775	-0.005507	-0.005696
0.00	0.00	-0.005616	-0.005940	-0.005926	-0.006175	-0.005907	-0.006096
-0.75	0.00	-0.006016	-0.006340	-0.006326	-0.006575	-0.006307	-0.006496
-1.50	0.00	-0.006416	-0.006740	-0.006726	-0.006975	-0.006707	-0.006896
-2.50	0.00	-0.006816	-0.007140	-0.007126	-0.007375	-0.007107	-0.007296
-3.25	0.00	-0.007216	-0.007540	-0.007526	-0.007775	-0.007507	-0.007696
-4.00	0.00	-0.007616	-0.007940	-0.007926	-0.008175	-0.007907	-0.008096
-4.75	0.00	-0.008016	-0.008340	-0.008326	-0.008575	-0.008307	-0.008496
-5.50	0.00	-0.008416	-0.008740	-0.008726	-0.008975	-0.008707	-0.008896
-6.15	0.00	-0.008816	-0.009140	-0.009126	-0.009375	-0.009107	-0.009296
-6.85	0.00	-0.009216	-0.009540	-0.009526	-0.009775	-0.009507	-0.009696
-7.20	0.00	-0.009616	-0.009940	-0.009926	-0.010175	-0.009907	-0.010096
-7.80	0.00	-0.010016	-0.010340	-0.010326	-0.010575	-0.010307	-0.010496
-8.15	0.00	-0.010416	-0.010740	-0.010726	-0.010975	-0.010707	-0.010896
-8.85	0.00	-0.010816	-0.011140	-0.011126	-0.011375	-0.011107	-0.011296
-9.50	0.00	-0.011216	-0.011540	-0.011526	-0.011775	-0.011507	-0.011696
-9.85	0.00	-0.011616	-0.011940	-0.011926	-0.012175	-0.011907	-0.012096
9.50	1.50	-0.000288	-0.000444	-0.000470	-0.000770	-0.000833	-0.001182
8.00	1.50	-0.000399	-0.000555	-0.000581	-0.000881	-0.000944	-0.001293
6.50	1.50	-0.000426	-0.000582	-0.000608	-0.000908	-0.000971	-0.001324
5.50	1.50	-0.000453	-0.000610	-0.000636	-0.000936	-0.000999	-0.001355
4.00	1.50	-0.000480	-0.000638	-0.000664	-0.000964	-0.001027	-0.001386
2.50	1.50	-0.000507	-0.000666	-0.000692	-0.000992	-0.001055	-0.001417
1.50	1.50	-0.000534	-0.000694	-0.000720	-0.001020	-0.001083	-0.001448
0.00	1.50	-0.000561	-0.000722	-0.000748	-0.001046	-0.001109	-0.001479
-2.50	1.50	-0.000588	-0.000750	-0.000776	-0.001069	-0.001132	-0.001510
-4.00	1.50	-0.000615	-0.000778	-0.000804	-0.001092	-0.001155	-0.001541
-5.50	1.50	-0.000642	-0.000806	-0.000832	-0.001115	-0.001178	-0.001572
-7.00	1.50	-0.000669	-0.000834	-0.000860	-0.001138	-0.001201	-0.001603
-8.50	1.50	-0.000696	-0.000862	-0.000888	-0.001161	-0.001224	-0.001634
-9.50	1.50	-0.000723	-0.000890	-0.000916	-0.001184	-0.001247	-0.001665
9.50	3.00	-0.000251	-0.000379	-0.000431	-0.000803	-0.001165	-0.001710
9.15	3.00	-0.000385	-0.000431	-0.000438	-0.001146	-0.001165	-0.001791
8.80	3.00	-0.000497	-0.000570	-0.000581	-0.001379	-0.001510	-0.001899
7.20	3.00	-0.001296	-0.001492	-0.001532	-0.002370	-0.002554	-0.003297
6.85	3.00	-0.001700	-0.001942	-0.001963	-0.002457	-0.002191	-0.002397
6.50	3.00	-0.002055	-0.002332	-0.002325	-0.002623	-0.002352	-0.002532
6.15	3.00	-0.002415	-0.002710	-0.002693	-0.002952	-0.002686	-0.002863
5.50	3.00	-0.002816	-0.003140	-0.003126	-0.003375	-0.003107	-0.003296
4.75	3.00	-0.003216	-0.003540	-0.003526	-0.003775	-0.003507	-0.003696
4.00	3.00	-0.003616	-0.003940	-0.003926	-0.004175	-0.003907	-0.004096
3.25	3.00	-0.004016	-0.004340	-0.004326	-0.004575	-0.004307	-0.004496
2.50	3.00	-0.004416	-0.004740	-0.004726	-0.004975	-0.004707	-0.004896
1.50	3.00	-0.004816	-0.005140	-0.005126	-0.005375	-0.005107	-0.005296
0.75	3.00	-0.005216	-0.005540	-0.005526	-0.005775	-0.005507	-0.005696
0.00	3.00	-0.005616	-0.005940	-0.005926	-0.006175	-0.005907	-0.006096
-0.75	3.00	-0.006016	-0.006340	-0.006326	-0.006575	-0.006307	-0.006496
-1.50	3.00	-0.006416	-0.006740	-0.006726	-0.006975	-0.006707	-0.006896
-2.50	3.00	-0.006816	-0.007140	-0.007126	-0.007375	-0.007107	-0.007296
-3.25	3.00	-0.007216	-0.007540	-0.007526	-0.007775	-0.007507	-0.007696
-4.00	3.00	-0.007616	-0.007940	-0.007926	-0.008175	-0.007907	-0.008096
-4.75	3.00	-0.008016	-0.008340	-0.008326	-0.008575	-0.008307	-0.008496
-5.50	3.00	-0.008416	-0.008740	-0.008726	-0.008975	-0.008707	-0.008896
-6.15	3.00	-0.008816	-0.009140	-0.009126	-0.009375	-0.009107	-0.009296
-6.85	3.00	-0.009216	-0.009540	-0.009526	-0.009775	-0.009507	-0.009696
-7.20	3.00	-0.009616	-0.009940	-0.009926	-0.010175	-0.009907	-0.010096
-7.80	3.00	-0.010016	-0.010340	-0.010326	-0.010575	-0.010307	-0.010496
-8.15	3.00	-0.010416	-0.010740	-0.010726	-0.010975	-0.010707	-0.010896
-8.85	3.00	-0.010816	-0.011140	-0.011126	-0.011375	-0.011107	-0.011296
-9.50	3.00	-0.011216	-0.011540	-0.011526	-0.011775	-0.011507	-0.011696
-9.85	3.00	-0.011616	-0.011940	-0.011926	-0.012175	-0.011907	-0.012096
9.50	5.89	17.69	11.80	8.86	5.89	4.71	3.51
8.00	5.89	137.04	136.74	136.59	136.88	136.89	136.86
6.50	5.89	4.02	4.01	4.01	4.02	4.02	4.01
5.50	5.89	3.99	3.98	3.97	3.98	3.98	3.97
4.00	5.89	ACP	ACP	ACP	ACP	ACP	ACP
3.25	5.89	11.80	8.86	5.89	4.71	3.51	2.36
2.50	5.89	136.74	136.59	136.88	136.89	136.86	136.85
1.50	5.89	4.02	4.01	4.01	4.02	4.02	4.01
0.75	5.89	3.99	3.98	3.97	3.98	3.98	3.97
0.00	5.89	ACP	ACP	ACP	ACP	ACP	ACP
-0.75	5.89	11.80	8.86	5.89	4.71	3.51	2.36
-1.50	5.89	136.74	136.59	136.88	136.89	136.86	136.85
-2.50	5.89	4.02	4.01	4.01	4.02	4.02	4.01
-3.25	5.89	3.99	3.98	3.97	3.98	3.98	3.97
-4.00	5.89	ACP	ACP	ACP	ACP	ACP	ACP
-4.75	5.89	11.80	8.86	5.89	4.71	3.51	2.36
-5.50	5.89	136.74	136.59	136.88	136.89	136.86	136.85
-6.15	5.89	4.02	4.01	4.01	4.02	4.02	4.01
-6.85	5.89	3.99	3.98	3.97	3.98	3.98	3.97
-7.20	5.89	ACP	ACP	ACP	ACP	ACP	ACP
-7.80	5.89	11.80	8.86	5.89	4.71	3.51	2.36
-8.15	5.89	136.74	136.59	136.88	136.89	136.86	136.85
-8.85	5.89	4.02	4.01	4.01	4.02	4.02	4.01
-9.50	5.89	3.99	3.98	3.97	3.98	3.98	3.97
-9.85	5.89	ACP	ACP	ACP	ACP	ACP	ACP

Force and Moment Summary

Balance	h/De =	17.69
Pressure	AL/T =	-0.004
Balance	AL/T =	-0.012
Pressure	ΔM/TDe =	0.007
Balance	ΔM/TDe =	-0.005
Pressure	ΔM/TDe =	-0.005

Configuration: 2C-16-0-20/8 Jet-Induced Pressure Increments  
Run 234

Point	2	3	4	5	6	7
h/De =	11.81	8.84	5.89	4.72	3.53	2.35
Total Thrust =	226.33	226.36	226.28	226.24	226.17	226.19
NPR Front =	5.99	5.99	5.99	5.99	5.99	5.99
NPR Aft =	6.09	6.09	6.08	6.08	6.08	6.08
X-loc	ACP	ACP	ACP	ACP	ACP	ACP
Y-loc	ACP	ACP	ACP	ACP	ACP	ACP
9.85	0.00	-0.000250	-0.000466	-0.000735	-0.000913	-0.001089
9.50	0.00	-0.000250	-0.000466	-0.000735	-0.000913	-0.001089
9.15	0.00	-0.000704	-0.001052	-0.001850	-0.002685	-0.003329
8.80	0.00	-0.001215	-0.001408	-0.002181	-0.002555	-0.003029
7.20	0.00	-0.000888	-0.000412	-0.000021	-0.000109	-0.000307
6.80	0.00	-0.000830	-0.000665	-0.001260	-0.001753	-0.002269
6.50	0.00	-0.000771	-0.001009	-0.001997	-0.002979	-0.003841
6.15	0.00	-0.000655	-0.000970	-0.002447	-0.003448	-0.004499
5.50	0.00	-0.000235	-0.000961	-0.002326	-0.004136	-0.005795
4.75	0.00	-0.000397	-0.000563	-0.002104	-0.004382	-0.006229
4.00	0.00	-0.000075	-0.000247	-0.001895	-0.003442	-0.005377
3.25	0.00	-0.000211	-0.000079	-0.000586	-0.001804	-0.003032
2.50	0.00	-0.000143	-0.000047	-0.000241	-0.000953	-0.001804
1.50	0.00	-0.000154	-0.001118	-0.002578	-0.003067	-0.004724
0.75	0.00	-0.000605	-0.001077	-0.003354	-0.004368	-0.007922
0.00	0.00	-0.000029	-0.000730	-0.003498	-0.005410	-0.009258
-0.75	0.00	-0.000025	-0.000990	-0.002310	-0.004912	-0.007112
-1.50	0.00	-0.000138	-0.000425	-0.002634	-0.003143	-0.004080
-2.50	0.00	-0.000055	-0.000011	-0.000058	-0.000288	-0.000807
-3.25	0.00	-0.000055	-0.000011	-0.000058	-0.000288	-0.000807
-4.00	0.00	-0.000199	-0.000270	-0.001507	-0.003010	-0.004911
-4.75	0.00	-0.000267	-0.000772	-0.002572	-0.003908	-0.005597
-5.50	0.00	-0.000481	-0.000993	-0.002654	-0.003782	-0.005475
-6.15	0.00	-0.000676	-0.001119	-0.002724	-0.003832	-0.005189
-6.80	0.00	-0.000913	-0.001201	-0.002652	-0.003022	-0.003817
-7.20	0.00	-0.000913	-0.000804	-0.001137	-0.001619	-0.002387
-8.00	0.00	-0.001235	-0.001156	-0.000655	-0.000584	-0.000508
-8.80	0.00	-0.001501	-0.001414	-0.002432	-0.002714	-0.002985
-9.15	0.00	-0.000565	-0.000841	-0.001348	-0.001587	-0.001658
-9.50	0.00	-0.000530	-0.000735	-0.000995	-0.001191	-0.001435
-9.85	0.00	-0.000468	-0.000578	-0.000845	-0.000984	-0.001083
9.50	0.80	-0.003260	-0.004354	-0.009774	-0.009645	-0.008132
9.00	1.50	-0.000466	-0.001903	-0.001224	-0.001448	-0.001455
8.50	1.50	-0.000432	-0.001331	-0.002956	-0.004162	-0.004281
8.00	1.50	-0.000451	-0.000688	-0.002616	-0.004380	-0.005759
7.50	1.50	-0.000414	-0.000593	-0.002616	-0.004380	-0.005759
7.00	1.50	-0.000014	-0.000593	-0.000713	-0.000279	-0.000803
6.50	1.50	-0.000204	-0.000532	-0.001344	-0.002863	-0.004551
6.00	1.50	-0.000206	-0.000452	-0.003084	-0.004346	-0.004370
5.50	1.50	-0.000089	-0.000317	-0.000965	-0.002749	-0.001845
5.00	1.50	-0.000277	-0.000454	-0.002318	-0.003308	-0.004977
4.50	1.50	-0.000444	-0.000895	-0.002116	-0.004092	-0.005585
4.00	1.50	-0.000419	-0.002922	-0.006575	-0.006112	-0.007229
3.50	1.50	-0.000442	-0.000932	-0.006575	-0.006112	-0.007229
3.00	1.50	-0.000470	-0.000734	-0.001315	-0.001736	-0.002136
2.50	3.00	-0.000511	-0.002678	-0.002427	-0.002953	-0.004411
2.00	3.00	-0.000501	-0.001518	-0.002447	-0.002953	-0.004411
1.50	3.00	-0.000014	-0.000593	-0.000713	-0.000578	-0.000687
1.00	3.00	-0.000250	-0.000450	-0.000713	-0.000279	-0.000803
0.50	3.00	-0.000250	-0.000450	-0.001436	-0.002384	-0.004443
0.00	3.00	-0.000085	-0.000471	-0.001825	-0.002151	-0.003741
-0.50	3.00	-0.000111	-0.000907	-0.002960	-0.003909	-0.006281
-1.00	3.00	-0.000087	-0.000249	-0.000352	-0.001634	-0.003045
-1.50	3.00	-0.000206	-0.000239	-0.000135	-0.000352	-0.001314
-2.00	3.00	-0.000366	-0.000377	-0.001703	-0.002856	-0.004287
-2.50	3.00	-0.000312	-0.000873	-0.002200	-0.003370	-0.004343
-3.00	3.00	-0.000462	-0.000672	-0.000915	-0.001126	-0.001313
-3.50	3.00	-0.000462	-0.000672	-0.000915	-0.001126	-0.001313

Force and Moment Summary

Balance h/De =	11.81	8.84	5.89	4.72	3.53	2.35
Pressure Al/T =	-0.007	-0.013	-0.044	-0.052	-0.057	-0.094
Balance Al/T =	0.005	0.021	0.040	0.052	0.061	0.084
Pressure Al/TDe =	0.005	0.006	0.000	0.002	-0.010	-0.023
Balance Al/TDe =	0.002	0.004	0.019	0.005	0.010	-0.000



Pressure Orifice Locations and Weighting Factors

Conf. # 2C\_16\_0\_DW

Distance from balance center to moment reference point,  $X_o = 0$

Orif. #	Mom. arm	Sta. y	$\Delta$ .Area	Sta. x
1	18.6	0	2.3	19
2	16.86	0	6.918	17
3	15	0	3	15
4	13	0	3	13
5	11	0	3	11
6	15	1.5	8.546	15
7	13	1.5	6	13
8	11	1.5	6	11
9	12.87	3	7.166	13
10	11	3	7	11
11	10.14	5	8.91	10
12	8	5	8	8
13	6	5	8	6
14	4	5	8	4
15	2	5	8	2
16	0	5	8	0
17	-2	5	8	-2
18	-4	5	8	-4
19	-6	5	8	-6
20	-7.91	5	8.06	-8
21	7.06	6.6	7.302	7.5
22	4	7	16	4
23	0	7	16	0
24	-4	7	16	-4
25	-7.31	7	10.484	-7.6
26	3.235	8.5	9.904	0
27	0	9	12	0
28	-4	9	16	-4
29	-7.11	9	8.908	-7.2
30	0	10	8	0
31	-0.84	11	8.376	0
32	-4	11	12	-4
33	-4	12	8	-4
34	-6.86	12	12.005	-6.6
35	-4.17	13	6.883	-4
69	9.85	0	0.634	9.85
70	9.5	0	0.683	9.5
71	9.15	0	0.683	9.15
72	8.8	0	0.619	8.8
73	7.2	0	0.619	7.2
74	6.85	0	0.683	6.85
75	6.5	0	0.683	6.5
76	6.15	0	0.634	6.15
77	8	0.8	1.238	8
78	9.5	1.5	3.19	9.5
79	8	1.5	3.825	8

Conf. # 2C\_16\_0\_DW, continued

Orif. #	Mom. arm	Sta. y	Δ.Area	Sta. x
80	6.5	1.5	3.19	6.5
81	9.5	3	4.375	9.5
82	8	3	5.25	8
83	6.5	3	4.375	6.5
47	5.5	0	1.313	5.5
48	4.75	0	1.125	4.75
49	4	0	1.125	4
50	3.25	0	1.125	3.25
51	2.5	0	1.313	2.5
52	5.5	1.5	3.75	5.5
53	4	1.5	4.5	4
54	2.5	1.5	3.75	2.5
55	5.5	3	4.375	5.5
56	4	3	5.25	4
57	2.5	3	4.375	2.5
36	1.5	0	1.313	1.5
37	0.75	0	1.125	0.75
38	0	0	1.125	0
39	-0.75	0	1.125	-0.75
40	-1.5	0	1.313	-1.5
41	1.5	1.5	3.75	1.5
42	0	1.5	4.5	0
43	-1.5	1.5	3.75	-1.5
44	1.5	3	4.375	1.5
45	0	3	5.25	0
46	-1.5	3	4.375	-1.5
58	-2.5	0	1.313	-2.5
59	-3.25	0	1.125	-3.25
60	-4	0	1.125	-4
61	-4.75	0	1.125	-4.75
62	-5.5	0	1.313	-5.5
63	-2.5	1.5	3.75	-2.5
64	-4	1.5	4.5	-4
65	-5.5	1.5	3.75	-5.5
66	-2.5	3	4.375	-2.5
67	-4	3	5.25	-4
68	-5.5	3	4.375	-5.5
84	-6.15	0	0.634	-6.15
85	-6.5	0	0.683	-6.5
86	-6.85	0	0.683	-6.85
87	-7.2	0	0.619	-7.2
88	-8.8	0	0.619	-8.8
89	-9.15	0	0.683	-9.15
90	-9.5	0	0.683	-9.5
91	-9.85	0	0.634	-9.85
93	-6.5	1.5	3.19	-6.5
94	-8	1.5	5.062	-8
95	-9.5	1.5	3.19	-9.5
96	-6.5	3	4.375	-6.5
97	-8	3	5.25	-8
98	-9.5	3	4.375	-9.5





Configuration: 2C-16-0-DW Jet-Induced Pressure Increments Run 236

Point	1	2	3	4	5	6	7
h/D <sub>e</sub>	17.68	11.80	8.83	5.88	4.70	3.51	2.33
Total Thrust =	137.32	137.21	137.17	137.20	137.20	137.21	137.17
NPR Front =	4.03	4.02	4.02	4.02	4.02	4.02	4.02
NPR Aft =	3.99	3.99	3.99	3.99	3.99	3.99	3.99
X-loc	ACP	ACP	ACP	ACP	ACP	ACP	ACP
Y-loc	ACP	ACP	ACP	ACP	ACP	ACP	ACP
19.00	0.00	-0.000231	-0.000087	-0.000147	-0.000473	-0.000883	-0.000995
17.00	0.00	-0.000126	-0.000087	-0.000252	-0.000397	-0.000799	-0.001066
15.00	0.00	-0.000242	-0.000242	-0.000495	-0.000588	-0.000899	-0.001284
13.00	0.00	-0.000107	-0.000331	-0.000715	-0.000801	-0.001047	-0.001756
11.00	0.00	-0.000310	-0.000494	-0.001108	-0.001548	-0.001582	-0.003232
9.50	0.00	-0.000246	-0.000408	-0.000966	-0.001135	-0.001040	-0.003118
8.50	0.00	-0.000461	-0.000674	-0.001439	-0.002091	-0.001468	-0.002997
7.50	0.00	-0.000880	-0.001137	-0.002859	-0.002533	-0.000888	-0.002251
7.20	0.00	-0.000980	-0.000673	-0.001050	-0.000786	-0.000860	-0.005934
6.50	0.00	-0.000387	-0.001063	-0.001278	-0.002567	-0.002609	-0.004869
6.15	0.00	-0.000278	-0.000638	-0.001487	-0.003366	-0.004723	-0.005861
5.50	0.00	-0.000417	-0.000665	-0.001107	-0.003243	-0.005152	-0.008248
4.75	0.00	-0.000427	-0.000332	-0.000456	-0.002740	-0.004298	-0.007007
4.00	0.00	-0.000096	-0.000027	-0.000616	-0.001695	-0.003523	-0.012799
3.25	0.00	-0.000053	-0.000030	-0.001107	-0.000133	-0.000869	-0.012730
2.50	0.00	-0.000013	-0.000014	-0.001145	-0.000127	-0.000631	-0.010022
1.50	0.00	-0.000015	-0.000045	-0.001200	-0.003645	-0.004908	-0.000227
0.75	0.00	-0.000044	-0.000025	-0.000645	-0.001656	-0.005182	-0.007165
-0.75	0.00	-0.000083	-0.000125	-0.000854	-0.002675	-0.004821	-0.005832
-1.50	0.00	-0.000110	-0.000215	-0.000703	-0.002585	-0.003761	-0.002188
-2.50	0.00	-0.000123	-0.000245	-0.000703	-0.000621	-0.000185	-0.001522
-3.25	0.00	-0.000021	-0.000165	-0.000608	-0.000659	-0.000420	-0.011322
-4.00	0.00	-0.000051	-0.000411	-0.000608	-0.001459	-0.003030	-0.007860
-4.75	0.00	-0.000216	-0.000849	-0.001128	-0.002646	-0.004899	-0.013808
-5.50	0.00	-0.000218	-0.000849	-0.001128	-0.002646	-0.004899	-0.013808
-6.15	0.00	-0.000428	-0.000849	-0.001541	-0.003302	-0.004872	-0.017811
-6.50	0.00	-0.000579	-0.000811	-0.001946	-0.003876	-0.004835	-0.008165
-6.85	0.00	-0.000717	-0.000814	-0.001968	-0.003876	-0.004835	-0.006599
-7.20	0.00	-0.001273	-0.001336	-0.001885	-0.002642	-0.004666	-0.005242
-8.80	0.00	-0.000427	-0.001805	-0.002001	-0.002026	-0.003580	-0.005246
-9.15	0.00	-0.000306	-0.000386	-0.000808	-0.001843	-0.002407	-0.002490
-9.50	0.00	-0.000255	-0.000588	-0.000846	-0.001679	-0.001895	-0.003358
-9.85	0.00	-0.000100	-0.000329	-0.000810	-0.001218	-0.001679	-0.002331
8.00	0.80	-0.000148	-0.000390	-0.000707	-0.001178	-0.001378	-0.002331
15.00	1.50	-0.000148	-0.000447	-0.001247	-0.001168	-0.001049	-0.001444
13.00	1.50	-0.000170	-0.000380	-0.000602	-0.001139	-0.001339	-0.002225
11.00	1.50	-0.000177	-0.000491	-0.000972	-0.001214	-0.002262	-0.001839
9.50	1.50	-0.000284	-0.000562	-0.001135	-0.001243	-0.001164	-0.002305
8.00	1.50	-0.000331	-0.000899	-0.001725	-0.002378	-0.002339	-0.001318
6.50	1.50	-0.000255	-0.000588	-0.001357	-0.003648	-0.005129	-0.004335
4.00	1.50	-0.000253	-0.000216	-0.000587	-0.002244	-0.005129	-0.006875
2.50	1.50	-0.000076	-0.000267	-0.000820	-0.001348	-0.001363	-0.002865
0.00	1.50	-0.000100	-0.000428	-0.000820	-0.001348	-0.001363	-0.002865
-1.50	1.50	-0.000055	-0.000388	-0.000979	-0.002494	-0.004099	-0.001347
-2.50	1.50	-0.000236	-0.000617	-0.000801	-0.001681	-0.002708	-0.001401
-4.00	1.50	-0.000113	-0.000854	-0.001480	-0.002278	-0.005186	-0.007455
-5.50	1.50	-0.001318	-0.002532	-0.005294	-0.011637	-0.010850	-0.007455
-6.50	1.50	-0.001180	-0.002532	-0.005294	-0.011637	-0.010850	-0.007455
-8.00	1.50	-0.000180	-0.000456	-0.000801	-0.001173	-0.001660	-0.002337
13.00	3.00	-0.000139	-0.000408	-0.000698	-0.001032	-0.001512	-0.002061
11.00	3.00	-0.000148	-0.000557	-0.000912	-0.001190	-0.002435	-0.002817
9.50	3.00	-0.000244	-0.001810	-0.001513	-0.001890	-0.001042	-0.002760
8.00	3.00	-0.000255	-0.000376	-0.001253	-0.003465	-0.002045	-0.001995
6.50	3.00	-0.000023	-0.000216	-0.000587	-0.002044	-0.001333	-0.002880
5.50	3.00	-0.000140	-0.000119	-0.000062	-0.002545	-0.004664	-0.007290
4.00	3.00	-0.000140	-0.000182	-0.000062	-0.002545	-0.004664	-0.007290
2.50	3.00	-0.000112	-0.000182	-0.000164	-0.001605	-0.001919	-0.001749
0.00	3.00	-0.000064	-0.000178	-0.000266	-0.001605	-0.002876	-0.005462
-1.50	3.00	-0.000178	-0.000369	-0.000876	-0.002883	-0.002511	-0.000713
-2.50	3.00	-0.000125	-0.000335	-0.000257	-0.001349	-0.000144	-0.004702

Force and Moment Summary  
 h/D<sub>e</sub> = 17.68  
 Balance AL/T = -0.015  
 Pressure AL/T = -0.108  
 Balance AM/TDe = -0.021  
 Pressure AM/TDe = 0.002

Configuration: 2C-16-0-DM Jet-Induced Pressure Increments Run 237

Point	1	2	3	4	5	6
h/D <sub>e</sub> =	17.67	11.76	8.82	5.87	4.70	3.51
Total Thrust =	226.84	226.91	226.83	226.84	226.94	226.89
NPR Front =	6.01	6.01	6.01	6.01	6.01	6.01
NPR Alc =	6.10	6.10	6.09	6.09	6.09	6.09
X-loc	Y-loc	ACP	ACP	ACP	ACP	ACP
19.00	0.00	-0.000102	-0.000102	-0.000157	-0.000456	-0.000654
17.00	0.00	-0.000118	-0.000148	-0.000215	-0.000382	-0.000571
15.00	0.00	-0.000099	-0.000181	-0.000328	-0.000496	-0.000704
13.00	0.00	-0.000117	-0.000202	-0.000372	-0.000517	-0.000719
11.00	0.00	-0.000206	-0.000498	-0.000817	-0.001123	-0.001423
9.85	0.00	-0.000290	-0.000722	-0.001123	-0.001523	-0.001912
9.50	0.00	-0.000485	-0.001031	-0.001370	-0.001729	-0.002104
9.15	0.00	-0.000544	-0.001031	-0.001370	-0.001729	-0.002104
8.80	0.00	-0.000544	-0.001031	-0.001370	-0.001729	-0.002104
7.20	0.00	-0.000582	-0.000801	-0.001138	-0.001495	-0.001848
6.85	0.00	-0.000582	-0.000801	-0.001138	-0.001495	-0.001848
6.50	0.00	-0.000318	-0.000342	-0.001115	-0.001366	-0.001648
6.15	0.00	-0.000133	-0.000230	-0.000722	-0.000942	-0.001171
5.50	0.00	-0.000105	-0.000061	-0.001012	-0.001254	-0.001506
4.75	0.00	-0.000095	-0.000006	-0.000237	-0.000363	-0.000472
4.00	0.00	-0.000185	-0.000185	-0.000099	-0.000267	-0.000342
3.25	0.00	-0.000025	-0.000037	-0.000110	-0.000055	-0.000185
2.50	0.00	-0.000025	-0.000152	-0.000622	-0.001932	-0.002643
1.75	0.00	-0.000021	-0.000444	-0.000881	-0.002528	-0.004670
1.00	0.00	-0.000021	-0.000444	-0.000881	-0.002528	-0.004670
-0.75	0.00	-0.000038	-0.000414	-0.000681	-0.002662	-0.004142
-1.50	0.00	-0.000129	-0.000437	-0.000386	-0.001888	-0.002023
-2.50	0.00	-0.000085	-0.000379	-0.000238	-0.000421	-0.001016
-3.25	0.00	-0.000168	-0.000582	-0.000742	-0.001368	-0.002069
-4.00	0.00	-0.000185	-0.000691	-0.000932	-0.001797	-0.002718
-4.75	0.00	-0.000236	-0.000715	-0.001228	-0.003164	-0.004569
-5.50	0.00	-0.000436	-0.000774	-0.001291	-0.003236	-0.004958
-6.15	0.00	-0.000435	-0.000965	-0.001462	-0.002432	-0.003664
-6.85	0.00	-0.000749	-0.000995	-0.001179	-0.001593	-0.001928
-7.20	0.00	-0.000976	-0.001110	-0.001369	-0.000669	-0.001988
-8.00	0.00	-0.000817	-0.001380	-0.001437	-0.003433	-0.003742
-9.15	0.00	-0.000426	-0.000863	-0.001201	-0.002229	-0.002867
-9.50	0.00	-0.000318	-0.000617	-0.000765	-0.001391	-0.001888
-8.85	0.00	-0.000236	-0.000435	-0.000768	-0.001172	-0.001593
-8.00	0.00	-0.000854	-0.002843	-0.003776	-0.007951	-0.004995
15.00	1.50	-0.00161	-0.000370	-0.001010	-0.001068	-0.000966
13.00	1.50	-0.000074	-0.000417	-0.000530	-0.000980	-0.001305
11.00	1.50	-0.000173	-0.000282	-0.001043	-0.002055	-0.001105
9.50	1.50	-0.000138	-0.000468	-0.001071	-0.002055	-0.000611
8.00	1.50	-0.000378	-0.001242	-0.002392	-0.003920	-0.002872
6.50	1.50	-0.000154	-0.000425	-0.001322	-0.003703	-0.004108
5.50	1.50	-0.000049	-0.000233	-0.001240	-0.002739	-0.004771
4.00	1.50	-0.000049	-0.000233	-0.001240	-0.002739	-0.004771
2.50	1.50	-0.000026	-0.000064	-0.000315	-0.000418	-0.000471
1.50	1.50	-0.000111	-0.000075	-0.000284	-0.002497	-0.005117
0.00	1.50	-0.000111	-0.000075	-0.000284	-0.002497	-0.005117
-1.50	1.50	-0.000158	-0.000497	-0.001166	-0.002157	-0.003776
-2.50	1.50	-0.000268	-0.000657	-0.001166	-0.002157	-0.003776
-3.50	1.50	-0.000250	-0.000727	-0.001406	-0.002998	-0.004838
-4.50	1.50	-0.001133	-0.001869	-0.004333	-0.009366	-0.008692
-5.50	1.50	-0.001133	-0.001869	-0.004333	-0.009366	-0.008692
-6.50	1.50	-0.000244	-0.000619	-0.000898	-0.001315	-0.001730
-7.50	1.50	-0.000148	-0.000352	-0.000580	-0.001142	-0.001434
-8.50	1.50	-0.000109	-0.000442	-0.001126	-0.002047	-0.001047
-9.50	1.50	-0.000026	-0.000260	-0.001139	-0.002445	-0.001139
3.00	3.00	-0.000026	-0.000446	-0.001237	-0.002445	-0.003777
5.50	3.00	0.000026	-0.000464	-0.000315	-0.000418	-0.000471
8.00	3.00	0.000011	-0.000017	-0.000632	-0.002049	-0.003804
11.00	3.00	0.000011	-0.000017	-0.000632	-0.002049	-0.003804
13.00	3.00	0.000011	-0.000017	-0.000632	-0.002049	-0.003804
15.00	3.00	0.000011	-0.000017	-0.000632	-0.002049	-0.003804
17.50	3.00	-0.000057	-0.000218	-0.000522	-0.002137	-0.004158
20.00	3.00	-0.000057	-0.000218	-0.000522	-0.002137	-0.004158
22.50	3.00	-0.000237	-0.000602	-0.000093	-0.000307	-0.001766

Point	1	2	3	4	5	6
h/D <sub>e</sub> =	17.67	11.76	8.82	5.87	4.70	3.51
Total Thrust =	226.84	226.91	226.83	226.84	226.94	226.89
NPR Front =	6.01	6.01	6.01	6.01	6.01	6.01
NPR Alc =	6.10	6.10	6.09	6.09	6.09	6.09
X-loc	Y-loc	ACP	ACP	ACP	ACP	ACP
-4.00	0.00	-0.000184	-0.000592	-0.000695	-0.002446	-0.003591
-5.50	0.00	-0.000255	-0.000652	-0.001299	-0.003104	-0.004683
-6.50	0.00	-0.000244	-0.000619	-0.000898	-0.001315	-0.001730
-7.50	0.00	-0.000268	-0.000815	-0.001241	-0.002823	-0.003509
-8.50	0.00	-0.000268	-0.000815	-0.001241	-0.002823	-0.003509
-9.50	0.00	-0.000268	-0.000815	-0.001241	-0.002823	-0.003509
-10.50	0.00	-0.000268	-0.000815	-0.001241	-0.002823	-0.003509
-11.50	0.00	-0.000268	-0.000815	-0.001241	-0.002823	-0.003509
-12.50	0.00	-0.000268	-0.000815	-0.001241	-0.002823	-0.003509
-13.50	0.00	-0.000268	-0.000815	-0.001241	-0.002823	-0.003509
-14.50	0.00	-0.000268	-0.000815	-0.001241	-0.002823	-0.003509
-15.50	0.00	-0.000268	-0.000815	-0.001241	-0.002823	-0.003509
-16.50	0.00	-0.000268	-0.000815	-0.001241	-0.002823	-0.003509
-17.50	0.00	-0.000268	-0.000815	-0.001241	-0.002823	-0.003509
-18.50	0.00	-0.000268	-0.000815	-0.001241	-0.002823	-0.003509
-19.50	0.00	-0.000268	-0.000815	-0.001241	-0.002823	-0.003509
-20.50	0.00	-0.000268	-0.000815	-0.001241	-0.002823	-0.003509
-21.50	0.00	-0.000268	-0.000815	-0.001241	-0.002823	-0.003509
-22.50	0.00	-0.000268	-0.000815	-0.001241	-0.002823	-0.003509
-23.50	0.00	-0.000268	-0.000815	-0.001241	-0.002823	-0.003509
-24.50	0.00	-0.000268	-0.000815	-0.001241	-0.002823	-0.003509
-25.50	0.00	-0.000268	-0.000815	-0.001241	-0.002823	-0.003509
-26.50	0.00	-0.000268	-0.000815	-0.001241	-0.002823	-0.003509
-27.50	0.00	-0.000268	-0.000815	-0.001241	-0.002823	-0.003509
-28.50	0.00	-0.000268	-0.000815	-0.001241	-0.002823	-0.003509
-29.50	0.00	-0.000268	-0.000815	-0.001241	-0.002823	-0.003509
-30.50	0.00	-0.000268	-0.000815	-0.001241	-0.002823	-0.003509
-31.50	0.00	-0.000268	-0.000815	-0.001241	-0.002823	-0.003509
-32.50	0.00	-0.000268	-0.000815	-0.001241	-0.002823	-0.003509
-33.50	0.00	-0.000268	-0.000815	-0.001241	-0.002823	-0.003509
-34.50	0.00	-0.000268	-0.000815	-0.001241	-0.002823	-0.003509
-35.50	0.00	-0.000268	-0.000815	-0.001241	-0.002823	-0.003509
-36.50	0.00	-0.000268	-0.000815	-0.001241	-0.002823	-0.003509
-37.50	0.00	-0.000268	-0.000815	-0.001241	-0.002823	-0.003509
-38.50	0.00	-0.000268	-0.000815	-0.001241	-0.002823	-0.003509
-39.50	0.00	-0.000268	-0.000815	-0.001241	-0.002823	-0.003509
-40.50	0.00	-0.000268	-0.000815	-0.001241	-0.002823	-0.003509
-41.50	0.00	-0.000268	-0.000815	-0.001241	-0.002823	-0.003509
-42.50	0.00	-0.000268	-0.000815	-0.001241	-0.002823	-0.003509
-43.50	0.00	-0.000268	-0.000815	-0.001241	-0.002823	-0.003509
-44.50	0.00	-0.000268	-0.000815	-0.001241	-0.002823	-0.003509
-45.50	0.00	-0.000268	-0.000815	-0.001241	-0.002823	-0.003509
-46.50	0.00	-0.000268	-0.000815	-0.001241	-0.002823	-0.003509
-47.50	0.00	-0.000268	-0.000815	-0.001241	-0.002823	-0.003509
-48.50	0.00	-0.000268	-0.000815	-0.001241	-0.002823	-0.003509
-49.50	0.00	-0.000268	-0.000815	-0.001241	-0.002823	-0.003509
-50.50	0.00	-0.000268	-0.000815	-0.001241	-0.002823	-0.003509
-51.50	0.00	-0.000268	-0.000815	-0.001241	-0.002823	-0.003509
-52.50	0.00	-0.000268	-0.000815	-0.001241	-0.002823	-0.003509
-53.50	0.00	-0.000268	-0.000815	-0.001241	-0.002823	-0.003509
-54.50	0.00	-0.000268	-0.000815	-0.001241	-0.002823	-0.003509
-55.50	0.00	-0.000268	-0.000815	-0.001241	-0.002823	-0.003509
-56.50	0.00	-0.000268	-0.000815	-0.001241	-0.002823	-0.003509
-57.50	0.00	-0.000268	-0.000815	-0.001241	-0.002823	-0.003509
-58.50	0.00	-0.000268	-0.000815	-0.001241	-0.002823	-0.003509
-59.50	0.00	-0.000268	-0.000815	-0.001241	-0.002823	-0.003509
-60.50	0.00	-0.000268	-0.000815	-0.001241	-0.002823	-0.003509
-61.50	0.00	-0.000268	-0.000815	-0.001241	-0.002823	-0.003509
-62.50	0.00	-0.000268	-0.000815	-0.001241	-0.002823	-0.003509
-63.50	0.00	-0.000268	-0.000815	-0.001241	-0.002823	-0.003509
-64.50	0.00	-0.000268	-0.000815	-0.001241	-0.002823	-0.003509
-65.50	0.00	-0.000268	-0.000815	-0.001241	-0.002823	-0.003509
-66.50	0.00	-0.000268	-0.000815	-0.001241	-0.002823	-0.003509
-67.50	0.00	-0.000268	-0.000815	-0.001241	-0.002823	-0.003509
-68						

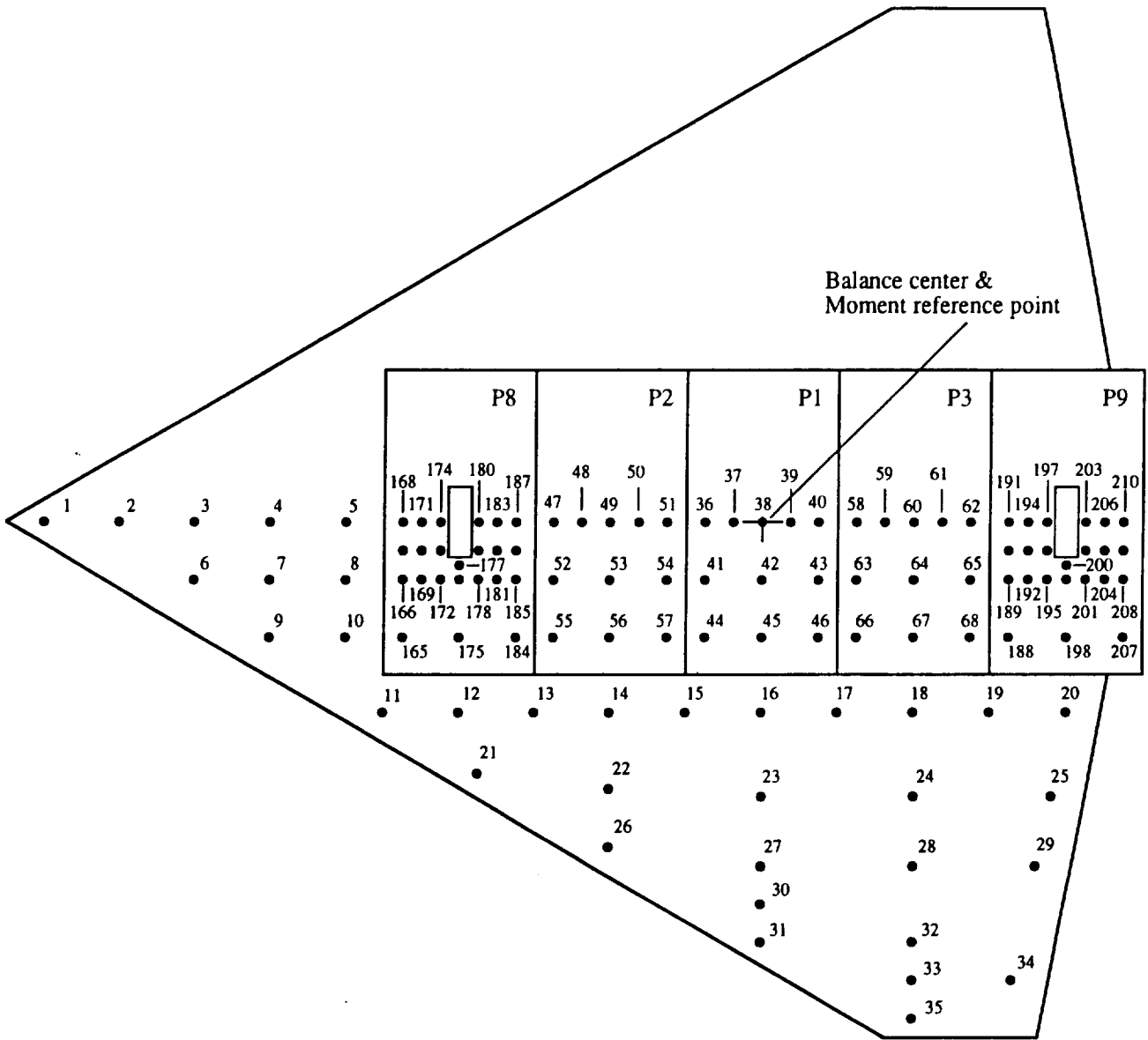

Figure 68. Configuration 2R\_16\_0\_DW;  $D_e = 1.695 \text{ in.}$ ,  $A_{jet} = 2.26 \text{ in.}^2$ .

Pressure Orifice Locations and Weighting Factors

Conf. # 2R\_16\_0\_DW

Distance from balance center to moment reference point,  $X_0 = 0$

Orif. #	Mom. arm	Sta. y	Δ.Area	Sta. x
1	18.6	0	2.3	19
2	16.86	0	6.918	17
3	15	0	3	15
4	13	0	3	13
5	11	0	3	11
6	15	1.5	8.546	15
7	13	1.5	6	13
8	11	1.5	6	11
9	12.87	3	7.166	13
10	11	3	7	11
11	10.14	5	8.91	10
12	8	5	8	8
13	6	5	8	6
14	4	5	8	4
15	2	5	8	2
16	0	5	8	0
17	-2	5	8	-2
18	-4	5	8	-4
19	-6	5	8	-6
20	-7.91	5	8.06	-8
21	7.06	6.6	7.302	7.5
22	4	7	16	4
23	0	7	16	0
24	-4	7	16	-4
25	-7.31	7	10.484	-7.6
26	3.235	8.5	9.904	0
27	0	9	12	0
28	-4	9	16	-4
29	-7.11	9	8.908	-7.2
30	0	10	8	0
31	-0.84	11	8.376	0
32	-4	11	12	-4
33	-4	12	8	-4
34	-6.86	12	12.005	-6.6
35	-4.17	13	6.883	-4
165	9.5	3	5.313	9.5
166	9.5	1.5	1.125	9.5
167	9.5	0.75	1.125	9.5
168	9.5	0	0.563	9.5
169	9	1.5	0.75	9
170	9	0.75	0.75	9
171	9	0	0.375	9
172	8.5	1.5	0.625	8.5
173	8.5	0.75	0.578	8.5
174	8.5	0	0.295	8.5
175	8	3	6.375	8

Conf. # 2R\_16\_0\_DW, continued

Orif. #	Mom. arm	Sta. y	Δ.Area	Sta. x
176	8	1.5	0.625	8
177	8	1.125	0.62	8
178	7.5	1.5	0.625	7.5
179	7.5	0.75	0.578	7.5
180	7.5	0	0.295	7.5
181	7	1.5	0.75	7
182	7	0.75	0.75	7
183	7	0	0.375	7
184	6.5	3	5.313	6.5
185	6.5	1.5	1.125	6.5
186	6.5	0.75	1.125	6.5
187	6.5	0	0.563	6.5
47	5.5	0	1.313	5.5
48	4.75	0	1.125	4.75
49	4	0	1.125	4
50	3.25	0	1.125	3.25
51	2.5	0	1.313	2.5
52	5.5	1.5	3.75	5.5
53	4	1.5	4.5	4
54	2.5	1.5	3.75	2.5
55	5.5	3	4.375	5.5
56	4	3	5.25	4
57	2.5	3	4.375	2.5
36	1.5	0	1.313	1.5
37	0.75	0	1.125	0.75
38	0	0	1.125	0
39	-0.75	0	1.125	-0.75
40	-1.5	0	1.313	-1.5
41	1.5	1.5	3.75	1.5
42	0	1.5	4.5	0
43	-1.5	1.5	3.75	-1.5
44	1.5	3	4.375	1.5
45	0	3	5.25	0
46	-1.5	3	4.375	-1.5
58	-2.5	0	1.313	-2.5
59	-3.25	0	1.125	-3.25
60	-4	0	1.125	-4
61	-4.75	0	1.125	-4.75
62	-5.5	0	1.313	-5.5
63	-2.5	1.5	3.75	-2.5
64	-4	1.5	4.5	-4
65	-5.5	1.5	3.75	-5.5
66	-2.5	3	4.375	-2.5
67	-4	3	5.25	-4
68	-5.5	3	4.375	-5.5
188	-6.5	3	5.313	-6.5
189	-6.5	1.5	1.125	-6.5
190	-6.5	0.75	1.125	-6.5
191	-6.5	0	0.563	-6.5
192	-7	1.5	0.75	-7
193	-7	0.75	0.75	-7

Conf. # 2R\_16\_0\_DW, continued

Orif. #	Mom. arm	Sta. y	$\Delta$ .Area	Sta. x
194	-7	0	0.375	-7
195	-7.5	1.5	0.625	-7.5
196	-7.5	0.75	0.578	-7.5
197	-7.5	0	0.295	-7.5
198	-8	3	6.375	-8
199	-8	1.5	0.625	-8
200	-8	1.125	0.62	-8
201	-8.5	1.5	0.625	-8.5
202	-8.5	0.75	0.578	-8.5
203	-8.5	0	0.295	-8.5
204	-9	1.5	0.75	-9
205	-9	0.75	0.75	-9
206	-9	0	0.375	-9
207	-9.5	3	5.313	-9.5
208	-9.5	1.5	1.125	-9.5
209	-9.5	0.75	1.125	-9.5
210	-9.5	0	0.563	-9.5

Configuration: 2R-16-0-DW  
 Jet-Induced Pressure Increments  
 Run 238

Point	1	2	Point	1	2		
h/De =	5.90	2.35	h/De =	5.90	2.35		
Total Thrust =	51.60	51.82	Total Thrust =	51.60	51.82		
NPR Front =	2.19	2.11	NPR Front =	2.19	2.11		
NPR Aft =	1.99	2.08	NPR Aft =	1.99	2.08		
X-loc	Y-loc	ACP	X-loc	Y-loc	ACP		
19.00	0.00	-0.000813	-0.000998	-7.50	1.50	-0.008471	-0.008252
17.00	0.00	-0.000763	-0.000879	-8.50	1.50	-0.010441	-0.007734
15.00	0.00	-0.000573	-0.001152	-8.50	1.50	-0.007964	-0.005684
13.00	0.00	-0.000942	-0.001549	-9.00	1.50	-0.004237	-0.003558
11.00	0.00	-0.001782	-0.004372	-9.50	1.50	-0.002298	-0.003166
9.00	0.00	-0.002072	-0.004848	11.00	3.00	-0.001142	-0.003271
8.50	0.00	-0.002136	-0.004703	9.50	3.00	-0.001217	-0.003203
7.50	0.00	-0.001739	-0.004283	8.00	3.00	-0.002648	-0.004415
6.50	0.00	-0.003240	-0.008864	6.50	3.00	-0.001701	-0.005468
5.50	0.00	-0.003146	-0.011831	5.50	3.00	-0.003423	-0.009003
4.75	0.00	-0.003779	-0.012806	4.00	3.00	-0.003241	-0.009915
4.00	0.00	-0.003684	-0.012257	3.00	3.00	-0.004230	-0.012849
3.25	0.00	-0.003633	-0.011221	2.50	3.00	-0.004230	-0.012849
2.50	0.00	-0.002735	-0.007855	1.50	3.00	-0.002866	-0.003073
1.50	0.00	-0.001787	-0.002839	-1.50	3.00	0.003538	0.006436
0.75	0.00	-0.000467	0.013505	-4.00	3.00	0.004401	-0.006186
0.00	0.00	0.002610	0.019260	-4.00	3.00	0.003307	-0.011596
-0.75	0.00	0.004863	0.011946	-5.50	3.00	-0.001586	-0.011091
-1.50	0.00	0.005079	-0.009889	-6.50	3.00	-0.003168	-0.010605
-2.50	0.00	0.005079	-0.009889	-8.00	3.00	-0.004514	-0.005370
-3.25	0.00	0.003372	-0.013050	-9.50	3.00	-0.001863	-0.002437
-4.00	0.00	0.002027	-0.012649	10.00	5.00	-0.001182	-0.003242
-4.75	0.00	-0.000156	-0.011317	8.00	5.00	-0.001137	-0.003411
-5.50	0.00	-0.000908	-0.008803	6.00	5.00	-0.001401	-0.004021
-6.50	0.00	0.000213	-0.006647	4.00	5.00	-0.003909	-0.010080
-7.50	0.00	0.002716	-0.003630	2.00	5.00	-0.002478	-0.006508
-8.50	0.00	-0.004157	-0.003931	0.00	5.00	0.000643	0.005888
-9.00	0.00	-0.003296	-0.003022	-2.00	5.00	0.002284	0.002715
-9.50	0.00	-0.001961	-0.003094	-4.00	5.00	-0.001471	-0.009131
9.50	0.75	-0.001654	-0.003770	-6.00	5.00	-0.002239	-0.004131
8.50	0.75	-0.001757	-0.005408	-8.00	5.00	-0.001650	-0.003708
7.50	0.75	-0.001966	-0.006291	4.00	7.00	-0.003071	-0.007114
6.50	0.75	-0.002891	-0.005438	-4.00	7.00	0.000000	0.002085
5.50	0.75	-0.002993	-0.010031	-7.60	7.00	0.000653	-0.006310
4.50	0.75	-0.001466	-0.009029	0.00	8.50	-0.001725	-0.003738
3.50	0.75	-0.002460	-0.007717	0.00	9.00	-0.000908	0.000060
2.50	0.75	-0.001730	-0.004966	-4.00	9.00	0.000414	-0.002805
1.50	0.75	-0.0020304	-0.005260	-7.20	9.00	-0.001231	-0.002512
0.50	0.75	-0.007234	-0.003710	0.00	10.00	-0.000374	-0.000372
0.00	0.75	-0.002643	-0.002988	0.00	11.00	-0.000299	-0.000323
0.00	1.13	-0.002989	-0.010335	-4.00	11.00	0.000509	-0.001564
0.00	1.13	-0.023407	-0.011363	-4.00	12.00	0.000907	0.000238
0.00	1.50	-0.001750	-0.002830	-6.60	12.00	-0.000927	-0.000998
0.00	1.50	-0.001361	-0.001891	-4.00	13.00	0.000299	-0.001008
0.00	1.50	-0.001142	-0.003669				
9.50	1.50	-0.001441	-0.005047				
9.00	1.50	-0.001944	-0.005718				
8.50	1.50	-0.001871	-0.005140				
8.00	1.50	-0.001241	-0.005832				
7.50	1.50	-0.002209	-0.007178				
7.00	1.50	-0.001411	-0.008595				
6.50	1.50	-0.004169	-0.010649				
6.00	1.50	-0.003047	-0.011944				
5.50	1.50	-0.003241	-0.009915				
5.00	1.50	-0.002309	-0.000260				
4.50	1.50	0.000823	0.013784				
4.00	1.50	0.003342	0.002129				
3.50	1.50	0.004883	-0.007801				
3.00	1.50	0.002093	-0.012388				
2.50	1.50	-0.000783	-0.011630				
2.00	1.50	-0.003546	-0.010153				
1.50	1.50	-0.004787	-0.009343				

Force and Moment Summary  
 h/De = 5.90 2.35  
 Balance AL/T = -0.102 -0.396  
 Pressure AL/T = -0.104 -0.358  
 Balance AH/TDe = -0.325 -0.360  
 Pressure AH/TDe = -0.200 -0.269

Configuration: 2R-16-0-DM Jet-Induced Pressure Increments Run 239

Point	1	2	3	4	5	6	7
h/De =	17.71	11.82	8.86	5.89	4.71	3.52	2.34
Total Thrust =	52.40	51.74	51.63	51.55	51.64	51.65	52.92
NPR Frnt =	2.13	2.11	2.11	2.10	2.10	2.10	2.14
NPR Alc =	2.10	2.09	2.08	2.08	2.09	2.09	2.11
X-loc	ACP	ACP	ACP	ACP	ACP	ACP	ACP
Y-loc	ACP	ACP	ACP	ACP	ACP	ACP	ACP
19.00	0.000265	-0.000278	-0.000170	-0.000369	-0.000713	-0.000842	-0.000870
17.00	0.000262	-0.000268	-0.000259	-0.000339	-0.000578	-0.000768	-0.000875
15.00	0.000192	-0.000403	-0.000483	-0.000664	-0.000633	-0.000797	-0.001104
13.00	0.000317	-0.000557	-0.000638	-0.000599	-0.000488	-0.000325	-0.000190
11.00	0.000491	-0.000710	-0.000729	-0.000527	-0.000287	-0.000149	-0.000088
9.50	0.000421	-0.000710	-0.000729	-0.000527	-0.000287	-0.000149	-0.000088
8.00	0.000188	-0.002219	-0.003944	-0.005179	-0.006184	-0.006937	-0.007425
7.50	0.000129	-0.000361	-0.000620	-0.000911	-0.001217	-0.001536	-0.001859
7.00	0.000085	-0.000280	-0.000466	-0.000659	-0.000856	-0.001056	-0.001259
6.50	0.000054	-0.000219	-0.000384	-0.000556	-0.000736	-0.000921	-0.001110
6.00	0.000027	-0.000166	-0.000271	-0.000398	-0.000536	-0.000676	-0.000817
5.50	0.000000	-0.000099	-0.000166	-0.000256	-0.000356	-0.000456	-0.000556
5.00	0.000000	-0.000000	-0.000000	-0.000000	-0.000000	-0.000000	-0.000000
4.75	0.000000	-0.000000	-0.000000	-0.000000	-0.000000	-0.000000	-0.000000
4.50	0.000000	-0.000000	-0.000000	-0.000000	-0.000000	-0.000000	-0.000000
4.25	0.000000	-0.000000	-0.000000	-0.000000	-0.000000	-0.000000	-0.000000
4.00	0.000000	-0.000000	-0.000000	-0.000000	-0.000000	-0.000000	-0.000000
3.75	0.000000	-0.000000	-0.000000	-0.000000	-0.000000	-0.000000	-0.000000
3.50	0.000000	-0.000000	-0.000000	-0.000000	-0.000000	-0.000000	-0.000000
3.25	0.000000	-0.000000	-0.000000	-0.000000	-0.000000	-0.000000	-0.000000
3.00	0.000000	-0.000000	-0.000000	-0.000000	-0.000000	-0.000000	-0.000000
2.75	0.000000	-0.000000	-0.000000	-0.000000	-0.000000	-0.000000	-0.000000
2.50	0.000000	-0.000000	-0.000000	-0.000000	-0.000000	-0.000000	-0.000000
2.25	0.000000	-0.000000	-0.000000	-0.000000	-0.000000	-0.000000	-0.000000
2.00	0.000000	-0.000000	-0.000000	-0.000000	-0.000000	-0.000000	-0.000000
1.75	0.000000	-0.000000	-0.000000	-0.000000	-0.000000	-0.000000	-0.000000
1.50	0.000000	-0.000000	-0.000000	-0.000000	-0.000000	-0.000000	-0.000000
1.25	0.000000	-0.000000	-0.000000	-0.000000	-0.000000	-0.000000	-0.000000
1.00	0.000000	-0.000000	-0.000000	-0.000000	-0.000000	-0.000000	-0.000000
0.75	0.000000	-0.000000	-0.000000	-0.000000	-0.000000	-0.000000	-0.000000
0.50	0.000000	-0.000000	-0.000000	-0.000000	-0.000000	-0.000000	-0.000000
0.25	0.000000	-0.000000	-0.000000	-0.000000	-0.000000	-0.000000	-0.000000
0.00	0.000000	-0.000000	-0.000000	-0.000000	-0.000000	-0.000000	-0.000000

Force and Moment Summary  
 h/De = 17.71  
 Balance AL/T = -0.035  
 Pressure AL/T = -0.036  
 Balance AN/TDe = -0.011  
 Pressure AN/TDe = 0.013



3rd-Induced Pressure Increments  
Run 240

Point	1	2	3	4	5	6	7	8	9	10	11	12	13	14	15	16	17	18	19	20	21	22	23	24	25	26	27	28	29	30	31	32	33	34	35	36	37	38	39	40	41	42	43	44	45	46	47	48	49	50	51	52	53	54	55	56	57	58	59	60	61	62	63	64	65	66	67	68	69	70	71	72	73	74	75	76	77	78	79	80	81	82	83	84	85	86	87	88	89	90	91	92	93	94	95	96	97	98	99	100																																																																																																																																																																																																																																																																																																																																																																																																																																																																																																																																																																																																																																																																																																																																																																																																																																																																																																																																														
Total Thrust =	17.72	135.88	135.79	135.77	135.75	135.71	135.66	135.58	135.48	135.37	135.26	135.16	135.06	134.96	134.86	134.76	134.66	134.56	134.46	134.36	134.26	134.16	134.06	133.96	133.86	133.76	133.66	133.56	133.46	133.36	133.26	133.16	133.06	132.96	132.86	132.76	132.66	132.56	132.46	132.36	132.26	132.16	132.06	131.96	131.86	131.76	131.66	131.56	131.46	131.36	131.26	131.16	131.06	130.96	130.86	130.76	130.66	130.56	130.46	130.36	130.26	130.16	130.06	129.96	129.86	129.76	129.66	129.56	129.46	129.36	129.26	129.16	129.06	128.96	128.86	128.76	128.66	128.56	128.46	128.36	128.26	128.16	128.06	127.96	127.86	127.76	127.66	127.56	127.46	127.36	127.26	127.16	127.06	126.96	126.86	126.76	126.66	126.56	126.46	126.36	126.26	126.16	126.06	125.96	125.86	125.76	125.66	125.56	125.46	125.36	125.26	125.16	125.06	124.96	124.86	124.76	124.66	124.56	124.46	124.36	124.26	124.16	124.06	123.96	123.86	123.76	123.66	123.56	123.46	123.36	123.26	123.16	123.06	122.96	122.86	122.76	122.66	122.56	122.46	122.36	122.26	122.16	122.06	121.96	121.86	121.76	121.66	121.56	121.46	121.36	121.26	121.16	121.06	120.96	120.86	120.76	120.66	120.56	120.46	120.36	120.26	120.16	120.06	119.96	119.86	119.76	119.66	119.56	119.46	119.36	119.26	119.16	119.06	118.96	118.86	118.76	118.66	118.56	118.46	118.36	118.26	118.16	118.06	117.96	117.86	117.76	117.66	117.56	117.46	117.36	117.26	117.16	117.06	116.96	116.86	116.76	116.66	116.56	116.46	116.36	116.26	116.16	116.06	115.96	115.86	115.76	115.66	115.56	115.46	115.36	115.26	115.16	115.06	114.96	114.86	114.76	114.66	114.56	114.46	114.36	114.26	114.16	114.06	113.96	113.86	113.76	113.66	113.56	113.46	113.36	113.26	113.16	113.06	112.96	112.86	112.76	112.66	112.56	112.46	112.36	112.26	112.16	112.06	111.96	111.86	111.76	111.66	111.56	111.46	111.36	111.26	111.16	111.06	110.96	110.86	110.76	110.66	110.56	110.46	110.36	110.26	110.16	110.06	109.96	109.86	109.76	109.66	109.56	109.46	109.36	109.26	109.16	109.06	108.96	108.86	108.76	108.66	108.56	108.46	108.36	108.26	108.16	108.06	107.96	107.86	107.76	107.66	107.56	107.46	107.36	107.26	107.16	107.06	106.96	106.86	106.76	106.66	106.56	106.46	106.36	106.26	106.16	106.06	105.96	105.86	105.76	105.66	105.56	105.46	105.36	105.26	105.16	105.06	104.96	104.86	104.76	104.66	104.56	104.46	104.36	104.26	104.16	104.06	103.96	103.86	103.76	103.66	103.56	103.46	103.36	103.26	103.16	103.06	102.96	102.86	102.76	102.66	102.56	102.46	102.36	102.26	102.16	102.06	101.96	101.86	101.76	101.66	101.56	101.46	101.36	101.26	101.16	101.06	100.96	100.86	100.76	100.66	100.56	100.46	100.36	100.26	100.16	100.06	99.96	99.86	99.76	99.66	99.56	99.46	99.36	99.26	99.16	99.06	98.96	98.86	98.76	98.66	98.56	98.46	98.36	98.26	98.16	98.06	97.96	97.86	97.76	97.66	97.56	97.46	97.36	97.26	97.16	97.06	96.96	96.86	96.76	96.66	96.56	96.46	96.36	96.26	96.16	96.06	95.96	95.86	95.76	95.66	95.56	95.46	95.36	95.26	95.16	95.06	94.96	94.86	94.76	94.66	94.56	94.46	94.36	94.26	94.16	94.06	93.96	93.86	93.76	93.66	93.56	93.46	93.36	93.26	93.16	93.06	92.96	92.86	92.76	92.66	92.56	92.46	92.36	92.26	92.16	92.06	91.96	91.86	91.76	91.66	91.56	91.46	91.36	91.26	91.16	91.06	90.96	90.86	90.76	90.66	90.56	90.46	90.36	90.26	90.16	90.06	89.96	89.86	89.76	89.66	89.56	89.46	89.36	89.26	89.16	89.06	88.96	88.86	88.76	88.66	88.56	88.46	88.36	88.26	88.16	88.06	87.96	87.86	87.76	87.66	87.56	87.46	87.36	87.26	87.16	87.06	86.96	86.86	86.76	86.66	86.56	86.46	86.36	86.26	86.16	86.06	85.96	85.86	85.76	85.66	85.56	85.46	85.36	85.26	85.16	85.06	84.96	84.86	84.76	84.66	84.56	84.46	84.36	84.26	84.16	84.06	83.96	83.86	83.76	83.66	83.56	83.46	83.36	83.26	83.16	83.06	82.96	82.86	82.76	82.66	82.56	82.46	82.36	82.26	82.16	82.06	81.96	81.86	81.76	81.66	81.56	81.46	81.36	81.26	81.16	81.06	80.96	80.86	80.76	80.66	80.56	80.46	80.36	80.26	80.16	80.06	79.96	79.86	79.76	79.66	79.56	79.46	79.36	79.26	79.16	79.06	78.96	78.86	78.76	78.66	78.56	78.46	78.36	78.26	78.16	78.06	77.96	77.86	77.76	77.66	77.56	77.46	77.36	77.26	77.16	77.06	76.96	76.86	76.76	76.66	76.56	76.46	76.36	76.26	76.16	76.06	75.96	75.86	75.76	75.66	75.56	75.46	75.36	75.26	75.16	75.06	74.96	74.86	74.76	74.66	74.56	74.46	74.36	74.26	74.16	74.06	73.96	73.86	73.76	73.66	73.56	73.46	73.36	73.26	73.16	73.06	72.96	72.86	72.76	72.66	72.56	72.46	72.36	72.26	72.16	72.06	71.96	71.86	71.76	71.66	71.56	71.46	71.36	71.26	71.16	71.06	70.96	70.86	70.76	70.66	70.56	70.46	70.36	70.26	70.16	70.06	69.96	69.86	69.76	69.66	69.56	69.46	69.36	69.26	69.16	69.06	68.96	68.86	68.76	68.66	68.56	68.46	68.36	68.26	68.16	68.06	67.96	67.86	67.76	67.66	67.56	67.46	67.36	67.26	67.16	67.06	66.96	66.86	66.76	66.66	66.56	66.46	66.36	66.26	66.16	66.06	65.96	65.86	65.76	65.66	65.56	65.46	65.36	65.26	65.16	65.06	64.96	64.86	64.76	64.66	64.56	64.46	64.36	64.26	64.16	64.06	63.96	63.86	63.76	63.66	63.56	63.46	63.36	63.26	63.16	63.06	62.96	62.86	62.76	62.66	62.56	62.46	62.36	62.26	62.16	62.06	61.96	61.86	61.76	61.66	61.56	61.46	61.36	61.26	61.16	61.06	60.96	60.86	60.76	60.66	60.56	60.46	60.36	60.26	60.16	60.06	59.96	59.86	59.76	59.66	59.56	59.46	59.36	59.26	59.16	59.06	58.96	58.86	58.76	58.66	58.56	58.46	58.36	58.26	58.16	58.06	57.96	57.86	57.76	57.66	57.56	57.46	57.36	57.26	57.16	57.06	56.96	56.86	56.76	56.66	56.56	56.46	56.36	56.26	56.16	56.06	55.96	55.86	55.76	55.66	55.56	55.46	55.36	55.26	55.16	55.06	54.96	54.86	54.76	54.66	54.56	54.46	54.36	54.26	54.16	54.06	53.96	53.86	53.76	53.66	53.56	53.46	53.36	53.26	53.16	53.06	52.96	52.86	52.76	52.66	52.56	52.46	52.36	52.26	52.16	52.06	51.96	51.86	51.76	51.66	51.56	51.46	51.36	51.26	51.16	51.06	50.96	50.86	50.76	50.66	50.56	50.46	50.36	50.26	50.16	50.06	49.96	49.86	49.76	49.66	49.56	49.46	49.36	49.26	49.16	49.06	48.96	48.86	48.76	48.66	48.56	48.46	48.36	48.26	48.16	48.06	47.96	47.86	47.76	47.66	47.56	47.46	47.36	47.26	47.16	47.06	46.96	46.86	46.76	46.66	46.56	46.46	46.36	46.26	46.16	46.06	45.96	45.86	45.76	45.66	45.56	45.46	45.36	45.26	45.16	45.06	44.96	44.86	44.76	44.66	44.56	44.46	44.36	44.26	44.16	44.06	43.96	43.86	43.76	43.66	43.56	43.46	43.36	43.26	43.16	43.06	42.96	42.86	42.76	42.66	42.56	42.46	42.36	42.26	42.16	42.06	41.96	41.86	41.76	41.66	41.56	41.46	41.36	41.26	41.16	41.06	40.96	40.86	40.76	40.66	40.56	40.46	40.36	40.26	40.16	40.06	39.96	39.86	39.76	39.66	39.56	39.46	39.36	39.26	39.16	39.06	38.96	38.86	38.76	38.66	38.56	38.46	38.36	38.26	38.16	38.06	37.96	37.86	37.76	37.66	37.56	37.46	37.36	37.26	37.16	37.06	36.96	36.86	36.76	36.66	36.56	36.46	36.36	36.26	36.16	36.06	35.96	35.86	35.76	35.66	35.56	35.46	35.36</

Configuration: 2R-16-0-DM Jet-Induced Pressure Increments Run 242

Point	1	2	3	4	5	6
h/De =	17.68	11.79	8.87	5.89	4.73	3.55
Total Thrust =	220.39	219.75	220.43	220.53	220.49	220.74
NPR	6.20	6.18	6.17	6.16	6.16	6.17
Alt =	6.11	6.10	6.14	6.14	6.14	6.14
X-loc	ACP	ACP	ACP	ACP	ACP	ACP
Y-loc	ACP	ACP	ACP	ACP	ACP	ACP
19.00	0.00	-0.000054	0.000314	-0.000314	-0.000450	-0.000932
17.00	0.00	-0.000048	-0.000246	-0.000246	-0.000257	-0.000644
15.00	0.00	-0.000044	-0.000392	-0.000392	-0.000517	-0.000987
13.00	0.00	-0.000066	-0.000375	-0.000827	-0.001111	-0.000762
11.00	0.00	-0.000066	-0.000375	-0.000827	-0.001111	-0.000762
9.50	0.00	-0.000594	-0.001484	-0.002622	-0.003432	-0.003172
9.00	0.00	-0.000590	-0.000737	-0.001487	-0.002275	-0.001952
8.50	0.00	-0.000595	-0.001075	-0.002033	-0.002775	-0.001913
7.50	0.00	-0.000595	-0.001016	-0.001120	-0.002016	-0.001347
7.00	0.00	-0.000510	-0.000494	-0.000108	-0.000466	-0.000889
6.50	0.00	-0.000475	-0.000572	-0.000750	-0.001655	-0.004370
5.50	0.00	-0.000290	-0.000247	-0.000551	-0.002574	-0.004821
4.75	0.00	-0.000213	-0.000221	-0.000309	-0.002380	-0.004735
4.00	0.00	-0.000222	-0.000079	-0.000935	-0.001141	-0.001661
3.25	0.00	-0.000167	-0.000034	-0.000935	-0.001141	-0.001661
2.50	0.00	-0.000109	-0.000478	-0.001330	-0.002140	-0.003132
1.50	0.00	-0.000099	-0.000495	-0.001162	-0.003255	-0.004432
0.75	0.00	-0.000121	-0.000501	-0.001551	-0.003819	-0.005278
0.00	0.00	-0.000089	-0.000224	-0.000900	-0.002162	-0.004281
-0.75	0.00	-0.000102	-0.000130	-0.000082	-0.000713	-0.001678
-1.50	0.00	-0.000075	-0.000371	-0.000159	-0.000903	-0.001985
-2.50	0.00	-0.000362	-0.000830	-0.001195	-0.002707	-0.004428
-4.00	0.00	-0.000189	-0.000790	-0.001427	-0.003349	-0.005349
-5.50	0.00	-0.000292	-0.000911	-0.001784	-0.002425	-0.003790
-7.50	0.00	-0.000670	-0.000978	-0.001206	-0.002239	-0.002954
-8.50	0.00	-0.000535	-0.000489	-0.000078	-0.000178	-0.000718
-9.50	0.00	-0.000495	-0.000836	-0.001173	-0.002281	-0.002656
9.50	0.75	-0.000494	-0.000660	-0.001436	-0.002617	-0.003129
9.00	0.75	-0.000588	-0.000939	-0.001533	-0.005609	-0.004684
8.50	0.75	-0.000663	-0.000743	-0.000829	-0.000879	-0.000879
7.50	0.75	-0.000643	-0.000887	-0.001440	-0.001496	-0.001572
6.50	0.75	-0.000616	-0.000854	-0.001120	-0.002472	-0.003747
7.00	0.75	-0.000465	-0.001166	-0.001711	-0.003055	-0.003919
7.50	0.75	-0.000714	-0.001583	-0.002136	-0.003010	-0.004300
8.50	0.75	-0.001027	-0.000857	-0.001123	-0.001863	-0.002732
9.50	0.75	-0.000451	-0.000598	-0.000841	-0.001488	-0.002268
8.00	1.13	-0.000889	-0.000643	-0.010085	-0.012967	-0.006634
8.00	1.13	-0.001721	-0.002310	-0.007951	-0.010604	-0.007353
15.00	1.50	-0.000002	-0.000530	-0.001331	-0.001058	-0.001325
13.00	1.50	-0.000047	-0.000463	-0.000867	-0.001181	-0.001062
11.00	1.50	-0.000111	-0.000553	-0.001127	-0.001329	-0.001133
9.50	1.50	-0.000394	-0.000839	-0.001262	-0.002337	-0.001307
9.00	1.50	-0.000359	-0.001306	-0.002164	-0.002861	-0.001888
8.50	1.50	-0.000663	-0.001900	-0.002860	-0.004454	-0.003002
8.00	1.50	-0.000515	-0.003215	-0.005408	-0.008657	-0.004365
7.50	1.50	-0.000892	-0.003137	-0.003216	-0.006239	-0.005814
7.00	1.50	-0.000428	-0.001359	-0.002203	-0.003968	-0.005036
6.50	1.50	-0.000450	-0.000820	-0.001598	-0.003428	-0.004985
5.50	1.50	-0.000211	-0.000489	-0.000854	-0.002740	-0.005390
4.00	1.50	-0.000129	-0.000188	-0.000828	-0.000854	-0.000984
2.50	1.50	-0.000142	-0.000281	-0.001122	-0.003222	-0.004086
0.00	1.50	-0.000142	-0.000105	-0.000513	-0.002801	-0.003389
-1.50	1.50	-0.000121	-0.000394	-0.000330	-0.000642	-0.003393
-2.50	1.50	-0.000169	-0.000908	-0.000371	-0.001663	-0.003176
-5.00	1.50	-0.000243	-0.000685	-0.001302	-0.002965	-0.004798
-5.50	1.50	-0.000424	-0.000996	-0.001860	-0.003315	-0.005087
-6.50	1.50	-0.000631	-0.001208	-0.001934	-0.003659	-0.005188
-7.00	1.50	-0.000691	-0.001496	-0.002279	-0.003741	-0.004641

Force and Moment Summary

Point	1	2	3	4	5	6
h/De =	17.68	11.79	8.87	5.89	4.73	3.55
Balance	AL/T =	-0.024	-0.040	-0.055	-0.127	-0.184
Pressure	AM/T =	-0.018	-0.042	-0.063	-0.115	-0.178
Balance	AM/TDe =	-0.018	-0.006	-0.017	-0.011	0.008
Pressure	AM/TDe =	0.007	-0.010	-0.023	-0.006	0.010
19.00	-0.000928	-0.001428	-0.002893	-0.004659	-0.005044	-0.005643
17.00	-0.000928	-0.001428	-0.002893	-0.004659	-0.005044	-0.005643
15.00	-0.000928	-0.001428	-0.002893	-0.004659	-0.005044	-0.005643
13.00	-0.000928	-0.001428	-0.002893	-0.004659	-0.005044	-0.005643
11.00	-0.000928	-0.001428	-0.002893	-0.004659	-0.005044	-0.005643
9.50	-0.000928	-0.001428	-0.002893	-0.004659	-0.005044	-0.005643
9.00	-0.000928	-0.001428	-0.002893	-0.004659	-0.005044	-0.005643
8.50	-0.000928	-0.001428	-0.002893	-0.004659	-0.005044	-0.005643
7.50	-0.000928	-0.001428	-0.002893	-0.004659	-0.005044	-0.005643
7.00	-0.000928	-0.001428	-0.002893	-0.004659	-0.005044	-0.005643
6.50	-0.000928	-0.001428	-0.002893	-0.004659	-0.005044	-0.005643
5.50	-0.000928	-0.001428	-0.002893	-0.004659	-0.005044	-0.005643
4.75	-0.000928	-0.001428	-0.002893	-0.004659	-0.005044	-0.005643
4.00	-0.000928	-0.001428	-0.002893	-0.004659	-0.005044	-0.005643
3.25	-0.000928	-0.001428	-0.002893	-0.004659	-0.005044	-0.005643
2.50	-0.000928	-0.001428	-0.002893	-0.004659	-0.005044	-0.005643
1.50	-0.000928	-0.001428	-0.002893	-0.004659	-0.005044	-0.005643
0.75	-0.000928	-0.001428	-0.002893	-0.004659	-0.005044	-0.005643
0.00	-0.000928	-0.001428	-0.002893	-0.004659	-0.005044	-0.005643
-0.75	-0.000928	-0.001428	-0.002893	-0.004659	-0.005044	-0.005643
-1.50	-0.000928	-0.001428	-0.002893	-0.004659	-0.005044	-0.005643
-2.50	-0.000928	-0.001428	-0.002893	-0.004659	-0.005044	-0.005643
-4.00	-0.000928	-0.001428	-0.002893	-0.004659	-0.005044	-0.005643
-5.50	-0.000928	-0.001428	-0.002893	-0.004659	-0.005044	-0.005643
-7.50	-0.000928	-0.001428	-0.002893	-0.004659	-0.005044	-0.005643
-8.50	-0.000928	-0.001428	-0.002893	-0.004659	-0.005044	-0.005643
-9.50	-0.000928	-0.001428	-0.002893	-0.004659	-0.005044	-0.005643



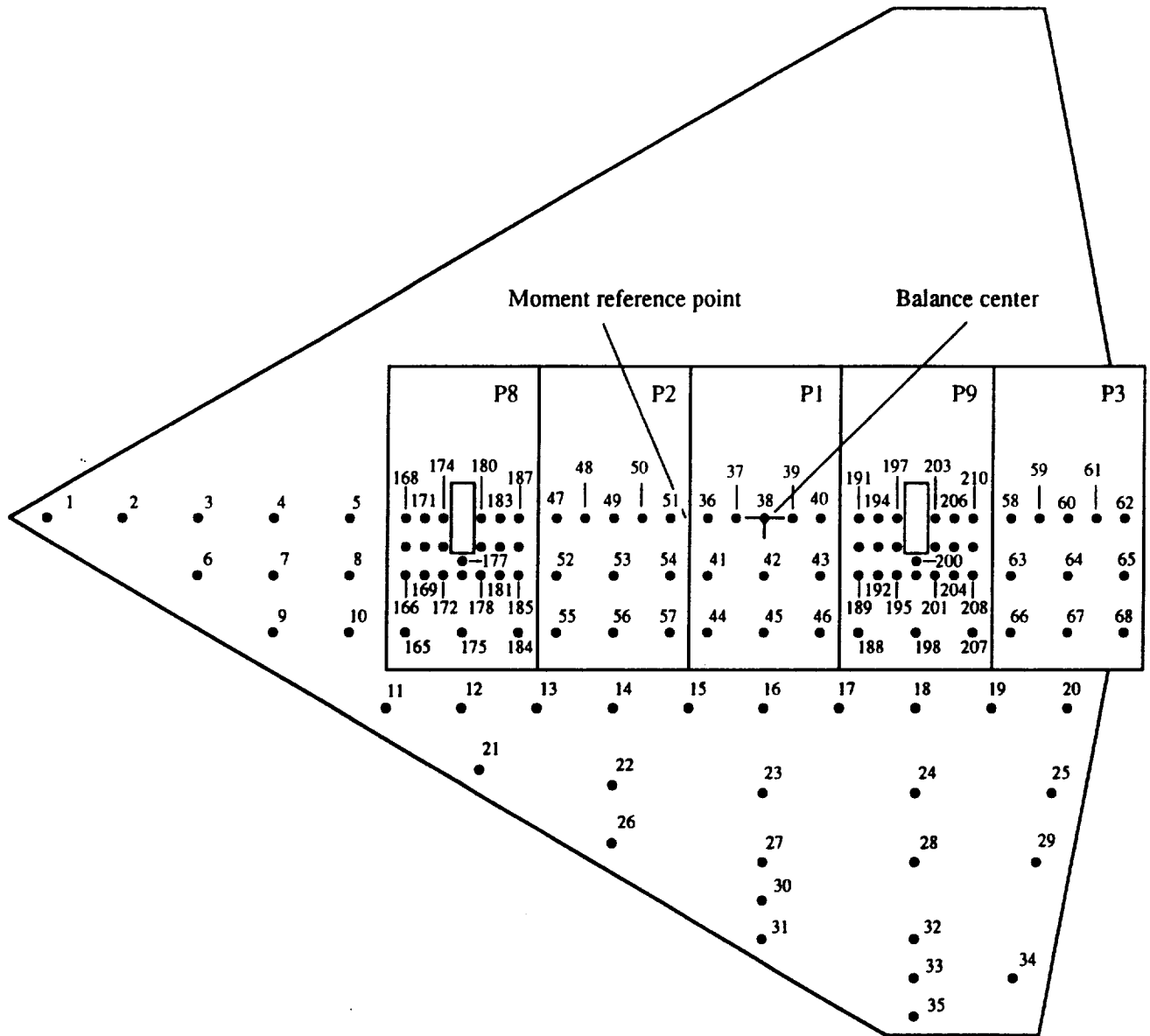

Figure 69. Configuration 2R\_12\_0\_DW;  $D_e = 1.695 \text{ in.}$ ,  $A_{jet} = 2.26 \text{ in.}^2$ .

Pressure Orifice Locations and Weighting Factors

Conf. # 2R\_12\_0\_DW

Distance from balance center to moment reference point,  $X_0 = 2$

Orif. #	Mom. arm	Sta. y	Δ.Area	Sta. x
1	16.6	0	2.3	17
2	14.86	0	6.918	15
3	13	0	3	13
4	11	0	3	11
5	9	0	3	9
6	13	1.5	8.546	13
7	11	1.5	6	11
8	9	1.5	6	9
9	10.87	3	7.166	11
10	9	3	7	9
11	8.14	5	8.91	8
12	6	5	8	6
13	4	5	8	4
14	2	5	8	2
15	0	5	8	0
16	-2	5	8	-2
17	-4	5	8	-4
18	-6	5	8	-6
19	-8	5	8	-8
20	-9.91	5	8.06	-10
21	5.06	6.6	7.302	5.5
22	2	7	16	2
23	-2	7	16	-2
24	-6	7	16	-6
25	-9.31	7	10.484	-9.6
26	1.235	8.5	9.904	-2
27	-2	9	12	-2
28	-6	9	16	-6
29	-9.11	9	8.908	-9.2
30	-2	10	8	-2
31	-2.84	11	8.376	-2
32	-6	11	12	-6
33	-6	12	8	-6
34	-8.86	12	12.005	-8.6
35	-6.17	13	6.883	-6
165	7.5	3	5.313	7.5
166	7.5	1.5	1.125	7.5
167	7.5	0.75	1.125	7.5
168	7.5	0	0.563	7.5
169	7	1.5	0.75	7
170	7	0.75	0.75	7
171	7	0	0.375	7
172	6.5	1.5	0.625	6.5
173	6.5	0.75	0.578	6.5
174	6.5	0	0.295	6.5
175	6	3	6.375	6

Conf. # 2R\_12\_0\_DW, continued

Orif. #	Mom. arm	Sta. y	Δ.Area	Sta. x
176	6	1.5	0.625	6
177	6	1.125	0.62	6
178	5.5	1.5	0.625	5.5
179	5.5	0.75	0.578	5.5
180	5.5	0	0.295	5.5
181	5	1.5	0.75	5
182	5	0.75	0.75	5
183	5	0	0.375	5
184	4.5	3	5.313	4.5
185	4.5	1.5	1.125	4.5
186	4.5	0.75	1.125	4.5
187	4.5	0	0.563	4.5
47	3.5	0	1.313	3.5
48	2.75	0	1.125	2.75
49	2	0	1.125	2
50	1.25	0	1.125	1.25
51	0.5	0	1.313	0.5
52	3.5	1.5	3.75	3.5
53	2	1.5	4.5	2
54	0.5	1.5	3.75	0.5
55	3.5	3	4.375	3.5
56	2	3	5.25	2
57	0.5	3	4.375	0.5
36	-0.5	0	1.313	-0.5
37	-1.25	0	1.125	-1.25
38	-2	0	1.125	-2
39	-2.75	0	1.125	-2.75
40	-3.5	0	1.313	-3.5
41	-0.5	1.5	3.75	-0.5
42	-2	1.5	4.5	-2
43	-3.5	1.5	3.75	-3.5
44	-0.5	3	4.375	-0.5
45	-2	3	5.25	-2
46	-3.5	3	4.375	-3.5
188	-4.5	3	5.313	-4.5
189	-4.5	1.5	1.125	-4.5
190	-4.5	0.75	1.125	-4.5
191	-4.5	0	0.563	-4.5
192	-5	1.5	0.75	-5
193	-5	0.75	0.75	-5
194	-5	0	0.375	-5
195	-5.5	1.5	0.625	-5.5
196	-5.5	0.75	0.578	-5.5
197	-5.5	0	0.295	-5.5
198	-6	3	6.375	-6
199	-6	1.5	0.625	-6
200	-6	1.125	0.62	-6
201	-6.5	1.5	0.625	-6.5
202	-6.5	0.75	0.578	-6.5
203	-6.5	0	0.295	-6.5
204	-7	1.5	0.75	-7

Conf. # 2R\_12\_0\_DW, continued

Orif. #	Mom. arm	Sta. y	Δ.Area	Sta. x
205	-7	0.75	0.75	-7
206	-7	0	0.375	-7
207	-7.5	3	5.313	-7.5
208	-7.5	1.5	1.125	-7.5
209	-7.5	0.75	1.125	-7.5
210	-7.5	0	0.563	-7.5
58	-8.5	0	1.313	-8.5
59	-9.25	0	1.125	-9.25
60	-10	0	1.125	-10
61	-10.75	0	1.125	-10.75
62	-11.5	0	1.313	-11.5
63	-8.5	1.5	3.75	-8.5
64	-10	1.5	4.5	-10
65	-11.5	1.5	3.75	-11.5
66	-8.5	3	4.375	-8.5
67	-10	3	5.25	-10
68	-11.5	3	4.375	-11.5

Configuration: 2R-12-0-DM  
 Jet-Induced Pressure Increments  
 Run 244

Point	1	2	3	4	5	6	7
h/D <sub>e</sub>	17.72	11.84	8.87	5.91	3.53	2.35	2.35
Total Thrust	51.79	52.29	52.31	52.14	54.32	52.81	52.81
NPR Front	2.11	2.10	2.10	2.10	2.21	2.12	2.12
NPR Alt	2.08	2.11	2.12	2.11	2.11	2.12	2.12
X-loc	ACP	ACP	ACP	ACP	ACP	ACP	ACP
17.00	0.00	-0.000303	-0.000394	-0.000804	-0.001255	-0.000950	-0.000916
15.00	0.00	-0.000273	-0.000364	-0.000701	-0.001288	-0.000916	-0.000916
13.00	0.00	-0.000318	-0.000369	-0.000462	-0.001288	-0.001218	-0.001218
11.00	0.00	-0.000333	-0.000525	-0.000898	-0.001482	-0.001846	-0.001846
9.00	0.00	-0.000333	-0.000525	-0.000898	-0.001482	-0.001846	-0.001846
7.50	0.00	-0.000333	-0.000525	-0.000898	-0.001482	-0.001846	-0.001846
6.00	0.00	-0.000333	-0.000525	-0.000898	-0.001482	-0.001846	-0.001846
4.50	0.00	-0.000333	-0.000525	-0.000898	-0.001482	-0.001846	-0.001846
3.00	0.00	-0.000333	-0.000525	-0.000898	-0.001482	-0.001846	-0.001846
1.50	0.00	-0.000333	-0.000525	-0.000898	-0.001482	-0.001846	-0.001846
0.00	0.00	-0.000333	-0.000525	-0.000898	-0.001482	-0.001846	-0.001846
17.00	0.00	-0.000333	-0.000525	-0.000898	-0.001482	-0.001846	-0.001846
15.00	0.00	-0.000333	-0.000525	-0.000898	-0.001482	-0.001846	-0.001846
13.00	0.00	-0.000333	-0.000525	-0.000898	-0.001482	-0.001846	-0.001846
11.00	0.00	-0.000333	-0.000525	-0.000898	-0.001482	-0.001846	-0.001846
9.00	0.00	-0.000333	-0.000525	-0.000898	-0.001482	-0.001846	-0.001846
7.50	0.00	-0.000333	-0.000525	-0.000898	-0.001482	-0.001846	-0.001846
6.00	0.00	-0.000333	-0.000525	-0.000898	-0.001482	-0.001846	-0.001846
4.50	0.00	-0.000333	-0.000525	-0.000898	-0.001482	-0.001846	-0.001846
3.00	0.00	-0.000333	-0.000525	-0.000898	-0.001482	-0.001846	-0.001846
1.50	0.00	-0.000333	-0.000525	-0.000898	-0.001482	-0.001846	-0.001846
0.00	0.00	-0.000333	-0.000525	-0.000898	-0.001482	-0.001846	-0.001846

Force and Moment Summary

h/D <sub>e</sub>	17.72	11.84	8.87	5.91	3.53	2.35
Balance	AL/T = 0.04	-0.068	-0.069	-0.126	-0.267	-0.418
Pressure	AL/T = -0.035	-0.069	-0.064	-0.110	-0.223	-0.395
Balance	AM/T <sub>de</sub> = NOT AVAILABLE	0.103	0.048	0.088	0.158	0.121
Pressure	AM/T <sub>de</sub> =	0.040	0.088	0.158	0.223	0.395



Configuration: 2R-12-0-DW Run 245

Point	1	2	3	4	5	6	7
h/D =	2.35	3.54	4.71	5.91	8.85	11.81	17.70
Total Thrust =	136.43	136.36	136.30	136.26	136.19	136.27	136.24
NPR Front =	4.10	4.10	4.10	4.10	4.10	4.10	4.10
NPR Aft =	4.15	4.14	4.14	4.14	4.14	4.14	4.14
X-loc	ACP	ACP	ACP	ACP	ACP	ACP	ACP
Y-loc	ACP	ACP	ACP	ACP	ACP	ACP	ACP
17.00	-0.003677	-0.000958	-0.000651	-0.000532	-0.000313	-0.000196	-0.000149
15.00	-0.000988	-0.000868	-0.000512	-0.000438	-0.000346	-0.000168	-0.000155
13.00	-0.001211	-0.000904	-0.000632	-0.000739	-0.000434	-0.000142	-0.000161
11.00	-0.002003	-0.001379	-0.001334	-0.001086	-0.000907	-0.000178	-0.000194
9.00	-0.002701	-0.000994	-0.001874	-0.001955	-0.000907	-0.000178	-0.000194
7.50	-0.002212	-0.001460	-0.002113	-0.002038	-0.000741	-0.000238	-0.000238
6.50	-0.000668	-0.001615	-0.002981	-0.003636	-0.001752	-0.000374	-0.000393
5.50	-0.005904	-0.002715	-0.000758	-0.000921	-0.001327	-0.000113	-0.000924
4.50	-0.013148	-0.006429	-0.003498	-0.001632	-0.000658	-0.000308	-0.000585
3.50	-0.010922	-0.004937	-0.002981	-0.001133	-0.000559	-0.000378	-0.000200
2.75	-0.001129	-0.004075	-0.002020	-0.001940	-0.001067	-0.000378	-0.000200
2.00	-0.009105	-0.004714	-0.003872	-0.003456	-0.001504	-0.000339	-0.000131
1.50	-0.016847	-0.007112	-0.006911	-0.004300	-0.001713	-0.000342	-0.000036
0.00	-0.004487	-0.016656	-0.007735	-0.005002	-0.001148	-0.000295	-0.000011
-0.50	-0.013998	-0.005881	-0.004925	-0.003317	-0.000506	-0.000281	-0.000034
-2.00	-0.017149	-0.005839	-0.000999	-0.001133	-0.000280	-0.000255	-0.000048
-2.75	-0.017305	-0.009036	-0.003632	-0.001528	-0.000610	-0.000253	-0.000048
-3.50	-0.012481	-0.005611	-0.003742	-0.001902	-0.001023	-0.000675	-0.000145
-4.50	-0.006079	-0.002300	-0.000587	-0.000031	-0.001118	-0.000847	-0.000152
-5.00	-0.01944	-0.002642	-0.003232	-0.002438	-0.000567	-0.001354	-0.000817
-5.50	-0.04482	-0.004621	-0.004620	-0.003287	-0.002122	-0.001335	-0.000909
-7.00	-0.005075	-0.004695	-0.004156	-0.003074	-0.001473	-0.000802	-0.000294
-7.50	-0.004581	-0.003951	-0.003686	-0.002917	-0.001513	-0.000456	-0.000166
-8.00	-0.004354	-0.003306	-0.003152	-0.002771	-0.001513	-0.000456	-0.000276
-9.25	-0.004439	-0.002691	-0.002840	-0.002235	-0.001147	-0.000563	-0.000258
-10.00	-0.01604	-0.002511	-0.002721	-0.002136	-0.000836	-0.000384	-0.000272
-11.50	-0.001240	-0.003044	-0.002643	-0.001807	-0.000719	-0.000405	-0.000192
7.00	-0.003043	-0.001039	-0.001619	-0.001950	-0.001426	-0.000481	-0.000342
6.50	-0.002601	-0.001984	-0.002793	-0.003389	-0.001426	-0.000481	-0.000342
5.50	-0.003698	-0.002605	-0.002290	-0.001883	-0.001558	-0.001159	-0.000614
5.00	-0.007127	-0.004579	-0.003204	-0.001883	-0.001384	-0.000652	-0.000588
4.50	-0.013870	-0.008315	-0.003405	-0.002959	-0.001423	-0.000318	-0.000448
4.00	-0.005992	-0.006508	-0.003405	-0.002959	-0.001415	-0.000502	-0.000471
3.50	-0.006340	-0.006273	-0.003885	-0.002969	-0.001101	-0.000270	-0.000164
3.00	-0.007031	-0.005309	-0.001802	-0.001556	-0.002031	-0.000951	-0.000902
2.50	-0.005146	-0.004341	-0.004629	-0.003344	-0.001453	-0.000476	-0.000118
2.00	-0.009806	-0.007332	-0.014804	-0.007681	-0.009553	-0.001922	-0.001153
1.50	-0.003013	-0.001157	-0.000985	-0.000796	-0.001251	-0.000366	-0.000070
1.00	-0.002393	-0.003055	-0.001937	-0.001231	-0.000816	-0.000344	-0.000206
0.50	-0.003172	-0.001398	-0.001092	-0.000825	-0.001375	-0.000365	-0.000208
0.00	-0.002891	-0.003572	-0.002597	-0.002029	-0.001415	-0.000407	-0.000148
7.50	-0.003761	-0.003576	-0.003075	-0.003318	-0.001447	-0.000594	-0.000450
6.50	-0.004761	-0.003591	-0.004649	-0.003558	-0.003429	-0.000730	-0.000370
5.50	-0.006053	-0.004710	-0.006517	-0.005517	-0.003252	-0.000943	-0.000723
5.00	-0.008027	-0.004771	-0.007271	-0.005728	-0.002357	-0.000566	-0.000309
4.50	-0.010116	-0.006371	-0.005378	-0.003752	-0.001405	-0.000404	-0.000309
4.00	-0.013472	-0.007746	-0.004505	-0.002174	-0.000424	-0.000415	-0.000433
3.50	-0.014694	-0.007746	-0.004505	-0.002174	-0.000424	-0.000415	-0.000433
3.00	-0.011496	-0.009876	-0.006674	-0.005221	-0.000976	-0.000515	-0.000169
2.50	-0.011336	-0.003352	-0.000365	-0.001446	-0.000015	-0.000245	-0.000070
2.00	-0.014866	-0.010161	-0.004188	-0.001513	-0.000528	-0.000249	-0.000106
1.50	-0.012515	-0.010178	-0.006655	-0.004754	-0.001881	-0.000367	-0.000812
1.00	-0.007775	-0.011580	-0.009201	-0.004755	-0.002462	-0.000547	-0.0000541
0.50	-0.009449	-0.013142	-0.010535	-0.007964	-0.003910	-0.001435	-0.001074
-6.50	-0.006936	-0.007835	-0.006278	-0.005278	-0.003671	-0.000859	-0.000735

Force and Moment Summary

h/D =	2.35	3.54	4.71	5.91	8.85	11.81	17.70
Balance	-0.407	-0.299	-0.215	-0.143	-0.075	-0.049	-0.026
Pressure	-0.367	-0.267	-0.198	-0.124	-0.065	-0.032	-0.027
Balance	0.289	0.388	0.321	0.223	0.136	0.059	0.025
Pressure	0.205	0.353	0.307	0.223	0.099	0.073	0.032





Configuration: 2R-12-0-DW Run 248

Point	1	2	3	4	5	6	7	8
h/D <sub>e</sub> =	33.99	17.72	11.81	8.86	5.90	4.72	3.55	2.35
Total Thrust =	136.02	135.46	135.56	135.50	135.48	135.46	135.51	135.53
NPR Front =	4.11	4.10	4.11	4.11	4.11	4.11	4.11	4.11
NPR Aft =	4.15	4.13	4.13	4.13	4.13	4.13	4.13	4.13
X-loc	Y-loc	ACP	ACP	ACP	ACP	ACP	ACP	ACP
17.00	0.00	0.00	0.00	0.00	0.00	0.00	0.00	0.00
15.00	0.00	0.00	0.00	0.00	0.00	0.00	0.00	0.00
13.00	0.00	0.00	0.00	0.00	0.00	0.00	0.00	0.00
11.00	0.00	0.00	0.00	0.00	0.00	0.00	0.00	0.00
9.50	0.00	0.00	0.00	0.00	0.00	0.00	0.00	0.00
7.50	0.00	0.00	0.00	0.00	0.00	0.00	0.00	0.00
6.50	0.00	0.00	0.00	0.00	0.00	0.00	0.00	0.00
5.50	0.00	0.00	0.00	0.00	0.00	0.00	0.00	0.00
4.50	0.00	0.00	0.00	0.00	0.00	0.00	0.00	0.00
3.50	0.00	0.00	0.00	0.00	0.00	0.00	0.00	0.00
2.75	0.00	0.00	0.00	0.00	0.00	0.00	0.00	0.00
2.00	0.00	0.00	0.00	0.00	0.00	0.00	0.00	0.00
1.25	0.00	0.00	0.00	0.00	0.00	0.00	0.00	0.00
0.50	0.00	0.00	0.00	0.00	0.00	0.00	0.00	0.00
-0.50	0.00	0.00	0.00	0.00	0.00	0.00	0.00	0.00
-1.25	0.00	0.00	0.00	0.00	0.00	0.00	0.00	0.00
-2.00	0.00	0.00	0.00	0.00	0.00	0.00	0.00	0.00
-2.75	0.00	0.00	0.00	0.00	0.00	0.00	0.00	0.00
-3.50	0.00	0.00	0.00	0.00	0.00	0.00	0.00	0.00
-4.50	0.00	0.00	0.00	0.00	0.00	0.00	0.00	0.00
-5.50	0.00	0.00	0.00	0.00	0.00	0.00	0.00	0.00
-6.50	0.00	0.00	0.00	0.00	0.00	0.00	0.00	0.00
-7.50	0.00	0.00	0.00	0.00	0.00	0.00	0.00	0.00
-8.50	0.00	0.00	0.00	0.00	0.00	0.00	0.00	0.00
-9.25	0.00	0.00	0.00	0.00	0.00	0.00	0.00	0.00
-10.00	0.00	0.00	0.00	0.00	0.00	0.00	0.00	0.00
-10.75	0.00	0.00	0.00	0.00	0.00	0.00	0.00	0.00
-11.50	0.00	0.00	0.00	0.00	0.00	0.00	0.00	0.00
7.00	0.75	0.003217	0.000284	0.000314	0.000314	0.000314	0.000314	0.000314
7.50	0.75	0.003364	0.000898	0.001206	0.001206	0.001206	0.001206	0.001206
6.50	0.75	0.000725	0.000898	0.001206	0.001206	0.001206	0.001206	0.001206
5.50	0.75	0.000482	0.000641	0.000594	0.000594	0.000594	0.000594	0.000594
5.00	0.75	0.000291	0.000518	0.000383	0.000383	0.000383	0.000383	0.000383
4.50	0.75	0.000237	0.000284	0.000284	0.000284	0.000284	0.000284	0.000284
4.00	0.75	0.000337	0.000314	0.000314	0.000314	0.000314	0.000314	0.000314
3.50	0.75	0.000864	0.001109	0.001141	0.001141	0.001141	0.001141	0.001141
3.00	0.75	0.001612	0.001109	0.001109	0.001109	0.001109	0.001109	0.001109
2.50	0.75	0.000265	0.000649	0.000646	0.000646	0.000646	0.000646	0.000646
2.00	0.75	0.000238	0.000250	0.000249	0.000249	0.000249	0.000249	0.000249
1.50	0.75	0.000700	0.001840	0.002049	0.002049	0.002049	0.002049	0.002049
1.00	1.13	0.001307	0.001895	0.001413	0.001413	0.001413	0.001413	0.001413
0.50	1.13	0.000993	0.000184	0.000298	0.000298	0.000298	0.000298	0.000298
0.00	1.50	0.000136	0.000209	0.000353	0.000353	0.000353	0.000353	0.000353
11.00	1.50	0.000080	0.000196	0.000270	0.000270	0.000270	0.000270	0.000270
9.00	1.50	0.000239	0.000482	0.000474	0.000474	0.000474	0.000474	0.000474
7.50	1.50	0.000280	0.000223	0.000576	0.000576	0.000576	0.000576	0.000576
7.00	1.50	0.000222	0.000408	0.000918	0.000918	0.000918	0.000918	0.000918
6.50	1.50	0.000382	0.000343	0.000923	0.000923	0.000923	0.000923	0.000923
6.00	1.50	0.000382	0.000565	0.000633	0.000633	0.000633	0.000633	0.000633
5.50	1.50	0.000514	0.000715	0.000403	0.000403	0.000403	0.000403	0.000403
5.00	1.50	0.000226	0.000390	0.000407	0.000407	0.000407	0.000407	0.000407
4.50	1.50	0.000253	0.000336	0.000336	0.000336	0.000336	0.000336	0.000336
4.00	1.50	0.000453	0.000376	0.000376	0.000376	0.000376	0.000376	0.000376
3.50	1.50	0.000019	0.000176	0.000347	0.000347	0.000347	0.000347	0.000347
3.00	1.50	0.000046	0.000143	0.000386	0.000386	0.000386	0.000386	0.000386
2.50	1.50	0.000023	0.000040	0.000357	0.000357	0.000357	0.000357	0.000357
2.00	1.50	0.000032	0.000076	0.000457	0.000457	0.000457	0.000457	0.000457
1.50	1.50	0.000165	0.000245	0.000378	0.000378	0.000378	0.000378	0.000378
1.00	1.50	0.000249	0.000245	0.000378	0.000378	0.000378	0.000378	0.000378
0.50	1.50	0.000406	0.000245	0.000378	0.000378	0.000378	0.000378	0.000378
-0.50	1.50	0.000781	0.000802	0.001104	0.001104	0.001104	0.001104	0.001104
-1.00	1.50	0.000637	0.000755	0.000909	0.000909	0.000909	0.000909	0.000909
-1.50	1.50	0.000637	0.000755	0.000909	0.000909	0.000909	0.000909	0.000909
-2.00	1.50	0.000637	0.000755	0.000909	0.000909	0.000909	0.000909	0.000909
-2.50	1.50	0.000637	0.000755	0.000909	0.000909	0.000909	0.000909	0.000909
-3.00	1.50	0.000637	0.000755	0.000909	0.000909	0.000909	0.000909	0.000909
-3.50	1.50	0.000637	0.000755	0.000909	0.000909	0.000909	0.000909	0.000909
-4.00	1.50	0.000637	0.000755	0.000909	0.000909	0.000909	0.000909	0.000909
-4.50	1.50	0.000637	0.000755	0.000909	0.000909	0.000909	0.000909	0.000909
-5.00	1.50	0.000637	0.000755	0.000909	0.000909	0.000909	0.000909	0.000909
-5.50	1.50	0.000637	0.000755	0.000909	0.000909	0.000909	0.000909	0.000909
-6.00	1.50	0.000637	0.000755	0.000909	0.000909	0.000909	0.000909	0.000909
-6.50	1.50	0.000637	0.000755	0.000909	0.000909	0.000909	0.000909	0.000909
-7.00	1.50	0.000637	0.000755	0.000909	0.000909	0.000909	0.000909	0.000909
-7.50	1.50	0.000637	0.000755	0.000909	0.000909	0.000909	0.000909	0.000909
-8.00	1.50	0.000637	0.000755	0.000909	0.000909	0.000909	0.000909	0.000909
-8.50	1.50	0.000637	0.000755	0.000909	0.000909	0.000909	0.000909	0.000909
-9.00	1.50	0.000637	0.000755	0.000909	0.000909	0.000909	0.000909	0.000909
-9.50	1.50	0.000637	0.000755	0.000909	0.000909	0.000909	0.000909	0.000909
-10.00	1.50	0.000637	0.000755	0.000909	0.000909	0.000909	0.000909	0.000909
-10.50	1.50	0.000637	0.000755	0.000909	0.000909	0.000909	0.000909	0.000909
-11.00	1.50	0.000637	0.000755	0.000909	0.000909	0.000909	0.000909	0.000909

Force and Moment Summary

Point	1	2	3	4	5	6	7	8
h/D <sub>e</sub> =	33.99	17.72	11.81	8.86	5.90	4.72	3.55	2.35
Balance ΔL/T =	-0.020	-0.028	-0.050	-0.066	-0.145	-0.211	-0.286	-0.360
Pressure ΔL/T =	0.018	-0.032	-0.051	-0.077	-0.136	-0.195	-0.263	-0.330
Balance ΔM/TDe =	0.018	0.026	0.045	0.074	0.135	0.210	0.311	0.259
Pressure ΔM/TDe =	0.020	0.032	0.064	0.098	0.207	0.289	0.334	0.194

Configuration: 2R-12-0-DW Jet-Induced Pressure Increments Run 249

Thrust split 0.45/0.55 front/eft

Point	1	2	3	4
h/De =	2.38	3.54	51.05	5.90
Total Thrust =	51.27	51.12	51.05	51.00
NPR Front =	1.97	1.97	1.97	1.97
NPR Aft =	2.20	2.20	2.20	2.20
X-loc	Y-loc	ACp	ACp	ACp
17.00	0.00	-0.000502	-0.000689	-0.000411
15.00	0.00	-0.000542	-0.000428	-0.000464
13.00	0.00	-0.000858	-0.000790	-0.000932
11.00	0.00	-0.001896	-0.001454	-0.001326
9.00	0.00	-0.001896	-0.001454	-0.001326
7.00	0.00	-0.006050	-0.004019	-0.004257
6.00	0.00	-0.006277	-0.005348	-0.004796
5.00	0.00	-0.007324	-0.006893	-0.006367
5.00	0.00	-0.007263	-0.003993	0.005046
5.00	0.00	-0.008203	-0.001093	0.001482
4.50	0.00	-0.012962	-0.004432	0.000974
3.50	0.00	-0.012092	-0.002010	0.002044
2.75	0.00	-0.036592	0.005131	0.006433
2.00	0.00	-0.082020	0.009278	0.007908
1.25	0.00	-0.123997	0.011996	0.007781
0.50	0.00	-0.123997	0.007866	0.004037
-0.50	0.00	-0.040311	0.000142	-0.001319
-1.25	0.00	-0.048111	-0.008256	-0.004712
-2.00	0.00	-0.014231	-0.009387	-0.005859
-2.75	0.00	-0.014231	-0.00076	-0.005626
-3.50	0.00	-0.009363	-0.006187	-0.00567
-4.50	0.00	-0.012310	-0.003752	-0.001900
-5.00	0.00	-0.05208	-0.04514	-0.004425
-6.00	0.00	-0.05222	-0.03730	-0.002900
-7.00	0.00	-0.03954	-0.03495	-0.002830
-8.00	0.00	-0.02464	-0.02654	-0.002338
-9.25	0.00	-0.01944	-0.02087	-0.001994
-10.00	0.00	-0.02192	-0.02123	-0.002080
-11.50	0.00	-0.05530	-0.05116	-0.005416
7.00	0.75	-0.00361	-0.006721	-0.006097
6.50	0.75	-0.009459	-0.017434	-0.017831
6.00	0.75	-0.005054	-0.001347	-0.000707
5.50	0.75	-0.010841	-0.005021	-0.00125
5.00	0.75	-0.01422	-0.006545	-0.003114
4.50	0.75	-0.01257	-0.007797	-0.005309
4.00	0.75	-0.009169	-0.005701	-0.005214
3.50	0.75	-0.006959	-0.006054	-0.004981
3.00	0.75	-0.006041	-0.003924	-0.004120
2.50	0.75	-0.006354	-0.004006	-0.003132
2.00	1.13	-0.026812	-0.036514	-0.027287
1.50	1.13	-0.010031	-0.009200	-0.007963
1.00	1.50	-0.003602	-0.002164	-0.002389
0.50	1.50	-0.002253	-0.001968	-0.001366
0.00	1.50	-0.004761	-0.001213	-0.003014
7.00	1.50	-0.005367	-0.005241	-0.004365
6.50	1.50	-0.007272	-0.006799	-0.004960
6.00	1.50	-0.009943	-0.007646	-0.007274
5.50	1.50	-0.013516	-0.016481	-0.013005
5.00	1.50	-0.015399	-0.012006	-0.007812
4.50	1.50	-0.014220	-0.009350	-0.003982
4.00	1.50	-0.015889	-0.008171	-0.002305
3.50	1.50	-0.013570	-0.003526	0.003319
3.00	1.50	0.014623	0.008677	0.004170
2.50	1.50	0.004010	0.001383	0.000173
2.00	1.50	-0.014617	-0.008357	-0.004378
1.50	1.50	-0.014309	-0.010693	-0.005986
1.00	1.50	-0.012988	-0.008726	-0.006153
0.50	1.50	-0.011988	-0.008459	-0.007260
0.00	1.50	-0.009723	-0.008265	-0.006468
-0.50	1.50	-0.009430	-0.007181	-0.005252
-1.00	1.50	-0.007087	-0.005125	-0.004012
-1.50	1.50	-0.007087	-0.005125	-0.002911

Force and Moment Summary

h/De =	2.38	3.54	4.72	5.90
Balance AL/T =	-0.412	-0.287	-0.211	-0.164
Pressure AL/T =	-0.420	-0.289	-0.199	-0.171
Balance AM/TDe =	0.164	0.266	0.279	0.246
Pressure AM/TDe =	0.230	0.319	0.281	0.217

Configuration: 2R-12-0-DM Jet-Induced Pressure Increments Run 230 Thrust split 0.45/0.55 front/aft

Point	1	2	3	4	5	6	1	2	3	4	5	6
h/De	2.35	2.34	3.55	4.72	5.89	8.86	2.35	2.34	3.55	4.72	5.89	8.86
Total Thrust	136.59	136.59	136.47	136.42	136.22	136.39	136.59	136.59	136.47	136.42	136.42	136.39
NPR	3.77	3.77	3.77	3.77	3.77	3.77	3.77	3.77	3.77	3.77	3.77	3.77
Aft	4.53	4.53	4.53	4.53	4.53	4.52	4.53	4.53	4.53	4.53	4.53	4.52
X-loc	Y-loc	Y-loc	ACP	ACP	ACP	ACP	ACP	ACP	ACP	ACP	ACP	ACP
17.00	0.00	-0.000399	-0.000384	-0.000403	-0.000434	-0.000241	-0.000372	-0.000380	-0.000433	-0.000270	-0.000422	-0.000487
15.00	0.00	-0.000380	-0.000384	-0.000123	-0.000387	-0.000390	-0.000361	-0.000310	-0.000316	-0.000257	-0.000270	-0.000287
13.00	0.00	-0.000781	-0.000849	-0.000762	-0.000867	-0.000867	-0.000907	-0.000784	-0.000784	-0.000769	-0.000784	-0.000815
11.00	0.00	-0.001819	-0.001883	-0.001670	-0.001228	-0.001426	-0.002523	-0.002643	-0.002501	-0.002182	-0.002158	-0.002135
9.00	0.00	-0.001819	-0.001883	-0.001670	-0.001228	-0.001426	-0.002523	-0.002643	-0.002501	-0.002182	-0.002158	-0.002135
7.50	0.00	-0.003368	-0.004912	-0.004245	-0.002939	-0.002946	-0.002011	-0.002011	-0.002286	-0.001999	-0.001999	-0.000847
7.00	0.00	-0.005351	-0.005490	-0.004401	-0.003368	-0.003059	-0.002011	-0.002011	-0.002286	-0.001999	-0.001999	-0.000847
6.50	0.00	-0.007382	-0.003908	-0.005663	-0.004336	-0.003400	-0.004546	-0.003562	-0.003562	-0.003093	-0.003093	-0.000676
5.50	0.00	-0.004508	-0.003368	-0.006473	-0.005258	-0.004405	-0.003813	-0.003400	-0.004445	-0.003585	-0.003585	-0.000319
5.00	0.00	-0.004413	-0.004981	-0.004017	-0.003945	-0.002115	-0.003813	-0.003400	-0.004445	-0.003585	-0.003585	-0.000319
4.50	0.00	-0.011458	-0.011918	-0.004701	-0.001669	-0.000671	-0.012022	-0.015944	-0.004606	-0.002614	-0.002614	-0.000344
3.50	0.00	-0.012289	-0.012446	-0.004768	-0.001146	-0.000874	-0.013197	-0.014081	-0.004606	-0.002614	-0.002614	-0.000344
2.75	0.00	-0.005148	-0.005549	-0.004205	-0.003178	-0.002440	-0.003616	-0.005174	-0.004606	-0.002614	-0.002614	-0.000344
2.00	0.00	-0.007143	-0.005996	-0.004724	-0.003996	-0.003450	-0.003616	-0.005174	-0.004606	-0.002614	-0.002614	-0.000344
1.25	0.00	-0.017633	-0.015442	-0.011356	-0.007202	-0.004884	-0.013197	-0.014849	-0.008807	-0.005286	-0.005286	-0.001378
0.50	0.00	-0.000844	-0.000315	-0.003930	-0.004384	-0.000412	-0.005883	-0.004133	-0.004133	-0.003194	-0.003194	-0.000539
-0.50	0.00	-0.013170	-0.010513	-0.005908	-0.001909	-0.001433	-0.005883	-0.004133	-0.004133	-0.003194	-0.003194	-0.000539
-1.25	0.00	-0.014964	-0.015501	-0.007743	-0.004022	-0.003275	-0.005883	-0.004133	-0.004133	-0.003194	-0.003194	-0.000539
-2.00	0.00	-0.017479	-0.015048	-0.008857	-0.004915	-0.003051	-0.005883	-0.004133	-0.004133	-0.003194	-0.003194	-0.000539
-3.50	0.00	-0.018178	-0.017169	-0.007135	-0.004458	-0.002876	-0.005883	-0.004133	-0.004133	-0.003194	-0.003194	-0.000539
-4.50	0.00	-0.018178	-0.008076	-0.003977	-0.002064	-0.001972	-0.005883	-0.004133	-0.004133	-0.003194	-0.003194	-0.000539
-5.50	0.00	-0.005183	-0.003495	-0.002705	-0.000409	-0.000914	-0.005883	-0.004133	-0.004133	-0.003194	-0.003194	-0.000539
-6.50	0.00	-0.004455	-0.004499	-0.003048	-0.002705	-0.002614	-0.005883	-0.004133	-0.004133	-0.003194	-0.003194	-0.000539
-7.50	0.00	-0.004455	-0.004499	-0.003048	-0.002705	-0.002614	-0.005883	-0.004133	-0.004133	-0.003194	-0.003194	-0.000539
-8.50	0.00	-0.003189	-0.003376	-0.002990	-0.002678	-0.002143	-0.005883	-0.004133	-0.004133	-0.003194	-0.003194	-0.000539
-9.25	0.00	-0.002343	-0.002305	-0.002558	-0.002245	-0.001902	-0.005883	-0.004133	-0.004133	-0.003194	-0.003194	-0.000539
-10.00	0.00	-0.002343	-0.002305	-0.002558	-0.002245	-0.001902	-0.005883	-0.004133	-0.004133	-0.003194	-0.003194	-0.000539
-11.75	0.00	-0.002110	-0.003124	-0.002446	-0.002346	-0.001828	-0.005883	-0.004133	-0.004133	-0.003194	-0.003194	-0.000539
-13.50	0.75	-0.005414	-0.003138	-0.004728	-0.005761	-0.003247	-0.005883	-0.004133	-0.004133	-0.003194	-0.003194	-0.000539
1.50	0.75	-0.005886	-0.007138	-0.015542	-0.007743	-0.005454	-0.005883	-0.004133	-0.004133	-0.003194	-0.003194	-0.000539
3.50	0.75	-0.008000	-0.001965	-0.012238	-0.001195	-0.001195	-0.005883	-0.004133	-0.004133	-0.003194	-0.003194	-0.000539
5.50	0.75	-0.008070	-0.008628	-0.003333	-0.001541	-0.000118	-0.005883	-0.004133	-0.004133	-0.003194	-0.003194	-0.000539
7.50	0.75	-0.013599	-0.011650	-0.007816	-0.004891	-0.002994	-0.005883	-0.004133	-0.004133	-0.003194	-0.003194	-0.000539
9.50	0.75	-0.007553	-0.009100	-0.003976	-0.003995	-0.003226	-0.005883	-0.004133	-0.004133	-0.003194	-0.003194	-0.000539
11.50	0.75	-0.007549	-0.008027	-0.004087	-0.004528	-0.003211	-0.005883	-0.004133	-0.004133	-0.003194	-0.003194	-0.000539
13.50	0.75	-0.005672	-0.005521	-0.003670	-0.005586	-0.005695	-0.005883	-0.004133	-0.004133	-0.003194	-0.003194	-0.000539
15.50	0.75	-0.004846	-0.003351	-0.003241	-0.003628	-0.003019	-0.005883	-0.004133	-0.004133	-0.003194	-0.003194	-0.000539
17.50	0.75	-0.004846	-0.003399	-0.002987	-0.003252	-0.002299	-0.005883	-0.004133	-0.004133	-0.003194	-0.003194	-0.000539
19.50	1.13	-0.021978	-0.023399	-0.025708	-0.021083	-0.018580	-0.005883	-0.004133	-0.004133	-0.003194	-0.003194	-0.000539
21.50	1.50	-0.008387	-0.001559	-0.005697	-0.013437	-0.008351	-0.005883	-0.004133	-0.004133	-0.003194	-0.003194	-0.000539
23.50	1.50	-0.004359	-0.004193	-0.002236	-0.001944	-0.002410	-0.005883	-0.004133	-0.004133	-0.003194	-0.003194	-0.000539
25.50	1.50	-0.006244	-0.002059	-0.002869	-0.001126	-0.001742	-0.005883	-0.004133	-0.004133	-0.003194	-0.003194	-0.000539
27.50	1.50	-0.005844	-0.004808	-0.002343	-0.002199	-0.002612	-0.005883	-0.004133	-0.004133	-0.003194	-0.003194	-0.000539
29.50	1.50	-0.005810	-0.005008	-0.004371	-0.003453	-0.002665	-0.005883	-0.004133	-0.004133	-0.003194	-0.003194	-0.000539
31.50	1.50	-0.007320	-0.007832	-0.006550	-0.004395	-0.004061	-0.005883	-0.004133	-0.004133	-0.003194	-0.003194	-0.000539
33.50	1.50	-0.008241	-0.007832	-0.008887	-0.006310	-0.006502	-0.005883	-0.004133	-0.004133	-0.003194	-0.003194	-0.000539
35.50	1.50	-0.011346	-0.012856	-0.013849	-0.009948	-0.008526	-0.005883	-0.004133	-0.004133	-0.003194	-0.003194	-0.000539
37.50	1.50	-0.011855	-0.012856	-0.010599	-0.008189	-0.005603	-0.005883	-0.004133	-0.004133	-0.003194	-0.003194	-0.000539
39.50	1.50	-0.012234	-0.013407	-0.008484	-0.005976	-0.002977	-0.005883	-0.004133	-0.004133	-0.003194	-0.003194	-0.000539
41.50	1.50	-0.014269	-0.014177	-0.007105	-0.004305	-0.000901	-0.005883	-0.004133	-0.004133	-0.003194	-0.003194	-0.000539
43.50	1.50	-0.014029	-0.014331	-0.005158	-0.002471	-0.001111	-0.005883	-0.004133	-0.004133	-0.003194	-0.003194	-0.000539
45.50	1.50	-0.017022	-0.016964	-0.010158	-0.006584	-0.003333	-0.005883	-0.004133	-0.004133	-0.003194	-0.003194	-0.000539
47.50	1.50	-0.023887	-0.017771	-0.009339	-0.003984	-0.000822	-0.005883	-0.004133	-0.004133	-0.003194	-0.003194	-0.000539
49.50	1.50	-0.014433	-0.013886	-0.008657	-0.002746	-0.001743	-0.005883	-0.004133	-0.004133	-0.003194	-0.003194	-0.000539
51.50	1.50	-0.015209	-0.014876	-0.008853	-0.005147	-0.003380	-0.005883	-0.004133	-0.004133	-0.003194	-0.003194	-0.000539
53.50	1.50	-0.011478	-0.012152	-0.008037	-0.005847	-0.003691	-0.005883	-0.004133	-0.004133	-0.003194	-0.003194	-0.000539
55.50	1.50	-0.009374	-0.010035	-0.006695	-0.005251	-0.003691	-0.005883	-0.004133	-0.004133	-0.003194	-0.003194	-0.000539
57.50	1.50	-0.007696	-0.007627	-0.004976	-0.004976	-0.004948	-0.005883	-0.004133	-0.004133	-0.003194	-0.003194	-0.000539
59.50	1.50	-0.007396	-0.006963	-0.004133	-0.004133	-0.004133	-0.005883	-0.004133	-0.004133	-0.003194	-0.003194	-0.000539
61.50	1.50	-0.007429	-0.006924	-0.004381	-0.004822	-0.003595	-0.005883	-0.004133	-0.004133	-0.003194	-0.003194	-0.000539

Force and Moment Summary  
 h/De = 2.35  
 Balance AL/T = -0.422  
 Pressure AL/T = -0.411  
 Balance AM/TDe = 0.220  
 Pressure AM/TDe = 0.249



## Pressure Orifice Locations and Weighting Factors

Conf. # 2R\_12\_0\_16/8

Distance from balance center to moment reference point,  $X_0 = 2$

Orif. #	Mom. arm	Sta. y	$\Delta$ .Area	Sta. x
165	7.5	3	5.313	7.5
166	7.5	1.5	1.125	7.5
167	7.5	0.75	1.125	7.5
168	7.5	0	0.563	7.5
169	7	1.5	0.75	7
170	7	0.75	0.75	7
171	7	0	0.375	7
172	6.5	1.5	0.625	6.5
173	6.5	0.75	0.578	6.5
174	6.5	0	0.295	6.5
175	6	3	6.375	6
176	6	1.5	0.625	6
177	6	1.125	0.62	6
178	5.5	1.5	0.625	5.5
179	5.5	0.75	0.578	5.5
180	5.5	0	0.295	5.5
181	5	1.5	0.75	5
182	5	0.75	0.75	5
183	5	0	0.375	5
184	4.5	3	5.313	4.5
185	4.5	1.5	1.125	4.5
186	4.5	0.75	1.125	4.5
187	4.5	0	0.563	4.5
47	3.5	0	1.313	3.5
48	2.75	0	1.125	2.75
49	2	0	1.125	2
50	1.25	0	1.125	1.25
51	0.5	0	1.313	0.5
52	3.5	1.5	3.75	3.5
53	2	1.5	4.5	2
54	0.5	1.5	3.75	0.5
55	3.5	3	4.375	3.5
56	2	3	5.25	2
57	0.5	3	4.375	0.5
36	-0.5	0	1.313	-0.5
37	-1.25	0	1.125	-1.25
38	-2	0	1.125	-2
39	-2.75	0	1.125	-2.75
40	-3.5	0	1.313	-3.5
41	-0.5	1.5	3.75	-0.5
42	-2	1.5	4.5	-2
43	-3.5	1.5	3.75	-3.5
44	-0.5	3	4.375	-0.5
45	-2	3	5.25	-2
46	-3.5	3	4.375	-3.5
188	-4.5	3	5.313	-4.5



Conf. # 2R\_12\_0\_16/8, continued

Orif. #	Mom. arm	Sta. y	$\Delta$ .Area	Sta. x
189	-4.5	1.5	1.125	-4.5
190	-4.5	0.75	1.125	-4.5
191	-4.5	0	0.563	-4.5
192	-5	1.5	0.75	-5
193	-5	0.75	0.75	-5
194	-5	0	0.375	-5
195	-5.5	1.5	0.625	-5.5
196	-5.5	0.75	0.578	-5.5
197	-5.5	0	0.295	-5.5
198	-6	3	6.375	-6
199	-6	1.5	0.625	-6
200	-6	1.125	0.62	-6
201	-6.5	1.5	0.625	-6.5
202	-6.5	0.75	0.578	-6.5
203	-6.5	0	0.295	-6.5
204	-7	1.5	0.75	-7
205	-7	0.75	0.75	-7
206	-7	0	0.375	-7
207	-7.5	3	5.313	-7.5
208	-7.5	1.5	1.125	-7.5
209	-7.5	0.75	1.125	-7.5
210	-7.5	0	0.563	-7.5

Point	1	2	3	4	5	6	7	8	9	10
h/Dw =	35.17	17.73	11.82	8.85	5.90	4.71	3.53	2.33	1.16	1.74
Total Throat =	53.54	53.12	52.99	52.95	53.05	53.36	53.07	53.02	53.05	53.02
NPR Front =	2.15	2.14	2.13	2.13	2.13	2.14	2.14	2.13	2.13	2.13
NPR Aft =	2.15	2.14	2.13	2.13	2.13	2.14	2.13	2.13	2.13	2.13
X-loc	1-loc	2-loc	3-loc	4-loc	5-loc	6-loc	7-loc	8-loc	9-loc	10-loc
7.50	0.00	-0.001064	-0.001071	-0.000843	-0.001890	-0.002003	-0.002802	-0.003494	-0.004648	-0.003440
7.00	0.00	-0.001081	-0.001296	-0.001379	-0.002749	-0.002770	-0.003983	-0.004418	-0.005349	-0.004269
6.50	0.00	-0.001278	-0.001805	-0.001714	-0.004777	-0.004592	-0.005832	-0.004596	-0.005050	-0.005136
6.00	0.00	-0.001392	-0.001936	-0.001278	-0.003631	0.002737	0.001240	-0.001103	-0.003450	-0.002759
5.50	0.00	-0.000645	-0.001394	-0.000934	-0.000934	-0.000934	-0.004208	-0.008599	-0.011656	-0.011242
5.00	0.00	-0.000777	-0.001394	-0.000935	-0.000935	-0.000935	-0.007134	-0.012896	-0.018443	-0.015888
4.50	0.00	-0.000937	-0.00137	-0.000659	-0.001923	-0.004067	-0.007691	-0.013062	-0.026420	-0.018765
4.00	0.00	-0.000073	-0.000171	-0.000658	-0.001139	-0.002140	-0.004836	-0.011053	-0.029566	-0.018297
3.50	0.00	-0.000445	-0.000327	-0.000515	-0.000278	-0.002286	-0.001844	-0.002198	-0.025960	-0.010809
3.00	0.00	-0.000446	-0.000258	-0.000545	-0.000545	-0.000545	-0.006504	-0.007038	-0.003490	-0.008190
2.50	0.00	-0.000024	-0.000195	-0.000659	-0.001785	-0.005145	-0.009895	-0.011445	-0.046515	-0.033873
2.00	0.00	-0.000087	-0.000034	-0.000214	-0.000176	-0.000258	-0.001387	-0.019035	-0.046864	-0.028989
-1.25	0.00	-0.000087	-0.000034	-0.000214	-0.000176	-0.000258	-0.001387	-0.019035	-0.046864	-0.028989
-2.00	0.00	-0.000000	-0.000497	-0.000552	-0.003290	-0.001597	-0.001289	-0.007116	-0.025620	-0.013830
-2.75	0.00	-0.000024	-0.000107	-0.000792	-0.000177	-0.000177	-0.002047	-0.013062	-0.027704	-0.019420
-3.50	0.00	-0.001147	-0.000600	-0.000846	-0.001321	-0.001457	-0.007847	-0.013896	-0.024940	-0.017880
-4.50	0.00	-0.000974	-0.001396	-0.001457	-0.001519	-0.002448	-0.007242	-0.010956	-0.017610	-0.014416
-5.00	0.00	-0.001315	-0.001396	-0.001519	-0.001519	-0.002448	-0.007242	-0.010956	-0.017610	-0.014416
-5.50	0.00	-0.002251	-0.001967	-0.001834	-0.002409	-0.004457	-0.003143	-0.006684	-0.009301	-0.008604
-6.00	0.00	-0.001586	-0.000862	-0.000946	-0.001101	-0.002459	-0.005638	-0.004846	-0.005883	-0.005497
-7.00	0.00	-0.001463	-0.001366	-0.000984	-0.000964	-0.002459	-0.005638	-0.004846	-0.005883	-0.005497
7.50	0.75	-0.001134	-0.001416	-0.000955	-0.001222	-0.002472	-0.003368	-0.003029	-0.004735	-0.004530
7.00	0.75	-0.001454	-0.001532	-0.000959	-0.001458	-0.003368	-0.004137	-0.005242	-0.003713	-0.006208
6.50	0.75	-0.001635	-0.002745	-0.001922	-0.006614	-0.017004	-0.014957	-0.013550	-0.008574	-0.016496
6.00	0.75	-0.001118	-0.001255	-0.001652	-0.002562	-0.004221	-0.002818	-0.005489	-0.006555	-0.007978
5.50	0.75	-0.000752	-0.000998	-0.001537	-0.002562	-0.004221	-0.002818	-0.005489	-0.006555	-0.007978
5.00	0.75	-0.000411	-0.000323	-0.000631	-0.000519	-0.002144	-0.002441	-0.011862	-0.019634	-0.016960
4.50	0.75	-0.000887	-0.000617	-0.001336	-0.001541	-0.002348	-0.004241	-0.006038	-0.011862	-0.014943
4.00	0.75	-0.000916	-0.002091	-0.001573	-0.002405	-0.002840	-0.004241	-0.006038	-0.011862	-0.014943
3.50	0.75	-0.002054	-0.002186	-0.003952	-0.002700	-0.002575	-0.003413	-0.003710	-0.004622	-0.004896
3.00	0.75	-0.001068	-0.002017	-0.001851	-0.001866	-0.003044	-0.004357	-0.007654	-0.003800	-0.003555
2.50	0.75	-0.001015	-0.001706	-0.001345	-0.001392	-0.002836	-0.002445	-0.005116	-0.016453	-0.017933
2.00	1.13	-0.001651	-0.001441	-0.002790	-0.009643	-0.161115	-0.016115	-0.016115	-0.016115	-0.016115
1.50	1.50	-0.001914	-0.001946	-0.003325	-0.011092	-0.028663	-0.023395	-0.023395	-0.023395	-0.023395
1.00	1.50	-0.001040	-0.001495	-0.000855	-0.001259	-0.002222	-0.003392	-0.002333	-0.005879	-0.006544
0.50	1.50	-0.000756	-0.001072	-0.000843	-0.001366	-0.004080	-0.004505	-0.002333	-0.007264	-0.008339
0.00	1.50	-0.000707	-0.001238	-0.001478	-0.005336	-0.005950	-0.006777	-0.012452	-0.009657	-0.011956
-0.50	1.50	-0.000546	-0.000687	-0.000942	-0.004470	-0.010125	-0.010125	-0.011156	-0.012633	-0.013463
-1.00	1.50	-0.000546	-0.000687	-0.000942	-0.004470	-0.010125	-0.010125	-0.011156	-0.012633	-0.013463
-1.50	1.50	-0.000546	-0.000687	-0.000942	-0.004470	-0.010125	-0.010125	-0.011156	-0.012633	-0.013463
-2.00	1.50	-0.000546	-0.000687	-0.000942	-0.004470	-0.010125	-0.010125	-0.011156	-0.012633	-0.013463
-2.50	1.50	-0.000546	-0.000687	-0.000942	-0.004470	-0.010125	-0.010125	-0.011156	-0.012633	-0.013463
-3.00	1.50	-0.000546	-0.000687	-0.000942	-0.004470	-0.010125	-0.010125	-0.011156	-0.012633	-0.013463
-3.50	1.50	-0.000546	-0.000687	-0.000942	-0.004470	-0.010125	-0.010125	-0.011156	-0.012633	-0.013463
-4.00	1.50	-0.000546	-0.000687	-0.000942	-0.004470	-0.010125	-0.010125	-0.011156	-0.012633	-0.013463
-4.50	1.50	-0.000546	-0.000687	-0.000942	-0.004470	-0.010125	-0.010125	-0.011156	-0.012633	-0.013463
-5.00	1.50	-0.000546	-0.000687	-0.000942	-0.004470	-0.010125	-0.010125	-0.011156	-0.012633	-0.013463
-5.50	1.50	-0.000546	-0.000687	-0.000942	-0.004470	-0.010125	-0.010125	-0.011156	-0.012633	-0.013463
-6.00	1.50	-0.000546	-0.000687	-0.000942	-0.004470	-0.010125	-0.010125	-0.011156	-0.012633	-0.013463
-6.50	1.50	-0.000546	-0.000687	-0.000942	-0.004470	-0.010125	-0.010125	-0.011156	-0.012633	-0.013463
-7.00	1.50	-0.000546	-0.000687	-0.000942	-0.004470	-0.010125	-0.010125	-0.011156	-0.012633	-0.013463
-7.50	1.50	-0.000546	-0.000687	-0.000942	-0.004470	-0.010125	-0.010125	-0.011156	-0.012633	-0.013463
-8.00	1.50	-0.000546	-0.000687	-0.000942	-0.004470	-0.010125	-0.010125	-0.011156	-0.012633	-0.013463
-8.50	1.50	-0.000546	-0.000687	-0.000942	-0.004470	-0.010125	-0.010125	-0.011156	-0.012633	-0.013463
-9.00	1.50	-0.000546	-0.000687	-0.000942	-0.004470	-0.010125	-0.010125	-0.011156	-0.012633	-0.013463
-9.50	1.50	-0.000546	-0.000687	-0.000942	-0.004470	-0.010125	-0.010125	-0.011156	-0.012633	-0.013463
-10.00	1.50	-0.000546	-0.000687	-0.000942	-0.004470	-0.010125	-0.010125	-0.011156	-0.012633	-0.013463
-10.50	1.50	-0.000546	-0.000687	-0.000942	-0.004470	-0.010125	-0.010125	-0.011156	-0.012633	-0.013463
-11.00	1.50	-0.000546	-0.000687	-0.000942	-0.004470	-0.010125	-0.010125	-0.011156	-0.012633	-0.013463
-11.50	1.50	-0.000546	-0.000687	-0.000942	-0.004470	-0.010125	-0.010125	-0.011156	-0.012633	-0.013463
-12.00	1.50	-0.000546	-0.000687	-0.000942	-0.004470	-0.010125	-0.010125	-0.011156	-0.012633	-0.013463
-12.50	1.50	-0.000546	-0.000687	-0.000942	-0.004470	-0.010125	-0.010125	-0.011156	-0.012633	-0.013463
-13.00	1.50	-0.000546	-0.000687	-0.000942	-0.004470	-0.010125	-0.010125	-0.011156	-0.012633	-0.013463
-13.50	1.50	-0.000546	-0.000687	-0.000942	-0.004470	-0.010125	-0.010125	-0.011156	-0.012633	-0.013463
-14.00	1.50	-0.000546	-0.000687	-0.000942	-0.004470	-0.010125	-0.010125	-0.011156	-0.012633	-0.013463
-14.50	1.50	-0.000546	-0.000687	-0.000942	-0.004470	-0.010125	-0.010125	-0.011156	-0.012633	-0.013463
-15.00	1.50	-0.000546	-0.000687	-0.000942	-0.004470	-0.010125	-0.010125	-0.011156	-0.012633	-0.013463
-15.50	1.50	-0.000546	-0.000687	-0.000942	-0.004470	-0.010125	-0.010125	-0.011156	-0.012633	-0.013463
-16.00	1.50	-0.000546	-0.000687	-0.000942	-0.004470	-0.010125	-0.010125	-0.011156	-0.012633	-0.013463
-16.50	1.50	-0.000546	-0.000687	-0.000942	-0.004470	-0.010125	-0.010125	-0.011156	-0.012633	-0.013463
-17.00	1.50	-0.000546	-0.000687	-0.000942	-0.004470	-0.010125	-0.010125	-0.011156	-0.012633	-0.013463
-17.50	1.50	-0.000546	-0.000687	-0.000942	-0.004470	-0.010125	-0.010125	-0.011156	-0.012633	-0.013463
-18.00	1.50	-0.000546	-0.000687	-0.000942	-0.004470	-0.010125	-0.010125	-0.011156	-0.012633	-0.013463
-18.50	1.50	-0.000546	-0.000687	-0.000942	-0.004470	-0.010125	-0.010125	-0.011156	-0.012633	-0.013463
-19.00	1.50	-0.000546	-0.000687	-0.000942	-0.004470	-0.010125	-0.010125	-0.011156	-0.012633	-0.013463
-19.50	1.50	-0.000546	-0.000687	-0.000942						

Point	1	2	3	4	5	6	7	8	9	10
h/Da =	35.17	17.73	11.82	8.85	5.90	4.71	3.53	2.33	1.16	1.74
Total Thrust =	53.54	53.12	52.99	52.95	53.36	53.07	53.02	53.02	53.05	53.02
NPR Front =	2.14	2.14	2.13	2.13	2.13	2.14	2.13	2.13	2.13	2.13
NPR Aft =	2.15	2.13	2.13	2.13	2.13	2.14	2.13	2.13	2.13	2.13
X-loc	ACP	ACP	ACP	ACP	ACP	ACP	ACP	ACP	ACP	ACP
Y-loc	ACP	ACP	ACP	ACP	ACP	ACP	ACP	ACP	ACP	ACP
2.00	-0.000614	-0.000917	-0.000049	0.001653	0.001416	0.001436	-0.001645	-0.008935	-0.021496	-0.015821
0.50	-0.000614	-0.000917	-0.000049	0.001653	0.001416	0.001436	-0.001645	-0.008935	-0.021496	-0.015821
-2.00	-0.000977	-0.000463	-0.000684	0.001976	0.005062	0.00742	0.011428	0.015768	0.023349	0.019041
-3.50	-0.000438	-0.000444	-0.000694	0.000675	0.001030	0.00241	0.001810	-0.001983	-0.011231	-0.008758
-4.50	-0.000481	-0.000783	-0.000955	-0.001232	-0.002172	-0.00414	-0.006837	-0.011266	-0.021870	-0.016663
-6.00	-0.000637	-0.000679	-0.000922	-0.001304	-0.002537	-0.005148	-0.007856	-0.010632	-0.013009	-0.012433
-7.50	-0.000838	-0.000650	-0.000905	-0.000984	-0.002662	-0.005078	-0.005372	-0.006223	-0.006953	-0.006796

Force and Moment Summary

Balance h/Da =	35.17	17.73	11.82	8.85	5.90	4.71	3.53	2.33	1.16	1.74
Pressure AL/TA =	-0.016	-0.018	-0.017	-0.015	-0.023	-0.036	-0.067	-0.124	-0.244	-0.182
Pressure AM/TA =	0.013	0.021	0.018	0.018	0.028	0.035	0.062	0.111	0.206	0.151
Pressure AH/TA =	0.005	0.004	0.015	0.018	0.006	0.018	0.034	0.021	0.033	0.032
Pressure AM/TA =	0.005	0.002	0.018	0.026	0.023	0.024	0.028	0.033	0.097	0.054

Configuration: 2R-12-0-16/8 Jet-Induced Pressure Increments Run 252

Point	1	2	3	4	5	6	7	8
h/D <sub>e</sub> =	33.98	17.72	11.79	8.84	5.89	4.71	3.51	2.32
Total Thrust =	136.19	136.90	137.00	136.94	136.93	136.94	136.98	137.02
NPR Front =	4.13	4.15	4.15	4.15	4.15	4.15	4.15	4.15
NPR Aft =	4.14	4.16	4.16	4.16	4.17	4.17	4.17	4.17
X-loc	ACP	ACP	ACP	ACP	ACP	ACP	ACP	ACP
Y-loc	ACP	ACP	ACP	ACP	ACP	ACP	ACP	ACP

Point	1	2	3	4	5	6	7	8
h/D <sub>e</sub> =	33.98	17.72	11.79	8.84	5.89	4.71	3.51	2.32
Total Thrust =	136.19	136.90	137.00	136.94	136.93	136.94	136.98	137.02
NPR Front =	4.13	4.15	4.15	4.15	4.15	4.15	4.15	4.15
NPR Aft =	4.14	4.16	4.16	4.16	4.17	4.17	4.17	4.17
X-loc	ACP	ACP	ACP	ACP	ACP	ACP	ACP	ACP
Y-loc	ACP	ACP	ACP	ACP	ACP	ACP	ACP	ACP

Point	1	2	3	4	5	6	7	8
h/D <sub>e</sub> =	33.98	17.72	11.79	8.84	5.89	4.71	3.51	2.32
Total Thrust =	136.19	136.90	137.00	136.94	136.93	136.94	136.98	137.02
NPR Front =	4.13	4.15	4.15	4.15	4.15	4.15	4.15	4.15
NPR Aft =	4.14	4.16	4.16	4.16	4.17	4.17	4.17	4.17
X-loc	ACP	ACP	ACP	ACP	ACP	ACP	ACP	ACP
Y-loc	ACP	ACP	ACP	ACP	ACP	ACP	ACP	ACP

Point	1	2	3	4	5	6	7	8
h/D <sub>e</sub> =	33.98	17.72	11.79	8.84	5.89	4.71	3.51	2.32
Total Thrust =	136.19	136.90	137.00	136.94	136.93	136.94	136.98	137.02
NPR Front =	4.13	4.15	4.15	4.15	4.15	4.15	4.15	4.15
NPR Aft =	4.14	4.16	4.16	4.16	4.17	4.17	4.17	4.17
X-loc	ACP	ACP	ACP	ACP	ACP	ACP	ACP	ACP
Y-loc	ACP	ACP	ACP	ACP	ACP	ACP	ACP	ACP

Force and Moment Summary  
 h/D<sub>e</sub> = 33.98  
 Balance AL/T = -0.012  
 Pressure AL/T = -0.014  
 Balance AM/TDe = 0.005  
 Pressure AM/TDe = 0.001

Configuration: 2R-12-0-16/8  
 Jet-Induced Pressure Increments  
 Run 253

Point	1	2	3	4
h/De =	2.35	3.52	4.71	5.89
Total Throat =	220.35	219.04	218.99	218.91
NPR Front =	6.17	6.14	6.14	6.14
NPR Aft =	6.19	6.16	6.15	6.15
X-loc	ACP	ACP	ACP	ACP
Y-loc	ACP	ACP	ACP	ACP
7.50	0.00	-0.002523	-0.003212	-0.002559
7.00	0.00	-0.003154	-0.003762	-0.003177
6.50	0.00	-0.002720	-0.003304	-0.002903
6.00	0.00	-0.002141	-0.002857	-0.002515
5.50	0.00	-0.001411	-0.002041	-0.001858
5.00	0.00	-0.000730	-0.001300	-0.000822
4.50	0.00	-0.000678	-0.000847	-0.000902
4.00	0.00	-0.000819	-0.003062	-0.004223
3.50	0.00	-0.002288	-0.002629	-0.001994
3.00	0.00	0.004762	0.009105	0.004800
2.50	0.00	0.008431	0.012841	0.005082
2.00	0.00	0.007190	0.010326	0.004701
1.50	0.00	-0.000448	-0.003996	-0.001600
1.00	0.00	-0.005930	-0.001931	-0.001061
0.50	0.00	-0.009788	-0.005497	-0.003130
0.00	0.00	-0.010816	-0.007087	-0.003942
-0.50	0.00	-0.008125	-0.005199	-0.003210
-1.00	0.00	-0.003557	-0.000926	-0.000745
-1.50	0.00	-0.001139	0.003206	0.001396
-2.00	0.00	-0.002450	-0.002472	-0.002102
-2.50	0.00	-0.002755	-0.002981	-0.002479
-3.00	0.00	-0.002583	-0.002429	-0.001662
-3.50	0.75	-0.002951	-0.003517	-0.003272
-4.00	0.75	-0.004356	-0.005718	-0.006383
-4.50	0.75	-0.006434	-0.007261	-0.011011
-5.00	0.75	-0.003318	-0.002217	-0.002166
-5.50	0.75	-0.005146	-0.002934	-0.001446
-6.00	0.75	-0.009081	-0.005414	-0.002805
-6.50	0.75	-0.008551	-0.006239	-0.003789
-7.00	0.75	-0.005416	-0.003671	-0.002716
-7.50	0.75	-0.004114	-0.004147	-0.003402
-8.00	0.75	-0.007818	-0.006928	-0.007374
-8.50	0.75	-0.003594	-0.003861	-0.003787
-9.00	1.13	-0.002658	-0.002717	-0.001991
-9.50	1.13	-0.013967	-0.018326	-0.016954
-10.00	1.13	-0.012110	-0.013970	-0.013281
-10.50	1.50	-0.003045	-0.003803	-0.002844
-11.00	1.50	-0.004630	-0.004991	-0.004004
-11.50	1.50	-0.005187	-0.005873	-0.007102
-12.00	1.50	-0.009483	-0.009652	-0.010856
-12.50	1.50	-0.008060	-0.009681	-0.007201
-13.00	1.50	-0.008404	-0.007968	-0.005048
-13.50	1.50	-0.010230	-0.006226	-0.002901
-14.00	1.50	-0.010230	-0.006226	-0.002901
-14.50	1.50	0.008721	0.010901	0.005562
-15.00	1.50	0.008009	0.008874	0.002735
-15.50	1.50	-0.006065	-0.002376	-0.000926
-16.00	1.50	-0.010291	-0.007142	-0.004259
-16.50	1.50	-0.009587	-0.007920	-0.004591
-17.00	1.50	-0.008019	-0.007490	-0.004955
-17.50	1.50	-0.007542	-0.008093	-0.005524
-18.00	1.50	-0.006843	-0.008373	-0.006915
-18.50	1.50	-0.006225	-0.006299	-0.005145
-19.00	1.50	-0.003762	-0.004841	-0.002856
-19.50	1.50	-0.002542	-0.002870	-0.001976
-20.00	3.00	-0.002834	-0.002680	-0.002290
-20.50	3.00	-0.005027	-0.004598	-0.003748
-21.00	3.00	-0.007882	-0.006367	-0.003785
-21.50	3.00	0.008721	0.010901	0.005562
-22.00	3.50	0.008721	0.010901	0.005562

Force and Moment Summary  
 Balance h/De = 2.35 3.52 4.71 5.89  
 Pressure AL/T = -0.097 -0.061 -0.042 -0.029  
 Balance AL/T = -0.098 -0.056 -0.047 -0.029  
 Pressure AH/TDe = 0.020 0.015 0.009 0.016  
 Pressure AH/TDe = 0.024 0.024 0.010 0.011

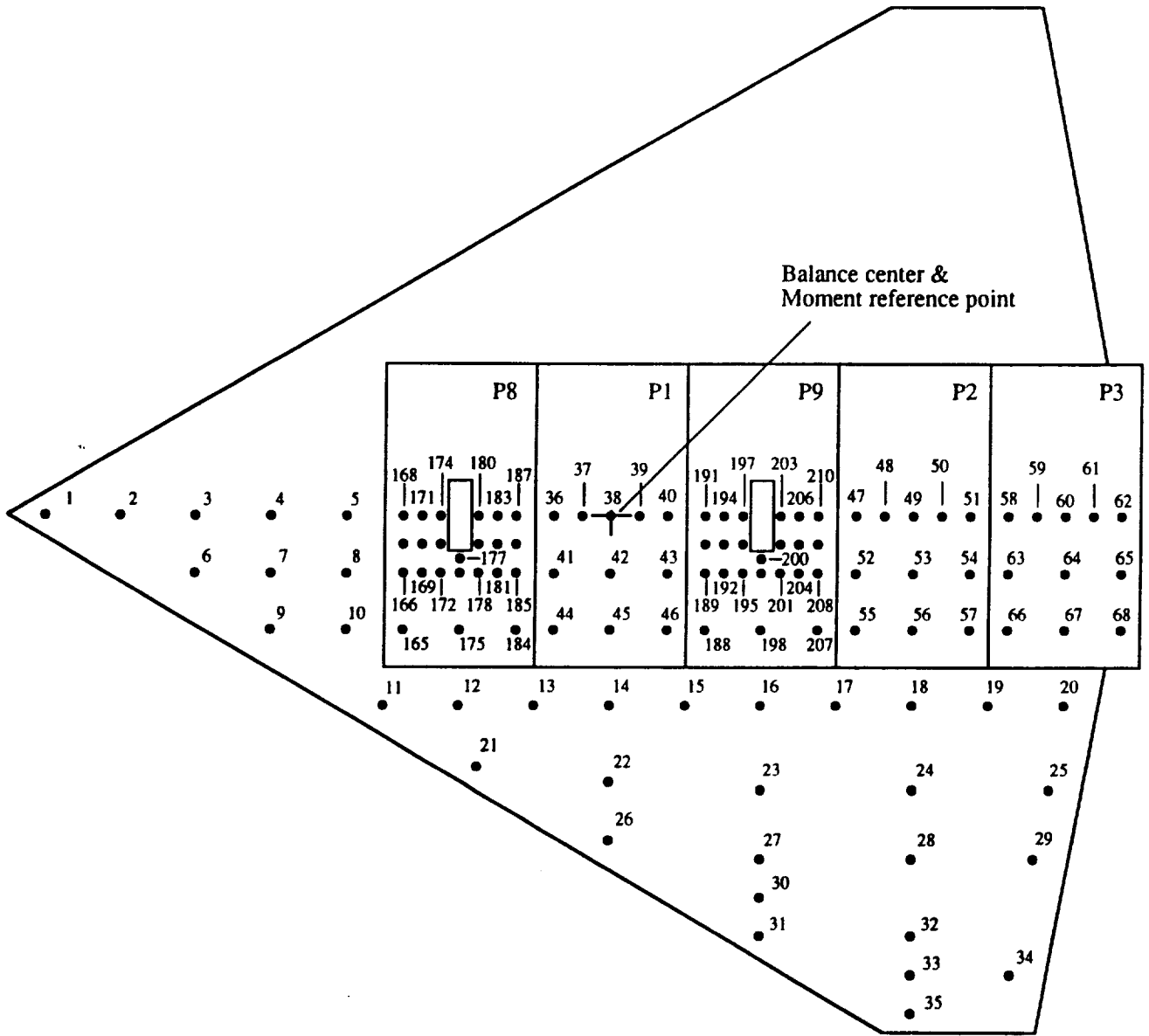

Figure 71. Configuration 2R\_8\_0\_DW;  $D_e = 1.695$  in.,  $A_{jet} = 2.26$  in.<sup>2</sup>.

Pressure Orifice Locations and Weighting Factors

Conf. # 2R\_8\_0\_DW

Distance from balance center to moment reference point,  $X_0 = 0$

Orif. #	Mom. arm	Sta. y	$\Delta$ .Area	Sta. x
1	14.6	0	2.3	15
2	12.86	0	6.918	13
3	11	0	3	11
4	9	0	3	9
5	7	0	3	7
6	10.9	1.5	8.546	11
7	9	1.5	6	9
8	7	1.5	6	7
9	8.87	3	7.166	9
10	7	3	7	7
11	6.14	5	8.91	6
12	4	5	8	4
13	2	5	8	2
14	0	5	8	0
15	-2	5	8	-2
16	-4	5	8	-4
17	-6	5	8	-6
18	-8	5	8	-8
19	-10	5	8	-10
20	-11.91	5	8.06	-12
21	3.06	6.6	7.302	3.5
22	0	7	16	0
23	-4	7	16	-4
24	-8	7	16	-8
25	-11.31	7	10.484	-11.6
26	-0.765	8.5	9.904	0
27	-4	9	12	-4
28	-8	9	16	-8
29	-11.11	9	8.908	-11.2
30	-4	10	8	-4
31	-4.84	11	8.376	-4
32	-8	11	12	-8
33	-8	12	8	-8
34	-10.86	12	12.005	-10.6
35	-8.17	13	6.883	-8
165	5.5	3	5.313	5.5
166	5.5	1.5	1.125	5.5
167	5.5	0.75	1.125	5.5
168	5.5	0	0.563	5.5
169	5	1.5	0.75	5
170	5	0.75	0.75	5
171	5	0	0.375	5
172	4.5	1.5	0.625	4.5
173	4.5	0.75	0.578	4.5
174	4.5	0	0.295	4.5
175	4	3	6.375	4

Conf. # 2R\_8\_0\_DW, continued

Orif. #	Mom. arm	Sta. y	Δ.Area	Sta. x
176	4	1.5	0.625	4
177	4	1.125	0.62	4
178	3.5	1.5	0.625	3.5
179	3.5	0.75	0.578	3.5
180	3.5	0	0.295	3.5
181	3	1.5	0.75	3
182	3	0.75	0.75	3
183	3	0	0.375	3
184	2.5	3	5.313	2.5
185	2.5	1.5	1.125	2.5
186	2.5	0.75	1.125	2.5
187	2.5	0	0.563	2.5
36	1.5	0	1.313	1.5
37	0.75	0	1.125	0.75
38	0	0	1.125	0
39	-0.75	0	1.125	-0.75
40	-1.5	0	1.313	-1.5
41	1.5	1.5	3.75	1.5
42	0	1.5	4.5	0
43	-1.5	1.5	3.75	-1.5
44	1.5	3	4.375	1.5
45	0	3	5.25	0
46	-1.5	3	4.375	-1.5
188	-2.5	3	5.313	-2.5
189	-2.5	1.5	1.125	-2.5
190	-2.5	0.75	1.125	-2.5
191	-2.5	0	0.563	-2.5
192	-3	1.5	0.75	-3
193	-3	0.75	0.75	-3
194	-3	0	0.375	-3
195	-3.5	1.5	0.625	-3.5
196	-3.5	0.75	0.578	-3.5
197	-3.5	0	0.295	-3.5
198	-4	3	6.375	-4
199	-4	1.5	0.625	-4
200	-4	1.125	0.62	-4
201	-4.5	1.5	0.625	-4.5
202	-4.5	0.75	0.578	-4.5
203	-4.5	0	0.295	-4.5
204	-5	1.5	0.75	-5
205	-5	0.75	0.75	-5
206	-5	0	0.375	-5
207	-5.5	3	5.313	-5.5
208	-5.5	1.5	1.125	-5.5
209	-5.5	0.75	1.125	-5.5
210	-5.5	0	0.563	-5.5
47	-6.5	0	1.313	-6.5
48	-7.25	0	1.125	-7.25
49	-8	0	1.125	-8
50	-8.75	0	1.125	-8.75
51	-9.5	0	1.313	-9.5



Conf. # 2R\_8\_0\_DW, continued

Orif. #	Mom. arm	Sta. y	$\Delta$ .Area	Sta. x
52	-6.5	1.5	3.75	-6.5
53	-8	1.5	4.5	-8
54	-9.5	1.5	3.75	-9.5
55	-6.5	3	4.375	-6.5
56	-8	3	5.25	-8
57	-9.5	3	4.375	-9.5
58	-10.5	0	1.313	-10.5
59	-11.25	0	1.125	-11.25
60	-12	0	1.125	-12
61	-12.75	0	1.125	-12.75
62	-13.5	0	1.313	-13.5
63	-10.5	1.5	3.75	-10.5
64	-12	1.5	4.5	-12
65	-13.5	1.5	3.75	-13.5
66	-10.5	3	4.375	-10.5
67	-12	3	5.25	-12
68	-13.5	3	4.375	-13.5



Configuration: 2R-8-0-DM  
Run 255

Point	1	2	3	4	5	6
h/De =	11.83	8.86	5.91	4.72	3.52	2.33
Total Thrust =	137.01	136.65	136.95	137.01	137.05	136.97
NPR Front =	4.18	4.17	4.17	4.17	4.18	4.17
NPR Aft =	4.24	4.23	4.24	4.24	4.24	4.24
X-loc	ACP	ACP	ACP	ACP	ACP	ACP
Y-loc	ACP	ACP	ACP	ACP	ACP	ACP
15.00	-0.00340	-0.00331	-0.00725	-0.00770	-0.00995	-0.001146
13.00	-0.00285	-0.00296	-0.00659	-0.00762	-0.00940	-0.001260
11.00	-0.00212	-0.00314	-0.00738	-0.00879	-0.00948	-0.001533
9.00	-0.00272	-0.00318	-0.00932	-0.01125	-0.01447	-0.002241
7.00	-0.00419	-0.00592	-0.01982	-0.02193	-0.02177	-0.002847
5.00	-0.00708	-0.00628	-0.02059	-0.023849	-0.02546	-0.002896
3.50	-0.00798	-0.00750	-0.02676	-0.02946	-0.02924	-0.002650
3.00	-0.00960	-0.00872	-0.03769	-0.04437	-0.005884	-0.008789
2.50	-0.00956	-0.00831	-0.00959	-0.01470	-0.00249	-0.003906
1.50	-0.00514	-0.00525	-0.03190	-0.02718	-0.02572	-0.003023
0.75	-0.000183	-0.000550	-0.004288	-0.006084	-0.010577	-0.019166
0.00	-0.00115	-0.00476	-0.004717	-0.01041	-0.013557	-0.010974
-1.50	-0.00242	-0.00445	-0.002719	-0.007589	-0.007318	-0.007828
-2.50	-0.00316	-0.00399	-0.001756	-0.004358	-0.005509	-0.015270
-3.00	-0.00228	-0.00551	-0.002295	-0.004381	-0.005509	-0.003246
-3.50	-0.00751	-0.00797	-0.004421	-0.009083	-0.012030	-0.009652
-4.50	-0.00697	-0.01115	-0.002811	-0.004823	-0.007080	-0.008135
-5.00	-0.00466	-0.00874	-0.002806	-0.004595	-0.006698	-0.009130
-5.50	-0.00587	-0.00755	-0.002776	-0.003597	-0.005562	-0.007882
-6.50	-0.00414	-0.00527	-0.01781	-0.02606	-0.03074	-0.004890
-8.00	-0.00376	-0.00716	-0.01696	-0.01886	-0.02653	-0.004682
-9.50	-0.00336	-0.00639	-0.01534	-0.01886	-0.02506	-0.003576
-10.50	-0.00414	-0.00750	-0.01723	-0.01771	-0.02245	-0.002193
-11.25	-0.00518	-0.00750	-0.01585	-0.01487	-0.01916	-0.001681
-12.00	-0.00363	-0.00606	-0.01473	-0.01512	-0.00905	-0.000942
-13.50	-0.00289	-0.00534	-0.01471	-0.01669	-0.01022	-0.000715
5.00	-0.00623	-0.00793	-0.02358	-0.02467	-0.02467	-0.002984
4.50	-0.01194	-0.01547	-0.0138	-0.00548	-0.005684	-0.004558
3.50	-0.00620	-0.00584	-0.01208	-0.02225	-0.03485	-0.008899
3.00	-0.00419	-0.00586	-0.00281	-0.01586	-0.001485	-0.001532
2.50	-0.00382	-0.00418	-0.01177	-0.01431	-0.001151	-0.000608
2.00	-0.00296	-0.00233	-0.00440	-0.00417	-0.000804	-0.000431
1.50	-0.00430	-0.01183	-0.01047	-0.01794	-0.017891	-0.018073
1.00	-0.00493	-0.00826	-0.003423	-0.006512	-0.009740	-0.009502
0.75	-0.00178	-0.00100	-0.009755	-0.016190	-0.005852	-0.008590
0.50	-0.001299	-0.00198	-0.01370	-0.030580	-0.04075	-0.025577
0.25	-0.00370	-0.00350	-0.00817	-0.000883	-0.001211	-0.002928
0.00	-0.00312	-0.00369	-0.001495	-0.01568	-0.001941	-0.002915
1.50	-0.00310	-0.00358	-0.01112	-0.000888	-0.001173	-0.003159
2.00	-0.00419	-0.00501	-0.01807	-0.02240	-0.02534	-0.002557
2.50	-0.00686	-0.00707	-0.02700	-0.03506	-0.03439	-0.003255
3.00	-0.00846	-0.00898	-0.03344	-0.04655	-0.04387	-0.005599
3.50	-0.01000	-0.01437	-0.04257	-0.07760	-0.09256	-0.010540
4.00	-0.01044	-0.01615	-0.03720	-0.05807	-0.08950	-0.014351
4.50	-0.00623	-0.00467	-0.01938	-0.04931	-0.07357	-0.013774
5.00	-0.00546	-0.00610	-0.00748	-0.02968	-0.005816	-0.013518
5.50	-0.00314	-0.00565	-0.002123	-0.000480	-0.000419	-0.003315
6.00	-0.00425	-0.00459	-0.001762	-0.007299	-0.011740	-0.021680
6.50	-0.00681	-0.00530	-0.00381	-0.004905	-0.005063	-0.003892
7.00	-0.00893	-0.00650	-0.003460	-0.003588	-0.008268	-0.018228
7.50	-0.011747	-0.00950	-0.005087	-0.007901	-0.013355	-0.020754
8.00	-0.01135	-0.01378	-0.00297	-0.013131	-0.018211	-0.022402
8.50	-0.00604	-0.00983	-0.004685	-0.007391	-0.011366	-0.013205
9.00	-0.00591	-0.00824	-0.003305	-0.004921	-0.007501	-0.009048
9.50	-0.00488	-0.00659	-0.003311	-0.004842	-0.006076	-0.007865
10.00	-0.00342	-0.00553	-0.002729	-0.003949	-0.004540	-0.006125

Force and Moment Summary

h/De =	11.83	8.86	5.91	4.72	3.52	2.33
Balance	AL/T = -0.044	-0.065	-0.133	-0.177	-0.229	-0.347
Pressure	AL/T = -0.045	-0.065	-0.133	-0.167	-0.213	-0.327
Balance	AM/TDe = 0.085	0.146	0.324	0.364	0.337	0.322
Pressure	AM/TDe = 0.088	0.166	0.354	0.397	0.372	0.391







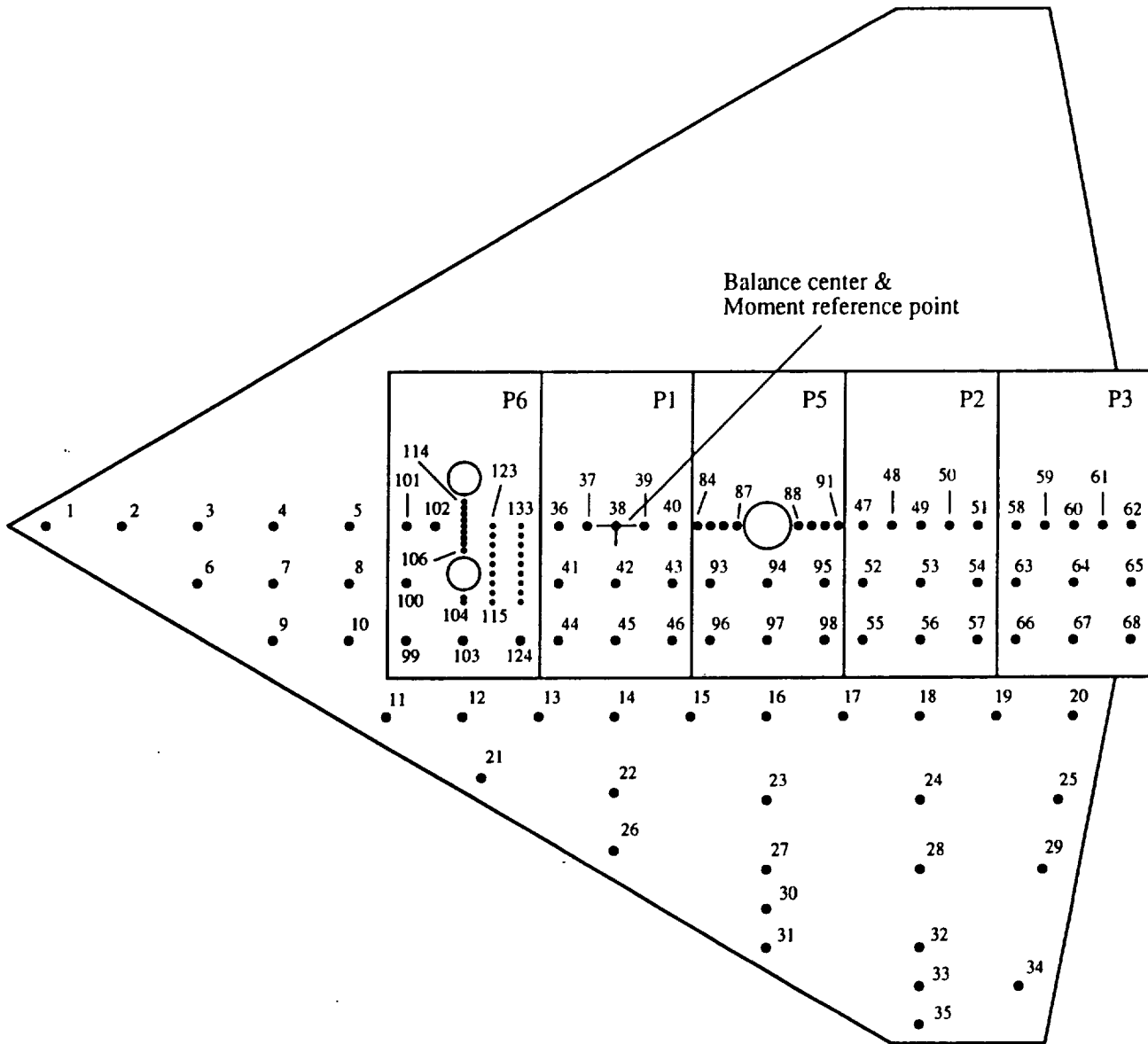

Figure 72. Configuration 3C\_8\_2.5\_DW;  $D_e = 1.699$  in.,  $A_{jet} = 2.27$  in.<sup>2</sup>.

## Pressure Orifice Locations and Weighting Factors

Conf. # 3C\_8\_2.5\_DW

Distance from balance center to moment reference point,  $X_0 = 0$

Orif. #	Mom. arm	Sta. y	$\Delta$ .Area	Sta. x
1	14.6	0	2.3	15
2	12.86	0	6.918	13
3	11	0	3	11
4	9	0	3	9
5	7	0	3	7
6	10.9	1.5	8.546	11
7	9	1.5	6	9
8	7	1.5	6	7
9	8.87	3	7.166	9
10	7	3	7	7
11	6.14	5	8.91	6
12	4	5	8	4
13	2	5	8	2
14	0	5	8	0
15	-2	5	8	-2
16	-4	5	8	-4
17	-6	5	8	-6
18	-8	5	8	-8
19	-10	5	8	-10
20	-11.91	5	8.06	-12
21	3.06	6.6	7.302	3.5
22	0	7	16	0
23	-4	7	16	-4
24	-8	7	16	-8
25	-11.31	7	10.484	-11.6
26	-0.765	8.5	9.904	0
27	-4	9	12	-4
28	-8	9	16	-8
29	-11.11	9	8.908	-11.2
30	-4	10	8	-4
31	-4.84	11	8.376	-4
32	-8	11	12	-8
33	-8	12	8	-8
34	-10.86	12	12.005	-10.6
35	-8.17	13	6.883	-8
99	5.5	3	4.688	5.5
100	5.165	1.5	4.38	5.5
101	5.5	0	1.313	5.5
102	4.75	0	1.125	4.75
103	4	3	5.625	4
104	4	2	0.278	4
105	4	1.88	0.38	4
106	4	0.64	0.38	4
107	4	0.48	0.24	4
108	4	0.32	0.24	4
109	4	0.16	0.24	4



Conf. # 3C\_8\_2.5\_DW, continued

Orif. #	Mom. arm	Sta. y	Δ.Area	Sta. x
110	4	0	0.12	4
111	4	-0.16	0	4
112	4	-0.32	0	4
113	4	-0.48	0	4
114	4	-0.64	0	4
115	3.25	2	0.375	3.25
116	3.25	1.75	0.375	3.25
117	3.25	1.5	0.355	3.25
118	3.25	1.25	0.325	3.25
119	3.25	1	0.355	3.25
120	3.25	0.75	0.375	3.25
121	3.25	0.5	0.375	3.25
122	3.25	0.25	0.375	3.25
123	3.25	0	0.188	3.25
124	2.5	3	4.688	2.5
125	2.5	2	0.438	2.5
126	2.5	1.75	0.438	2.5
127	2.5	1.5	0.438	2.5
128	2.5	1.25	0.438	2.5
129	2.5	1	0.438	2.5
130	2.5	0.75	0.438	2.5
131	2.5	0.5	0.438	2.5
132	2.5	0.25	0.438	2.5
133	2.5	0	0.219	2.5
36	1.5	0	1.313	1.5
37	0.75	0	1.125	0.75
38	0	0	1.125	0
39	-0.75	0	1.125	-0.75
40	-1.5	0	1.313	-1.5
41	1.5	1.5	3.75	1.5
42	0	1.5	4.5	0
43	-1.5	1.5	3.75	-1.5
44	1.5	3	4.375	1.5
45	0	3	5.25	0
46	-1.5	3	4.375	-1.5
84	-2.15	0	0.634	-2.15
85	-2.5	0	0.683	-2.5
86	-2.85	0	0.683	-2.85
87	-3.2	0	0.619	-3.2
88	-4.8	0	0.619	-4.8
89	-5.15	0	0.683	-5.15
90	-5.5	0	0.683	-5.5
91	-5.85	0	0.634	-5.85
93	-2.5	1.5	3.19	-2.5
94	-4	1.5	5.062	-4
95	-5.5	1.5	3.19	-5.5
96	-2.5	3	4.375	-2.5
97	-4	3	5.25	-4
98	-5.5	3	4.375	-5.5
47	-6.5	0	1.313	-6.5
48	-7.25	0	1.125	-7.25

Conf. # 3C\_8\_2.5\_DW, continued

Orif. #	Mom. arm	Sta. y	$\Delta$ .Area	Sta. x
49	-8	0	1.125	-8
50	-8.75	0	1.125	-8.75
51	-9.5	0	1.313	-9.5
52	-6.5	1.5	3.75	-6.5
53	-8	1.5	4.5	-8
54	-9.5	1.5	3.75	-9.5
55	-6.5	3	4.375	-6.5
56	-8	3	5.25	-8
57	-9.5	3	4.375	-9.5
58	-10.5	0	1.313	-10.5
59	-11.25	0	1.125	-11.25
60	-12	0	1.125	-12
61	-12.75	0	1.125	-12.75
62	-13.5	0	1.313	-13.5
63	-10.5	1.5	3.75	-10.5
64	-12	1.5	4.5	-12
65	-13.5	1.5	3.75	-13.5
66	-10.5	3	4.375	-10.5
67	-12	3	5.25	-12
68	-13.5	3	4.375	-13.5

Configuration: 3C-8-2.5-EM  
 Jet-Induced Pressure Increments  
 Run 260

Point	1	2	3	4	5	6	7	8	9	10	11	12	13	14	15	16	17	18	19	20	21	22	23	24	25	26	27	28	29	30	31	32	33	34	35	36	37	38	39	40	41	42	43	44	45	46	47	48	49	50	51	52	53	54	55	56	57	58	59	60	61	62	63	64	65	66	67	68	69	70	71	72	73	74	75	76	77	78	79	80	81	82	83	84	85	86	87	88	89	90	91	92	93	94	95	96	97	98	99	100																																																																																																																																																																																																																																																																																																																																																																																																																																																																																																																																																																																																																																																																																																																																																																																																																							
Total Thrust =	33.90	17.66	11.78	8.83	5.87	4.70	3.53	2.32	1.50	0.000203	-0.000210	-0.000395	-0.000672	-0.000486	-0.000887	-0.001257	-0.001628	-0.002000	-0.002372	-0.002744	-0.003116	-0.003488	-0.003860	-0.004232	-0.004604	-0.004976	-0.005348	-0.005720	-0.006092	-0.006464	-0.006836	-0.007208	-0.007580	-0.007952	-0.008324	-0.008696	-0.009068	-0.009440	-0.009812	-0.010184	-0.010556	-0.010928	-0.011300	-0.011672	-0.012044	-0.012416	-0.012788	-0.013160	-0.013532	-0.013904	-0.014276	-0.014648	-0.015020	-0.015392	-0.015764	-0.016136	-0.016508	-0.016880	-0.017252	-0.017624	-0.017996	-0.018368	-0.018740	-0.019112	-0.019484	-0.019856	-0.020228	-0.020600	-0.020972	-0.021344	-0.021716	-0.022088	-0.022460	-0.022832	-0.023204	-0.023576	-0.023948	-0.024320	-0.024692	-0.025064	-0.025436	-0.025808	-0.026180	-0.026552	-0.026924	-0.027296	-0.027668	-0.028040	-0.028412	-0.028784	-0.029156	-0.029528	-0.029900	-0.030272	-0.030644	-0.031016	-0.031388	-0.031760	-0.032132	-0.032504	-0.032876	-0.033248	-0.033620	-0.033992	-0.034364	-0.034736	-0.035108	-0.035480	-0.035852	-0.036224	-0.036596	-0.036968	-0.037340	-0.037712	-0.038084	-0.038456	-0.038828	-0.039200	-0.039572	-0.039944	-0.040316	-0.040688	-0.041060	-0.041432	-0.041804	-0.042176	-0.042548	-0.042920	-0.043292	-0.043664	-0.044036	-0.044408	-0.044780	-0.045152	-0.045524	-0.045896	-0.046268	-0.046640	-0.047012	-0.047384	-0.047756	-0.048128	-0.048500	-0.048872	-0.049244	-0.049616	-0.049988	-0.050360	-0.050732	-0.051104	-0.051476	-0.051848	-0.052220	-0.052592	-0.052964	-0.053336	-0.053708	-0.054080	-0.054452	-0.054824	-0.055196	-0.055568	-0.055940	-0.056312	-0.056684	-0.057056	-0.057428	-0.057800	-0.058172	-0.058544	-0.058916	-0.059288	-0.059660	-0.060032	-0.060404	-0.060776	-0.061148	-0.061520	-0.061892	-0.062264	-0.062636	-0.063008	-0.063380	-0.063752	-0.064124	-0.064496	-0.064868	-0.065240	-0.065612	-0.065984	-0.066356	-0.066728	-0.067100	-0.067472	-0.067844	-0.068216	-0.068588	-0.068960	-0.069332	-0.069704	-0.070076	-0.070448	-0.070820	-0.071192	-0.071564	-0.071936	-0.072308	-0.072680	-0.073052	-0.073424	-0.073796	-0.074168	-0.074540	-0.074912	-0.075284	-0.075656	-0.076028	-0.076400	-0.076772	-0.077144	-0.077516	-0.077888	-0.078260	-0.078632	-0.079004	-0.079376	-0.079748	-0.080120	-0.080492	-0.080864	-0.081236	-0.081608	-0.081980	-0.082352	-0.082724	-0.083096	-0.083468	-0.083840	-0.084212	-0.084584	-0.084956	-0.085328	-0.085700	-0.086072	-0.086444	-0.086816	-0.087188	-0.087560	-0.087932	-0.088304	-0.088676	-0.089048	-0.089420	-0.089792	-0.090164	-0.090536	-0.090908	-0.091280	-0.091652	-0.092024	-0.092396	-0.092768	-0.093140	-0.093512	-0.093884	-0.094256	-0.094628	-0.095000	-0.095372	-0.095744	-0.096116	-0.096488	-0.096860	-0.097232	-0.097604	-0.097976	-0.098348	-0.098720	-0.099092	-0.099464	-0.099836	-0.100208	-0.100580	-0.100952	-0.101324	-0.101696	-0.102068	-0.102440	-0.102812	-0.103184	-0.103556	-0.103928	-0.104300	-0.104672	-0.105044	-0.105416	-0.105788	-0.106160	-0.106532	-0.106904	-0.107276	-0.107648	-0.108020	-0.108392	-0.108764	-0.109136	-0.109508	-0.109880	-0.110252	-0.110624	-0.110996	-0.111368	-0.111740	-0.112112	-0.112484	-0.112856	-0.113228	-0.113600	-0.113972	-0.114344	-0.114716	-0.115088	-0.115460	-0.115832	-0.116204	-0.116576	-0.116948	-0.117320	-0.117692	-0.118064	-0.118436	-0.118808	-0.119180	-0.119552	-0.119924	-0.120296	-0.120668	-0.121040	-0.121412	-0.121784	-0.122156	-0.122528	-0.122900	-0.123272	-0.123644	-0.124016	-0.124388	-0.124760	-0.125132	-0.125504	-0.125876	-0.126248	-0.126620	-0.126992	-0.127364	-0.127736	-0.128108	-0.128480	-0.128852	-0.129224	-0.129596	-0.130000	-0.130404	-0.130808	-0.131212	-0.131616	-0.132020	-0.132424	-0.132828	-0.133232	-0.133636	-0.134040	-0.134444	-0.134848	-0.135252	-0.135656	-0.136060	-0.136464	-0.136868	-0.137272	-0.137676	-0.138080	-0.138484	-0.138888	-0.139292	-0.139696	-0.140100	-0.140504	-0.140908	-0.141312	-0.141716	-0.142120	-0.142524	-0.142928	-0.143332	-0.143736	-0.144140	-0.144544	-0.144948	-0.145352	-0.145756	-0.146160	-0.146564	-0.146968	-0.147372	-0.147776	-0.148180	-0.148584	-0.148988	-0.149392	-0.149796	-0.150200	-0.150604	-0.151008	-0.151412	-0.151816	-0.152220	-0.152624	-0.153028	-0.153432	-0.153836	-0.154240	-0.154644	-0.155048	-0.155452	-0.155856	-0.156260	-0.156664	-0.157068	-0.157472	-0.157876	-0.158280	-0.158684	-0.159088	-0.159492	-0.159896	-0.160300	-0.160704	-0.161108	-0.161512	-0.161916	-0.162320	-0.162724	-0.163128	-0.163532	-0.163936	-0.164340	-0.164744	-0.165148	-0.165552	-0.165956	-0.166360	-0.166764	-0.167168	-0.167572	-0.167976	-0.168380	-0.168784	-0.169188	-0.169592	-0.170000	-0.170404	-0.170808	-0.171212	-0.171616	-0.172020	-0.172424	-0.172828	-0.173232	-0.173636	-0.174040	-0.174444	-0.174848	-0.175252	-0.175656	-0.176060	-0.176464	-0.176868	-0.177272	-0.177676	-0.178080	-0.178484	-0.178888	-0.179292	-0.179696	-0.180100	-0.180504	-0.180908	-0.181312	-0.181716	-0.182120	-0.182524	-0.182928	-0.183332	-0.183736	-0.184140	-0.184544	-0.184948	-0.185352	-0.185756	-0.186160	-0.186564	-0.186968	-0.187372	-0.187776	-0.188180	-0.188584	-0.188988	-0.189392	-0.189796	-0.190200	-0.190604	-0.191008	-0.191412	-0.191816	-0.192220	-0.192624	-0.193028	-0.193432	-0.193836	-0.194240	-0.194644	-0.195048	-0.195452	-0.195856	-0.196260	-0.196664	-0.197068	-0.197472	-0.197876	-0.198280	-0.198684	-0.199088	-0.199492	-0.199896	-0.200300	-0.200704	-0.201108	-0.201512	-0.201916	-0.202320	-0.202724	-0.203128	-0.203532	-0.203936	-0.204340	-0.204744	-0.205148	-0.205552	-0.205956	-0.206360	-0.206764	-0.207168	-0.207572	-0.207976	-0.208380	-0.208784	-0.209188	-0.209592	-0.210000	-0.210404	-0.210808	-0.211212	-0.211616	-0.212020	-0.212424	-0.212828	-0.213232	-0.213636	-0.214040	-0.214444	-0.214848	-0.215252	-0.215656	-0.216060	-0.216464	-0.216868	-0.217272	-0.217676	-0.218080	-0.218484	-0.218888	-0.219292	-0.219696	-0.220100	-0.220504	-0.220908	-0.221312	-0.221716	-0.222120	-0.222524	-0.222928	-0.223332	-0.223736	-0.224140	-0.224544	-0.224948	-0.225352	-0.225756	-0.226160	-0.226564	-0.226968	-0.227372	-0.227776	-0.228180	-0.228584	-0.228988	-0.229392	-0.229796	-0.230200	-0.230604	-0.231008	-0.231412	-0.231816	-0.232220	-0.232624	-0.233028	-0.233432	-0.233836	-0.234240	-0.234644	-0.235048	-0.235452	-0.235856	-0.236260	-0.236664	-0.237068	-0.237472	-0.237876	-0.238280	-0.238684	-0.239088	-0.239492	-0.239896	-0.240300	-0.240704	-0.241108	-0.241512	-0.241916	-0.242320	-0.242724	-0.243128	-0.243532	-0.243936	-0.244340	-0.244744	-0.245148	-0.245552	-0.245956	-0.246360	-0.246764	-0.247168	-0.247572	-0.247976	-0.248380	-0.248784	-0.249188	-0.249592	-0.250000	-0.250404	-0.250808	-0.251212	-0.251616	-0.252020	-0.252424	-0.252828	-0.253232	-0.253636	-0.254040	-0.254444	-0.254848	-0.255252	-0.255656	-0.256060	-0.256464	-0.256868	-0.257272	-0.257676	-0.258080	-0.258484	-0.258888	-0.259292	-0.259696	-0.260100	-0.260504	-0.260908	-0.261312	-0.261716	-0.262120	-0.262524	-0.262928	-0.263332	-0.263736	-0.264140	-0.264544	-0.264948	-0.265352	-0.265756	-0.266160	-0.266564	-0.266968	-0.267372	-0.267776	-0.268180	-0.268584	-0.268988	-0.269392	-0.269796	-0.270200	-0.270604	-0.271008	-0.271412	-0.271816	-0.272220	-0.272624	-0.273028	-0.273432	-0.273836	-0.274240	-0.274644	-0.275048	-0.275452	-0.275856	-0.276260	-0.276664	-0.277068	-0.277472	-0.277876	-0.278280	-0.278684	-0.279088	-0.279492	-0.279896	-0.280300	-0.280704	-0.281108	-0.281512	-0.281916	-0.282320	-0.282724	-0.283128	-0.283532	-0.283936	-0.284340	-0.284744	-0.285148	-0.285552	-0.285956	-0.286360	-0.286764	-0.287168	-0.287572	-0.287976	-0.288380	-0.288784	-0.289188	-0.289592	-0.290000	-0.290404	-0.290808	-0.291212	-0.291616	-0.292020	-0.292424	-0.292828	-0.293232	-0.293636	-0.294040	-0.294444	-0.294848	-0.295252	-0.295656	-0.296060	-0.296464	-0.296868	-0.297272	-0.297676	-0.298080	-0.298484	-0.298888	-0.299292	-0.299696	-0.300100	-0.300504	-0.300908	-0.301312	-0.301716	-0.302120	-0.302524	-0.302928	-0.303332	-0.303736	-0.304140	-0.304544	-0.304948	-0.305352	-0.305756	-0.306160	-0.306564	-0.306968	-0.307372	-0.307776	-0.308180	-0.308584	-0.308988	-0.309392	-0.309796	-0.310200	-0.310604	-0.311008	-0.311412	-0.311816	-0.312220	-0.312624	-0.313028	-0.313432	-0.313836	-0.314240	-0.314644	-0.315048	-0.315452	-0.315856	-0.316260	-0.316664	-0.317068	-0.317472	-0.317876	-0.318280	-0.318684	-0.319088	-0.319492	-0.319896	-0.320300	-0.320704	-0.321108	-0.321512	-0.321916	-0.322320	-0.322724	-0.323128	-0.323532	-0.323936	-0.324340	-0.324744	-0.325148	-0.325552	-0.325956	-0.326360	-0.326764	-0.327168	-0.327572	-0.327976	-0.328380	-0.328784	-0.329188	-0.329592	-0.330000	-0.330404	-0.330808	-0.331212	-0.331616	-0.332020	-0.332424	-0.332828	-0.333232	-0.333636	-0.334040	-0.334444	-0.334848	-0.335252	-0.335656	-0.336060	-0.336464	-0.336868	-0.337272	-0.337676	-0.338080	-0.338484	-0.338888	-0.339292	-0.339696	-0.340100	-0.340504	-0.340908	-0.341312	-0.341716	-0.342120	-0.342524	-0.342928	-0.343332	-0.343736

Configuration: 3C-8-2.5-DM Jet-Induced Pressure Increments Run 261

Point	1	2	3	4	5	6	7	8
h/De =	33.91	17.65	11.77	8.83	5.87	4.73	3.53	2.33
Total Thrust =	135.96	135.75	135.64	135.61	135.45	135.43	135.43	135.36
NPR Front =	4.11	4.10	4.10	4.10	4.10	4.10	4.10	4.10
NPR Aft =	4.04	4.04	4.04	4.04	4.04	4.03	4.03	4.03
Y-loc	ACP	ACP	ACP	ACP	ACP	ACP	ACP	ACP
X-loc	-12.00	-13.50	3.25	4.00	4.00	4.00	4.00	4.00
1.50	-0.00180	-0.00238	-0.00360	-0.00466	-0.00597	-0.00766	-0.01031	-0.01531
1.75	-0.00084	-0.00190	-0.00329	-0.00499	-0.00705	-0.00987	-0.01444	-0.02312
2.00	-0.00066	-0.00150	-0.00281	-0.00438	-0.00634	-0.00907	-0.01389	-0.02270
2.25	-0.00047	-0.00116	-0.00228	-0.00376	-0.00559	-0.00818	-0.01277	-0.02071
2.50	-0.00030	-0.00081	-0.00166	-0.00282	-0.00438	-0.00674	-0.01047	-0.01711
2.75	-0.00016	-0.00044	-0.00091	-0.00166	-0.00276	-0.00444	-0.00707	-0.01129
3.00	-0.00004	-0.00022	-0.00048	-0.00091	-0.00159	-0.00266	-0.00454	-0.00758
3.25	0.00000	-0.00011	-0.00026	-0.00054	-0.00103	-0.00177	-0.00297	-0.00487
3.50	0.00000	0.00000	-0.00011	-0.00026	-0.00054	-0.00103	-0.00177	-0.00297
3.75	0.00000	0.00000	0.00000	-0.00011	-0.00026	-0.00054	-0.00103	-0.00177
4.00	0.00000	0.00000	0.00000	0.00000	-0.00011	-0.00026	-0.00054	-0.00103
4.25	0.00000	0.00000	0.00000	0.00000	0.00000	-0.00011	-0.00026	-0.00054
4.50	0.00000	0.00000	0.00000	0.00000	0.00000	0.00000	-0.00011	-0.00026
4.75	0.00000	0.00000	0.00000	0.00000	0.00000	0.00000	0.00000	-0.00011
5.00	0.00000	0.00000	0.00000	0.00000	0.00000	0.00000	0.00000	0.00000
5.25	0.00000	0.00000	0.00000	0.00000	0.00000	0.00000	0.00000	0.00000
5.50	0.00000	0.00000	0.00000	0.00000	0.00000	0.00000	0.00000	0.00000
5.75	0.00000	0.00000	0.00000	0.00000	0.00000	0.00000	0.00000	0.00000
6.00	0.00000	0.00000	0.00000	0.00000	0.00000	0.00000	0.00000	0.00000
6.25	0.00000	0.00000	0.00000	0.00000	0.00000	0.00000	0.00000	0.00000
6.50	0.00000	0.00000	0.00000	0.00000	0.00000	0.00000	0.00000	0.00000
6.75	0.00000	0.00000	0.00000	0.00000	0.00000	0.00000	0.00000	0.00000
7.00	0.00000	0.00000	0.00000	0.00000	0.00000	0.00000	0.00000	0.00000
7.25	0.00000	0.00000	0.00000	0.00000	0.00000	0.00000	0.00000	0.00000
7.50	0.00000	0.00000	0.00000	0.00000	0.00000	0.00000	0.00000	0.00000
7.75	0.00000	0.00000	0.00000	0.00000	0.00000	0.00000	0.00000	0.00000
8.00	0.00000	0.00000	0.00000	0.00000	0.00000	0.00000	0.00000	0.00000
8.25	0.00000	0.00000	0.00000	0.00000	0.00000	0.00000	0.00000	0.00000
8.50	0.00000	0.00000	0.00000	0.00000	0.00000	0.00000	0.00000	0.00000
8.75	0.00000	0.00000	0.00000	0.00000	0.00000	0.00000	0.00000	0.00000
9.00	0.00000	0.00000	0.00000	0.00000	0.00000	0.00000	0.00000	0.00000
9.25	0.00000	0.00000	0.00000	0.00000	0.00000	0.00000	0.00000	0.00000
9.50	0.00000	0.00000	0.00000	0.00000	0.00000	0.00000	0.00000	0.00000
9.75	0.00000	0.00000	0.00000	0.00000	0.00000	0.00000	0.00000	0.00000
10.00	0.00000	0.00000	0.00000	0.00000	0.00000	0.00000	0.00000	0.00000
10.25	0.00000	0.00000	0.00000	0.00000	0.00000	0.00000	0.00000	0.00000
10.50	0.00000	0.00000	0.00000	0.00000	0.00000	0.00000	0.00000	0.00000
10.75	0.00000	0.00000	0.00000	0.00000	0.00000	0.00000	0.00000	0.00000
11.00	0.00000	0.00000	0.00000	0.00000	0.00000	0.00000	0.00000	0.00000
11.25	0.00000	0.00000	0.00000	0.00000	0.00000	0.00000	0.00000	0.00000
11.50	0.00000	0.00000	0.00000	0.00000	0.00000	0.00000	0.00000	0.00000
11.75	0.00000	0.00000	0.00000	0.00000	0.00000	0.00000	0.00000	0.00000
12.00	0.00000	0.00000	0.00000	0.00000	0.00000	0.00000	0.00000	0.00000
12.25	0.00000	0.00000	0.00000	0.00000	0.00000	0.00000	0.00000	0.00000
12.50	0.00000	0.00000	0.00000	0.00000	0.00000	0.00000	0.00000	0.00000
12.75	0.00000	0.00000	0.00000	0.00000	0.00000	0.00000	0.00000	0.00000
13.00	0.00000	0.00000	0.00000	0.00000	0.00000	0.00000	0.00000	0.00000

Force and Moment Summary  
 h/De = 33.91  
 Balance AL/T = -0.019  
 Pressure AL/T = -0.022  
 Balance DM/TDe = 0.023  
 Pressure DM/TDe = 0.035

Configuration: 3C-8-2.5-DM Run 262

Point	1	2	3	4	5	6	7
h/D =	33.90	17.68	11.79	8.82	8.51	4.70	3.51
Total Thrust =	220.90	221.60	221.45	221.50	221.42	221.45	221.30
NPR Front =	6.15	6.18	6.18	6.18	6.18	6.18	6.17
NPR Aft =	6.06	6.07	6.07	6.07	6.07	6.07	6.07
X-loc	ACP	ACP	ACP	ACP	ACP	ACP	ACP
Y-loc	1.50	1.50	1.50	1.50	1.50	1.50	1.50
Point	33.90	17.68	11.79	8.82	8.51	4.70	3.51
h/D =	220.90	221.60	221.45	221.50	221.42	221.45	221.30
Total Thrust =	6.15	6.18	6.18	6.18	6.18	6.18	6.17
NPR Front =	6.06	6.07	6.07	6.07	6.07	6.07	6.07
NPR Aft =	ACP	ACP	ACP	ACP	ACP	ACP	ACP
X-loc	1.50	1.50	1.50	1.50	1.50	1.50	1.50
Y-loc	1.50	1.50	1.50	1.50	1.50	1.50	1.50
Point	33.90	17.68	11.79	8.82	8.51	4.70	3.51
h/D =	220.90	221.60	221.45	221.50	221.42	221.45	221.30
Total Thrust =	6.15	6.18	6.18	6.18	6.18	6.18	6.17
NPR Front =	6.06	6.07	6.07	6.07	6.07	6.07	6.07
NPR Aft =	ACP	ACP	ACP	ACP	ACP	ACP	ACP
X-loc	1.50	1.50	1.50	1.50	1.50	1.50	1.50
Y-loc	1.50	1.50	1.50	1.50	1.50	1.50	1.50
Point	33.90	17.68	11.79	8.82	8.51	4.70	3.51
h/D =	220.90	221.60	221.45	221.50	221.42	221.45	221.30
Total Thrust =	6.15	6.18	6.18	6.18	6.18	6.18	6.17
NPR Front =	6.06	6.07	6.07	6.07	6.07	6.07	6.07
NPR Aft =	ACP	ACP	ACP	ACP	ACP	ACP	ACP
X-loc	1.50	1.50	1.50	1.50	1.50	1.50	1.50
Y-loc	1.50	1.50	1.50	1.50	1.50	1.50	1.50

Force and Moment Summary  
 Balance AL/T = 33.90  
 Pressure AL/T = -0.17  
 Balance AH/T = -0.16  
 Pressure AH/T = 0.03  
 Balance AM/IDe = 0.019  
 Pressure AM/IDe = 0.038

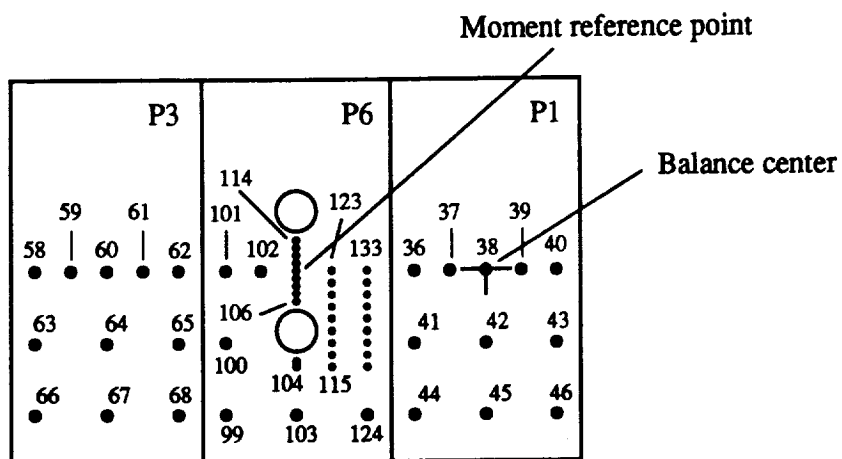

Figure 73. Configuration 2C\_0\_2.5\_12/8;  $D_e = 1.202 \text{ in.}$ ,  $A_{jet} = 1.13 \text{ in.}^2$ .

Pressure Orifice Locations and Weighting Factors

Conf. # 2C\_0\_2.5\_12/8

Distance from balance center to moment reference point,  $X_0 = 4$

Orif. #	Mom. arm	Sta. y	$\Delta$ .Area	Sta. x
36	-2.5	0	1.313	-2.5
37	-3.25	0	1.125	-3.25
38	-4	0	1.125	-4
39	-4.75	0	1.125	-4.75
40	-5.5	0	1.313	-5.5
41	-2.5	1.5	3.75	-2.5
42	-4	1.5	4.5	-4
43	-5.5	1.5	3.75	-5.5
44	-2.5	3	4.375	-2.5
45	-4	3	5.25	-4
46	-5.5	3	4.375	-5.5
99	1.5	3	4.688	1.5
100	1.165	1.5	4.38	1.5
101	1.5	0	1.313	1.5
102	0.75	0	1.125	0.75
103	0	3	5.625	0
104	0	2	0.278	0
105	0	1.88	0.38	0
106	0	0.64	0.38	0
107	0	0.48	0.24	0
108	0	0.32	0.24	0
109	0	0.16	0.24	0
110	0	0	0.12	0
111	0	-0.16	0	0
112	0	-0.32	0	0
113	0	-0.48	0	0
114	0	-0.64	0	0
115	-0.75	2	0.375	-0.75
116	-0.75	1.75	0.375	-0.75
117	-0.75	1.5	0.355	-0.75
118	-0.75	1.25	0.325	-0.75
119	-0.75	1	0.355	-0.75
120	-0.75	0.75	0.375	-0.75
121	-0.75	0.5	0.375	-0.75
122	-0.75	0.25	0.375	-0.75
123	-0.75	0	0.188	-0.75
124	-1.5	3	4.688	-1.5
125	-1.5	2	0.438	-1.5
126	-1.5	1.75	0.438	-1.5
127	-1.5	1.5	0.438	-1.5
128	-1.5	1.25	0.438	-1.5
129	-1.5	1	0.438	-1.5
130	-1.5	0.75	0.438	-1.5
131	-1.5	0.5	0.438	-1.5
132	-1.5	0.25	0.438	-1.5
133	-1.5	0	0.219	-1.5

Conf. # 2C\_0\_2.5\_12/8, continued

Orif. #	Mom. arm	Sta. y	$\Delta$ .Area	Sta. x
58	5.5	0	1.313	5.5
59	4.75	0	1.125	4.75
60	4	0	1.125	4
61	3.25	0	1.125	3.25
62	2.5	0	1.313	2.5
63	5.5	1.5	3.75	5.5
64	4	1.5	4.5	4
65	2.5	1.5	3.75	2.5
66	5.5	3	4.375	5.5
67	4	3	5.25	4
68	2.5	3	4.375	2.5



Jet-Induced Pressure Increments  
 Configuration: 2C-0-2.5-12/8 Run 263

Point	1	2	3	4	5	6	7	8	9
Total Thrust =	24.96	16.64	12.47	8.30	6.63	4.95	3.29	2.47	1.61
NPR F/De =	26.11	26.07	26.05	26.00	25.97	25.95	25.62	25.60	25.60
NPR A/C =	1.00	1.00	1.00	1.00	1.00	1.00	1.00	1.00	1.00
X-loc	ACP	ACP	ACP	ACP	ACP	ACP	ACP	ACP	ACP
h/De =	0.54	0.000572	-0.000947	-0.001122	-0.000919	-0.003450	-0.004444	-0.003065	0.012066
AL/T =	-0.48	-0.000309	-0.000823	-0.000570	-0.001112	-0.002290	-0.005274	-0.003523	0.011304
Pressure	0.00	-0.000311	-0.000316	-0.000323	-0.000316	-0.000316	-0.000316	-0.000316	0.024789
Balance	0.00	-0.000316	-0.000316	-0.000316	-0.000316	-0.000316	-0.000316	-0.000316	0.039852
Pressure	5.50	-0.000225	-0.000330	-0.000310	-0.000326	-0.000309	-0.000319	-0.002275	0.000606
Balance	4.75	-0.000220	-0.000335	-0.000310	-0.000326	-0.000309	-0.000319	-0.002275	0.000606
Pressure	3.25	-0.000070	-0.000150	-0.000160	-0.000174	-0.000173	-0.000173	-0.000173	-0.002987
Balance	2.50	-0.000145	-0.000150	-0.000165	-0.000151	-0.000154	-0.000154	-0.000154	-0.001379
Pressure	1.50	-0.000246	-0.000386	-0.000459	-0.000582	-0.000605	-0.000605	-0.000605	0.038728
Balance	0.75	-0.000114	-0.000187	-0.000187	-0.000187	-0.000187	-0.000187	-0.000187	0.044607
Pressure	0.00	-0.000072	-0.000174	-0.000166	-0.000166	-0.000166	-0.000166	-0.000166	0.016507
Balance	-1.50	-0.000135	-0.000045	-0.000095	-0.000145	-0.000189	-0.000245	-0.000245	0.016507
Pressure	-3.25	-0.000185	-0.000170	-0.000095	-0.000145	-0.000189	-0.000245	-0.000245	0.016507
Balance	-4.75	-0.000195	-0.000140	-0.000095	-0.000145	-0.000189	-0.000245	-0.000245	0.016507
Pressure	-5.50	-0.000135	-0.000045	-0.000095	-0.000145	-0.000189	-0.000245	-0.000245	0.016507
Balance	0.00	-0.000098	-0.000110	-0.000093	-0.000113	-0.000113	-0.000113	-0.000113	0.043094
Pressure	-0.75	-0.000106	-0.000149	-0.000136	-0.000136	-0.000136	-0.000136	-0.000136	0.043094
Balance	-1.50	-0.000178	-0.000225	-0.000170	-0.000132	-0.000132	-0.000132	-0.000132	0.043094
Pressure	0.00	-0.000200	-0.000339	-0.000374	-0.000374	-0.000374	-0.000374	-0.000374	0.043094
Balance	-0.75	-0.000237	-0.000106	-0.000212	-0.000212	-0.000212	-0.000212	-0.000212	0.043094
Pressure	-1.50	-0.000131	-0.000123	-0.000204	-0.000260	-0.000260	-0.000260	-0.000260	0.043094
Balance	0.00	-0.000386	-0.000255	-0.000247	-0.000247	-0.000247	-0.000247	-0.000247	0.043094
Pressure	-1.50	-0.000174	-0.000183	-0.000246	-0.000246	-0.000246	-0.000246	-0.000246	0.043094
Balance	-1.50	-0.000585	-0.000577	-0.000748	-0.001273	-0.001705	-0.002235	-0.002765	0.043094
Pressure	5.50	-0.000200	-0.000270	-0.000575	-0.000706	-0.001625	-0.002149	-0.002673	0.043094
Balance	4.00	-0.000115	-0.000335	-0.000370	-0.000736	-0.001174	-0.001567	-0.001951	0.043094
Pressure	2.50	-0.000309	-0.000345	-0.000265	-0.000521	-0.001530	-0.002571	-0.003612	0.043094
Balance	-0.75	-0.000534	-0.000560	-0.000578	-0.000647	-0.001167	-0.002477	-0.004177	0.043094
Pressure	-2.50	-0.000212	-0.000391	-0.000297	-0.000553	-0.001278	-0.002414	-0.004177	0.043094
Balance	-5.50	-0.000254	-0.000155	-0.000240	-0.000296	-0.001570	-0.002314	-0.003051	0.043094
Pressure	-4.00	-0.000274	-0.000215	-0.000440	-0.000571	-0.001490	-0.001948	-0.002661	0.043094
Balance	-1.50	-0.000472	-0.000348	-0.000357	-0.000549	-0.001108	-0.001992	-0.002661	0.043094
Pressure	0.00	-0.000462	-0.001062	-0.001103	-0.000876	-0.002225	-0.002964	-0.003612	0.043094
Balance	0.00	-0.000415	-0.000624	-0.000671	-0.001391	-0.001875	-0.002495	-0.003142	0.043094
Pressure	-0.75	-0.000195	-0.000310	-0.000395	-0.000689	-0.001142	-0.001993	-0.002730	0.043094
Balance	5.50	-0.000279	-0.000460	-0.000575	-0.000922	-0.001470	-0.002126	-0.002730	0.043094
Pressure	3.00	-0.000165	-0.000379	-0.000460	-0.000810	-0.001157	-0.001628	-0.002289	0.043094
Balance	2.50	-0.000411	-0.000501	-0.000599	-0.000949	-0.001240	-0.001628	-0.002289	0.043094
Pressure	0.00	-0.000521	-0.000501	-0.000845	-0.001077	-0.001292	-0.001628	-0.002289	0.043094
Balance	-1.50	-0.000407	-0.000607	-0.000845	-0.001182	-0.001628	-0.002289	-0.002987	0.043094
Pressure	-2.50	-0.000359	-0.000490	-0.000770	-0.001182	-0.001628	-0.002289	-0.002987	0.043094
Balance	-4.00	-0.000274	-0.000200	-0.000325	-0.000631	-0.001149	-0.001628	-0.002289	0.043094
Pressure	-5.50	-0.000160	-0.000425	-0.000615	-0.000486	-0.001726	-0.002477	-0.003228	0.043094

Force and Moment Summary

h/De =	24.96	16.64	12.47	8.30	6.63	4.95	3.29	2.47	1.61
AL/T =	-0.010	-0.019	-0.024	-0.033	-0.050	-0.094	-0.170	-0.243	-0.383
Pressure	0.002	0.015	0.020	0.030	0.040	0.072	0.105	0.146	0.146
Balance	0.002	0.015	0.020	0.030	0.040	0.072	0.105	0.146	0.146
Pressure	0.001	-0.005	-0.002	-0.009	-0.005	-0.012	0.007	0.023	0.016
Balance	0.001	-0.005	-0.002	-0.009	-0.005	-0.012	0.007	0.023	0.016

Configuration: 2C-0-2.5-12/8 Jet-Induced Pressure Increments Run 264

Point	1	2	3	4	5	6	7	8
Total Thrust =	24.96	16.64	12.45	8.29	6.63	4.94	3.29	2.45
NPR Front =	67.81	67.80	67.79	67.73	67.70	67.68	67.63	67.64
NPR Aft =	4.10	4.10	4.10	4.10	4.10	4.10	4.09	4.10
X-loc	1.00	1.00	1.00	1.00	1.00	1.00	1.00	1.00
Y-loc	ACP	ACP	ACP	ACP	ACP	ACP	ACP	ACP
0.00	-0.00475	-0.000534	-0.000958	-0.000695	-0.001836	-0.003355	-0.003265	-0.010890
-0.68	-0.00187	-0.000336	-0.000232	-0.000456	-0.001667	-0.002839	-0.002487	-0.009178
0.00	-0.00089	-0.000336	-0.000282	-0.000274	-0.001288	-0.002330	-0.002062	-0.012377
-0.32	-0.00018	-0.000235	-0.000183	-0.000274	-0.001043	-0.001980	-0.000372	-0.014846
0.00	-0.00136	-0.000242	-0.000228	-0.000560	-0.000826	-0.002116	-0.001518	-0.001115
4.75	-0.000136	-0.000242	-0.000228	-0.000560	-0.000826	-0.002116	-0.001518	-0.001115
0.00	-0.00046	-0.000248	-0.000235	-0.000340	-0.000825	-0.002345	-0.002206	-0.001110
3.25	-0.00046	-0.000248	-0.000235	-0.000340	-0.000825	-0.002345	-0.002206	-0.001110
1.50	-0.000175	-0.000176	-0.000310	-0.000338	-0.001025	-0.002216	-0.001200	-0.005688
0.75	-0.000175	-0.000176	-0.000310	-0.000338	-0.001025	-0.002216	-0.001200	-0.005688
0.00	-0.00054	-0.000075	-0.000074	-0.000309	-0.001435	-0.002146	-0.000524	-0.014518
-0.75	-0.00054	-0.000075	-0.000074	-0.000309	-0.001435	-0.002146	-0.000524	-0.014518
0.00	-0.00071	-0.000066	-0.000062	-0.000288	-0.000977	-0.002250	-0.000470	-0.003390
-1.50	-0.00071	-0.000066	-0.000062	-0.000288	-0.000977	-0.002250	-0.000470	-0.003390
-3.25	-0.00094	-0.000040	-0.000046	-0.000315	-0.001128	-0.002400	-0.000415	-0.003390
-4.00	-0.00110	-0.000131	-0.000131	-0.000452	-0.000951	-0.002437	-0.001462	-0.000849
-4.75	-0.00163	-0.000167	-0.000248	-0.000548	-0.000922	-0.002223	-0.001108	-0.000954
0.00	-0.00171	-0.000240	-0.000248	-0.000493	-0.000964	-0.001987	-0.000848	-0.000542
0.16	-0.00041	-0.000045	-0.000089	-0.000244	-0.001193	-0.002379	-0.000480	-0.014216
0.75	-0.00041	-0.000045	-0.000089	-0.000244	-0.001193	-0.002379	-0.000480	-0.014216
0.25	-0.00181	-0.000062	-0.000047	-0.000235	-0.001213	-0.002607	-0.001599	-0.011484
-1.50	-0.00181	-0.000062	-0.000047	-0.000235	-0.001213	-0.002607	-0.001599	-0.011484
0.32	-0.00152	-0.000166	-0.000204	-0.000333	-0.001233	-0.002312	-0.002702	-0.007685
0.00	-0.00335	-0.000330	-0.000367	-0.000484	-0.001517	-0.002370	-0.001558	-0.013883
0.48	-0.00335	-0.000330	-0.000367	-0.000484	-0.001517	-0.002370	-0.001558	-0.013883
0.75	-0.00135	-0.000039	-0.000078	-0.000315	-0.001442	-0.002182	-0.002132	-0.009816
-1.50	-0.00135	-0.000039	-0.000078	-0.000315	-0.001442	-0.002182	-0.002132	-0.009816
0.64	-0.00442	-0.000454	-0.000754	-0.000779	-0.001783	-0.002461	-0.002654	-0.004295
0.00	-0.00442	-0.000454	-0.000754	-0.000779	-0.001783	-0.002461	-0.002654	-0.004295
-0.75	-0.00246	-0.000260	-0.000318	-0.000552	-0.001349	-0.002333	-0.002459	-0.001875
0.75	-0.00246	-0.000260	-0.000318	-0.000552	-0.001349	-0.002333	-0.002459	-0.001875
1.00	-0.00357	-0.000390	-0.000413	-0.000641	-0.001491	-0.002255	-0.001872	-0.006252
-1.50	-0.00357	-0.000390	-0.000413	-0.000641	-0.001491	-0.002255	-0.001872	-0.006252
1.25	-0.00473	-0.000475	-0.000761	-0.000882	-0.001618	-0.002273	-0.004708	-0.005248
0.00	-0.00473	-0.000475	-0.000761	-0.000882	-0.001618	-0.002273	-0.004708	-0.005248
1.50	-0.00198	-0.000267	-0.000319	-0.000435	-0.001187	-0.001097	-0.001187	-0.003888
0.00	-0.00198	-0.000267	-0.000319	-0.000435	-0.001187	-0.001097	-0.001187	-0.003888
1.50	-0.00087	-0.000133	-0.000100	-0.000366	-0.001118	-0.001557	-0.001711	-0.007280
0.00	-0.00087	-0.000133	-0.000100	-0.000366	-0.001118	-0.001557	-0.001711	-0.007280
1.50	-0.000330	-0.000469	-0.000540	-0.000634	-0.001394	-0.002004	-0.000861	-0.007568
0.00	-0.000330	-0.000469	-0.000540	-0.000634	-0.001394	-0.002004	-0.000861	-0.007568
1.50	-0.000436	-0.000575	-0.000893	-0.000882	-0.001394	-0.002224	-0.002201	-0.009343
0.00	-0.000436	-0.000575	-0.000893	-0.000882	-0.001394	-0.002224	-0.002201	-0.009343
1.50	-0.00110	-0.000110	-0.000092	-0.000296	-0.001130	-0.000868	-0.002435	-0.008623
0.00	-0.00110	-0.000110	-0.000092	-0.000296	-0.001130	-0.000868	-0.002435	-0.008623
-2.50	-0.00142	-0.000110	-0.000069	-0.000673	-0.001180	-0.001119	-0.002555	-0.006935
0.00	-0.00142	-0.000110	-0.000069	-0.000673	-0.001180	-0.001119	-0.002555	-0.006935
-5.50	-0.00403	-0.000477	-0.000728	-0.000794	-0.000918	-0.000701	-0.001404	-0.003686
0.00	-0.00403	-0.000477	-0.000728	-0.000794	-0.000918	-0.000701	-0.001404	-0.003686
1.75	-0.00196	-0.000258	-0.000246	-0.000456	-0.001301	-0.001992	-0.003340	-0.009931
0.00	-0.00196	-0.000258	-0.000246	-0.000456	-0.001301	-0.001992	-0.003340	-0.009931
2.00	-0.000488	-0.000428	-0.000464	-0.000749	-0.001512	-0.002249	-0.006037	-0.009931
0.00	-0.000488	-0.000428	-0.000464	-0.000749	-0.001512	-0.002249	-0.006037	-0.009931
-0.75	-0.00227	-0.000237	-0.000353	-0.000665	-0.001316	-0.001841	-0.005248	-0.010518
0.00	-0.00227	-0.000237	-0.000353	-0.000665	-0.001316	-0.001841	-0.005248	-0.010518
1.50	-0.00184	-0.000378	-0.000305	-0.000662	-0.001164	-0.000893	-0.004011	-0.005354
0.00	-0.00184	-0.000378	-0.000305	-0.000662	-0.001164	-0.000893	-0.004011	-0.005354
3.00	-0.00257	-0.000588	-0.000440	-0.000841	-0.001567	-0.001374	-0.002098	-0.007858
0.00	-0.00257	-0.000588	-0.000440	-0.000841	-0.001567	-0.001374	-0.002098	-0.007858
1.50	-0.00315	-0.000397	-0.000482	-0.000775	-0.001383	-0.001549	-0.005094	-0.009712
0.00	-0.00315	-0.000397	-0.000482	-0.000775	-0.001383	-0.001549	-0.005094	-0.009712
3.00	-0.00206	-0.000281	-0.000439	-0.000711	-0.001340	-0.001848	-0.005433	-0.008843
0.00	-0.00206	-0.000281	-0.000439	-0.000711	-0.001340	-0.001848	-0.005433	-0.008843
-1.50	-0.00413	-0.000447	-0.000533	-0.000922	-0.001530	-0.001380	-0.006117	-0.009662
0.00	-0.00413	-0.000447	-0.000533	-0.000922	-0.001530	-0.001380	-0.006117	-0.009662
-2.50	-0.00079	-0.000313	-0.000436	-0.000864	-0.001495	-0.000966	-0.005703	-0.007975
0.00	-0.00079	-0.000313	-0.000436	-0.000864	-0.001495	-0.000966	-0.005703	-0.007975
-4.00	-0.00098	-0.000254	-0.000298	-0.000769	-0.001003	-0.000666	-0.004541	-0.004770
0.00	-0.00098	-0.000254	-0.000298	-0.000769	-0.001003	-0.000666	-0.004541	-0.004770
-5.50	-0.00144	-0.000323	-0.000505	-0.000564	-0.001001	-0.000626	-0.002198	-0.003230
0.00	-0.00144	-0.000323	-0.000505	-0.000564	-0.001001	-0.000626	-0.002198	-0.003230

Force and Moment Summary  
 Balance h/Da = 24.96 16.64 12.45 8.29 6.63 4.94 3.29 2.45  
 AL/T = -0.010 -0.013 -0.017 -0.028 -0.050 -0.087 -0.144 -0.220  
 Pressure AL/T = -0.009 -0.012 -0.015 -0.027 -0.051 -0.062 -0.119 -0.200  
 Balance AM/TDa = 0.015 0.013 0.015 0.024 0.028 0.039 0.050 0.077  
 Pressure AM/TDa = -0.002 -0.003 -0.001 -0.002 -0.002 -0.013 0.015 -0.008



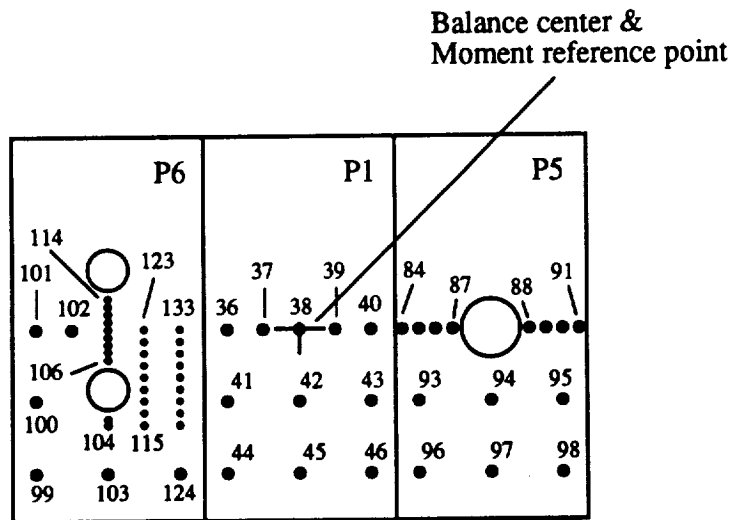

Figure 74. Configuration 3C\_8\_2.5\_12/8;  $D_e = 1.699$  in.,  $A_{jet} = 2.27$  in.<sup>2</sup>.

## Pressure Orifice Locations and Weighting Factors

Conf. # 3C-8-2.5-12/8

Distance from balance center to moment reference point,  $X_0 = 0$

Orif. #	Mom. arm	Sta. y	$\Delta$ .Area	Sta. x
99	5.5	3	4.688	5.5
100	5.165	1.5	4.38	5.5
101	5.5	0	1.313	5.5
102	4.75	0	1.125	4.75
103	4	3	5.625	4
104	4	2	0.278	4
105	4	1.88	0.38	4
106	4	0.64	0.38	4
107	4	0.48	0.24	4
108	4	0.32	0.24	4
109	4	0.16	0.24	4
110	4	0	0.12	4
111	4	-0.16	0	4
112	4	-0.32	0	4
113	4	-0.48	0	4
114	4	-0.64	0	4
115	3.25	2	0.375	3.25
116	3.25	1.75	0.375	3.25
117	3.25	1.5	0.355	3.25
118	3.25	1.25	0.325	3.25
119	3.25	1	0.355	3.25
120	3.25	0.75	0.375	3.25
121	3.25	0.5	0.375	3.25
122	3.25	0.25	0.375	3.25
123	3.25	0	0.188	3.25
124	2.5	3	4.688	2.5
125	2.5	2	0.438	2.5
126	2.5	1.75	0.438	2.5
127	2.5	1.5	0.438	2.5
128	2.5	1.25	0.438	2.5
129	2.5	1	0.438	2.5
130	2.5	0.75	0.438	2.5
131	2.5	0.5	0.438	2.5
132	2.5	0.25	0.438	2.5
133	2.5	0	0.219	2.5
36	1.5	0	1.313	1.5
37	0.75	0	1.125	0.75
38	0	0	1.125	0
39	-0.75	0	1.125	-0.75
40	-1.5	0	1.313	-1.5
41	1.5	1.5	3.75	1.5
42	0	1.5	4.5	0
43	-1.5	1.5	3.75	-1.5
44	1.5	3	4.375	1.5
45	0	3	5.25	0
46	-1.5	3	4.375	-1.5

Conf. # 3C\_8\_2.5\_12/8, continued

Orif. #	Mom. arm	Sta. y	Δ.Area	Sta. x
84	-2.15	0	0.634	-2.15
85	-2.5	0	0.683	-2.5
86	-2.85	0	0.683	-2.85
87	-3.2	0	0.619	-3.2
88	-4.8	0	0.619	-4.8
89	-5.15	0	0.683	-5.15
90	-5.5	0	0.683	-5.5
91	-5.85	0	0.634	-5.85
93	-2.5	1.5	3.19	-2.5
94	-4	1.5	5.062	-4
95	-5.5	1.5	3.19	-5.5
96	-2.5	3	4.375	-2.5
97	-4	3	5.25	-4
98	-5.5	3	4.375	-5.5

Configuration: 3C-8-2.5-12/8  
 Jet-Induced Pressure Increments  
 Run 268

Point	1	2	3	4	5	6	7	8	9
Total Thrust =	17.68	11.77	8.85	5.87	4.70	2.33	1.75	1.15	3.51
NPR Front =	51.62	51.18	50.91	50.74	50.71	50.66	50.74	50.66	50.63
NPR Aft =	2.06	2.05	2.04	2.04	2.04	2.04	2.04	2.04	2.04
X-Loc	2.00	1.99	1.98	1.98	1.98	1.97	1.98	1.97	1.97
Y-Loc	ACP	ACP	ACP	ACP	ACP	ACP	ACP	ACP	ACP
4.00	-0.001579	-0.001485	-0.001784	-0.001878	-0.018361	-0.016554	-0.006898	0.000131	-0.024014
4.00	-0.002191	-0.002076	-0.006868	-0.006868	-0.010979	-0.014291	-0.005749	0.000153	-0.014446
4.00	-0.001708	-0.006552	-0.001628	-0.005840	-0.010112	-0.010578	-0.005744	0.009729	-0.014115
4.00	-0.001143	-0.000587	-0.001376	-0.005626	-0.007742	-0.009809	-0.004455	0.022432	-0.010955
5.50	0.00	-0.000898	-0.001879	-0.001598	-0.002436	-0.002747	-0.002891	0.015508	-0.004002
4.75	0.00	-0.000938	-0.001407	-0.001350	-0.002482	-0.003956	-0.006848	-0.003188	0.021609
4.00	0.00	-0.000945	-0.000799	-0.001371	-0.004146	-0.007773	-0.011786	-0.036662	-0.011707
3.25	0.00	-0.001125	-0.001131	-0.001380	-0.003482	-0.005551	-0.010051	-0.032388	0.023917
2.50	0.00	-0.000908	-0.000695	-0.001072	-0.000758	-0.001639	-0.003289	0.010346	-0.003862
0.75	0.00	-0.002327	-0.000813	-0.001247	-0.000932	-0.003304	-0.006829	0.01062	-0.006308
0.00	-0.000252	-0.000361	-0.000756	0.004050	0.008559	0.025509	0.027496	0.018065	0.013011
0.00	-0.000257	-0.000513	-0.000557	0.005476	0.009752	0.015566	0.022015	0.050511	0.015779
-0.75	0.00	-0.000247	-0.001112	-0.000557	0.004281	0.006401	-0.003445	-0.023747	0.012438
-2.15	0.00	-0.000207	-0.001888	-0.000654	0.004742	0.003021	-0.008780	-0.015892	-0.023381
-2.50	0.00	-0.000307	-0.001332	-0.000393	0.001179	-0.009824	-0.015892	-0.019713	-0.018134
-2.85	0.00	-0.000645	-0.000518	-0.001032	0.002394	0.001503	-0.007420	-0.013859	-0.024545
-3.20	0.00	-0.0003079	-0.004045	-0.002774	0.003209	0.003842	-0.008932	-0.010803	-0.020895
-4.10	0.00	-0.001537	-0.002221	-0.001937	-0.001984	-0.005493	-0.005177	-0.006865	-0.006647
-5.15	0.00	-0.001411	-0.001672	-0.001849	-0.002112	-0.003524	-0.005832	-0.008942	-0.006588
-5.85	0.00	-0.000803	-0.001036	-0.001799	-0.001247	-0.001436	-0.005832	-0.008942	-0.006588
4.00	0.15	-0.000881	-0.001817	-0.001572	-0.005021	-0.008439	-0.009809	-0.002938	-0.011260
3.25	0.22	-0.000808	-0.000941	-0.001262	-0.001825	-0.005429	-0.008439	-0.002938	-0.011260
2.50	0.32	-0.000848	-0.002124	-0.001380	-0.006041	-0.009308	-0.008439	-0.002938	-0.011260
4.00	0.48	-0.000728	-0.000915	-0.001806	-0.006628	-0.012748	-0.014945	-0.014864	-0.006582
3.25	0.50	-0.000702	-0.000875	-0.001320	-0.006628	-0.011040	-0.008439	-0.002938	-0.011260
2.50	0.64	-0.000771	-0.000932	-0.001007	-0.001006	-0.001742	-0.003159	-0.005287	-0.006881
4.00	0.50	-0.001212	-0.001273	-0.002382	-0.011516	-0.017886	-0.007342	-0.005177	-0.002753
3.25	0.71	-0.000976	-0.001032	-0.001611	-0.003388	-0.008723	-0.007342	-0.005177	-0.002753
2.50	0.75	-0.001173	-0.001032	-0.001611	-0.003388	-0.008723	-0.007342	-0.005177	-0.002753
2.50	1.00	-0.001190	-0.001062	-0.001659	-0.001955	-0.001477	-0.005856	-0.004236	-0.005642
2.50	1.00	-0.001049	-0.001326	-0.000968	-0.001249	-0.000858	-0.005566	-0.004236	-0.005642
3.25	1.25	-0.001096	-0.001269	-0.001729	-0.002055	-0.000655	-0.004236	-0.004236	-0.005642
2.50	1.50	-0.000816	-0.000850	-0.001132	-0.002055	-0.001142	-0.004856	-0.003223	-0.001977
3.25	1.50	-0.000842	-0.001096	-0.001215	-0.001731	-0.002227	-0.003780	-0.005785	-0.003789
2.50	1.50	-0.000595	-0.001015	-0.001857	-0.001585	-0.001650	-0.003172	-0.003223	-0.003789
2.50	1.50	-0.000762	-0.001153	-0.000771	-0.000436	-0.003368	-0.003542	-0.003789	-0.003789
2.50	1.50	-0.000752	-0.000539	-0.000976	0.000464	0.003268	0.009507	0.014791	0.002519
2.50	1.50	-0.001024	-0.000218	-0.000976	0.000464	0.003268	0.009507	0.014791	0.002519
-2.00	1.50	-0.001008	-0.001596	-0.001524	-0.003977	-0.003697	-0.007318	-0.01212	-0.005528
-4.00	1.50	-0.001057	-0.001596	-0.001524	-0.003977	-0.003697	-0.007318	-0.01212	-0.005528
-5.25	1.75	-0.001457	-0.000960	-0.001957	-0.002137	-0.003475	-0.005425	-0.007748	-0.014398
3.25	1.75	-0.001859	-0.000541	-0.001271	-0.002092	-0.002649	-0.003666	-0.014864	-0.005021
2.50	1.75	-0.001932	-0.000632	-0.002520	-0.000462	-0.001627	-0.002459	-0.017389	-0.000253
4.00	2.00	-0.000745	-0.001941	-0.002982	-0.005032	-0.000921	-0.005832	-0.028697	-0.016021
3.25	2.00	-0.000979	-0.000704	-0.001889	-0.002425	-0.002318	-0.003832	-0.018163	-0.021080
2.50	2.00	-0.000809	-0.000436	-0.001389	-0.001894	-0.000824	-0.002360	-0.009749	-0.004167
3.50	3.00	-0.000668	-0.000673	-0.001092	-0.002239	-0.002827	-0.004475	-0.005148	-0.012432
4.00	3.00	-0.000608	-0.000470	-0.001376	-0.001050	-0.000414	-0.007611	-0.011518	-0.006759
1.50	3.00	-0.000161	-0.000239	-0.000390	0.000912	0.003128	0.008749	-0.004944	0.000545
0.00	3.00	-0.000101	-0.000813	-0.000892	0.004097	0.004703	-0.004091	-0.013039	0.004356
-1.50	3.00	-0.000096	-0.000239	-0.001395	0.000266	0.000677	-0.010344	-0.014690	-0.003765
-2.50	3.00	-0.001457	-0.000960	-0.002087	-0.002187	-0.003575	-0.005469	-0.007512	-0.006021
-4.00	3.00	-0.000585	-0.000508	-0.000812	-0.002286	-0.004129	-0.007030	-0.007264	-0.006745
-5.50	3.00	-0.000365	-0.000508	-0.000812	-0.002286	-0.004129	-0.007030	-0.007264	-0.006745

Force and Moment Summary  
 h/De = 17.68  
 Balance AL/T = -0.013  
 Pressure AL/T = -0.014  
 Balance AH/TDe = -0.006  
 Pressure AH/TDe = 0.003

Configuration: 3C-8-2.5-12/8 Jet-Induced Pressure Increments Run 269

Point	1	2	3	4	5	6	7	8
h/D <sub>e</sub> =	17.66	11.80	8.83	5.90	4.71	3.51	2.34	1.75
Total Thrust =	136.69	136.47	136.28	136.17	137.91	136.41	136.30	136.32
NER Front =	4.08	4.07	4.07	4.07	4.10	4.07	4.07	4.07
NER Aft =	4.01	4.01	4.00	3.99	4.04	4.00	4.00	4.00
X-loc	ACP	ACP	ACP	ACP	ACP	ACP	ACP	ACP
Y-loc	ACP	ACP	ACP	ACP	ACP	ACP	ACP	ACP
4.00	-0.002648	-0.001483	-0.001524	-0.008209	-0.013818	-0.019121	-0.023116	-0.010853
-0.48	-0.001170	-0.001370	-0.001112	-0.006695	-0.009947	-0.015822	-0.014771	-0.009031
4.00	-0.000629	-0.000991	-0.001062	-0.005237	-0.008347	-0.010945	-0.012211	-0.009104
-0.16	-0.000682	-0.000967	-0.000981	-0.003923	-0.007989	-0.010234	-0.012560	-0.006727
4.00	-0.000590	-0.000936	-0.000830	-0.001066	-0.001670	-0.002496	-0.003158	-0.003169
5.50	0.00	-0.000778	-0.000845	-0.000688	-0.001384	-0.002475	-0.004570	-0.005558
4.75	0.00	-0.000837	-0.001020	-0.000815	-0.003520	-0.007292	-0.011562	-0.007269
4.00	-0.000595	-0.000758	-0.001015	-0.002530	-0.004530	-0.006211	-0.012294	-0.009403
3.25	0.00	-0.000508	-0.000722	-0.001196	-0.002231	-0.004107	-0.007350	-0.008446
1.50	0.00	-0.002084	-0.004084	-0.003802	-0.006125	-0.008575	-0.006631	-0.009521
0.75	0.00	-0.00152	-0.00288	-0.003582	-0.006815	-0.012924	-0.017287	-0.024802
0.00	-0.000266	-0.00439	-0.000456	-0.003659	-0.007561	-0.011127	-0.019192	-0.023273
0.00	-0.00122	-0.00107	-0.00263	-0.002991	-0.004699	-0.006662	-0.008915	-0.003879
-1.50	0.00	-0.00055	-0.00055	-0.000445	-0.002101	-0.000824	-0.002576	-0.010388
-2.15	0.00	-0.000255	-0.000404	-0.000464	-0.002253	-0.003687	-0.008251	-0.016060
-2.50	0.00	-0.00015	-0.00023	-0.00023	-0.000823	-0.002143	-0.004416	-0.014607
-2.85	0.00	-0.000561	-0.001313	-0.000595	-0.000815	-0.000532	-0.000915	-0.004873
-3.20	0.00	-0.001129	-0.002813	-0.000800	-0.002099	-0.003612	-0.004772	-0.01282
-4.80	0.00	-0.001199	-0.002813	-0.001643	-0.002920	-0.004502	-0.005538	-0.004617
-5.15	0.00	-0.001205	-0.001784	-0.001659	-0.001943	-0.003163	-0.004876	-0.004893
-5.50	0.00	-0.000972	-0.001424	-0.001395	-0.001580	-0.002529	-0.004654	-0.003886
-5.85	0.00	-0.000923	-0.001147	-0.001233	-0.001247	-0.002020	-0.003089	-0.004131
3.25	0.00	-0.000739	-0.001109	-0.000950	-0.003939	-0.007108	-0.010849	-0.011582
2.50	0.00	-0.000519	-0.00052	-0.000795	-0.00123	-0.003361	-0.011582	-0.009084
4.00	-0.00805	-0.00084	-0.001003	-0.004392	-0.008663	-0.013131	-0.012766	-0.008073
4.00	-0.00753	-0.000653	-0.001289	-0.006159	-0.011370	-0.017543	-0.018554	-0.007897
3.25	0.00	-0.00684	-0.000693	-0.001036	-0.001361	-0.001996	-0.004763	-0.007768
2.50	0.00	-0.00567	-0.000557	-0.000879	-0.000923	-0.002286	-0.001087	-0.006475
4.00	-0.00683	-0.002009	-0.001819	-0.008595	-0.017590	-0.023829	-0.024851	-0.011029
3.25	0.00	-0.00781	-0.000976	-0.001106	-0.000146	-0.000957	-0.001730	-0.006977
2.50	-0.00642	-0.000900	-0.000836	-0.001284	-0.002575	-0.002692	-0.006967	-0.006737
3.25	1.00	-0.000905	-0.00068	-0.001012	-0.000728	-0.001647	-0.001454	-0.003592
2.50	0.00	-0.00841	-0.000658	-0.000830	-0.001558	-0.002658	-0.004703	-0.006727
2.50	1.50	-0.000701	-0.001452	-0.001530	-0.001629	-0.003230	-0.000251	-0.003622
2.50	1.25	-0.000723	-0.000581	-0.000916	-0.001554	-0.003437	-0.002687	-0.004204
2.50	1.00	-0.006403	-0.001071	-0.000820	-0.000954	-0.003351	-0.003826	-0.004952
3.25	1.20	-0.000520	-0.000560	-0.000971	-0.002041	-0.000396	-0.002041	-0.008625
2.50	1.50	-0.000217	-0.000981	-0.000971	-0.002074	-0.001617	-0.003673	-0.007046
0.00	-0.000852	-0.000242	-0.000615	-0.003117	-0.006647	-0.010103	-0.010292	-0.009444
-1.50	0.00	-0.00018	-0.000900	-0.000307	-0.00168	-0.001465	-0.006689	-0.015096
-2.50	1.50	-0.001018	-0.000900	-0.001306	-0.008159	-0.011078	-0.014172	-0.014800
-4.00	1.50	-0.001052	-0.001498	-0.001424	-0.002025	-0.003189	-0.004521	-0.004999
-5.50	1.50	-0.001112	-0.001392	-0.001484	-0.002021	-0.000091	-0.001045	-0.006625
3.25	1.75	-0.000456	-0.001917	-0.001206	-0.001274	-0.002035	-0.002524	-0.001219
2.50	1.75	-0.000456	-0.001804	-0.002007	-0.004931	-0.012188	-0.019846	-0.025746
4.00	2.00	-0.000975	-0.000866	-0.001200	-0.002395	-0.001189	-0.002298	-0.008713
3.25	2.00	-0.000338	-0.000479	-0.001331	-0.000995	-0.002506	-0.001365	-0.006398
2.50	3.00	-0.000435	-0.000602	-0.000942	-0.001037	-0.001942	-0.003817	-0.004766
4.00	3.00	-0.000435	-0.000614	-0.000953	-0.000700	-0.002091	-0.003650	-0.0011365
2.50	3.00	-0.000305	-0.000696	-0.001051	-0.000933	-0.001123	-0.002731	-0.001793
1.50	3.00	-0.000317	-0.000933	-0.000907	-0.001832	-0.003798	-0.005718	-0.006259
0.00	3.00	-0.000624	-0.001300	-0.000723	-0.001356	-0.001424	-0.003416	-0.006632
-2.50	3.00	-0.00052	-0.001496	-0.000824	-0.001185	-0.001146	-0.008819	-0.013470
-4.00	3.00	-0.000405	-0.000432	-0.000589	-0.001329	-0.003489	-0.004952	-0.004195
-5.50	3.00	-0.000405	-0.000432	-0.000589	-0.001329	-0.003489	-0.004952	-0.004195

Force and Moment Summary	
h/D <sub>e</sub> =	17.66
Balance AL/T =	-0.010
Pressure AL/T =	-0.018
Balance AH/TDe =	0.002
Pressure AH/TDe =	0.003
5.90	4.71
-0.006	-0.011
-0.016	-0.019
0.017	0.026
0.040	0.058
8.83	5.90
-0.016	-0.006
-0.018	-0.016
-0.002	0.001
0.001	0.003
11.80	8.83
-0.013	-0.016
-0.018	-0.018
-0.000	-0.002
0.003	0.003
1.75	2.34
-0.088	-0.070
-0.082	-0.052
0.058	0.065
0.038	0.065



Configuration: 3C-8-2.5-12/8  
Run 270

Point	1	2	3	4	5	6	7	8
h/Da =	17.66	11.78	8.83	5.89	4.69	3.51	2.35	1.74
h/Dc =	220.49	220.41	220.34	220.28	220.17	220.17	219.92	222.80
NPR Front =	6.05	6.04	6.04	6.04	6.04	6.03	6.03	6.09
NPR Aft =	5.98	5.98	5.97	5.97	5.97	5.97	5.96	6.02
X-loc	ACP	ACP	ACP	ACP	ACP	ACP	ACP	ACP
Y-loc	ACP	ACP	ACP	ACP	ACP	ACP	ACP	ACP
4.00	-0.001037	-0.001782	-0.001940	-0.009346	-0.014224	-0.023322	-0.013310	-0.000851
4.00	-0.001074	-0.002144	-0.001683	-0.007086	-0.010029	-0.015976	-0.010013	-0.001485
4.00	-0.000868	-0.001351	-0.001332	-0.004204	-0.008397	-0.012969	-0.007918	-0.001270
4.00	-0.000770	-0.000663	-0.001223	-0.003904	-0.006562	-0.011744	-0.007213	-0.000503
5.00	0.00	-0.000679	-0.000846	-0.001009	-0.001309	-0.002755	-0.002504	0.005119
4.75	0.00	-0.000488	-0.000631	-0.000923	-0.001273	-0.002441	-0.004594	-0.003958
4.00	0.00	-0.000886	-0.001076	-0.001278	-0.001651	-0.002875	-0.012071	-0.006541
3.25	0.00	-0.000407	-0.000655	-0.001392	-0.001308	-0.002215	-0.007099	-0.008416
2.50	0.00	-0.000184	-0.000492	-0.000839	-0.001269	-0.001683	-0.000533	-0.001077
1.50	0.00	-0.000106	-0.000386	-0.000771	-0.001262	-0.002274	-0.006263	-0.002031
0.75	0.00	-0.000233	-0.000199	-0.000531	-0.000445	-0.002276	-0.011826	-0.005634
0.00	0.00	-0.000106	-0.000296	-0.000417	-0.003119	-0.006333	-0.013074	-0.013690
-0.75	0.00	-0.000211	-0.000099	-0.000143	-0.002037	-0.004264	-0.008722	-0.016787
-1.50	0.00	-0.000664	-0.000224	0.000085	0.002008	0.002673	0.003231	0.011048
-2.15	0.00	-0.00153	-0.00106	-0.000322	-0.000621	-0.000284	0.000626	-0.012098
-2.50	0.00	-0.000370	-0.000288	-0.000465	-0.000575	-0.000136	-0.000203	-0.000321
-2.85	0.00	-0.001102	-0.000786	-0.000581	-0.000839	-0.000753	-0.001385	-0.006360
-3.20	0.00	-0.001819	-0.002364	-0.001289	-0.001161	-0.003334	-0.006285	-0.017215
-4.80	0.00	-0.002241	-0.002251	-0.002134	-0.002937	-0.003832	-0.006643	-0.008075
-5.15	0.00	-0.001447	-0.001494	-0.001258	-0.001934	-0.002982	-0.004329	-0.006181
-5.50	0.00	-0.000962	-0.001343	-0.000852	-0.001411	-0.002320	-0.003802	-0.005961
-5.85	0.00	-0.000629	-0.001254	-0.001028	-0.001026	-0.001756	-0.002458	-0.003987
4.00	0.16	-0.000779	-0.000823	-0.001282	-0.003764	-0.006338	-0.010462	-0.006522
3.25	0.25	-0.000480	-0.000505	-0.001444	-0.001275	-0.003188	-0.006471	-0.009129
2.50	0.32	-0.001066	-0.000887	-0.001300	-0.005109	-0.009438	-0.013780	-0.007501
4.00	0.48	-0.001200	-0.000522	-0.001662	-0.005457	-0.009438	-0.015515	-0.007353
3.25	0.50	-0.000862	-0.000881	-0.001447	-0.000480	-0.001323	-0.004909	-0.007990
2.50	0.50	-0.000468	-0.000513	-0.001106	-0.001536	-0.001058	-0.000225	-0.007351
4.00	0.64	-0.001679	-0.002115	-0.002193	-0.008497	-0.014045	-0.021119	-0.011816
3.25	0.75	-0.000468	-0.000483	-0.001389	-0.001115	-0.000555	-0.002229	-0.005638
2.50	1.00	-0.000717	-0.001025	-0.000997	-0.001545	-0.001237	-0.000197	-0.007386
3.25	1.00	-0.000434	-0.000486	-0.001233	-0.001562	-0.002036	-0.002316	-0.002916
3.25	1.25	-0.000791	-0.000950	-0.001366	-0.001249	-0.002181	-0.003613	-0.007736
2.50	1.25	-0.000958	-0.000781	-0.001142	-0.002377	-0.001942	-0.000788	-0.007410
5.50	1.50	-0.000631	-0.001703	-0.001086	-0.001294	-0.001915	-0.003357	-0.003448
3.25	1.50	-0.000352	-0.000997	-0.001113	-0.000918	-0.001168	-0.001233	-0.003574
2.50	1.50	-0.000808	-0.000230	-0.000720	-0.002601	-0.004165	-0.007660	-0.015165
0.00	1.50	-0.000660	-0.000191	-0.000543	-0.005029	-0.009828	-0.009828	-0.016368
1.50	1.50	-0.000327	-0.000513	-0.000345	-0.001058	-0.000902	-0.000237	-0.003821
-2.50	1.50	-0.000803	-0.001121	-0.001355	-0.007851	-0.011362	-0.019958	-0.032109
-4.00	1.50	-0.000993	-0.001114	-0.001223	-0.001845	-0.002951	-0.004560	-0.006960
-5.50	1.75	-0.000846	-0.001690	-0.001510	-0.000001	-0.000777	-0.000871	-0.007540
2.50	1.75	-0.000308	-0.000601	-0.001111	-0.000711	-0.001514	-0.001625	-0.007211
4.00	1.88	-0.002229	-0.002732	-0.002030	-0.007509	-0.013129	-0.021469	-0.017564
2.00	2.00	-0.001124	-0.000956	-0.001656	-0.004056	-0.008504	-0.014661	-0.014240
3.25	2.00	-0.000437	-0.000672	-0.001241	-0.000841	-0.001710	-0.002850	-0.009312
5.50	2.00	-0.000319	-0.000668	-0.000923	-0.001696	-0.001755	-0.002267	-0.007897
4.00	3.00	-0.000639	-0.000553	-0.001037	-0.001231	-0.001687	-0.003013	-0.003135
5.50	3.00	-0.000545	-0.000315	-0.001003	-0.000337	-0.000889	-0.001503	-0.006450
1.50	3.00	-0.000703	-0.001173	-0.000934	-0.000837	-0.002116	-0.006749	-0.004246
0.00	3.00	-0.000351	-0.000264	-0.000652	-0.001249	-0.003521	-0.004904	-0.010168
-1.50	3.00	-0.000567	-0.000166	-0.000891	-0.001249	-0.000719	-0.001578	-0.004387
-2.50	3.00	-0.000993	-0.001114	-0.001223	-0.001845	-0.002951	-0.004560	-0.006960
-4.00	3.00	-0.000436	-0.000595	-0.000473	-0.001775	-0.003340	-0.005498	-0.007445
-5.50	3.00	-0.000436	-0.000595	-0.000473	-0.001775	-0.003340	-0.005498	-0.007445

Force and Moment Summary

Balance h/Da =	17.66	11.78	8.83	5.89	4.69	3.51	2.35	1.74
Balance AL/T =	-0.010	-0.013	-0.015	-0.011	-0.024	-0.047	-0.088	-0.109
Balance AU/T =	-0.012	-0.018	-0.018	-0.016	-0.022	-0.039	-0.072	-0.079
Balance AH/TDe =	0.001	0.005	-0.007	0.022	0.040	0.045	0.046	0.055
Balance AU/TDe =	0.001	0.005	-0.002	0.033	0.055	0.087	0.106	0.089

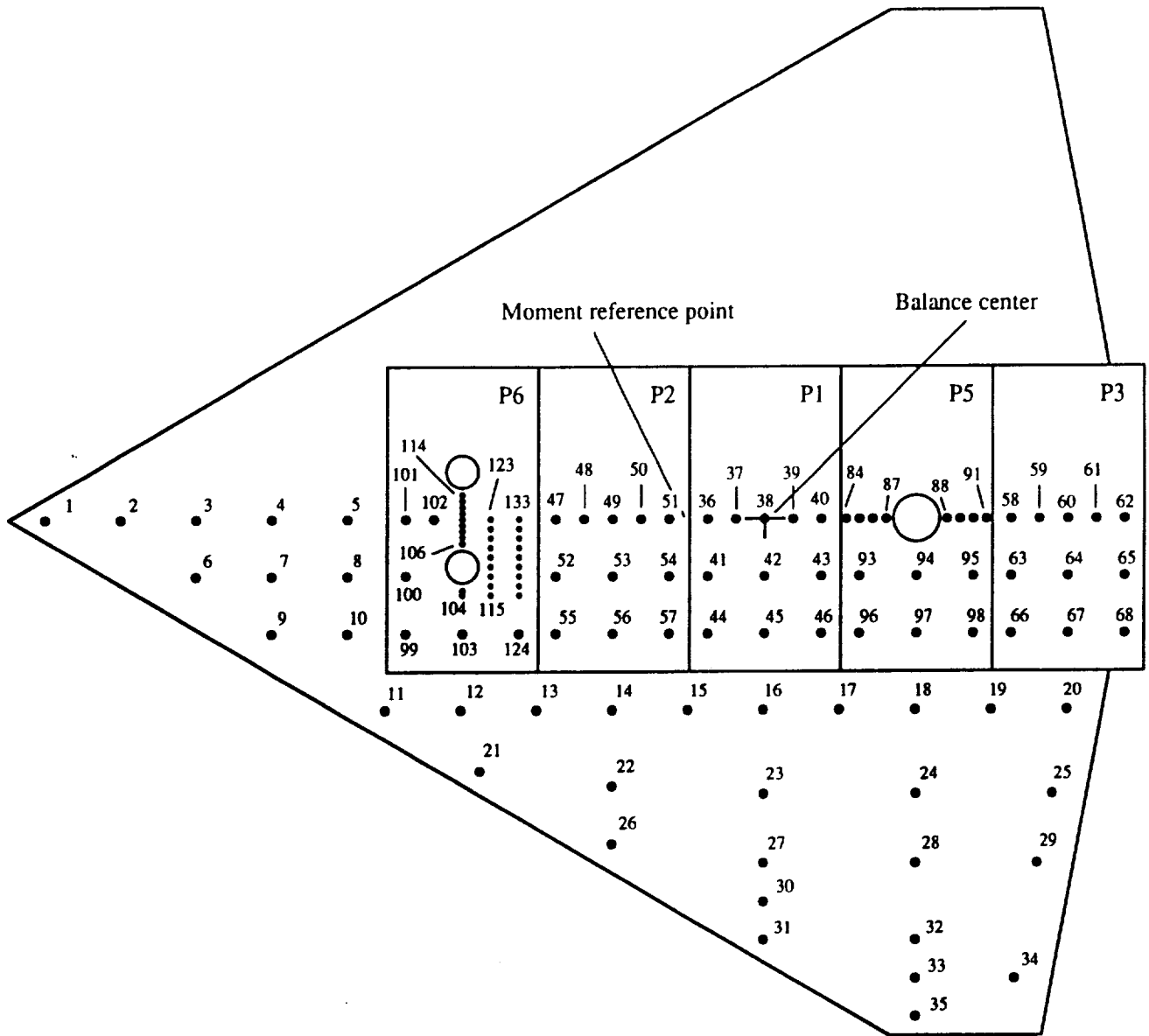

Figure 75. Configuration 3C\_12\_2.5\_DW;  $D_e = 1.699$  in.,  $A_{jet} = 2.27$  in.<sup>2</sup>.

Pressure Orifice Locations and Weighting Factors

Conf. # 3C-12-2.5-DW

Distance from balance center to moment reference point,  $X_0 = 2$

Orif. #	Mom. arm	Sta. y	$\Delta$ .Area	Sta. x
1	16.6	0	2.3	17
2	14.86	0	6.918	15
3	13	0	3	13
4	11	0	3	11
5	9	0	3	9
6	13	1.5	8.546	13
7	11	1.5	6	11
8	9	1.5	6	9
9	10.87	3	7.166	11
10	9	3	7	9
11	8.14	5	8.91	8
12	6	5	8	6
13	4	5	8	4
14	2	5	8	2
15	0	5	8	0
16	-2	5	8	-2
17	-4	5	8	-4
18	-6	5	8	-6
19	-8	5	8	-8
20	-9.91	5	8.06	-10
21	5.06	6.6	7.302	5.5
22	2	7	16	2
23	-2	7	16	-2
24	-6	7	16	-6
25	-9.31	7	10.484	-9.6
26	1.235	8.5	9.904	-2
27	-2	9	12	-2
28	-6	9	16	-6
29	-9.11	9	8.908	-9.2
30	-2	10	8	-2
31	-2.84	11	8.376	-2
32	-6	11	12	-6
33	-6	12	8	-6
34	-8.86	12	12.005	-8.6
35	-6.17	13	6.883	-6
99	7.5	3	4.688	7.5
100	7.165	1.5	4.38	7.5
101	7.5	0	1.313	7.5
102	6.75	0	1.125	6.75
103	6	3	5.625	6
104	6	2	0.278	6
105	6	1.88	0.38	6
106	6	0.64	0.38	6
107	6	0.48	0.24	6
108	6	0.32	0.24	6
109	6	0.16	0.24	6

Conf. # 3C\_12\_2.5\_DW, continued

Orif. #	Mom. arm	Sta. y	Δ.Area	Sta. x
110	6	0	0.12	6
111	6	-0.16	0	6
112	6	-0.32	0	6
113	6	-0.48	0	6
114	6	-0.64	0	6
115	5.25	2	0.375	5.25
116	5.25	1.75	0.375	5.25
117	5.25	1.5	0.355	5.25
118	5.25	1.25	0.325	5.25
119	5.25	1	0.355	5.25
120	5.25	0.75	0.375	5.25
121	5.25	0.5	0.375	5.25
122	5.25	0.25	0.375	5.25
123	5.25	0	0.188	5.25
124	4.5	3	4.688	4.5
125	4.5	2	0.438	4.5
126	4.5	1.75	0.438	4.5
127	4.5	1.5	0.438	4.5
128	4.5	1.25	0.438	4.5
129	4.5	1	0.438	4.5
130	4.5	0.75	0.438	4.5
131	4.5	0.5	0.438	4.5
132	4.5	0.25	0.438	4.5
133	4.5	0	0.219	4.5
47	3.5	0	1.313	3.5
48	2.75	0	1.125	2.75
49	2	0	1.125	2
50	1.25	0	1.125	1.25
51	0.5	0	1.313	0.5
52	3.5	1.5	3.75	3.5
53	2	1.5	4.5	2
54	0.5	1.5	3.75	0.5
55	3.5	3	4.375	3.5
56	2	3	5.25	2
57	0.5	3	4.375	0.5
36	-0.5	0	1.313	-0.5
37	-1.25	0	1.125	-1.25
38	-2	0	1.125	-2
39	-2.75	0	1.125	-2.75
40	-3.5	0	1.313	-3.5
41	-0.5	1.5	3.75	-0.5
42	-2	1.5	4.5	-2
43	-3.5	1.5	3.75	-3.5
44	-0.5	3	4.375	-0.5
45	-2	3	5.25	-2
46	-3.5	3	4.375	-3.5
84	-4.15	0	0.634	-4.15
85	-4.5	0	0.683	-4.5
86	-4.85	0	0.683	-4.85
87	-5.2	0	0.619	-5.2
88	-6.8	0	0.619	-6.8

Conf. # 3C\_12\_2.5\_DW, continued

Orif. #	Mom. arm	Sta. y	$\Delta$ .Area	Sta. x
89	-7.15	0	0.683	-7.15
90	-7.5	0	0.683	-7.5
91	-7.85	0	0.634	-7.85
93	-4.5	1.5	3.19	-4.5
94	-6	1.5	5.062	-6
95	-7.5	1.5	3.19	-7.5
96	-4.5	3	4.375	-4.5
97	-6	3	5.25	-6
98	-7.5	3	4.375	-7.5
58	-8.5	0	1.313	-8.5
59	-9.25	0	1.125	-9.25
60	-10	0	1.125	-10
61	-10.75	0	1.125	-10.75
62	-11.5	0	1.313	-11.5
63	-8.5	1.5	3.75	-8.5
64	-10	1.5	4.5	-10
65	-11.5	1.5	3.75	-11.5
66	-8.5	3	4.375	-8.5
67	-10	3	5.25	-10
68	-11.5	3	4.375	-11.5

Point	1	2	3	4	5	7	8	9	10	11
Total Thrust =	33.89	17.66	11.78	8.83	5.86	3.50	2.33	1.77	1.17	5.89
NPR Front =	51.61	51.38	51.23	51.29	51.23	51.17	51.16	51.15	51.16	51.23
NPR Aft =	2.06	2.05	2.04	2.04	2.04	2.04	2.04	2.04	2.04	2.04
X-loc	1.99	1.98	1.98	1.98	1.98	1.98	1.98	1.98	1.98	1.98
Y-loc	ACP	ACP	ACP	ACP	ACP	ACP	ACP	ACP	ACP	ACP
6.00	-0.00475	-0.000813	-0.002303	-0.006467	-0.009353	-0.009277	-0.006107	0.000851	0.015047	-0.009990
6.00	-0.00319	-0.000916	-0.000723	-0.004636	-0.006801	-0.007509	-0.006133	0.003011	0.011618	-0.007952
6.00	-0.00981	-0.001015	-0.000482	-0.004907	-0.005977	-0.006392	-0.004613	0.004544	0.024800	-0.006447
6.00	-0.00044	-0.000542	-0.001059	-0.003943	-0.005943	-0.006412	-0.004811	0.006643	0.024859	-0.005110
17.00	0.00	-0.000995	-0.00106	-0.000448	-0.000736	-0.000640	-0.000192	0.000638	0.002659	-0.001074
15.00	0.00	-0.00140	-0.000800	-0.000347	-0.000519	-0.0000712	0.000091	0.000839	0.000581	-0.000898
13.00	0.00	-0.00155	-0.000181	-0.000337	-0.000675	-0.0000818	0.000242	0.000071	0.001228	-0.000543
11.00	0.00	-0.00105	-0.000252	-0.000357	-0.000675	-0.000889	0.001177	-0.000611	-0.000349	-0.001206
7.50	0.00	-0.00248	-0.000249	-0.000697	-0.002451	-0.003286	-0.001900	0.000577	0.015631	-0.003532
6.75	0.00	-0.00141	-0.000348	-0.000702	-0.004494	-0.004228	-0.002820	0.009565	0.024385	-0.003547
6.25	0.00	-0.000931	-0.000753	-0.000396	-0.001383	-0.005367	-0.003473	0.013755	0.024385	-0.003547
6.00	0.00	-0.000745	-0.000618	-0.000499	-0.001262	-0.002829	-0.001722	0.006743	0.046681	-0.003584
4.50	0.00	-0.00312	-0.000628	-0.000730	-0.001100	-0.002553	-0.006324	0.016730	0.016730	-0.002423
2.75	0.00	-0.00287	-0.000360	-0.000639	-0.000984	-0.003041	-0.003965	-0.005023	-0.003696	-0.001345
2.00	0.00	-0.00161	-0.000289	-0.000517	-0.001252	-0.002802	-0.001464	-0.002812	-0.000717	-0.002818
1.25	0.00	-0.00141	-0.000162	-0.000492	-0.001176	-0.002701	-0.001525	-0.000407	0.005364	-0.002944
0.50	0.00	-0.00070	-0.000096	-0.000476	-0.001243	-0.002737	-0.001963	0.001963	0.009138	-0.003000
-0.50	0.00	-0.00030	-0.000035	-0.000431	-0.001233	-0.002442	-0.003766	0.002760	0.003340	-0.002751
-1.25	0.00	-0.00010	-0.000020	-0.000411	-0.000888	-0.003904	-0.004813	-0.011119	-0.033773	-0.001421
-2.00	0.00	-0.00030	-0.000005	-0.000385	-0.000801	-0.002020	-0.001073	-0.008913	-0.021184	-0.003492
-2.75	0.00	-0.00015	-0.000025	-0.000218	-0.001126	-0.001432	-0.002105	-0.011240	-0.035492	-0.000548
-3.50	0.00	-0.00070	-0.000020	-0.000390	-0.000715	-0.000934	-0.001103	-0.012347	-0.024117	-0.000609
-4.15	0.00	-0.00096	-0.000041	-0.000522	-0.000776	-0.000948	-0.001131	-0.011949	-0.03352	-0.000472
-4.50	0.00	-0.00197	-0.000400	-0.000882	-0.001736	-0.002020	-0.005212	-0.010779	-0.022909	-0.001127
-4.85	0.00	-0.00124	-0.001235	-0.001728	-0.002150	-0.001340	-0.001947	-0.007494	-0.011597	-0.000787
-5.20	0.00	-0.001341	-0.001089	-0.001789	-0.002572	-0.003354	-0.005655	-0.008655	-0.017074	-0.002584
-6.80	0.00	-0.00615	-0.000309	-0.001029	-0.001106	-0.001523	-0.003808	-0.004881	-0.007099	-0.017048
-7.15	0.00	-0.00443	-0.000537	-0.000861	-0.001275	-0.001819	-0.003819	-0.006402	-0.017278	-0.001691
-7.85	0.00	-0.00257	-0.000471	-0.000791	-0.000685	-0.002041	-0.002821	-0.003665	-0.017996	-0.002416
-8.50	0.00	-0.00302	-0.000324	-0.000634	-0.000462	-0.001879	-0.002654	-0.003559	-0.007430	-0.019794
-9.25	0.00	-0.00388	-0.000364	-0.000654	-0.000456	-0.001868	-0.002344	-0.003839	-0.008273	-0.024587
-10.00	0.00	-0.00292	-0.000258	-0.000573	-0.000365	-0.001452	-0.001825	-0.003762	-0.008375	-0.027404
-11.50	0.00	-0.00126	-0.000253	-0.000735	-0.000685	-0.001780	-0.002680	-0.003620	-0.008182	-0.031009
6.00	0.16	-0.00394	-0.000813	-0.000951	-0.004101	-0.005356	-0.006196	0.003166	0.014916	-0.000756
5.25	0.35	-0.00681	-0.000705	-0.000538	-0.001577	-0.002678	-0.004503	0.006915	0.005685	-0.005982
4.50	0.32	-0.001032	-0.000748	-0.000972	-0.001151	-0.002730	-0.007138	-0.007169	-0.005417	-0.002359
6.00	0.48	-0.00621	-0.001015	-0.000904	-0.004441	-0.006482	-0.007492	-0.004422	0.013614	-0.002474
5.25	0.50	-0.00621	-0.001260	-0.001261	-0.001767	-0.002803	-0.008584	-0.007061	-0.015272	-0.002254
6.00	0.64	-0.00972	-0.000697	-0.001102	-0.006764	-0.009382	-0.009782	-0.005170	-0.01682	-0.023073
5.25	0.75	-0.00831	-0.001359	-0.001184	-0.002967	-0.008239	-0.009452	-0.009452	-0.031074	-0.002445
4.50	1.00	-0.00591	-0.000697	-0.001291	-0.001491	-0.002988	-0.007358	-0.008228	-0.016776	-0.000780
4.25	1.25	-0.001271	-0.001226	-0.001266	-0.001809	-0.002588	-0.007177	-0.006949	-0.013497	-0.039089
4.00	1.50	-0.000449	-0.000705	-0.001266	-0.001361	-0.002764	-0.007151	-0.007662	-0.014073	-0.052261
13.00	1.50	-0.000205	-0.000231	-0.000413	-0.000912	-0.001785	-0.002474	-0.001197	-0.004734	-0.002165
11.00	1.50	-0.000325	-0.000201	-0.000443	-0.000978	-0.001675	-0.002470	-0.003920	-0.008934	-0.017143
9.00	1.50	-0.000325	-0.000292	-0.000633	-0.001469	-0.002363	-0.003238	-0.006003	-0.012160	-0.026589
7.25	1.50	-0.000946	-0.000641	-0.001382	-0.001629	-0.002442	-0.003459	-0.006239	-0.010673	-0.038690
5.25	1.50	-0.00302	-0.000375	-0.000664	-0.001263	-0.002442	-0.005465	-0.005822	-0.006148	-0.023745
3.50	1.50	-0.00072	-0.000106	-0.000522	-0.001121	-0.002442	-0.005465	-0.005822	-0.006148	-0.023745
2.00	1.50	-0.000146	-0.000046	-0.000522	-0.001121	-0.002442	-0.005465	-0.005822	-0.006148	-0.023745
-0.50	1.50	-0.000131	-0.000005	-0.000522	-0.001121	-0.002442	-0.005465	-0.005822	-0.006148	-0.023745
-2.00	1.50	-0.000191	-0.000035	-0.000416	-0.001100	-0.002023	-0.004147	-0.012064	-0.021361	-0.032586
-3.50	1.50	-0.000317	-0.000154	-0.000819	-0.002013	-0.008727	-0.010277	-0.008937	-0.009648	-0.017748
-4.50	1.50	-0.000317	-0.000154	-0.000819	-0.002013	-0.008727	-0.010277	-0.008937	-0.009648	-0.017748
-6.00	1.50	-0.000317	-0.000154	-0.000819	-0.002013	-0.008727	-0.010277	-0.008937	-0.009648	-0.017748
-7.50	1.50	-0.000317	-0.000154	-0.000819	-0.002013	-0.008727	-0.010277	-0.008937	-0.009648	-0.017748
-8.50	1.50	-0.000317	-0.000154	-0.000819	-0.002013	-0.008727	-0.010277	-0.008937	-0.009648	-0.017748
-9.50	1.50	-0.000317	-0.000154	-0.000819	-0.002013	-0.008727	-0.010277	-0.008937	-0.009648	-0.017748
-10.50	1.50	-0.000317	-0.000154	-0.000819	-0.002013	-0.008727	-0.010277	-0.008937	-0.009648	-0.017748
-11.50	1.50	-0.000317	-0.000154	-0.000819	-0.002013	-0.008727	-0.010277	-0.008937	-0.009648	-0.017748

Point	1	2	3	4	5	7	8	9	10	11
Total Thrust =	33.89	17.66	11.78	8.83	5.86	3.50	2.33	1.77	1.17	5.89
NPR Front =	51.61	51.38	51.22	51.23	51.17	51.16	51.15	51.16	51.16	51.23
NPR Aft =	2.06	2.05	2.04	2.04	2.04	2.04	2.04	2.04	2.04	2.04
X-loc	1.98	1.98	1.98	1.98	1.98	1.98	1.98	1.98	1.98	1.98
Y-loc	ACP	ACP	ACP	ACP	ACP	ACP	ACP	ACP	ACP	ACP
-10.00	-0.000343	-0.000440	-0.000669	-0.000284	-0.001772	-0.002730	-0.004052	-0.008294	-0.025517	-0.001345
-11.50	-0.000227	-0.000309	-0.000634	-0.000451	-0.000792	-0.001988	-0.003722	-0.008957	-0.032892	-0.000716
5.25	-0.000741	-0.000907	-0.001821	-0.001340	-0.003040	-0.005980	-0.009424	-0.017732	-0.034216	-0.003269
4.50	1.75	-0.000338	-0.000559	-0.000844	-0.001206	-0.002773	-0.004563	-0.008750	-0.033640	-0.002527
6.00	1.88	-0.001593	-0.003131	-0.001929	-0.002434	-0.005054	-0.008841	-0.013303	-0.020144	-0.004882
5.25	2.00	-0.001387	-0.000580	-0.001132	-0.001771	-0.003700	-0.009755	-0.013967	-0.018891	-0.003765
4.50	2.00	-0.000848	-0.000585	-0.000887	-0.001629	-0.002781	-0.004670	-0.006917	-0.010505	-0.002782
11.00	3.00	-0.000441	-0.000252	-0.000503	-0.001073	-0.001776	-0.003183	-0.005108	-0.011054	-0.002329
9.00	3.00	-0.000445	-0.000250	-0.000503	-0.001073	-0.001776	-0.003183	-0.005108	-0.011054	-0.002329
7.50	3.00	-0.000175	-0.000202	-0.000387	-0.001456	-0.002838	-0.004237	-0.007150	-0.011558	-0.002058
6.00	3.00	-0.000240	-0.000378	-0.000977	-0.001301	-0.002540	-0.004301	-0.007459	-0.012444	-0.002756
4.50	3.00	-0.000265	-0.000322	-0.000728	-0.001154	-0.002389	-0.004301	-0.007459	-0.012444	-0.002756
3.50	3.00	-0.000070	-0.000106	-0.000502	-0.001121	-0.002513	-0.004301	-0.007459	-0.012444	-0.002756
2.00	3.00	-0.000272	-0.000228	-0.000588	-0.000994	-0.002452	-0.004301	-0.007459	-0.012444	-0.002756
0.50	3.00	-0.000272	-0.000228	-0.000588	-0.000994	-0.002452	-0.004301	-0.007459	-0.012444	-0.002756
-2.00	3.00	-0.000297	-0.000132	-0.000537	-0.001045	-0.001797	-0.003020	-0.004642	-0.005689	-0.002523
-3.50	3.00	-0.00192	-0.00020	-0.000421	-0.000898	-0.001661	-0.002608	-0.004288	-0.005689	-0.002523
-4.50	3.00	-0.00183	-0.00051	-0.000395	-0.000857	-0.001117	-0.002081	-0.003366	-0.004568	-0.002393
-6.00	3.00	-0.00161	-0.00162	-0.000563	-0.000451	-0.000759	-0.001336	-0.002136	-0.003136	-0.001929
-7.50	3.00	-0.00161	-0.00162	-0.000563	-0.000451	-0.000759	-0.001336	-0.002136	-0.003136	-0.001929
-8.50	3.00	-0.00227	-0.000481	-0.000593	-0.000512	-0.0002020	-0.003548	-0.005293	-0.007433	-0.002138
-10.00	3.00	-0.00257	-0.000390	-0.000593	-0.000380	-0.001355	-0.002943	-0.004001	-0.005392	-0.001640
-11.50	3.00	-0.00176	-0.000380	-0.000694	-0.000431	-0.000609	-0.001175	-0.001778	-0.002480	-0.000680
8.00	5.00	-0.00040	-0.00020	-0.000171	-0.000103	-0.000241	-0.000411	-0.000427	-0.000496	-0.000193
4.00	5.00	-0.00055	-0.00055	-0.000811	-0.000842	-0.002164	-0.003257	-0.004486	-0.006072	-0.001927
2.00	5.00	-0.00035	-0.00091	-0.00111	-0.000942	-0.002114	-0.003257	-0.004486	-0.006072	-0.001927
0.00	5.00	-0.00040	-0.00096	-0.00151	-0.000933	-0.002476	-0.003554	-0.004827	-0.006374	-0.001957
-2.00	5.00	-0.00010	-0.00096	-0.00151	-0.000933	-0.002476	-0.003554	-0.004827	-0.006374	-0.001957
-4.00	5.00	0.00000	-0.00111	-0.00045	-0.000796	-0.000449	-0.000586	-0.000784	-0.001274	-0.001109
-6.00	5.00	-0.00025	-0.00111	-0.00050	-0.000761	-0.000313	-0.000518	-0.000470	-0.000537	-0.000767
-8.00	5.00	-0.00105	-0.00015	-0.00059	-0.000247	-0.001145	-0.002556	-0.003929	-0.005300	-0.002028
-10.00	5.00	-0.00140	-0.00010	-0.00054	-0.000841	-0.001145	-0.002556	-0.003929	-0.005300	-0.001155
5.50	6.00	-0.00150	-0.00106	-0.000735	-0.001043	-0.001866	-0.002638	-0.004036	-0.005300	-0.001872
2.00	7.00	-0.00240	-0.00050	-0.000735	-0.001043	-0.001866	-0.002638	-0.004036	-0.005300	-0.002444
-2.00	7.00	-0.00075	-0.00040	-0.000503	-0.000867	-0.000388	-0.000535	-0.000520	-0.000202	-0.000555
-6.00	7.00	-0.00180	-0.00040	-0.000473	-0.000585	-0.001240	-0.001414	-0.002581	-0.004541	-0.001049
-9.60	7.00	-0.00235	-0.00040	-0.000473	-0.000585	-0.001240	-0.001414	-0.002581	-0.004541	-0.001049
-2.00	8.00	-0.00265	-0.000322	-0.000498	-0.001245	-0.001776	-0.000288	-0.000338	-0.000349	-0.000224
-2.00	9.00	-0.00275	-0.000297	-0.000649	-0.000998	-0.000300	-0.000300	-0.000300	-0.000300	-0.000300
-6.00	9.00	-0.00190	-0.000201	-0.000388	-0.000643	-0.001044	-0.001055	-0.002470	-0.004845	-0.000743
-9.20	9.00	-0.00346	-0.000352	-0.000609	-0.000242	-0.000379	-0.000320	-0.000514	-0.000557	-0.000743
-2.00	10.00	-0.00481	-0.000473	-0.000564	-0.000796	-0.000373	-0.000262	-0.000363	-0.000192	-0.000166
-2.00	11.00	-0.00340	-0.000428	-0.000514	-0.000652	-0.000267	-0.000489	-0.000274	-0.000203	-0.000152
-6.00	11.00	-0.00200	-0.000327	-0.000488	-0.000151	-0.000525	-0.001303	-0.002192	-0.003274	-0.000378
-6.00	12.00	-0.00210	-0.000272	-0.000483	-0.000494	-0.000525	-0.001737	-0.002096	-0.002208	-0.000978
-8.60	12.00	-0.00275	-0.000252	-0.000373	-0.000428	-0.000530	-0.001545	-0.001859	-0.000051	-0.000570

Force and Moment Summary  
 Balance h/Ds = 33.89  
 Balance AL/T = -0.024  
 Balance AL/T = -0.021  
 Balance AM/TDs = 0.027  
 Balance AM/TDs = 0.018

Jet-Induced Pressure Increments  
Run 272

Point	33.90	17.67	11.77	8.83	5.87	4.70	3.53	1.75
h/De =	135.05	135.13	135.27	135.35	136.35	136.33	136.38	136.36
Total Thrust =	4.03	4.05	4.06	4.06	4.06	4.06	4.07	4.07
NPR Front =	3.97	3.96	3.96	3.96	4.01	4.01	4.00	4.00
NPR Aft =	ACP	ACP	ACP	ACP	ACP	ACP	ACP	ACP
X-loc	Y-loc	Y-loc	Y-loc	Y-loc	Y-loc	Y-loc	Y-loc	Y-loc
6.00	-0.000509	-0.004337	-0.002202	-0.004825	-0.005838	-0.008392	-0.009756	0.005023
6.00	-0.000267	-0.000247	-0.002426	-0.004012	-0.004795	-0.006518	-0.007656	0.003564
6.00	-0.000750	-0.000324	-0.000998	-0.003664	-0.004090	-0.005271	-0.005799	0.003532
6.00	-0.000318	-0.000183	-0.001245	-0.003074	-0.003238	-0.004214	-0.005340	0.006611
17.00	0.00	-0.000072	-0.000153	-0.000356	-0.000538	-0.000762	-0.001071	0.000184
15.00	0.00	-0.000022	-0.000210	-0.000430	-0.000504	-0.000720	-0.000948	0.000256
13.00	0.00	-0.000084	-0.000237	-0.000338	-0.000358	-0.000567	-0.000765	0.000216
9.00	0.00	-0.000084	-0.000252	-0.000288	-0.000258	-0.000172	-0.000127	0.000216
7.50	0.00	-0.000097	-0.000218	-0.000189	-0.000122	-0.000118	-0.000081	0.000216
6.75	0.00	-0.000098	-0.000218	-0.000189	-0.000122	-0.000118	-0.000081	0.000216
6.00	0.00	-0.000024	-0.000074	-0.000154	-0.000216	-0.000270	-0.000324	0.000388
4.50	0.00	-0.000042	-0.000139	-0.000221	-0.000270	-0.000324	-0.000388	0.000452
3.75	0.00	-0.000198	-0.000329	-0.000490	-0.000639	-0.000813	-0.000999	0.001194
2.50	0.00	-0.000135	-0.000239	-0.000349	-0.000443	-0.000538	-0.000633	0.000728
2.00	0.00	-0.000096	-0.000168	-0.000240	-0.000312	-0.000384	-0.000456	0.000528
1.25	0.00	-0.000033	-0.000074	-0.000115	-0.000156	-0.000197	-0.000238	0.000279
-0.50	0.00	-0.000014	-0.000033	-0.000052	-0.000071	-0.000090	-0.000109	0.000128
-1.25	0.00	-0.000014	-0.000033	-0.000052	-0.000071	-0.000090	-0.000109	0.000128
-2.00	0.00	-0.000014	-0.000033	-0.000052	-0.000071	-0.000090	-0.000109	0.000128
-2.75	0.00	-0.000014	-0.000033	-0.000052	-0.000071	-0.000090	-0.000109	0.000128
-3.50	0.00	-0.000014	-0.000033	-0.000052	-0.000071	-0.000090	-0.000109	0.000128
-4.15	0.00	-0.000014	-0.000033	-0.000052	-0.000071	-0.000090	-0.000109	0.000128
-4.50	0.00	-0.000014	-0.000033	-0.000052	-0.000071	-0.000090	-0.000109	0.000128
-4.85	0.00	-0.000014	-0.000033	-0.000052	-0.000071	-0.000090	-0.000109	0.000128
-5.20	0.00	-0.000014	-0.000033	-0.000052	-0.000071	-0.000090	-0.000109	0.000128
-6.00	0.00	-0.000014	-0.000033	-0.000052	-0.000071	-0.000090	-0.000109	0.000128
-7.15	0.00	-0.000014	-0.000033	-0.000052	-0.000071	-0.000090	-0.000109	0.000128
-7.85	0.00	-0.000014	-0.000033	-0.000052	-0.000071	-0.000090	-0.000109	0.000128
-8.50	0.00	-0.000014	-0.000033	-0.000052	-0.000071	-0.000090	-0.000109	0.000128
-9.25	0.00	-0.000014	-0.000033	-0.000052	-0.000071	-0.000090	-0.000109	0.000128
-10.00	0.00	-0.000014	-0.000033	-0.000052	-0.000071	-0.000090	-0.000109	0.000128
-10.75	0.00	-0.000014	-0.000033	-0.000052	-0.000071	-0.000090	-0.000109	0.000128
-11.50	0.00	-0.000014	-0.000033	-0.000052	-0.000071	-0.000090	-0.000109	0.000128
6.00	0.16	-0.000366	-0.000852	-0.001147	-0.001413	-0.001679	-0.001945	0.002211
5.25	0.25	-0.000439	-0.000593	-0.000757	-0.000921	-0.001085	-0.001249	0.001413
4.50	0.32	-0.000442	-0.000595	-0.000759	-0.000923	-0.001087	-0.001251	0.001415
6.00	0.48	-0.000623	-0.000932	-0.001239	-0.001546	-0.001853	-0.002160	0.002467
5.25	0.50	-0.000548	-0.000674	-0.000800	-0.000926	-0.001052	-0.001178	0.001304
4.50	0.64	-0.000702	-0.001207	-0.001712	-0.002217	-0.002722	-0.003227	0.003732
5.25	0.75	-0.000875	-0.001295	-0.001784	-0.002273	-0.002762	-0.003251	0.003740
4.50	1.00	-0.000458	-0.001130	-0.001519	-0.001908	-0.002297	-0.002686	0.003075
5.25	1.25	-0.000321	-0.000620	-0.000839	-0.001058	-0.001277	-0.001496	0.001715
5.25	1.25	-0.000859	-0.001184	-0.001509	-0.001834	-0.002159	-0.002484	0.002809
4.50	1.50	-0.000401	-0.000626	-0.000851	-0.001076	-0.001301	-0.001526	0.001751
13.00	1.50	-0.000109	-0.000277	-0.000445	-0.000613	-0.000781	-0.000949	0.001117
9.00	1.50	-0.000065	-0.000266	-0.000420	-0.000574	-0.000728	-0.000882	0.001036
11.00	1.50	-0.000059	-0.000237	-0.000391	-0.000545	-0.000699	-0.000853	0.001007
7.50	1.50	-0.000206	-0.000626	-0.000931	-0.001236	-0.001541	-0.001846	0.002151
5.25	1.50	-0.000604	-0.001248	-0.001921	-0.002594	-0.003267	-0.003940	0.004613
4.50	1.50	-0.000321	-0.000513	-0.000705	-0.000897	-0.001089	-0.001281	0.001473
3.50	1.50	-0.000246	-0.000343	-0.000440	-0.000537	-0.000634	-0.000731	0.000828
2.00	1.50	-0.000246	-0.000343	-0.000440	-0.000537	-0.000634	-0.000731	0.000828
0.50	1.50	-0.000089	-0.000187	-0.000284	-0.000381	-0.000478	-0.000575	0.000672
-0.50	1.50	-0.000044	-0.000089	-0.000134	-0.000179	-0.000224	-0.000269	0.000314
-2.00	1.50	-0.000029	-0.000058	-0.000087	-0.000116	-0.000145	-0.000174	0.000203
-3.50	1.50	-0.000029	-0.000058	-0.000087	-0.000116	-0.000145	-0.000174	0.000203
-4.50	1.50	-0.000029	-0.000058	-0.000087	-0.000116	-0.000145	-0.000174	0.000203
-6.00	1.50	-0.000029	-0.000058	-0.000087	-0.000116	-0.000145	-0.000174	0.000203
-7.50	1.50	-0.000029	-0.000058	-0.000087	-0.000116	-0.000145	-0.000174	0.000203
-8.50	1.50	-0.000029	-0.000058	-0.000087	-0.000116	-0.000145	-0.000174	0.000203

Force and Moment Summary

Balance	h/De = 33.90	17.67	11.77	8.83	5.87	4.70	3.53	1.75
Pressure	AL/T = -0.017	-0.027	-0.049	-0.081	-0.113	-0.155	-0.257	-0.535
Pressure	AM/T = -0.007	-0.030	-0.049	-0.076	-0.102	-0.132	-0.250	-0.535
Pressure	AN/TDe = 0.007	0.015	0.015	-0.031	-0.078	-0.229	-0.535	-0.535
Pressure	AM/TDe = 0.017	0.022	0.020	-0.039	-0.218	0.272	0.278	0.790



Jet-Induced Pressure Increments  
 Configuration: 3C-12.2.5-DM Run 273

Point	1	2	3	4	5	6	7	8
h/De =	17.66	11.77	8.83	5.87	4.70	3.52	2.70	3.54
Total Thrust =	221.17	221.17	221.03	220.88	220.83	220.75	220.68	220.68
NPR Front =	6.08	6.08	6.07	6.07	6.07	6.07	6.07	6.07
NPR Aft =	5.98	5.98	5.97	5.97	5.97	5.97	5.97	5.96
X-loc	ACP	ACP	ACP	ACP	ACP	ACP	ACP	ACP
Y-loc	ACP	ACP	ACP	ACP	ACP	ACP	ACP	ACP
1.50	-0.00242	-0.00389	-0.00440	-0.00485	-0.00531	-0.00577	-0.00623	-0.00669
1.50	-0.00031	-0.00031	-0.00031	-0.00031	-0.00031	-0.00031	-0.00031	-0.00031
1.75	-0.00049	-0.00078	-0.00107	-0.00136	-0.00165	-0.00194	-0.00223	-0.00252
1.75	-0.00035	-0.00035	-0.00035	-0.00035	-0.00035	-0.00035	-0.00035	-0.00035
1.75	-0.00067	-0.00067	-0.00067	-0.00067	-0.00067	-0.00067	-0.00067	-0.00067
17.00	0.000125	0.00031	0.00051	0.00071	0.00091	0.00111	0.00131	0.00151
13.00	0.000152	0.00036	0.00057	0.00078	0.00099	0.00120	0.00141	0.00162
9.00	0.000254	0.00056	0.00087	0.00118	0.00149	0.00180	0.00211	0.00242
6.75	0.000377	0.00079	0.00121	0.00163	0.00205	0.00247	0.00289	0.00331
5.25	0.000491	0.00092	0.00135	0.00178	0.00221	0.00264	0.00307	0.00350
4.50	0.000598	0.00103	0.00147	0.00191	0.00235	0.00279	0.00323	0.00367
3.50	0.000712	0.00116	0.00161	0.00206	0.00251	0.00296	0.00341	0.00386
2.75	0.000826	0.00129	0.00176	0.00223	0.00270	0.00317	0.00364	0.00411
2.00	0.000940	0.00142	0.00190	0.00238	0.00286	0.00334	0.00382	0.00430
1.25	0.001054	0.00154	0.00203	0.00252	0.00301	0.00350	0.00399	0.00448
0.50	0.001168	0.00167	0.00218	0.00269	0.00320	0.00371	0.00422	0.00473
1.25	0.001282	0.00180	0.00232	0.00284	0.00336	0.00388	0.00440	0.00492
1.25	0.001396	0.00192	0.00245	0.00297	0.00350	0.00403	0.00456	0.00509
1.25	0.001510	0.00204	0.00257	0.00310	0.00363	0.00416	0.00469	0.00522
1.25	0.001624	0.00217	0.00271	0.00324	0.00377	0.00430	0.00483	0.00536
1.25	0.001738	0.00229	0.00283	0.00336	0.00389	0.00442	0.00495	0.00548
1.25	0.001852	0.00241	0.00295	0.00348	0.00401	0.00454	0.00507	0.00560
1.25	0.001966	0.00253	0.00307	0.00360	0.00413	0.00466	0.00519	0.00572
1.25	0.002080	0.00260	0.00314	0.00367	0.00420	0.00473	0.00526	0.00579
1.25	0.002194	0.00272	0.00326	0.00379	0.00432	0.00485	0.00538	0.00591
1.25	0.002308	0.00283	0.00337	0.00390	0.00443	0.00496	0.00549	0.00602
1.25	0.002422	0.00295	0.00349	0.00402	0.00455	0.00508	0.00561	0.00614
1.25	0.002536	0.00306	0.00360	0.00413	0.00466	0.00519	0.00572	0.00625
1.25	0.002650	0.00318	0.00372	0.00425	0.00478	0.00531	0.00584	0.00637
1.25	0.002764	0.00329	0.00383	0.00436	0.00489	0.00542	0.00595	0.00648
1.25	0.002878	0.00341	0.00394	0.00447	0.00500	0.00553	0.00606	0.00659
1.25	0.002992	0.00352	0.00406	0.00459	0.00512	0.00565	0.00618	0.00671
1.25	0.003106	0.00364	0.00417	0.00470	0.00523	0.00576	0.00629	0.00682
1.25	0.003220	0.00375	0.00428	0.00481	0.00534	0.00587	0.00640	0.00693
1.25	0.003334	0.00387	0.00440	0.00493	0.00546	0.00599	0.00652	0.00705
1.25	0.003448	0.00398	0.00451	0.00504	0.00557	0.00610	0.00663	0.00716
1.25	0.003562	0.00410	0.00463	0.00516	0.00569	0.00622	0.00675	0.00728
1.25	0.003676	0.00421	0.00474	0.00527	0.00580	0.00633	0.00686	0.00739
1.25	0.003790	0.00432	0.00485	0.00538	0.00591	0.00644	0.00697	0.00750
1.25	0.003904	0.00443	0.00496	0.00549	0.00602	0.00655	0.00708	0.00761
1.25	0.004018	0.00454	0.00507	0.00560	0.00613	0.00666	0.00719	0.00772
1.25	0.004132	0.00465	0.00518	0.00571	0.00624	0.00677	0.00730	0.00783
1.25	0.004246	0.00477	0.00530	0.00583	0.00636	0.00689	0.00742	0.00795
1.25	0.004360	0.00489	0.00542	0.00595	0.00648	0.00701	0.00754	0.00807
1.25	0.004474	0.00500	0.00553	0.00606	0.00659	0.00712	0.00765	0.00818
1.25	0.004588	0.00511	0.00564	0.00617	0.00670	0.00723	0.00776	0.00829
1.25	0.004702	0.00523	0.00576	0.00631	0.00684	0.00737	0.00790	0.00843
1.25	0.004816	0.00534	0.00587	0.00642	0.00695	0.00748	0.00801	0.00854
1.25	0.004930	0.00545	0.00598	0.00656	0.00709	0.00762	0.00815	0.00868
1.25	0.005044	0.00556	0.00609	0.00668	0.00721	0.00774	0.00827	0.00880
1.25	0.005158	0.00567	0.00620	0.00680	0.00733	0.00786	0.00839	0.00892
1.25	0.005272	0.00579	0.00632	0.00692	0.00745	0.00798	0.00851	0.00904
1.25	0.005386	0.00590	0.00643	0.00703	0.00756	0.00809	0.00862	0.00915
1.25	0.005500	0.00602	0.00655	0.00715	0.00768	0.00821	0.00874	0.00927
1.25	0.005614	0.00613	0.00666	0.00728	0.00781	0.00834	0.00887	0.00940
1.25	0.005728	0.00624	0.00677	0.00740	0.00793	0.00846	0.00899	0.00952
1.25	0.005842	0.00636	0.00689	0.00751	0.00804	0.00857	0.00910	0.00963
1.25	0.005956	0.00647	0.00700	0.00763	0.00816	0.00869	0.00922	0.00975
1.25	0.006070	0.00658	0.00711	0.00774	0.00827	0.00880	0.00933	0.00986
1.25	0.006184	0.00669	0.00722	0.00785	0.00838	0.00891	0.00944	0.00997
1.25	0.006298	0.00680	0.00733	0.00796	0.00849	0.00902	0.00955	0.01008
1.25	0.006412	0.00691	0.00745	0.00808	0.00861	0.00914	0.00967	0.01020
1.25	0.006526	0.00702	0.00756	0.00819	0.00872	0.00925	0.00978	0.01031
1.25	0.006640	0.00713	0.00767	0.00830	0.00883	0.00936	0.00989	0.01042
1.25	0.006754	0.00724	0.00778	0.00841	0.00894	0.00947	0.01000	0.01053
1.25	0.006868	0.00735	0.00789	0.00852	0.00905	0.00958	0.01011	0.01064
1.25	0.006982	0.00746	0.00800	0.00863	0.00916	0.00969	0.01022	0.01075
1.25	0.007096	0.00757	0.00811	0.00874	0.00927	0.00980	0.01033	0.01086
1.25	0.007210	0.00769	0.00823	0.00886	0.00939	0.00992	0.01045	0.01098
1.25	0.007324	0.00780	0.00834	0.00897	0.00950	0.01003	0.01056	0.01109
1.25	0.007438	0.00791	0.00845	0.00908	0.00961	0.01014	0.01067	0.01120
1.25	0.007552	0.00802	0.00856	0.00919	0.00972	0.01025	0.01078	0.01131
1.25	0.007666	0.00813	0.00867	0.00930	0.00983	0.01036	0.01089	0.01142
1.25	0.007780	0.00824	0.00878	0.00945	0.00998	0.01051	0.01104	0.01157
1.25	0.007894	0.00835	0.00889	0.00956	0.01009	0.01062	0.01115	0.01168
1.25	0.008008	0.00846	0.00900	0.00967	0.01020	0.01073	0.01126	0.01179
1.25	0.008122	0.00857	0.00911	0.00978	0.01031	0.01084	0.01137	0.01190
1.25	0.008236	0.00868	0.00922	0.00989	0.01042	0.01095	0.01148	0.01201
1.25	0.008350	0.00880	0.00934	0.01001	0.01054	0.01107	0.01160	0.01213
1.25	0.008464	0.00891	0.00945	0.01012	0.01065	0.01118	0.01171	0.01224
1.25	0.008578	0.00902	0.00956	0.01023	0.01076	0.01129	0.01182	0.01235
1.25	0.008692	0.00913	0.00967	0.01034	0.01087	0.01140	0.01193	0.01246
1.25	0.008806	0.00924	0.00978	0.01045	0.01098	0.01151	0.01204	0.01257
1.25	0.008920	0.00935	0.00989	0.01056	0.01109	0.01162	0.01215	0.01268
1.25	0.009034	0.00946	0.01000	0.01067	0.01120	0.01173	0.01226	0.01279
1.25	0.009148	0.00957	0.01011	0.01072	0.01125	0.01178	0.01231	0.01284
1.25	0.009262	0.00969	0.01016	0.01077	0.01130	0.01183	0.01236	0.01289
1.25	0.009376	0.00980	0.01027	0.01088	0.01141	0.01194	0.01247	0.01300
1.25	0.009490	0.00991	0.01038	0.01099	0.01152	0.01205	0.01258	0.01311
1.25	0.009604	0.01002	0.01049	0.01110	0.01163	0.01216	0.01269	0.01322
1.25	0.009718	0.01013	0.01060	0.01121	0.01174	0.01227	0.01280	0.01333
1.25	0.009832	0.01024	0.01071	0.01132	0.01185	0.01238	0.01291	0.01344
1.25	0.009946	0.01035	0.01082	0.01143	0.01196	0.01249	0.01302	0.01355
1.25	0.010060	0.01046	0.01093	0.01154	0.01207	0.01260	0.01313	0.01366
1.25	0.010174	0.01057	0.01104	0.01165	0.01218	0.01271	0.01324	0.01377
1.25	0.010288	0.01068	0.01115	0.01176				

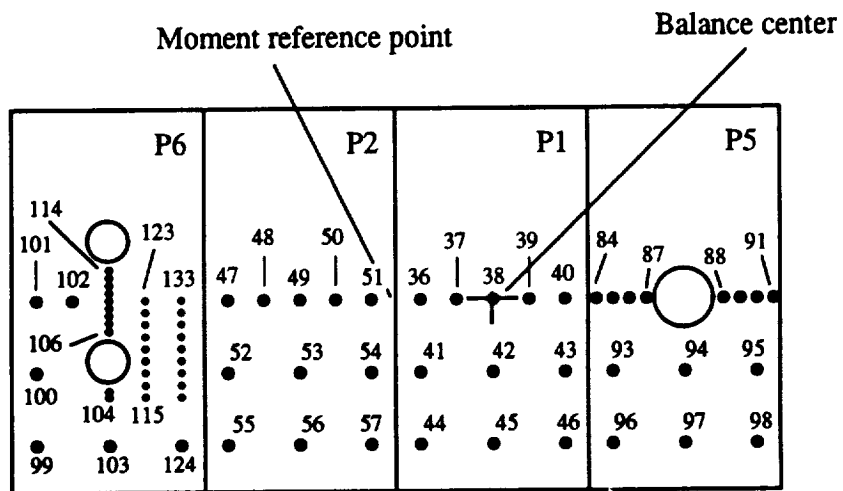

Figure 76. Configuration 3C\_12\_2.5\_16/8;  $D_e = 1.699$  in.,  $A_{jet} = 2.27$  in.<sup>2</sup>.

## Pressure Orifice Locations and Weighting Factors

Conf. # 3C-12-2.5-16/8

Distance from balance center to moment reference point,  $X_0 = 2$

Orif. #	Mom. arm	Sta. y	$\Delta$ .Area	Sta. x
99	7.5	3	4.688	7.5
100	7.165	1.5	4.38	7.5
101	7.5	0	1.313	7.5
102	6.75	0	1.125	6.75
103	6	3	5.625	6
104	6	2	0.278	6
105	6	1.88	0.38	6
106	6	0.64	0.38	6
107	6	0.48	0.24	6
108	6	0.32	0.24	6
109	6	0.16	0.24	6
110	6	0	0.12	6
111	6	-0.16	0	6
112	6	-0.32	0	6
113	6	-0.48	0	6
114	6	-0.64	0	6
115	5.25	2	0.375	5.25
116	5.25	1.75	0.375	5.25
117	5.25	1.5	0.355	5.25
118	5.25	1.25	0.325	5.25
119	5.25	1	0.355	5.25
120	5.25	0.75	0.375	5.25
121	5.25	0.5	0.375	5.25
122	5.25	0.25	0.375	5.25
123	5.25	0	0.188	5.25
124	4.5	3	4.688	4.5
125	4.5	2	0.438	4.5
126	4.5	1.75	0.438	4.5
127	4.5	1.5	0.438	4.5
128	4.5	1.25	0.438	4.5
129	4.5	1	0.438	4.5
130	4.5	0.75	0.438	4.5
131	4.5	0.5	0.438	4.5
132	4.5	0.25	0.438	4.5
133	4.5	0	0.219	4.5
47	3.5	0	1.313	3.5
48	2.75	0	1.125	2.75
49	2	0	1.125	2
50	1.25	0	1.125	1.25
51	0.5	0	1.313	0.5
52	3.5	1.5	3.75	3.5
53	2	1.5	4.5	2
54	0.5	1.5	3.75	0.5
55	3.5	3	4.375	3.5
56	2	3	5.25	2
57	0.5	3	4.375	0.5

Conf. # 3C\_12\_2.5\_16/8, continued

Orif. #	Mom. arm	Sta. y	Δ.Area	Sta. x
36	-0.5	0	1.313	-0.5
37	-1.25	0	1.125	-1.25
38	-2	0	1.125	-2
39	-2.75	0	1.125	-2.75
40	-3.5	0	1.313	-3.5
41	-0.5	1.5	3.75	-0.5
42	-2	1.5	4.5	-2
43	-3.5	1.5	3.75	-3.5
44	-0.5	3	4.375	-0.5
45	-2	3	5.25	-2
46	-3.5	3	4.375	-3.5
84	-4.15	0	0.634	-4.15
85	-4.5	0	0.683	-4.5
86	-4.85	0	0.683	-4.85
87	-5.2	0	0.619	-5.2
88	-6.8	0	0.619	-6.8
89	-7.15	0	0.683	-7.15
90	-7.5	0	0.683	-7.5
91	-7.85	0	0.634	-7.85
93	-4.5	1.5	3.19	-4.5
94	-6	1.5	5.062	-6
95	-7.5	1.5	3.19	-7.5
96	-4.5	3	4.375	-4.5
97	-6	3	5.25	-6
98	-7.5	3	4.375	-7.5

Point	1	2	3	4	5	6	7	8	9	10
Total Thrust =	33.88	17.66	11.77	8.82	5.87	4.69	3.53	2.32	1.75	1.14
NPR Front =	52.05	51.09	51.21	51.13	51.05	51.04	51.04	51.07	51.08	51.07
NPR Aft =	2.06	2.04	2.04	2.04	2.03	2.03	2.03	2.03	2.03	2.03
X-loc	2.01	1.98	1.99	1.99	1.98	1.98	1.99	1.99	1.99	1.99
Y-loc	ACP	ACP	ACP	ACP	ACP	ACP	ACP	ACP	ACP	ACP
0.00	-0.001261	-0.001501	-0.002071	-0.001815	-0.006816	-0.006856	-0.008164	-0.004499	-0.000329	0.013679
6.00	-0.001032	-0.001501	-0.002071	-0.001685	-0.004631	-0.005978	-0.006874	-0.005468	-0.001371	0.017895
6.00	-0.000985	-0.001025	-0.001044	-0.001348	-0.003726	-0.005134	-0.005039	-0.003041	0.001964	0.031854
6.00	-0.000607	-0.000683	-0.000777	-0.001521	-0.003627	-0.005025	-0.005048	-0.004221	0.007486	0.041952
7.50	0.00	-0.000565	-0.001161	-0.001383	-0.001130	-0.001446	-0.001498	-0.001916	0.004653	0.077922
6.75	0.00	-0.000543	-0.000502	-0.000768	-0.001957	-0.001809	-0.001810	-0.003765	0.009337	0.031748
6.00	-0.000930	-0.000757	-0.000967	-0.001828	-0.003323	-0.004654	-0.004958	-0.004895	0.007348	0.024091
5.25	0.00	-0.000845	-0.000930	-0.001325	-0.003830	-0.005117	-0.005158	-0.004818	0.004451	0.054012
3.50	0.00	-0.000445	-0.000480	-0.001122	-0.002783	-0.004878	-0.004878	-0.004227	-0.000561	0.021586
2.75	0.00	-0.000265	-0.000153	-0.000432	-0.002680	-0.003068	-0.003068	-0.003427	-0.000576	0.006066
2.00	0.00	-0.000390	-0.000142	-0.000572	-0.001934	-0.003120	-0.003120	-0.003336	-0.000510	0.005046
1.25	0.00	-0.000270	-0.000234	-0.000335	-0.000991	-0.001865	-0.001865	-0.002091	-0.000557	0.004012
0.50	0.00	-0.000120	-0.000117	-0.000630	-0.001930	-0.003146	-0.003146	-0.003269	-0.000525	0.003154
-0.25	0.00	-0.000015	-0.000061	-0.000381	-0.000773	-0.002707	-0.002707	-0.002699	-0.000512	0.003484
-1.00	0.00	-0.000030	-0.000026	-0.000264	-0.000860	-0.002539	-0.002539	-0.002508	-0.000512	0.003484
-1.75	0.00	-0.000140	-0.000016	-0.000203	-0.001125	-0.002948	-0.002948	-0.002948	-0.000512	0.003484
-2.50	0.00	-0.000370	-0.000158	-0.000498	-0.001595	-0.003244	-0.003244	-0.003244	-0.000512	0.003484
-3.25	0.00	-0.000740	-0.000317	-0.000849	-0.002532	-0.004546	-0.004546	-0.004546	-0.000512	0.003484
-4.00	0.00	-0.001490	-0.000624	-0.001328	-0.002583	-0.004818	-0.004818	-0.004818	-0.000512	0.003484
-4.75	0.00	-0.002790	-0.001167	-0.002323	-0.003885	-0.006464	-0.006464	-0.006464	-0.000512	0.003484
-5.50	0.00	-0.004790	-0.002069	-0.004723	-0.006282	-0.010147	-0.010147	-0.010147	-0.000512	0.003484
-6.25	0.00	-0.007505	-0.003528	-0.007525	-0.012532	-0.022132	-0.022132	-0.022132	-0.000512	0.003484
-7.00	0.00	-0.010250	-0.005120	-0.010272	-0.019249	-0.032544	-0.032544	-0.032544	-0.000512	0.003484
-7.75	0.00	-0.013410	-0.007024	-0.013428	-0.025744	-0.045156	-0.045156	-0.045156	-0.000512	0.003484
8.50	0.00	-0.000740	-0.000324	-0.000498	-0.001484	-0.002532	-0.002532	-0.002532	-0.000512	0.003484
9.25	0.00	-0.000887	-0.000672	-0.001348	-0.003458	-0.005118	-0.005118	-0.005118	-0.000512	0.003484
6.00	-0.001372	-0.000887	-0.001174	-0.001772	-0.004232	-0.006860	-0.006860	-0.006860	-0.000512	0.003484
6.00	-0.000253	-0.001167	-0.001416	-0.002132	-0.004744	-0.007592	-0.007592	-0.007592	-0.000512	0.003484
3.25	-0.000256	-0.000981	-0.001289	-0.001815	-0.003530	-0.005240	-0.005240	-0.005240	-0.000512	0.003484
6.00	-0.001456	-0.001561	-0.002235	-0.002906	-0.006838	-0.008700	-0.008700	-0.008700	-0.000512	0.003484
6.00	-0.001321	-0.000820	-0.001173	-0.001624	-0.004055	-0.006432	-0.006432	-0.006432	-0.000512	0.003484
3.25	-0.001123	-0.000662	-0.001100	-0.001214	-0.002614	-0.004363	-0.004363	-0.004363	-0.000512	0.003484
3.25	-0.000416	-0.000955	-0.001623	-0.001910	-0.003099	-0.004515	-0.004515	-0.004515	-0.000512	0.003484
3.25	-0.000317	-0.000280	-0.001133	-0.001389	-0.002885	-0.003766	-0.003766	-0.003766	-0.000512	0.003484
1.25	-0.001226	-0.000964	-0.001743	-0.001893	-0.002623	-0.003419	-0.003419	-0.003419	-0.000512	0.003484
1.50	-0.000840	-0.000705	-0.000878	-0.001194	-0.002679	-0.003309	-0.003309	-0.003309	-0.000512	0.003484
1.50	-0.000883	-0.000531	-0.001005	-0.001370	-0.002649	-0.003419	-0.003419	-0.003419	-0.000512	0.003484
1.50	-0.000465	-0.000311	-0.000397	-0.001318	-0.001824	-0.002818	-0.002818	-0.002818	-0.000512	0.003484
2.00	-0.000860	-0.000356	-0.000330	-0.001048	-0.002741	-0.004953	-0.004953	-0.004953	-0.000512	0.003484
-2.00	-0.000005	-0.000031	-0.000467	-0.001023	-0.003001	-0.004245	-0.004245	-0.004245	-0.000512	0.003484
-2.00	-0.000640	-0.000372	-0.000498	-0.000987	-0.002328	-0.003400	-0.003400	-0.003400	-0.000512	0.003484
-4.50	-0.000640	-0.000249	-0.000218	-0.000783	-0.001380	-0.001819	-0.001819	-0.001819	-0.000512	0.003484
-6.00	-0.000959	-0.001644	-0.001137	-0.002335	-0.009154	-0.12958	-0.09646	-0.06656	-0.06130	0.006928
-6.00	-0.000550	-0.001171	-0.001584	-0.001582	-0.002262	-0.003037	-0.003129	-0.002984	-0.003564	0.010661
5.25	-0.001079	-0.000839	-0.001726	-0.001542	-0.002501	-0.003791	-0.005238	-0.008267	-0.014926	0.026477
4.50	-0.000543	-0.000579	-0.000608	-0.001348	-0.002337	-0.003234	-0.003644	-0.007804	-0.014926	0.023815
6.00	-0.001138	-0.001418	-0.001554	-0.002143	-0.006470	-0.008211	-0.010056	-0.010192	-0.010561	0.014817
6.00	-0.000794	-0.001220	-0.001273	-0.001828	-0.004640	-0.005948	-0.008809	-0.010423	-0.010473	0.014124
5.25	-0.001006	-0.001056	-0.001385	-0.001392	-0.003142	-0.003653	-0.005363	-0.008167	-0.012637	0.023229
7.50	-0.000611	-0.000415	-0.001290	-0.001491	-0.002340	-0.003511	-0.005212	-0.007397	-0.012797	0.022528
3.00	-0.000374	-0.000458	-0.000587	-0.001093	-0.001385	-0.002013	-0.002018	-0.002673	-0.003590	0.004911
3.00	-0.000348	-0.000571	-0.000945	-0.001383	-0.002757	-0.004236	-0.004125	-0.004785	-0.007794	0.009882
3.50	-0.000860	-0.001164	-0.000930	-0.001206	-0.001926	-0.002160	-0.003212	-0.006416	-0.011663	0.014719
3.00	-0.000220	-0.000239	-0.000970	-0.001277	-0.000992	-0.002283	-0.004118	-0.006483	-0.008071	0.006743
3.00	-0.000575	-0.000473	-0.000279	-0.001094	-0.000326	-0.002604	-0.000647	-0.005536	-0.009688	0.013882
-2.00	-0.000570	-0.000473	-0.000858	-0.000962	-0.001157	-0.002316	-0.003827	-0.007292	-0.008279	0.009685

Point	1	2	3	4	5	6	7	8	9	10
h/De =	33.88	17.66	11.77	8.82	5.87	4.69	3.53	2.32	1.75	1.14
Total Thrust =	52.05	51.09	51.21	51.13	51.05	51.04	51.04	51.07	51.08	51.07
NPR Front =	2.06	2.04	2.04	2.04	2.03	2.03	2.03	2.03	2.03	2.03
NPR Aft =	2.01	1.98	1.99	1.99	1.98	1.98	1.99	1.99	1.99	1.99
X-loc	Y-loc	ACP	ACP	ACP	ACP	ACP	ACP	ACP	ACP	ACP
-3.50	3.00	-0.000450	-0.000433	-0.001549	-0.001221	-0.000428	-0.002339	-0.005188	-0.006575	-0.007470
-4.50	3.00	-0.000550	-0.001171	-0.001584	-0.001582	-0.002262	-0.003037	-0.003125	-0.002984	-0.003564
-6.00	3.00	-0.000480	-0.000463	-0.000554	-0.000845	-0.002226	-0.003537	-0.004169	-0.003916	-0.004872
-7.50	3.00	-0.000480	-0.000463	-0.000554	-0.000845	-0.002226	-0.003537	-0.004169	-0.003916	-0.004872

Force and Moment Summary

h/De =	33.88	17.66	11.77	8.82	5.87	4.69	3.53	2.32	1.75	1.14
Balance AL/T =	-0.013	-0.013	-0.020	-0.031	-0.017	-0.028	-0.054	-0.094	-0.131	-0.219
Pressure AL/T =	-0.015	-0.015	-0.024	-0.035	-0.027	-0.041	-0.056	-0.081	-0.108	-0.194
Balance AH/TDe =	-0.005	-0.004	0.001	0.002	-0.005	0.018	0.038	0.043	0.043	0.070
Pressure AH/TDe =	0.001	0.010	0.003	0.000	0.027	0.074	0.071	0.076	0.096	0.158







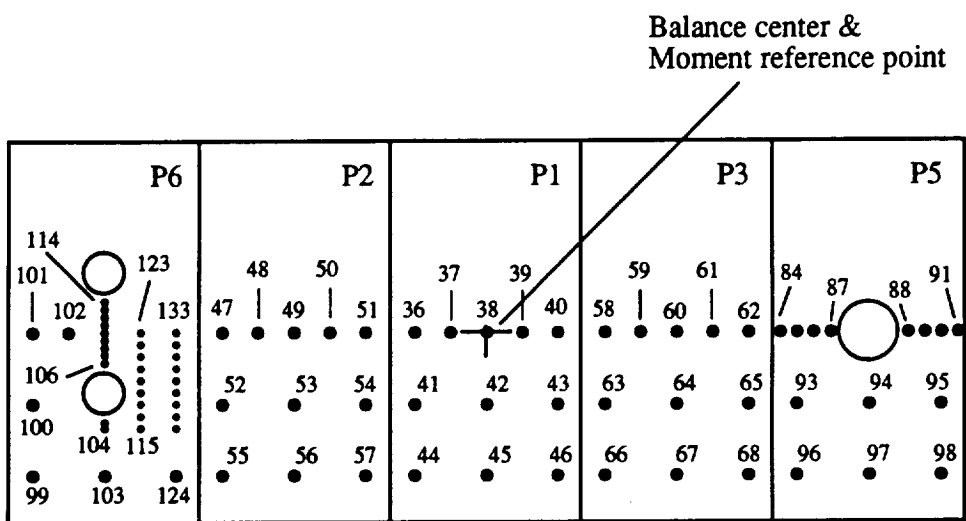

Figure 77. Configuration 3C\_16\_2.5\_20/8;  $D_e = 1.699$  in.,  $A_{jet} = 2.27$  in.<sup>2</sup>.

Pressure Orifice Locations and Weighting Factors

Conf. # 3C-16-2.5-20/8

Distance from balance center to moment reference point,  $X_0 = 0$

Orif. #	Mom. arm	Sta. y	$\Delta$ .Area	Sta. x
99	9.5	3	4.688	9.5
100	9.165	1.5	4.38	9.5
101	9.5	0	1.313	9.5
102	8.75	0	1.125	8.75
103	8	3	5.625	8
104	8	2	0.278	8
105	8	1.88	0.38	8
106	8	0.64	0.38	8
107	8	0.48	0.24	8
108	8	0.32	0.24	8
109	8	0.16	0.24	8
110	8	0	0.12	8
111	8	-0.16	0	8
112	8	-0.32	0	8
113	8	-0.48	0	8
114	8	-0.64	0	8
115	7.25	2	0.375	7.25
116	7.25	1.75	0.375	7.25
117	7.25	1.5	0.355	7.25
118	7.25	1.25	0.325	7.25
119	7.25	1	0.355	7.25
120	7.25	0.75	0.375	7.25
121	7.25	0.5	0.375	7.25
122	7.25	0.25	0.375	7.25
123	7.25	0	0.188	7.25
124	6.5	3	4.688	6.5
125	6.5	2	0.438	6.5
126	6.5	1.75	0.438	6.5
127	6.5	1.5	0.438	6.5
128	6.5	1.25	0.438	6.5
129	6.5	1	0.438	6.5
130	6.5	0.75	0.438	6.5
131	6.5	0.5	0.438	6.5
132	6.5	0.25	0.438	6.5
133	6.5	0	0.219	6.5
47	5.5	0	1.313	5.5
48	4.75	0	1.125	4.75
49	4	0	1.125	4
50	3.25	0	1.125	3.25
51	2.5	0	1.313	2.5
52	5.5	1.5	3.75	5.5
53	4	1.5	4.5	4
54	2.5	1.5	3.75	2.5
55	5.5	3	4.375	5.5
56	4	3	5.25	4
57	2.5	3	4.375	2.5

Conf. # 3C\_16\_2.5\_20/8, continued

Orif. #	Mom. arm	Sta. y	$\Delta$ .Area	Sta. x
36	1.5	0	1.313	1.5
37	0.75	0	1.125	0.75
38	0	0	1.125	0
39	-0.75	0	1.125	-0.75
40	-1.5	0	1.313	-1.5
41	1.5	1.5	3.75	1.5
42	0	1.5	4.5	0
43	-1.5	1.5	3.75	-1.5
44	1.5	3	4.375	1.5
45	0	3	5.25	0
46	-1.5	3	4.375	-1.5
58	-2.5	0	1.313	-2.5
59	-3.25	0	1.125	-3.25
60	-4	0	1.125	-4
61	-4.75	0	1.125	-4.75
62	-5.5	0	1.313	-5.5
63	-2.5	1.5	3.75	-2.5
64	-4	1.5	4.5	-4
65	-5.5	1.5	3.75	-5.5
66	-2.5	3	4.375	-2.5
67	-4	3	5.25	-4
68	-5.5	3	4.375	-5.5
84	-6.15	0	0.634	-6.15
85	-6.5	0	0.683	-6.5
86	-6.85	0	0.683	-6.85
87	-7.2	0	0.619	-7.2
88	-8.8	0	0.619	-8.8
89	-9.15	0	0.683	-9.15
90	-9.5	0	0.683	-9.5
91	-9.85	0	0.634	-9.85
93	-6.5	1.5	3.19	-6.5
94	-8	1.5	5.062	-8
95	-9.5	1.5	3.19	-9.5
96	-6.5	3	4.375	-6.5
97	-8	3	5.25	-8
98	-9.5	3	4.375	-9.5

Point	1	2	3	4	5	6	7	8	9	10
h/D <sub>0</sub> =	33.88	17.66	11.77	8.03	5.87	4.70	3.50	2.33	1.74	1.14
Total Thrust =	54.13	52.21	52.11	52.04	51.97	51.90	51.81	51.80	51.88	51.88
NPR Front =	2.15	2.06	2.06	2.06	2.06	2.05	2.05	2.05	2.05	2.05
NPR Aft =	2.01	2.00	2.00	2.00	2.00	2.00	2.00	2.00	2.00	2.00
X-1-loc	ACP	ACP	ACP	ACP	ACP	ACP	ACP	ACP	ACP	ACP
Y-1-loc	ACP	ACP	ACP	ACP	ACP	ACP	ACP	ACP	ACP	ACP
8.00	-0.001322	-0.001214	-0.001624	-0.002038	-0.003737	-0.003695	-0.003128	-0.005721	0.000703	0.014189
-0.48	-0.001033	-0.001291	-0.001217	-0.001546	-0.002555	-0.003104	-0.002571	-0.004861	0.000285	0.018376
8.00	-0.000825	-0.001037	-0.000992	-0.001303	-0.002193	-0.002793	-0.002553	-0.004603	0.000750	0.023646
-0.16	-0.000682	-0.000674	-0.000912	-0.001668	-0.002472	-0.002460	-0.002443	-0.003397	0.000963	0.043196
9.50	0.00	-0.000543	-0.000457	-0.000674	-0.001190	-0.001460	-0.001366	-0.002788	0.003462	0.012440
8.75	0.00	-0.000674	-0.000487	-0.000606	-0.001452	-0.001725	-0.001754	-0.002771	0.001190	0.023680
8.00	0.00	-0.000677	-0.000813	-0.000903	-0.001452	-0.002104	-0.002848	-0.002337	0.001557	0.045176
7.25	0.00	-0.000567	-0.001223	-0.000903	-0.001575	-0.002104	-0.003363	-0.003921	0.001670	0.057376
6.50	0.00	-0.000584	-0.000859	-0.000984	-0.001376	-0.002272	-0.003178	-0.004459	0.000976	0.031096
5.50	0.00	-0.002088	-0.000498	-0.000609	-0.001254	-0.002272	-0.003178	-0.004459	0.000195	0.005539
4.75	0.00	-0.000221	-0.000418	-0.000534	-0.000785	-0.000992	-0.001147	-0.001473	0.000461	0.005495
4.00	0.00	-0.000149	-0.000329	-0.000519	-0.000870	-0.001176	-0.001352	-0.001733	0.001101	0.010279
3.25	0.00	-0.000082	-0.000354	-0.000599	-0.000970	-0.001381	-0.001934	-0.002745	0.000441	0.008433
2.50	0.00	-0.000053	-0.000304	-0.000534	-0.000870	-0.001381	-0.001934	-0.002745	0.000441	0.008433
1.50	0.00	-0.000024	-0.000130	-0.000459	-0.000785	-0.001147	-0.001528	-0.002021	0.000761	0.012642
0.75	0.00	-0.000130	-0.000125	-0.000459	-0.000785	-0.001147	-0.001528	-0.002021	0.000761	0.012642
0.00	0.00	-0.000077	-0.000050	-0.000374	-0.000615	-0.000987	-0.001367	-0.001844	0.002246	0.000035
-0.75	0.00	-0.000135	-0.000055	-0.000394	-0.000685	-0.001031	-0.001413	-0.001883	0.002529	0.008727
-1.50	0.00	-0.000082	-0.000055	-0.000359	-0.000685	-0.001031	-0.001413	-0.001883	0.002529	0.008727
-2.50	0.00	-0.000202	-0.000060	-0.000334	-0.000660	-0.000977	-0.001352	-0.001844	0.002577	0.012565
-3.25	0.00	-0.000014	-0.000169	-0.000369	-0.000615	-0.000977	-0.001352	-0.001844	0.002577	0.012565
-4.00	0.00	-0.000341	-0.000130	-0.000329	-0.000575	-0.000870	-0.001176	-0.001528	0.002451	0.014244
-5.50	0.00	-0.000471	-0.000339	-0.000544	-0.000775	-0.001031	-0.001381	-0.001844	0.002451	0.014244
-6.15	0.00	-0.000529	-0.000663	-0.000544	-0.000775	-0.001031	-0.001381	-0.001844	0.002451	0.014244
-6.85	0.00	-0.000529	-0.000942	-0.000579	-0.000780	-0.001031	-0.001381	-0.001844	0.002451	0.014244
-7.20	0.00	-0.001220	-0.002306	-0.002096	-0.001429	-0.002096	-0.002376	-0.002677	0.003662	0.007954
-8.80	0.00	-0.001509	-0.002915	-0.002376	-0.001429	-0.002096	-0.002376	-0.002677	0.003662	0.007954
-9.15	0.00	-0.000718	-0.000905	-0.000400	-0.000400	-0.000555	-0.000625	-0.000670	0.000095	0.000276
-9.50	0.00	-0.000937	-0.001036	-0.001467	-0.002044	-0.002677	-0.003128	-0.003510	0.000951	0.009051
8.00	0.16	-0.000584	-0.001016	-0.001447	-0.001829	-0.002288	-0.002767	-0.003250	0.003209	0.008573
7.25	0.25	-0.000657	-0.001104	-0.001593	-0.002089	-0.002577	-0.003060	-0.003543	0.003508	0.011143
6.50	0.50	-0.000416	-0.000698	-0.000848	-0.001367	-0.001844	-0.002322	-0.002805	0.002720	0.044157
8.00	0.32	-0.000828	-0.001439	-0.001770	-0.002288	-0.002767	-0.003250	-0.003733	0.002720	0.035992
7.25	0.50	-0.000567	-0.000618	-0.000852	-0.001350	-0.001844	-0.002322	-0.002805	0.002720	0.037452
6.50	0.75	-0.001542	-0.001041	-0.001285	-0.001851	-0.002336	-0.002819	-0.003302	0.002147	0.037374
8.00	1.00	-0.000384	-0.000576	-0.000708	-0.001043	-0.001423	-0.001804	-0.002185	0.001951	0.017511
7.25	1.25	-0.000396	-0.001325	-0.001425	-0.002089	-0.002577	-0.003060	-0.003543	0.002720	0.058000
6.50	1.50	-0.000396	-0.001325	-0.001425	-0.002089	-0.002577	-0.003060	-0.003543	0.002720	0.058000
8.00	1.25	-0.000702	-0.000711	-0.000891	-0.001384	-0.001844	-0.002322	-0.002805	0.002720	0.018386
6.50	1.50	-0.000486	-0.000611	-0.000861	-0.001511	-0.002096	-0.002677	-0.003250	0.002720	0.027792
8.00	1.25	-0.001208	-0.000979	-0.001501	-0.002247	-0.002828	-0.003409	-0.003990	0.002720	0.029340
7.25	1.50	-0.000745	-0.000269	-0.000269	-0.001210	-0.002347	-0.002828	-0.003309	0.002720	0.021072
6.50	1.25	-0.000474	-0.000348	-0.000348	-0.001119	-0.002207	-0.002687	-0.003148	0.002720	0.021072
8.00	1.25	-0.000173	-0.000135	-0.000529	-0.001119	-0.001781	-0.002447	-0.003106	0.002720	0.008235
7.25	1.50	-0.000331	-0.000314	-0.000504	-0.000935	-0.001592	-0.002257	-0.002916	0.002720	0.013234
6.50	1.25	-0.000362	-0.000508	-0.000424	-0.000825	-0.001478	-0.002137	-0.002805	0.002720	0.011882
-1.50	1.25	-0.000125	-0.000120	-0.000394	-0.000755	-0.001188	-0.001628	-0.002100	0.002720	0.014008
-4.00	1.50	-0.000283	-0.000299	-0.000384	-0.000626	-0.001048	-0.001428	-0.001844	0.002720	0.010362
-5.50	1.50	-0.000283	-0.000299	-0.000384	-0.000626	-0.001048	-0.001428	-0.001844	0.002720	0.010362
-6.50	1.50	-0.000172	-0.001335	-0.001642	-0.002188	-0.002769	-0.003350	-0.003931	0.002720	0.007908
-8.00	1.50	-0.000673	-0.001211	-0.001478	-0.002074	-0.002769	-0.003450	-0.004141	0.002720	0.005795
-9.50	1.50	-0.000658	-0.000834	-0.001361	-0.002188	-0.002769	-0.003450	-0.004141	0.002720	0.022967
1.88	0.000718	-0.000957	-0.000945	-0.001341	-0.002543	-0.003128	-0.003710	-0.004292	0.002720	0.014609
8.00	0.000902	-0.001341	-0.002048	-0.002543	-0.003128	-0.003710	-0.004292	-0.004874	0.002720	0.014845
2.00	-0.001037	-0.000559	-0.001200	-0.001465	-0.002338	-0.002923	-0.003508	-0.004093	0.002720	0.019461
6.50	-0.000306	-0.000770	-0.000950	-0.001384	-0.002614	-0.003200	-0.003785	-0.004370	0.002720	0.022355

Point	1	2	3	4	5	6	7	8	9	10
h/De =	33.88	17.66	11.77	8.83	5.87	4.70	3.50	2.33	1.74	1.14
Total Thrust =	54.13	52.21	52.11	52.04	51.97	51.90	51.91	51.86	51.88	51.84
NPR Front =	2.15	2.06	2.06	2.06	2.06	2.05	2.05	2.05	2.05	2.05
NPR A/C =	2.01	2.00	2.00	2.00	2.00	2.00	2.00	2.00	2.00	1.99
X-loc	Y-loc	ΔCP	ΔCP	ΔCP	ΔCP	ΔCP	ΔCP	ΔCP	ΔCP	ΔCP
9.50	3.00	-0.000376	-0.000406	-0.000674	-0.001469	-0.001741	-0.001966	-0.002950	-0.006154	-0.008171
8.00	3.00	-0.000544	-0.000356	-0.000882	-0.001380	-0.001730	-0.002329	-0.004873	-0.006580	-0.009136
6.50	3.00	-0.000318	-0.000381	-0.000861	-0.001622	-0.002801	-0.003213	-0.004981	-0.009583	-0.009949
5.50	3.00	-0.000173	-0.000135	-0.000529	-0.001119	-0.000781	-0.000461	-0.001538	0.001493	0.003670
4.00	3.00	-0.000149	-0.000309	-0.000599	-0.001205	-0.000906	-0.000501	-0.001533	-0.002200	-0.002844
2.50	3.00	-0.000149	-0.000304	-0.000599	-0.001205	-0.000906	-0.000501	-0.001533	-0.002200	-0.002844
1.50	3.00	-0.000067	-0.000289	-0.000469	-0.000935	-0.000681	-0.000328	-0.000461	0.002049	0.006052
0.00	3.00	-0.000062	-0.000319	-0.000604	-0.000920	-0.001286	-0.001554	-0.002070	-0.005019	-0.006789
-1.50	3.00	-0.000062	-0.000319	-0.000604	-0.000920	-0.001286	-0.001554	-0.002070	-0.005019	-0.006789
-2.50	3.00	-0.000130	-0.000189	-0.000674	-0.000925	-0.001251	-0.001469	-0.001728	-0.005637	-0.007571
-4.00	3.00	-0.000346	-0.000344	-0.000624	-0.000925	-0.001465	-0.001930	-0.003442	-0.004881	-0.005786
-5.50	3.00	-0.000673	-0.001211	-0.001278	-0.002135	-0.001739	-0.001739	-0.001644	-0.002065	-0.003680
-6.50	3.00	-0.000389	-0.000349	-0.000764	-0.001095	-0.002187	-0.002300	-0.002430	-0.002976	-0.004201
-8.00	3.00	-0.000389	-0.000349	-0.000764	-0.001095	-0.002187	-0.002300	-0.002430	-0.002976	-0.004201
-9.50	3.00	-0.000389	-0.000349	-0.000764	-0.001095	-0.002187	-0.002300	-0.002430	-0.002976	-0.004201

Force and Moment Summary

Balance h/De =	33.88	17.66	11.77	8.83	5.87	4.70	3.50	2.33	1.74	1.14
Pressure AL/T =	-0.010	-0.015	-0.022	-0.035	-0.027	-0.043	-0.067	-0.101	-0.139	-0.212
Balance AH/TDe =	-0.013	-0.015	-0.026	-0.042	-0.039	-0.049	-0.076	-0.097	-0.131	-0.198
Pressure AM/TDe =	NOT AVAILABLE	NOT AVAILABLE	NOT AVAILABLE	NOT AVAILABLE	NOT AVAILABLE	NOT AVAILABLE	NOT AVAILABLE	NOT AVAILABLE	NOT AVAILABLE	NOT AVAILABLE
Balance Δh/TDe =	0.003	0.011	0.007	-0.004	0.019	0.032	0.025	0.055	0.103	0.201





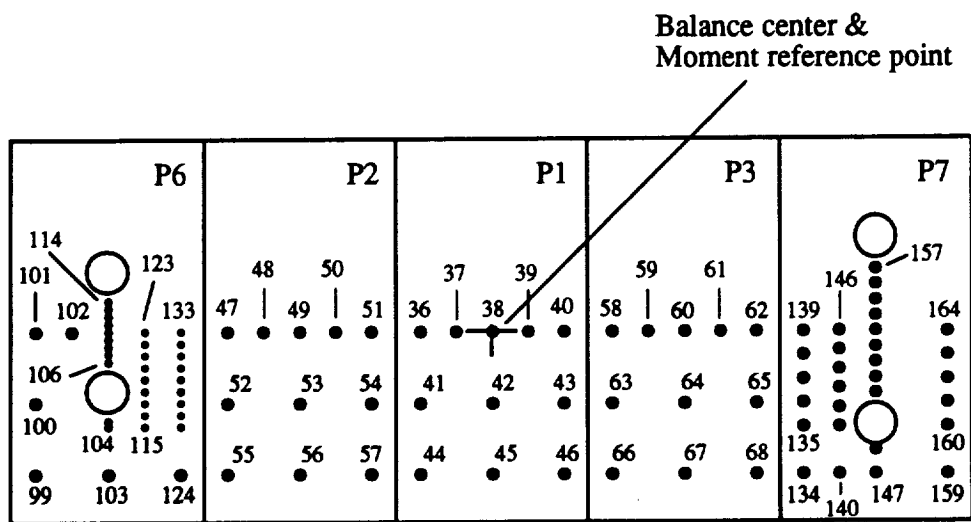

Figure 78. Configuration 4C\_16\_2.5/3.9\_20/8;  $D_e = 1.710$  in.,  $A_{jet} = 2.30$  in.<sup>2</sup>.



## Pressure Orifice Locations and Weighting Factors

Conf. # 4C-16-2.5/3.9-20/8

Distance from balance center to moment reference point,  $X_0 = 0$

Orif. #	Mom. arm	Sta. y	$\Delta$ .Area	Sta. x
99	9.5	3	4.688	9.5
100	9.165	1.5	4.38	9.5
101	9.5	0	1.313	9.5
102	8.75	0	1.125	8.75
103	8	3	5.625	8
104	8	2	0.278	8
105	8	1.88	0.38	8
106	8	0.64	0.38	8
107	8	0.48	0.24	8
108	8	0.32	0.24	8
109	8	0.16	0.24	8
110	8	0	0.12	8
111	8	-0.16	0	8
112	8	-0.32	0	8
113	8	-0.48	0	8
114	8	-0.64	0	8
115	7.25	2	0.375	7.25
116	7.25	1.75	0.375	7.25
117	7.25	1.5	0.355	7.25
118	7.25	1.25	0.325	7.25
119	7.25	1	0.355	7.25
120	7.25	0.75	0.375	7.25
121	7.25	0.5	0.375	7.25
122	7.25	0.25	0.375	7.25
123	7.25	0	0.188	7.25
124	6.5	3	4.688	6.5
125	6.5	2	0.438	6.5
126	6.5	1.75	0.438	6.5
127	6.5	1.5	0.438	6.5
128	6.5	1.25	0.438	6.5
129	6.5	1	0.438	6.5
130	6.5	0.75	0.438	6.5
131	6.5	0.5	0.438	6.5
132	6.5	0.25	0.438	6.5
133	6.5	0	0.219	6.5
47	5.5	0	1.313	5.5
48	4.75	0	1.125	4.75
49	4	0	1.125	4
50	3.25	0	1.125	3.25
51	2.5	0	1.313	2.5
52	5.5	1.5	3.75	5.5
53	4	1.5	4.5	4
54	2.5	1.5	3.75	2.5

Conf. # 4C\_16\_2.5/3.9\_20/8, continued

Orif. #	Mom. arm	Sta. y	Δ.Area	Sta. x
55	5.5	3	4.375	5.5
56	4	3	5.25	4
57	2.5	3	4.375	2.5
36	1.5	0	1.313	1.5
37	0.75	0	1.125	0.75
38	0	0	1.125	0
39	-0.75	0	1.125	-0.75
40	-1.5	0	1.313	-1.5
41	1.5	1.5	3.75	1.5
42	0	1.5	4.5	0
43	-1.5	1.5	3.75	-1.5
44	1.5	3	4.375	1.5
45	0	3	5.25	0
46	-1.5	3	4.375	-1.5
58	-2.5	0	1.313	-2.5
59	-3.25	0	1.125	-3.25
60	-4	0	1.125	-4
61	-4.75	0	1.125	-4.75
62	-5.5	0	1.313	-5.5
63	-2.5	1.5	3.75	-2.5
64	-4	1.5	4.5	-4
65	-5.5	1.5	3.75	-5.5
66	-2.5	3	4.375	-2.5
67	-4	3	5.25	-4
68	-5.5	3	4.375	-5.5
134	-6.5	3	3.063	-6.5
135	-6.5	2	0.875	-6.5
136	-6.5	1.5	0.875	-6.5
137	-6.5	1	0.875	-6.5
138	-6.5	0.5	0.875	-6.5
139	-6.5	0	0.438	-6.5
140	-7.25	3	2.625	-7.25
141	-7.25	2	0.534	-7.25
142	-7.25	1.6	0.575	-7.25
143	-7.25	1.2	0.6	-7.25
144	-7.25	0.8	0.6	-7.25
145	-7.25	0.4	0.6	-7.25
146	-7.25	0	0.3	-7.25
147	-8	3	2.006	-8
148	-8	2.5	0.54	-8
149	-8	1.3	0.54	-8
150	-8	0.975	0.488	-8
151	-8	0.65	0.488	-8
152	-8	0.325	0.488	-8
153	-8	0	0.4315	-8
154	-8	-0.325	0	-8
155	-8	-0.65	0	-8
156	-8	-0.975	0	-8
157	-8	-1.3	0	-8
159	-9.19	3	5.688	-9.5
160	-9.163	2	1.559	-9.5

Conf. # 4C\_16\_2.5/3.9\_20/8, continued

Orif. #	Mom. arm	Sta. y	$\Delta$ .Area	Sta. x
161	-9.163	1.5	1.6	-9.5
162	-9.163	1	1.625	-9.5
163	-9.163	0.5	1.625	-9.5
164	-9.5	0	0.6255	-9.5

Jet-Induced Pressure Increments  
 Configuration: 4C-16-2.5/3.9-20/8  
 Run 280  
 Page 1/2

Point	1	2	3	4	5	6	7	8	9	10
Total Thrust =	33.67	17.54	11.68	8.78	5.82	4.67	3.50	2.30	1.74	1.15
NFR Front =	51.66	51.33	51.27	51.29	51.24	51.19	51.23	51.17	51.17	51.09
NFR Aft =	2.03	2.03	2.03	2.03	2.02	2.02	2.02	2.02	2.02	2.02
X-loc	1.93	1.91	1.91	1.91	1.91	1.91	1.91	1.91	1.91	1.91
Y-loc	ACP	ACP	ACP	ACP	ACP	ACP	ACP	ACP	ACP	ACP
-8.00	-0.001875	-0.001567	-0.001558	-0.002272	-0.006057	-0.006028	-0.003129	-0.000558	0.000005	0.004312
-8.00	-0.001145	-0.001097	-0.000986	-0.001087	-0.002663	-0.002594	-0.002255	-0.000932	-0.000819	-0.009695
-8.00	-0.000689	-0.001720	-0.001083	-0.000730	-0.002653	-0.002605	-0.001748	-0.002068	-0.002268	-0.005209
-8.00	-0.001777	-0.001458	-0.001935	-0.002991	-0.002653	-0.004668	-0.005010	-0.008155	-0.008508	-0.014358
-8.00	-0.001287	-0.001356	-0.001668	-0.002083	-0.002692	-0.002909	-0.004092	-0.006736	-0.008705	-0.007206
-8.00	-0.001089	-0.000995	-0.001118	-0.002392	-0.002392	-0.003661	-0.006773	-0.014969	-0.028004	-0.028004
-8.00	-0.000932	-0.000663	-0.001328	-0.001908	-0.002548	-0.002017	-0.003624	-0.007668	-0.005633	-0.022900
-8.00	-0.000975	-0.001047	-0.001354	-0.001759	-0.002194	-0.002183	-0.003545	-0.007021	-0.003269	-0.029733
9.50	0.000621	-0.000803	-0.000926	-0.001843	-0.001136	-0.001243	-0.002575	-0.005353	-0.003445	-0.010169
8.75	0.000654	-0.001221	-0.001372	-0.001829	-0.001134	-0.001553	-0.003060	-0.006097	-0.004127	-0.022073
8.00	-0.001174	-0.000702	-0.001424	-0.001869	-0.002404	-0.002004	-0.003479	-0.006023	-0.01917	-0.042437
7.25	0.0001205	-0.001135	-0.001158	-0.001432	-0.002404	-0.002444	-0.003698	-0.006491	-0.03199	-0.044289
6.50	0.000776	-0.000807	-0.000983	-0.000917	-0.002426	-0.002771	-0.003741	-0.006904	-0.006713	-0.021821
5.50	0.000474	-0.000657	-0.000597	-0.001069	-0.001785	-0.002462	-0.003375	-0.003885	-0.001680	-0.000511
4.75	0.000398	-0.000457	-0.000530	-0.000936	-0.001734	-0.002457	-0.002897	-0.003221	-0.003204	-0.002410
4.00	-0.000286	-0.000334	-0.000710	-0.000981	-0.001734	-0.002457	-0.002897	-0.003221	-0.003204	-0.002410
3.25	0.000209	-0.000370	-0.000756	-0.000827	-0.001292	-0.001921	-0.001688	-0.001515	-0.002138	-0.002410
2.50	0.000332	-0.000252	-0.000638	-0.000858	-0.001301	-0.001998	-0.001544	-0.001778	-0.000557	-0.002111
1.75	0.000041	-0.000092	-0.000586	-0.000925	-0.000643	-0.000664	-0.001003	-0.003380	-0.000557	-0.002111
1.00	-0.000199	-0.000339	-0.000668	-0.000972	-0.000422	-0.000103	-0.001533	-0.003463	-0.004828	-0.009373
0.75	-0.000204	-0.000133	-0.000468	-0.000869	-0.000736	-0.001308	-0.003300	-0.006379	-0.005708	-0.011747
0.00	-0.000214	-0.000313	-0.000468	-0.000853	-0.000906	-0.002750	-0.003654	-0.007332	-0.009242	-0.013896
-1.50	0.000184	-0.000267	-0.000576	-0.000879	-0.001184	-0.003668	-0.004353	-0.006745	-0.010947	-0.014822
-2.50	0.000245	-0.000180	-0.000566	-0.000900	-0.002161	-0.002580	-0.003031	-0.002993	-0.008356	-0.010425
-3.25	0.000245	-0.000180	-0.000566	-0.000900	-0.002161	-0.002580	-0.003031	-0.002993	-0.008356	-0.010425
-4.00	0.000337	-0.000349	-0.000489	-0.000771	-0.000185	-0.000201	-0.001044	-0.000907	-0.004178	-0.005671
-4.75	0.000593	-0.000781	-0.000930	-0.001480	-0.002103	-0.002369	-0.003335	-0.003830	-0.009003	-0.039731
-5.50	0.000296	-0.000164	-0.000442	-0.000842	-0.002684	-0.003488	-0.003239	-0.001188	-0.004178	-0.011684
-6.50	0.001059	-0.000832	-0.000741	-0.000899	-0.003016	-0.003488	-0.003239	-0.001188	-0.004178	-0.011684
-7.25	0.000735	-0.000908	-0.000516	-0.000613	-0.002632	-0.002692	-0.001677	-0.005237	-0.015014	-0.031969
-8.00	0.000816	-0.001005	-0.000720	-0.000842	-0.002632	-0.002692	-0.001677	-0.005237	-0.015014	-0.031969
-8.50	0.000816	-0.001005	-0.000720	-0.000842	-0.002632	-0.002692	-0.001677	-0.005237	-0.015014	-0.031969
8.00	0.000988	-0.000777	-0.001167	-0.001579	-0.002369	-0.002835	-0.003348	-0.004666	-0.006057	-0.050717
7.25	0.000875	-0.000777	-0.001167	-0.001579	-0.002369	-0.002835	-0.003348	-0.004666	-0.006057	-0.050717
6.50	0.000693	-0.001170	-0.000930	-0.001480	-0.002103	-0.002369	-0.003335	-0.003830	-0.009003	-0.039731
5.50	0.000767	-0.001225	-0.001170	-0.001790	-0.002570	-0.002660	-0.003750	-0.004879	-0.012540	-0.046501
4.75	0.001130	-0.001225	-0.001170	-0.001790	-0.002570	-0.002660	-0.003750	-0.004879	-0.012540	-0.046501
4.00	0.001188	-0.001379	-0.001289	-0.002366	-0.002548	-0.002813	-0.003707	-0.004237	-0.018042	-0.043606
3.25	0.001036	-0.001135	-0.001332	-0.001746	-0.002517	-0.002953	-0.003444	-0.004237	-0.018042	-0.043606
2.50	0.000758	-0.000829	-0.001037	-0.001406	-0.002355	-0.002927	-0.003525	-0.004192	-0.007115	-0.016105
1.75	0.000613	-0.001178	-0.000991	-0.001559	-0.002390	-0.002962	-0.003621	-0.004183	-0.007115	-0.016105
1.00	0.000720	-0.001492	-0.001188	-0.001759	-0.002390	-0.002962	-0.003621	-0.004183	-0.007115	-0.016105
0.75	0.000793	-0.001300	-0.000858	-0.001353	-0.002194	-0.002370	-0.003179	-0.003735	-0.002088	-0.014496
7.25	0.000854	-0.000820	-0.000953	-0.001266	-0.002168	-0.002309	-0.003488	-0.004107	-0.011041	-0.003274
6.50	0.001023	-0.001210	-0.000914	-0.000848	-0.002591	-0.002231	-0.003538	-0.002666	-0.003274	-0.005727
5.50	0.001464	-0.001344	-0.000914	-0.000848	-0.002591	-0.002231	-0.003538	-0.002666	-0.003274	-0.005727
4.75	0.001464	-0.001344	-0.000914	-0.000848	-0.002591	-0.002231	-0.003538	-0.002666	-0.003274	-0.005727
4.00	0.000572	-0.000820	-0.001114	-0.001354	-0.002317	-0.002932	-0.003633	-0.004192	-0.007115	-0.016105
3.25	0.000816	-0.000791	-0.000552	-0.000659	-0.002317	-0.002932	-0.003633	-0.004192	-0.007115	-0.016105
2.50	0.000854	-0.001194	-0.000889	-0.000983	-0.002495	-0.002078	-0.003143	-0.003809	-0.007278	-0.022964
1.75	0.000854	-0.001194	-0.000889	-0.000983	-0.002495	-0.002078	-0.003143	-0.003809	-0.007278	-0.022964
1.00	0.001106	-0.001316	-0.001105	-0.001296	-0.002495	-0.002078	-0.003143	-0.003809	-0.007278	-0.022964
0.75	0.000719	-0.000820	-0.001105	-0.001296	-0.002495	-0.002078	-0.003143	-0.003809	-0.007278	-0.022964
6.50	0.001664	-0.000833	-0.001130	-0.001759	-0.002495	-0.002078	-0.003143	-0.003809	-0.007278	-0.022964
5.50	0.000793	-0.000833	-0.001130	-0.001759	-0.002495	-0.002078	-0.003143	-0.003809	-0.007278	-0.022964
4.75	0.000841	-0.000833	-0.001130	-0.001759	-0.002495	-0.002078	-0.003143	-0.003809	-0.007278	-0.022964
4.00	0.000449	-0.000822	-0.001123	-0.001205	-0.002495	-0.002078	-0.003143	-0.003809	-0.007278	-0.022964
3.25	0.000449	-0.000822	-0.001123	-0.001205	-0.002495	-0.002078	-0.003143	-0.003809	-0.007278	-0.022964
2.50	0.000337	-0.000216	-0.000627	-0.000937	-0.001214	-0.001582	-0.002138	-0.002654	-0.003274	-0.005727
1.75	0.000383	-0.000478	-0.000648	-0.000853	-0.000762	-0.001154	-0.001654	-0.002154	-0.002719	-0.006590
1.00	0.000066	-0.000565	-0.000581	-0.000905	-0.000041	-0.000151	-0.000253	-0.000421	-0.000719	-0.002077
-1.50	-0.000031	-0.000149	-0.000674	-0.000972	-0.001708	-0.003157	-0.004225	-0.005271	-0.007169	-0.009379
-2.50	-0.000031	-0.000072	-0.000602	-0.001033	-0.001503	-0.002060	-0.002525	-0.003581	-0.006255	-0.009379

Point	1	2	3	4	5	6	7	8	9	10
h/Da =	33.67	17.54	11.68	8.78	5.82	4.67	3.50	2.30	1.74	1.15
Total Thrust =	51.68	51.33	51.27	51.29	51.24	51.19	51.23	51.17	51.17	51.09
NPR Front =	2.03	2.03	2.03	2.03	2.03	2.02	2.02	2.02	2.02	2.02
NPR Aft =	1.93	1.91	1.91	1.91	1.91	1.91	1.91	1.91	1.91	1.91
X-loc	ACP	ACP	ACP	ACP	ACP	ACP	ACP	ACP	ACP	ACP
Y-loc	ACP	ACP	ACP	ACP	ACP	ACP	ACP	ACP	ACP	ACP
-4.00	-0.00071	-0.00231	-0.00056	-0.00858	-0.00370	0.00098	-0.00105	-0.01000	-0.00021	-0.00913
-5.50	-0.00015	-0.00236	-0.00024	-0.00679	-0.01832	-0.00271	-0.00242	-0.00580	-0.01073	-0.02035
-6.50	-0.00057	-0.00413	-0.00057	-0.00837	-0.01906	-0.00370	-0.00339	-0.00745	-0.01362	-0.02554
-9.50	-0.00689	-0.01102	-0.00124	-0.00888	-0.00495	-0.00120	-0.00123	-0.00561	-0.00950	-0.01764
-7.25	-0.00155	-0.00153	-0.00071	-0.00700	-0.02372	-0.00194	-0.00365	-0.00830	-0.01132	-0.02241
-7.25	-0.00992	-0.01291	-0.00159	-0.01668	-0.00263	-0.00403	-0.00443	-0.00425	-0.00710	-0.01987
-6.50	-0.00524	-0.00567	-0.00121	-0.01296	-0.01818	-0.00250	-0.00346	-0.00981	-0.00525	-0.02005
-8.00	-0.01304	-0.01876	-0.00365	-0.01065	-0.01818	-0.00474	-0.00593	-0.00981	-0.00525	-0.02005
-8.00	-0.00862	-0.01431	-0.00201	-0.01956	-0.03151	-0.00782	-0.00747	-0.00593	-0.00782	-0.01388
-7.25	-0.00641	-0.01194	-0.00141	-0.01389	-0.02080	-0.00340	-0.00474	-0.00474	-0.00700	-0.01574
-6.50	-0.00816	-0.01405	-0.00637	-0.00948	-0.01484	-0.00259	-0.00340	-0.00480	-0.00966	-0.01789
-7.25	-0.00816	-0.01194	-0.00628	-0.00948	-0.02004	-0.00340	-0.00340	-0.00480	-0.00966	-0.01789
-9.50	-0.00933	-0.01225	-0.00731	-0.00894	-0.02428	-0.00340	-0.00340	-0.00480	-0.00966	-0.01789
-8.00	-0.00933	-0.01225	-0.00731	-0.00894	-0.02428	-0.00340	-0.00340	-0.00480	-0.00966	-0.01789
-9.50	-0.00520	-0.00572	-0.00124	-0.00985	-0.06521	-0.00113	-0.00113	-0.00597	-0.00874	-0.01947
-8.00	-0.00411	-0.00572	-0.00087	-0.01633	-0.01306	-0.00149	-0.00253	-0.00430	-0.00724	-0.01034
-5.50	-0.00438	-0.00576	-0.00098	-0.01327	-0.01496	-0.00189	-0.00321	-0.00581	-0.00924	-0.01296
-5.50	-0.00337	-0.00211	-0.00027	-0.00957	-0.01118	-0.00148	-0.00354	-0.00581	-0.00924	-0.01296
-4.00	-0.00403	-0.00555	-0.00056	-0.01167	-0.01147	-0.00201	-0.00318	-0.00584	-0.00924	-0.01296
-3.00	-0.00403	-0.00555	-0.00056	-0.01167	-0.01147	-0.00201	-0.00318	-0.00584	-0.00924	-0.01296
-1.50	-0.00377	-0.00303	-0.00042	-0.00915	-0.00401	-0.00051	-0.00072	-0.00382	-0.00749	-0.00540
-1.50	-0.00265	-0.00241	-0.00042	-0.00818	-0.00479	-0.00060	-0.00241	-0.00154	-0.00402	-0.00091
-2.50	-0.00173	-0.00391	-0.00049	-0.00792	-0.01580	0.00320	0.00189	0.00388	0.00217	0.00207
-4.50	-0.00030	-0.00546	-0.00043	-0.00958	-0.00453	0.00370	0.00155	0.00318	0.00217	0.00207
-5.50	-0.00030	-0.00546	-0.00043	-0.00958	-0.00453	0.00370	0.00155	0.00318	0.00217	0.00207
-7.25	-0.00046	-0.00970	-0.00064	-0.00495	-0.01441	-0.00247	-0.00329	-0.00560	-0.00780	-0.00957
-8.00	-0.00093	-0.00704	-0.00071	-0.00814	-0.02710	-0.00304	-0.00341	-0.00607	-0.00688	-0.00901
-9.50	-0.00623	-0.00680	-0.00104	-0.00582	-0.00112	-0.00125	-0.00135	-0.00436	-0.00594	-0.00764

Force and Moment Summary  
 Balance Δ/T = 33.67  
 Pressure Δ/T = -0.018  
 Balance ΔH/T = 0.015  
 Pressure ΔH/T = 0.055  
 Balance ΔH/TID = -0.009  
 Pressure ΔH/TID = 0.003



Configuration: 4C-16-2.5/3.9-20/8 Jet-Induced Pressure Increments Run 282

Point	1-75	2-35	3-49	4-69	5-85	6-78	7-72	8-56
Total Thrust =	219.90	219.90	219.90	220.14	219.90	219.90	219.90	219.90
NPR Front =	5.96	5.96	5.96	5.96	5.95	5.96	5.96	5.96
NPR Aft =	5.67	5.67	5.67	5.67	5.66	5.66	5.66	5.66
X-loc	ACP	ACP	ACP	ACP	ACP	ACP	ACP	ACP
h/D=	1.50	1.50	1.50	1.50	1.50	1.50	1.50	1.50
h/D=	1.75	2.35	3.49	4.69	5.85	8.78	11.72	17.56
Y-loc	ACP	ACP	ACP	ACP	ACP	ACP	ACP	ACP
h/D=	1.50	1.50	1.50	1.50	1.50	1.50	1.50	1.50
h/D=	1.75	2.35	3.49	4.69	5.85	8.78	11.72	17.56
Y-loc	ACP	ACP	ACP	ACP	ACP	ACP	ACP	ACP

Force and Moment Summary

Balance	AL/T =	h/D=	3-49	4-69	5-85	6-78	7-72	8-56
Pressure	0.055	1.75	0.036	0.023	0.019	0.027	0.020	0.014
Moment	0.017	2.35	0.005	0.005	0.018	0.030	0.023	0.015
Pressure	0.017	3.49	0.001	0.020	0.014	0.014	0.017	0.021
Moment	-0.039	4.69	-0.044	-0.017	-0.029	-0.016	-0.006	0.002

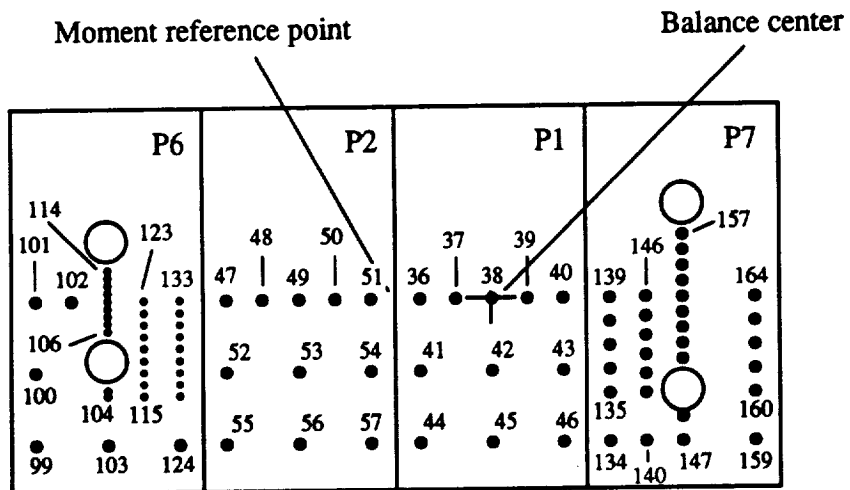

Figure 79. Configuration 4C\_12\_2.5/3.9\_16/8;  $D_e = 1.710$  in.,  $A_{jet} = 2.30$  in.<sup>2</sup>.



## Pressure Orifice Locations and Weighting Factors

Conf. # 4C-12-2.5/3.9-16/8

Distance from balance center to moment reference point,  $X_0 = 2$

Orif. #	Mom. arm	Sta. y	$\Delta$ .Area	Sta. x
99	7.5	3	4.688	7.5
100	7.165	1.5	4.38	7.5
101	7.5	0	1.313	7.5
102	6.75	0	1.125	6.75
103	6	3	5.625	6
104	6	2	0.278	6
105	6	1.88	0.38	6
106	6	0.64	0.38	6
107	6	0.48	0.24	6
108	6	0.32	0.24	6
109	6	0.16	0.24	6
110	6	0	0.12	6
111	6	-0.16	0	6
112	6	-0.32	0	6
113	6	-0.48	0	6
114	6	-0.64	0	6
115	5.25	2	0.375	5.25
116	5.25	1.75	0.375	5.25
117	5.25	1.5	0.355	5.25
118	5.25	1.25	0.325	5.25
119	5.25	1	0.355	5.25
120	5.25	0.75	0.375	5.25
121	5.25	0.5	0.375	5.25
122	5.25	0.25	0.375	5.25
123	5.25	0	0.188	5.25
124	4.5	3	4.688	4.5
125	4.5	2	0.438	4.5
126	4.5	1.75	0.438	4.5
127	4.5	1.5	0.438	4.5
128	4.5	1.25	0.438	4.5
129	4.5	1	0.438	4.5
130	4.5	0.75	0.438	4.5
131	4.5	0.5	0.438	4.5
132	4.5	0.25	0.438	4.5
133	4.5	0	0.219	4.5
47	3.5	0	1.313	3.5
48	2.75	0	1.125	2.75
49	2	0	1.125	2
50	1.25	0	1.125	1.25
51	0.5	0	1.313	0.5
52	3.5	1.5	3.75	3.5
53	2	1.5	4.5	2
54	0.5	1.5	3.75	0.5
55	3.5	3	4.375	3.5
56	2	3	5.25	2
57	0.5	3	4.375	0.5

Conf. # 4C\_12\_2.5/3.9\_16/8, continued

Orif. #	Mom. arm	Sta. y	Δ.Area	Sta. x
36	-0.5	0	1.313	-0.5
37	-1.25	0	1.125	-1.25
38	-2	0	1.125	-2
39	-2.75	0	1.125	-2.75
40	-3.5	0	1.313	-3.5
41	-0.5	1.5	3.75	-0.5
42	-2	1.5	4.5	-2
43	-3.5	1.5	3.75	-3.5
44	-0.5	3	4.375	-0.5
45	-2	3	5.25	-2
46	-3.5	3	4.375	-3.5
134	-4.44	3	3.063	-4.5
135	-4.44	2	0.875	-4.5
136	-4.44	1.5	0.875	-4.5
137	-4.44	1	0.875	-4.5
138	-4.44	0.5	0.875	-4.5
139	-4.44	0	0.438	-4.5
140	-5.25	3	2.625	-5.25
141	-5.25	2	0.534	-5.25
142	-5.25	1.6	0.575	-5.25
143	-5.25	1.2	0.6	-5.25
144	-5.25	0.8	0.6	-5.25
145	-5.25	0.4	0.6	-5.25
146	-5.25	0	0.3	-5.25
147	-6	3	2.006	-6
148	-6	2.5	0.54	-6
149	-6	1.3	0.54	-6
150	-6	0.975	0.488	-6
151	-6	0.65	0.488	-6
152	-6	0.325	0.488	-6
153	-6	0	0.244	-6
154	-6	-0.325	0	-6
155	-6	-0.65	0	-6
156	-6	-0.975	0	-6
157	-6	-1.3	0	-6
159	-7.19	3	5.688	-7.5
160	-7.163	2	1.559	-7.5
161	-7.163	1.5	1.6	-7.5
162	-7.163	1	1.625	-7.5
163	-7.163	0.5	1.625	-7.5
164	-7.5	0	0.438	-7.5



Point	1	2	3	4	5	6	7	8	9	10
Total Thrust =	33.67	17.55	11.72	8.78	5.87	4.67	3.50	2.34	1.74	1.14
NPA Front =	52.93	52.46	52.33	52.34	52.33	52.33	52.36	52.28	52.27	52.27
NPA Alt =	2.07	2.06	2.06	2.05	2.05	2.05	2.05	2.05	2.05	2.05
X-loc	1.96	1.95	1.95	1.95	1.95	1.95	1.95	1.95	1.95	1.95
Y-loc	ACP	ACP	ACP	ACP	ACP	ACP	ACP	ACP	ACP	ACP
6.00	-0.000876	-0.001194	-0.002070	-0.001838	-0.004021	-0.004755	-0.008867	-0.005341	-0.009263	-0.013614
5.25	-0.000728	-0.000849	-0.001264	-0.001470	-0.002832	-0.003484	-0.005128	-0.006588	-0.010221	-0.017815
4.50	-0.000580	-0.000618	-0.000948	-0.001659	-0.002362	-0.003060	-0.004692	-0.007021	-0.010519	-0.020091
-4.50	-0.001099	-0.001147	-0.001633	-0.001514	-0.000501	-0.000501	-0.003637	-0.006367	-0.013196	-0.020989
-5.25	-0.000396	-0.000883	-0.001303	-0.001479	-0.001276	-0.002007	-0.004498	-0.010597	-0.017862	-0.028881
-7.50	-0.000851	-0.000983	-0.001144	-0.001479	-0.000991	-0.001532	-0.002066	-0.003406	-0.007721	-0.012130
7.50	-0.000470	-0.001362	-0.001373	-0.001445	-0.009261	-0.014641	-0.017867	-0.008236	-0.008368	-0.010083
6.00	-0.000444	-0.000806	-0.000850	-0.001394	-0.001651	-0.001395	-0.002229	-0.003178	-0.007764	-0.009378
3.00	-0.000580	-0.000678	-0.000991	-0.001329	-0.002403	-0.002722	-0.003691	-0.004583	-0.008299	-0.010310
4.50	-0.000199	-0.000767	-0.000811	-0.001376	-0.002028	-0.002653	-0.003619	-0.005633	-0.010388	-0.011514
3.00	-0.000623	-0.000643	-0.000849	-0.001208	-0.000952	-0.001240	-0.004119	-0.004952	-0.003268	-0.002618
2.00	-0.000473	-0.000547	-0.000457	-0.001021	-0.000927	-0.000610	-0.000347	-0.001215	-0.003470	-0.006038
0.50	-0.000119	-0.000417	-0.000895	-0.000891	-0.001566	-0.003351	-0.006018	-0.005103	-0.002663	-0.003375
3.00	-0.000543	-0.000828	-0.001031	-0.001348	-0.001305	-0.003305	-0.002941	-0.000646	-0.001750	-0.003475
-4.50	-0.000460	-0.000833	-0.001528	-0.001194	-0.000596	-0.001091	-0.001022	-0.003904	-0.005790	-0.010391
-3.25	-0.000228	-0.000773	-0.001373	-0.001410	-0.001366	-0.002092	-0.004557	-0.004279	-0.006414	-0.010838
-6.00	-0.000529	-0.001207	-0.001203	-0.001385	-0.001746	-0.005255	-0.007249	-0.004634	-0.006093	-0.007677
-7.50	-0.000851	-0.000878	-0.001214	-0.001390	-0.001111	-0.001992	-0.002086	-0.002740	-0.004444	-0.006630

Force and Moment Summary

Balance	h/Ds =	33.67	17.55	11.72	8.78	5.87	4.67	3.50	2.34	1.74	1.14
Pressure	AL/T =	-0.011	-0.016	-0.018	-0.026	-0.009	-0.007	-0.016	-0.040	-0.079	-0.144
Balance	AM/Ts =	0.015	0.014	0.016	0.011	-0.016	-0.013	0.003	-0.000	-0.006	-0.003
Pressure	AM/TDs =	-0.002	0.001	0.004	-0.006	-0.034	-0.023	-0.017	-0.008	0.009	0.048

Jet-Induced Pressure Increments Run 284

Point	1	2	3	4	5	6	7	8
h/D =	17.54	11.70	8.79	5.82	4.68	3.47	2.31	1.76
Total Thrust =	135.01	135.88	135.88	135.82	135.86	135.89	135.96	135.91
NPR P/De =	4.01	4.01	4.01	4.01	4.02	4.02	4.02	4.02
NPR A/D =	3.81	3.80	3.80	3.80	3.80	3.80	3.80	3.79
X-loc	ACP	ACP	ACP	ACP	ACP	ACP	ACP	ACP
Y-loc	ACP	ACP	ACP	ACP	ACP	ACP	ACP	ACP
Point	1	2	3	4	5	6	7	8
h/D =	17.54	11.70	8.79	5.82	4.68	3.47	2.31	1.76
Total Thrust =	135.01	135.88	135.88	135.82	135.86	135.89	135.96	135.91
NPR P/De =	4.01	4.01	4.01	4.01	4.02	4.02	4.02	4.02
NPR A/D =	3.81	3.80	3.80	3.80	3.80	3.80	3.80	3.79
X-loc	ACP	ACP	ACP	ACP	ACP	ACP	ACP	ACP
Y-loc	ACP	ACP	ACP	ACP	ACP	ACP	ACP	ACP
Point	1	2	3	4	5	6	7	8
h/D =	17.54	11.70	8.79	5.82	4.68	3.47	2.31	1.76
Total Thrust =	135.01	135.88	135.88	135.82	135.86	135.89	135.96	135.91
NPR P/De =	4.01	4.01	4.01	4.01	4.02	4.02	4.02	4.02
NPR A/D =	3.81	3.80	3.80	3.80	3.80	3.80	3.80	3.79
X-loc	ACP	ACP	ACP	ACP	ACP	ACP	ACP	ACP
Y-loc	ACP	ACP	ACP	ACP	ACP	ACP	ACP	ACP

Force and Moment Summary

Balance	h/D = 17.54	11.70	8.79	5.82	4.68	3.47	2.31	1.76
Pressure	AL/T = -0.013	-0.016	-0.023	-0.013	-0.009	-0.011	-0.042	-0.067
Balance	AL/T = -0.018	-0.018	-0.030	-0.021	-0.013	-0.013	-0.041	-0.055
Pressure	AM/TDe = 0.000	-0.003	-0.011	-0.017	-0.025	-0.019	-0.007	-0.007
Balance	AM/TDe = -0.001	0.004	-0.018	-0.023	-0.025	-0.023	-0.004	-0.008

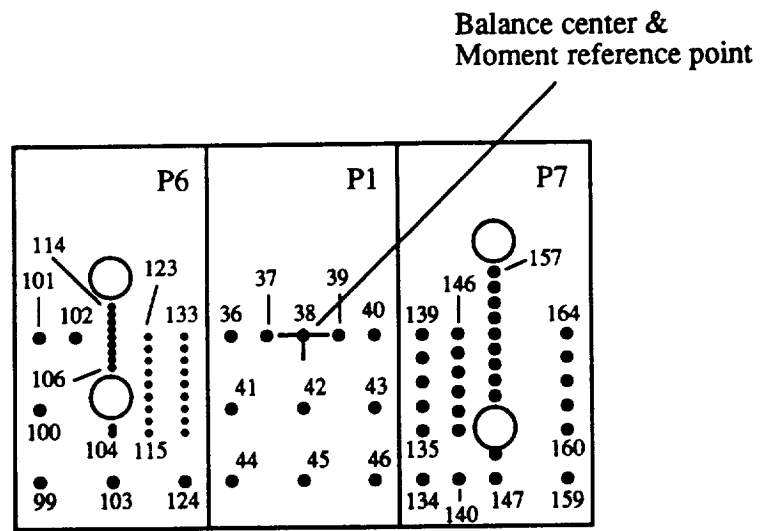

Figure 80. Configuration 4C\_872.5/3.9\_12/8;  $D_e = 1.710$  in.,  $A_{jet} = 2.30$  in.<sup>2</sup>.

## Pressure Orifice Locations and Weighting Factors

Conf. # 4C-8-2.5/3.9-12/8

Distance from balance center to moment reference point,  $X_0 = 0$

Orif. #	Mom. arm	Sta. y	$\Delta$ .Area	Sta. x
99	5.5	3	4.688	5.5
100	5.165	1.5	4.38	5.5
101	5.5	0	1.313	5.5
102	4.75	0	1.125	4.75
103	4	3	5.625	4
104	4	2	0.278	4
105	4	1.88	0.38	4
106	4	0.64	0.38	4
107	4	0.48	0.24	4
108	4	0.32	0.24	4
109	4	0.16	0.24	4
110	4	0	0.12	4
111	4	-0.16	0	4
112	4	-0.32	0	4
113	4	-0.48	0	4
114	4	-0.64	0	4
115	3.25	2	0.375	3.25
116	3.25	1.75	0.375	3.25
117	3.25	1.5	0.355	3.25
118	3.25	1.25	0.325	3.25
119	3.25	1	0.355	3.25
120	3.25	0.75	0.375	3.25
121	3.25	0.5	0.375	3.25
122	3.25	0.25	0.375	3.25
123	3.25	0	0.188	3.25
124	2.5	3	4.688	2.5
125	2.5	2	0.438	2.5
126	2.5	1.75	0.438	2.5
127	2.5	1.5	0.438	2.5
128	2.5	1.25	0.438	2.5
129	2.5	1	0.438	2.5
130	2.5	0.75	0.438	2.5
131	2.5	0.5	0.438	2.5
132	2.5	0.25	0.438	2.5
133	2.5	0	0.219	2.5
36	1.5	0	1.313	1.5
37	0.75	0	1.125	0.75
38	0	0	1.125	0
39	-0.75	0	1.125	-0.75
40	-1.5	0	1.313	-1.5
41	1.5	1.5	3.75	1.5
42	0	1.5	4.5	0
43	-1.5	1.5	3.75	-1.5
44	1.5	3	4.375	1.5
45	0	3	5.25	0
46	-1.5	3	4.375	-1.5

Conf. # 4C\_8\_2.5/3.9\_12/8, continued

Orif. #	Mom. arm	Sta. y	Δ.Area	Sta. x
134	-2.5	3	3.063	-2.5
135	-2.5	2	0.875	-2.5
136	-2.5	1.5	0.875	-2.5
137	-2.5	1	0.875	-2.5
138	-2.5	0.5	0.875	-2.5
139	-2.5	0	0.438	-2.5
140	-3.25	3	2.625	-3.25
141	-3.25	2	0.534	-3.25
142	-3.25	1.6	0.575	-3.25
143	-3.25	1.2	0.6	-3.25
144	-3.25	0.8	0.6	-3.25
145	-3.25	0.4	0.6	-3.25
146	-3.25	0	0.3	-3.25
147	-4	3	2.006	-4
148	-4	2.5	0.54	-4
149	-4	1.3	0.54	-4
150	-4	0.975	0.488	-4
151	-4	0.65	0.488	-4
152	-4	0.325	0.488	-4
153	-4	0	0.4315	-4
154	-4	-0.325	0	-4
155	-4	-0.65	0	-4
156	-4	-0.975	0	-4
157	-4	-1.3	0	-4
159	-5.19	3	5.688	-5.5
160	-5.163	2	1.559	-5.5
161	-5.163	1.5	1.6	-5.5
162	-5.163	1	1.625	-5.5
163	-5.163	0.5	1.625	-5.5
164	-5.5	0	0.6255	-5.5



Point	1	2	3	4	5	6	7	8	9	10
Total Thrust =	33.67	17.55	11.68	8.77	5.83	4.67	3.40	2.33	1.73	1.16
NPR Front =	51.51	52.31	52.23	52.14	52.09	52.10	52.10	52.08	52.05	52.01
NPR Aft =	2.04	2.05	2.05	2.04	2.04	2.04	2.04	2.04	2.04	2.01
X-loc	1.92	1.94	1.94	1.94	1.94	1.94	1.94	1.94	1.94	1.94
Y-loc	ΔCP	ΔCP	ΔCP	ΔCP	ΔCP	ΔCP	ΔCP	ΔCP	ΔCP	ΔCP
-1.30	-0.001953	-0.003134	-0.002507	-0.002336	-0.003500	-0.008793	-0.012154	-0.012482	-0.007814	-0.012189
-4.00	-0.000437	-0.001247	-0.000752	-0.001527	-0.000593	-0.003253	-0.007028	-0.008756	-0.006516	-0.016516
-4.00	-0.000330	-0.001542	-0.001244	-0.001397	-0.000417	-0.002829	-0.004721	-0.006300	-0.004531	-0.003559
-4.00	-0.001394	-0.001965	-0.002033	-0.002254	-0.004510	-0.010016	-0.014377	-0.010898	-0.004204	-0.008471
-4.00	-0.001570	-0.000745	-0.000882	-0.001761	-0.000338	-0.006482	-0.010973	-0.009266	-0.003515	-0.012126
-4.00	-0.000961	-0.001437	-0.000963	-0.001421	-0.000271	-0.006191	-0.006096	-0.006096	-0.003515	-0.016506
-4.00	-0.001365	-0.001036	-0.000225	-0.001739	-0.003242	-0.006242	-0.008379	-0.007435	-0.000903	-0.01942
-4.00	-0.001443	-0.000625	-0.001899	-0.001533	-0.003160	-0.005214	-0.008658	-0.008653	-0.001652	-0.025471
5.50	-0.001027	-0.001413	-0.001278	-0.001679	-0.001690	-0.002184	-0.003475	-0.003475	-0.001289	-0.011190
4.75	-0.000865	-0.000484	-0.001651	-0.001817	-0.002877	-0.005243	-0.008184	-0.008184	-0.000805	-0.039964
4.00	-0.000865	-0.000938	-0.000369	-0.001705	-0.002928	-0.004715	-0.008168	-0.008777	-0.000805	-0.039964
2.50	-0.000474	-0.000287	-0.000497	-0.001241	-0.002627	-0.003228	-0.005775	-0.005775	-0.001067	-0.031432
1.50	-0.000423	-0.000413	-0.000222	-0.000854	-0.001417	-0.002693	-0.002403	-0.002403	-0.001067	-0.031432
0.75	-0.000369	-0.000101	-0.000242	-0.000905	-0.001012	-0.00627	-0.002505	-0.002505	-0.001067	-0.031432
0.00	-0.000566	-0.000348	-0.000255	-0.000849	-0.001197	-0.005886	-0.004337	-0.004337	-0.001067	-0.031432
-0.75	-0.000031	-0.000242	-0.000061	-0.000794	-0.001199	-0.005718	-0.004769	-0.004769	-0.001067	-0.031432
-1.50	-0.000194	-0.000232	-0.000045	-0.000794	-0.001199	-0.005718	-0.004769	-0.004769	-0.001067	-0.031432
-2.50	-0.000270	-0.000116	-0.000185	-0.000583	-0.001689	-0.004620	-0.003278	-0.003278	-0.001067	-0.031432
-3.25	-0.000468	-0.000716	-0.000150	-0.000758	-0.003232	-0.002624	-0.003278	-0.003278	-0.001067	-0.031432
-4.00	-0.000936	-0.002259	-0.000291	-0.000814	-0.000895	-0.001186	-0.002765	-0.002765	-0.001067	-0.031432
-5.50	-0.001205	-0.001672	-0.001274	-0.001427	-0.002131	-0.001906	-0.004047	-0.004047	-0.001067	-0.031432
4.00	-0.000778	-0.001023	-0.001158	-0.002203	-0.003049	-0.005953	-0.009122	-0.009122	-0.001067	-0.031432
3.25	-0.000522	-0.000424	-0.001462	-0.001469	-0.003315	-0.005201	-0.007841	-0.007841	-0.001067	-0.031432
2.50	-0.000522	-0.000424	-0.001462	-0.001469	-0.003315	-0.005201	-0.007841	-0.007841	-0.001067	-0.031432
4.00	-0.001069	-0.001379	-0.000982	-0.001869	-0.002657	-0.003684	-0.006147	-0.006147	-0.001067	-0.031432
-4.00	-0.000920	-0.001898	-0.000943	-0.001191	-0.00453	-0.007140	-0.01180	-0.01180	-0.001067	-0.031432
-3.25	-0.000447	-0.001362	-0.000752	-0.000784	-0.00442	-0.00785	-0.003862	-0.003862	-0.001067	-0.031432
4.00	-0.001074	-0.001507	-0.001642	-0.002362	-0.004278	-0.00785	-0.003862	-0.003862	-0.001067	-0.031432
3.25	-0.000313	-0.000816	-0.000566	-0.001250	-0.002132	-0.003181	-0.004153	-0.004153	-0.001067	-0.031432
2.50	-0.000270	-0.000816	-0.000566	-0.001250	-0.002132	-0.003181	-0.004153	-0.004153	-0.001067	-0.031432
-2.50	-0.001012	-0.001672	-0.001459	-0.001622	-0.000070	-0.00352	-0.003329	-0.003329	-0.001067	-0.031432
-5.50	-0.002057	-0.002064	-0.002692	-0.002835	-0.00589	-0.010184	-0.015690	-0.015690	-0.001067	-0.031432
-4.00	-0.000727	-0.001382	-0.001218	-0.001447	-0.00417	-0.003816	-0.006466	-0.006466	-0.001067	-0.031432
3.25	-0.000900	-0.001019	-0.001347	-0.001954	-0.003684	-0.002979	-0.005679	-0.005679	-0.001067	-0.031432
2.50	-0.000387	-0.001032	-0.000489	-0.001491	-0.002330	-0.002979	-0.005679	-0.005679	-0.001067	-0.031432
-3.25	-0.000509	-0.000726	-0.000692	-0.000753	-0.000578	-0.003499	-0.007581	-0.007581	-0.001067	-0.031432
-4.00	-0.001018	-0.001165	-0.001191	-0.001788	-0.001675	-0.006038	-0.011008	-0.011008	-0.001067	-0.031432
3.25	-0.000596	-0.000372	-0.000622	-0.000739	-0.002485	-0.003125	-0.004350	-0.004350	-0.001067	-0.031432
2.50	-0.000270	-0.000816	-0.000507	-0.000728	-0.001815	-0.002575	-0.004240	-0.004240	-0.001067	-0.031432
-2.50	-0.000402	-0.001582	-0.000928	-0.000728	-0.000563	-0.001337	-0.003293	-0.003293	-0.001067	-0.031432
3.25	-0.000713	-0.001139	-0.001175	-0.002006	-0.002859	-0.003957	-0.004947	-0.004947	-0.001067	-0.031432
2.50	-0.000669	-0.000881	-0.000939	-0.001907	-0.002541	-0.002687	-0.003400	-0.003400	-0.001067	-0.031432
-4.00	-0.001580	-0.001562	-0.001128	-0.001788	-0.001675	-0.006038	-0.011008	-0.011008	-0.001067	-0.031432
5.50	-0.000609	-0.001272	-0.001128	-0.001460	-0.001599	-0.002360	-0.002661	-0.002661	-0.001067	-0.031432
3.25	-0.000609	-0.001272	-0.001128	-0.001460	-0.001599	-0.002360	-0.002661	-0.002661	-0.001067	-0.031432
2.50	-0.000609	-0.001272	-0.001128	-0.001460	-0.001599	-0.002360	-0.002661	-0.002661	-0.001067	-0.031432
1.50	-0.000454	-0.000504	-0.000445	-0.001102	-0.001210	-0.002829	-0.002632	-0.002632	-0.001067	-0.031432
0.00	-0.000356	-0.000459	-0.000431	-0.000804	-0.001103	-0.008345	-0.014496	-0.014496	-0.001067	-0.031432
-1.50	-0.000356	-0.000459	-0.000431	-0.000804	-0.001103	-0.008345	-0.014496	-0.014496	-0.001067	-0.031432
-2.50	-0.000722	-0.001692	-0.001168	-0.001687	-0.000648	-0.003253	-0.005902	-0.005902	-0.001067	-0.031432
-3.25	-0.000522	-0.001893	-0.000998	-0.001687	-0.000648	-0.003253	-0.005902	-0.005902	-0.001067	-0.031432
2.50	-0.000522	-0.000877	-0.001171	-0.002487	-0.002623	-0.003796	-0.005236	-0.005236	-0.001067	-0.031432
1.75	-0.000739	-0.001156	-0.001158	-0.001636	-0.002721	-0.003969	-0.005236	-0.005236	-0.001067	-0.031432
4.00	-0.000659	-0.000813	-0.001141	-0.001855	-0.003955	-0.005236	-0.005236	-0.005236	-0.001067	-0.031432
3.25	-0.000659	-0.000813	-0.001141	-0.001855	-0.003955	-0.005236	-0.005236	-0.005236	-0.001067	-0.031432
2.50	-0.000659	-0.000813	-0.001141	-0.001855	-0.003955	-0.005236	-0.005236	-0.005236	-0.001067	-0.031432
-2.50	-0.000659	-0.000813	-0.001141	-0.001855	-0.003955	-0.005236	-0.005236	-0.005236	-0.001067	-0.031432
-3.25	-0.000659	-0.000813	-0.001141	-0.001855	-0.003955	-0.005236	-0.005236	-0.005236	-0.001067	-0.031432
-4.00	-0.000447	-0.001662	-0.001108	-0.002059	-0.000230	-0.000704	-0.003212	-0.003212	-0.001067	-0.031432
5.50	-0.000661	-0.000877	-0.000948	-0.001482	-0.001745	-0.002184	-0.002906	-0.002906	-0.001067	-0.031432

Point	1	2	3	4	5	6	7	8	9	10
h/De =	33.67	17.55	11.68	8.77	5.83	4.67	3.49	2.33	1.73	1.16
Total Thrust =	51.51	52.31	52.23	52.14	52.09	52.10	52.10	52.08	52.05	52.01
NFR Front =	2.04	2.05	2.05	2.04	2.04	2.04	2.04	2.04	2.04	2.04
NFR Aft =	1.92	1.94	1.94	1.94	1.94	1.94	1.94	1.94	1.94	1.94
X-loc	ACP	ACP	ACP	ACP	ACP	ACP	ACP	ACP	ACP	ACP
Y-loc	ACP	ACP	ACP	ACP	ACP	ACP	ACP	ACP	ACP	ACP
4.00	-0.000665	-0.000732	-0.000879	-0.001460	-0.002197	-0.003748	-0.005652	-0.007203	-0.007185	-0.009239
2.50	-0.000739	-0.000822	-0.001012	-0.001366	-0.001474	-0.002631	-0.005679	-0.007809	-0.009738	-0.011508
1.50	-0.000594	-0.000897	-0.000495	-0.001395	-0.001018	-0.000471	-0.001058	-0.002653	-0.004548	-0.005414
0.00	-0.000527	-0.000887	-0.000959	-0.001537	-0.000339	-0.005809	-0.008148	-0.008829	-0.004538	-0.004314
-1.50	-0.000819	-0.000529	-0.000888	-0.001360	-0.002070	-0.007176	-0.011498	-0.003281	-0.005658	-0.007487
-2.50	-0.000880	-0.001037	-0.001193	-0.001110	-0.002660	-0.004932	-0.005419	-0.005215	-0.010575	-0.009248
-3.25	-0.000122	-0.000481	-0.000145	-0.000523	-0.000493	-0.002770	-0.001006	-0.008163	-0.012333	-0.010308
-4.00	-0.000453	-0.001442	-0.001088	-0.000789	-0.000221	-0.003363	-0.005259	-0.009404	-0.009754	-0.007297
-5.50	-0.000956	-0.001497	-0.000893	-0.001557	-0.000156	-0.000618	-0.002373	-0.004220	-0.004146	-0.004920

Force and Moment Summary

Balance h/De =	33.67	17.55	11.68	8.77	5.83	4.67	3.49	2.33	1.73	1.16
Balance Al/T =	-0.013	-0.015	-0.018	-0.023	-0.004	0.010	0.011	-0.017	-0.056	-0.115
Pressure Balance Al/T =	-0.010	-0.019	-0.017	-0.027	-0.010	0.009	0.014	-0.003	-0.042	-0.078
Pressure Balance AM/TDe =	-0.002	0.006	-0.011	-0.014	-0.045	-0.053	-0.065	-0.024	-0.001	0.050
Pressure Balance AM/TDe =	-0.002	0.006	-0.004	-0.005	-0.042	-0.064	-0.085	-0.042	0.012	0.046

Jet-Induced Pressure Increments  
Run 287

Point	1	2	3	4	5	6	7	8
h/De =	17.54	11.68	8.77	5.83	4.67	3.49	2.32	1.74
Total Throat =	136.13	136.07	135.94	135.88	135.91	136.01	135.98	135.94
NPR Front =	4.01	4.01	4.01	4.01	4.01	4.01	4.01	4.01
NPR Aft =	3.80	3.79	3.79	3.79	3.79	3.79	3.79	3.78
X-loc	ACP	ACP	ACP	ACP	ACP	ACP	ACP	ACP
Y-loc	ACP	ACP	ACP	ACP	ACP	ACP	ACP	ACP
Point	17.54	11.68	8.77	5.83	4.67	3.49	2.32	1.74
h/De =	136.13	136.07	135.94	135.88	135.91	136.01	135.98	135.94
Total Throat =	4.01	4.01	4.01	4.01	4.01	4.01	4.01	4.01
NPR Front =	3.80	3.79	3.79	3.79	3.79	3.79	3.79	3.78
NPR Aft =	ACP	ACP	ACP	ACP	ACP	ACP	ACP	ACP
X-loc	ACP	ACP	ACP	ACP	ACP	ACP	ACP	ACP
Y-loc	ACP	ACP	ACP	ACP	ACP	ACP	ACP	ACP
Force and Moment Summary								
Balance	17.54	11.68	8.77	5.83	4.67	3.49	2.32	1.74
Pressure	AL/T =	-0.010	-0.018	0.012	0.019	0.014	-0.018	-0.048
Balance	AL/T =	-0.010	-0.016	0.007	0.020	0.026	-0.002	-0.035
Pressure	ΔM/TDe =	-0.010	-0.005	-0.010	-0.040	-0.047	-0.041	-0.035
Balance	ΔM/TDe =	-0.002	-0.001	0.001	-0.040	-0.058	-0.031	0.006

Jet-Induced Pressure Increments  
 Configuration: IC-8-2.5/3.9-12/8 Run 288

Point	1	2	3	4	5	6	7	8
h/De =	17.53	11.68	8.76	5.84	4.66	3.48	2.30	1.73
Total Thrust =	220.58	220.33	220.38	220.23	220.23	220.25	220.24	220.22
NPR Front =	5.99	5.99	5.99	5.99	5.99	5.99	5.98	5.98
NPR Aft =	5.67	5.67	5.68	5.67	5.67	5.67	5.67	5.67
X-loc	ACP	ACP	ACP	ACP	ACP	ACP	ACP	ACP
-4.00	-0.000888	-0.001355	-0.001002	-0.004601	-0.007630	-0.013322	-0.018552	-0.007942
-4.00	-0.000222	-0.000818	-0.000880	-0.001506	-0.003894	-0.006894	-0.008803	-0.005335
-4.00	-0.000346	-0.000654	-0.000733	-0.000372	-0.001782	-0.004596	-0.006043	-0.004430
-4.00	-0.001885	-0.001606	-0.001827	-0.006067	-0.010104	-0.013916	-0.015670	-0.004587
-4.00	-0.001831	-0.001179	-0.001564	-0.004376	-0.007558	-0.010024	-0.010703	-0.000755
-4.00	-0.000353	-0.000729	-0.000822	-0.000224	-0.001284	-0.004238	-0.006214	-0.003445
-4.00	-0.001188	-0.001180	-0.001680	-0.003894	-0.005572	-0.008931	-0.009566	-0.002264
-4.00	-0.001303	-0.000772	-0.001563	-0.003429	-0.005601	-0.008007	-0.007519	-0.002802
4.00	-0.000809	-0.001289	-0.001324	-0.001332	-0.001856	-0.002689	-0.002228	-0.004798
4.75	-0.000651	-0.001137	-0.001409	-0.001547	-0.002348	-0.003636	-0.003911	-0.005633
4.00	-0.001369	-0.000929	-0.001497	-0.003060	-0.005359	-0.008650	-0.007467	-0.004160
3.25	-0.000986	-0.000700	-0.001478	-0.002626	-0.004239	-0.006695	-0.008074	-0.000987
2.50	-0.000336	-0.000423	-0.001107	-0.001563	-0.001932	-0.002572	-0.003116	-0.000813
1.50	-0.000102	-0.000230	-0.000949	-0.001172	-0.000877	-0.000006	-0.001116	-0.002212
0.75	-0.000063	-0.000333	-0.000901	-0.000788	-0.002861	-0.004564	-0.006972	-0.010044
0.00	-0.000025	-0.000595	-0.000613	-0.002133	-0.004487	-0.008305	-0.015150	-0.019981
-0.75	-0.000001	-0.000322	-0.000571	-0.002163	-0.006135	-0.012603	-0.021375	-0.027267
-0.50	-0.000001	-0.000196	-0.000651	-0.002721	-0.006285	-0.012500	-0.021104	-0.019230
-3.50	-0.000050	-0.000361	-0.000486	-0.002574	-0.004980	-0.007306	-0.006316	-0.002871
-3.25	-0.000170	-0.000988	-0.000534	-0.000852	-0.001268	-0.000805	-0.001849	-0.001390
-4.00	-0.000578	-0.001088	-0.000565	-0.000230	-0.000999	-0.003045	-0.005177	-0.004217
-4.00	-0.000700	-0.001263	-0.000973	-0.001136	-0.004757	-0.007780	-0.003671	-0.003220
-4.00	-0.000582	-0.000944	-0.001442	-0.002551	-0.004255	-0.005071	-0.008532	-0.006648
3.25	-0.00378	-0.00662	-0.001223	-0.001578	-0.001174	-0.003330	-0.005933	-0.000851
4.00	-0.00111	-0.000828	-0.000796	-0.001406	-0.001393	-0.003036	-0.001600	-0.001199
-4.00	-0.000091	-0.000819	-0.000505	-0.000948	-0.003036	-0.006249	-0.003064	-0.000648
-4.25	-0.000591	-0.001196	-0.000505	-0.000488	-0.007819	-0.011924	-0.011002	-0.002095
3.25	-0.000758	-0.000887	-0.001623	-0.002468	-0.003399	-0.004825	-0.006601	-0.000078
3.50	-0.000758	-0.000595	-0.000587	-0.001096	-0.002575	-0.004825	-0.006601	-0.000078
2.50	-0.000197	-0.000791	-0.000587	-0.001185	-0.004357	-0.007078	-0.005979	-0.000498
-5.50	-0.000171	-0.000411	-0.001037	-0.000250	-0.000611	-0.002361	-0.003774	-0.004100
-4.00	-0.002013	-0.001549	-0.001916	-0.001554	-0.001519	-0.015972	-0.016537	-0.002556
3.25	-0.000191	-0.000574	-0.001001	-0.001566	-0.004293	-0.007725	-0.009734	-0.003393
3.50	-0.000762	-0.000471	-0.001253	-0.001592	-0.001399	-0.002815	-0.004203	-0.002210
-4.00	-0.000665	-0.000957	-0.000781	-0.002051	-0.002104	-0.003315	-0.006259	-0.001776
-4.00	-0.000791	-0.000767	-0.001352	-0.001923	-0.004587	-0.001762	-0.000040	-0.001791
3.25	-0.000737	-0.000921	-0.001447	-0.001080	-0.000441	-0.016012	-0.019370	-0.011121
3.50	-0.000680	-0.000786	-0.001182	-0.000592	-0.000804	-0.000226	-0.000420	-0.002602
-5.50	-0.000346	-0.000635	-0.000587	-0.003185	-0.004357	-0.002466	-0.005911	-0.003113
3.25	-0.000704	-0.000621	-0.000870	-0.000400	-0.000843	-0.000708	-0.005979	-0.000498
3.50	-0.000346	-0.000621	-0.000870	-0.000400	-0.000843	-0.000708	-0.005979	-0.000498
3.25	-0.000687	-0.000635	-0.001612	-0.001371	-0.000658	-0.003301	-0.004183	-0.000768
3.50	-0.000487	-0.000491	-0.001612	-0.001371	-0.000658	-0.003301	-0.004183	-0.000768
4.00	-0.000791	-0.001167	-0.001245	-0.001244	-0.001285	-0.002347	-0.004021	-0.004002
3.25	-0.000849	-0.001115	-0.001629	-0.001368	-0.001860	-0.002493	-0.002937	-0.006334
3.50	-0.000595	-0.000735	-0.001209	-0.000984	-0.000228	-0.000219	-0.001289	-0.007573
2.50	-0.000347	-0.000700	-0.001144	-0.000784	-0.000482	-0.002043	-0.005243	-0.005260
1.50	-0.000070	-0.000388	-0.000529	-0.000319	-0.000152	-0.001163	-0.002041	-0.001390
0.00	-0.000218	-0.000663	-0.000770	-0.003127	-0.005815	-0.010188	-0.017341	-0.019962
-1.50	-0.000321	-0.001063	-0.000770	-0.003127	-0.005815	-0.010188	-0.017341	-0.019962
-2.50	-0.000751	-0.001022	-0.001059	-0.001145	-0.005925	-0.010352	-0.015290	-0.004907
-3.25	-0.000705	-0.000746	-0.001041	-0.002828	-0.005495	-0.010352	-0.015290	-0.004907
3.25	-0.000379	-0.000675	-0.001313	-0.001545	-0.002455	-0.002810	-0.005784	-0.009479
4.00	-0.000787	-0.000997	-0.001479	-0.001325	-0.001288	-0.002009	-0.005250	-0.006392
4.00	-0.001095	-0.001091	-0.001437	-0.002730	-0.012380	-0.014949	-0.018504	-0.009406
3.25	-0.000643	-0.000957	-0.001415	-0.002730	-0.006446	-0.011452	-0.014645	-0.007091
2.00	-0.000674	-0.000962	-0.001151	-0.001018	-0.002646	-0.004245	-0.008203	-0.009552
2.00	-0.000887	-0.000982	-0.000788	-0.003170	-0.000937	-0.002651	-0.004384	-0.004749
-2.50	-0.000712	-0.001165	-0.000982	-0.003097	-0.006163	-0.008277	-0.005295	-0.003330
-5.50	-0.000805	-0.001041	-0.001070	-0.001668	-0.000655	-0.002379	-0.004639	-0.004903
-4.00	-0.001187	-0.001619	-0.001489	-0.005487	-0.013388	-0.025551	-0.025974	-0.016730
5.50	-0.000453	-0.000662	-0.001415	-0.001064	-0.001774	-0.002210	-0.002772	-0.003361

Force and Moment Summary

Balance h/De =	17.53	11.68	8.76	5.84	4.66	3.48	2.30	1.73
Pressure AL/T =	-0.009	-0.011	-0.017	0.002	0.019	0.015	-0.008	-0.018
Balance AL/T =	-0.011	-0.016	-0.022	0.006	0.013	0.017	-0.007	-0.008
Pressure AH/TDe =	0.000	0.001	-0.004	-0.022	-0.026	-0.029	-0.008	0.019
Pressure AH/TDe =	-0.002	-0.002	-0.007	-0.033	-0.043	-0.045	-0.032	0.007

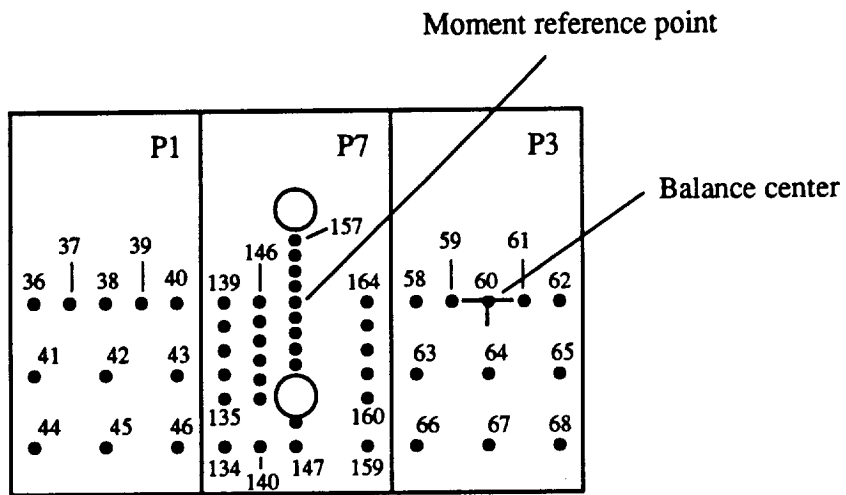

Figure 81. Configuration 2C\_0\_3.9\_12/8;  $D_e = 1.216 \text{ in.}$ ,  $A_{jet} = 1.16 \text{ in.}^2$ .

Pressure Orifice Locations and Weighting Factors

Conf. # 2C-0-3.9-12/8

Distance from balance center to moment reference point,  $X_0 = -4$

Orif. #	Mom. arm	Sta. y	$\Delta$ .Area	Sta. x
58	-2.5	0	1.313	-2.5
59	-3.25	0	1.125	-3.25
60	-4	0	1.125	-4
61	-4.75	0	1.125	-4.75
62	-5.5	0	1.313	-5.5
63	-2.5	1.5	3.75	-2.5
64	-4	1.5	4.5	-4
65	-5.5	1.5	3.75	-5.5
66	-2.5	3	4.375	-2.5
67	-4	3	5.25	-4
68	-5.5	3	4.375	-5.5
134	1.56	3	3.063	1.5
135	1.56	2	0.875	1.5
136	1.56	1.5	0.875	1.5
137	1.56	1	0.875	1.5
138	1.56	0.5	0.875	1.5
139	1.56	0	0.438	1.5
140	0.75	3	2.625	0.75
141	0.75	2	0.534	0.75
142	0.75	1.6	0.575	0.75
143	0.75	1.2	0.6	0.75
144	0.75	0.8	0.6	0.75
145	0.75	0.4	0.6	0.75
146	0.75	0	0.3	0.75
147	0	3	2.006	0
148	0	2.5	0.54	0
149	0	1.3	0.54	0
150	0	0.975	0.488	0
151	0	0.65	0.488	0
152	0	0.325	0.488	0
153	0	0	0.432	0
154	0	-0.325	0	0
155	0	-0.65	0	0
156	0	-0.975	0	0
157	0	-1.3	0	0
159	-1.19	3	5.688	-1.5
160	-1.163	2	1.559	-1.5
161	-1.163	1.5	1.6	-1.5
162	-1.163	1	1.625	-1.5
163	-1.163	0.5	1.625	-1.5
164	-1.5	0	0.626	-1.5
36	5.5	0	1.313	5.5
37	4.75	0	1.125	4.75
38	4	0	1.125	4
39	3.25	0	1.125	3.25
40	2.5	0	1.313	2.5

Conf. # 2C\_0\_3.9\_12/8, continued

Orif. #	Mom. arm	Sta. y	$\Delta$ .Area	Sta. x
41	5.5	1.5	3.75	5.5
42	4	1.5	4.5	4
43	2.5	1.5	3.75	2.5
44	5.5	3	4.375	5.5
45	4	3	5.25	4
46	2.5	3	4.375	2.5

Jet-Induced Pressure Increments  
Run 289

Point	1	2	3	4	5	6	7	8	9	
Total Thrust =	47.39	24.70	16.46	3.24	1.62	2.43	6.29	8.22	4.94	
NFR Front =	25.84	26.52	1.00	1.00	1.00	1.00	1.00	1.00	26.69	
NFR Alt =	1.93	1.96	1.96	1.96	1.95	1.96	1.96	1.97	1.97	
X-loc	Y-loc	ACP	ACP	ACP	ACP	ACP	ACP	ACP	ACP	
0.00	-1.30	-0.000800	-0.000524	-0.000849	0.005107	-0.002187	0.002552	-0.001835	-0.001551	0.000735
0.00	-0.98	-0.000287	-0.000110	-0.000435	0.006890	-0.011051	0.003100	-0.001442	-0.000842	-0.000318
0.00	-0.65	-0.000185	-0.000070	-0.000335	0.008951	-0.004430	0.008758	-0.001477	-0.000580	0.000382
0.00	-0.32	-0.000087	-0.000035	-0.000166	0.011366	-0.002506	0.016276	-0.002069	-0.000307	0.000422
5.50	0.00	-0.000191	-0.000216	-0.000261	0.000928	-0.001000	0.000130	-0.000856	-0.000554	0.000255
4.75	0.00	-0.000160	-0.000241	-0.000261	0.000958	-0.000505	0.000236	-0.001216	-0.000514	0.000124
4.00	0.00	-0.000119	-0.000136	-0.000086	0.001542	-0.000934	0.000145	-0.001081	-0.000409	0.001124
3.25	0.00	-0.000114	-0.000120	-0.000101	0.003387	-0.001975	0.001465	-0.001256	-0.000394	0.000525
2.50	0.00	-0.000103	-0.000120	-0.000086	0.004280	-0.001975	0.004034	-0.000956	-0.000299	0.000984
1.50	0.00	-0.000154	-0.000055	-0.000110	0.019188	-0.004891	0.002911	-0.001124	-0.000337	0.000154
0.75	0.00	-0.000077	-0.000289	-0.000610	0.034795	-0.014492	0.014492	-0.001805	-0.000347	0.000099
0.00	0.00	-0.000051	-0.000120	-0.000135	0.033519	-0.015582	0.015582	-0.002149	-0.000337	0.000407
-1.50	0.00	-0.000082	-0.000105	-0.000340	0.005388	-0.012730	0.007003	-0.001193	-0.000367	0.001196
-2.50	0.00	-0.000129	-0.000166	-0.000146	0.001305	-0.001732	0.001781	-0.001582	-0.000359	0.001983
-3.25	0.00	-0.000170	-0.000266	-0.000236	0.001781	-0.001732	0.001781	-0.001582	-0.000359	0.001983
-4.00	0.00	-0.000139	-0.000291	-0.000302	0.000242	-0.001161	0.000627	-0.001176	-0.000648	0.001649
-4.75	0.00	-0.000124	-0.000246	-0.000498	0.000717	-0.000783	0.000783	-0.001262	-0.000748	0.000580
-5.50	0.00	-0.000124	-0.000246	-0.000498	0.000151	-0.000717	0.000848	-0.001366	-0.000803	0.000330
0.75	0.40	-0.000062	-0.000329	-0.000215	0.050113	-0.022839	0.011590	-0.002183	-0.000332	0.000313
1.50	0.50	-0.000144	-0.000085	-0.000140	0.016988	-0.012361	0.010261	-0.001766	-0.000768	0.000318
2.50	0.50	-0.000077	-0.000105	-0.000260	0.003374	-0.001756	0.000374	-0.001094	-0.000287	0.000382
0.00	0.65	-0.000164	-0.000289	-0.000664	0.010321	-0.000882	0.000882	-0.001254	-0.000411	0.000315
0.75	0.80	-0.000201	-0.000294	-0.000579	0.015557	-0.000773	0.000264	-0.001721	-0.000778	0.000452
1.50	1.00	-0.000523	-0.000359	-0.000629	0.003905	-0.002900	0.002826	-0.001865	-0.000991	0.000859
2.50	1.00	-0.000144	-0.000085	-0.000140	0.017360	-0.002794	0.006126	-0.001254	-0.000411	0.000315
-1.50	1.00	-0.000108	-0.000140	-0.000205	0.041111	-0.026744	0.001669	-0.001169	-0.000317	0.000094
0.75	1.20	-0.000095	-0.000269	-0.000565	0.041136	-0.021961	0.005079	-0.001691	-0.000753	0.000591
1.30	1.00	-0.000523	-0.000359	-0.000629	0.003095	-0.002900	0.002826	-0.001865	-0.000991	0.000859
5.50	1.50	-0.000155	-0.000241	-0.000282	0.020291	-0.004211	0.003356	-0.001406	-0.000519	0.000150
4.00	1.50	-0.000144	-0.000266	-0.000236	0.003735	-0.011712	0.005996	-0.001051	-0.000384	0.000050
2.50	1.50	-0.000129	-0.000161	-0.000121	0.058932	-0.019146	0.009416	-0.001035	-0.000461	0.000354
1.50	1.50	-0.000021	-0.000165	-0.000190	0.068510	-0.024653	0.009416	-0.001035	-0.000461	0.000354
1.50	1.50	-0.000118	-0.000230	-0.000206	0.068510	-0.024653	0.009416	-0.001035	-0.000461	0.000354
-2.50	1.50	-0.000175	-0.000226	-0.000332	0.04304	-0.009446	0.006147	-0.000891	-0.000444	0.001354
-5.50	1.50	-0.000051	-0.000235	-0.000535	0.06840	-0.026325	0.014206	-0.001626	-0.000723	0.002536
1.50	2.00	-0.000236	-0.000334	-0.000250	0.08057	-0.020536	0.016800	-0.000865	-0.000813	0.003867
0.75	2.00	-0.000010	-0.000254	-0.000505	0.11607	-0.022436	0.016829	-0.001453	-0.000733	0.003227
-1.50	2.00	-0.000072	-0.000220	-0.000475	0.07396	-0.018222	0.011068	-0.001686	-0.001155	0.001276
0.00	2.50	-0.000093	-0.000296	-0.000649	0.08432	-0.021372	0.011977	-0.001865	-0.000540	0.003887
5.50	3.00	-0.000108	-0.000362	-0.000302	0.03438	-0.026196	0.002674	-0.000776	-0.00038	0.000919
4.00	3.00	-0.000181	-0.000442	-0.000357	0.05484	-0.025424	0.005008	-0.000771	-0.000474	0.000899
2.50	3.00	-0.000287	-0.000454	-0.000530	0.07572	-0.019392	0.009652	-0.001293	-0.000933	0.001389
0.75	3.00	-0.000056	-0.000344	-0.000530	0.07832	-0.012635	0.007322	-0.001517	-0.000723	0.003093
0.00	3.00	-0.000103	-0.000374	-0.000634	0.06305	-0.012054	0.010063	-0.001815	-0.000461	0.003361
-1.50	3.00	-0.000318	-0.000482	-0.000599	0.06680	-0.009697	0.009232	-0.001696	-0.001110	0.001882
-4.50	3.00	-0.000196	-0.000412	-0.000639	0.05403	-0.009593	0.005403	-0.001072	-0.001187	0.002808
-5.50	3.00	-0.000134	-0.000291	-0.000583	0.03675	-0.004257	0.003492	-0.000440	-0.000293	0.002293
-5.50	3.00	-0.000258	-0.000296	-0.000352	0.001955	-0.002182	0.002182	-0.001196	-0.000948	0.000630

Force and Moment Summary  
 h/Dm = 47.39 24.70 16.46 3.24 1.62 2.43 6.29 8.22 4.94  
 Balance AL/T = 0.001 -0.004 -0.116 -0.308 -0.188 -0.047 -0.038 -0.054  
 Pressure AL/T = -0.006 -0.015 -0.046 -0.141 -0.097 -0.046 -0.036 -0.061  
 Balance AM/Tm = 0.002 -0.011 -0.036 -0.073 -0.081 -0.048 0.006 -0.022  
 Pressure AM/Tm = 0.002 -0.000 0.009 0.022 -0.034 -0.011 -0.002 0.006 0.030



Jet-Induced Pressure Increments  
 Configuration: 2C-0-3.9-12/8  
 Run 290

Point	1	2	3	4	5	6	7	8	9
Total Thrust =	47.33	24.66	16.45	12.32	8.21	6.58	4.94	3.29	2.46
NPR Front =	68.09	67.88	67.95	67.98	67.96	67.86	67.78	67.73	67.73
NPR Aft =	1.00	1.00	1.00	1.00	1.00	1.00	1.00	1.00	1.00
X-loc	3.81	3.80	3.80	3.80	3.80	3.80	3.79	3.79	3.79
Y-loc	ACP	ACP	ACP	ACP	ACP	ACP	ACP	ACP	ACP
0.00	-0.000655	-0.000441	-0.000719	-0.000481	-0.000659	-0.001562	0.004433	0.007940	0.004433
0.00	-0.001111	-0.000246	-0.000133	-0.000411	-0.000326	-0.001066	0.000792	0.004214	0.005648
0.00	-0.00045	-0.00035	-0.000140	-0.00057	-0.00070	-0.001093	0.001098	0.005614	0.010839
0.00	-0.00137	0.00074	0.00055	-0.00111	0.00039	-0.000918	0.00072	0.006907	0.014876
5.50	0.00	-0.00145	-0.000114	-0.000224	-0.000489	-0.000979	-0.000775	0.000045	-0.000585
4.75	0.00	-0.00104	-0.00130	-0.000220	-0.000837	-0.000485	-0.000837	-0.000047	-0.000563
4.00	0.00	-0.00098	-0.00104	-0.00086	-0.000596	-0.000502	-0.001141	-0.000835	-0.000199
3.25	0.00	-0.00020	-0.00010	-0.00015	-0.00016	-0.00030	-0.001224	0.000018	0.001026
2.50	0.00	-0.00024	-0.00045	-0.00010	-0.00132	-0.000713	-0.001078	0.000108	0.004447
1.50	0.00	-0.00025	-0.00021	-0.00070	-0.00111	-0.001207	-0.001083	0.001561	0.001939
0.75	0.00	-0.00062	-0.00096	-0.00014	-0.00023	-0.000568	-0.000301	0.005053	0.011672
0.00	0.00008	0.00029	-0.00078	-0.00078	-0.00159	-0.001109	-0.000752	0.007295	0.015353
-1.50	0.00	-0.00037	-0.00134	-0.00082	-0.00147	-0.00183	-0.001047	-0.001850	0.000930
-2.50	0.00	-0.00019	-0.00143	-0.00028	-0.00028	-0.000493	-0.001026	-0.000908	0.000930
-4.00	0.00	-0.00036	-0.00210	-0.00029	-0.00042	-0.00055	-0.001442	-0.000892	-0.001514
-4.75	0.00	-0.00197	-0.00204	-0.00027	-0.00057	-0.000991	-0.001118	-0.000581	-0.001703
-5.50	0.00	-0.00158	-0.00231	-0.00029	-0.00059	-0.001123	-0.000885	0.004389	0.009665
0.00	0.32	-0.00030	-0.00042	-0.00056	-0.00440	-0.001269	-0.000203	0.003296	0.007816
0.75	0.40	-0.00029	-0.00022	-0.00013	-0.00051	-0.00320	-0.001271	-0.002111	-0.001508
1.50	0.50	-0.00058	-0.00074	-0.00018	-0.00136	-0.00191	-0.001546	-0.000917	-0.004541
3.00	0.50	-0.00154	-0.00160	-0.00193	-0.00137	-0.00153	-0.002442	-0.000288	0.001348
0.75	0.80	-0.00048	-0.00044	-0.00056	-0.00411	-0.00130	-0.001513	-0.001722	0.001381
0.00	0.98	-0.00029	-0.00064	-0.00113	-0.00051	-0.00320	-0.002111	-0.001508	-0.004541
1.50	1.00	-0.00115	-0.00271	-0.00131	-0.00058	-0.001058	-0.002713	-0.002518	-0.005306
3.00	1.20	-0.00047	-0.00419	-0.00050	-0.00077	-0.001019	-0.003222	-0.001841	-0.005474
0.00	1.30	-0.00048	-0.00419	-0.00055	-0.00067	-0.00153	-0.002565	-0.001903	-0.002469
0.75	1.50	-0.00125	-0.00187	-0.00029	-0.00186	-0.000931	-0.001753	-0.001918	-0.003233
1.50	1.50	-0.00078	-0.00039	-0.00130	-0.00042	-0.000964	-0.002030	-0.003820	-0.006518
3.00	1.50	-0.00074	-0.00071	-0.00106	-0.00193	-0.000981	-0.002540	-0.004925	-0.008450
4.00	1.50	-0.00148	-0.00031	-0.00201	-0.00138	-0.00138	-0.002471	-0.004232	-0.007595
-1.50	1.50	-0.00090	-0.00018	-0.00216	-0.00047	-0.00182	-0.002575	-0.004455	-0.008350
-2.50	1.50	-0.00170	-0.00120	-0.00349	-0.00054	-0.00105	-0.002452	-0.003944	-0.005079
-5.00	1.50	-0.00043	-0.00192	-0.00030	-0.00081	-0.00079	-0.001150	-0.001723	-0.003034
0.75	2.00	-0.00159	-0.00182	-0.00050	-0.00075	-0.00112	-0.001268	-0.005157	-0.010439
1.75	2.00	-0.00155	-0.00183	-0.00029	-0.00068	-0.00108	-0.003368	-0.006270	-0.009379
3.00	2.00	-0.00033	-0.00269	-0.00045	-0.00093	-0.00142	-0.003988	-0.005570	-0.009103
5.00	2.00	-0.00081	-0.00094	-0.00025	-0.00041	-0.00078	-0.001138	-0.00189	-0.002771
3.00	3.00	-0.00131	-0.00138	-0.00056	-0.00052	-0.00077	-0.001137	-0.00189	-0.002491
4.00	3.00	-0.00027	-0.00307	-0.00039	-0.00052	-0.00054	-0.00056	-0.00056	-0.00056
1.50	3.00	-0.000175	-0.000472	-0.00067	-0.00052	-0.00052	-0.00052	-0.00052	-0.00052
0.75	3.00	-0.000278	-0.00008	-0.00052	-0.00043	-0.00039	-0.00039	-0.00039	-0.00039
-1.50	3.00	-0.000220	-0.00005	-0.00035	-0.00035	-0.00035	-0.00035	-0.00035	-0.00035
-2.50	3.00	-0.000317	-0.00005	-0.00044	-0.00044	-0.00044	-0.00044	-0.00044	-0.00044
-4.00	3.00	-0.000192	-0.000192	-0.000192	-0.000192	-0.000192	-0.000192	-0.000192	-0.000192
-5.50	3.00	-0.000170	-0.000236	-0.000367	-0.000536	-0.000983	-0.001768	-0.002302	-0.002302

Force and Moment Summary

h/Dc =	47.33	24.66	16.45	12.32	8.21	6.58	4.94	3.29	2.46
Balance AL/T =	-0.007	-0.008	-0.013	-0.017	-0.027	-0.041	-0.059	-0.109	-0.178
Pressure AL/T =	-0.007	-0.008	-0.012	-0.015	-0.026	-0.047	-0.087	-0.118	-0.182
Balance AH/TDe =	0.021	0.024	0.032	0.030	0.026	0.016	0.005	0.008	0.010
Pressure AH/TDe =	0.002	0.003	0.006	0.009	0.004	0.001	0.004	0.004	0.002

Configuration: 2C-0-3.9-12/8 Jet-Induced Pressure Increments Run 291

Point	1	2	3	4	5	6	7	8
Total Thrust =	24.69	16.48	12.37	8.23	6.60	4.96	3.30	2.46
NPR Front =	109.67	109.67	109.67	109.61	109.53	109.48	109.43	109.41
NPR Aft =	1.00	1.00	1.00	1.00	1.00	1.00	1.00	1.00
ACP	5.68	5.68	5.67	5.67	5.67	5.66	5.66	5.66
Y-loc	ACP	ACP	ACP	ACP	ACP	ACP	ACP	ACP
0.00	-0.000308	-0.000329	-0.000669	-0.000813	-0.001311	-0.000200	0.008059	0.014099
0.00	-0.000258	-0.000396	-0.000489	-0.000881	-0.000881	-0.000491	0.007944	0.010816
0.00	-0.00107	-0.000139	-0.000215	-0.000216	-0.000627	-0.000368	0.007050	0.013609
0.00	-0.32	-0.000095	-0.000149	-0.000169	-0.000628	-0.000905	0.006579	0.016233
5.50	0.00	-0.00079	-0.000113	-0.000141	-0.000482	-0.001662	-0.000518	-0.000518
4.75	0.00	-0.00083	-0.000113	-0.000198	-0.000455	-0.000879	-0.001592	-0.001958
4.00	0.00	-0.00047	-0.000102	-0.000078	-0.000445	-0.000644	-0.001305	-0.002134
3.25	0.00	-0.00023	-0.000056	-0.000063	-0.000246	-0.000578	-0.001424	-0.001170
2.50	0.00	-0.00045	-0.000050	-0.000036	-0.000179	-0.000578	-0.001731	-0.000896
1.50	0.00	-0.00085	-0.000050	-0.000035	-0.000139	-0.000696	-0.001692	-0.000809
0.75	0.00	-0.00011	-0.000095	-0.000092	-0.000168	-0.000788	-0.001403	-0.003135
0.00	-0.00041	-0.000059	-0.000134	-0.000206	-0.000576	-0.001031	-0.004067	-0.014435
-1.50	0.00	-0.00021	-0.000077	-0.000186	-0.000204	-0.000646	-0.000922	-0.002058
-2.50	0.00	-0.00086	-0.000116	-0.000154	-0.000152	-0.000774	-0.001511	-0.000931
-3.25	0.00	-0.00088	-0.000116	-0.000154	-0.000152	-0.000774	-0.001511	-0.000931
-4.00	0.00	-0.00102	-0.000123	-0.000300	-0.000409	-0.000815	-0.001415	-0.002471
-4.75	0.00	-0.00142	-0.000170	-0.000315	-0.000595	-0.000946	-0.001576	-0.000882
-5.50	0.00	-0.00196	-0.000248	-0.000321	-0.000552	-0.000946	-0.001547	-0.000925
0.00	0.32	0.00098	-0.000173	-0.000083	-0.000178	-0.000758	-0.001144	-0.002056
0.75	0.40	0.00016	-0.000182	-0.000095	-0.000271	-0.000846	-0.001311	-0.001351
1.50	0.50	-0.00060	-0.00045	-0.000103	-0.000209	-0.000708	-0.001618	-0.002794
0.75	0.80	-0.00068	-0.00042	-0.000239	-0.000185	-0.000715	-0.001357	-0.000471
1.50	0.50	-0.00281	-0.00042	-0.000239	-0.000237	-0.001026	-0.001617	-0.001234
0.75	0.80	-0.00115	-0.00008	-0.000092	-0.000317	-0.000801	-0.000694	-0.000412
0.00	0.98	-0.00040	-0.000531	-0.000477	-0.000752	-0.001501	-0.002381	-0.003108
1.50	1.00	-0.00063	-0.000184	-0.000534	-0.000103	-0.000771	-0.001618	-0.003626
-1.50	1.00	-0.000157	-0.000184	-0.000238	-0.000409	-0.000928	-0.001469	-0.002352
0.75	1.20	-0.000485	-0.000251	-0.000477	-0.000752	-0.001501	-0.001934	-0.005145
0.00	1.30	-0.000470	-0.000251	-0.000477	-0.000752	-0.001501	-0.002381	-0.006151
5.50	1.50	-0.00051	-0.000122	-0.000165	-0.000194	-0.000797	-0.001464	-0.003717
4.00	1.50	-0.00068	-0.000078	-0.000091	-0.000388	-0.000740	-0.001254	-0.002998
2.50	1.50	-0.00035	-0.000069	-0.000063	-0.000234	-0.000566	-0.001312	-0.004076
1.50	1.50	-0.00076	-0.000111	-0.000130	-0.000462	-0.000763	-0.001426	-0.007776
-2.50	1.50	-0.00049	-0.000118	-0.000148	-0.000458	-0.000846	-0.001727	-0.004501
-5.50	1.50	-0.00045	-0.000300	-0.000301	-0.000356	-0.000750	-0.001764	-0.004374
-4.00	1.50	-0.00045	-0.000105	-0.000221	-0.000540	-0.000771	-0.001894	-0.004374
0.75	1.50	-0.000307	-0.000460	-0.000442	-0.000549	-0.000828	-0.002139	-0.005097
1.50	2.00	-0.00034	-0.000187	-0.000391	-0.000560	-0.001167	-0.002126	-0.004974
0.75	2.00	-0.000249	-0.000253	-0.000545	-0.000899	-0.001457	-0.002722	-0.006110
-1.50	2.00	-0.000214	-0.000158	-0.000323	-0.000543	-0.000817	-0.002409	-0.005112
0.00	2.50	-0.000113	-0.000175	-0.000323	-0.000444	-0.000745	-0.001407	-0.003762
5.50	3.00	-0.00075	-0.000225	-0.000306	-0.000482	-0.001079	-0.001386	-0.002685
4.00	3.00	-0.000159	-0.000223	-0.000468	-0.000851	-0.001300	-0.002381	-0.003953
2.50	3.00	-0.000287	-0.000296	-0.000603	-0.000701	-0.001090	-0.002680	-0.004588
1.50	3.00	-0.00051	-0.000053	-0.000073	-0.000252	-0.000794	-0.002375	-0.004488
0.75	3.00	-0.000140	-0.000417	-0.001032	-0.000585	-0.000872	-0.002161	-0.004698
-1.50	3.00	-0.000276	-0.000318	-0.000628	-0.000770	-0.000913	-0.002166	-0.004728
-2.50	3.00	-0.000288	-0.000356	-0.000712	-0.001078	-0.002439	-0.002136	-0.006712
-4.00	3.00	-0.000194	-0.000340	-0.000431	-0.000732	-0.001169	-0.002149	-0.004387
-5.50	3.00	-0.000098	-0.000221	-0.000550	-0.000613	-0.000792	-0.001807	-0.003029

Force and Moment Summary

h/De =	24.69	16.48	12.37	8.23	6.60	4.96	3.30	2.46
Balance	Al/T =	-0.009	-0.013	-0.020	-0.030	-0.054	-0.100	-0.172
Pressure	Al/T =	-0.006	-0.015	-0.022	-0.036	-0.073	-0.122	-0.169
Balance	AN/TDe =	0.026	0.030	0.026	0.035	0.033	0.015	0.027
Pressure	AN/TDe =	0.004	0.005	0.010	0.002	0.017	-0.003	0.000

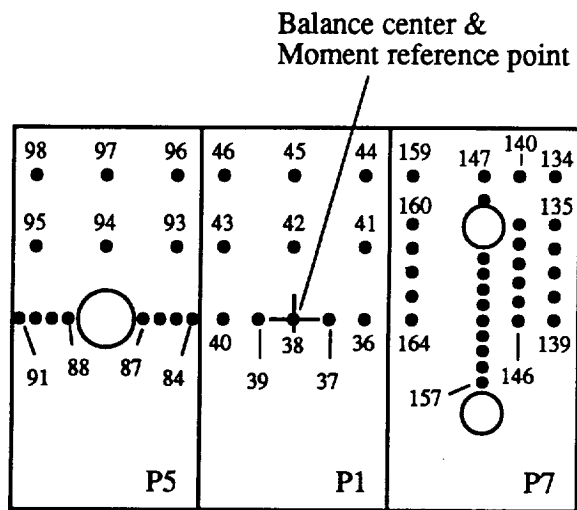

Figure 82. Configuration 3C\_8\_3.9\_12/8;  $D_e = 1.709$  in.,  $A_{jet} = 2.29$  in.<sup>2</sup>.

## Pressure Orifice Locations and Weighting Factors

Conf. # 3C-8-3.9-12/8

Distance from balance center to moment reference point,  $X_0 = 0$

Orif. #	Mom. arm	Sta. y	$\Delta$ .Area	Sta. x
134	-5.56	-3	3.063	-5.5
135	-5.56	-2	0.875	-5.5
136	-5.56	-1.5	0.875	-5.5
137	-5.56	-1	0.875	-5.5
138	-5.56	-0.5	0.875	-5.5
139	-5.56	0	0.438	-5.5
140	-4.75	-3	2.625	-4.75
141	-4.75	-2	0.534	-4.75
142	-4.75	-1.6	0.575	-4.75
143	-4.75	-1.2	0.6	-4.75
144	-4.75	-0.8	0.6	-4.75
145	-4.75	-0.4	0.6	-4.75
146	-4.75	0	0.3	-4.75
147	-4	-3	2.006	-4
148	-4	-2.5	0.54	-4
149	-4	-1.3	0.54	-4
150	-4	-0.975	0.488	-4
151	-4	-0.65	0.488	-4
152	-4	-0.325	0.488	-4
153	-4	0	0.244	-4
154	-4	0.325	0	-4
155	-4	0.65	0	-4
156	-4	0.975	0	-4
157	-4	1.3	0	-4
159	-2.81	-3	5.688	-2.5
160	-2.837	-2	1.559	-2.5
161	-2.837	-1.5	1.6	-2.5
162	-2.837	-1	1.625	-2.5
163	-2.837	-0.5	1.625	-2.5
164	-2.5	0	0.438	-2.5
36	-1.5	0	1.313	-1.5
37	-0.75	0	1.125	-0.75
38	0	0	1.125	0
39	0.75	0	1.125	0.75
40	1.5	0	1.313	1.5
41	-1.5	-1.5	3.75	-1.5
42	0	-1.5	4.5	0
43	1.5	-1.5	3.75	1.5
44	-1.5	-3	4.375	-1.5
45	0	-3	5.25	0
46	1.5	-3	4.375	1.5
84	2.15	0	0.634	2.15
85	2.5	0	0.683	2.5
86	2.85	0	0.683	2.85
87	3.2	0	0.619	3.2
88	4.8	0	0.619	4.8

Conf. # 3C\_8\_3.9\_12/8, continued

Orif. #	Mom. arm	Sta. y	$\Delta$ .Area	Sta. x
89	5.15	0	0.683	5.15
90	5.5	0	0.683	5.5
91	5.85	0	0.634	5.85
93	2.5	-1.5	3.19	2.5
94	4	-1.5	5.062	4
95	5.5	-1.5	3.19	5.5
96	2.5	-3	4.375	2.5
97	4	-3	5.25	4
98	5.5	-3	4.375	5.5

Jet-Induced Pressure Increments  
Run 232

Point	1	2	3	4	5	6	7	8	9	10
Total Thrust =	33.71	17.56	11.71	8.78	5.83	4.67	3.48	2.33	1.74	1.14
NPR Front =	53.75	54.30	52.78	52.64	52.60	52.60	52.62	52.66	52.66	52.66
NPR Aft =	2.12	2.13	2.05	2.05	2.05	2.05	2.05	2.05	2.05	2.05
X-loc	1.92	1.94	1.94	1.94	1.94	1.94	1.94	1.94	1.94	1.94
h/Da =	3.00	-3.00	-3.00	-3.00	-3.00	-3.00	-3.00	-3.00	-3.00	-3.00
AL/T =	0.000269	-0.000635	-0.000489	-0.000694	-0.002450	-0.003647	-0.005006	-0.007027	-0.008451	-0.009583
AL/T =	-0.000269	0.000635	0.000489	0.000694	0.002450	0.003647	0.005006	0.007027	0.008451	0.009583
AM/TDe =	0.000955	-0.001139	-0.001461	-0.002099	-0.002935	-0.003913	-0.004868	-0.005092	-0.005353	-0.005533
AM/TDe =	-0.000955	0.001139	0.001461	0.002099	0.002935	0.003913	0.004868	0.005092	0.005353	0.005533
AM/TDe =	0.000881	-0.000926	-0.001304	-0.001754	-0.002175	-0.002582	-0.002920	-0.003189	-0.003381	-0.003519
AM/TDe =	-0.000881	0.000926	0.001304	0.001754	0.002175	0.002582	0.002920	0.003189	0.003381	0.003519
AM/TDe =	0.000676	-0.000674	-0.000983	-0.001223	-0.001490	-0.001785	-0.002052	-0.002254	-0.002415	-0.002539
AM/TDe =	-0.000676	0.000674	0.000983	0.001223	0.001490	0.001785	0.002052	0.002254	0.002415	0.002539
AM/TDe =	0.000754	-0.000640	-0.000966	-0.001152	-0.001393	-0.001685	-0.001988	-0.002242	-0.002454	-0.002629
AM/TDe =	-0.000754	0.000640	0.000966	0.001152	0.001393	0.001685	0.001988	0.002242	0.002454	0.002629
AM/TDe =	0.001041	-0.001026	-0.001372	-0.001611	-0.001894	-0.002203	-0.002528	-0.002859	-0.003187	-0.003512
AM/TDe =	-0.001041	0.001026	0.001372	0.001611	0.001894	0.002203	0.002528	0.002859	0.003187	0.003512
AM/TDe =	0.000569	-0.000544	-0.000778	-0.001022	-0.001238	-0.001504	-0.001748	-0.002054	-0.002344	-0.002611
AM/TDe =	-0.000569	0.000544	0.000778	0.001022	0.001238	0.001504	0.001748	0.002054	0.002344	0.002611
AM/TDe =	0.001031	-0.001676	-0.002056	-0.002395	-0.002648	-0.002859	-0.003033	-0.003187	-0.003312	-0.003415
AM/TDe =	-0.001031	0.001676	0.002056	0.002395	0.002648	0.002859	0.003033	0.003187	0.003312	0.003415
AM/TDe =	0.000623	-0.001179	-0.001407	-0.001708	-0.002042	-0.002395	-0.002759	-0.003122	-0.003485	-0.003848
AM/TDe =	-0.000623	0.001179	0.001407	0.001708	0.002042	0.002395	0.002759	0.003122	0.003485	0.003848
AM/TDe =	0.000520	-0.000958	-0.001269	-0.001647	-0.002035	-0.002428	-0.002826	-0.003219	-0.003607	-0.003990
AM/TDe =	-0.000520	0.000958	0.001269	0.001647	0.002035	0.002428	0.002826	0.003219	0.003607	0.003990
AM/TDe =	0.000720	-0.000780	-0.001357	-0.001829	-0.002312	-0.002795	-0.003278	-0.003761	-0.004244	-0.004727
AM/TDe =	-0.000720	0.000780	0.001357	0.001829	0.002312	0.002795	0.003278	0.003761	0.004244	0.004727
AM/TDe =	0.000955	-0.001139	-0.001461	-0.002099	-0.002935	-0.003913	-0.004868	-0.005092	-0.005353	-0.005533
AM/TDe =	-0.000955	0.001139	0.001461	0.002099	0.002935	0.003913	0.004868	0.005092	0.005353	0.005533
AM/TDe =	0.001033	-0.001192	-0.001247	-0.001647	-0.002035	-0.002405	-0.002759	-0.003122	-0.003485	-0.003848
AM/TDe =	-0.001033	0.001192	0.001247	0.001647	0.002035	0.002405	0.002759	0.003122	0.003485	0.003848
AM/TDe =	0.000142	-0.000378	-0.000683	-0.001015	-0.001334	-0.001616	-0.001823	-0.002052	-0.002307	-0.002537
AM/TDe =	-0.000142	0.000378	0.000683	0.001015	0.001334	0.001616	0.001823	0.002052	0.002307	0.002537
AM/TDe =	0.000563	-0.000523	-0.000639	-0.000639	-0.000611	-0.000590	-0.000582	-0.000572	-0.000561	-0.000550
AM/TDe =	-0.000563	0.000523	0.000639	0.000639	0.000611	0.000590	0.000582	0.000572	0.000561	0.000550
AM/TDe =	0.000739	-0.000936	-0.001220	-0.001546	-0.001915	-0.002292	-0.002672	-0.003054	-0.003437	-0.003822
AM/TDe =	-0.000739	0.000936	0.001220	0.001546	0.001915	0.002292	0.002672	0.003054	0.003437	0.003822
AM/TDe =	0.000642	-0.001098	-0.001452	-0.001829	-0.002215	-0.002606	-0.002992	-0.003373	-0.003754	-0.004135
AM/TDe =	-0.000642	0.001098	0.001452	0.001829	0.002215	0.002606	0.002992	0.003373	0.003754	0.004135
AM/TDe =	0.001061	-0.001295	-0.001647	-0.002035	-0.002428	-0.002826	-0.003219	-0.003607	-0.003990	-0.004373
AM/TDe =	-0.001061	0.001295	0.001647	0.002035	0.002428	0.002826	0.003219	0.003607	0.003990	0.004373
AM/TDe =	0.000856	-0.000405	-0.000391	-0.000996	-0.001416	-0.001823	-0.002230	-0.002637	-0.003044	-0.003451
AM/TDe =	-0.000856	0.000405	0.000391	0.000996	0.001416	0.001823	0.002230	0.002637	0.003044	0.003451
AM/TDe =	0.000598	-0.000872	-0.001036	-0.001334	-0.001647	-0.001974	-0.002312	-0.002650	-0.002988	-0.003326
AM/TDe =	-0.000598	0.000872	0.001036	0.001334	0.001647	0.001974	0.002312	0.002650	0.002988	0.003326
AM/TDe =	0.001061	-0.001295	-0.001647	-0.002035	-0.002428	-0.002826	-0.003219	-0.003607	-0.003990	-0.004373
AM/TDe =	-0.001061	0.001295	0.001647	0.002035	0.002428	0.002826	0.003219	0.003607	0.003990	0.004373
AM/TDe =	0.000915	-0.000915	-0.001131	-0.001457	-0.001823	-0.002188	-0.002553	-0.002918	-0.003283	-0.003648
AM/TDe =	-0.000915	0.000915	0.001131	0.001457	0.001823	0.002188	0.002553	0.002918	0.003283	0.003648
AM/TDe =	0.001124	-0.000833	-0.001138	-0.001457	-0.001823	-0.002188	-0.002553	-0.002918	-0.003283	-0.003648
AM/TDe =	-0.001124	0.000833	0.001138	0.001457	0.001823	0.002188	0.002553	0.002918	0.003283	0.003648
AM/TDe =	0.000326	-0.000332	-0.000550	-0.000838	-0.001131	-0.001457	-0.001823	-0.002188	-0.002553	-0.002918
AM/TDe =	-0.000326	0.000332	0.000550	0.000838	0.001131	0.001457	0.001823	0.002188	0.002553	0.002918
AM/TDe =	0.000964	-0.000872	-0.001138	-0.001457	-0.001823	-0.002188	-0.002553	-0.002918	-0.003283	-0.003648
AM/TDe =	-0.000964	0.000872	0.001138	0.001457	0.001823	0.002188	0.002553	0.002918	0.003283	0.003648
AM/TDe =	0.000579	-0.000945	-0.001163	-0.001457	-0.001823	-0.002188	-0.002553	-0.002918	-0.003283	-0.003648
AM/TDe =	-0.000579	0.000945	0.001163	0.001457	0.001823	0.002188	0.002553	0.002918	0.003283	0.003648
AM/TDe =	0.001048	-0.000945	-0.001163	-0.001457	-0.001823	-0.002188	-0.002553	-0.002918	-0.003283	-0.003648
AM/TDe =	-0.001048	0.000945	0.001163	0.001457	0.001823	0.002188	0.002553	0.002918	0.003283	0.003648
AM/TDe =	0.000710	-0.001123	-0.001457	-0.001823	-0.002188	-0.002553	-0.002918	-0.003283	-0.003648	-0.003990
AM/TDe =	-0.000710	0.001123	0.001457	0.001823	0.002188	0.002553	0.002918	0.003283	0.003648	0.003990
AM/TDe =	0.001131	-0.001304	-0.001658	-0.002026	-0.002395	-0.002764	-0.003133	-0.003502	-0.003871	-0.004240
AM/TDe =	-0.001131	0.001304	0.001658	0.002026	0.002395	0.002764	0.003133	0.003502	0.003871	0.004240
AM/TDe =	0.000389	-0.000630	-0.000948	-0.001269	-0.001592	-0.001915	-0.002238	-0.002561	-0.002884	-0.003207
AM/TDe =	-0.000389	0.000630	0.000948	0.001269	0.001592	0.001915	0.002238	0.002561	0.002884	0.003207
AM/TDe =	0.000357	-0.000419	-0.000489	-0.000550	-0.000620	-0.000690	-0.000760	-0.000830	-0.000900	-0.000970
AM/TDe =	-0.000357	0.000419	0.000489	0.000550	0.000620	0.000690	0.000760	0.000830	0.000900	0.000970
AM/TDe =	0.000186	-0.000029	-0.000424	-0.000419	-0.000419	-0.000419	-0.000419	-0.000419	-0.000419	-0.000419
AM/TDe =	-0.000186	0.000029	0.000424	0.000419	0.000419	0.000419	0.000419	0.000419	0.000419	0.000419
AM/TDe =	0.000409	-0.000204	-0.000229	-0.000145	-0.000110	-0.000092	-0.000074	-0.000056	-0.000038	-0.000020
AM/TDe =	-0.000409	0.000204	0.000229	0.000145	0.000110	0.000092	0.000074	0.000056	0.000038	0.000020
AM/TDe =	0.000127	-0.000363	-0.000239	-0.000165	-0.000109	-0.000076	-0.000050	-0.000024	-0.000008	0.000008
AM/TDe =	-0.000127	0.000363	0.000239	0.000165	0.000109	0.000076	0.000050	0.000024	0.000008	-0.000008
AM/TDe =	0.000230	-0.000386	-0.000194	-0.000384	-0.000465	-0.000519	-0.000537	-0.000530	-0.000523	-0.000516
AM/TDe =	-0.000230	0.000386	0.000194	0.000384	0.000465	0.000519	0.000537	0.000530	0.000523	0.000516
AM/TDe =	0.000297	-0.000366	-0.000441	-0.000494	-0.000523	-0.000537	-0.000530	-0.000523	-0.000516	-0.000509
AM/TDe =	-0.000297	0.000366	0.000441	0.000494	0.000523	0.000537	0.000530	0.000523	0.000516	0.000509
AM/TDe =	0.000102	-0.000987	-0.001238	-0.001116	-0.000978	-0.000840	-0.000715	-0.000590	-0.000465	-0.000340
AM/TDe =	-0.000102	0.000987	0.001238	0.001116	0.000978	0.000840	0.000715			

Configuration: 3C-8-3.9-12/8  
 Jet-Induced Pressure Increments  
 Run 293

Point	1	2	3	4	5	6	7	8
h/D <sub>e</sub>	17.56	11.70	8.78	5.84	4.68	3.50	2.31	1.73
Total Thrust =	136.70	136.56	136.57	136.40	136.40	136.43	136.41	136.40
NPR Front =	3.99	3.99	3.99	3.99	3.99	3.99	3.98	3.98
NPR Aft =	3.81	3.80	3.81	3.80	3.80	3.80	3.80	3.80
X-loc	Y-loc	ACP	ACP	ACP	ACP	ACP	ACP	ACP
5.50	-3.00	-0.000387	-0.000703	-0.000599	-0.002204	-0.003468	-0.004166	-0.005823
4.00	-3.00	-0.000387	-0.000703	-0.000599	-0.002204	-0.003468	-0.004166	-0.005823
2.50	-3.00	-0.000388	-0.001118	-0.001064	-0.023173	-0.027651	-0.032856	-0.038623
1.50	-3.00	-0.000949	-0.001112	-0.000767	-0.023163	-0.027651	-0.032856	-0.038623
0.00	-3.00	-0.000751	-0.000447	-0.000802	-0.023234	-0.027651	-0.032856	-0.038623
-1.50	-3.00	-0.000526	-0.000354	-0.000784	-0.023237	-0.027651	-0.032856	-0.038623
-2.50	-3.00	-0.000572	-0.000486	-0.000718	-0.023222	-0.027651	-0.032856	-0.038623
-4.00	-3.00	-0.000507	-0.000488	-0.000573	-0.023222	-0.027651	-0.032856	-0.038623
-5.50	-3.00	-0.000554	-0.000516	-0.000783	-0.023222	-0.027651	-0.032856	-0.038623
-7.50	-3.00	-0.000523	-0.000724	-0.000557	-0.023222	-0.027651	-0.032856	-0.038623
-9.50	-3.00	-0.000574	-0.000725	-0.000598	-0.023222	-0.027651	-0.032856	-0.038623
-11.50	-3.00	-0.000574	-0.000712	-0.000787	-0.023222	-0.027651	-0.032856	-0.038623
-13.50	-3.00	-0.000623	-0.000705	-0.000986	-0.023222	-0.027651	-0.032856	-0.038623
-15.50	-3.00	-0.000948	-0.001118	-0.001084	-0.023222	-0.027651	-0.032856	-0.038623
-17.50	-3.00	-0.001171	-0.000873	-0.000833	-0.023222	-0.027651	-0.032856	-0.038623
-19.50	-3.00	-0.001237	-0.000667	-0.000343	-0.019022	-0.027651	-0.032856	-0.038623
-21.50	-3.00	-0.000284	-0.000537	-0.000542	-0.010161	-0.010444	-0.005023	-0.008307
-23.50	-3.00	-0.000287	-0.000451	-0.000607	-0.014077	-0.004778	-0.010008	-0.005888
-25.50	-3.00	-0.000224	-0.000929	-0.000871	-0.021222	-0.005576	-0.010140	-0.008313
-27.50	-3.00	-0.000258	-0.000561	-0.000670	-0.000111	-0.000439	-0.002336	-0.005153
-29.50	-3.00	-0.000258	-0.000668	-0.001400	-0.000190	-0.000615	-0.003903	-0.008350
-31.50	-3.00	-0.000660	-0.000705	-0.000682	-0.000211	-0.000905	-0.005261	-0.008927
-33.50	-3.00	-0.000218	-0.000400	-0.000804	-0.000550	-0.000406	-0.001903	-0.004918
-35.50	-3.00	-0.000347	-0.000486	-0.000567	-0.000763	-0.003013	-0.007102	-0.011651
-37.50	-3.00	-0.000687	-0.000745	-0.000967	-0.000197	-0.000111	-0.003247	-0.007395
-39.50	-3.00	-0.000488	-0.000747	-0.000904	-0.000203	-0.000592	-0.003745	-0.007626
-41.50	-3.00	-0.000258	-0.000471	-0.000607	-0.003203	-0.006191	-0.010588	-0.016288
-43.50	-3.00	-0.000347	-0.000486	-0.000567	-0.000550	-0.000406	-0.001903	-0.004918
-45.50	-3.00	-0.000689	-0.000725	-0.000934	-0.000533	-0.000450	-0.003114	-0.007082
-47.50	-3.00	-0.000004	-0.001165	-0.000534	-0.001877	-0.002516	-0.002867	-0.003695
-49.50	-3.00	-0.001055	-0.001100	-0.001033	-0.002265	-0.002375	-0.003998	-0.003712
-51.50	-3.00	-0.001290	-0.001187	-0.001278	-0.002003	-0.002829	-0.003212	-0.003601
-53.50	-3.00	-0.001864	-0.001683	-0.001311	-0.002368	-0.003029	-0.003914	-0.004949
-55.50	-3.00	-0.001290	-0.001023	-0.000777	-0.001902	-0.001829	-0.001619	-0.000997
-57.50	-3.00	-0.000412	-0.000071	-0.000231	-0.002057	-0.003045	-0.004233	-0.006105
-59.50	-3.00	-0.000194	-0.000033	-0.000237	-0.002302	-0.003408	-0.005204	-0.009228
-61.50	-3.00	-0.000092	-0.000183	-0.000170	-0.001632	-0.002466	-0.003907	-0.007813
-63.50	-3.00	-0.000175	-0.000141	-0.000262	-0.001011	-0.000878	-0.000787	-0.002034
-65.50	-3.00	-0.000083	-0.000143	-0.000257	-0.001011	-0.000878	-0.000787	-0.002034
-67.50	-3.00	-0.000187	-0.000256	-0.000378	-0.000170	-0.000969	-0.004065	-0.021818
-69.50	-3.00	-0.000171	-0.000270	-0.000439	-0.001135	-0.004943	-0.016823	-0.025668
-71.50	-3.00	-0.000331	-0.000287	-0.000584	-0.002277	-0.006183	-0.015161	-0.027950
-73.50	-3.00	-0.000038	-0.000232	-0.000663	-0.002795	-0.008299	-0.019151	-0.009917
-75.50	-3.00	-0.000566	-0.000195	-0.000762	-0.000931	-0.001758	-0.002196	-0.007553
-77.50	-3.00	-0.000048	-0.000724	-0.000948	-0.000282	-0.000197	-0.003452	-0.006350
-79.50	-3.00	-0.000530	-0.000486	-0.000578	-0.000140	-0.000495	-0.002055	-0.003956
-81.50	-3.00	-0.000371	-0.000481	-0.000597	-0.000150	-0.000667	-0.007395	-0.008057
-83.50	-3.00	-0.000486	-0.000902	-0.000702	-0.001338	-0.000385	-0.003536	-0.007382
-85.50	-3.00	-0.000522	-0.000475	-0.001130	-0.000218	-0.000359	-0.003745	-0.008263
-87.50	-3.00	-0.000666	-0.000666	-0.001298	-0.000838	-0.002496	-0.007405	-0.012901

Force and Moment Summary  
 h/D<sub>e</sub> = 17.56    11.70    8.78  
 Balance AL/T = -0.008    -0.009    -0.010  
 Pressure AL/T = -0.012    -0.013    -0.015  
 Balance AM/TDe = -0.001    -0.002    -0.003  
 Pressure AM/TDe = -0.005    -0.005    -0.001

Configuration: 3C-8-3.9-12/8 Jet-Induced Pressure Increments Run 294

Point	1	2	3	4	5	6	7	8
Total Thrust =	17.55	11.70	8.77	5.84	4.68	3.50	2.32	1.74
NPR Front =	220.54	220.68	220.51	220.54	220.54	220.57	220.59	220.56
NPR Aft =	5.88	5.88	5.87	5.87	5.87	5.87	5.87	5.87
X-loc Y-loc	5.69	5.69	5.68	5.68	5.68	5.68	5.68	5.68
	ΔCP	ΔCP	ΔCP	ΔCP	ΔCP	ΔCP	ΔCP	ΔCP
5.50	-0.000274	-0.000425	-0.000808	-0.001924	-0.003748	-0.004217	-0.007032	-0.006487
4.50	-0.000274	-0.000425	-0.000808	-0.001924	-0.003748	-0.004217	-0.007032	-0.006487
3.50	-0.000944	-0.001141	-0.001096	-0.002055	-0.002527	-0.002527	-0.005462	-0.003772
2.50	-0.000319	-0.000403	-0.000507	-0.001915	-0.002814	-0.003816	-0.004180	-0.010283
1.50	-0.000500	-0.000522	-0.000375	-0.001481	-0.001088	-0.001330	-0.009852	-0.010264
0.00	-0.000545	-0.000266	-0.000545	-0.000263	-0.001387	-0.006620	-0.003497	-0.002540
-1.50	-0.000286	-0.000591	-0.000011	-0.000415	-0.001806	-0.006070	-0.003730	-0.007497
-2.50	-0.000590	-0.000837	-0.000130	-0.001152	-0.001174	-0.004508	-0.009000	-0.008728
-3.50	-0.000348	-0.000542	-0.000481	-0.000558	-0.000739	-0.002792	-0.006942	-0.007096
-4.75	-0.000434	-0.000584	-0.000550	-0.000313	-0.000426	-0.001837	-0.003963	-0.004749
-4.00	-0.000674	-0.000378	-0.001554	-0.001184	-0.001566	-0.011991	-0.017090	-0.015821
-2.50	-0.000716	-0.000454	-0.000552	-0.001069	-0.001327	-0.007588	-0.009357	-0.010761
-4.75	-0.000462	-0.000679	-0.000652	-0.001028	-0.000879	-0.006730	-0.011122	-0.012620
-5.50	-0.000591	-0.000341	-0.000471	-0.000766	-0.000879	-0.002527	-0.005462	-0.003772
-4.00	-0.000625	-0.000835	-0.002650	-0.003435	-0.004781	-0.011874	-0.028266	-0.027574
-5.50	-0.000944	-0.001141	-0.000471	-0.000766	-0.000879	-0.002527	-0.005462	-0.003772
-4.75	-0.000625	-0.000835	-0.002650	-0.003435	-0.004781	-0.011874	-0.028266	-0.027574
-1.50	-0.000625	-0.000835	-0.002650	-0.003435	-0.004781	-0.011874	-0.028266	-0.027574
-2.50	-0.000944	-0.001141	-0.000471	-0.000766	-0.000879	-0.002527	-0.005462	-0.003772
-1.50	-0.000315	-0.000134	-0.000707	-0.001811	-0.003621	-0.004366	-0.002891	-0.017208
-1.50	-0.000207	-0.000134	-0.000281	-0.000823	-0.003004	-0.003379	-0.015075	-0.020000
-1.50	-0.000325	-0.000237	-0.000849	-0.001687	-0.003721	-0.011676	-0.015379	-0.020000
-1.50	-0.000442	-0.000460	-0.000510	-0.001934	-0.003721	-0.011676	-0.015379	-0.020000
-2.50	-0.000457	-0.000500	-0.000680	-0.001194	-0.003311	-0.001942	-0.004830	-0.005744
-1.50	-0.000972	-0.000859	-0.000312	-0.000277	-0.002581	-0.010029	-0.013987	-0.012603
-4.75	-0.000691	-0.000925	-0.000055	-0.000655	-0.002963	-0.004412	-0.008027	-0.008316
-1.00	-0.000161	-0.000311	-0.000132	-0.000191	-0.001028	-0.001205	-0.002258	-0.002358
-2.50	-0.000426	-0.000479	-0.000221	-0.000301	-0.001358	-0.001975	-0.004025	-0.004574
-1.00	-0.000426	-0.000479	-0.000221	-0.000301	-0.001358	-0.001975	-0.004025	-0.004574
-0.98	-0.000972	-0.000859	-0.000312	-0.000277	-0.002581	-0.010029	-0.013987	-0.012603
-4.00	-0.000808	-0.000589	-0.000242	-0.000210	-0.000489	-0.002765	-0.005982	-0.005982
-4.75	-0.000646	-0.000731	-0.000534	-0.001569	-0.004126	-0.006627	-0.007952	-0.007632
-2.50	-0.000631	-0.000731	-0.000534	-0.001569	-0.004126	-0.006627	-0.007952	-0.007632
-0.50	-0.000426	-0.000479	-0.000221	-0.000301	-0.001358	-0.001975	-0.004025	-0.004574
-4.00	-0.000617	-0.000716	-0.000642	-0.001122	-0.000308	-0.001843	-0.006587	-0.005788
-4.75	-0.000617	-0.000716	-0.000642	-0.001122	-0.000308	-0.001843	-0.006587	-0.005788
5.85	0.00	-0.000695	-0.000792	-0.001025	-0.001731	-0.002249	-0.005580	-0.003368
5.50	0.00	-0.000800	-0.001025	-0.000960	-0.001731	-0.002249	-0.005580	-0.003368
5.15	0.00	-0.000742	-0.000944	-0.001219	-0.002009	-0.002413	-0.003238	-0.005471
4.80	0.00	-0.001170	-0.001621	-0.001635	-0.002289	-0.002974	-0.003552	-0.007957
3.20	0.00	-0.000771	-0.000870	-0.000720	-0.001643	-0.002552	-0.003252	-0.006138
2.85	0.00	-0.000483	-0.000438	-0.001001	-0.001714	-0.002658	-0.004558	-0.003266
2.50	0.00	-0.000243	-0.000395	-0.000750	-0.001864	-0.002561	-0.004350	-0.006119
2.15	0.00	-0.000217	-0.000148	-0.000902	-0.001994	-0.002748	-0.005080	-0.008140
1.50	0.00	-0.000087	-0.000140	-0.000882	-0.001664	-0.002380	-0.002716	-0.004195
0.75	0.00	-0.000041	-0.000042	-0.000424	-0.001197	-0.001174	-0.000392	-0.002790
0.00	0.00	-0.000101	-0.000068	-0.000875	-0.000410	-0.000738	-0.004365	-0.024526
-0.75	0.00	-0.000109	-0.000084	-0.000103	-0.000382	-0.001723	-0.010333	-0.024526
-1.50	0.00	-0.000064	-0.000129	-0.000186	-0.000303	-0.003633	-0.013246	-0.016178
-2.50	0.00	-0.000095	-0.000258	-0.000684	-0.001465	-0.003776	-0.008242	-0.005471
-4.00	0.00	-0.000592	-0.000550	-0.000921	-0.001336	-0.000608	-0.001805	-0.002368
-4.75	0.00	-0.000765	-0.000585	-0.000451	-0.001092	-0.000172	-0.003235	-0.005175
-5.50	0.00	-0.000470	-0.000623	-0.000777	-0.000407	-0.000177	-0.003235	-0.005175
-4.00	0.32	-0.000487	-0.000671	-0.000518	-0.000660	-0.000500	-0.002325	-0.006376
-4.00	0.45	-0.000840	-0.000577	-0.000517	-0.000550	-0.000114	-0.002351	-0.006643
-4.00	0.98	-0.000634	-0.000609	-0.000426	-0.001113	-0.004472	-0.008120	-0.005971
-4.00	1.30	-0.000865	-0.000731	-0.000026	-0.000697	-0.003449	-0.008586	-0.012805

Force and Moment Summary

Balance h/D <sub>e</sub> =	17.55	11.70	8.77	5.84	4.68	3.50	2.32	1.74
Balance AL/T =	-0.007	-0.008	-0.008	-0.016	-0.017	-0.011	-0.030	-0.035
Balance AL/T =	-0.009	-0.011	-0.010	-0.019	-0.018	-0.011	-0.049	-0.060
Balance AM/TDe =	0.002	0.002	-0.005	-0.018	-0.031	-0.048	-0.046	-0.063
Balance ΔM/TDe =	-0.002	-0.003	-0.021	-0.044	-0.061	-0.105	-0.119	-0.118

0-4



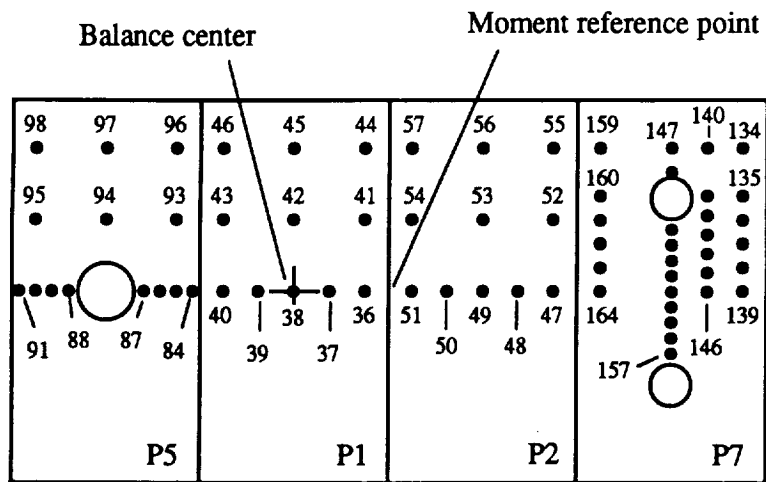

Figure 83. Configuration 3C\_12\_3.9\_16/8;  $D_e = 1.709$  in.,  $A_{jet} = 2.29$  in.<sup>2</sup>.

Pressure Orifice Locations and Weighting Factors

Conf. # 3C-12-3.9-16/8

Distance from balance center to moment reference point,  $X_0 = 0$

Orif. #	Mom. arm	Sta. y	$\Delta$ .Area	Sta. x
134	-7.56	-3	3.063	-7.5
135	-7.56	-2	0.875	-7.5
136	-7.56	-1.5	0.875	-7.5
137	-7.56	-1	0.875	-7.5
138	-7.56	-0.5	0.875	-7.5
139	-7.56	0	0.438	-7.5
140	-6.75	-3	2.625	-6.75
141	-6.75	-2	0.534	-6.75
142	-6.75	-1.6	0.575	-6.75
143	-6.75	-1.2	0.6	-6.75
144	-6.75	-0.8	0.6	-6.75
145	-6.75	-0.4	0.6	-6.75
146	-6.75	0	0.3	-6.75
147	-6	-3	2.006	-6
148	-6	-2.5	0.54	-6
149	-6	-1.3	0.54	-6
150	-6	-0.975	0.488	-6
151	-6	-0.65	0.488	-6
152	-6	-0.325	0.488	-6
153	-6	0	0.244	-6
154	-6	0.325	0	-6
155	-6	0.65	0	-6
156	-6	0.975	0	-6
157	-6	1.3	0	-6
159	-4.81	-3	5.688	-4.5
160	-4.837	-2	1.559	-4.5
161	-4.837	-1.5	1.6	-4.5
162	-4.837	-1	1.625	-4.5
163	-4.837	-0.5	1.625	-4.5
164	-4.5	0	0.438	-4.5
47	-3.5	0	1.313	-3.5
48	-2.75	0	1.125	-2.75
49	-2	0	1.125	-2
50	-1.25	0	1.125	-1.25
51	-0.5	0	1.313	-0.5
52	-3.5	-1.5	3.75	-3.5
53	-2	-1.5	4.5	-2
54	-0.5	-1.5	3.75	-0.5
55	-3.5	-3	4.375	-3.5
56	-2	-3	5.25	-2
57	-0.5	-3	4.375	-0.5
36	0.5	0	1.313	0.5
37	1.25	0	1.125	1.25
38	2	0	1.125	2
39	2.75	0	1.125	2.75
40	3.5	0	1.313	3.5

Conf. # 3C\_12\_3.9\_16/8, continued

Orif. #	Mom. arm	Sta. y	$\Delta$ .Area	Sta. x
41	0.5	-1.5	3.75	0.5
42	2	-1.5	4.5	2
43	3.5	-1.5	3.75	3.5
44	0.5	-3	4.375	0.5
45	2	-3	5.25	2
46	3.5	-3	4.375	3.5
84	4.15	0	0.634	4.15
85	4.5	0	0.683	4.5
86	4.85	0	0.683	4.85
87	5.2	0	0.619	5.2
88	6.8	0	0.619	6.8
89	7.15	0	0.683	7.15
90	7.5	0	0.683	7.5
91	7.85	0	0.634	7.85
93	4.5	-1.5	3.19	4.5
94	6	-1.5	5.062	6
95	7.5	-1.5	3.19	7.5
96	4.5	-3	4.375	4.5
97	6	-3	5.25	6
98	7.5	-3	4.375	7.5

Configuration: 3C-12-3.9-16/8 Jet-Induced Pressure Increments Run 295

Point	1	2	3	4	5	6	7
h/D <sub>e</sub>	33.73	1.16	1.76	2.35	3.52	5.85	8.79
Total Thrust =	51.50	51.35	51.26	51.28	51.31	51.27	51.23
NPR Front =	2.01	2.01	2.01	2.01	2.01	2.01	2.01
NPR Aft =	1.92	1.92	1.91	1.92	1.92	1.91	1.91
X-loc	Y-loc	ACP	ACP	ACP	ACP	ACP	ACP
h/D <sub>e</sub>	0.00	0.00	0.00	0.00	0.00	0.00	0.00
Total Thrust =	-6.75	0.00	0.00	0.00	0.00	0.00	0.00
NPR Front =	-7.50	0.00	0.00	0.00	0.00	0.00	0.00
NPR Aft =	-8.00	0.00	0.00	0.00	0.00	0.00	0.00
X-loc	Y-loc	ACP	ACP	ACP	ACP	ACP	ACP
h/D <sub>e</sub>	33.73	1.16	1.76	2.35	3.52	5.85	8.79
Total Thrust =	51.50	51.35	51.26	51.28	51.31	51.27	51.23
NPR Front =	2.01	2.01	2.01	2.01	2.01	2.01	2.01
NPR Aft =	1.92	1.92	1.91	1.92	1.92	1.91	1.91
X-loc	Y-loc	ACP	ACP	ACP	ACP	ACP	ACP
h/D <sub>e</sub>	0.00	0.00	0.00	0.00	0.00	0.00	0.00
Total Thrust =	-6.75	0.00	0.00	0.00	0.00	0.00	0.00
NPR Front =	-7.50	0.00	0.00	0.00	0.00	0.00	0.00
NPR Aft =	-8.00	0.00	0.00	0.00	0.00	0.00	0.00
X-loc	Y-loc	ACP	ACP	ACP	ACP	ACP	ACP

Force and Moment Summary	1	2	3	4	5	6	7
Balance	33.73	1.16	1.76	2.35	3.52	5.85	8.79
Pressure	-0.014	-0.151	-0.118	-0.076	-0.042	-0.008	-0.003
Pressure	0.041	0.155	0.115	0.079	0.048	0.018	0.011
Pressure	0.007	0.023	0.028	0.034	0.024	0.006	0.039
Pressure	-0.007	-0.065	-0.095	-0.085	-0.076	-0.070	-0.024





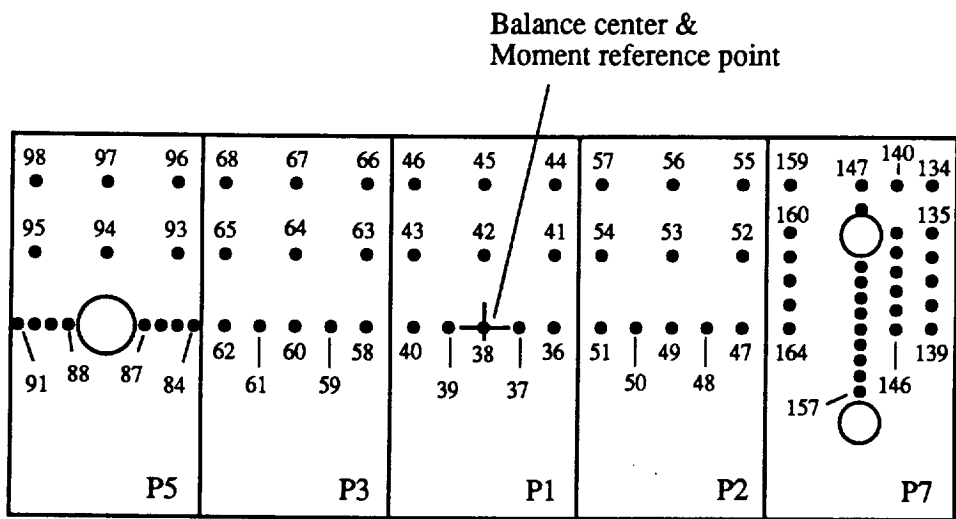

Figure 84. Configuration 3C\_16\_3.9\_20/8;  $D_e = 1.709 \text{ in.}$ ,  $A_{jet} = 2.29 \text{ in.}^2$ .

Pressure Orifice Locations and Weighting Factors

Conf. # 3C\_16\_3.9\_20/8

Distance from balance center to moment reference point,  $X_0 = 0$

Orif. #	Mom. arm	Sta. y	$\Delta$ .Area	Sta. x
134	-9.56	-3	3.063	-9.5
135	-9.56	-2	0.875	-9.5
136	-9.56	-1.5	0.875	-9.5
137	-9.56	-1	0.875	-9.5
138	-9.56	-0.5	0.875	-9.5
139	-9.56	0	0.438	-9.5
140	-8.75	-3	2.625	-8.75
141	-8.75	-2	0.534	-8.75
142	-8.75	-1.6	0.575	-8.75
143	-8.75	-1.2	0.6	-8.75
144	-8.75	-0.8	0.6	-8.75
145	-8.75	-0.4	0.6	-8.75
146	-8.75	0	0.3	-8.75
147	-8	-3	2.006	-8
148	-8	-2.5	0.54	-8
149	-8	-1.3	0.54	-8
150	-8	-0.975	0.488	-8
151	-8	-0.65	0.488	-8
152	-8	-0.325	0.488	-8
153	-8	0	0.244	-8
154	-8	0.325	0	-8
155	-8	0.65	0	-8
156	-8	0.975	0	-8
157	-8	1.3	0	-8
159	-6.81	-3	5.688	-6.5
160	-6.837	-2	1.559	-6.5
161	-6.837	-1.5	1.6	-6.5
162	-6.837	-1	1.625	-6.5
163	-6.837	-0.5	1.625	-6.5
164	-6.5	0	0.438	-6.5
47	-5.5	0	1.313	-5.5
48	-4.75	0	1.125	-4.75
49	-4	0	1.125	-4
50	-3.25	0	1.125	-3.25
51	-2.5	0	1.313	-2.5
52	-5.5	-1.5	3.75	-5.5
53	-4	-1.5	4.5	-4
54	-2.5	-1.5	3.75	-2.5
55	-5.5	-3	4.375	-5.5
56	-4	-3	5.25	-4
57	-2.5	-3	4.375	-2.5
36	-1.5	0	1.313	-1.5
37	-0.75	0	1.125	-0.75
38	0	0	1.125	0
39	0.75	0	1.125	0.75
40	1.5	0	1.313	1.5



Conf. # 3C\_16\_3.9\_20/8, continued

Orif. #	Mom. arm	Sta. y	Δ.Area	Sta. x
41	-1.5	-1.5	3.75	-1.5
42	0	-1.5	4.5	0
43	1.5	-1.5	3.75	1.5
44	-1.5	-3	4.375	-1.5
45	0	-3	5.25	0
46	1.5	-3	4.375	1.5
58	2.5	0	1.313	2.5
59	3.25	0	1.125	3.25
60	4	0	1.125	4
61	4.75	0	1.125	4.75
62	5.5	0	1.313	5.5
63	2.5	-1.5	3.75	2.5
64	4	-1.5	4.5	4
65	5.5	-1.5	3.75	5.5
66	2.5	-3	4.375	2.5
67	4	-3	5.25	4
68	5.5	-3	4.375	5.5
84	6.15	0	0.634	6.15
85	6.5	0	0.683	6.5
86	6.85	0	0.683	6.85
87	7.2	0	0.619	7.2
88	8.8	0	0.619	8.8
89	9.15	0	0.683	9.15
90	9.5	0	0.683	9.5
91	9.85	0	0.634	9.85
93	6.5	-1.5	3.19	6.5
94	8	-1.5	5.062	8
95	9.5	-1.5	3.19	9.5
96	6.5	-3	4.375	6.5
97	8	-3	5.25	8
98	9.5	-3	4.375	9.5



Point	1	2	3	4	5	6	7	8	9	10
h/D <sub>e</sub> =	33.71	17.58	11.71	8.79	5.86	4.67	3.50	2.32	1.74	1.14
Total Thrust =	52.28	52.09	52.13	52.08	52.08	52.07	52.09	52.03	52.02	51.96
NPR Front =	2.04	2.04	2.04	2.04	2.04	2.04	2.04	2.04	2.04	2.04
NPR Aft =	1.94	1.93	1.94	1.94	1.94	1.94	1.94	1.94	1.93	1.93
X-loc	ACP	ACP	ACP	ACP	ACP	ACP	ACP	ACP	ACP	ACP
-4.75	0.00	-0.000332	-0.000661	-0.001183	-0.001764	-0.002749	-0.003046	-0.000754	0.002206	0.009360
-5.50	0.00	-0.000312	-0.000661	-0.001203	-0.002400	-0.003123	-0.003678	-0.001967	0.001437	0.007765
-6.50	0.00	-0.000270	-0.000512	-0.000857	-0.001696	-0.002892	-0.003403	-0.001699	0.005569	0.017621
-8.00	0.00	-0.000770	-0.000828	-0.001334	-0.001652	-0.002460	-0.002294	-0.002136	0.007851	0.034987
-8.75	0.00	-0.000665	-0.000803	-0.000983	-0.001192	-0.000955	-0.001260	-0.001859	0.007007	0.024089
-9.50	0.00	-0.000840	-0.000994	-0.001229	-0.000823	-0.000788	-0.000889	-0.000543	0.001563	0.001545
-8.00	0.32	-0.000590	-0.000864	-0.001229	-0.001446	-0.002831	-0.002079	-0.002148	-0.002231	0.005358
-8.00	0.65	-0.000920	-0.000864	-0.001188	-0.001442	-0.002577	-0.002305	-0.002023	-0.002980	0.000186
-8.00	0.98	-0.000795	-0.001094	-0.001264	-0.002234	-0.002947	-0.002947	-0.003644	-0.004765	-0.012558
-8.00	1.30	-0.001201	-0.001335	-0.001424	-0.002781	-0.005331	-0.004750	-0.003132	-0.003412	-0.001377

Force and Moment Summary

h/D <sub>e</sub> =	33.71	17.58	11.71	8.79	5.86	4.67	3.50	2.32	1.74	1.14
Balance AL/T =	-0.015	-0.018	-0.022	-0.019	-0.019	-0.033	-0.047	-0.080	-0.110	-0.174
Pressure AL/T =	-0.003	-0.000	0.005	0.007	-0.043	-0.062	-0.055	-0.079	-0.118	-0.193
Balance ΔM/7D <sub>e</sub> =	-0.001	-0.004	0.006	-0.005	-0.056	-0.072	-0.075	-0.104	-0.097	-0.099
Pressure ΔM/7D <sub>e</sub> =	-0.001	-0.004	0.006	-0.005	-0.056	-0.072	-0.075	-0.104	-0.097	-0.114



Point	1	2	3	4	5	6	7	8	9
h/Da =	17.54	11.70	8.77	5.85	4.66	3.48	2.31	1.73	1.15
Total Thrust =	136.39	136.12	136.13	135.99	135.94	135.98	135.98	135.97	135.85
NPR Front =	4.00	4.00	4.00	3.99	3.99	3.99	3.99	3.99	3.99
NPR Aft =	3.83	3.82	3.82	3.81	3.81	3.81	3.81	3.81	3.81
X-loc	ACP	ACP	ACP	ACP	ACP	ACP	ACP	ACP	ACP
	-4.75	0.00	-0.000363	-0.000474	-0.000920	-0.001051	-0.001827	-0.001121	0.008330
	-5.50	0.00	-0.000255	-0.000383	-0.000905	-0.001624	-0.002036	-0.002460	0.011570
	-6.50	0.00	-0.000360	-0.000419	-0.001143	-0.001855	-0.002581	-0.002073	0.028480
	-8.00	0.00	-0.000293	-0.000474	-0.001385	-0.001434	-0.001736	-0.001554	0.040347
	-8.75	0.00	-0.000466	-0.000703	-0.001164	-0.000669	-0.001312	-0.001256	0.029891
	-9.50	0.00	-0.000324	-0.000557	-0.001162	-0.000321	-0.000511	-0.002029	0.005889
	-8.00	0.32	-0.000349	-0.000455	-0.001221	-0.001325	-0.001789	-0.001882	0.001600
	-8.00	0.65	-0.000629	-0.000784	-0.001177	-0.001701	-0.001939	-0.002010	0.005237
	-8.00	0.98	-0.000629	-0.000693	-0.001425	-0.001177	-0.002338	-0.003132	0.001129
	-8.00	1.30	-0.001605	-0.000931	-0.001677	-0.006026	-0.002894	-0.003547	-0.002363
									0.005519
									0.008842

Force and Moment Summary

Balance h/Da =	17.54	11.70	8.77	5.85	4.66	3.48	2.31	1.73	1.15
Pressure AL/T =	-0.012	-0.015	-0.028	-0.010	-0.022	-0.035	-0.042	-0.082	-0.145
Balance AM/TDe =	-0.017	-0.012	0.014	-0.019	-0.029	-0.034	-0.059	-0.085	-0.148
Pressure AN/TDe =	-0.006	-0.003	0.013	-0.057	-0.048	-0.074	-0.063	-0.057	-0.075
Balance AM/TDe =	-0.006	-0.003	0.013	-0.057	-0.075	-0.091	-0.093	-0.083	-0.102





# REPORT DOCUMENTATION PAGE

Form Approved  
OMB No. 0704-0188

Public reporting burden for this collection of information is estimated to average 1 hour per response, including the time for reviewing instructions, searching existing data sources, gathering and maintaining the data needed, and completing and reviewing the collection of information. Send comments regarding this burden estimate or any other aspect of this collection of information, including suggestions for reducing this burden, to Washington Headquarters Services, Directorate for Information Operations and Reports, 1215 Jefferson Davis Highway, Suite 1204, Arlington, VA 22202-4302, and to the Office of Management and Budget, Paperwork Reduction Project (0704-0188), Washington, DC 20503.

1. AGENCY USE ONLY (Leave blank)	2. REPORT DATE March 1993	3. REPORT TYPE AND DATES COVERED Technical Memorandum	
4. TITLE AND SUBTITLE  Jet-Induced Ground Effects on a Parametric Flat-Plate Model in Hover		5. FUNDING NUMBERS  505-68-32	
6. AUTHOR(S) Douglas A. Wardwell, Craig E. Hange, Richard E. Kuhn* and Vearl R. Stewart*		8. PERFORMING ORGANIZATION REPORT NUMBER  A-93040	
7. PERFORMING ORGANIZATION NAME(S) AND ADDRESS(ES)  Ames Research Center Moffett Field, CA 94035-1000		9. SPONSORING/MONITORING AGENCY REPORT NUMBER  NASA TM-104001	
9. SPONSORING/MONITORING AGENCY NAME(S) AND ADDRESS(ES) National Aeronautics and Space Administration Washington, DC 20546-0001 U.S. Air Force, Flight Dynamics Laboratory, Wright-Patterson Air Force Base, OH William B. Blake, Contract Technical Monitor		10. SPONSORING/MONITORING AGENCY REPORT NUMBER  NASA TM-104001	
11. SUPPLEMENTARY NOTES  Point of Contact: Douglas A. Wardwell, Ames Research Center, MS 237-3, Moffett Field, CA 94035-1000; (415) 604-6566 *KSA Technology, Columbus, OH			
12a. DISTRIBUTION/AVAILABILITY STATEMENT  Unclassified — Unlimited Subject Category 02		12b. DISTRIBUTION CODE	
13. ABSTRACT (Maximum 200 words)  The jet-induced forces generated on short takeoff and vertical landing (STOVL) aircraft when in close proximity to the ground can have a significant effect on aircraft performance. Therefore, accurate predictions of these aerodynamic characteristics are highly desirable. Empirical procedures for estimating jet-induced forces during the vertical/short takeoff and landing (V/STOL) portions of the flight envelope are currently limited in accuracy. The jet-induced force data presented in this report significantly add to the current STOVL configurations data base. Further development of empirical prediction methods for jet-induced forces, to provide more configuration diversity and improved overall accuracy, depends on the viability of this STOVL data base. The data base may also be used to validate computational fluid dynamics (CFD) analysis codes.  This report presents the hover data obtained at the NASA Ames Jet Calibration and Hover Test (JCAHT) facility for a parametric flat-plate model. The model tested was designed to allow variations in the planform aspect ratio, number of jets, nozzle shape, and jet location. There were 31 different planform/nozzle configurations tested. Each configuration had numerous pressure taps installed to measure the pressures on the undersurface of the model. All pressure data, along with the balance jet-induced lift and pitching-moment increments, are tabulated. For selected runs, pressure data will be presented in the form of contour plots that show lines of constant pressure coefficient on the model undersurface. Nozzle-thrust calibrations and jet-flow-pressure survey information are also provided.			
14. SUBJECT TERMS Jet-induced forces, STOVL, Jet-induced prediction methods, Planform aspect ratio, Nozzle shape, Pressure data, Jet-flow survey		15. NUMBER OF PAGES 308	16. PRICE CODE A14
17. SECURITY CLASSIFICATION OF REPORT Unclassified	18. SECURITY CLASSIFICATION OF THIS PAGE Unclassified	19. SECURITY CLASSIFICATION OF ABSTRACT	20. LIMITATION OF ABSTRACT