

Automation & Robotics Human Performance

*IN 54-CR
DATE
OVERRIDE*

Special Assessment Agent Annual Report FY 89

January 17, 1990

Robert W. Mah, Ph.D
Special Assessment Agent
Automation & Robotics / Human Performance

Advanced Missions Technology Branch
Information Sciences Division

NASA-Ames Research Center

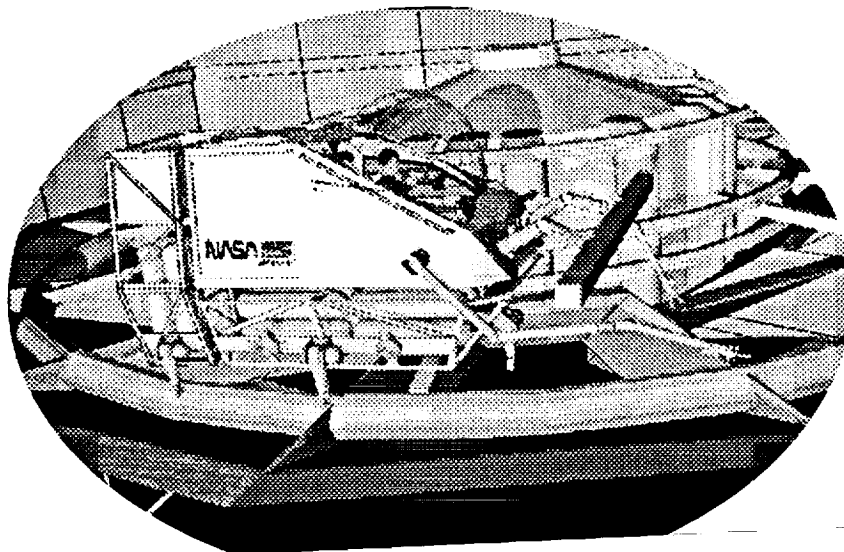

(NASA-CR-193049) AUTOMATION AND
ROBOTICS HUMAN PERFORMANCE Annual
Report, FY 1989 (NASA) 135 p

N93-26153

Unclas

G3/54 0163067

TABLE OF CONTENTS

INTRODUCTION	1
1.0 CASE STUDIES TECHNOLOGY ASSESSMENT	3
1.1 AUTOMATION and ROBOTICS	3
1.1.1 Barriers	4
1.1.2 Critical Concepts and Results	5
1.1.2.1 Critical Concepts Areas	5
1.1.2.2 Development Results	5
1.1.3 High Leverage Areas and Results	6
1.1.3.1 High Leverage Areas	6
1.1.3.2 Development Results	7
1.2 GENERAL AUTOMATION & ROBOTIC ISSUES	9
1.2.1 Automation & Robotic Definitions	9
1.2.2 Functions	9
1.2.2.1 EVA Functions	10
1.2.2.2 Teleoperated Functions	10
1.2.3 Design Guidelines	11
1.3 HUMAN PERFORMANCE	17
1.3.1 Introduction	17
1.3.2 Techniques to Determine Solar System Exploration Crew Size	18
1.3.2.1 Proposed Techniques to Determine Crew Size	18
1.3.2.1.1 Functional Requirements Analysis	19
1.3.2.1.2 Task Requirements Analysis	23
1.3.2.2 Example Application of Proposed Techniques	28
1.3.2.2.1 Functional Requirements Analysis of Mars Mission	29
1.3.2.2.2 Task Requirements Analysis of Mars Mission	31
1.3.2.2.3 Combining the Results of Example	41
1.3.2.3 Human Factors Design Guidelines	42
1.3.3 Computer Tools	42
1.3.3.1 Introduction to Computer Tool Survey	42
1.3.3.2 Survey Results	42
1.3.4 Results and Conclusions	43
1.3.4.1 Crew Size Selections Techniques	43
1.3.4.2 Example Mars Mission Analysis Results and Conclusions	44
1.3.4.3 Computer Tools Survey Results and Conclusions	45
1.3.4.4 Design Guidelines	46

2.0	IN-SPACE OPERATIONS.....	47
2.1	DEPLOYABLE AEROBRAKE.....	48
2.2	IN-SPACE ASSEMBLY.....	49
2.2.1	Intelligent Maneuvering Vehicle.....	49
2.2.2	Spacecraft Assembly.....	51
2.2.2.1	In-Hanger Spacecraft Assembly.....	52
2.2.2.2	Free Flying Spaceraft Assembly.....	53
2.2.3	Assembly Techniques.....	54
2.2.4	Assembly Operations Analysis.....	55
2.3	HANDLING LARGE STRUCTURES.....	56
2.4	AUTOMATED RENDEZVOUS & DOCKING.....	56
2.5	PROPELLANT TRANSFER & HANDLING.....	60
2.5.1	Propellant Transfer.....	60
2.5.2	Helical Tanker.....	61
2.6	ENHANCED FTS.....	61
2.6.1	Requirements.....	63
2.6.2	Transportation Vehicle Assembly.....	64
2.6.3	Rendezvous and Docking.....	64
2.6.4	FTS Conclusions.....	65
2.7	ON-ORBIT MAINTENANCE AND REPAIR.....	65
2.8	ADVANCED ENGINEERING SOFTWARE.....	66
2.8.1	Requirements.....	66
2.8.2	In-Space Assembly.....	67
2.8.3	Automated Docking with Robotic Arms.....	70
2.8.4	Propellant Transfer in zero G.....	71
2.8.5	Mars Orbiting Vehicle AES.....	71
2.9	DEPLOYMENT/CONTROL, ARTIFICIAL GRAVITY.....	74
2.10	CONCLUSIONS.....	76

3.0	PLANETARY SURFACE OPERATIONS.....	77
3.1	PLANNING	77
3.1.1	Functions.....	77
3.1.2	Outpost Elements	78
3.1.2.1	Primary Elements.....	78
3.1.2.2	Mobile Robots.....	78
3.1.2.3	Utilities.....	80
3.1.2.4	Siteworks.....	80
3.2	LANDING SITE.....	80
3.2.1	Initial Preparation	80
3.2.2	Automated Landing Operations.....	80
3.3	PROPELLENT PRODUCTION.....	83
3.3.1	Surface Mining.....	84
3.3.1.1	Digging and Transport Vehicles.....	84
3.3.1.2	Intelligent Communicating Carts.....	85
3.3.2	Processing Facility	85
3.4	PLANETARY SURFACE HABITAT	86
3.4.1	Domes	86
3.4.2	Modules.....	88
3.4.3	Shielding.....	88
3.5	RELIABILITY.....	89
3.6	ENHANCED FTS, MINING/CONSTRUCTION.....	90
3.7	ADVANCED SOFTWARE.....	91

5.0	SIMULATIONS & VALIDATIONS	94
5.1	TRADEOFF METHODOLOGIES.....	94
5.1.1	THURIS Program.....	94
5.1.2	Econ ADSS	95
5.2	GRAPHICS/VIDEO DEMONSTRATION.....	96
5.3	FTS METRIC TOOL.....	98
5.3.1	Metric Development.....	98
5.3.2	Metric Formulation.....	99
5.3.3	General Findings.....	100
5.3.4	Specific Findings.....	101
5.3.5	The Applicability of FTS to Advanced Mission Activities.....	101
5.3.6	Assembly of Vehicle Hangar.....	102
5.4	INTELLIGENT COMMUNICATING SYSTEMS.....	104
5.4.1	Advanced Engineering Software	104
5.4.1.1	Background.....	105
5.4.1.2	Barriers to Mission Objectives	107
5.4.1.3	Implementation Issues	108
5.4.1.4	Conclusions	109
5.4.2	Finite-State-Machine Architecture.....	110
5.4.2.1	States	111
5.4.2.2	Messages	111
5.5	PATH PLANNING.....	112
5.5.1	Literature Review.....	112
5.5.1.1	Two-Dimensional Environment.....	112
5.5.1.2	Three-Dimensional Environments.....	114
5.5.1.3	Manipulators Planning for Robot Arms	114
5.5.1.4	Multi-robot Systems.....	115
5.5.1.5	Sensing.....	115
5.5.1.6	Uncertainty	116
5.5.1.7	Reactive	116
5.5.1.8	Semi-reactive.....	117
5.5.2	Space Construction Problem Classification.....	117
5.5.2.1	Knowledge of the Environment	117
5.5.2.2	Resources.....	118
5.5.2.3	Initial and Final Conditions.....	119
5.5.2.4	Degrees of Freedom.....	119
5.5.2.5	Dynamic Environments.....	119
5.5.2.6	Free Flying vs. Mounted.....	120
5.5.3	Classes of Space Problems.....	120
5.5.4	Suggestions and Implications.....	122
5.5.5	Synergy.....	124
5.6	FEASIBILITY DEMONSTRATIONS	125
	REFERENCES	126

LIST OF FIGURES

Figure 1-1.	Special Assessments.....	3
Figure 1-2.	Process for Functional and Task Requirements Analyses.....	17
Figure 1-3.	Solar System Exploration Functions.....	22
Figure 1-4.	Example Worksheet for Functional Requirements Analysis.....	23
Figure 1-5.	Example Task Requirements Analysis Worksheet.....	25
Figure 1-6.	Example THURIS Worksheet.....	26
Figure 1-7.	THURIS Automation Levels.....	27
Figure 1-8.	Example THURIS Cost Optimization Curve.....	27
Figure 1-9.	Example Task Time Line Worksheet.....	28
Figure 1-10.	Function Analysis Crew Size Summary Data.....	30
Figure 1-11.	Petal Aerobrake Concept Stowed for Earth to LEO.....	32
Figure 1-12.	Aerobrake Deploying at LEO.....	33
Figure 1-13.	Aerobrake Deployed for LEO to Mars.....	34
Figure 1-14.	Space Station Freedom Food Supplement System.....	36
Figure 1-15.	Cross Section of Salad Machine.....	37
Figure 1-16.	Salad Machine Block Diagram.....	38
Figure 1-17.	Geodesic Dome Structure Design.....	40
Figure 2-1.	Deployable Symmetrical Aerobrake.....	48
Figure 2-2.	Intelligent Maneuvering Vehicle.....	49
Figure 2-3.	IMV Modules.....	50
Figure 2-4.	IMV Manipulator Arm.....	51
Figure 2-5.	Spacecraft Assembly Sequence.....	52
Figure 2-6.	Assembly of the Aerobrake at Space Station.....	53
Figure 2-7.	Joining Methods.....	54
Figure 2-8.	Automated Rendezvous and Docking Mechanism.....	57
Figure 2-9.	Sensors and Robotic Arms for Rendezvous.....	58
Figure 2-10.	Final Docking with Energy Dissipation and Storage.....	58
Figure 2-11.	Space Sub Attaching Docking Mechanism to Tank.....	59
Figure 2-12.	Voids Development in Pressurized Tank.....	60
Figure 2-13.	Tank with Internal Archimedes Screw.....	61
Figure 2-14.	Helical Tanker Refueling Tanks Aboard Spacecraft.....	62
Table I.	Automation & Robotics Capabilities.....	69
Figure 2-15.	In-Space Assembly AES Architecture.....	70
Figure 2-16.	MOV On-Board AES Architecture.....	72
Figure 2-17.	Vehicle Control and FDIR Architecture.....	73
Figure 2-18.	MOV Data Management System Hardware Architecture.....	74
Figure 2-19.	Manned Spacecraft Deploys Artificial Gravity Modules.....	75

Figure 3-1.	Planetary Modules for the IMV.....	79
Figure 3-2.	Wide-field Landing System.....	81
Figure 3-3.	Near-field Landing System Used for Final Descent.....	82
Figure 3-4.	Unloading Space Station Modules.....	83
Figure 3-5.	Deployable Domed Habitat.....	86
Figure 3-6.	Design of Domed Habitat.....	87
Figure 3-7.	IMV Constructing Module Habitat.....	88
Figure 3-8.	Radiation Shield for Habitat.....	89
Figure 3-9.	Surface Tasks.....	92
Figure 3-10.	Planetary Surface Operations Software.....	92
Figure 3-11.	High Level View of Surface System.....	93
Figure 5-1.	IMV in Orbit.....	96
Figure 5-2.	IMV Assembling Aerobrake in Space Station Hangar.....	97
Figure 5-3.	IMV Using Thrusters to Traverse Ravine.....	97
Figure 5-4.	Cognitive Structure of an Intelligent Agent.....	106

INTRODUCTION

Purpose

The appropriate employment of automation and robotics (A&R) and human performance (HP) in space activities is a critical consideration for the success of large-scale operations. Operations of this type include construction of space platforms, assembly of Mars vehicles, preparation and maintenance of planetary sites and the utilization of extraterrestrial resources (mining of other planets or moons). The integration scenarios currently under consideration require complex operational efforts in space to deploy, assemble and handle systems of various kinds. These operations will involve humans and machine in combination to achieve the best possible effectiveness of the overall system.

Accomplishment of these tasks entirely by EVA is almost doomed to failure. This is from a technical point of view as well as a cost point of view. Safety issues often get in the way of performing the mission objectives reliably and cost effectively. An appropriate mix of A&R and human performance is required. The routine and repetitive tasks should be performed by robotic devices.

The Special Assessment Agent (SAA) for Automation & Robotics/Human Performance was chartered to focus on critical problems and/or high leverage areas in the Office of Exploration case study contexts. In this role, the SAA identified and evaluated conventional and unconventional systems, technology, configurations and technical options. In general, the goal of the assessment was to provide system analysis and design capability to enable effective allocation of functions between humans and machines for the operation of OEXP-type missions. The strategy was to identify the barrier issues, to determine the high leverage opportunities, and to evaluate specific applications. This was an iterative process that incorporated new data as it became available.

Scope

The scope of this report is limited to:

- 1. Assessing the feasibility of the assumptions for crew productivity during the intra-vehicular activities and extra-vehicular activities.**
- 2. Estimating the appropriate level of automation and robotics to accomplish balanced man-machine, cost-effective operations in space.**
- 3. Identifying areas where conceptually different approaches to the use of people and machines can leverage the benefits of the scenarios.**
- 4. Recommending modifications to scenarios or developing new scenarios that will improve the expected benefits.**

The FY89 special assessments are grouped into the five categories shown in Figure 1-1. The high level system analysis for Automation & Robotics (A&R) and Human Performance (HP) were performed under the Case Studies Technology Assessment category, whereas the detailed analyses for the critical systems and high leverage development areas were performed under the appropriate operations categories (In-Space Vehicle Operations or Planetary Surface Operations). The analysis activities planned for the Science Operations technology areas were deferred to FY90 studies. The remaining activities such as analytic tool development, graphics/video demonstrations and intelligent communicating systems software architecture were performed under the Simulation & Validations category.

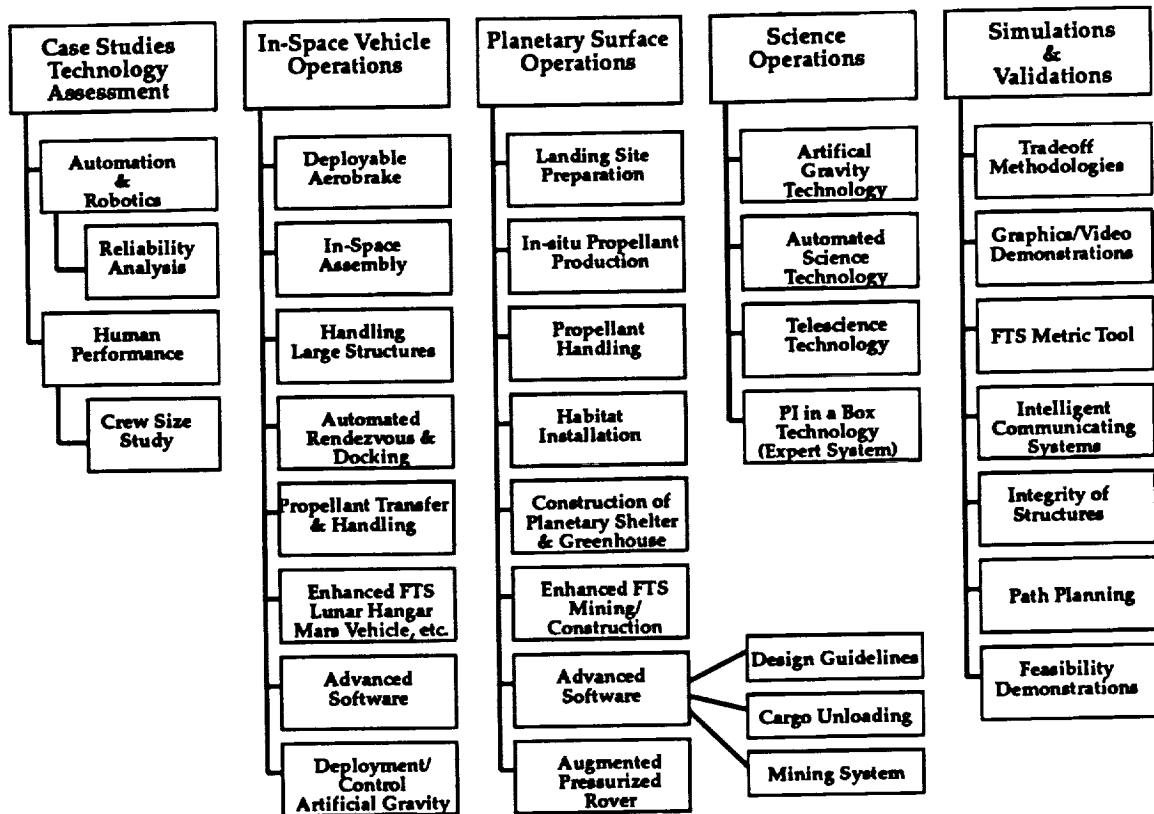

Figure 1-1. Special Assessments

1.0 CASE STUDIES TECHNOLOGY ASSESSMENT

To perform the trade-off analyses, it was necessary to develop A&R concepts for the critical systems and high leverage opportunity areas. These concepts provide a basis to evaluate the technology needs. These technology needs were presented to the EXTWG. Crew size tradeoff studies were performed to evaluate relative mission success, human safety, mission costs and launch weights.

1.1 AUTOMATION and ROBOTICS

In performing these assessments, workshops were held with each of the Integrating Agents to discuss their A&R issues and concerns. From this information, the A&R barriers (general and specific), critical technologies, and high leverage areas were identified and prioritized.

1.1.1 Barriers

General barriers to mission success were identified. The high level ones are the following:

- Current A&R technology is limited to handling the complex mission requirements for assembly, service and repair.
- A cost-effective approach is missing for handling increasing reliance on A&R.

The specific barriers to mission success include:

- Difficulties in handling large structures in micro-gravity environment.
- Difficulties in handling drifting objects.
- System inaccuracies.
- Man-machine controller interface inefficiencies.
- Limited flexibility/versatility in current A&R.
- Problems in identification.
- Communication delay problems.

1.1.2 Critical Concepts and Results

1.1.2.1 Critical Concepts Areas

Critical concepts are capabilities that must exist to meet the requirements of the case studies. Critical system development areas identified include:

1. Expert diagnostics for large scale space systems.
2. A&R/Human Performance analysis tools for optimizing mission operations.
3. Mobile, cooperative A&R systems for performing construction, maintenance, and repair tasks.
4. Application-specific A&R such as automated propellant transfer/tank handling, autonomous rendezvous and soft docking, automated artificial gravity systems, deployment and mass balance, autonomous landing systems, etc.

1.1.2.2 Development Results

Critical concept development results for A&R can be broken down into two groups, one for in-space operations and the other for planetary operations.

Development results for in-space operations are:

1. Automated assembly approach for the aerobrake.
2. Modular thruster packs for handling large structures in space.
3. Automated "soft" rendezvous and docking approach.
4. Manned/unmanned multi-arm robotic vehicle for assembly, maintenance, repair and rescue.
5. Automated propellant handling and tank transfer approaches.

6. On-orbit refueling methods.
7. Automated mission operations/FDIR (fault detection, isolation and recovery) architecture.
8. Automated artificial gravity deployment and mass control methods.

For planetary A&R:

1. Manned/unmanned multi-arm vehicle for construction, servicing, repair and rescue.
2. Automated operation/FDIR architecture.
3. Dust contamination control methods.

1.1.3 High Leverage Areas and Results

1.1.3.1 High Leverage Areas

High-leverage opportunity areas are those areas that offer significant advantages to the OEXP case studies but do not critically affect operations. The high-leverage areas identified and analyzed in this report are:

1. Automated equipment/techniques for repetitive element level assembly.
2. Telerobotic equipment/techniques for vehicle level assembly.
3. Automated acquisition and analysis of science data.
4. Telerobotic equipment for site preparation and construction.
5. Telerobotic equipment for mining and propellant production.
6. Advanced engineering controllers to provide semi-autonomous operation capability.

7. Intelligent cooperating systems for performing construction, maintenance, and repair operations.
8. Intelligent maintenance systems.
9. Smart sensors for testing, validating, and monitoring the structural and operational integrity of space systems.

1.1.3.2 Development Results

The high-leverage development results are also broken down into two groups. One group is for In-space A&R and the other is for Planetary A&R.

In-space A&R:

1. Deployable aerobrake concepts.
2. Advanced engineering controllers (AI/Expert systems) concepts for handling large flexible structures; for manipulating in the presence of mechanical vibrations; and for cooperative multi-robotic control.
3. Intelligent cooperating robotic concepts for performing construction tasks.
4. Smart sensors.
5. Intelligent maintenance robot.

Planetary A&R:

1. Automated payload unloading and construction approaches.
2. Alternative robotic concepts for performing construction tasks.
3. Automated landing site preparation approaches.
4. Automated habitat/radiation shield installation approaches.

5. Automated mining /benefication approaches.
6. Intelligent cooperating system for mining.
7. Automated LOX production.
8. Automated propellant handling and tank transfer.
9. Deployable habitat and greenhouse concepts.
10. Transferable, deployable landing pad concepts.
11. Advanced engineering controllers (AI/Expert systems).
12. Intelligent maintenance robot.
13. Automated approaches for power handling and storage.

All of the above ideas for critical concept and high leverage developments are discussed in more detail later in the report.

1.2 GENERAL AUTOMATION & ROBOTIC ISSUES

1.2.1 Automation & Robotic Definitions

Definitions of some commonly used terms in automation and robotics are given below:

Intelligence – The ability to understand and learn or to deal with new or challenging situations.

Teleoperator – A general purpose, dexterous machine at a distance controlled through telecommunication by a human.

Teleoperation – Performing tasks with a teleoperator.

Telepresence – The human sense of being at the remote work site provided by sensory feedback from a teleoperator.

Autonomous – Self governing or independent problem solving and decision making.

Robot – A reprogrammable, multifunctional machine designed to move material, parts, tools or specialized devices through variable programmed motions for the performance of a variety of tasks at various levels of autonomous operations under corresponding human control.

Telerobotic – A robot able to operate at a distance under control through telecommunications.

1.2.2 Functions

Many functions in space could be performed by astronauts in space suits at the task site. However, there are safety and dexterity concerns, especially for long duration EVA. Also, there are many tasks which require larger, more powerful systems and with greater performance duration. Such systems may be teleoperated from a control station or range to robotic systems which require only intermittent supervisory control.

1.2.2.1 EVA Functions

EVA operations require at least two astronauts with at most moderate communication time delay (up to lunar distances) from a control station. There must be at least one control operator in continuing attendance. The control station may be on Earth, in orbit, or on a planetary surface. It requires display feedback systems about the remote operations and a voice input system for uplink communication. The astronauts at the worksite have suitable life support systems and tools to handle and manipulate objects which should be designed "astronaut friendly". The size of the handled objects is limited to "man size", and the operating cycle may reach a duration of a maximum of six hours.

1.2.2.2 Teleoperated Functions

Many tasks require two cooperating systems, such as two astronauts or two robotic devices, at the work site. For two teleoperated robotic devices, we require in the control station one supervisory operator and two dedicated operators with display feedback, force feedback and dedicated manipulative input systems. The communication time delay is restricted to less than one second and preferably to less than one half of a second to avoid control instabilities. For tasks which require only one teleoperated robotic device, at least one operator and some time of the supervisor in the control station can be removed. If the operators can be rotated in shifts, the operating cycle is unlimited.

If autonomous capabilities are added to the robotic devices at the remote site, the communication time delay can be increased accordingly. The operators in the control station then take on functions of supervisors providing intermittent supervisory monitoring and control. This way the time or number of operators may be reduced.

In any case, the objects to be handled should be designed to be "robot friendly". Both the astronauts and robotic devices are expected to use tools. The objects to be handled should accordingly be designed tool friendly, while the tools should be designed either astronaut or robot friendly.

1.2.3 Design Guidelines

General guidelines are presented for automation and robotics. These guidelines would help to make the assembly "robot friendly". Modular design and self deployment techniques for structures, substructures, vehicles, machinery etc. should be used to the greatest degree possible. An example of self deployment is automated beam and truss building. In-space assembly is generally easier with fewer and larger objects than with many and smaller objects. Rendezvous and mating techniques with standardized interfaces should be used where possible and complexity should be avoided.

All objects that need to be manipulated should be designed EVA and robot friendly. They should be clearly labeled and easily identifiable from arbitrary orientation. They should be designed for easy grasping which is important for items to be picked up and for crawling robots and astronauts.

Unique operations and tasks requiring circumspection should not be automated. This task category includes replacements of modules, repairs etc. Unique operations are relatively expensive to automate and circumspection may require artificial intelligent technologies which are not always readily available. Recurring operations and definable tasks such as system monitoring, fault diagnosis, house keeping etc. should be automated to the fullest degree possible.

Software engineering and maintenance are lead items for all automation and robotic systems. Software systems should be conceptualized and designed in conjunction with the associated operational hardware systems.

The types of operations required for the assembly of systems in space are strongly influenced by the designer during the design process. The decisions made by the designer will determine whether the system can be assembled in a cost effective manner and in what modes (i.e. teleoperated, automated) the assembly can be accomplished. Irrespective of the particular assembly mode the following is a brief summary of guidelines which should be considered by designers.

Assembly is the combination of components into a product including the auxiliary work needed to prepare for, during and after production. The following operations are usually involved:

- 1. Storing of parts to be assembled in a systematic manner. Automatic assembly also requires the programmed supply of parts and connecting elements.**
- 2. Handling of components, including identifying the part by human or robot, picking up the part and moving the part to the assembly point.**
- 3. Positioning and aligning.**
- 4. Joining parts by providing appropriate connections.**
- 5. Adjusting to equalize tolerances, restore the required play etc.**
- 6. Securing the assembled parts against unwanted movements under operation loads.**
- 7. Inspecting. Depending on the degree of automation, various testing and measuring operations must be performed, possibly between individual assembly operations.**

These operations are involved in every assembly process. Their importance, sequence and frequency depends on the number of units and the degree of automation.

It is advantageous to standardize the necessary assembly operations. Such standardization means using the minimum number of assembly techniques and assembly tools. A further requirement is to provide for simple assembly operations. If the design permits parallel assembly of different subassemblies, then a considerable reduction in the overall assembly time is possible. In general, the designer should always aim at reducing the number of assembly operations. Since these operations depend on the number of individual components, the designer must try to:

1. Decrease the number of identical components.
2. Combine several components into one larger one.
3. Use preassembled assemblies.
4. Facilitate the combination of several operations.

Storing

This operation is particularly important in automatic assembly and is usually facilitated by the use of easily stacked components. Appropriate design measures include the provision of compatible stacking surfaces and of shapes ensuring the correct orientation of non-symmetrical parts.

Identifying

Avoid intermixing similar parts by the use of distinct shapes, dimensions of similar shapes, or finishes.

Picking Up

This operation is particularly important for automated assembly. By appropriately choosing design features the designer must avoid the entanglements of individual parts, prevent the nesting of individual parts and provide special features to ensure positive holding of the component.

Moving

The movement of parts to the assembly site is greatly influenced by the size, weight and type of the part. However, the designer should aim for short distances, good safety provisions, simple handling methods and easy transport.

Positioning

In both orienting and aligning, the design should aim for symmetry if no preferential position is required. Distinguish permissible or prescribed positions by surface marks or by the shape of the locating surfaces etc. Aim for automatic alignment of joints and if that is not possible provide adjustable joints.

Joining

Considerations are:

1. Joints that have to be disassembled frequently are equipped with easily separable connectors
2. Only those joints that are rarely or never disassembled use complicated separate connections (welds)
3. Positioning is combined with joining where possible
4. Flexible or compensating elements can be used to accommodate lack of fit between stiff components
5. A minimum number of tools should be used
6. Easy access to the locating surfaces and visual inspection are possible
7. Simple and short movements at the locating surfaces are facilitated
8. Special insertion facilities are provided
9. Simultaneous fitting operation and double restraint requirements are avoided.

Four basic methods for joining are:

1. Bolted
2. Pinned and Bolted
3. Welded
4. Space Station interface (as used for clamping vehicle habitat modules together).

Adjusting

The system should be designed to provide sensitive, repeatable adjustments. Avoid adjustments that affect previous adjustments.

Securing

To lock the joints against unwanted movements due to operating loads it is advisable to choose self-locking joints or to provide such additional form-fitting or frictional locks as can be assembled without great cost.

Inspecting

The designer must also provide for:

1. Simple checks on critical requirements.
2. Inspection and further adjustments without dismantling already assembled parts.

Some general design recommendations for ease of robotic assembly are:

1. Factor in remote robotic assembly considerations when making every design decision.
2. Maximize commonality of components, fittings, fasteners, interfaces, protocols etc.

3. Adapt all assembly steps, fasteners and part identification for robotic use.
4. Design for modular assembly of finished pretested elements.
5. Design self-contained subsystems and minimize complex functional interconnects.
6. Provide no-cascading access/changeout paths.
7. Incorporate handshaking, self-test sensing into all systems.
8. Make full use of ground fabrication, testing, monitoring and control. Minimize the orbital effort required.

1.3 HUMAN PERFORMANCE

1.3.1 Introduction

Future NASA missions will include sending humans to explore our solar system. The number of crewmembers is a critical factor to mission success.

Figure 1-2 outlines basic assumptions about the advantages and disadvantages of large and small crew sizes. Mission planners need techniques and tools to evaluate and select the best crew size for solar system exploration missions. The goal of this study section is to develop and test these techniques.

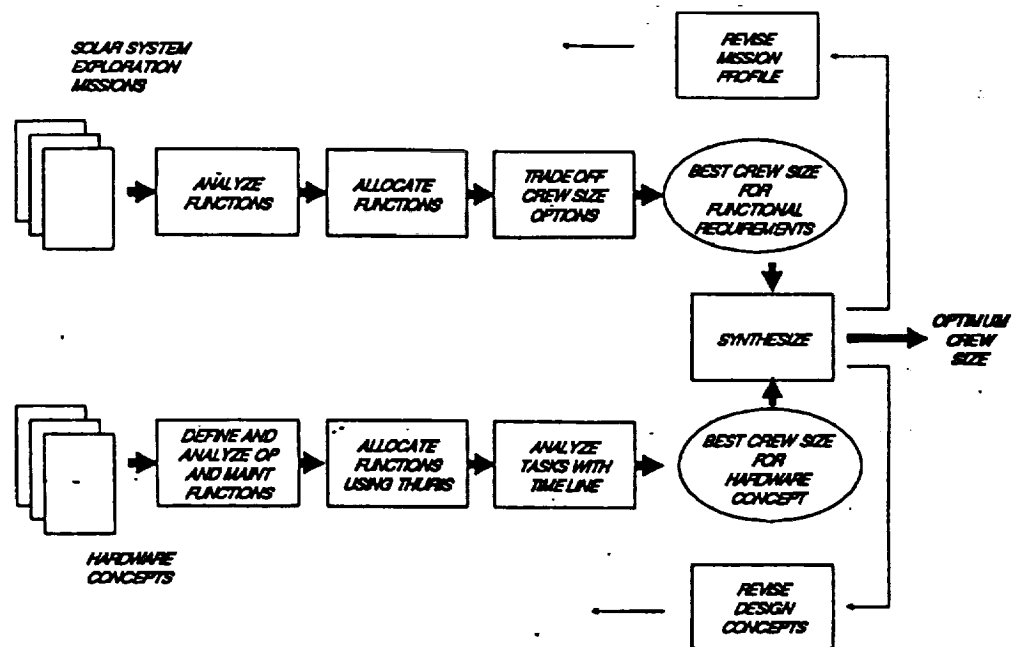

Figure 1-2. Process for Functional and Task Requirements Analyses

The following proposes two techniques for determining crew size. Each technique is described in detail and then tested on sample Mars missions. Also included are surveys of computer tools used to speed crew size evaluation. An assessment of the proposed crew size selection techniques and recommended ways for improvement is provided.

The present study considers only optimal human performance without consideration of possible performance decrements due to physiological, psychological, or social problems. Life sciences and human factors research is required to determine the relationship between crew size and physical, mental, and social health. The results of this research must be combined with the results of the function and task requirement analyses.

1.3.2 Techniques to Determine Solar System Exploration Crew Size

1.3.2.1 Proposed Techniques to Determine Crew Size

This study proposes two techniques for evaluation of crew size options:

1. Functional Requirements Analysis to evaluate crew size options for completing specified functions in a mission.
2. Task Requirements Analysis to evaluate crew size options for doing operating and maintenance tasks on a specific hardware design.

The terms "task," "function," and "activity." as used in the context of this section are defined as follows:

- A function is a general purpose or intent to meet a defined mission.
- An activity is an organized procedure or process. A sequence of activities comprise a function. An activity can be done by a human, machine, or human machine combination.
- A task is an activity accomplished by a human.

Solar system exploration planners and designers can use both the functional requirements analysis and task requirements analysis to select mission crew size. Functional requirements analyses made early in the development of a system helps planners determine the best crew size for a mission. Later, as design concepts are developed, analysts can use the task requirements analyses to evaluate and determine the optimum crew size to operate and maintain the design concepts. System developers can then compare the crew size estimates from the functional requirements analyses and task requirements

analyses. If the two estimates differ substantially, mission planners may choose to alter mission plans or revise design concepts.

Function and task requirements analyses produce other information besides crew size evaluations. The analyses give detailed information on the interface between the crew and the equipment they use. The information includes physical and mental demands on the human, potential safety problems, and displays and controls required to do tasks successfully. The data serves as design guidelines.

The following two sections describe functional requirements analysis and task requirements analysis in detail. After the descriptions is an example using both techniques to select crew size for Mars missions. The example illustrates the utility of both techniques and areas where these techniques can be improved.

1.3.2.1.1 Functional Requirements Analysis

Functional requirements analysis evaluates crew size options for completing specified functions in a mission. The analytical process is adapted from techniques used by the Department of Defense to analyze complex military systems. The following describes the functional requirements analysis process.

1. Define Functions – Define the solar system exploration functions. The 1988 Office of Exploration report outlines the functions in the mission case study descriptions . Figure 1-3 identifies these solar system exploration functions.
2. Describe Functions – Describe the functions in greater detail with functional flow block diagrams. A functional flow block diagram shows each function as a sequential set of activities. The activities describe what must be done in each function, rather than how the function should be done.

3. Analyze Functions – Prepare a Solar System Exploration Functional Analysis worksheet for each functional flow block. Figure 1-4 is an example worksheet. The first column is a detailed sequence of activities with decisions shown as diamonds and actions as circles. In column 2 are notes on requirements and goals for completing the activities. Column 3 defines how the activities are accomplished: the personnel and equipment that do the activities. In filling in this column, the analyst evaluated different crew size options using the following information resources:

- a. Human Factors data on human capabilities and limitations.**
- b. Coordination with the Automation and Robotics group at NASA Ames Research Center.**
- c. Information from other Code Z resources: past publications, telephone conversations, and coordination meetings.**

In column 4 the analyst noted advantages and disadvantages of the different crew size options.

4. Tradeoff Crew Size Options – Rate and trade off crew size options. The tradeoff study process is as follows:

- a. Select and weight parameters to evaluate crew size options. The tradeoff study used the following parameters:**

- Crew Safety**
- Mission Success**
- Launch Weight**
- Crew Support Costs**
- Crew Training and Selection Costs**
- Impact on Automation and Robotics Support Requirements**

The parameters were weighted according to their impact on the success of the solar system exploration program.

- b. Select crew size options. The tradeoff started with a baseline crew size. The baseline was usually the crew size in the case study descriptions. The other crew size options were the baseline plus one and two crewmembers and the baseline minus one and two crewmembers.**

c. Score all parameters for each crew size. The scores are relative to the baseline crew size:

- 5 = SIGNIFICANT IMPROVEMENT OVER
BASELINE CREW SIZE
- 4 = SOME IMPROVEMENT OVER BASELINE
- 3 = SAME AS BASELINE
- 2 = SOME DECREMENT OVER BASELINE
- 1 = SIGNIFICANT DECREMENT OVER BASELINE

d. Calculate a weighted score by multiplying the score times the parameter weight. Total the weighted score for each crew size. The crew size with the highest total weighted score is the best crew size.

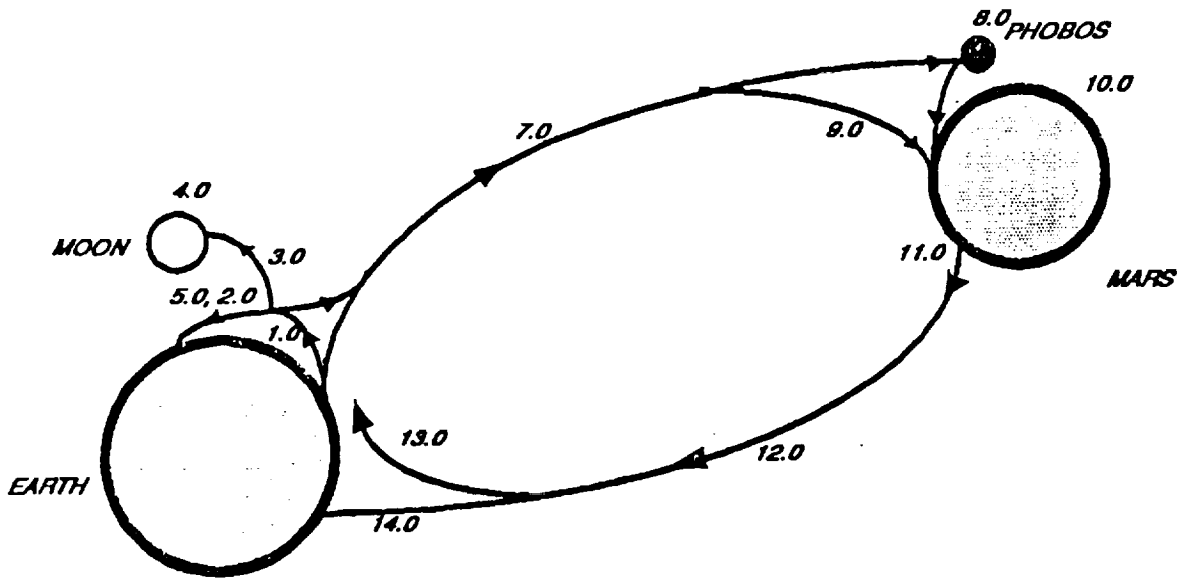

	CASE STUDIES			
	LUNAR EVOLUTION	MARS EXPEDITION	MARS EVOLUTION	LUNAR OASIS
1.0 EARTH TO LEO	X		X	X
2.0 NODE OPS - LUNAR SUPPORT	X			X
3.0 NODE TO MOON	X			X
4.0 LUNAR OPERATIONS	X			X
5.0 NODE OPS - MARS SUPPORT			X	
6.0 EARTH TO MARS INJECTION		X		
7.0 EARTH TO MARS TRANSIT		X	X	
8.0 PHOBOS OPERATIONS			X	
9.0 MARS TRANSIT TO MARS		X		
10.0 MARS SURFACE OPERATIONS		X	X	
11.0 MARS LAUNCH		X	X	
12.0 MARS TO EARTH TRANSIT		X	X	
13.0 MARS TRANSIT TO NODE			X	
14.0 MARS TRANSIT TO EARTH		X		

Figure 1-3. Solar System Exploration Functions

FUNCTION	REQUIREMENTS / GOALS	ALLOCATION CONCEPTS	ALLOCATION NOTES
<p>SELECT OPERATIONS SITE?</p> <p>PREPARE CONTACT POINTS FOR MANNED AND CARGO VEHICLES</p> <p>PREPARE PLANT SITE?</p> <p>PREPARE PLANT SITE</p> <p>①</p>	<p>NEED TEMPORARY HAB WHILE CONSTRUCTING PERMANENT. TEMP HAB MUST BE PROTECTED FROM ENVIRONMENT INCLUDING RADIATION</p> <p>②</p>	<p>USE MARS LANDER AS HAB DURING CONSTRUCTION</p> <p>PLACE LIGHTS AND NAV AIDS AT SITE USING SORTIE VEHICLE 2 EVA</p> <p>③</p>	<p>ASSUME THIS IS THE SECOND FLIGHT OF A MARS EVOLUTION. NO CREW HAS BEEN TO THE MARS SURFACE. ASSUME CREW OF 2 AND UP TO 1 YEAR STAY</p> <p>PROBLEMS WITH ONLY 2 CREW:</p> <p>1. BOTH EVA: PERFORMANCE RESTRICTED, CREW CANNOT RESPOND QUICKLY TO EMERGENCIES SUCH AS A FIRE OR LEAK IN THE TEMP HAB</p> <p>2. ONE EVA, ONE IVA: RESCUE OF EVA CREWMAN WOULD BE DELAYED BY TIME TO DON EVA GEAR</p> <p>3. BOTH IVA IN PRESSURIZED CAB: LIMITS CREW PERFORMANCE</p> <p>↓</p> <p>MINIMUM CREW SIZE IS 3</p> <p>④</p>

Figure 1-4. Example Worksheet for Functional Requirements Analysis

1.3.2.1.2 Task Requirements Analysis

Task requirements analysis evaluates crew size options for operating and maintaining a specific hardware design. System planners and designers can use the method to compare and select design ideas.

Task requirements analysis combines time line task analysis and a program called THURIS (The Human Role In Space). NASA Marshall Space Flight Center developed THURIS in 1984 to estimate the optimum crew size for the space station. THURIS accounts for crew capabilities and limitations, technology development, cost, and function demands.

The following briefly describes the task requirements analysis process.

1. **Define Activities** – Select a design concept and identify the activities to operate or maintain the design. List the activities in column 1 of the Solar System Exploration Functional Analysis worksheet shown in Figure 1-5. As with the functional requirements analysis, define the activities by what must be done and not how. For instance, the example in the next section will show triangular plates that must be screwed together to construct the geodesic dome. A robot or a human with a wrench could do the job. List only the activity (fasten triangular plates) in the first column of the Functional Analysis Worksheets.
2. **Categorize the Activities** – Categorize each activity as one of the 37 generic activities defined by THURIS. For example, the activity “fasten a screw” was categorized as THURIS generic activity 26: precision manipulation of objects. Record the activity category in column 2 in the Functional Analysis worksheets.
3. **Count THURIS Generic Activities** – Total each of the THURIS generic activities for the entire function and enter the total on the THURIS score sheet in Figure 1-6.
4. **Determine Automation Level** – Use the THURIS cost optimization curves to determine the automation level. Figure 1-7 lists the automation levels defined in THURIS. Figure 1-8 is an example THURIS cost optimization curve. If an activity occurs a specific number of times, then the activity warrants some automation level to be cost effective. In our example, fastening screws (THURIS generic activity number 26) occurred 1149 times. The most cost effective automation level is “augmented.”
5. **Allocate Activities** – Allocate the activities to humans and machines according to the automation level defined by THURIS. For example, fastening a screw is an augmented activity (according to THURIS) and was therefore allocated to a human with a powered wrench. Column 3 in the Functional Analysis worksheets (Figure 1-5) shows the allocations.

6. Task Analysis and Crew Size Selection – Finally, determine the best crew size using task time line analysis. Figure 1-9 is an example task time line worksheet. Crew tasks are in the right column of the time line worksheet. Next to the task, the analyst assigned a crewmember to do the task and estimated the task time. A letter (A, B, C) designates the crewmember and a bar progressing from left to right shows the time. Time line worksheets were used to examine different crew sizes and determine the best crew size to complete the function. The “best” crew size can do the task with the least total person-minutes. For instance, if one crewmember can do a task in 10 minutes (10 person-minutes) and two crewmembers can do a task in 6 minutes (12 person-minutes), then best crew size is one.

**SOLAR SYSTEM EXPLORATION
FUNCTIONAL ANALYSIS**

CASE: _____ PAGE 2 OF _____
 FUNCTIONAL BLOCK: 10.5 NAME: _____ DATE: _____ REV: _____

FUNCTION	REQUIREMENTS / GOALS	ALLOCATION CONCEPTS	ALLOCATION NOTES
<p>5A TRANSPORT FIRST FLOOR SUPPORT BEAMS TO BASE</p>	TGA 36 (18)	2 CREW CARRY BEAMS TO EDGE OF HOLE AND LOWER END DOWN	ASSUME 18 FLOOR SUPPORT ELEMENTS
6 POSITION AND LEVEL BEAMS	TGA 36, 25, 2, 26 (18) (18) (25) (25)	FOUNDATION BLOCKS HAVE CRADLE FOR BEAMS THAT SCREW UP AND DOWN FOR LEVELING	
7 ALL BEAMS IN CORRECT POSITION?	TGA 22 - (18)		
8 FASTEN BEAMS	TGA 26 - (108) MANIPULATION OF SMALL ITEMS	CAPTIVE SCREWS AND THREADED CRADLES ON FOUNDATION BLOCKS. CREW USES POWER DRIVER.	ASSUME 6 FASTENERS PER BEAM = 108 FASTENERS
9 ALL BEAMS SECURE?	TGA 22 - (54)	CREW VISUAL INSPECTION	
1	(2)	(3)	(4)

Figure 1-5. Example Task Requirements Analysis Worksheet

THURIS SCORE SHEET

0.5 ACCESSIBLE HABITAT
IN MAES

SYSTEM: GEDDESIC DOME

(STARTING POINT: ALL REQUIRED ACTIVITIES CAN BE PERFORMED MANUALLY BY EVA CREW)

Activity Name	Check if activity required	No. of Lines Performed	Man-machine categories								Technological Readiness (TR)	Cost rate for TR of 1	Years to IOC: TR of 1	
			□ Manual	○ Sup. period	△ Aug. period	+ Tele-operated	▽ Super-vised -ground-	▽ Super-vised -orb-	▽ Indep. period	▽ Indep. period				
	A	B	C	D	E	F	G	H	I	J	K	L		
1 Activate initial system operation														
2 Adjust align elements	✓	25	X											
3 Allocate assign distribute														
4 Apply remove biomedical sensor														
5 Communicate information														
6 Compensatory tracking														
7 Compute data														
8 Confirm verify procedure schedule/operations	✓	4	X											
9 Connect disconnect electrical interface														
10 Connect disconnect fluid interface														
11 Correlate data														
12 Deactivate terminate system operation														
13 Decode/encode data														
14 Define procedures schedules/operations														
15 Deploy retract appendage	✓	25			X									
16 Detect change in state or condition														
17 Display data														
18 Gather replace tools equipment	✓	2	X											
19 Handle inspect examine living organisms														
20 Implement procedures schedules														
21 Information processing														
22 Inspect observe	✓	430			X									
23 Measure /scale/ physical dimensions	✓	25	X											
24 Plot data														
25 Position module	✓	329			X									
26 Precision manipulation of objects	✓	1149			X									
27 Problem solving decision making/data analysis														
28 Pursuit tracking														
29 Release secure mechanical interface														
30 Remove module														
31 Remove replace covering														
32 Replace clean surface coatings														
33 Replenish materials														
34 Store record element														
35 Surgical manipulations														
36 Transport loaded	✓	615			X									
37 Transport unloaded														
Summary Data		2604	4	1	✓									
<input type="checkbox"/> Man-machine categories not appropriate to activity implementation	Total Required	Number of lines selected										Median Readiness Level	Program Cost Increase	Maximum No. of years
	M											U		

Figure 1-6. Example THURIS Worksheet

Manual	Unaided IVA/EVA, with simple (unpowered) hand tools
Supported	Requires use of supporting machinery or facilities to accomplish assigned tasks (e.g. manned maneuvering units and foot restraint devices)
Augmented	Amplification of human sensory or motor capabilities (powered tools, exo-skeletons, microscopes, etc.)
Teleoperated	Use of remotely controlled sensors and actuators allowing the human presence to be removed from the work site (remote manipulator systems, teleoperators, telefactories)
Supervised	Replacement of direct manual control of system operation with computer-directed functions although maintaining humans in supervisory control
Independent	Basically self-actuating, self-healing, independent operations minimizing requirement for direct human intervention (dependent on automation and artificial intelligence)

Figure 1-7. THURIS Automation Levels

ACTIVITY NUMBER 26-PRECISION MANIPULATION OF OBJECTS
CUMULATIVE COST VS. FREQUENCY

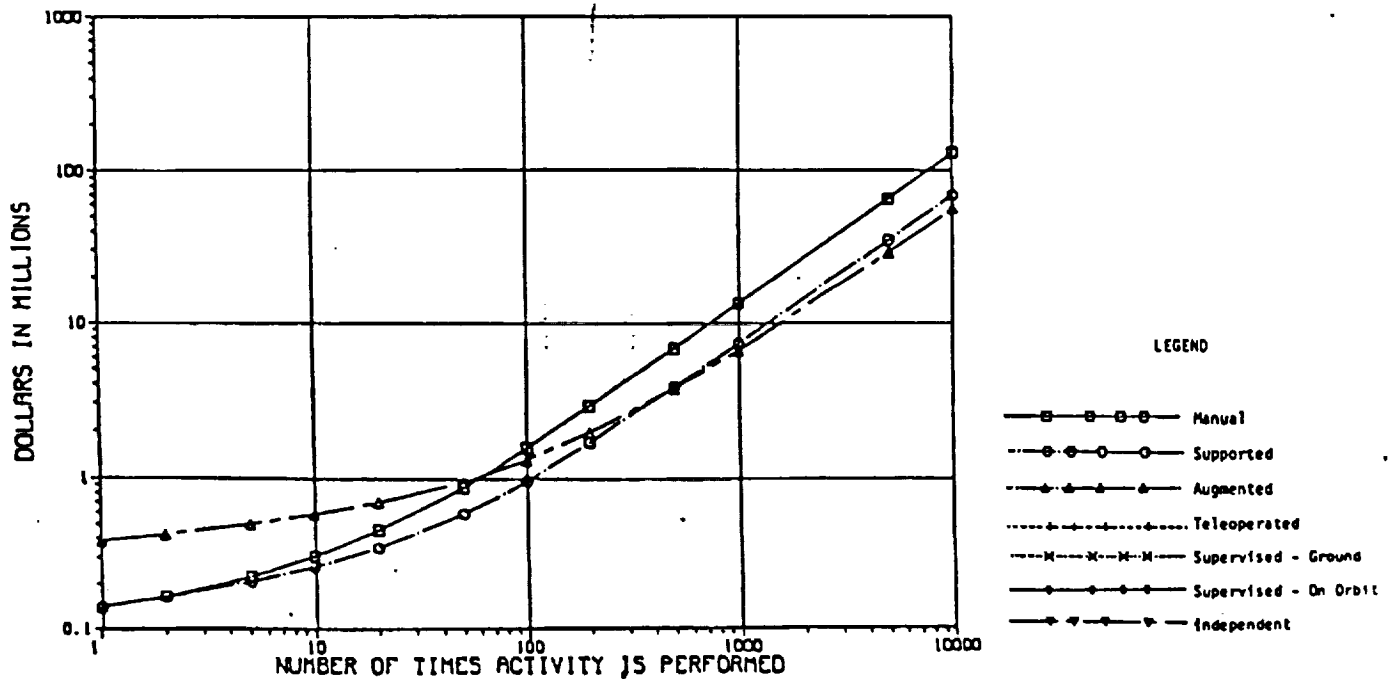

Figure 1-8. Example THURIS Cost Optimization Curve

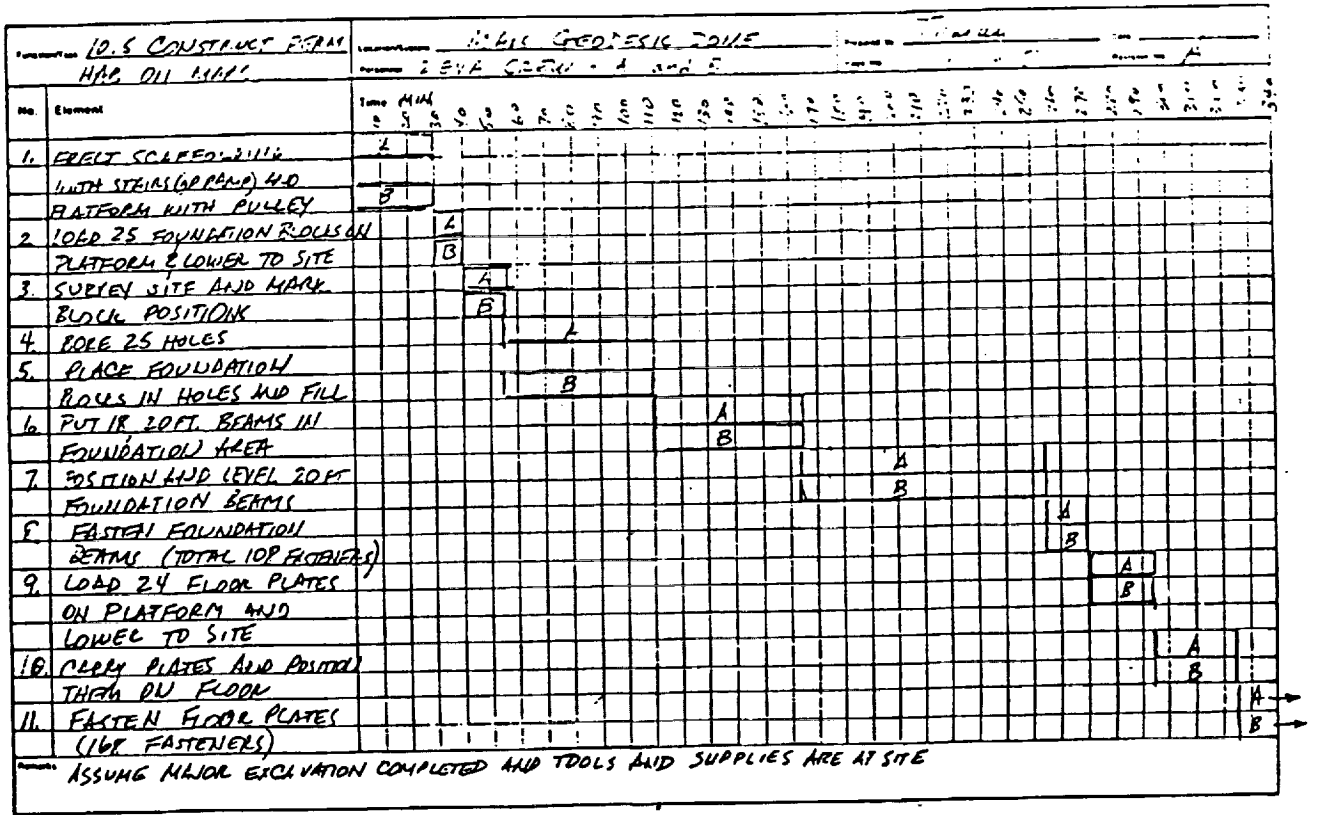

Figure 1-9. Example Task Time Line Worksheet

1.3.2.2 Example Application of Proposed Techniques to Determine Crew Size

This study used the Mars mission case studies to evaluate the two proposed techniques to determine crew size. The following section gives the results of the functional requirements analysis and task requirements analysis. Evaluation of the techniques and recommendations for improvement are in Section 1.3.4

1.3.2.2.1 Functional Requirements Analysis of Mars Mission

Functions representing three Mars mission phases were analysed:

1. Construction of an Earth/Mars Transit Vehicle in a Low Earth Orbit (LEO)
2. Transit to Mars
3. Mars Surface Operations

The specific functions were selected because they have the greatest impact on the Mars missions. The analysis results should provide a good guide for selecting Mars mission crew sizes.

Figure 1-10 combines the function analysis crew size summary data for Mars mission vehicle construction, transit, and surface functions. The best vehicle construction crew size is two. Three is a compromise crew size to go to Mars. This assumes Mars surface habitat construction and exploration have equal importance and there are no crewmembers orbiting Mars. If we assume Mars surface exploration functions are more important than habitat construction, the crew size should be four.

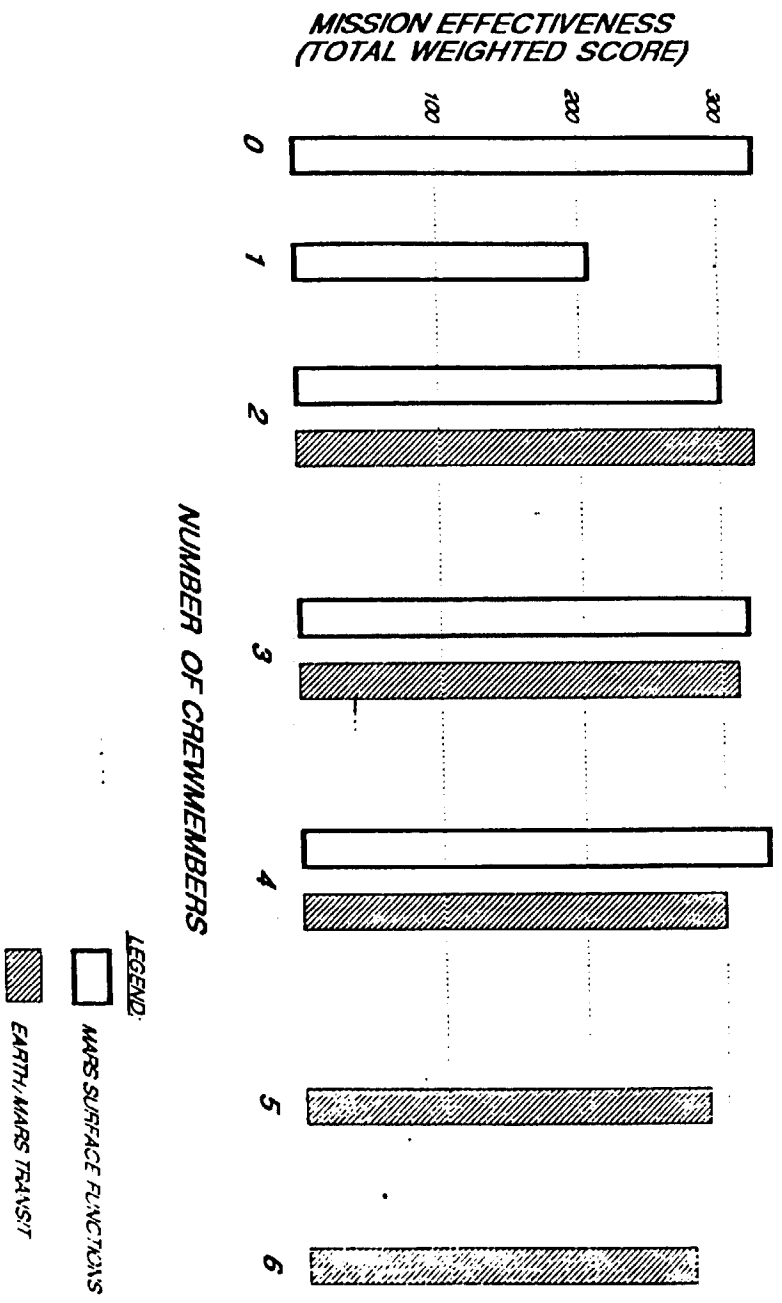

Figure 1-10. Function Analysis Crew Size Summary Data

1.3.2.2.2 Task Requirements Analysis of Mars Mission

This study estimated crew size for performing tasks on three design concepts:

- Assemble a PETAL AEROBRAKE on the Mars transit vehicle in low Earth orbit.
- Operate and maintain a SALAD MACHINE during Earth / Mars transit.
- Construct a GEODESIC DOME structure on the Mars surface.

The following gives the results of the three analyses.

Aerobrake Assembly

The aerobrake design selected for analysis was developed by the Ames Research Center Automation and Robotics personnel. Figures 1-11 through 1-13 show the design. The concept has 12 petals hinged at the hub. NASA would launch the aerobrake with the petals folded against the vehicle. Once in LEO, the aerobrake petals are deployed. The petals are slightly oversized to make them overlap. The overlapping petals fasten together for structural integrity.

Task requirements analysis determined three crewmembers should assemble the aerobrake. Fewer crewmembers would require an automation level higher than allowed by THURIS. Task analysis showed adding a fourth crewmember would be inefficient because the fourth crewmember would be idle. Time line estimates determined three crewmembers could complete the task in 6 hours and 29 minutes (1167 person-minutes). If we assume \$2500 a person-minute, the labor cost is \$2,917,500.

Figure 1-11. Petal Aerobrake Concept Stowed for Earth to LEO

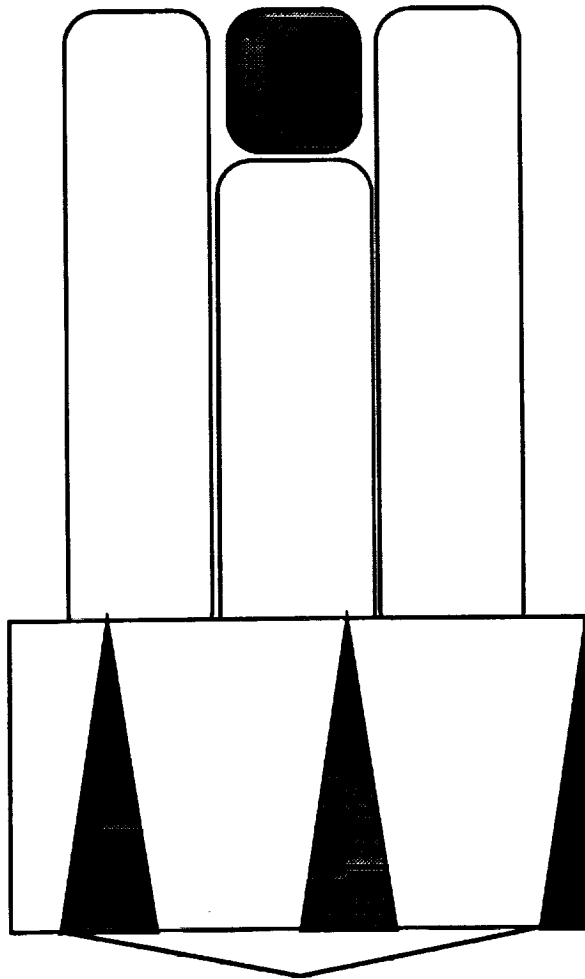

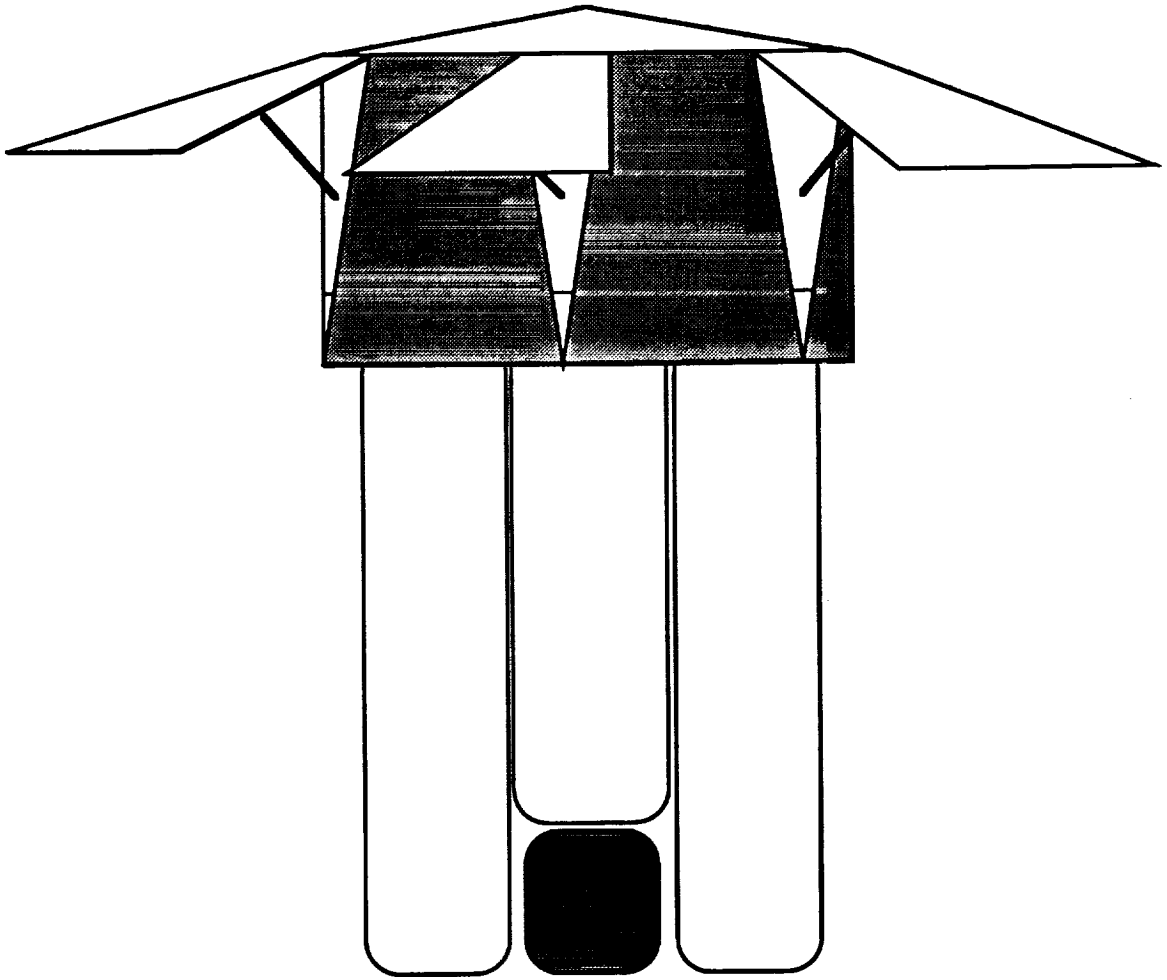

Figure 1-12. Aerobrake Deploying at LEO

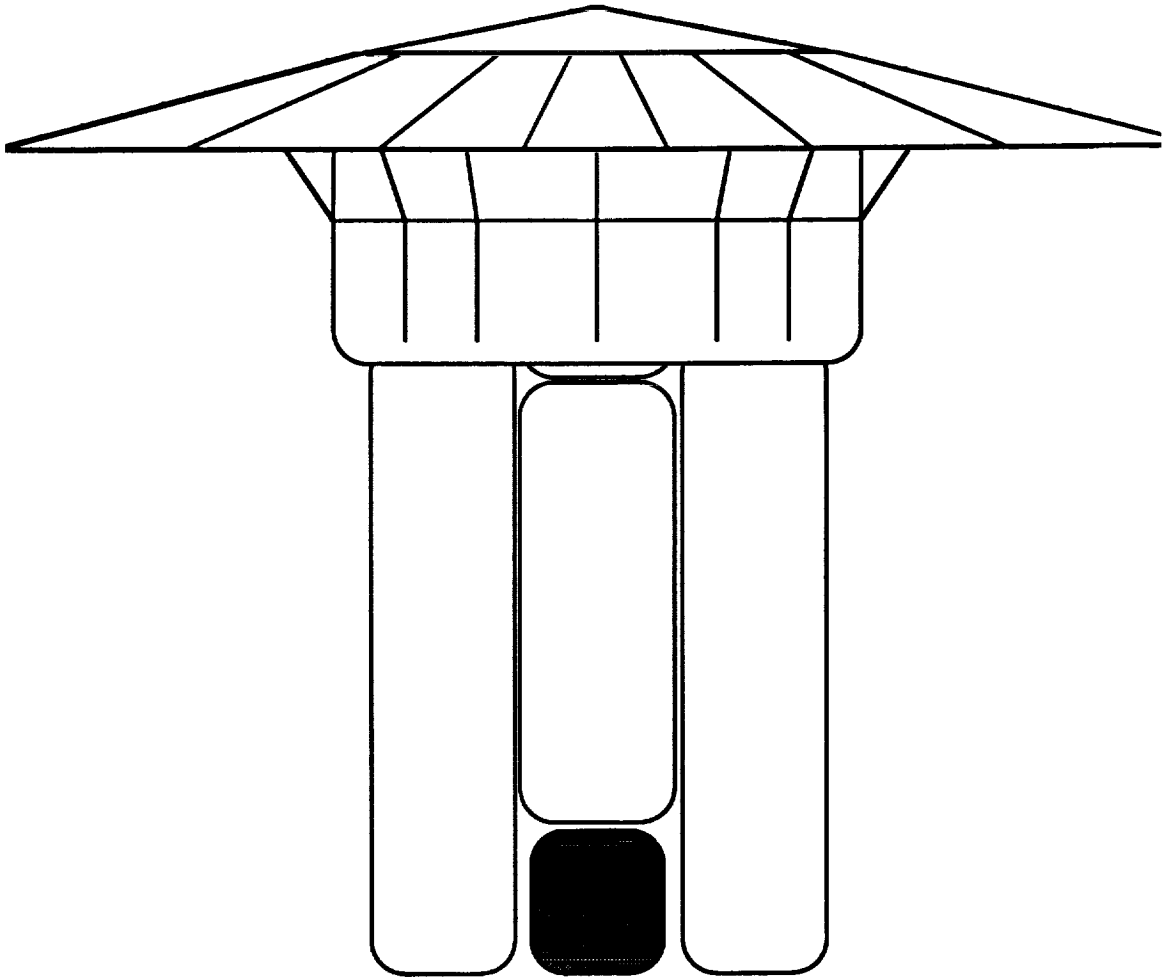

Figure 1-13. Aerobrake Deployed for LEO to Mars

Salad Machine Operation

The life support system component selected for analysis is the "Salad Machine" under development at Ames Research Center, see Figures 1-14 through 1-16. Ames is designing the Salad Machine for the Space Station Freedom but the machine could be adapted as a supplement food system for an Earth-Mars transit vehicle.

The Salad Machine has no significant impact on crew size. The task time line analysis determined the crew will need very little time to operate and maintain the Salad Machine. It requires roughly 3 minutes a day for harvesting plants and transferring from germination to growth chambers. Every 20 days the Salad Machine will require roughly 30 minutes for servicing (filter changes, system cleaning, and replenishing consumables in machine).

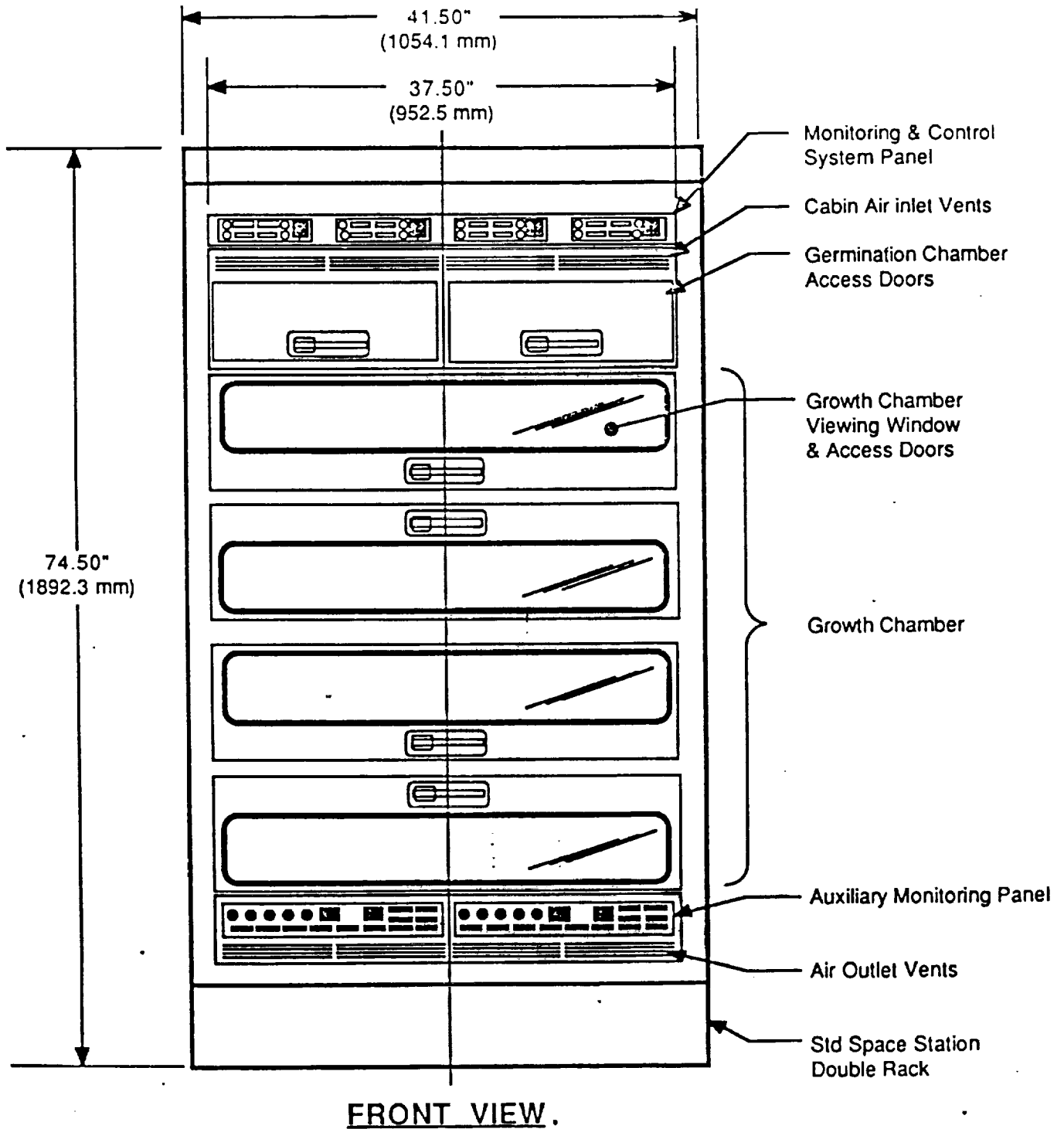

Figure 1-14. Space Station Freedom Food Supplement System

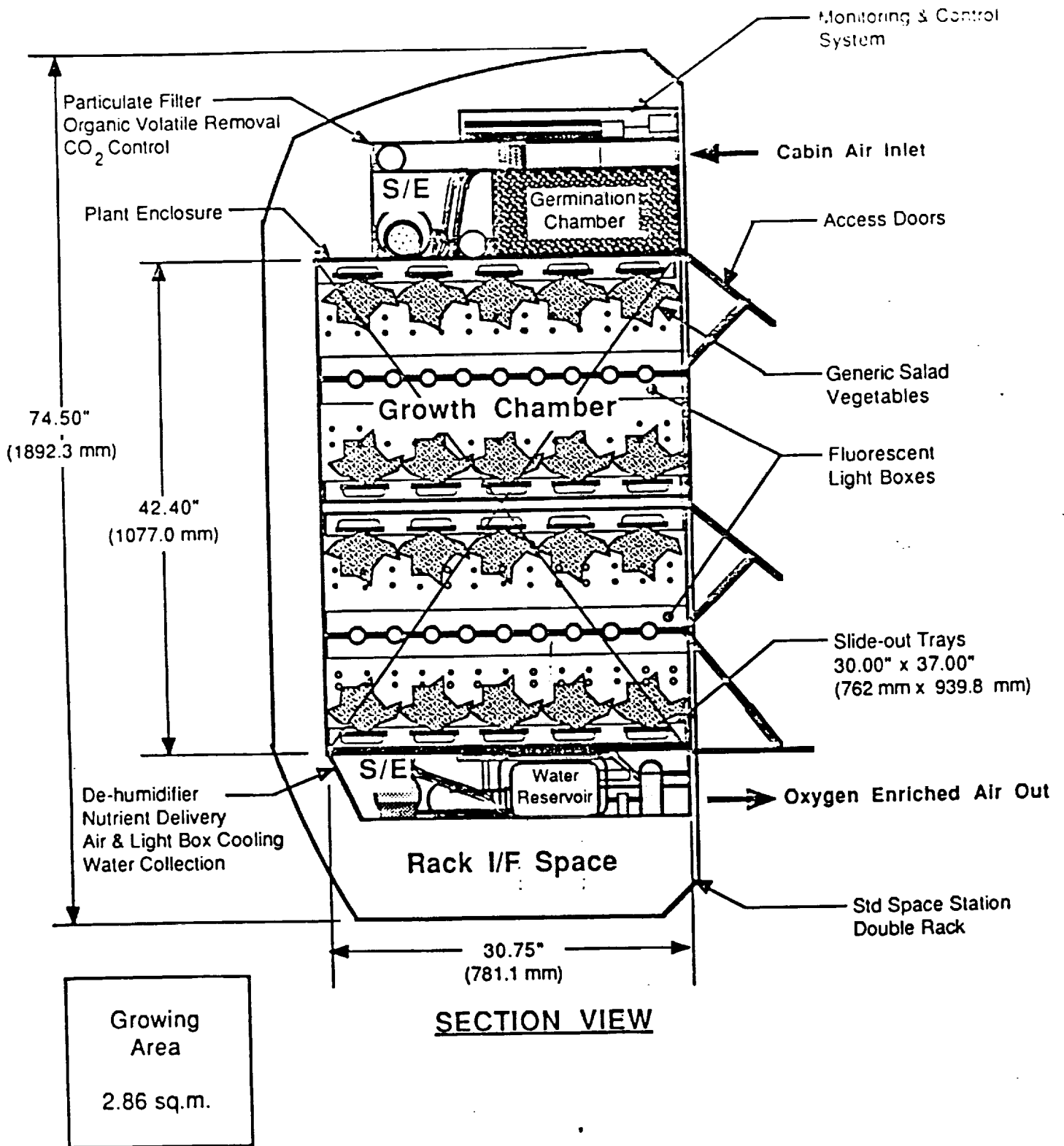

Figure 1-15. Cross Section of Salad Machine

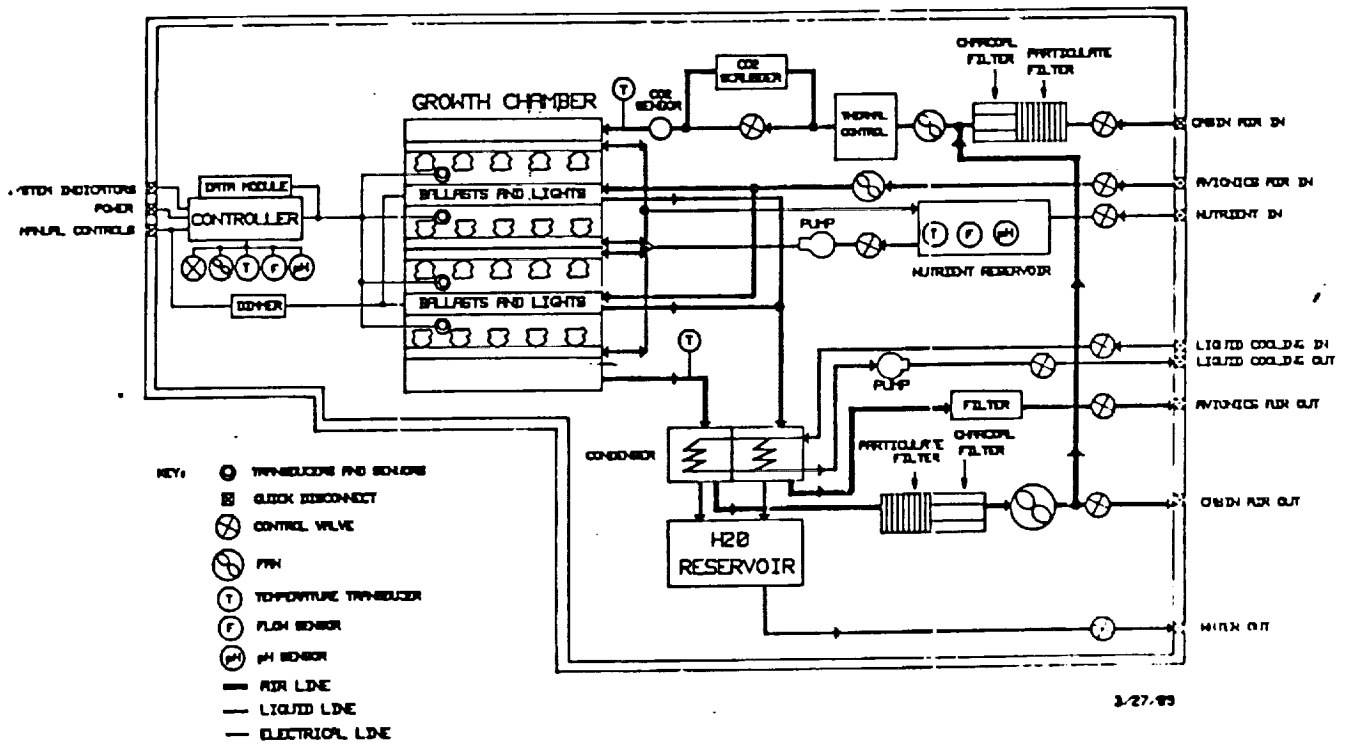

Figure 1-16. Salad Machine Block Diagram

Geodesic Dome Construction

The structure design selected for analyses was the geodesic dome. Figure 1-17 shows the dome. The dome has two levels with roughly 2000 square feet floor space. Foundation blocks set in the soil hold floor support beams. Floor plates fasten to the floor support beams. The second floor is also beams and floor plates supported from the first floor by posts. The shell is approximately 232 identical triangles fastened to each other with two fasteners per side. The triangles are equilateral and the sides are roughly six feet long.

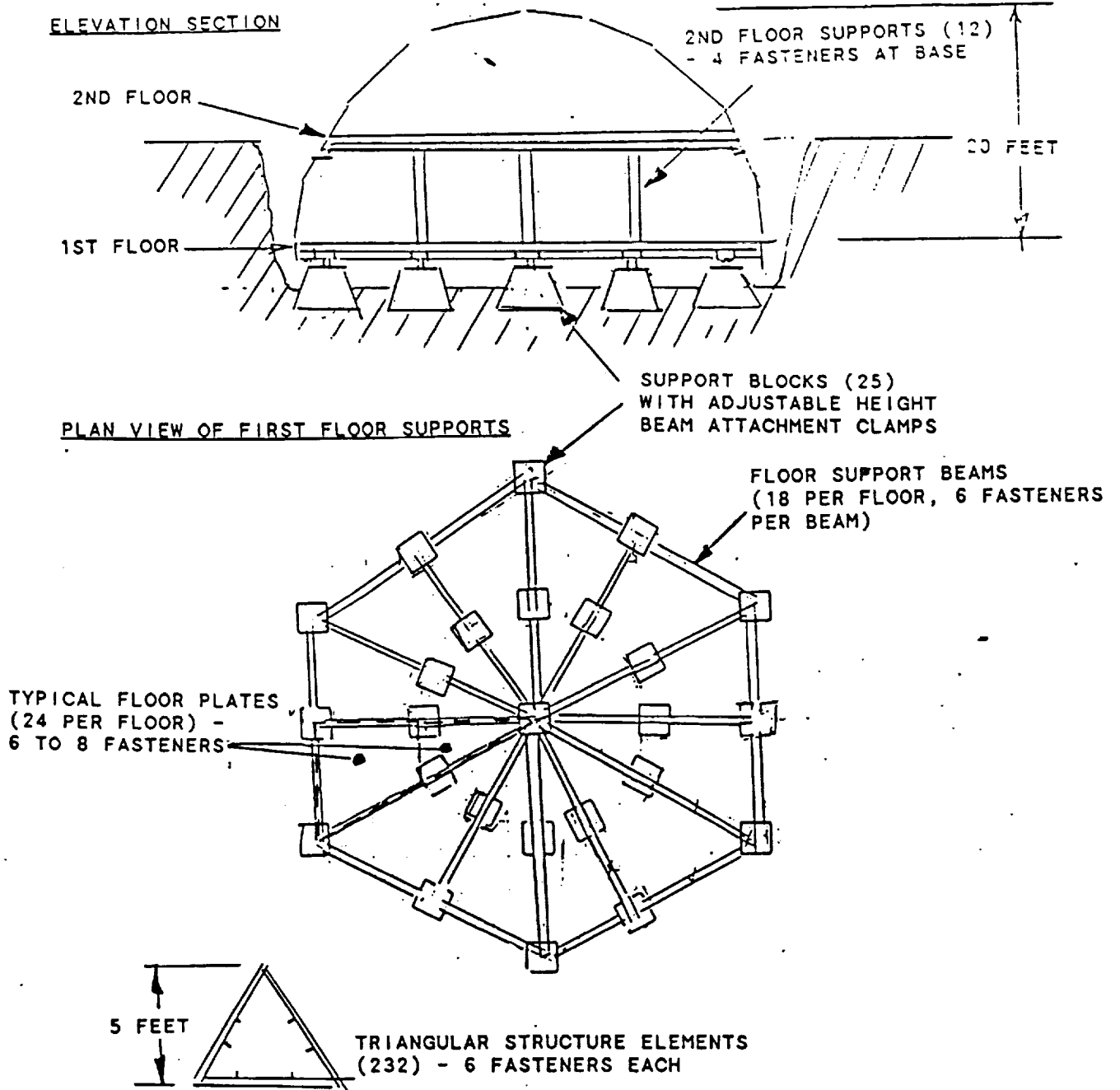

Figure 1-17. Geodesic Dome Structure Design

Below are the task requirements and task time line analysis results for three crew sizes. The estimated costs are based on \$2500 a person-minute.

CONSTRUCTION CREW SIZE	ELAPSED CONSTRUCTION TIME	TOTAL PERSONNEL TIME	ESTIMATED PERSONNEL COSTS
2	1380 MIN.	2760 PERSON-MIN	\$6,980,000
3	880 MIN.	2640 PERSON-MIN	\$6,600,000
4	650 MIN.	2600 PERSON-MIN	\$6,500,000

These results show the best crew size to construct the geodesic dome is four. Five crewmembers would require more crew time because most tasks are two person tasks. A fifth person would be idle for extensive periods.

1.3.2.2.3 Combining the Results of Example Functional Requirements Analyses and Task Requirements Analyses

The following conclusions can be made by combining the results of the above Mars mission function and task requirements analyses.

1. The Mars surface habitat should be prefabricated or assembled telerobotically. The geodesic dome design concept is undesirable because efficient construction requires four EVA crewmembers.
2. The salad machine will have no impact on crew size and therefore cannot be evaluated on the basis of crew size demands.
3. The petal aerobrake design concept requires three crewmembers (two EVA) to deploy. Other concepts should be developed that can be cost effectively deployed with automation or telerobotics.

1.3.2.3 Human Factors Design Guidelines

The function and task requirements analyses described in the preceding sections provide information for evaluation of crew size options. The analyses also provide information for designing equipment compatible with the capabilities and limitations of the human operators and maintainers. Human factors design guidelines have been developed from the function and task requirements analyses. These guidelines will become more detailed with further research and analysis of function and task requirements. The conclusion of this report has recommendations for specific guidelines needed in the future.

1.3.3 Computer Tools

1.3.3.1 Introduction to Computer Tool Survey

Computer tools will increase the speed and efficiency of human performance analysis and crew size selection and would be a valuable aid to record analytical data, evaluate design concepts, and update analyses. Figure 1-18. shows typical human factors analysis steps (in boxes) and the computer tools that would be helpful (in ovals). The step "Allocate Functions and Select Crew Size" is highlighted for reference.

1.3.3.2 Survey Results

The study surveyed one hundred and twenty eight computer programs. Twenty three programs were selected because they have potential use for human factors analyses (including crew size selection) of the solar system exploration program.

The Air Force is in the process of surveying human factors computer software. The project director is Mr. Kenneth Potempa at Brooks AFB.

1.3.4 Results and Conclusions

1.3.4.1 Crew Size Selections Techniques

Both techniques (Functional Requirements Analysis and Task Requirements Analysis) are able to evaluate crew size options and help the analyst select the best option. However, both techniques need improvement:

1. **Functional Requirements Analysis** – The functional requirements analysis requires the analyst to compare crew sizes on a relative basis: is one crew size the same, better, or worse than another crew size? Data are lacking to make absolute evaluations of crew size options. Analysts need detailed models for technology development costs and costs for crew training, crew launch and crew support.
2. **Task Requirements Analysis** – THURIS is an excellent program but needs improvement:
 - a. **Computerize THURIS** for use on a personal computer – THURIS was developed to operate on an older DEC system that is no longer available. A computerized tool is essential for performing extensive tradeoff studies in a systemic fashion.
 - b. **Update cost assumptions** – THURIS cost factors are out-dated and do not apply to solar system exploration missions. THURIS primarily addresses the space station program and does not consider the cost to build, launch, and support a Mars or Lunar mission.
 - c. **Update technology assumptions** – NASA completed THURIS in 1984. The technology assumptions are out-dated.

1.3.4.2 Example Mars Mission Analysis Results and Conclusions

The following are crew size recommendations based on the example Mars mission functional requirements analyses:

1. Vehicle construction in low Earth orbit – The construction crew size should be two with no EVA. Tasks such as inspections may always require EVA.
2. Earth / Mars transit operations – A small crew size (two or less) is best for transit operations. NASA should provide performance tasks to justify any larger crew. Recommended tasks include biological and physiological studies, Mars surface telerobotic exploration and preparation, cosmic phenomenon observations, and high quality communications for reporting observations.
3. Mars surface operations – Four crewmembers are best for Mars surface exploration. Planners should use robots and prefabricated structures for construction operations.

Crew size recommendations for specific designs are based on task requirements analyses using THURIS and task timelines. Following are the results:

1. Geodesic dome construction – The best construction crew size is four EVA crewmembers.
2. Mars vehicle aerobrake construction (Ames Central Core/Petal Design)- A crew size of three (one IVA and two EVA) is best.
3. Food production using salad machine design – Salad machine operation and maintenance have no impact on crew size.

The example analyses identified two questions regarding Mars missions that need resolution before crew size selection:

1. Identification of mission goals – The Mars mission goals (construction of a Mars base or exploration of Mars surface) significantly impact the optimum crew size.
2. Requirements for a Mars orbiting crew.

1.3.4.3 Computer Tools Survey Results and Conclusions

Many computer tools are available to aid human factors/human performance analyses. Of these the THURIS (The HUman Role In Space) tool appears most appropriate for selecting crew sizes for solar system exploration missions. The analyst can combine THURIS with task analyses to estimate the crew size to operate and maintain a specific design concept.

The following are recommendations for expanding the use of computer tools for human factors analysis and crew size studies:

1. **Cost Model** – Develop computer-based models to make cost-effective crew size decisions based solely on functional requirements. The program should support function analysis requirements tradeoffs discussed previously. Crew size selection requires cost estimates for launch, crew support, training, and technical development.
2. **THURIS** – Upgrade the cost and technology assumptions. A computerized version of THURIS was implemented on the Macintosh computer as part of this year's effort. Further development, however should be pursued to expand the analysis capabilities.
3. **Mission Requirements Database** – There should be a common mission requirements database for all Code Z activities. Triple-S software might be useful.
4. **Computer Tool Review and Selection** – The review, evaluation, and development of human performance analysis tools should be continued. The following are desirable qualities in a computer tool for human factors / human performance analysis:
 - a. **Flexible** – It should be easy to modify assumptions and compare results.
 - b. **Inexpensive** – It should be operable on a personal computer.

- c. Simple to Operate – Software should be operable by an analyst with little computer experience.
- d. Enduring – The computer program should be updated and maintained during the entire design and development process.

1.3.4.4 Design Guidelines

The example Mars mission analysis identified the need for human factors design information. As the solar system exploration program advances, designers and planners need detailed human factors design guidelines. Some human factors information is available in NASA-STD-3000, Man-System Integration Standards. The NASA standard primarily addresses microgravity and low Earth orbit environments. The standard does not address very long term missions or planetary environments. The human factors data should be expanded. More design guideline data can be developed through continued functional requirements analyses, task requirements analyses, and research studies. Designers and planners will need the following human factors design data:

1. Human load carrying limits in partial gravity conditions.
2. Probable human performance limits in future EVA suits.
3. Human factors design criteria for planetary habitats.
4. Data to help designers with trade-offs between humans and robots.
5. Human factors design criteria for artificial gravity living environments.
6. Medical problems and crew availability estimates on long term missions.
7. Living volume required for extended periods (both micro and partial gravity).
8. The effects of long term missions on psychological and social health and designs, procedures, and crew selection criteria to reduce any negative effects.

2.0 IN-SPACE OPERATIONS

Developments for in-space operations are presented in this section. In-space operations include such activities as construction of the space vehicle and aerobrake, hangar, docking and refueling, etc. General objectives of this study section are to:

- 1. Define the problem of in-space assembly such that automation, robotics and human performance aspects can be realistically examined.**
- 2. Select an assembly approach that makes effective use of automation and robotics.**
- 3. Define a reasonable mix of robotics and humans to perform the assembly tasks.**
- 4. Determine technology readiness.**
- 5. Identify issues for future work.**

Some specific objectives were:

- 1. Define hardware and operations systems capable of assembling the manned Mars vehicle in low Earth orbit.**
- 2. Minimize crew extra-vehicular activity (EVA).**
- 3. Assemble the vehicle systems in a sequence consistent with launch schedule for the components launched into orbit.**

2.1 DEPLOYABLE AEROBRAKE

Two general approaches for building an aerobrake in space were identified. One is to launch separate pieces of the aerobrake into orbit and assemble it there. Another is to launch into orbit the entire brake in a folded configuration. Once in orbit, the aerobrake would be deployed. The deployment can be completely automated.

The actual construction takes place on Earth where complete testing can be performed. This design takes advantage of the compressive forces during passage through an atmosphere to keep the aerobrake intact. . Figure 2-1 shows an aerobrake deploying inside of a construction hangar.

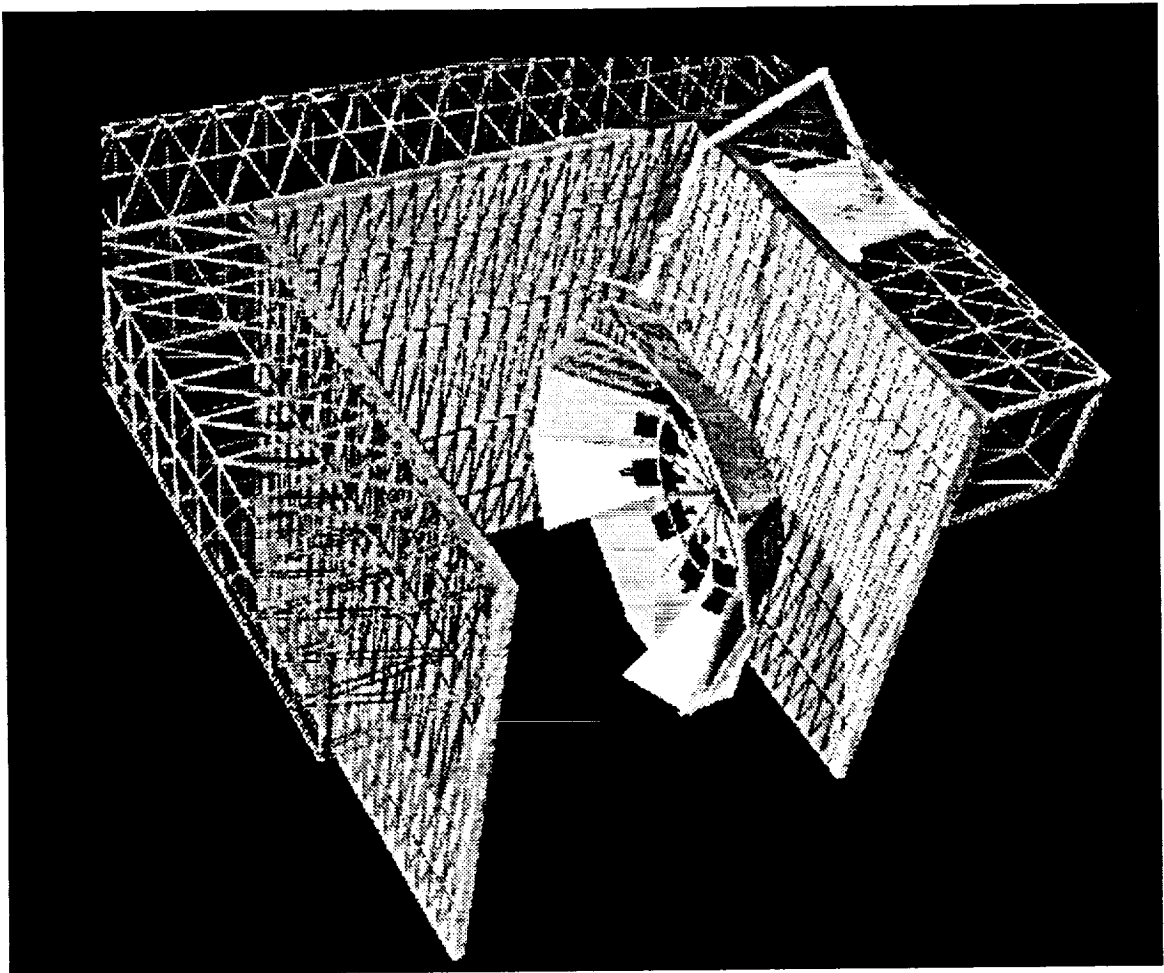

Figure 2-1. Deployable Symmetrical Aerobrake

2.2 IN-SPACE ASSEMBLY

General issues of assembly in space are discussed in this section. Included in this are assembly techniques and requirements for assembling spacecraft in orbit. Different assembly concepts for the spacecraft are also presented. One of the key developments presented is an idea for a versatile multi-purpose robotic vehicle (manned/unmanned) that can be used in space or on planet surfaces and can be operated in a variety of ways.

2.2.1 Intelligent Maneuvering Vehicle

The Intelligent Maneuvering Vehicle (IMV) is a very versatile mobile robotic vehicle. It is a modular, self-contained vehicle that can be operated in a manned or unmanned (teleoperated) mode (see Figure 2-2). Various modules can be attached to the bottom and sides of the basic unit.

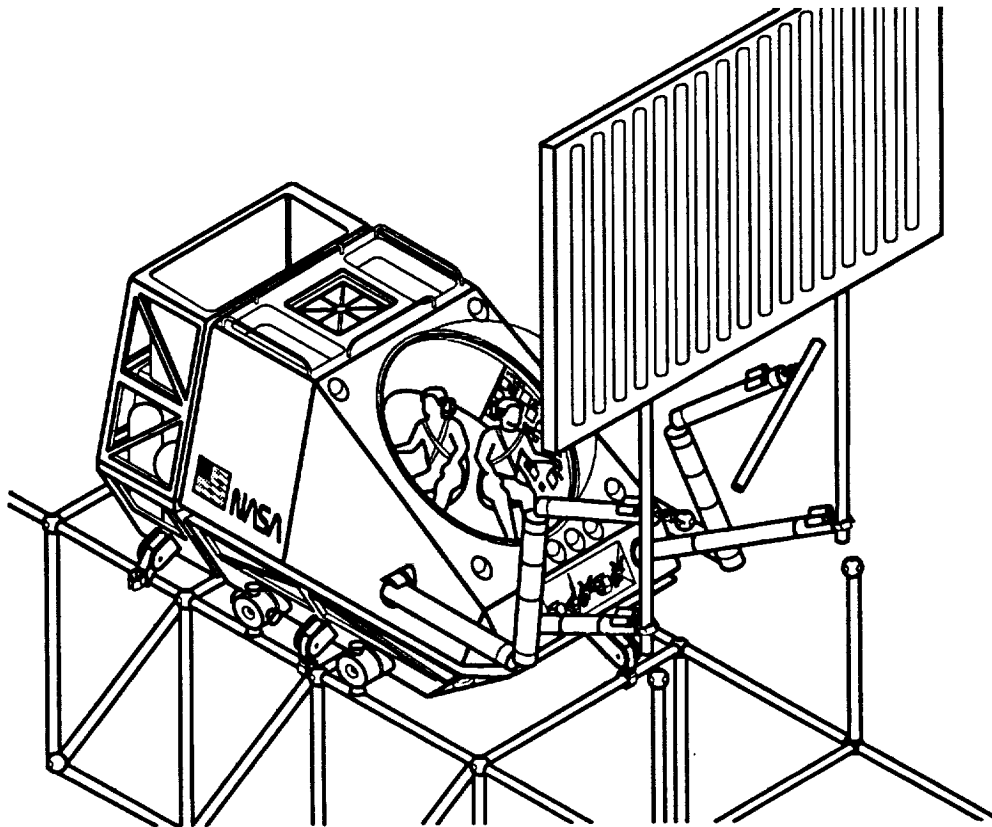

Figure 2-2 . Intelligent Maneuvering Vehicle

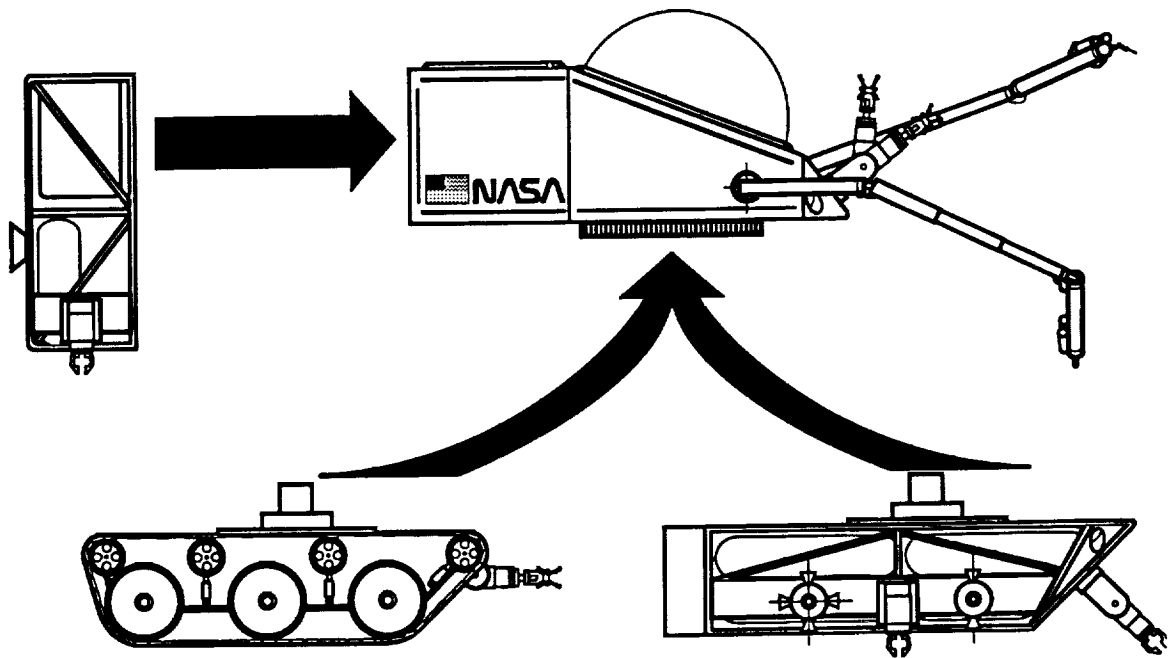

Figure 2-3. IMV Modules

Figure 2-3 shows an exploded view of the IMV and some of its modules. These modules contain propellant, thrusters and manipulators. Different modules allow the IMV to operate on planet surfaces. This is discussed in the planetary operations section.

Nine manipulator arms extend from the vehicle with the bottom module included. These arms are for:

1. Anchoring of the IMV to a truss or other structure (eg. tanks).
2. Manipulation and positioning of large or small structures.
3. Assembly of complex structures.

Different types of end effectors are used depending on the type of arm and operation. Heavy duty effectors are used on the lower arms for anchoring the IMV. The four arms extending from the front of the vehicle are light duty and have a whole suite of end effectors. Figure 2-4 shows one of the arms, its degrees of freedom and some of the possible end effectors. Included in this suite are grippers and welding tools.

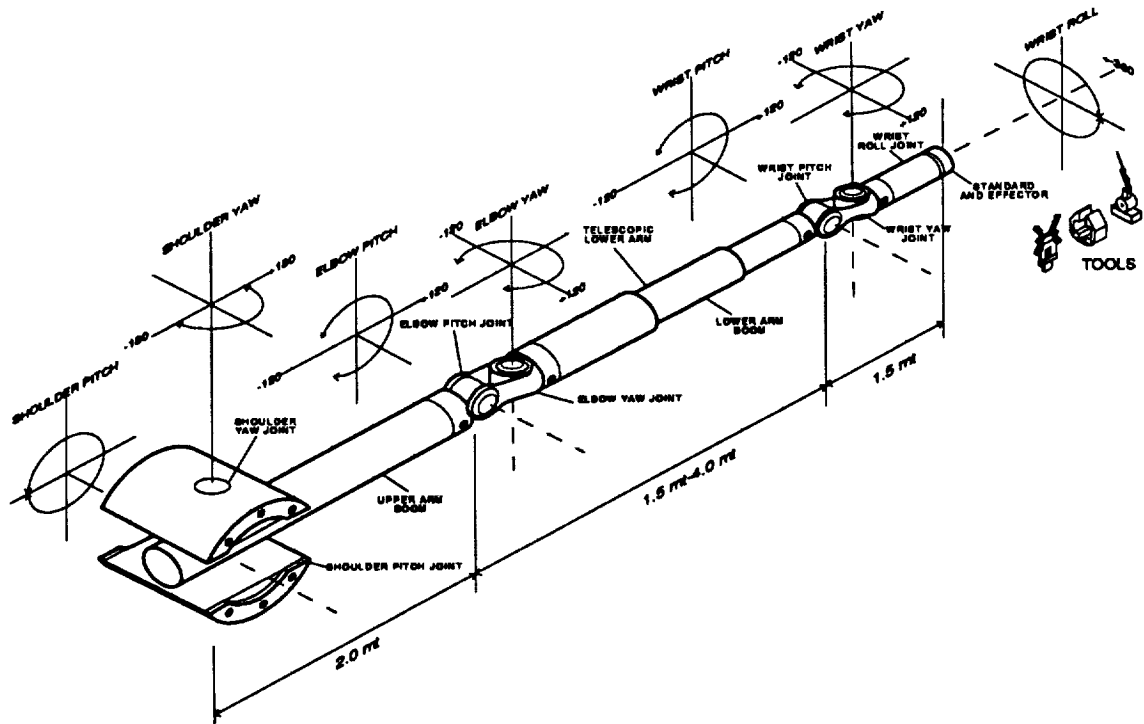

Figure 2-4 IMV Manipulator Arm

The system utilizes mature effector and sensor technology for control of the robotic limbs. Several video cameras are mounted on the IMV to aid in monitoring remote operations. Embedded fish-eye CCD sensors provide vision capabilities to end effectors.

2.2.2 Spacecraft Assembly

Two basic scenarios have been developed for assembling a spacecraft in orbit. The first is to use a hanger to hold the ship in place during construction. Another concept envisioned by Boeing uses the exploration vehicle's aerobrake as its own assembly platform. The spacecraft is free flying the entire time except for initial aerobrake construction.

2.2.2.1 In Hangar Spacecraft Assembly

The first item assembled is the aerobrake. The assembly of the support structures is next. The manipulator places the segments together one at a time to be joined. The manipulator may be any one or combination of several possibilities. They include the IMV, RMS arms, flight telerobotic servicer (FTS) or astronaut EVA. For the manned Mars vehicles the crew habitat is assembled next and then secured onto the aerobrake. The structural rings and propellant tanks are then joined to the vehicle. Finally, the propulsion system is attached. Figure 2-5 shows this sequence.

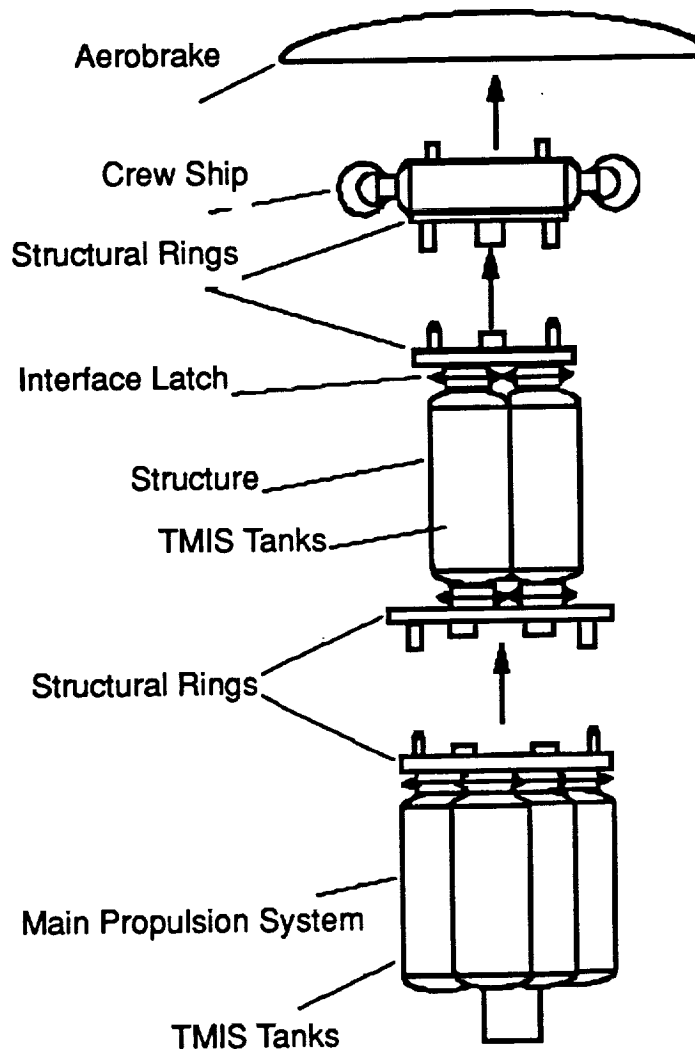

Figure 2-5. Spacecraft Assembly Sequence

2.2.2.2 Free Flying Spacecraft Assembly

In the Boeing concept the need for a construction hangar is eliminated. The aerobrake is the initial element of the ship to be constructed. It is assembled at the Space Station using any of the manipulators mentioned above. It is then equipped with assembly equipment and support services such as RMS or FTS to continue the construction.

The initial construction stage is illustrated in Figure 2-6. The platform is then released from the Space Station into a free orbit. Construction continues using the equipment mounted on the aerobrake. Two RMS arms on a rail system that runs around the rim of the aerobrake work together to construct the rest of the spacecraft.

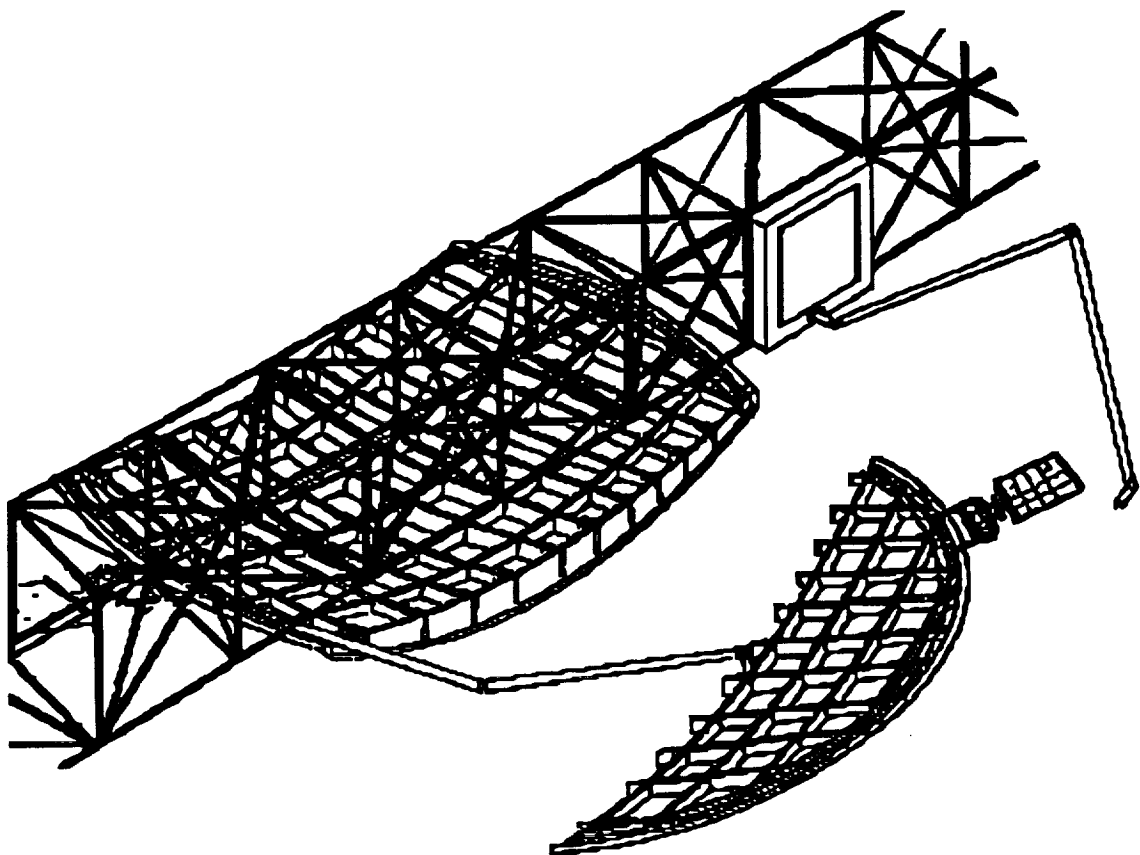

Figure 2-6. Assembly of the Aerobrake at Space Station

2.2.3 Assembly Techniques

The first section of this report touched on four ways of joining components to each other. They are:

1. Bolting
2. Pinning and Bolting
3. Welding
4. Module Interfaces

The last one is for joining habitat modules together. An analogous type of interface can be used for joining propellant tanks. Figure 2-7 illustrates the first three techniques. These techniques also apply to assembly on planetary surfaces.

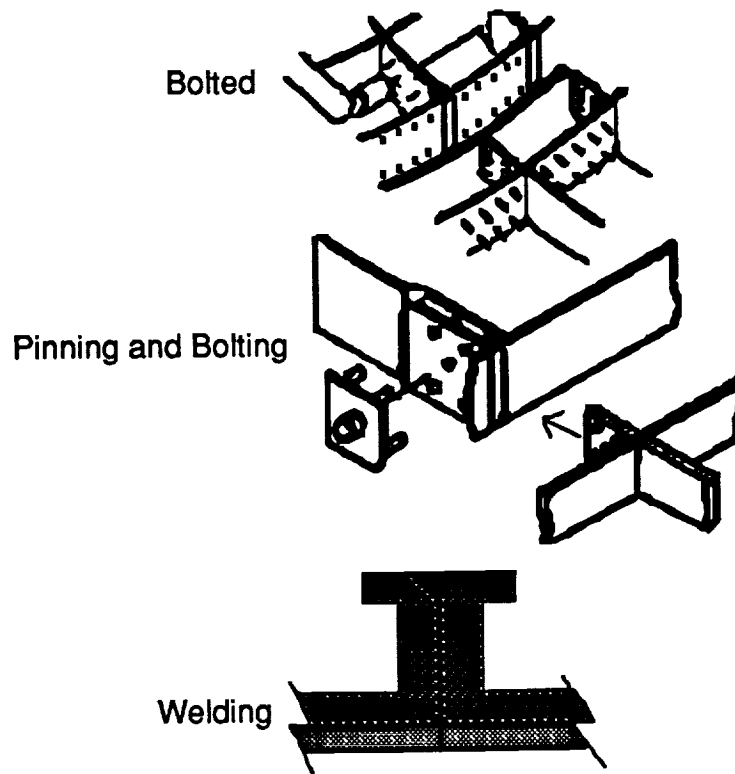

Figure 2-7. Joining Methods

All of the methods of joining require positioning accuracy and torque capability from the manipulator. The components must be designed with lead-in tapers to accept positioning errors and bolts must be captive. The sensing equipment on robotic arms should include video cameras to allow direct monitoring of activities and small fisheye CCD sensors to provide machine vision. All hardware is tagged with bar codes for positive identification. The end effectors are also equipped with 6-axis EM antennas so that the controller can determine the position and orientation of the end effector.

2.2.4 Assembly Operations Analysis

The roles and functions of the assembly flight crew in-orbit are:

1. Receive, guide, position and maneuver vehicle elements via teleoperator, OMV, RF link and EVA for processing and positioning.
2. Supervise and monitor automated assembly equipment and perform manual operations as needed.
3. Monitor test and checkout sequences, respond to ground test conductor commands, observe system response and report system performances and anomalies.
4. Perform EVA as necessary to observe and direct external movements, quality inspect, troubleshoot and repair/replace faulty components in the vehicle elements or orbital servicing equipment.

Correspondingly, the ground test and checkout crew also has certain roles and functions:

1. Conduct test and checkout via data link between test center and on-orbit assembly site.
2. Direct flight crew in movement and assembly of vehicle elements.
3. Identify malfunctioning equipment, resolve anomalies and decide on corrective action.
4. Monitor and control health of assembled elements awaiting vehicle integration.

5. Monitor and control health of assembly infrastructure.
6. Verify readiness of vehicles and certify them for launch to Mars.

2.3 HANDLING LARGE STRUCTURES

Handling large structures in space can be very difficult because the object to be moved is often more massive than the manipulator. This means that the momentum of the object needs to be considered and the problem now has 12 degrees of freedom (see path planning).

Many construction concepts use an RMS arm on a mobile base to do the construction. The mobile base is attached to the Space Station structure or to a vehicle hangar structure. An FTS may or may not be attached to the end of the arm. The free flying IMV also assists in the construction in either manned or unmanned mode. A later section discusses a Fairchild assembly concept very similar to the above concepts but using an enhanced version of the FTS.

Arms of the robotic assembly suite need to span the entire work space. Hold-down grapples to secure the front ends to special fixtures should also be considered. This stabilizes the arms so that they perform precise motions more easily.

2.4 AUTOMATED RENDEZVOUS & DOCKING

It is important that docking be soft to reduce loads and transient vibration on internal equipment. Once docked, the arms or whatever connecting mechanism should be very rigid to reduce dynamic complications (including control problems) of two large fluid filled tanks.

A concept was developed that automatically docks two propellant tanks so that the energy of impact is absorbed. Figure 2-8 shows an exploded view of a design for the rendezvous and docking mechanism. It consists of modular docking rings, thruster packs, far and near field sensors, robotic manipulators and a latching device. The tanks are brought into far field sensing range by the thrusters. The manipulator arms on one tank reach for and grab the docking ring on the other tank as it approaches near-field sensing range. The manipulators then provide final guidance and bring the two tanks into contact. They also provide kinetic energy damping.

Thrusting needs to be allowed even as the two tanks get very close so that the arms do not have to catch a fast and heavy object. Docking procedures can be developed so that reaction mass from the thrusters does not impinge on any structure.

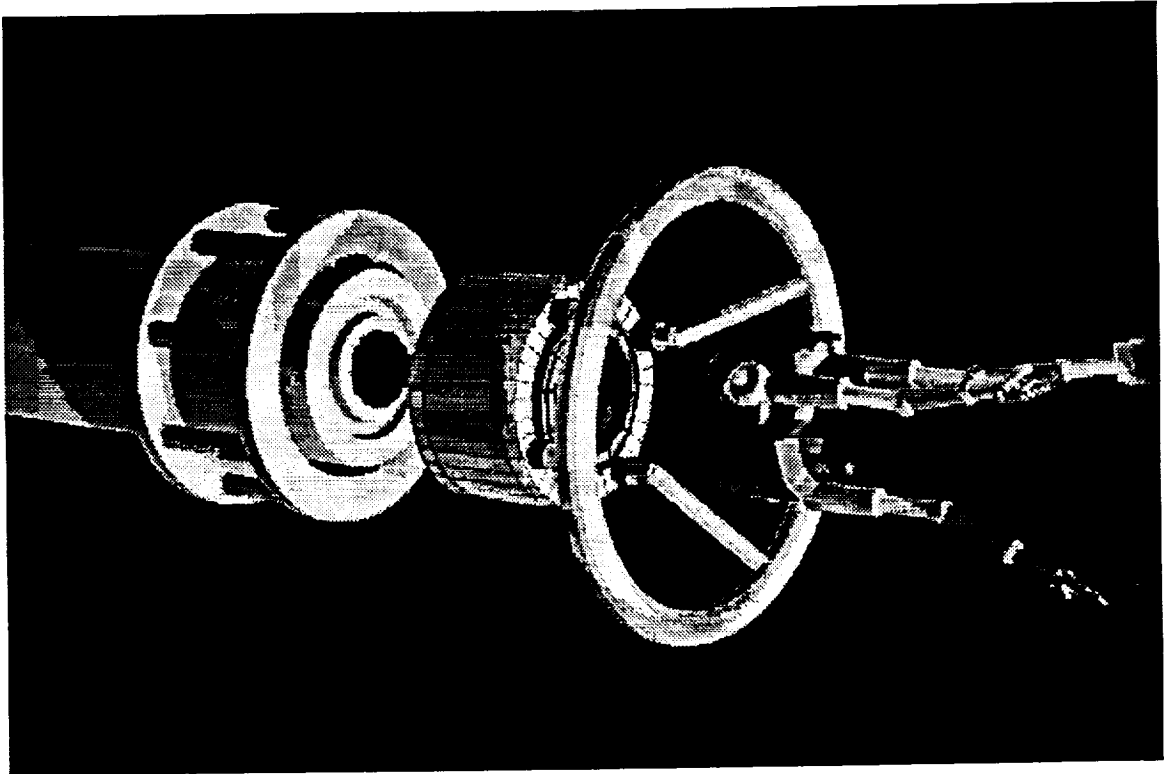

Figure 2-8. Automated Rendezvous and Docking Mechanism

Far-field guidance is provided by a television system and laser radar. Near field guidance is provided by electromagnetic coils. Guidance forces are provided by thruster packs until the robotic arms can attach to the approaching tank. The latching mechanism provides further energy dissipation as the two tanks are brought into contact. See figures 2-10 and 2-11. The rendezvous and docking is completely automated.

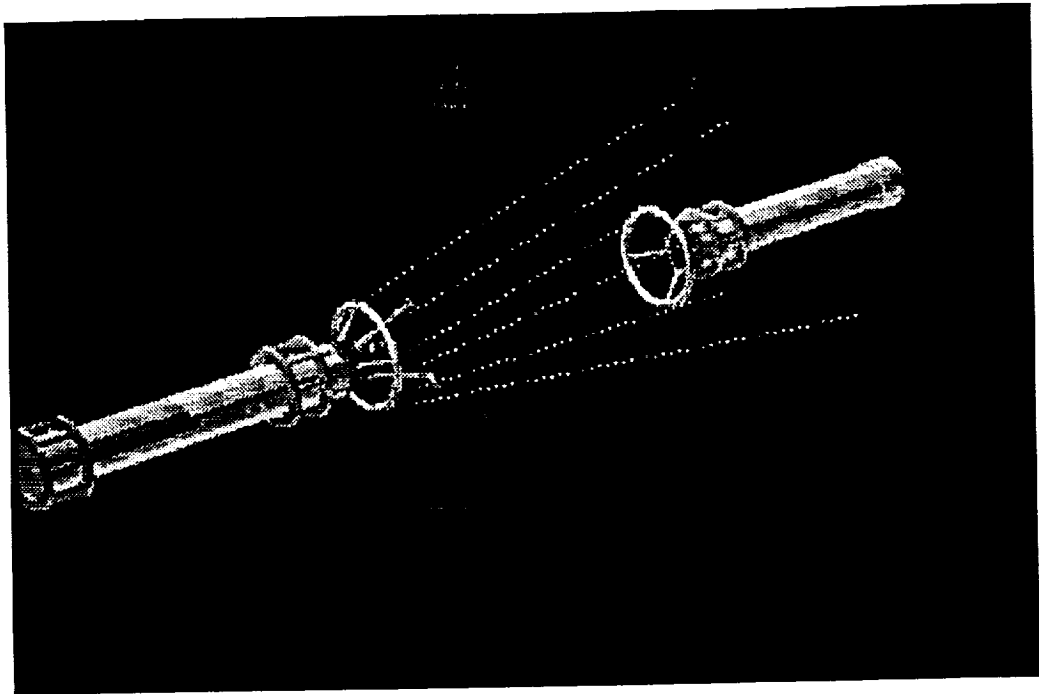

Figure 2-9 . Sensors and Robotic Arms for Rendezvous

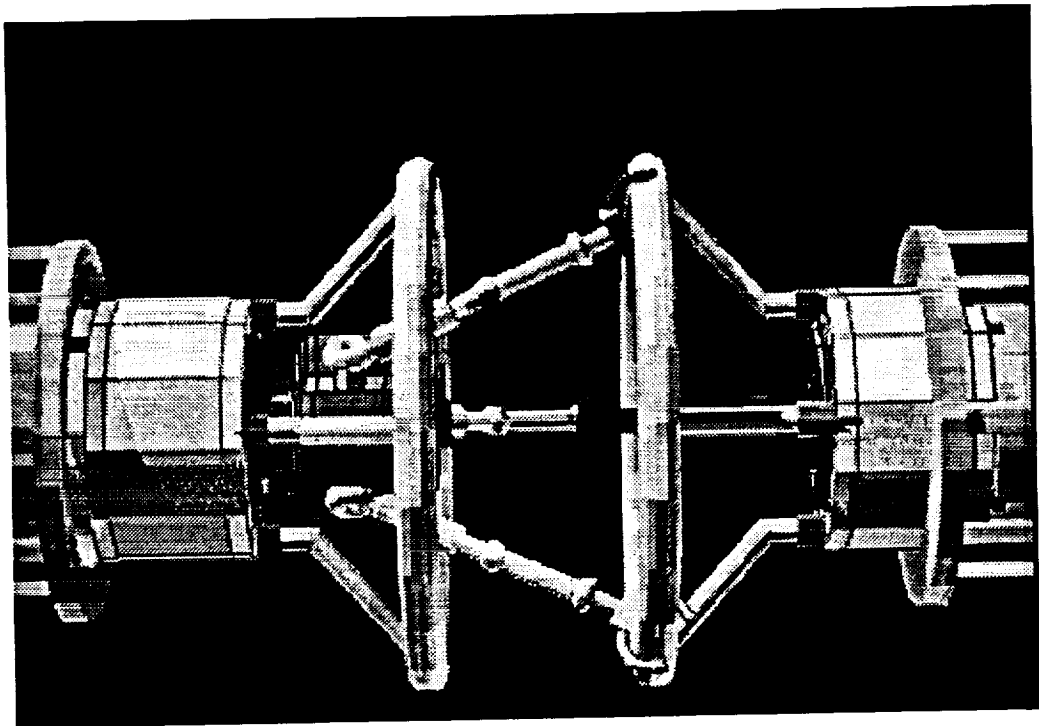

Figure 2-10. Final Docking with Energy Dissipation and Storage

The docking is considered "soft" by dissipation of the kinetic energy. Kinetic energy is converted into potential energy in the springs and electrical energy in magnetic coils.

Because the components of the docking mechanism are modular, they can easily be taken off of one tank and mounted on another. The IMV is shown doing that in Figure 2-11.

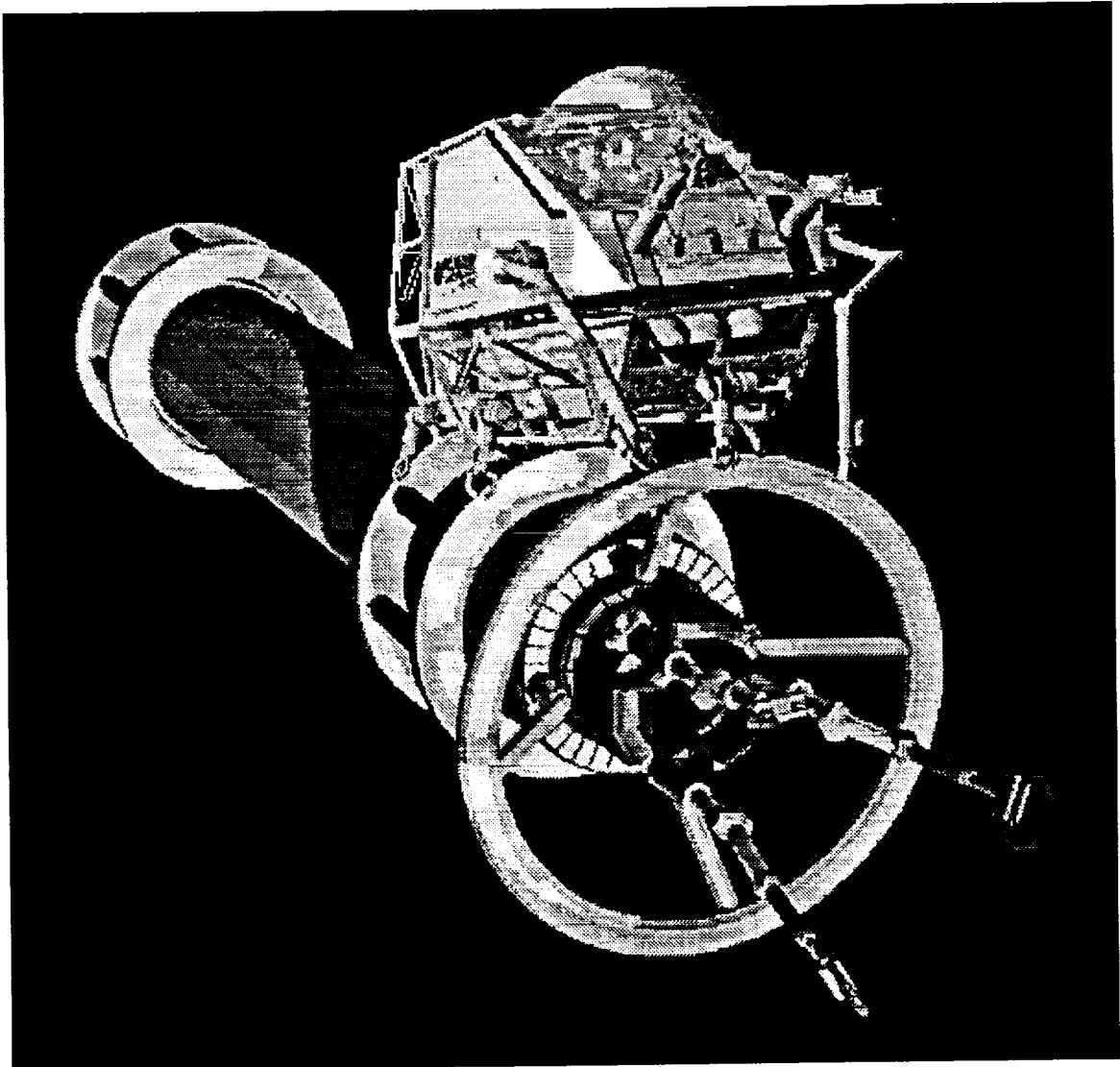

Figure 2-11. IMV Attaching Docking Mechanism to Tank

2.5 PROPELLANT TRANSFER & HANDLING

2.5.1 Propellant Transfer

Propellant needs to be transferred after the tanks are docked. Fuel transfer is a problem because uncontrollable voids develop as a pressurized tank drains into another. These voids can prevent further pumping. See Figure 2-12.

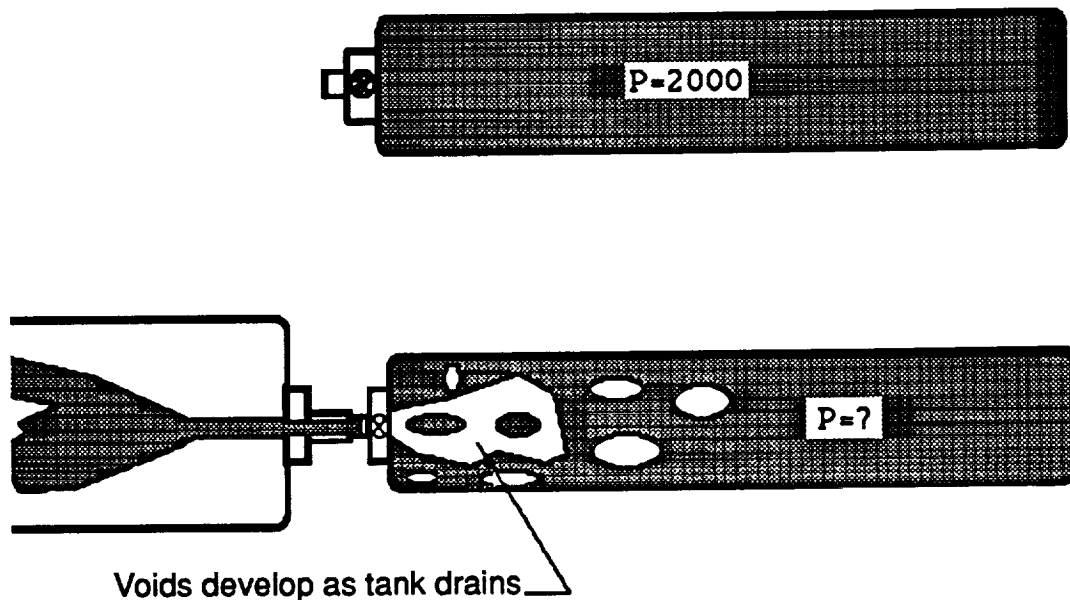

Figure 2-12. Voids Develop In Pressurized Tank

A proposed solution is to use an Archimedes screw to force the fluid out. The screw and its bearing are sealed in the tank and coupled to a motor with a magnetic coupler through the rear end. The screw also acts as a fluid baffle when not used to empty a tank. This concept is illustrated in Figure 2-13.

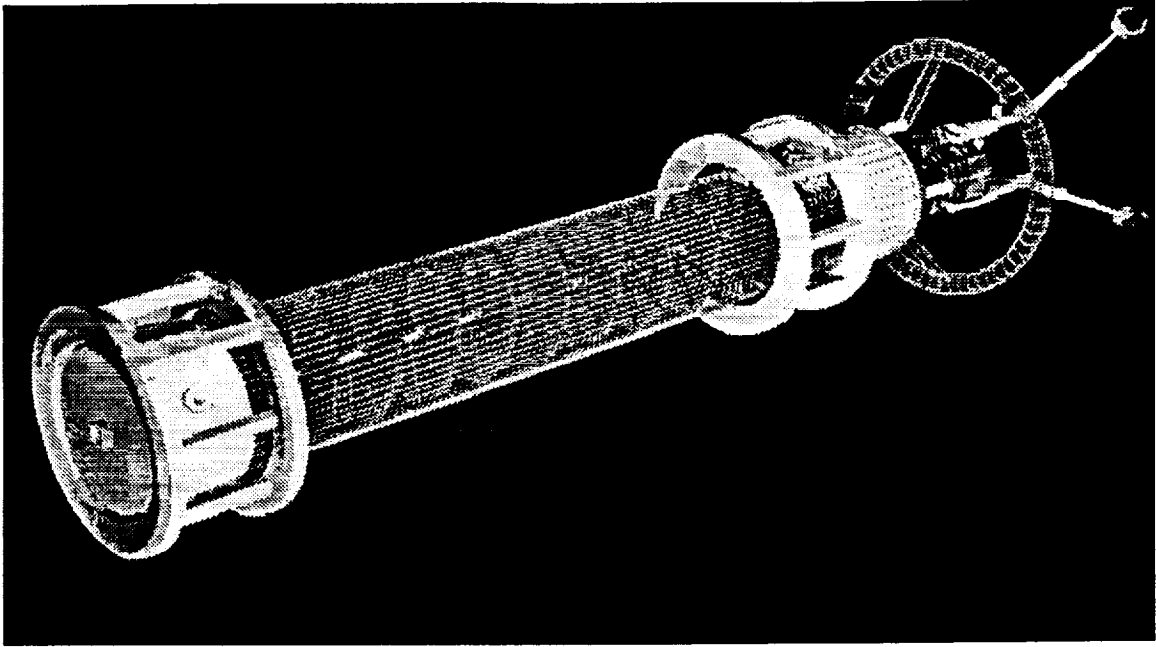

Figure 2-13. Tank with Internal Archimedes Screw

A similar concept uses rotating vanes to force the fluid to the outside and then up through the valves. This concept also uses a magnetic coupling to operate the vanes.

Another possibility is to rotate the entire tank and have fluid drawn from the outer radius of the tank. A despin docking collar and rotary fluid coupling would be needed for this method.

2.5.2 Helical Tanker

The helical fuel tanker is a system that handles many small tanks instead of one big one. The tanker is docked with empty tanks aboard the spacecraft using techniques described above. The tanker then uses a mechanism to rotate each full tank into line with the empty tank. A fueling line is connected and the empty tank is filled with propellant. Each of the small tanks in the tanker will need an internal pumping device as described above. When the small tank is emptied the tanker rotates it out of the way and brings a full one into line. The mechanism is much like the feed mechanism on a gatling gun, only using propellant tanks. Figure 2-14 shows the tanker docked with the spacecraft to be refueled .

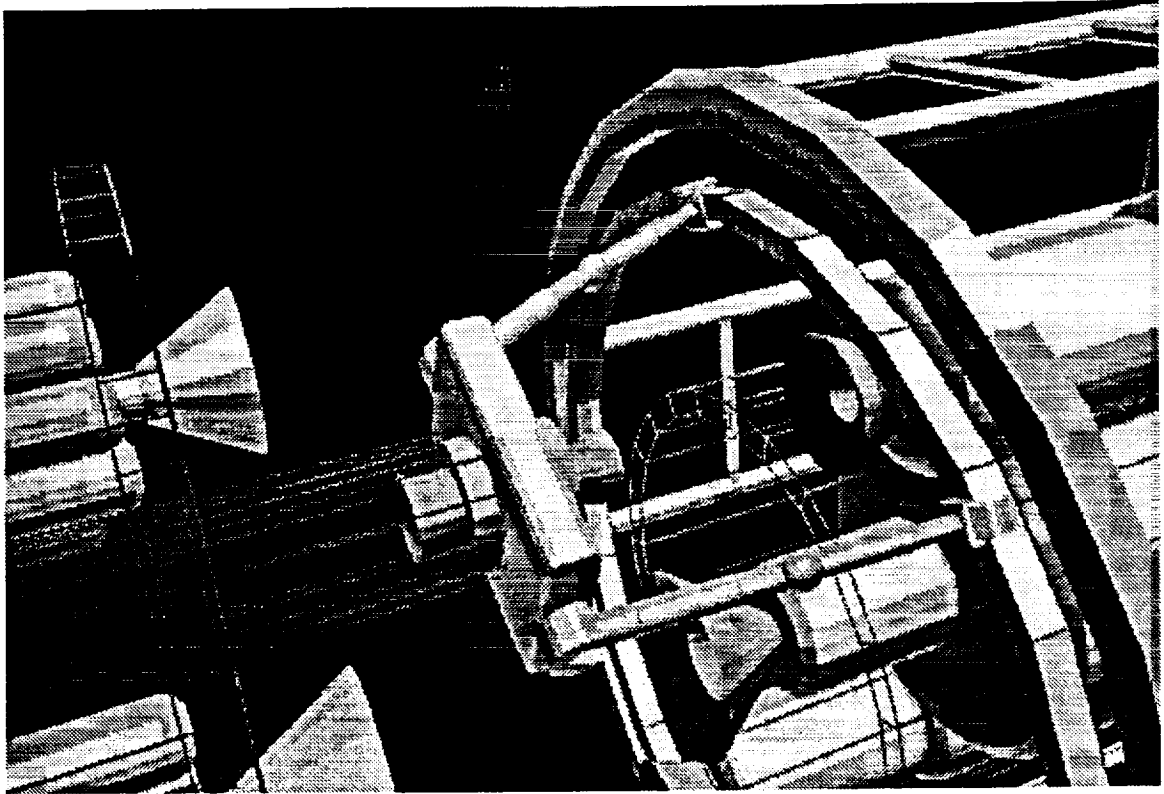

Figure 2-14. Helical Tanker Refueling Tanks Aboard Spacecraft

2.6 ENHANCED FTS

The flight telerobotic servicer (FTS) is a small robot that has some of the abilities of the IMV. It can operate independently or be moved about by an RMS arm. A modified version of the FTS is used for planetary surface operations. This is discussed later in the report.

2.6.1 Requirements

Some of the tasks identified for the FTS are:

1. Assembly and servicing of the transportation vehicle at the Space Station.
2. Rendezvous, docking and fluid transfer operations involving transportation vehicle fuel tanks.

A later section on the FTS describes the assembly of a construction hanger using the FTS. In general, the FTS should be capable of:

1. Teleoperation/telerobotic operation by one person at work station.
2. Fixed-based operation with wireless communication.
3. Mobile-based operation using the OMV as the base.
4. Semi-autonomous operation.

Specific requirements on some of the subsystems include:

- Control algorithms.
- Capability to handle flexible structures.
- Capability to perform tasks in disturbance environment (mechanical vibrations).
- Adaptive control capability to handle a wide range of structural masses.
- Cooperative multi-arm control.
- Bilateral force reflection control for better operator feel during low force, dexterous operations.
- Force/torque control for dexterous manipulation of objects.

Vision System

The vision system should provide the following three viewing modes: a global view, task overview and a close up view for detailed operation and inspection. At least four cameras are needed to provide this vision. One camera is placed on or near the wrist of each arm and two others are positionable for specific worksite viewing. Color video, stereo video, and proper lighting should be provided.

Robotic Manipulators

Multisensory information from the end effectors is needed to perform dexterous operations. Sensors are needed at each joint to measure torques, positions and rates required for telerobotic control. For safety reasons a joint braking system is also needed to override the joint torques.

2.6.2 Transportation Vehicle Assembly

It is assumed that all the components are modularized and provided with interfaces for robotic assembly. The FTS combined with the IMV will provide the necessary capabilities required to assemble, monitor and repair complex space systems.

2.6.3 Rendezvous and Docking

The FTS can be used to assist tank rendezvous and docking operations. However, there are some concerns:

1. The FTS arm link joints may require stiffing to accomplish docking within structural margins of safety.
2. Some of FTS systems that are sensitive to remote and extended operation will require modification.
3. OMV attitude control systems must be capable of accommodating the forces produced by grappling and docking the fuel tank.
4. A tool kit should be provided to facilitate FTS dexterous servicing operation.
5. The OMV must provide a special foot restraint for the FTS.
6. The OMV control system must be capable of handling the FTS/OMV combined configuration.

2.6.4 FTS Conclusions

Some conclusions concerning using FTS for assembling the transportation vehicles can be made. In some cases, they are nearly identical to general assembly conclusions above.

1. FTS can be used as configured for on-orbit assembly operations.
2. A transport vehicle is required for maneuvering the FTS about the worksite.
3. Rigid supports are required to secure spacecraft components in position during assembly.
4. Spacecraft components must be modularized and designs standardized as much as possible.
5. Component interfaces must be designed to be compatible with teleoperated robotic operations.
6. Components that need to be handled by FTS must have handling fixtures.
7. Close up and overview video should be provided.
8. If welding is chosen as the joining method, guidance along the joints is required.

2.7 ON-ORBIT MAINTENANCE AND REPAIR

The commonality of parts reduces spares requirements. It is important to have as much commonality as possible in the design process to ease the spares problem. System designs should allow for low-level replacement, and should allow for robotic removal and replacement where practical.

An effective large-scale expert system for maintenance (FDIR) will be required. This may be the most demanding aspect of the automation.

In the Boeing assembly concept, the construction manipulators are mounted on the aerobrake and can be stored during transit to Mars. They can be deployed and used to perform maintenance and repair tasks.

2.8 ADVANCED ENGINEERING SOFTWARE

2.8.1 Requirements

Advanced software techniques will be required to control, in an integrated fashion, the following subsystems:

1. Guidance, navigation and control (GN&C)
2. Environmental control and life support
3. Electrical power generation and distribution
4. Thermal control
5. Propellant management
6. Reactive control
7. Data management
8. Communications
9. Avionics.

Advanced software techniques will also be required to handle multisensory information coming from these systems and from sensors monitoring structural integrity and performance.

The application of Advanced Engineering (AES) techniques to specific in-space operations is discussed next.

2.8.2 In-Space Assembly

Supervised robotic assembly is used for the bulk of the assembly work. This is supported by planned and contingency EVA when necessary and appropriate. Human control is supervisory through hierarchical autonomy. This way, people can make full use of available machine intelligence while still retaining the option of assembling components using primitive commands.

Two generic software modules are needed for in-space operations. An expert system is needed to control and monitor the assembly process. This includes step by step procedures for telepresence operations and contingency operations. A real-time procedural software system module is also needed. This module performs the telepresence and robotic operations.

An additional requirement is that the expert system perform checkout and testing operations. This system process information is used to perform structural integrity checkout and performance monitoring throughout the mission. It interprets sensor and built-in test equipment (BITE) data for fault detection, isolation and reconfiguration or recovery (FDIR).

The procedural module in Table I shows the principle levels of capability of automation and robotics assumed and rationales for selection of those levels.

The computational structure required to accomplish effective robotic orbital assembly consists of hierarchical loops which link intentions to physical reality through action taken and data sensed. Figure 2-15 shows a diagram of this architecture. The most detailed loop generates basic machine commands and receives raw sensor data. The response occurs at millisecond rates. Automated control is reflexive and processed at the tool level. Human intervention is required at this level (via teleoperation) as well as joystick control.

The next higher loop issues tactical machine operation commands to be executed by the basic level. This is done by working with symbolic representation of the physical data from which features have been extracted. The response at this level is on the order of seconds. Automated control is symbolically interactive and processed at the manipulator arm root for example. Human intervention at this level is supervisory.

The highest loop develops a strategic task script for machine execution based on a semantic domain model of the object being assembled. Task generation occurs on the order of minutes and the processing can occur remotely. Human intervention consists of preprogramming or changing the script template rules.

Operations with Man-in-the-loop is a necessary provision in the design and development process. Man-in-the-loop must always be available as a means of problem solving because not all eventualities can be foreseen.

A well developed system and software for FDIR is needed. However, artificial intelligence schemes are not necessarily needed. FDIR can be facilitated by a mature and well tested expert system.

ITEM/LEVEL	RATIONALE FOR NEED	RATIONALE FOR ATTAINABILITY	SPECIAL SENSORS OR EFFECTORS
Automated rendezvous and soft docking (thrust, grapple, latch, fasten)	<ul style="list-style-type: none"> • Assemble propulsion stages away from Space Station • Achieve dependable gentle docking • Reduce assembly time 	<ul style="list-style-type: none"> • Soviets do it • Straightforward problem with adequate sensors • Several candidate proven technologies 	<ul style="list-style-type: none"> • RF range & range rate 100km to 100m • Laser radar or robotic vision range, angles, rates & relative attitude 100m to contact
Position parts and assemblies for attachment or installation; remove and install components and "black boxes"	<ul style="list-style-type: none"> • Assembled spacecraft are too large for launch shroud; assy. on orbit required • Positioning requirements exceed human EVA capability • Necessary to remove & replace faulty equipment 	<ul style="list-style-type: none"> • Merely requires adding some automation to Shuttle RMS capability • Hardware can be designed to simplify robotics task 	<ul style="list-style-type: none"> • Grapple which controls or senses relative attitude of arm end and part/assembly • Means of sensing relative positions of attach points and receptacles • Force sensing & control • Design parts for simple remove/replace motions • Arm end fixing
Install fasteners in programmed locations	<ul style="list-style-type: none"> • Minimize EVA • 24-hr operation • Avoid joystick mode (slow with time delay, inaccurate) • Multiple visits 	<ul style="list-style-type: none"> • Routinely done by Earth-based robotics; pattern bolting is common factory automation 	<ul style="list-style-type: none"> • Relative position sensing • Positive identification of fastener holes • Force sensing & control • Arm end fixing
Torque or otherwise secure fasteners; actuate latches and other mechanisms	<ul style="list-style-type: none"> • Same as above • Controlled torque needed for structural quality control • Hardware installation and removal 	<ul style="list-style-type: none"> • Simple task 	<ul style="list-style-type: none"> • Torque sensing or analog • Arm end fixing • Suitable end effectors
Aerobrake sealant application	<ul style="list-style-type: none"> • Consistent, thorough coverage • Reduce time • No hand-holds on large brake front surface 	<ul style="list-style-type: none"> • Existing manufacturing robot application 	<ul style="list-style-type: none"> • Proximity sensing • Special tool & material delivery systems • Seam tracker • Force sensing & control

Table I. Automation & Robotics Capabilities

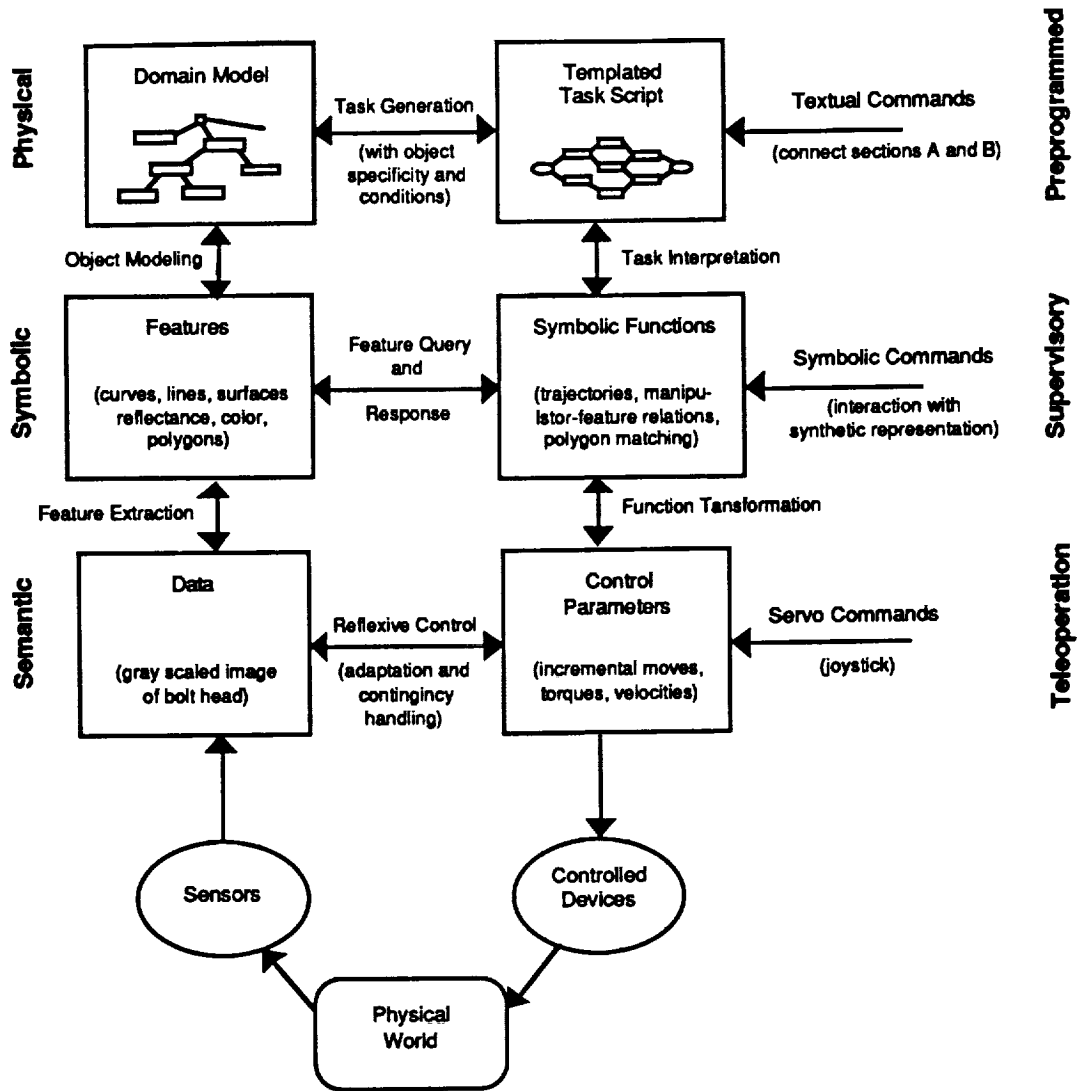

Figure 2-15. In-Space Assembly AES Architecture

2.8.3 Automated Docking with Robotic Arms

The real-time procedural software system would be required to:

1. Process CCD video data for identification and guidance to docking target.
2. Identify hazardous conditions.

3. Provide GN&C for docking operations (LIDAR/near field EM guidance).
4. Update criticality level for docking process based on estimated time till docking.
5. Broadcast warnings based on criticality level.

2.8.4 Propellant Transfer in zero G

A feedback control system is needed for internal screw velocity (assumes Archimedian screw concept). The control is based on sensor data of void development inside the propellant tank. A second requirement is for trend data analysis of void developments by procedural software to increase smooth propellant transfer.

2.8.5 Mars Orbiting Vehicle AES

Mars Orbiting Vehicle (MOV) autonomy is necessary due to communications constraints. AES can reduce the dangers of the communications barriers by providing several vital functions including:

1. Vehicle subsystem Fault Detection, Isolation and Reconfiguration (FDIR).
2. Real-time mission support for contingency operations.

Rule-based expert systems might be too inflexible to support the required autonomy. A flexible decision support and FDIR Advanced Engineering Software (AES) system may require implementing a hybrid software approach integrating procedural, expert system, model-based diagnostic and reactive planning software technologies.

Figure 2-16 depicts the high-level view of a concept for an embedded on-board AES architecture for the Mars orbiting vehicle (MOV). The Vehicle Manager program is the central hub of the system. Figure 2-17 shows more detail of the Vehicle Control and FDIR architecture.

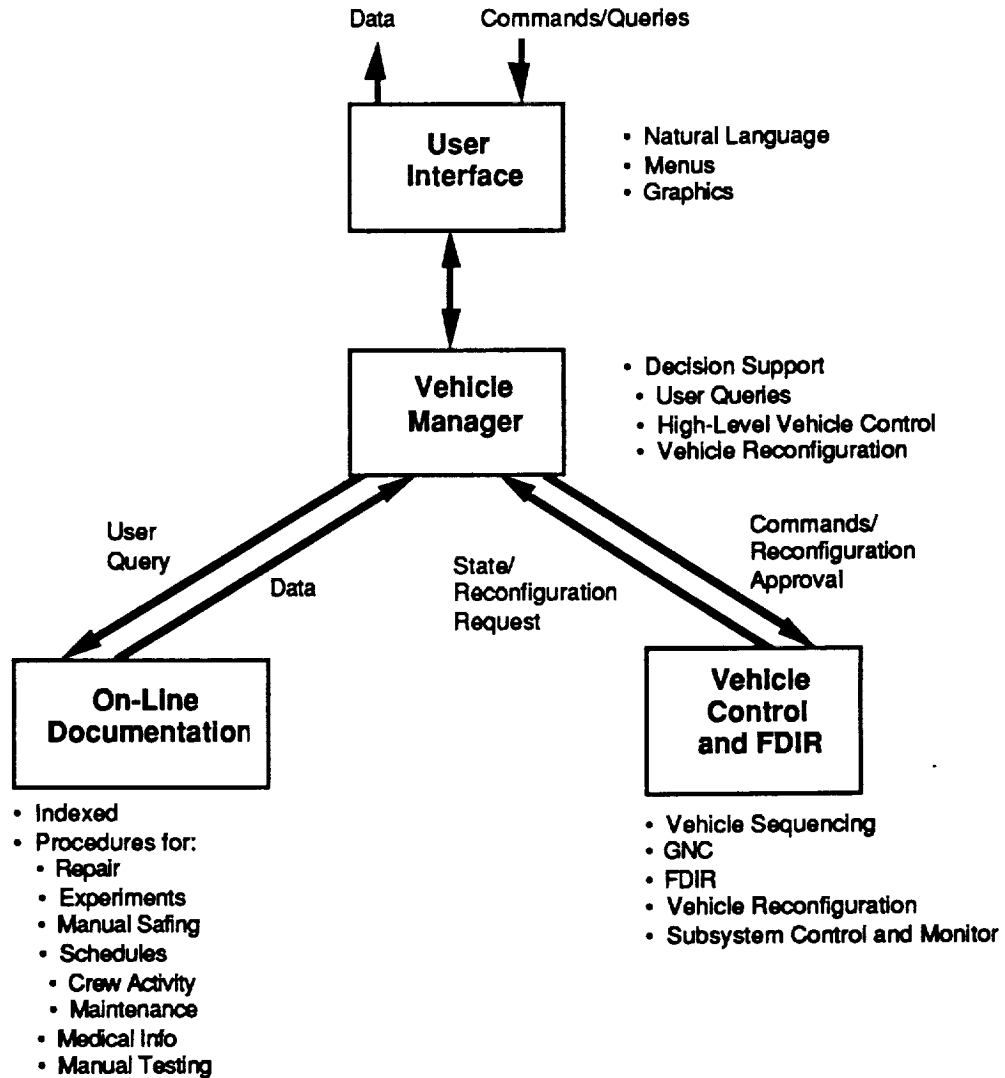

Figure 2-16. MOV on-Board AES Architecture

The probability of hardware failures will be greater than those experienced currently due to the extended duration of the Mars mission. The design of a MOV management system architecture should therefore consider redundancy and safety as well as efficient execution. The data management system hardware architecture shown in Figure 2-19 should increase system reliability through dynamic allocation of software programs. A failed processor's software could be reallocated to another processor. A decrease in cost and complexity is obtained through use of standardized hardware processors.

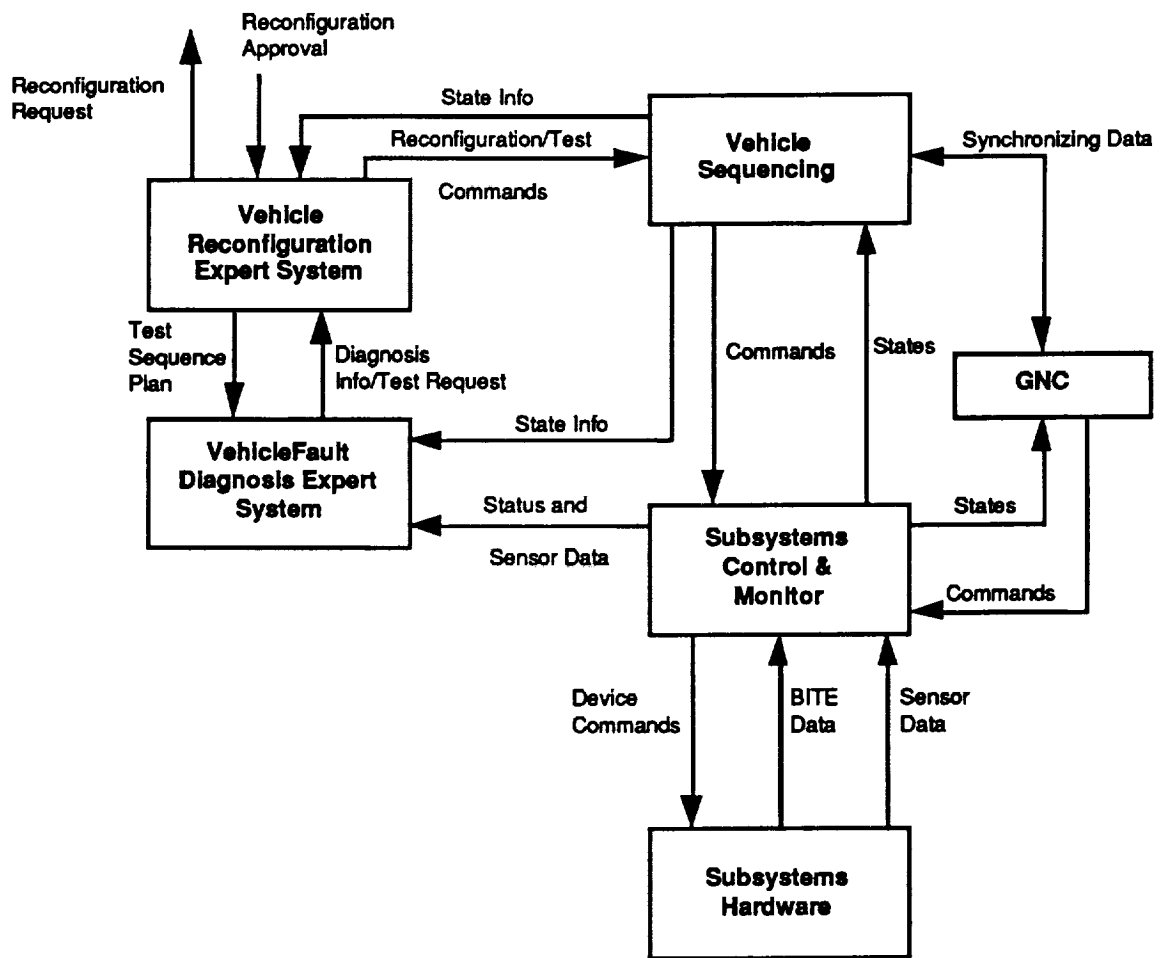

Figure 2-17. Vehicle Control and FDIR Architecture

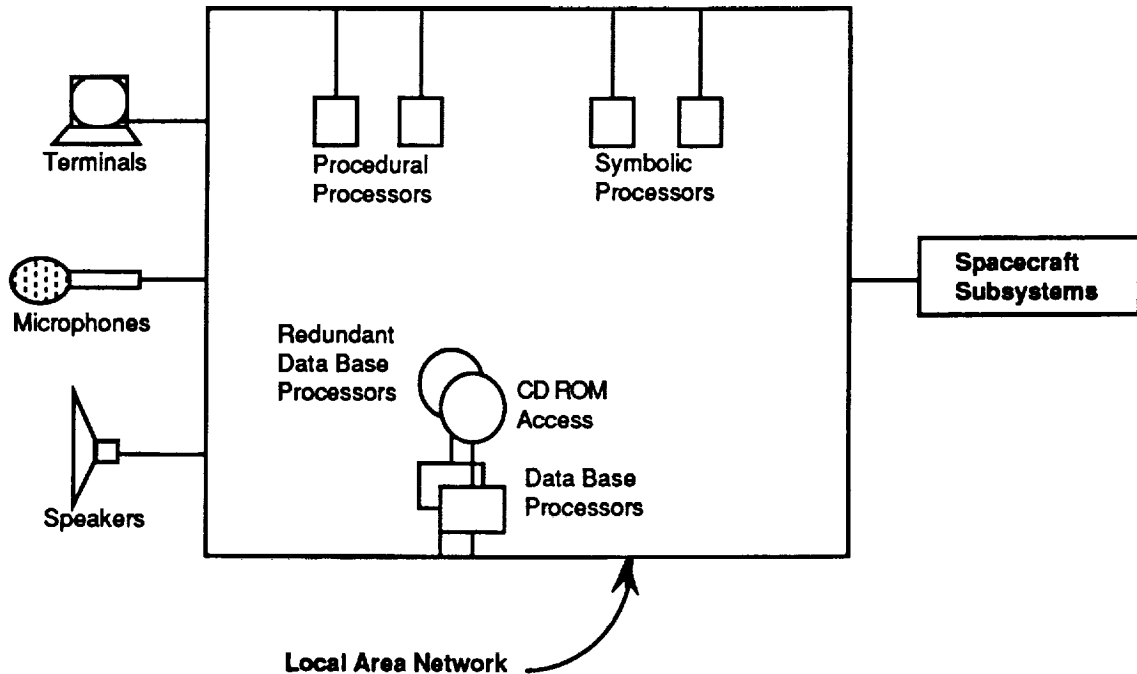

Figure 2-18. MOV Data Management System Hardware Architecture

2.9 DEPLOYMENT/CONTROL, ARTIFICIAL GRAVITY

Russian experience shows that very long periods in micro-gravity environment leaves an astronaut a virtual cripple for a time after return to a one G environment. This is despite a vigorous exercise program. For this reason, it might be worthwhile to provide artificial gravity despite its added complications.

One concept uses two habitat modules on cables. The cables can be reeled in and out to provide one G at their maximum length. A rotation rate of 4 rpm will provide one G at a radius of 55 meters. Figure 2-19 shows the modules being deployed. Each habitat has three cables attached to it to minimize oscillation and to increase stability in the deployed configuration.

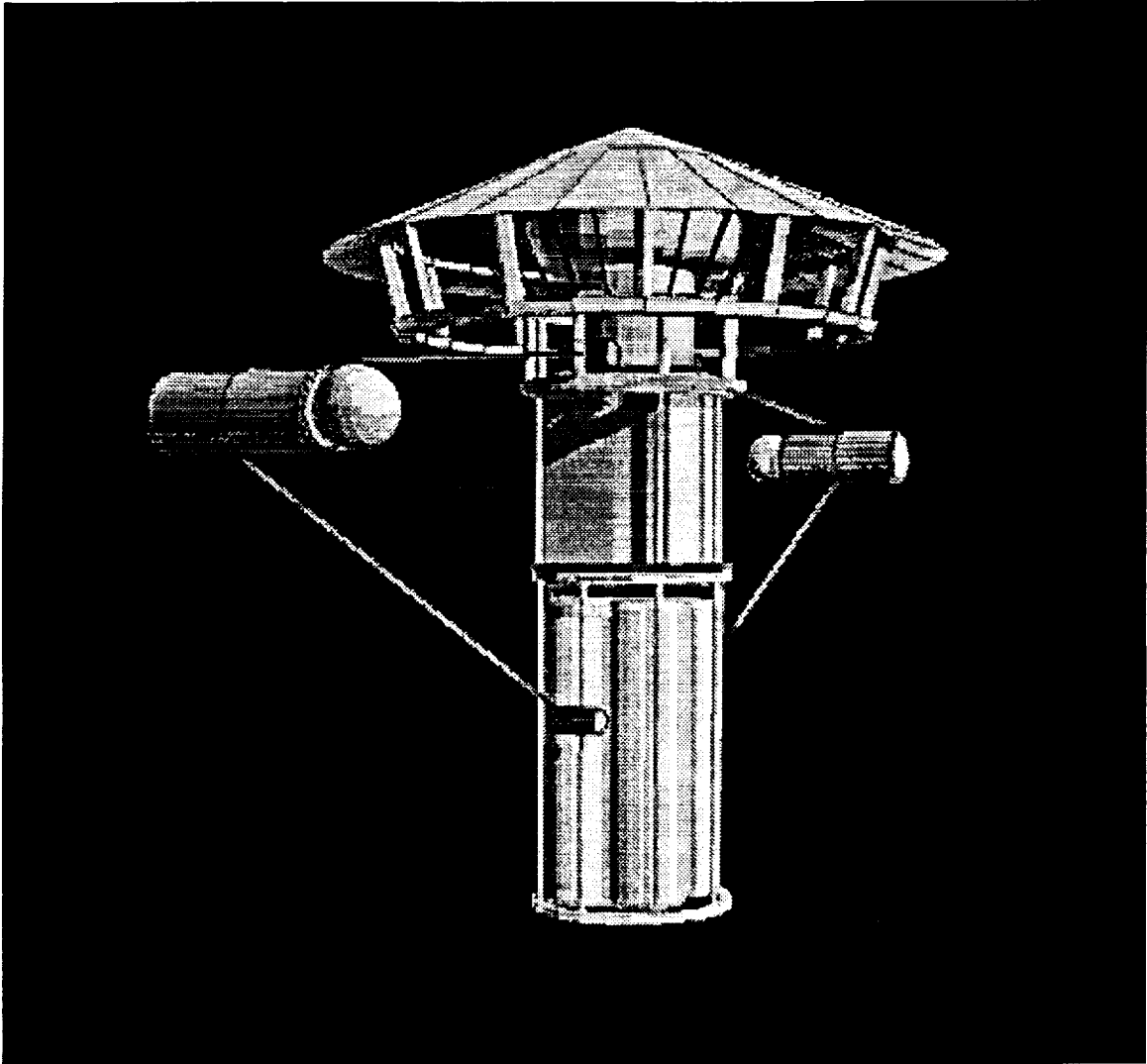

Figure 2-19. Manned Spacecraft Deploys Artificial Gravity Modules

An automated mass balance system is used to counteract mass movements within the habitat modules and the associated vehicle subsystems. An expert system is required to manage imbalances created by propellant consumption. Expert systems also provide automated control of gravity spin rate and control of habitat modules subsystems.

2.10 CONCLUSIONS

Orbital assembly of space vehicles require advanced automation techniques and robotic techniques. It is necessary that the vehicles are designed for robotic assembly.

Representative advanced robotics technologies that are required are:

- 1. Preprogrammed repetitive task performance primitives such as installation of fasteners, welding, seaming, etc. .**
- 2. Sensors and software techniques to enable automated location in and navigation about the workplace.**
- 3. Machine vision and various identification approaches to enable the robots to positively identify work points.**
- 4. Hierarchical, flexible software to enable humans to interact with robots at a high man-machine level.**
- 5. Integrated system and software approaches for fault detection, isolation and recovery.**

3.0 PLANETARY SURFACE OPERATIONS

This section is devoted to operations that will occur on planetary surfaces. Developments for Automation & Robotics are presented as well as considerations for the planning of an outpost.

3.1 PLANNING

The tasks for planning an outpost are listed below:

1. Identify the function of an initial outpost.
2. Define necessary base elements and site plan.
3. Determine the construction and operations requirements.
4. Determine the sequence of construction and operations.
5. Define the robotic operations and equipment.
6. Determine the supporting manifests.
7. Determine crew/automation roles.
8. Estimate equipment failure rates and work arounds.

3.1.1 Functions

One of the primary functions of an initial outpost on the Moon would be for the mining and production of oxygen. The oxygen extracted from mined ore would be used as propellant. Some of the oxygen would also be used to make up the habitat atmosphere.

3.1.2 Outpost Elements

The outpost elements that are required can be divided into one of four categories.

1. Primary elements.
2. Mobile robots.
3. Utilities.
4. Siteworks.

3.1.2.1 Primary Elements

Primary elements for the outpost include such items as the lander, habitat, radiation shielding for the habitat, power system, mining facilities and oxygen extraction and storage facilities. These are discussed in more detail later.

3.1.2.2 Mobile Robots

Mobile robots will perform heavy work and transportation duties. A large crane vehicle will be utilized for lifting, moving and positioning of heavy objects. It would also be used to support mining operations. A medium duty "truck" would perform tasks such as grading, foundation excavation, remote repairs and towing. A light duty rover would be used for initial site surveys and would be converted for use as a manned rover. A planetary surface version of the IMV would be used to perform the duties of both the medium and light duty robots. An enhanced FTS could be utilized to perform some of the light duties.

Figure 3-1 shows some of the modules that can be configured for the surface version of the IMV. The modules give the vehicle all-terrain mobility, towing, high-reach and automated construction capabilities.

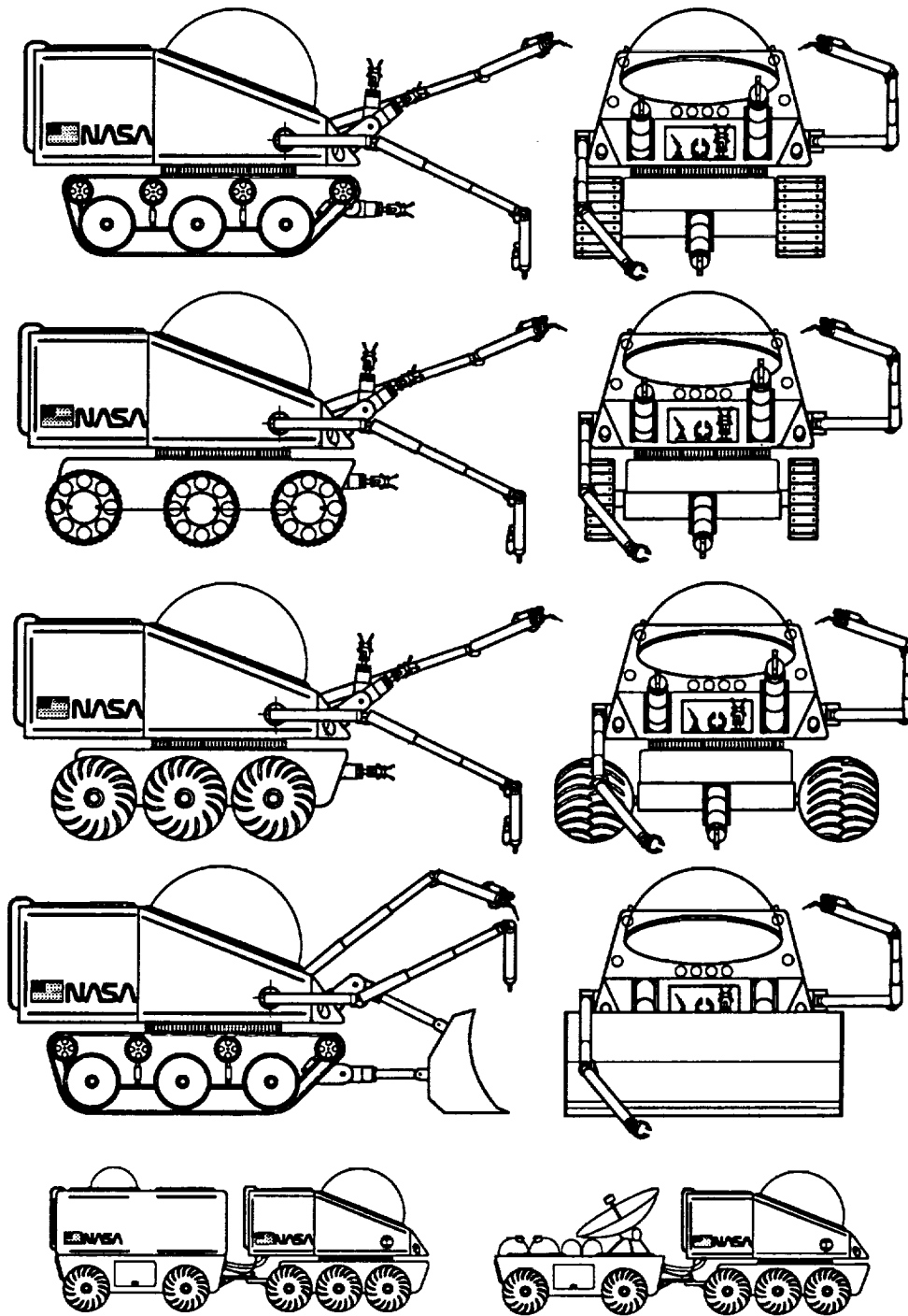

Figure 3-1. Planetary Modules for the IMV

3.1.2.3 Utilities

Utilities include many parts of the base infrastructure. Such things as guidance beacons, communications transceivers, local lights, conduits or piping etc. are included.

3.1.2.4 Siteworks

The outpost should have the same number of landing pads as the number of landers. Each pad should have a prepared surface. The foundations for the structures can be undisturbed regolith with the top meter scraped off. A paved open work yard is needed for equipment staging, disassembly and reconfiguration. Sites are needed to deposit rocks and spent oxygen-reactor solids. Finally, prepared roads are needed to connect the whole site together. See the outpost Site Plan in the Boeing report "Robotic Lunar Surface Operations" for a possible site plan.

3.2 LANDING SITE

3.2.1 Initial Preparation

An initial precursor flight is needed for site survey. Two light rovers (for redundancy) are landed at the site equipped with site survey packages. They will carry and deploy guidance beacons for the cargo vehicle landings.

The initial cargo flights will be unmanned and telerobotic site preparation and construction is required. This includes autonomous construction of the solar arrays, habitat/workshop, LOX plant and landing pads. The checkout, testing and repair capabilities will also be required.

3.2.2 Automated Landing Operations

An autonomous landing system will be required. Figure 3-2 depicts how the wide-field system locates the approaching spacecraft. The final descent and near-field guidance system is illustrated utilizing a millimeter radar system in Figure 3-3.

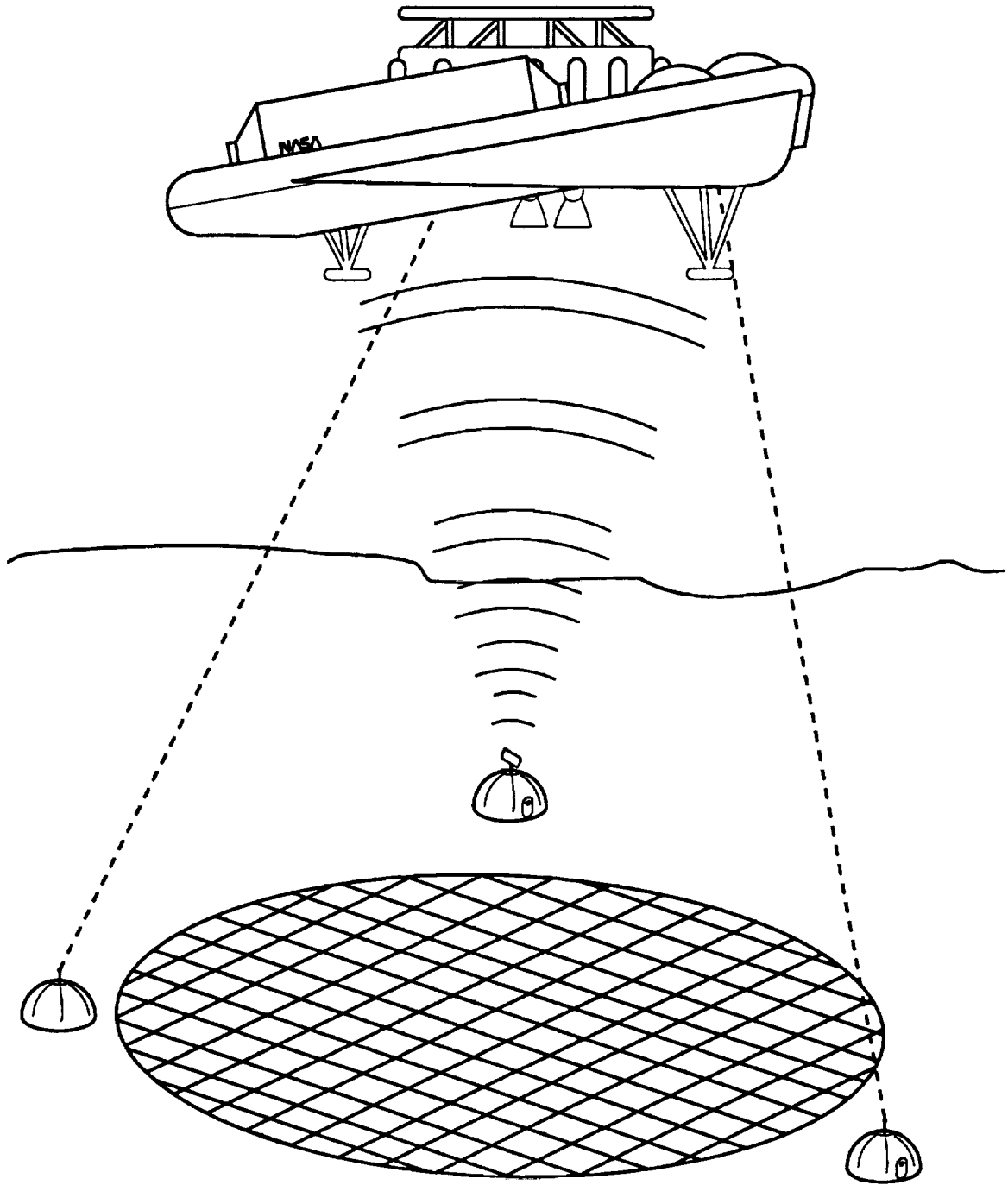

Figure 3-2. Wide-field Landing System

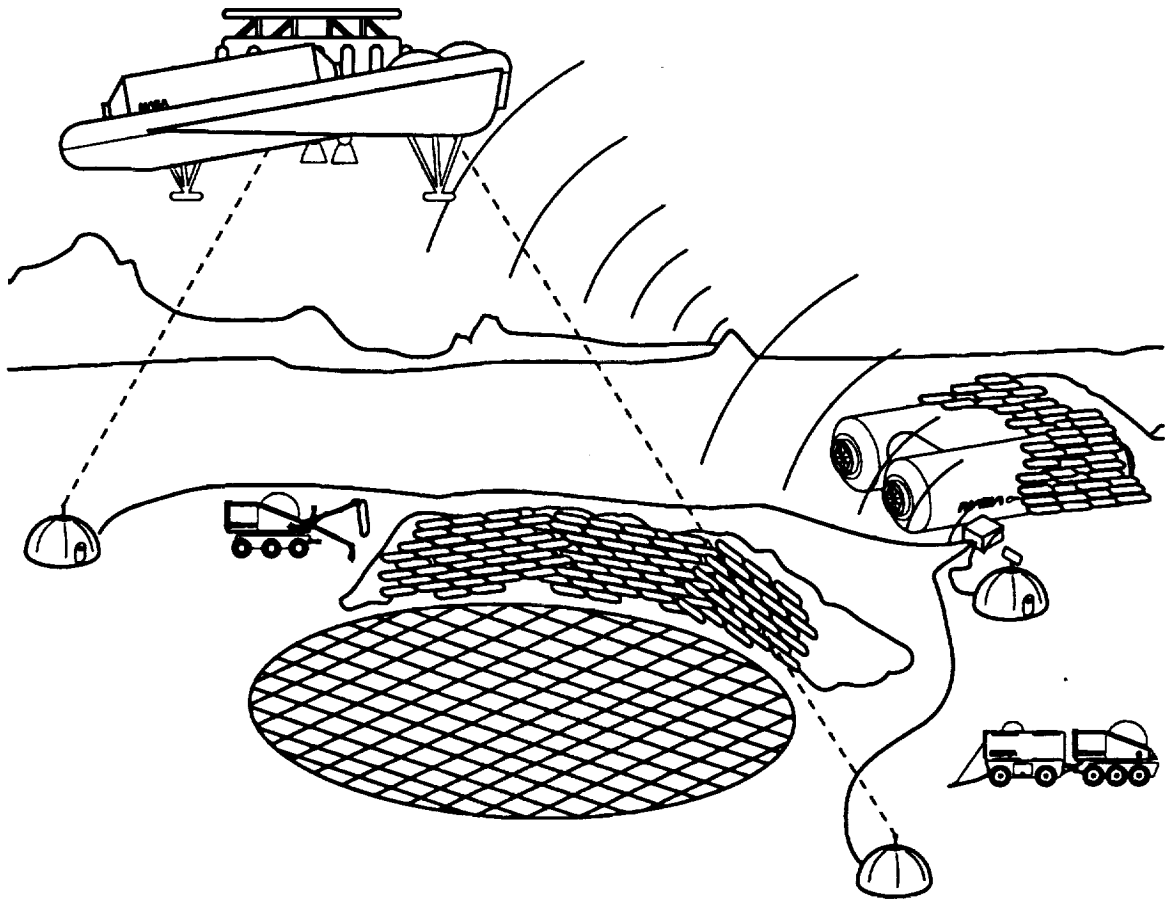

Figure 3-3. Near-field Landing System Used for Final Descent

The unloading of the spacecraft after landing is accomplished with the assistance of onboard cargo handling equipment and equipment on the surface (including the IMV). An unloading operation using the IMV is shown in Figure 3-4.

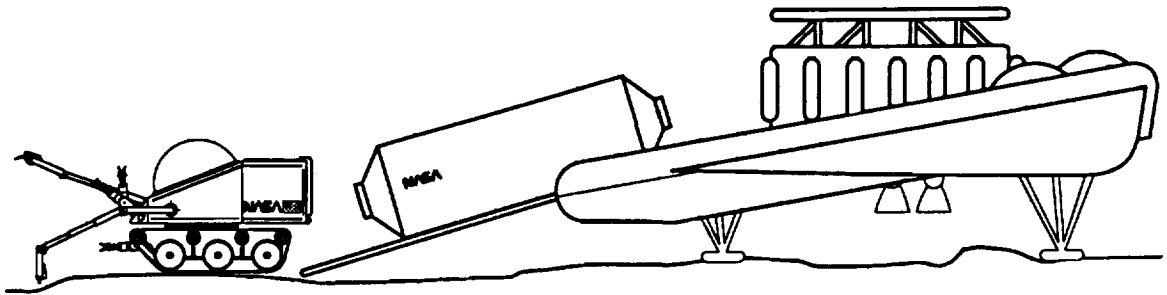

Figure 3-4. Unloading Space Station Modules

3.3 PROPELLANT PRODUCTION

Spacecraft vehicle weight can be saved by providing propellants at the destinations. Propellant production begins with the mining ore from the surface and the processing of the ore to extract the propellant.

3.3.1 Surface Mining

In addition to supporting the production of propellant, mining operations are required for:

1. Producing shielding material for the human habitat.
2. Excavating the site where the habitat modules will be emplaced.
3. Geological assay of the surface.

The first step in surface mining is to determine the mineral richness of the proposed site. Core samples will be required. The mining process consists of:

1. Removal of overburden.
2. Break-up of the ore.
3. Transport of the ore to the processing plant.
4. Processing of the ore into propellant and by-products.

There are several techniques that were developed for implementing the operations listed above. They range from bucket wheel diggers with conveyer belts to digging vehicles with shovels and ore transporting vehicles. Another approach uses intelligent communicating diggers and carts on tracks to enable semi-autonomous operation. Another alternative is to use a boring technique. Similar in concept to tunnel construction on Earth.

3.3.1.1 Digging and Transport Vehicles

Both Boeing and Fairchild proposed concepts for digging vehicles and ore transport vehicles. Refer to those reports for details of the concepts.

The large crane proposed by Boeing holds the mining tool. In this approach ore is collected and taken to the processing facility. The Fairchild concept is a mobile mining tool.

3.3.1.2 Intelligent Communicating Carts

This approach provides fail-safe capabilities. Multiple carts and repair capabilities are provided.

A proposed alternative is a set of intelligent carts on tracks. A very limited form of intelligent communicating agent architecture is utilized. In this approach, serious problems can be solved by a human supervisor via a teleoperated robot (eg. the IMV). See the later section on finite-state machine architecture.

In this concept, carts and diggers are on a separate set of tracks and operate independently. The carts carry bins into which the ore and waste are loaded by the diggers. When the cart arrives, the digger changes empty bins for full ones. The cart then moves back down the track toward the main track where it switches bins with a main track cart. The main track cart brings the ore to the processing facility. The system can be sized to operate for a year in this manner before retracking is needed.

A robotic boring machine was developed for mining into hillsides. A disk cutter is utilized for boring out the front face and sweeper arms are used to move the crushed rock back to conveyer belts. The belts move the ore to transporter vehicles or directly to the processing plant.

3.3.2 Processing Facility

The processing facility extracts oxygen from the ore and liquefy it for later use. The facility is also utilized to produce useful by-products from the extraction waste. A useful application of by-products includes habitat shielding or using the brick material for the landing pad.

A solar powered oxygen extraction concept was developed which uses mirrors to concentrate sunlight on the reactor oven at the top of the facility. A heat exchanger and preheater is used to increase the efficiency of the process.

3.4 PLANETARY SURFACE HABITAT

A range of habitat concepts were developed. The crew size and the level of automation and robotics required for each concept vary widely. (*See Crew Size Study Report* on details for a geodesic structure).

3.4.1 Domes

Figure 3-5 illustrates the deployable dome habitat concept that was developed. This concept is transportable and requires minimal crew size and robotics to set up.

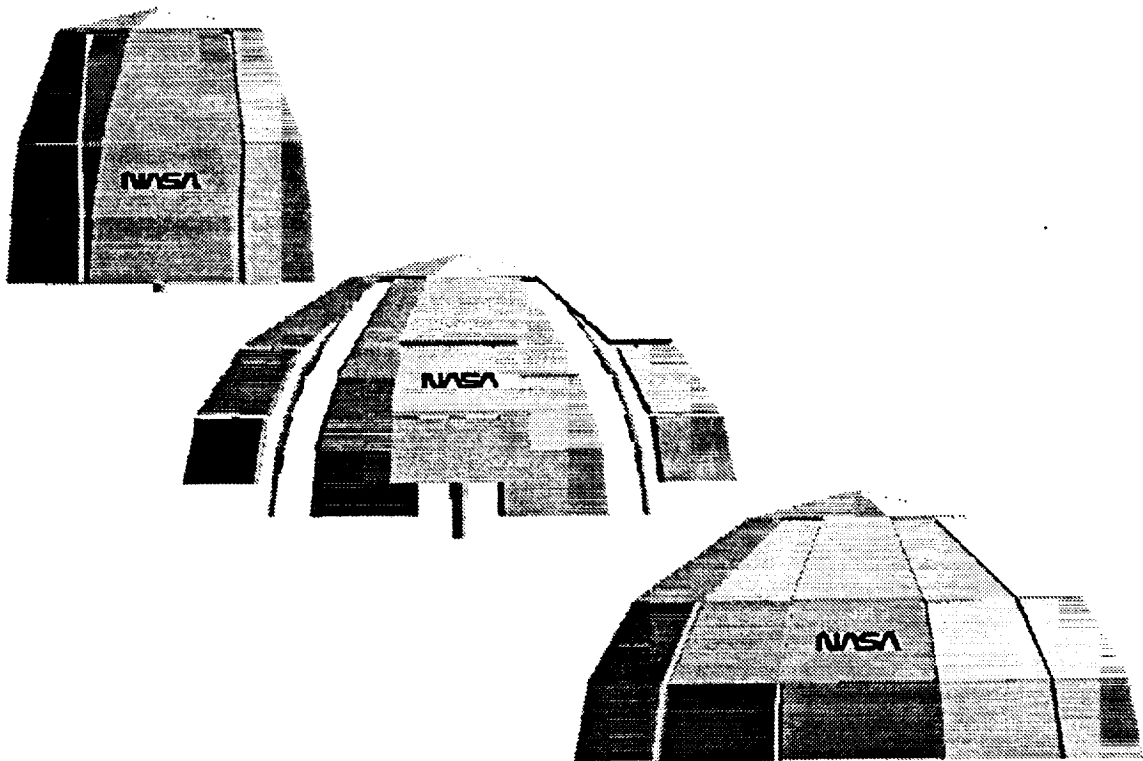

Figure 3-5. Deployable Domed Habitat

Robotic construction could be aided by the IMV or by an enhanced version of the FTS (see later section). Figure 3-6 shows two approaches for a dome 26 meters in diameter and 13 meters high. Both were designed to withstand internal air pressure of 10 psi and an external shielding thickness of 1 ft. Inside, overlapping membranes or an inflatable bladder is used to seal the joints. Analysis indicates that curved honeycomb panels should be used instead of flat panels.

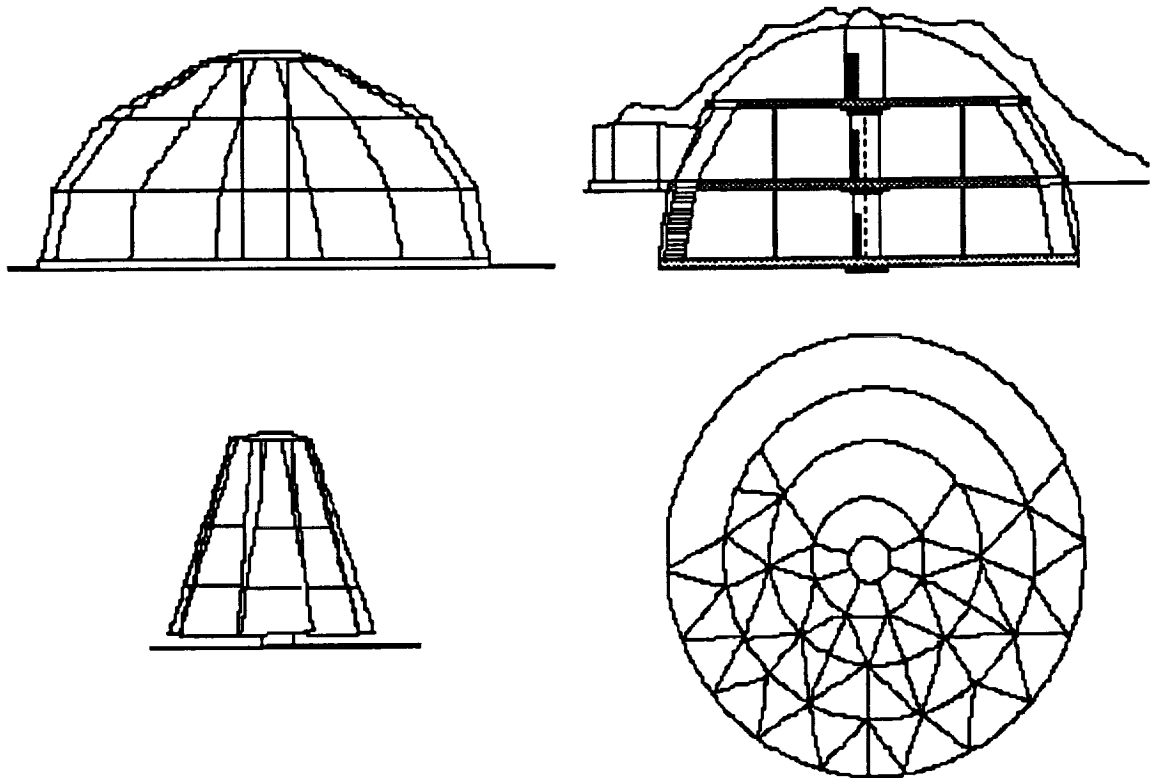

Figure 3-6. Design of Domed Habitat

NASA Goddard/Fairchild's design for an FTS constructed Martian habitat uses multiple pressurized smaller modules instead of a single pressurized module. For more details, see the NASA Goddard/Fairchild report.

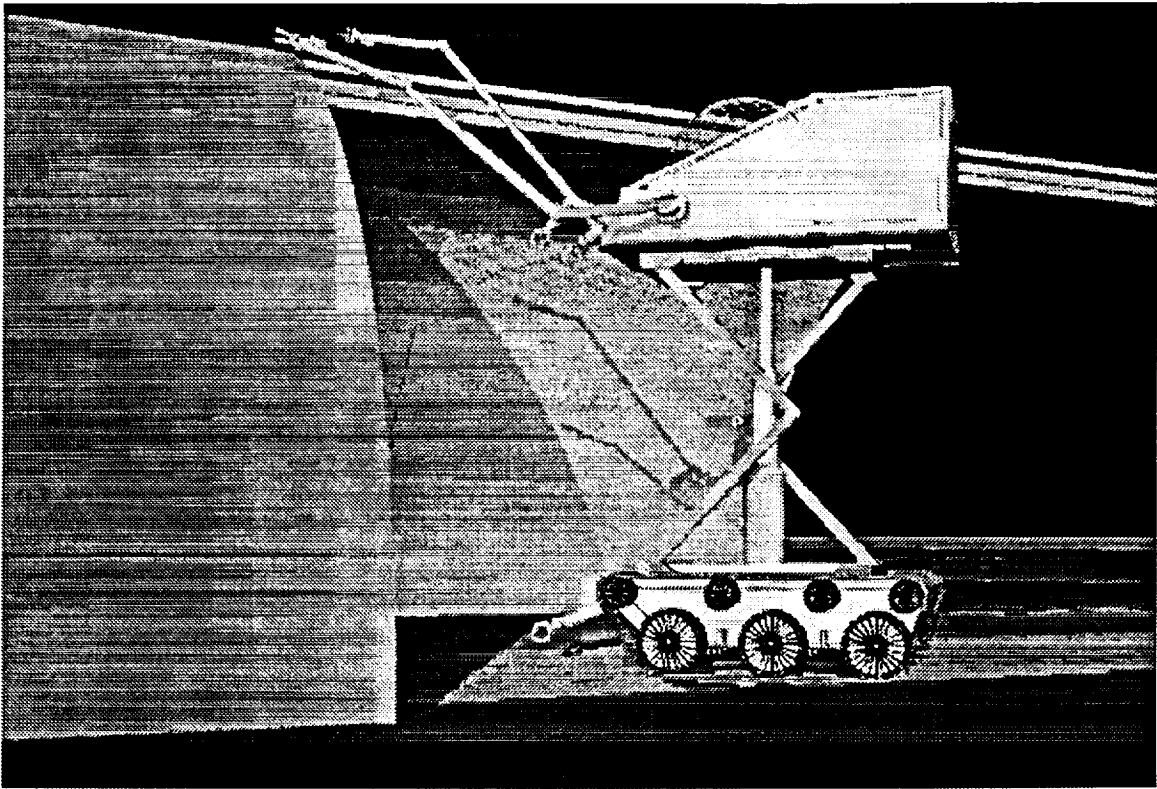

Figure 3-7. IMV Constructing Module Habitat

3.4.2 Modules

Another concept uses space station modules. These modules are covered by regolith to provide radiation shielding. These modules can be placed in tunnels dug out by the robotic front borer described above to provide radiation shielding.

Figure 3-7 shows the IMV assembling the framework for a large cylindrical modular habitat. The panels are curved honeycomb structures. The IMV is shown using its high reach capabilities and a welding end effector.

3.4.3 Shielding

Both lunar and Mars habitats need to be shielded against radiation. Several methods were developed. One method is to construct the habitats on the surface and to place shielding around them and on top of them. The IMV can be employed for collection and installing the regolith on the habitat (see Figure 3-8).

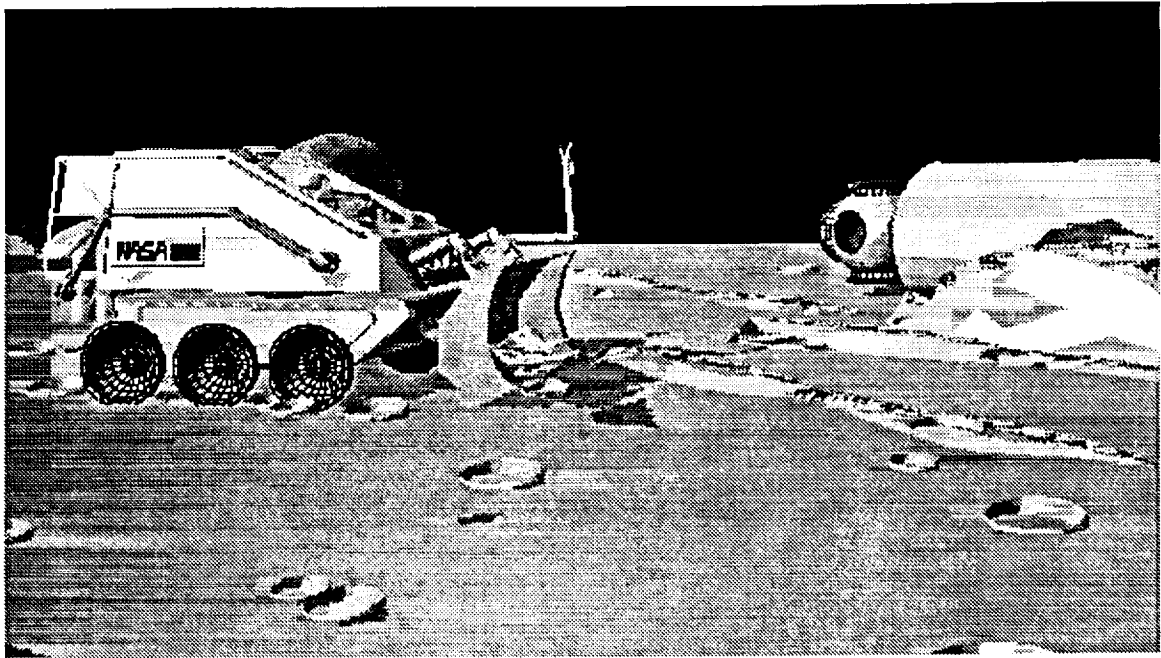

Figure 3-8. Radiation Shield for Habitat

3.5 RELIABILITY

A failure rate analysis study was performed on a lunar base concept that was developed by Boeing as part of this special assessment. The study results serve as a basis for determining spares allocations, maintenance activities, and other logistic requirements.

The mean time between failure (MTBF) for the major systems were derived. Overall it was found that one failure in 58 hours can be expected.

The failure rate data was derived from published aircraft/spacecraft data spanning 1960 to 1985. These results clearly show that appropriate levels of Automation & Robotics need to be provided to maintain the surface systems in proper operating conditions. Some assumptions used in this analysis are:

- Random failure characteristics for both mechanical and electrical equipment are the same.
- Lunar operations occur during lunar day.

The methodology used to establish equipment failure rates is as follows. First a list of the major end items in the lunar base configuration was made and the component parts of the end items were identified. Generic failure rate data was then collected and the failure rate data normalized to the lunar environment.

In general, the generic failure rate data was first normalized to the environment of an airborne, uninhabited fighter. Then the data was further normalized to the lunar environment. The mean time between failures is then found by taking the reciprocal of the failure rate data.

The analysis revealed is that the rover wheels are the most critical items, and that a spares provision of 15% is considered adequate.

For more details, see the Boeing report , *Engineering Analysis for the Design, Emplacement, Checkout and Performance of Robotic Lunar Surface Systems*.

3.6 ENHANCED FTS, MINING/CONSTRUCTION

An enhanced FTS could be used to aid in the construction of habitats in mining operations. An all-terrain vehicle is needed to provide the FTS with mobility to perform the tasks. Fairchild developed two concepts, one with tracks, the other with wheels. The track system is preferred over the wheel system because of stability and traction. Reliability in a track system, however is a problem.

In the analysis the FTS is not used to perform the mining tasks but is used for maintaining the mining equipment.

The FTS would be used to perform the following representative tasks:

1. Vehicle servicing:
 - module exchange
 - cleaning
 - simple repair
2. Process plant servicing.
3. Habitat construction.

The tasks identified place requirements on the FTS and the equipment to be serviced:

1. The arms and joints of the FTS need to be strengthened in order to be used for these operations.
2. The FTS needs to be capable of self-servicing.
3. Mining equipment subsystems need to be modular and designed to be accessible to the FTS.

3.7 ADVANCED ENGINEERING SOFTWARE

Advanced engineering software is required to provide semi-autonomous control of surface base systems. Semi-autonomous control of operations such as mining, LOX production, propellant handling, and routine maintenance is required.

Figure 3-9 shows a matrix of tasks to be performed by robotics and the functions necessary for a planetary base. Figure 3-10 shows a software architecture approach for the planetary base.

For semi-autonomous operation an important and necessary element is a fault detection, isolation and recovery (or reconfiguration) (FDIR). Figure 3-11 shows a high level view of one architectural approach.

A concept for an intelligent maintenance robot was developed to alleviate crew time requirements. The control architecture for the robot has the following:

1. Intelligent control
2. Distributed problem solving
3. Integrated control strategies
4. System-wide communications

Functions	Tasks																	
	Regolith Shield Wall Setup	TCS Reactor/Sunshade Emplacement	Comm. Antenna Installation	Energy Storage Pallet Emplacement	Imenite Reactor Emplacement	Transfer Line Installation	Imenite Ore Mining	Imenite Transport to Reactors	Gangue Disposal	Imenite Reactor Loading	Imenite Reactor Dump	Imenite Reactor Cleaning & Servicing	Move Disabled Lander	Service Lander	Service Solar Array	Service Energy Storage Pallet	Service TCS Equipment	Service Robotics Equipment
Self-Unload	●	●																
Light Mobility, Materials & Equipment Transport		●								●	●							●
Heavy Mobility, Materials & Equipment Transport		●	●	●	●							●	●					●
Light Low Lift/Positioning																		●
Light High Lift/Positioning																		●
Heavy Low Lift/Positioning																		●
Heavy High Lift/Positioning		●	●	●								●						●
Light Excavation/Grading		●	●	●														●
Light Materials Placement		●	●	●														●
Manipulation, Tools Use		●	●	●														●

Figure 3-9. Surface Tasks

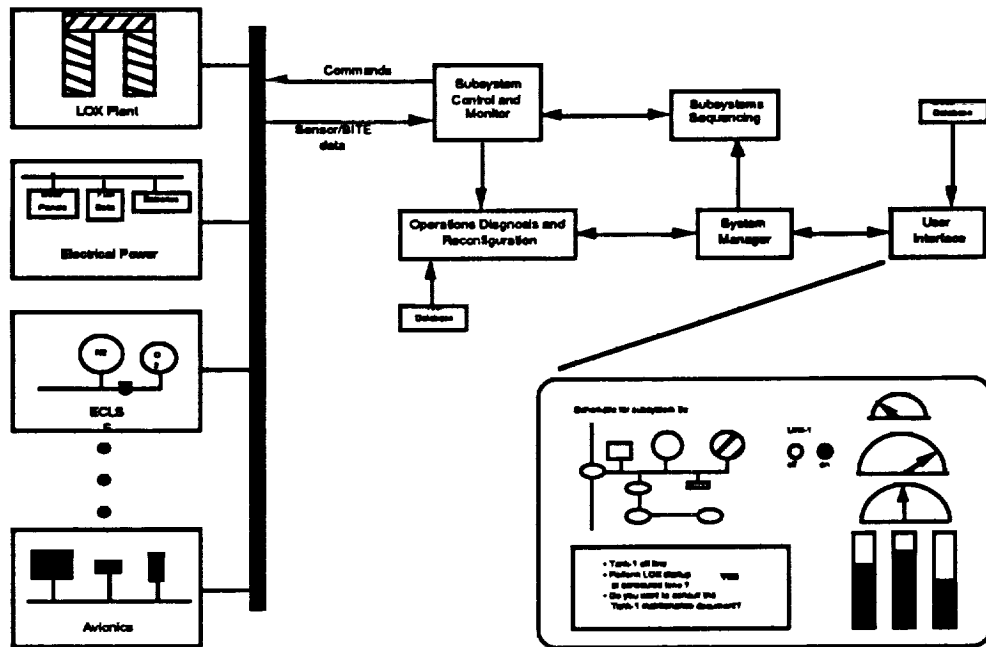

Figure 3-10. Planetary Surface Operations Software

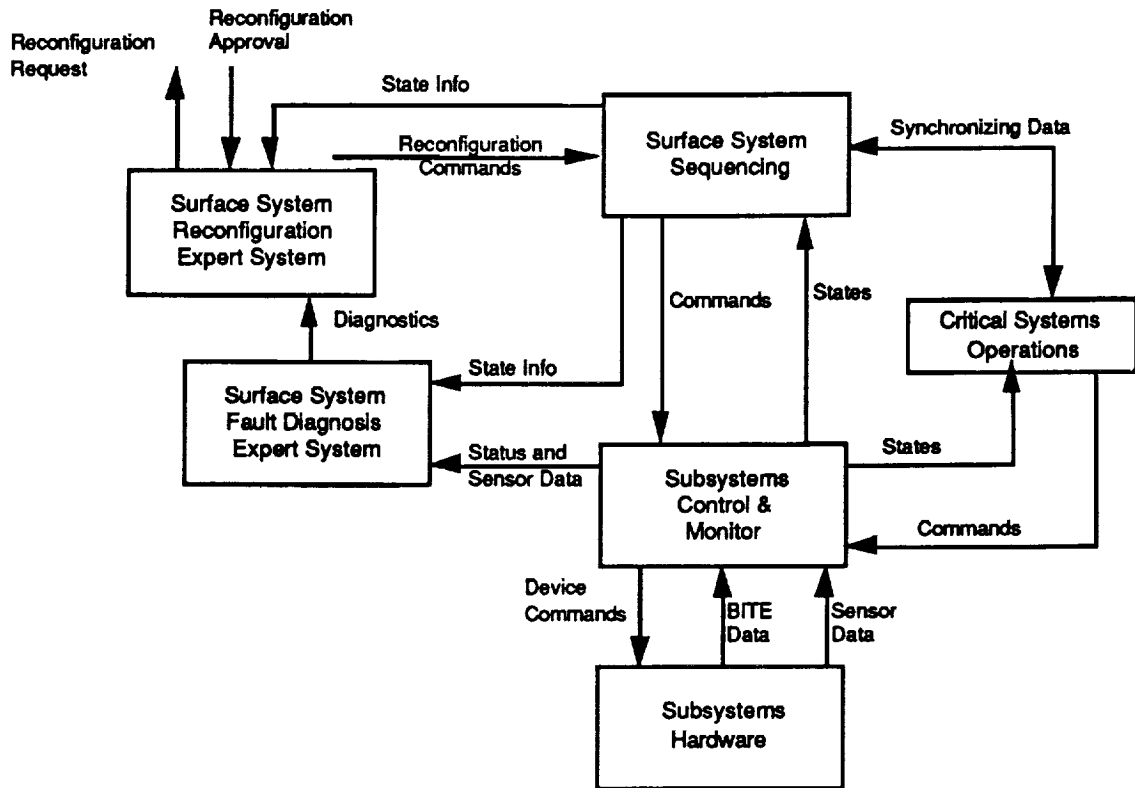

Figure 3-11. High Level View of Surface System FDIR Expert System

5.0 SIMULATIONS & VALIDATIONS

5.1 TRADEOFF METHODOLOGIES

5.1.1 THURIS Program

The THURIS program is an A&R/Human Performance tradeoff analysis tool that was developed at Marshall Space Flight Center by Steve Hall. It can be used to determine the best design option among the following operating modes:

1. manual
2. supported
3. augmented
4. teleoperated
5. ground supervised
6. on-orbit supervised
7. independent.

In this year's effort, the THURIS program was computerized for use on a Macintosh computer system. This allows the A&R/Human Performance crew size studies to be performed in a systematic fashion.

There are three primary inputs for THURIS. The first is a selection from among 37 generic representative activities. The second input is the time required for that activity. The third input is the number of repetitions for that activity.

It was found that THURIS tends to push results toward a man intensive mode. This is due to the high software cost assumptions.

5.1.2 Econ ADSS

A feasibility study was performed for an Advanced Decision Support System (ADSS). The ADSS would be useful for determining a cost effective mix of man/robotic activities for OEXP missions at a level higher than that provided by THURIS. The mission assessments would be performed using a model that has an interrelated set of input/output activities. The model consists of the following nodes:

1. Earth surface.
2. LEO (eg. Space Station).
3. Target planet orbit.
4. Target planet surface.

Each node is modeled as inputs, processes and outputs under the control of a "chief of operations". Each chief is responsible for specifying the nature and timing of resources required, with the option to process supplies together with any local resources to provide the finished products. These finished products include such items as:

1. Vehicles launched.
2. Crew supported.
3. Experiments conducted.
4. Infrastructure deployed/operated.

The model enables cost tradeoffs to be performed. The cost estimates will be a function of the design approach and environmental factors.

5.2 GRAPHICS/VIDEO DEMONSTRATION

Full color, three dimensional graphics of selected A&R/Human Performance concepts were created using the Macintosh II computer. A series of these graphic images of the Intelligent Maneuvering Vehicle (IMV) was created to generate a video presentation of the concept. The purpose of the video is to show the versatility of such a vehicle for construction, serving, repair and rescue operations. Examples of these graphic images are shown throughout the report and in the following figures.

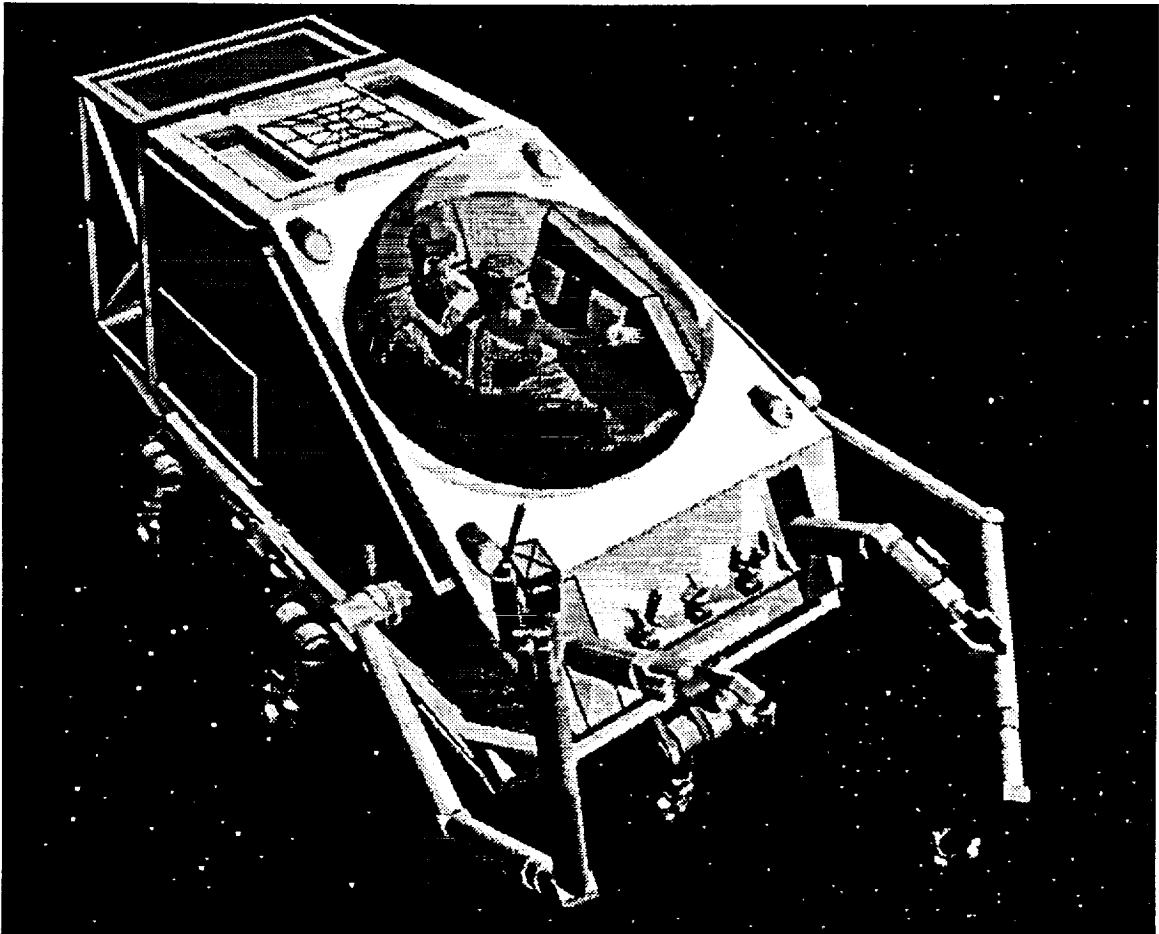

Figure 5-1. IMV In Orbit

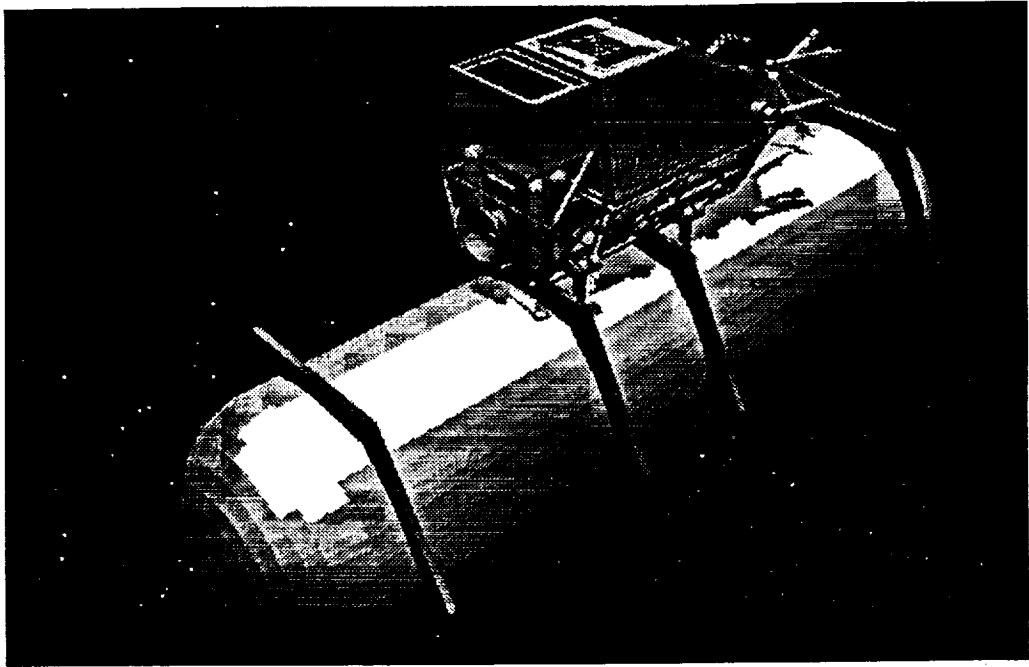

Figure 5-2. IMV Transporting Fuel Tank

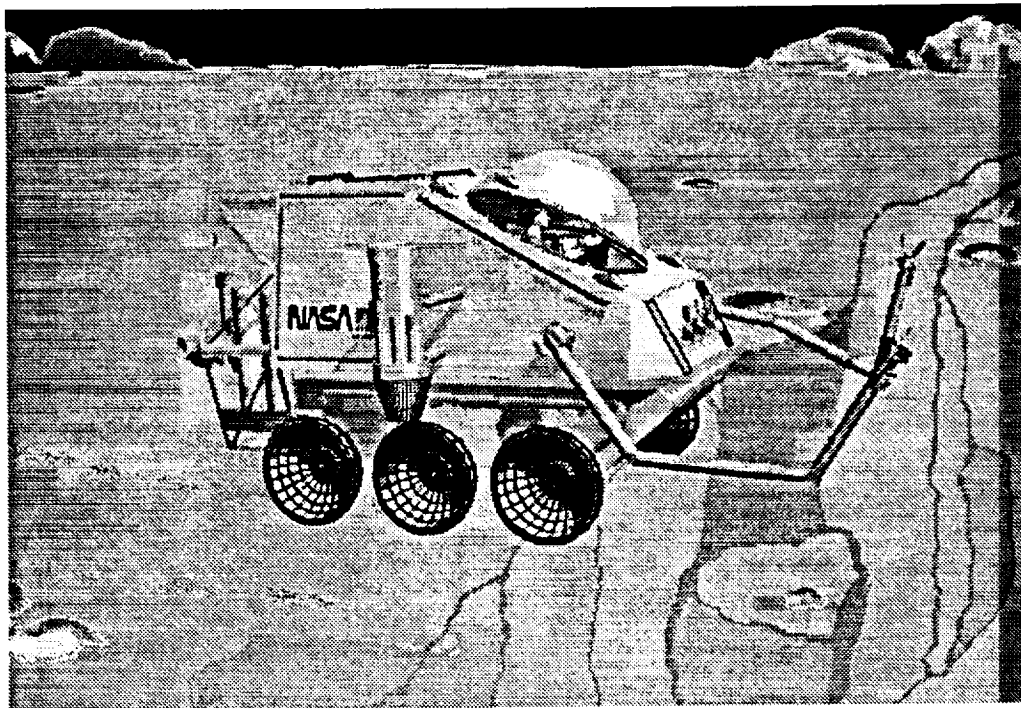

Figure 5-3. IMV Using Thrusters to Traverse Ravine

5.3 FTS METRIC TOOL

The assembly of the aerobrake was used as a reference task to evaluate a metric tool based on the FTS experience. A sample question was, should the aerobrake be assembled by EVA crew using fasteners or by a specialized welding robot?

5.3.1 Metric Development

A metric is a "yardstick" allowing comparison of alternatives against a scale via some scoring method. The objective here was to define a methodology by which advanced mission activities, and in particular in-space assembly approaches, may be compared. The in-space assembly tasks considered include:

1. Aerobrake assembly and inspection.
2. Propulsion systems assembly and servicing.
3. Energy systems assembly and servicing.

Ideally the metric tool would enable the user to address the following question: Given two unique system assembly concepts, which is preferred? For instance, should the aerobrake be assembled by EVA astronauts making bolted connections or by a specialized robot performing welding operations?

There are several approaches to addressing this question:

1. First design the assembly item and select an assembly technique. Then determine which assembler (EVA or robot) is best suited for the task.
2. Select an assembler. Then, trade off various assembly item design and assembly techniques in order to determine which combination optimizes the capabilities of the given assembler.
3. Trade off system assembly concepts based solely upon given design requirements. In other words, trade off specific assembly item design which are optimized for particular assemblers and assembly techniques.

In the Space Station studies, the availability of FTS has driven the tasks to be evaluated by the second method described above. However, the availability of FTS does not drive system assembly concepts for the interplanetary missions to the same degree.

To avoid biasing the results, the third method should be used. The selection of the assembler, the assembly technique and the design of the assembly should ideally be a parallel process.

5.3.2 Metric Formulation

The scoring method chosen (or the figure of merit) is in units equivalent tons to orbit which is a function of weight, dollars and time.

Parameters that need to be considered in the trade-offs include:

1. Costs associated with the assembly item:

- a. Design and development
- b. Fabrication
- c. Integration and test
- d. Launch mass
- e. Ground support equipment
- f. Maintenance

2. Costs associated with assembly technique:

- a. Process design and development
- b. Process expendables
- c. Launch mass of special tools and expendables

3. Costs associated with the assembler:

- a. Design and development cost associated with:
 - i. EVA suit and equipment modification
 - ii. IVA equipment modifications
 - iii. FTS modifications
 - iv. Dedicated robot
- b. Fabrication costs associated with the above (i-iv)
- c. Integration and test costs
- d. Launch mass
- e. Ground support equipment
- f. Maintenance
- g. Training
- h. Cost of EVA time dedicated to task
- i. Cost of IVA time dedicated to task

4. Costs associated with the system assembly concept in its entirety:

- a. Safety risk
- b. Personnel risk
- c. Schedule risk
- d. Cost risk
- e. Quality of performance risk.

All costs were converted to a common cost unit (equivalent tons to orbit). The conversion from dollars is \$4M is equivalent to 1 ton to orbit. There were two conversion factors for hours, one for EVA hours and one for IVA hours. The conversion is 40 IVA man-hours or 20 EVA man-hours is equivalent to one ton to orbit.

5.3.3 General Findings

General findings from this study portion are the following:

1. Costs and risks cannot be established independent of design concept detail.
2. Detailed design concepts cannot be established without presuming that a particular assembly technique is to be used (welding, riveting, bolting etc.).

3. Some assembly techniques are inherently biased toward robotic operation whereas others are biased toward EVA.
4. In order to perform a fair comparison between alternative system assembly concepts, the assembly item and assembly technique must be tailored to each assembler prior to performing the trade-offs.
5. Trade-offs between competing assembly approaches must be performed.

5.3.4 Specific Findings

Specific findings include the following:

1. Typically, task evaluations performed in Space Station studies apply the ground rule that all tasks and hardware must be EVA compatible.
2. Assembly items are therefore predefined by EVA constraints. FTS is being designed to deal with these constraints which are not necessarily optimum from its point of view.
3. Task timelines and activity flows which have been developed reflect these constraints.

5.3.5 The Applicability of FTS to Advanced Mission Activities

The feasibility of using the flight telerobotic servicer (FTS), with and without modifications, to perform OEXP mission tasks was evaluated. The mission tasks include:

1. In-space assembly:
 - a. Construction of the vehicle assembly hangar on the Space Station
 - b. Assembly and servicing of the Mars vehicle at Space Station
 - c. Rendezvous, docking and fluid transfer operations involving Mars vehicle fuel tanks

2. Lunar/Martian ground operations:

- a. Mining on the Lunar/Martian surface**
- b. Construction of a Mars habitat.**

5.3.6 Assembly of Vehicle Hangar

The assumptions for the assembly hangar are the following:

- 1. Two hangars are to be built, one at a time.**
- 2. The configuration is a cube with 20 m on a side.**
- 3. The construction technique is wall panel construction using rigid face sheets over a dense foam core.**
- 4. A powered door is located at one end.**
- 5. Utility ports are required on the inside surface on all the fixed walls.**
- 6. Distributed lighting is required on all the walls.**
- 7. The hangar is not pressurized.**

Additionally, there are hard points on one wall for vehicle attachment. A "footing" for the FTS and astronauts is also required. The five meter truss components should be used to the greatest extent possible. Penetrations through the walls for fittings should be minimized. The door may not be needed if the hangar is pointed at the Earth. Reflected light from the Earth may also provide adequate lighting during portions of the orbit.

A stacked sequential assembly approach minimizes the mobility required of the robot. In the initial assembly step, all equipment and parts are brought to the nadir keel of the Space Station. The equipment includes the FTS, the mobile servicing center (MSC), a mobile transporter (MT) and a remote manipulator system (RMS).

The role of the MSC/RMS is to deliver parts and to move the FTS. The FTS performs operations including placement of assembly jigs and corner guide posts, panel placement and fitting of utilities and lighting. The FTS is also used for inspection and repair of the hangar. In an emergency, the FTS would be required to handle operation of the hangar door.

In the assembly scenerio, the FTS is used to add extensions to the Space Station trusses. Panel feed guides are installed along two vertical trusses. The panels are fed from one end by the FTS and then slid to the bottom. The panels are 2.5 x 20 m in length.

Corner posts are then installed and the first wall assembled is pushed to the rear. The panels for three of the perpendicular walls are located using the corner post guides. The fourth perpendicular wall is left open. The wall assembly is continually pushed rearward to allow installation of the next set of panels.

The final wall is installed in a manner similar to the first one. The FTS then performs inspection of the entire assembly.

This assembly sequence has not been optimized. Details regarding panel to panel connection need further study. Installation of utility trays, lighting fixtures and other parts were not studied. Alternative methods of extending FTS's reach to perform the assembly tasks should be investigated.

Some of the assembly issues that arise include:

1. Passing fittings through panels.
2. Strength and toughness of panels with respect to robot handling.
3. Problems associated with repair/replacement of panels.

The current scenario uses captured panels which cannot be removed without disassembly of a portion of the hangar. This was done to minimize the need for robot mobility. Therefore, repair patches would be required for this scenario.

Three preliminary conclusions can be made regarding the assembly of the hangar by the FTS:

1. The FTS can carry out the assembly of a vehicle hangar without modification.
2. The MSC/RMS is needed to provide mobility and reach.
3. Assembly by EVA may be easier in that attach points and utilities are far less of an issue. However, other concerns arise such as safety.

5.4 INTELLIGENT COMMUNICATING SYSTEMS

The Trans-Earth injection system and Trans-Mars injection system have the least advanced engineering software (AES) requirements. This is due to the maturity of expendable propulsion technology. The Mars lander module and Mars ascent vehicle have only minor AES requirements due to the short duration autonomous nature of their functional usage. The Mars orbit vehicle (MOV) has the highest requirements for AES since it is the focal point for mission control during Mars transit and orbit.

5.4.1 Advanced Engineering Software

The purpose here was to identify potential advanced engineering software (AES) applications for future NASA space missions. The focus was on those AES applications relevant to the mission areas of in-space assembly and manned Mars spacecraft. The identification of applications for AES is based on the ability of AES to provide cost effective or improved mission-success solutions to expected barriers. Intelligent communicating agents (ICAs) is one kind of AES technique that is investigated in detail.

Practical applications of ICA technology related to NASA's mission objectives are investigated. Recommendations of ICA utilization are limited to those areas where ICAs are deemed necessary to meet a mission objective or to overcome a barrier to mission success. An alternative AES architecture is presented if ICA technology does not meet either criteria.

The architecture for software implementation of ICA's is currently being investigated by several institutions. Defining methods for cooperative problem solving is the general theme of the research. Cooperative problem solving is a high level interaction among software agents. This is necessary because ICAs will need to pool their knowledge and capabilities.

5.4.1.1. Background

AES results from the integration of:

1. Artificial intelligence (AI) problem solving techniques, (includes expert systems)
2. Language understanding/speech recognition,
3. Robotics/Image understanding,
4. Learning,
5. Neural nets.

An intelligent agent is an AI system that exhibits semi-autonomous real-time behavior in complex environments. This requires perception of environmental signals and/or data, goal-directed reasoning to compute and execute actions in real-time. It also must have the ability to react and plan around unpredictable events. Figure 5-4 illustrates an agent's cognitive structure.

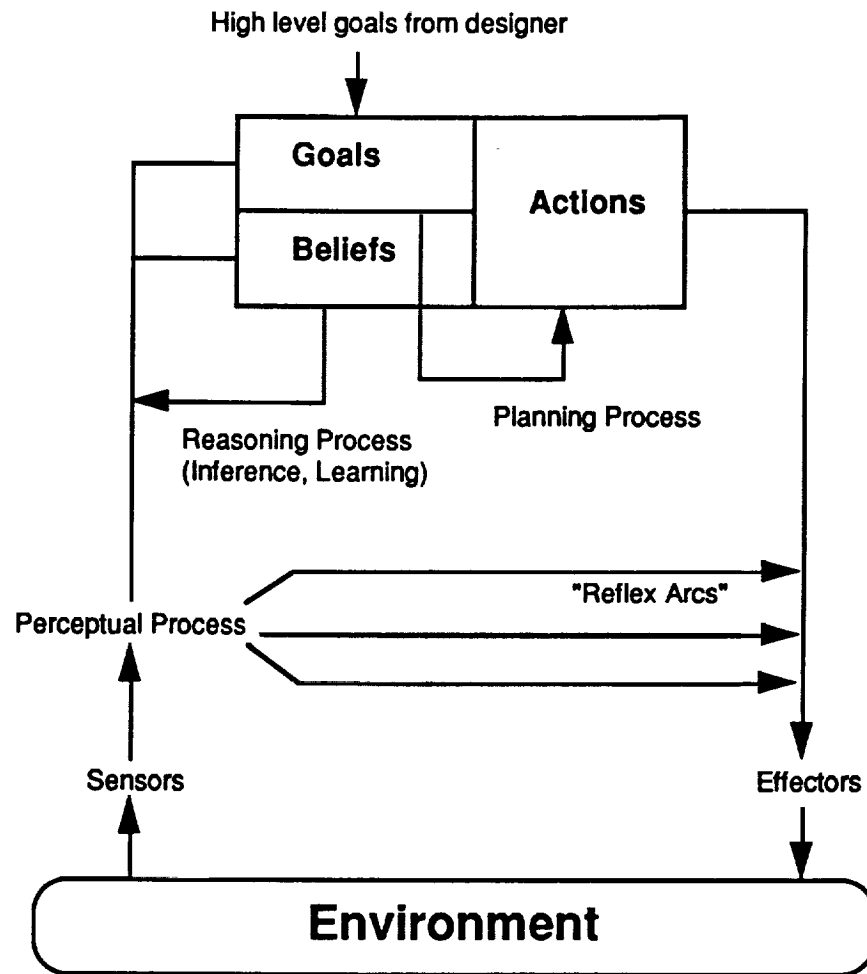

Figure 5-4. Cognitive Structure of an Intelligent Agent

An ICA is an intelligent agent that is an element of a set of distributed agents which communicate with each other to collaborate in performing a task. For an ICA to cooperate effectively with other agents, each must have certain abilities:

1. Reasoning about the environment including the beliefs, desires and intentions of the other ICAs.
2. Communicating to exchange information about the environment and intentions to act.

3. Reasoning about actions and events, including reasoning about the effects of actions.
4. Forming and executing cooperative plans.
5. Monitoring and synchronizing the execution of individual plans.
6. Performing reactive real-time planning of the actions it is capable of executing.

Some advantages of an ICA over an IA are:

1. Fail-soft degradation. Failure of one component will not paralyze the entire system. Degradation will be gradual and not sudden.
2. Upward extensibility. It may be possible to incrementally add elements to the system. The abilities of the systems are increased as new resources become available.
3. Available access of specialized information or equipment. Some elements of the system can run programs or perform tests that other elements are unable to perform.

The major constraint for in-space assembly is the maturity of sensor and effector technology. Efficient processing of various data to support spacecraft subsystem operations is the main constraint for a manned Mars mission. This is more of a software problem than a hardware problem.

5.4.1.2 Barriers to Mission Objectives

Based on the current technology in-space assembly scenario, there are several reasons why it would not be cost effective to automate the process using ICA or other AES technology for in-space assembly:

1. The cost of robotics technology is extremely high.
2. Lack of repetitive operations that require specialized robots.

3. It is more cost effective to utilize the manpower available at the Space Station.
4. A robot with some telepresence hardware is more cost effective than generalized robotics intelligence.

5.4.1.3 Implementation Issues

Effective implementation of ICAs requires advances in several areas. In speech recognition:

1. Voice recognition under varying conditions.
2. Little "training" for system users.
3. Understanding of words or sentences.

In model based reasoning:

1. Determining the cause of a difference between modeled and sensed value of a sensor (maybe the sensor has failed).
2. High-fidelity models that accurately describe complex real-time systems must have efficient methods for updating their internal states in order to maintain rapid changes in the external environment.
3. An increase in model accuracy should not have non-linear or exponential increase in model reasoning time.
4. Isolating causes when there are multiple faults or intermittent faults.

Sensor fusion refers to the process of combining various sensor data streams or their results into an integrated representation. Some advances in data fusion techniques that would facilitate implementing an operation ICA system are:

1. Mature optical and analog neural network sensors for vision.
2. Robust and reliable procedural approaches for sensor fusion and conversion of low-level data into high-level representation.

Reasoning with incomplete knowledge or data is a central problem in AI. Some needed advances are:

1. Improved computational efficiency of intentional approaches. One approach to improvements may be in belief networks.
2. Sound theoretical foundations for extensional approaches.
3. Improved computational efficiency of truth maintenance systems.

Required advances for real-time reactive planning include:

1. Mature parallel software technology for operations such as planning, sensor data assimilation, effector control, etc.
2. Control structures which permit real-time interruption, both scheduled and unexpected, with little impact on current planning and effecting operations.

5.4.1.4 Conclusions

In-space assembly was found to have little need for an ICA software system. This is because of the inherently special purpose nature of operations and heavy dependence on sensor technology which is too immature at this time. The manned Mars mission also does not have a need for ICAs but does have a strong need for AES to support spacecraft autonomy and maintenance.

The reasons for not needing ICAs are two-fold. First, the domains are too specific. An ICA's general purpose reactive behavior is not cost effective or warranted for the specific demands of in-space assembly or the manned Mars mission. The second reason is the software barriers. There are some very fundamental barriers that have to be overcome before even a prototype ICA can be built.

ICA technology would become an important factor as exploration type missions become more advanced and require more autonomy. A need for reactive general problem solving capability will be exhibited. It is important that research begin now. Research should be directed toward several areas:

1. Potential AES architectures for space operations should be defined as scenarios develop.
2. A prototype ICA needs to be developed soon to be tested in a simulated environment.
3. Study software issues associated with AES architecture given above for the manned Mars mission.

Several AES architectures have been recommended. For in-space assembly, EVA's in conjunction with televideo and/or telepresence robotic technology would be sufficient. For manned Mars mission, AES could automate spacecraft operations, perform subsystem health maintenance and fault detection, isolation and reconfiguration. AES could also provide a level of decision support for the crew when communication is lost with mission control. Finally, software support of spacecraft operations is crucial for assisting the crew in daily activities.

5.4.2 Finite-State-Machine Architecture

This is a simple architecture that allows easy implementation of communicating agent techniques. It is best suited for simple, repetitive tasks. The elements of this type of architecture are:

1. Agent – A device operating independently but in cooperation with other agents to perform a task.
2. State – A condition of an agent and its controller corresponding to the agent's immediate task requirements.
3. State transition – Triggered by an event which causes transition to a new state and corresponding sub-task.
4. Message – Sent from one agent to another to effect stimulation and coordination of actions.

A good example of how a very simple ICA system might operate is for a mining operation proposed previously. The operation uses carts and diggers on sets of tracks. Each cart and digger is an agent independent of the others. Each has its own agenda for doing the work and communicates with the others through a simple set of messages. They are programmed to request help from a supervisory control whenever they encounter a situation that they don't understand. The supervisors (most likely human) can exert complete control over the units via a teleoperated control system.

5.4.2.1 States

Each unit encounters a sequence of states during its operation. An example of a branch line cart includes:

1. outbound with regolith
2. transfer regolith at digger
3. inbound with waste
4. transfer at mainline.

A separate controller may be provided for each state. A particular set of tasks and commands corresponds to each state making efficient use of limited computational resources available on the cart. Any other states can be built in such as a "sleep" state and a "junk self" state.

5.4.2.2 Messages

Any device that performs a fairly regular, cyclic set of tasks can be controlled along a similar system. The element of communications is a very important one. A rich enough set of messages needs to be defined plus a robust communication link.

5.5 PATH PLANNING

Path planning plays a critical role in any construction project. Path planning is the process of deciding which pieces go where and when and how they should get there from their original location. The complexity of the problem varies greatly with the number and size of the pieces being assembled. For example, the ability to move outside the work area greatly simplifies the problem. However, this is usually only practical when the pieces are not much larger than the manipulator.

Full three dimensional mobility and a micro-gravity environment make the in-orbit assembly domain spatially less constrained than that of other assembly domains. However, the large size of the structures, the constraints on energy and momentum and the delicacy of the parts all add new complexity to the problem.

5.5.1 Literature Review

There has been little research on path planning strategies for in-orbit assembly. There has been a wealth of work done in the fields of theoretical computer science and robotics. Most of the theoretical work has concentrated on variations of the piano-mover's problem. This is the problem of moving a large irregularly shaped object through a very tightly constrained space. Unfortunately, assumptions are made that make the solutions irrelevant to practical path planning. These assumptions include perfect knowledge of the shape of the object, perfect knowledge of the work space, a completely static environment, infinite maneuverability and the movers take up no room. Therefore, most of the cited work is from the robotics domain with very little from the piano movers problem. A brief description of some techniques follows.

5.5.1.1 Two-Dimensional Environment

Two dimensions are enough to characterize most terrestrial path planning problems. While the use of a two-dimensional techniques is inadequate in the three-dimensional environment of space, this does not preclude the extension of two dimensional planning techniques for operations in three-dimensional spaces.

Grid based

Many of the path planning systems found in the literature use a tessellated model of space to represent information about the environment. A rectilinear grid is the most common tessellation used. Each cell of the grid characterizes some portion of the space being navigated by the robot. A search strategy and a cost metric are used to find the optimum path through the space. Memory requirements are a restriction for planning paths through a large, detailed space.

Some of the problems have been overcome by extending the representation to a grid-based hierarchy. The most common form is a quadtree. A quadtree is a recursive subdivision of space into its four quadrants. This allows the construction of spatial models that characterize different portions of the space at different levels of resolution.

Configuration space

The principle of this approach is to define each object as a vector, referred to as its configuration. The vector contains the pertinent information on the object's position and orientation in space. The way in which the configuration of the object interacts with the configuration of the robot yields the configuration space (Cspace). This reduces the problem of finding a path for a robot with finite size through a set of obstacles to the problem of finding a path for moving a point through the Cspace.

Path planning systems operate by finding paths for a point moving between a start and goal configuration. One of the limitations of the Cspace approach is computing the configuration space for a robot that is non-circular and the orientation of the robot is not fixed. Such problems create surfaces of very complex geometric objects which are hard to characterize in closed form. Most systems assume that there are no geometric constraints on the robot (eg. zero turning radius) but this is simply not true in the real world.

Potential fields

Forces are assigned to attract or repel the robot from features that are in the space. The destination is assigned an attractive force and a repulsive force is assigned to the obstacles. The interaction of the two types of forces creates potential gradients to be navigated by the robot. One problem is the lack of a global view. This can lead the robot to potential minima. A solution is to use a grid based path planner to determine a globally correct path and identify

subgoals along the path. A generalized potential field technique is used to actually navigate the path.

Time varying spaces

This is an added complexity to many of the above methods. The motion of the goal and objects is accounted for. Most of the research has been done for completely predictable environments. Very little has been done on unpredictable domains.

5.5.1.2 Three-Dimensional Environments

The problem becomes very complex when the robot is not considered a point and the objects are allowed six degrees of freedom. Some of the above techniques can translate directly to three dimensions while others do not. Grid based representations and configuration space can translate directly to three dimension.

5.5.1.3 Manipulators: Planning for Robot Arms

Path planning for manipulators is a highly researched topic. Most of the success has relied on the use of configuration space to characterize the acceptable and unacceptable state in which the manipulator may exist. This space is created by associating one dimension with each of the joints on the manipulator. Each point in the space corresponds to a unique joint configuration for the manipulator. Acceptable configurations in the joint space are computed by transforming the obstacle into the joint space.

A restriction is the computational cost of computing the joint space for a manipulator with many degrees of freedom. One solution is to assume that only three of the joints can move at a time. This works well in situations that are not highly constrained. Some situations may require the full ability of the manipulator.

Success has been found in the use of potential field approaches. Good solutions in an uncluttered environment can be found by using artificial potentials. This approach should prove robust if combined with a gross motion planner.

5.5.1.4 Multi-robot Systems

The problem of coordinating multiple robots to perform a given task or set of tasks has not received much attention in the literature. Prioritizing the movement of the objects and allowing only discrete changes in time reduces the complexity.

5.5.1.5 Sensing

One of the key issues in path planning is the acquisition of usable and reliable sensory information both in the creation and verification of the world model. The ability to track a moving object with either passive or active sensing is a requirement of any autonomous or teleoperated system. There are a number of types of sensing. The literature surveyed covers sensing with the robot's external sensory system (camera, lasers, etc.) as opposed to its internal sensor system (joint encoders, etc.).

The idea behind "smart sensing" is the use of strategies to reduce the effective bandwidth of information that is being received by a camera (or other sensor). This results in a vision system that can perform many of the significant functions of the human vision system. The major abilities of this system include: extraction of local characteristics, subsampling and the ability to focus attention. These abilities have been demonstrated using a 256x256 resolution camera at a rate of 30 frames a second. These frame rates are achieved because of about three orders of magnitude in data reduction obtained through the use of "smart sensing" techniques. Foveation (focusing attention) is of particular interest to any system needing to track the motion of an object.

Some systems assume that the environment can be modified to aid in the sensing and tracking of moving objects. A laser scanning system can be used if the objects have photovoltaic diodes attached at critical locations. Real-time tracking for a rigid body translating and rotating in three-space can then be performed.

Some investigators propose a spatial model that encodes limits on the robot's sensing ability directly into the representation. This approach allows a path planner operating on such a spatial model to construct paths that stay within the limits of the robot's sensing abilities. Generic models have been used by some in structured spaces to translate the output of a line finding algorithm into a model of the surrounding environment.

Path planning operating in a partially unknown environment must be capable of planning paths that allow for sensor activity to be combined with the attainment of the desired goal. Verification of path execution involves the scheduling of sensor activity.

5.5.1.6 Uncertainty

There are limitations on the accuracy with which the world can be modeled and/or the robot's ability to execute a given path. One way to address this problem involves adapting the world model to reflect the uncertainty. In a two-dimensional grid model, probabilities are associated with each cell reflecting the chance that the cell is occupied. Some approaches such as potential fields avoid the problem of uncertainty altogether.

5.5.1.7 Reactive

If robots are to effectively operate in the real-world, they cannot rely entirely on planning to generate their actions. A certain amount of their abilities must be generated at a reactive level. The most obvious class of abilities that a robot should have at the reactive level are those that are feedback intensive such as balance. A number of architectures exist which connect sensing and actuation together without the aid of an intermediate planning system. "Subsumption Architecture" has made a significant impact in this area. The approach is to build up layers of primitive behaviors. The higher level behaviors influence the input and output of the lower level behaviors in order to manifest more complex reaction. Other similar work casts the control of a robot into a stimulus-response paradigm. Activity theory is a spatial semantic net used to access a library containing "what to do now information" in order to create a reactive control structure. These systems can respond to unpredicted events but cannot achieve high level planning goals.

Neural networks are beginning to provide some low level reactive abilities that will prove to be useful in a robust robotic system. A neural net has been created that is capable of coordinating the activity between a vision system and manipulator. The system is capable of grasping an arbitrarily located object floating in the robot's visual field. Once the network has learned a sufficiently large set of possible orientations for the object the system can respond to the task in real-time.

5.5.1.8 Semi-reactive

Semi-reactive systems are typified by control structures that have both a planning component and a reactive component. A robot with a certain level of reactive ability allows planning systems to create plans that utilize these abilities without reasoning explicitly about how to manifest such abilities. The general approach is to endow a planning system with a reactive subsystem and to allow the planning system to affect and be affected by the reactive component. Various techniques have been used to resolve the conflicts between planning and action.

Some approach the control of a robot by reasoning explicitly about the time required to plan, and thus can make judgements concerning the benefit expected per unit time for different planning algorithms. This leads to the concept of "anytime algorithm" which is capable of producing plans whose quality is proportional to the time they are given to compute.

Finally, there are approaches where no explicit world model is maintained. Planning becomes a matter of exploiting the physics of the environment being navigated.

5.5.2 Space Construction Problem Classification

This section characterizes more precisely the parameters that can classify a given path planning problem. Once classified, the techniques useful to solving problems in the given domain can be more easily identified. The discussion in this section concentrates on path planning issues for an autonomous system that arise in the low Earth orbit construction domain.

5.5.2.1 Knowledge of the Environment

Characterization of the environmental knowledge available to the system is key to the design of any autonomous system. This is of primary importance when determining what tasks the agent will be capable of and how such tasks are ultimately accomplished. One extreme is if the robot has perfect knowledge about the world and has the capability of precise motion. The other extreme places the robot in an environment without any information about its surroundings or exactly how its actions will effect the environment. In this case the robot must rely on its sensing abilities to acquire information about the environment and correct motion errors. Reality lies between these two extremes.

Ultimately there are three types of uncertainty that must be accounted for in any robot control system:

1. sensory
2. control
3. model.

The factors that influence the level of uncertainty involve the quality of the sensors used to create and maintain the world model and the amount of uncertainty associated with the activities of other agents operating in the space. Systems operating in a space environment must have large safety margins built into them. Space-time models must be used in order to anticipate the result of a planned action. By far the hardest problem in creating a usable space-time model involves the activities of agents not under direct control of the planner (eg. astronauts, teleoperators etc.). One approach uses a table accessed by the current context and a sequence of previously observed states for the agent in question. The limitation of this approach is that it uses no information about the intent of the agent described. Plan recognition is an extremely hard problem but must be solved if autonomous systems are to reason about the activities of other agents.

5.5.2.2 Resources

A robot maneuvering an object using air jets must create plans that consider resource utilization or it may not have enough fuel to slow the object once it reaches its goal location. An astronaut in EVA might also be a resource that the planning system must consider when making plans. Sunlight is a resource used by the vision system for identifying and tracking objects. If the construction moves into the dark in the middle of a critical construction phase disaster may result.

5.5.2.3 Initial and Final Conditions

The problem of determining what the initial and final conditions are for a path planning problem has largely been ignored. All the systems assumed that there were well defined initial and final conditions. However, in many situations the initial conditions are only partially defined and the final conditions may be a function of how the goal is being achieved.

5.5.2.4 Degrees of Freedom

Operations in zero-G three-space result in the need to plan for 12 degrees of freedom for the manipulation of any rigid body. Traditional systems have only concerned themselves with the classic 6 degrees of freedom. This is because all of these systems have operated with objects that are less massive than the system manipulating them. In space construction there are large, massive objects to be manipulated. Therefore, planning in this environment must also consider the six additional degrees of freedom in momentum space. This creates a new complication on the path planning problem by adding a temporal dimension to computations involving even a static environment.

A major implementation concern is that no system can be fully debugged on Earth. Earth-side testing of the assembly process is only an approximation. The most significant differences will be the lack of friction resulting in the need to consider the effects of momentum.

5.5.2.5 Dynamic Environments

There are two types of dynamic environments. In the first, there are other agents with unknown intent operating in an unrestricted fashion in the robot's work space. The other is an environment in which other agents operate only outside of well defined keep-out zones. In the latter situation the only requirement on the robot is to identify when there has been a violation of the zone and to take emergency action. Many representations will allow this type of operation and the hard part is to determine what an appropriate emergency action is. Momentum restricts the speed with which an operation in progress can be halted. In addition, halting may not be the best action to take. Solving this problem leads back to the problem of planning in an unknown dynamic environment.

The problem of planning in an environment where there are other agents operating in the same work space can be broken into two separate problems. One problem is an environment where the agents are communicating their intent to each other. This will allow the robot to map the intended actions into its space-time model and determine if there are any potential conflicts before action is taken. The other problem occurs when the actions of the other agents is unknown. In this situation the robot can only infer what the action of the other agent might be and determine if it will conflict with the current plan.

Operation in dynamic domains also includes the effects of orbital drift due to the interaction between an object and the Earth's gravity. While this effect is minimal when operating in a local environment its effect can cause problems when aligning large parts for assembly.

Planning in dynamic domains requires the ability to provide real-time planning and space-time modeling. Parallel processing is a major candidate for this purpose. Temporal uncertainty also comes into play when dealing with dynamic environments. One agent may report its intended actions but be delayed in its start of plans.

5.5.2.6 Free Flying vs. Mounted

Adding mobility to the sensing and manipulation aspects of a space construction project will allow observation and manipulation to occur in locations where statically located sensors and effectors would be insufficient. However, by introducing a detached mechanism into the planning scenario the normal amounts of spatial uncertainty become magnified. This requires real-time control to keep the robot under safe control.

5.5.3. Classes of Space Problems

There is a wide spectrum with which various path planning problems might be categorized. The main feature is the level of advance knowledge a planning system has about the problem.

Problems may be of a nature that allow the robot's actions to be entirely preplanned. This class is analogous to the automated assembly process used for cars. Problems in this class are partially characterized by the following necessary conditions:

1. The environment is static, the robot controls all moving objects.
2. The star and goal locations of the parts being assembled are known in advance.
3. The sequence of parts assemble is predetermined.
4. Only one part needs to moved at a time.

The robot can assume full knowledge about future states of the world if these conditions are met. The robot can build an accurate model of future states of the world based on the expected results on an action. Any number of steps can be planned in advance of execution. Typically, problems of this class have been handled using a configuration space approach. Boeing's idea regarding the use of the aerobrake as the construction platform contains an assembly problem that meets these conditions so that the entire process can be preplanned.

Problems in which preplanning is useless occur when the time to react to a new situation approaches zero. Systems operating on this class of problems rely on reactive abilities. An example is when a robot accidentally releases a wrench and has to recover it before it gets too far away. Most problems in this class are isolated and robust assembly problems never fall entirely within this class.

Most problems do not meet one or more of the conditions to be a problem that can be preplanned. Yet they require some preplanning in order to perform better than a random walk. In this class, preplanning typically occurs one step at a time. An example is environments where there are other agents operating in the same space. In these situations the robot cannot predict how the environment will appear at all times in the future. Some other agent may be occupying a portion of space considered free when the robot first constructed the plan. This kind of environment can be found in at least two of the scenarios covered by NASA Tech memo 4075. In the Mars human exploration and the manned Lunar observatory scenarios, adding components to the space station is a possibility. These components are for vehicle assembly, propellant transfer and prestaging activities. There is a strong need for automated path planning to minimize the mission impact on the ongoing space station activities.

5.5.4. Suggestions and Implications

Two recurring concerns are minimization of astronaut EVA and the safety of man and machine. These concerns can be addressed by automating many of the processes that would otherwise require human activity. The problem is that current path planning technology is not prepared for implementation in a space construction environment. Two key developments must be made. First, a space-time modeling system capable of providing useful information about activities in this domain must be developed. Second, a path planning system capable of using such a space-time model to assist in automating all or part of the construction processes must be designed.

The space-time model must be a three dimensional representation of the construction environment capable of:

1. Providing useful information about future states of the world.
Generating future states of the world is reduced to a three-dimensional geometric modeling problem for objects being controlled by known processes. GARE (for Telerobot) is the most advanced such system in NASA. The difficulty arises when there are independent agents operating in the space being modeled. The modeling system should take advantage of any intentional and context information it may have about the agents and their surroundings.
2. Providing easy integration of sensor information from multiple sources.
A space-time model is only as accurate as the sensor information it receives. Also, in a space construction environment there are likely to be many sensor sources. Some will be vision and touch but others will be in the form of agents or objects reporting on their current state and/or intentions. The system must be capable of unifying these sensor types in a useful way. Future research is required in this area.
3. Requesting sensor activity in order to maintain the model's integrity.
This implies that the model associates a time dependent reliability factor with each object it has modeled in the space. A model of a static object requires no sensor activity to verify its location but a human controlled object may need constant monitoring. The issue of requesting sensory activity is strongly tied to the need to provide useful information about future states of the world. These sensory activities should be easily generated if the model is reasonably accurate. Scheduling the request is a much more complicated problem. The

state-of-the-art in this area are the sensor scheduling systems being developed for Pathfinder Rover's execution monitoring system and the HST scheduling system.

4. Being reasonably space efficient (on the order of 10-100 megabytes). There is likely to be a practical limit on the amount of computer storage in which the model can be maintained. Therefore, the model must be capable of representing a large work area in an efficient manner. There has been no research on making spatial models memory efficient.
5. Modeling rigid objects with their full 12 degrees of freedom. Geometric modeling of three-dimensional objects in the absence of momentum is a well researched area. The research falls short when the results of object interaction must be reasoned about. This is where the effects of momentum will become critical. This is a high priority item.
6. Real-time computation rates. This is more a restriction on the types of techniques that can be used to implement this list of abilities. One way to achieve this is to use massively parallel computer architectures. Another is to use more computationally efficient algorithms. The problems involved in path planning for space construction are exponential in the worst case. However, if near optimal solutions are satisfactory then performance can be greatly enhanced through the use of heuristics and a variety of search techniques. For the near term, algorithm improvement will be a more profitable path than hardware development because of hardware's long lead time for space qualification.

The biggest problem is that no system has attempted to integrate all of these capabilities into one unified space-time modeling program. Creation of such a model would greatly enhance the safety factor of astronaut and telerobotic activities by providing a mechanism to verify intended activities before actions are executed. This kind of model would be useful independently of any further automation by providing a central location for all agents acting to make requests to reserve space-time pathways.

Path planning must be undertaken to complete the automation process. A path planner should use a space-time model to accomplish objectives. The space-time model must support the modeling needs of the planner. This is highly dependent on the mechanism used by the planner in generating paths.

Path plans for rigid objects with known start and goal locations must be done for the full 12 degrees of freedom. Such a planning system would prove useful for aiding teleoperation or astronaut EVA by providing them with suggested plans for accomplishing a goal. The path-planning capability also enables the automation of manipulating objects with a free-flying robot. This is accomplished by assuming that the robot is connected to the object and planning to move the entire assembly. This level of planning would also allow a free-flying robot to act as a remote sensor for inspection. Issues not adequately addressed in the literature include planning paths for massive objects and planning to include the abilities and uncertainties of the robot and space-time model.

The other path planning issue is planning for a fixed-base manipulator. A free-flying robot may have manipulators that it uses to attach itself to objects requiring manipulation. It would be the responsibility of the manipulator planner to attach the robot to the object. Plans for manipulator control must be generated in real-time. Issues that need to be addressed are planning a grasping motion for moving objects, the effects of momentum on the planning process and planning in the presence of uncertainty.

There are countless problems that occur in designing a general system capable of handling all possible situations. It is recommended that a realistic scenario be created so that path planning issues involved in automating the process can be bounded. A physical testbed would also be advisable in order to more accurately model various type of errors. This will enable a more detailed analysis of the path planning requirements.

5.5.5. Synergy

Space construction is a generalization of space servicing. The planning, reasoning and many other tasks are the same. Current NASA work on space telerobotics, the FTS, issues of servicing the EOS spacecraft and planned conversions of space shuttle external tanks into the Gamma-Ray Telescope all involve issues similar to those discussed above. Surface construction and mobility also require research in these areas.

Further work on path planning for in space construction will eventually require the use of real robots to test algorithms. Experience has shown that simulations do succeed. Only when algorithms are mated to hardware can a program be adequately modified and tested. Fortunately, the telerobotic and EVA retriever testbeds could fulfill most of the needs for the domain if suitable arrangements for their use can be made.

5.6 FEASIBILITY DEMONSTRATIONS

An effort was undertaken to identify concepts that warrant early development of feasibility demonstrations. The following steps were taken:

1. Developed modular concepts for A&R operation in OEXP missions.
2. Characterized modular robotics characteristics (software and hardware modules).
3. Identified key tasks that employ modular robots.
4. Defined projects that demonstrate the leverage obtained from use of modular robots for one or more tasks.
5. Selected the automated aerobrake assembly problem as a case which warrants early development of a feasibility demonstration. Designed a prototype using current technology to demonstrate feasibility.

Other items which warrant development of feasibility demonstrations include:

- 1. automated mining operations**
- 2. automated in-site resource processing**
- 3. automated surface assembly of complex structures**
- 4. automated surface maintenance and repair of machinery**
- 5. automated propellant transfer**
- 6. automated maintenance and repair.**

Within each of the items above, there should be a study focused on man-machine interface issues, especially for process definition and execution language requirements. A key task would be to identify operations which could employ modular robots.

In the feasibility demonstration assessment phase, the prototype performance will be determined. Criteria for measuring performance would be developed and various scenarios will be tested against the prototype. From these feasibility demonstrations, suggestions for modifications to improve space performance will be proposed.

REFERENCES

FY 89 Automation and Robotics/Human Performance Study Reports

- *Engineering Analysis for Assembly and Checkout of Space Transportation Vehicles in Orbit*, Boeing, 1989.
- *Engineering Analysis for the Design, Emplacement, Checkout and Performance of Robotic Lunar Surface Systems*, Boeing, 1989.
- *Reliability Evaluation of A Robotically Constructed Lunar Base*, NASA-Ames Research Center/Boeing, 1989.
- *FTS Capabilities Assessment for On-Orbit Operations and Planetary Surface Operations*, NASA-Goddard/Fairchild, 1989.
- *Advanced Engineering Software for In-Space Assembly and the Manned Mars Spacecraft*, Rockwell, 1989.
- *Human Performance Crew Size Study*, NASA-Ames Research Center, 1989.
- *Computerized Automation and Robotics/Human Performance Tradeoff Tool (THURIS)*, NASA-Ames Research Center, 1989.
- *Automation and Robotics/Human Performance Special Assessment Report*, Working Group Week II, St. Louis, February 1989.
- *Automation and Robotics/Human Performance Special Assessment Report*, Working Group Week III, Orlando, April 1989.
- *Automation and Robotics/Human Performance Special Assessment Report*, Working Group Week IV, St. Louis, June 1989.
- *Automation and Robotics/Human Performance Special Assessment Report*, Planetary Surface Systems, Johnson Space Center, November 1989.

- *Structured Integrity/Smart Sensor Assessment Study*, Jet Propulsion Laboratory, 1989.
- *Automation and Robotics/Human Performance Design Guidelines and Rules*, E. Heer, 1989.
- *Definition of Automation and Robotics/Human Performance Related Terms and Concepts*, E. Heer, 1989.
- *Intelligent Communicating Lunar Mining System*, S. Alexander, MIT, 1989.
- *Path Planning Requirements for On Orbit Assembly of the Manned Mars Sprint Mission Vehicles*, Jet Propulsion Laboratory, 1989.
- *Manned/Unmanned Multi-arm Robotic Vehicle – Construction, Maintenance, Repair, and Rescue (On-Orbit and Planetary Surface Operations)*, Video Script, NASA-Ames Research Center, 1989.