

N 93-26694  
920-37

158367

P-9

**Development of a Material  
Processing Plant for Lunar Soil**

**Ulix Goettsch and Karl Ousterhout**

**Department of Aerospace and Mechanical Engineering  
The University of Arizona**

**Abstract**

Currently there is considerable interest in developing in-situ materials processing plants for both the Moon and Mars. Two of the most important aspects of developing such a materials processing plant is the overall system design and the integration of the different technologies into a reliable, lightweight, and cost-effective unit. This paper develops the concept of an autonomous materials processing plant that is capable of producing useful substances from lunar regolith.

In order for such a materials processing plant to be considered as a viable option, it must be totally self-contained, able to operate autonomously, cost effective, light weight, and fault tolerant. In order to assess the impact of different technologies on the overall systems design and integration, a one-half scale model has been constructed that is capable of scooping up (or digging) lunar soil, transferring the soil to a solar furnace, heating the soil in the furnace to liberate the gasses, and transferring the spent soil to a "tile" processing center. All aspects of the control system are handled by a 386 class PC via D/A, A/D, and DSP (Digital Signal Processor) control cards.



## I. Introduction

The Artemis program, initiated by NASA, is geared toward the development of a Common Lunar Lander (CLL) that will serve as a platform for a wide variety of robotic exploration missions to the lunar surface. The CLL is envisioned as a small lander which is capable of being launched from an existing launch vehicle and that will carry an autonomous payload for performing a variety of experiments. Currently, planned payloads include in situ materials utilization (ISMU) experiments and astronomical observatories. NASA is conducting work in two separate but interrelated areas: the development of the Artemis Lander and the Artemis Lander's payloads. This paper discusses preliminary research underway at The University of Arizona's Space Engineering Research Center to design and build a one-half scale autonomous oxygen production facility for inclusion in the Artemis program.

## II. Mission and Task Requirements

The mission requirements for the autonomous oxygen production facility are straight forward: the plant must be capable of autonomous oxygen production for a period of 35 to 365 days, the payload may have a maximum mass of 65 Kg (143 lbf), the payload must fit within the envelope illustrated in *Figure 1*, and the payload must operate from a platform as illustrated in *Figure 2*.

Additionally, the four main tasks for the autonomous oxygen production facility can be decomposed as shown below in Table 1:

- 
- 1) Soil sample acquisition:
    - Move primary arm and gather soil.
    - Sift soil to remove large Impurities.
    - Transfer sifted soil to crucibles.
    - Transfer crucible from rack to reactor with secondary arm.
  - 2) Reactor operation:
    - Mix solid carbon powder with soil.
    - Insert crucible at the focal point.
    - Control heating temperature.
    - Measure and identify gasses.
    - Remove residue and reprocess to make tiles.
  - 3) Data Management
    - Obtain measurements and store data.
  - 4) Telemetry
    - Adjust antenna and either transmit to Earth or receive data from Earth.

*Table 1. Mission requirements for the autonomous oxygen production facility.*

---

The autonomous oxygen production facility combines two related experiments into one payload. The first experiment, lunar oxygen production, will serve to demonstrate the feasibility of using solar energy to reduce lunar soil and release the oxygen which is bound within the ilmenite (chemically known as iron titanate,  $\text{FeTiO}_3$ ). The second experiment, lunar brick production, will demonstrate the feasibility of making "lunar bricks" from the previously processed lunar soil. At the completion of the "lunar brick" production process, the lunar soil will be in a hardened brick-like form suitable for building lunar structures.

### III. Payload Design, Layout, and Operation

In order for the autonomous oxygen production facility to fit the mission requirements, the current design allows for the four main components - the primary mirror, the secondary mirror, the primary arm, and the secondary arm - to be stowed in the configuration shown in *Figure 3* for space flight.

Once the CLL has landed on the Moon, the primary mirror, the secondary mirror, and the primary arm will deploy and operate as illustrated in *Figures 4 and 5*. The individual components of the autonomous oxygen production facility are illustrated in *Figure 6*.

The turntable and pallet contain the mounting interface to the lander itself. The turntable is the foundation upon which all of the other components of the payload (except the pallet) are mounted. Additionally, the turntable allows for 360 degree rotation of the payload for soil collection, solar tracking, and telemetry. The pallet, which is fixed to the lander and does not rotate with the turntable, is used for storage of the crucibles which will be filled with collected soil for processing. It accommodates both small crucibles (10 g capacity) for oxygen production and large crucibles (50 g capacity) for glass production.

The primary arm is used to collect soil and deposit it into a sieve mechanism which returns large soil particles (rocks) to the lunar surface and fills the crucibles with the fine soil. The arm is a four degree-of-freedom (waist, shoulder, elbow, and wrist) robot with a scoop for soil collection. Besides the waist joint (the turntable), all of the motors are contained in a drive assembly located at the shoulder joint. Torque is transmitted through gear/chain and pulley/cable combinations and position feedback is obtained through the use of optical encoders located at each of the joints. Since the payload must be autonomous, the arm is instrumented with strain gauges to provide force feedback along three orthogonal axis. This will inform the controller in the event that the arm contacts immovable obstacles such as large surface or subsurface rocks.

Once the lunar soil is placed in the hopper by the scoop attached to the primary arm, it is then processed through a sieve consisting of a series of screens with decreasing mesh size. Particles that are too large for production purposes are allowed to exit the sifter at each stage where they are allowed to return to the lunar surface. The fine soil that passes through the sieve is collected in a hopper where it can then be poured into a crucible. This last step is accomplished by rotating the turntable until one of the empty crucibles is positioned directly below the spout of the hopper. After one of the crucibles has been loaded with lunar soil, the turntable is rotated to a position where the secondary arm can pick up the crucible and transfer it to the furnace for either oxygen or glass production.

When producing oxygen, the secondary arm positions the crucible under the transparent furnace lens and against a seal which traps the evolved gas. Solar energy collected by the mirrors focuses

on the soil sample and heats it to the proper temperature for oxygen generation. Once the oxygen production process is completed, the secondary arm returns the crucible along with the spent sample to the pallet. When producing lunar bricks, the large crucible is positioned just above the furnace, where the nearly focused beam hits the soil sample. Gases evolving during the melting process are allowed to escape to the lunar atmosphere. Once the soil sample is molten, the secondary arm positions the crucible over one of molds and pours the molten soil into it. Once the glass sample has cooled, the secondary arm moves it to the materials testing unit where it is ejected from the mold and its mechanical properties are determined.

The solar energy needed to process the lunar soil is collected and focused onto the furnace via a primary and secondary mirror system. The two meter diameter parabolic primary mirror is mounted on a cart which rides a circular arc to follow the sun vertically above the horizon and the turntable rotates to follow the sun horizontally across the horizon. The convex secondary mirror is located at the center of the circular arc to maintain a constant focal length. The secondary mirror directs the collected solar energy downward into the furnace, elongating the beam so that the focal point is inside the furnace. A tracking system, consisting of a two by two solar panel array, is used to track the sun throughout the lunar day. All of the power to operate the robotics, analytical equipment, computers, and telemetry is provided by solar panels which deploy from the rear of the primary mirror. This mounting configuration insures that the solar panels are always optimally positioned with respect to the sun. The only time that the solar panels are not tracking the sun is when either the primary arm is collecting soil or the secondary arm is selecting a crucible from the pallet. When these operations are taking place, power is supplied by batteries.

#### IV. Controls and Electronics

As mentioned previously, all aspects of the control system are handled by a 386 class PC via D/A, A/D, and DSP (Digital Signal Processor) control cards. This hierarchical control system allows for the 386 class PC to act in supervisory mode while the individual motions of each of the axis of movement are controlled via the DSP control cards. Thus, the PC is able to process data taken during experiments or run diagnostics while the manufacturing process is underway.

Although the PC is capable of transmitting data to a mother craft or Earth during the lunar day, a rechargeable battery will be included within the system so that data reduction and communications

can be conducted during the lunar night. During the lunar day, the photovoltaic cells mounted to the rear of the primary mirror will recharge the battery. The electrical power requirements and the masses of the individual components are shown below in Table 2.

---

	Power (w)	Mass (kg)		
Communications	10/120	3.5		
Computer	16	4.25		
<b>Sensors/Actuators</b>				
Servo motors (8)	480.0	6.4		
Flow meters (2)	7.5	0.8		
Pressure sensors sensors (2)	0.2	0.1		
Force/torque sensors (2)	*	1.0		
Proximity sensors; strain gauges			*	*
Flow control valves	2.4	1.2		
Thermocouples (2)	*	*		
CCD Camera (1)	3.0	0.2		
Mass Spectrometer (1)	2.0	0.5		
Total	495.1	10.2		

\*Negligible

Table 2. Power and mass breakdown.

---

### Conclusion

The technologies developed over the last four years at The University of Arizona NASA Space Engineering Research Center are being integrated into the design of the Common Lunar Lander. At this time, a one-half scale model has been constructed and testing is currently underway. Although the current design of the autonomous materials production facility is highly automated, the main focus of this research is to integrate the necessary technologies in such a manner that the completed design is highly reliable and fault tolerant.

### References

Taylor, I. Common lunar lander. Artemis Workshop, February 3-5, 1992.

Ramohalli, K., K. Ousterhout, K.R. Sridhar, and J.M. DiFrancesco. A robotic common lunar lander concept in support of the space exploration initiative. Accepted for presentation at the ASME winter Annual Meeting, Anaheim, California, 1992.

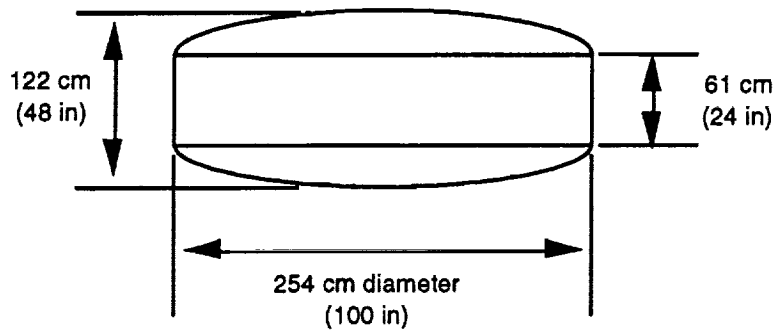

Figure 1. Approximate CLL Payload Dimensions.

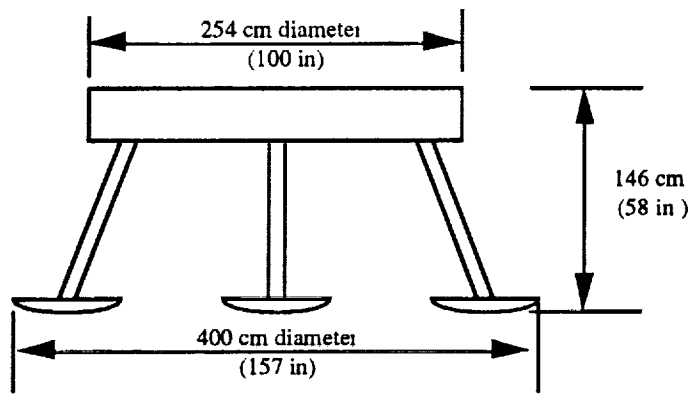

Figure 2. Approximate CLL Dimensions.

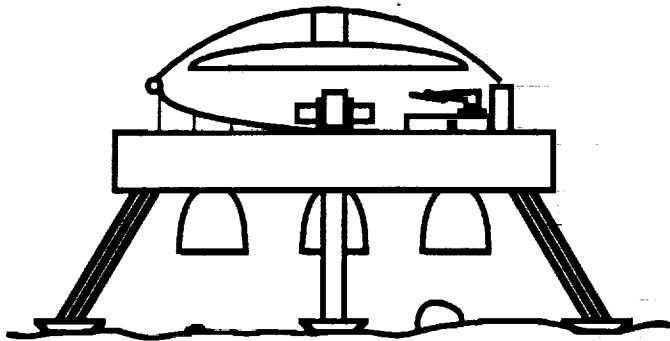

Figure 3. The CLL As Landed - In An Undeployed State.



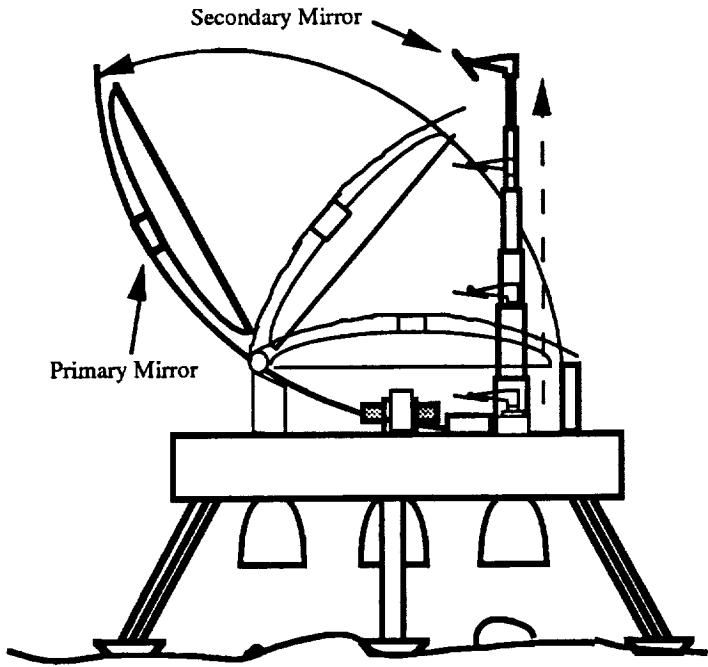

Figure 4. Primary and Secondary Mirrors Deploying.

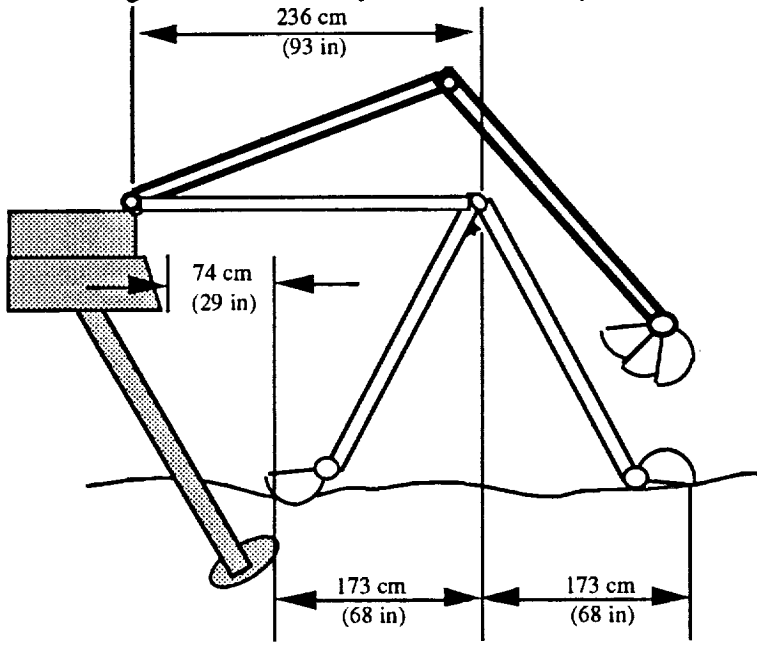

Figure 5. Primary Arm Operating Range.

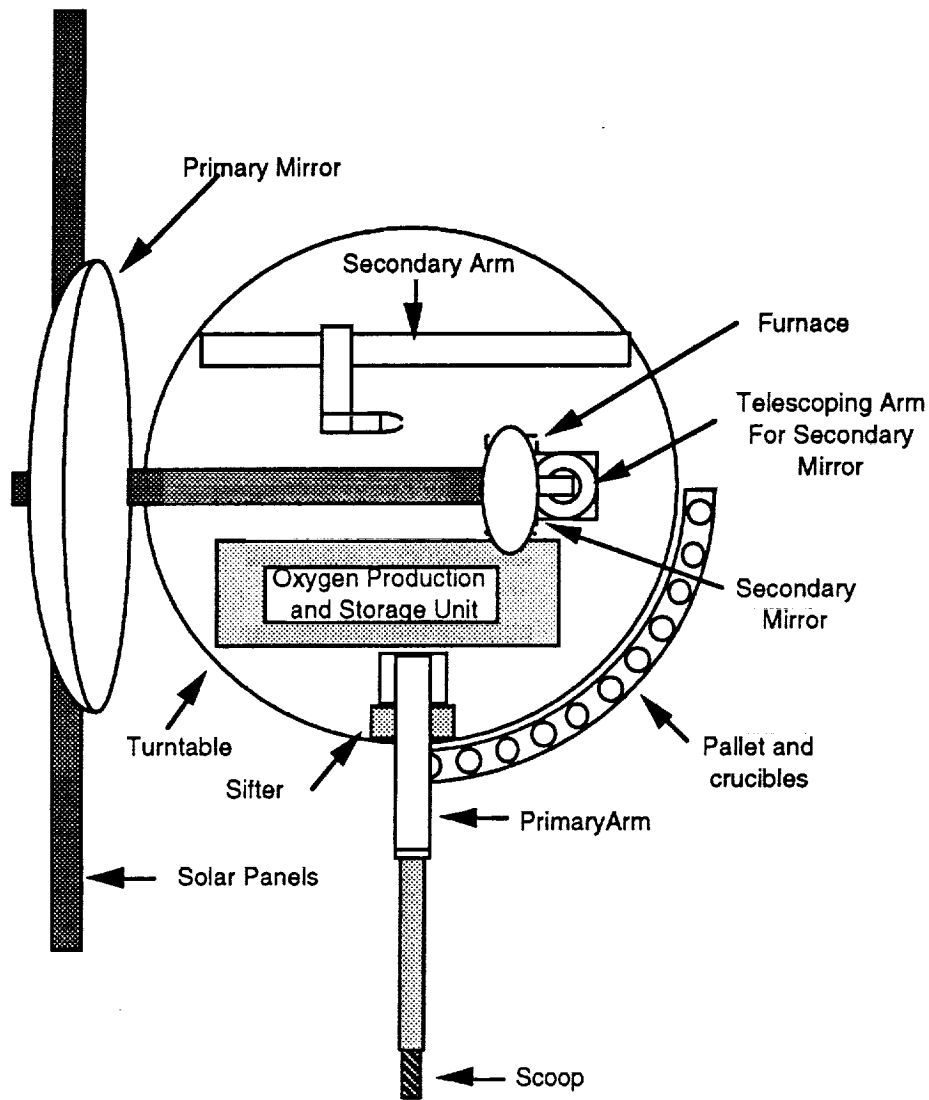

Figure 6. Top View of The Robotic Oxygen Production Facility.