

N93-26925**GENERAL DYNAMICS**
Space Systems Division

Clustered Engine Study Team

Kyle Shepard	Study Manager
Paul Sager	Propulsion
Sid Kusunoki	Vehicle Design
John Porter	Systems Analysis
Al Campion	Mass Properties
Gunnar Mouritzan	Propulsion
Will Glunt	Trajectory/Performance
George Vegter	Guidance and Control
Rob Koontz	Guidance and Control

GENERAL DYNAMICS
Space Systems Division

TABLE OF CONTENTS

Clustered NTR Study Introduction.....	1
Mission Description	6
Reference Vehicle and Engine.....	8
Propulsion System Preliminary Design.....	11
Run Tank Based Systems.....	12
Boost Pump Based Systems.....	21
Systems Analysis.....	31
Summary and Conclusions.....	43

CLUSTERED NTR STUDY INTRODUCTION

CLUSTERED NTR STUDY

GENERAL DYNAMICS
Space Systems Division

OVERVIEW

- Study Introduction
- Mission Description
- Reference Vehicle Design
- Propulsion System
- Systems Analysis
- Summary And Conclusions

KMS 1/7/92

The presentation will cover several topics which together encompass this preliminary assessment of nuclear thermal rocket engine clustering. The study objectives, schedule, flow and groundrules are covered. This is followed by the NASA groundruled mission and our interpretation of the associated operational scenario. The NASA reference vehicle is illustrated, then we zoom in on the four propulsion system options examined in this study. Each propulsion system's preliminary design, fluid systems, operating characteristics, thrust structure, dimensions and mass properties are detailed as well as the associated key propulsion system/vehicle interfaces. A brief series of systems analysis will also be covered including: thrust vector control requirements, engine out possibilities, propulsion system failure modes, surviving system requirements and technology requirements. The presentation concludes with an assessment of vehicle/propulsion system impacts due to the lessons learned in this study.

CLUSTERED NTR STUDY OBJECTIVE

"To develop a top level assessment of the feasibility of clustering Nuclear Thermal Rocket engines."

A NASA reference vehicle and mission scenario were given.

The approach then was to develop four propulsion system designs that could be used as reference configurations for future engineering assessments.

The Study addresses:

- Two and three engine propulsion system designs with either boost pumps or run tanks for engine start up**
- Thrust Vector Control (TVC) Requirements**
- Engine out possibilities**
- Propulsion system Failure modes**
- Technology requirements**

KMS 1/7/92

The objective of the study was to develop propulsion system designs that could be integrated with the provided reference vehicle and fly the provided reference mission. Four propulsion system options were developed using two and three engines with either boost pumps or run tanks for engine start up. Our intent was to develop propulsion systems with a cluster of NTR engines that could be used as reference configurations for future systems optimization. In doing this we considered the following system issues: TVC requirements, Engine out possibilities, propulsion system failure modes and technology development requirements.

STUDY SCHEDULE

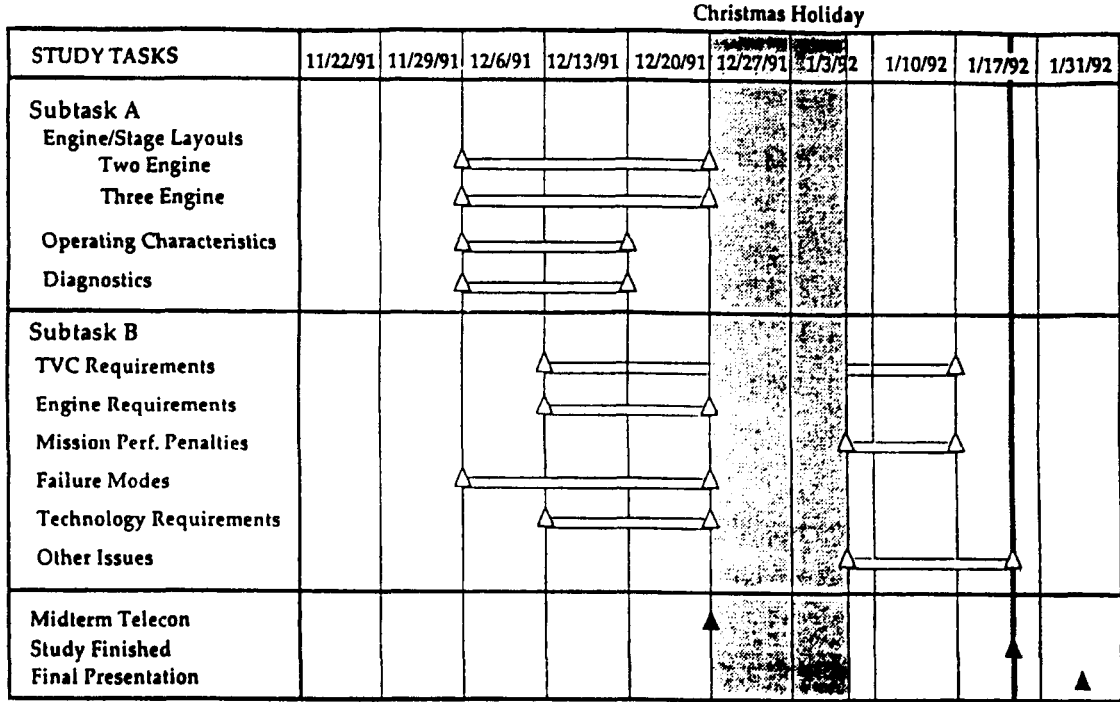

KMS 1/7/92

the study was a five week effort beginning the first week of December 1991, with a christmas holiday in the middle and ending on Jan. 15, 1992. The propulsion system preliminary designs and systems analysis were primarily completed in the first three weeks of the study. The remainder was used for analysis and design iterations as well as presentation preparation.

CLUSTERED ENGINE STUDY FLOW

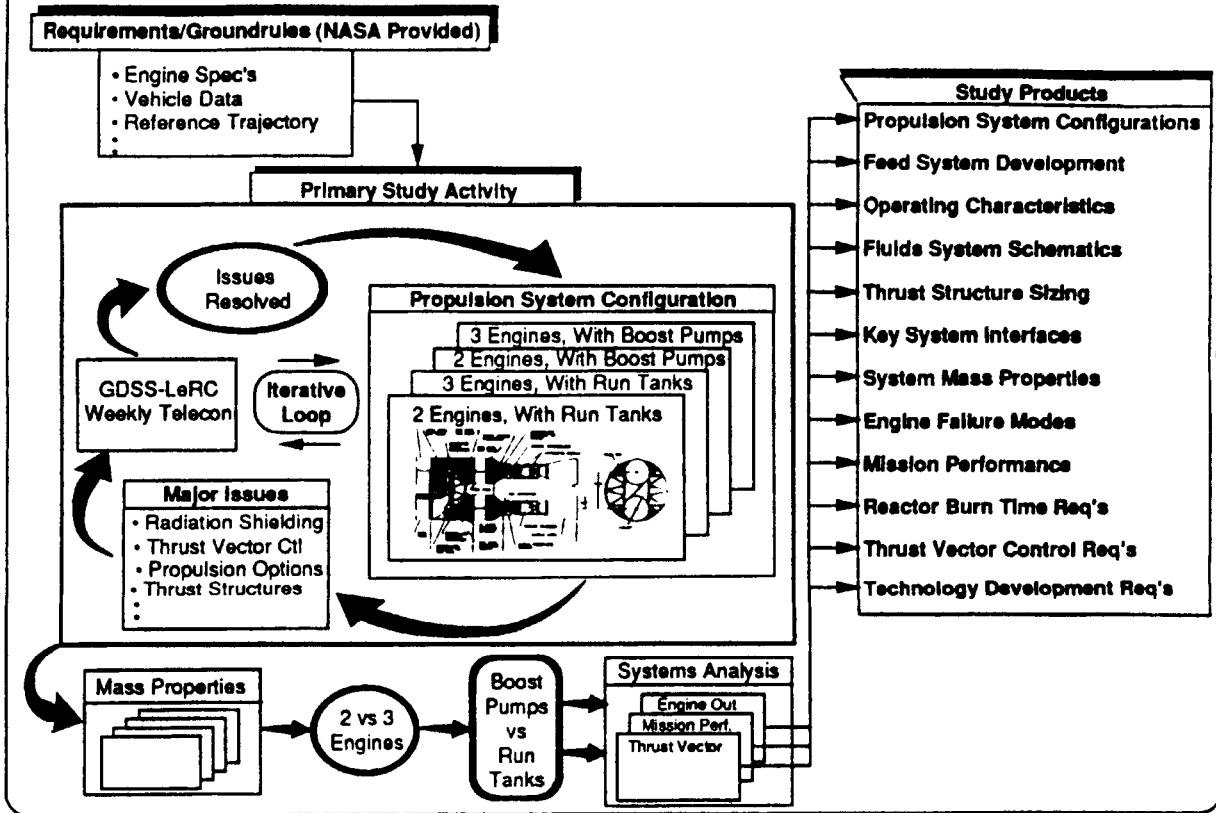

KMS 1/17/92

The study was initiated with a series of NASA LeRC provided groundrules and requirements. These were provided in appendix form and served as the point of departure for the NTP vehicle, mission, engine and propulsion system.

The primary study activity consisted of developing preliminary propulsion system designs for two and three engine propulsion systems with either run tanks or boost pumps for engine start up. As these propulsion systems were developed, several design issues arose. Design issues were addressed at LeRC-GDSS weekly telecons where issues were raised, resolved and the resulting decision(s) were applied to the design work. This iteration process continued throughout the study.

Upon completion of the design phase, mass properties were developed and a series of systems analysis took place. The systems work concentrated on issues relating to the engine out scenario. This analysis allowed us to quantify thrust vector control, reactor burn time and technology requirements as well as assess impacts to the vehicle such as mission performance penalties and failure modes.

MISSION DESCRIPTION

CLUSTERED MTR STUDY

GENERAL DYNAMICS
Space Systems Division

REFERENCE MARS TRAJECTORY

SHORT-DURATION PILOTED MSSION
(2014 Opportunity with Venus Swingby)

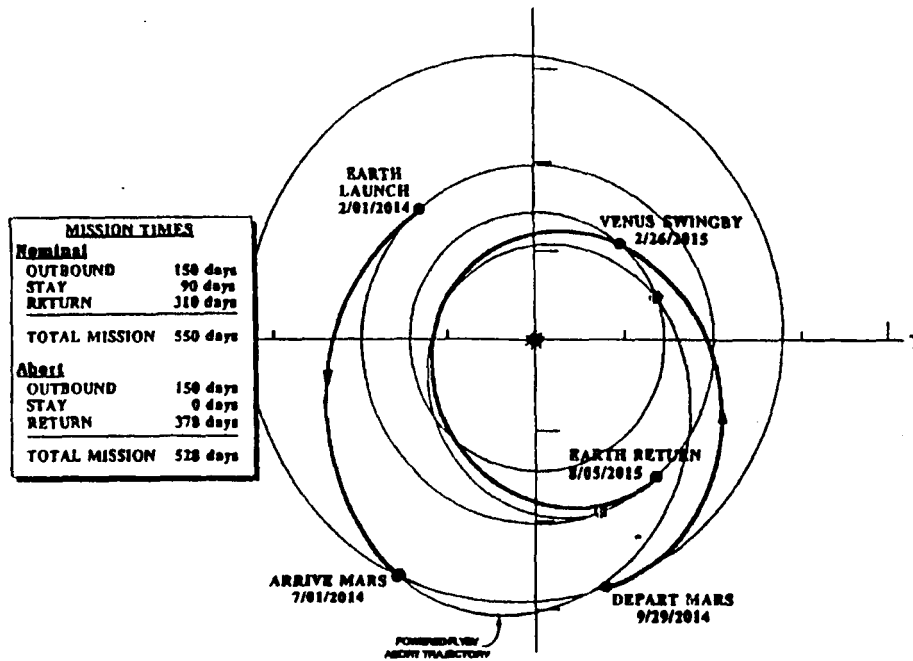

KMS 1/17/02

The reference trajectory is a short opposition type trajectory. It is developed around the 2014 mission opportunity and includes a Venus swingby on Earth return. The outbound leg lasts 150 days and includes three perigee burns for Earth departure. Upon arrival at Mars, the crew performs a surface science mission lasting 90 days. The Earth return leg lasts 310 days and includes a single burn for Mars departure. Note that there is a robust Mars powered flyby abort mode available should a problem occur after Trans Mars Injection (TMI) or before Mars orbit capture (MOC).

TMI, MOC and Trans Earth Injection (TEI) burns were considered in our engine out/mission performance analysis. We consider cases for either 1 or 2 engines out for the boost pump and run tank based propulsion system options.

REFERENCE VEHICLE DESIGN

CLUSTERED NTR STUDY

GENERAL DYNAMICS
Space Systems Division

REFERENCE MARS TRANSFER SYSTEM

2014 NTR-Powered Piloted Mars Vehicle (Modular Design)
"No MEV" Spin/Sprint Mission Mode
(2 - 75 klbf NERVA-Derivative Engine/Composite Fuel/isp=225s)

- Vehicle assessed from core tank aft
- Primary Vehicle Modifications:
 - Core Propellant Tank (For Boost Pump Config's Only)
 - Thrust Structures
 - Run Tanks
 - Reactor Shields
 - Reactors
 - Nozzle Extension

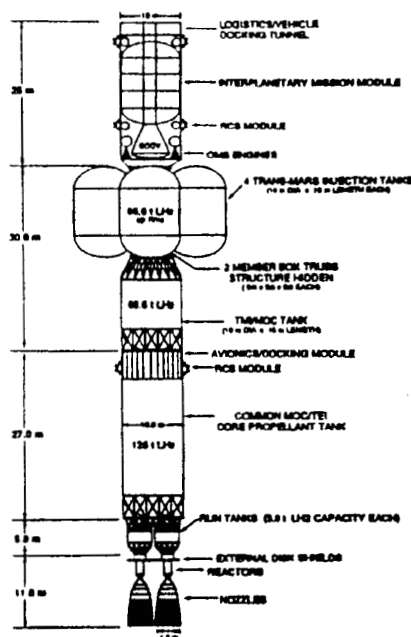

KMS 1/17/92

Our analysis concentrates on the vehicle elements from the core tank and aft. The core propellant tank is resized for the boost pump case. Sizing is based on a combination of a fully integrated propulsion system launch requirement on either STS or Titan IV. This scenario enables a more traditional intertank adapters/thrust structure. In moving from the two to three engine case, the run tanks are re-sized to take advantage of a reduced requirement for propellant volume at start. The reactor shields are modified to remove the center shield section and include a side shields. This is done to reduce shielding mass. The reactors themselves are also reduced in size due to the reduced thrust requirement on the three engine case. Lastly, an engine without a nozzle extension was groundruled.

REFERENCE 75 klbf NERVA ENGINE

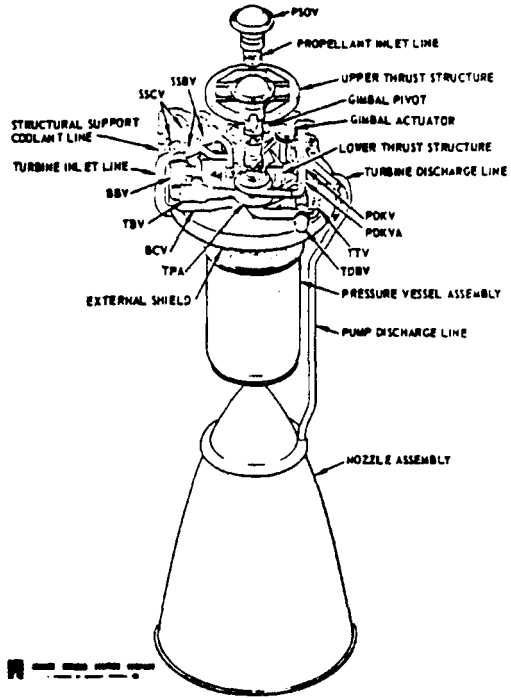

KMS 1/17/92

The reference engine is a NERVA "full flow" concept developed by Altseimer of Aerojet Nuclear Systems Company, circa 1971. It is an engine typical of that era. For the two engine cases, the reference 75 klbf engine was used, the three engine cases utilized a scaled down version of this engine sized at 50 klbf.

PROPULSION SYSTEM PRELIMINARY DESIGN

RUN TANK BASED SYSTEMS

PROPULSION SYSTEM R-2 DESCRIPTION & DIMENSIONS

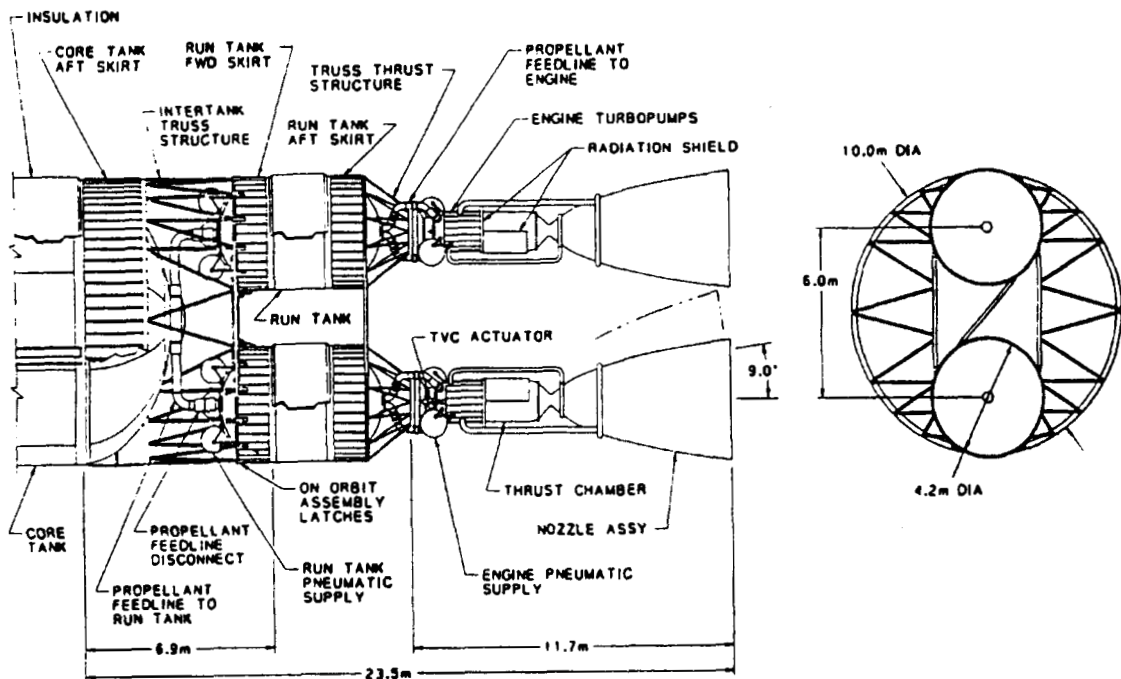

SHK 1/9/82

This configuration utilizes two 75 kbf thrust NERVA nuclear thermal rocket engines with separate run tanks. The run tanks are used to minimize pressurization gas requirements for engine start. Gaseous helium for pressurizing the run tanks is supplied by high pressure bottles located above the run tanks. Once engine start is achieved, hydrogen gas is bled from the engines and used to pressurize the core tank. After the core tank is sufficiently pressurized, propellant from the core tank is fed through the run tanks to continue to feed the engines. At the end of each burn, the run tanks may be filled to capacity to repeat the procedure for the next engine start.

The run tank, engine, and thrust structure combine to form the propulsion module. The propulsion module is launched separately from the rest of the vehicle and is coupled to the core tank on orbit. Fluid system and electrical disconnects and structural latches are provided to allow for on orbit coupling of the propulsion module to the core tank.

An aluminum-lithium (Al-Li) tubular intertank truss structure transfers the thrust from the propulsion modules to the core tank. Lateral Al-Li tubular struts stiffen the structure for gimballed thrust vector loads at the end of the run tank aft skirt. Symmetrical Al-Li tubular truss thrust structures are used to transfer the engine thrust loads to the run tank aft skirts.

The run tanks are spaced to allow the maximum distance between engines possible without exceeding the 10 meter diameter limit. This provides a distance of 6 meters between the engine centers which is more than the 5 meter minimum required to minimize neutronic coupling impacts. This spacing allows one engine to gimbal inboard a maximum of 9 degrees with the other engine in the neutral position. The overall length of this configuration from start of intertank adapter to engine exit is 23.5 meters.

**PROPULSION SYSTEM R-2
Mass Properties**

<u>ITEM</u>	<u>WEIGHT IN POUNDS</u>	
• CLUSTER TANKED WEIGHT		82490
- Structure		9620
- Core Tank Lower Support Structure	4930	
- Run Tank Upper Support Structures (2)	690	
- Run Tanks (2) (Includes Insulation)	2959	
- Run Tank Lower Thrust Structure (2)	1040	
- Feed System		1390
- Feedlines	600	
- Valves	240	
- Disconnects	260	
- Gimbal Joints	210	
- Line Insulation	80	
- Pressurization System		1630
- Helium Bottles	1290	
- Supports	260	
- Lines	80	
- Engine Assemblies (2)		51320
- Engines	31480	
- External Shields	19840	
- Contingency (10%)		960
- Helium		360
- Hydrogen Capacity		17200

KMS-AFC 1/7/92

NASA LeRC NPO/ASAO reference weights were used for the engine, shield and run tank assemblies. Other weight estimates were developed by General Dynamics Space Systems(GDSS) and are estimated from existing Centaur system weights and/or NLS predesign weights. All structural weights were calculated using Aluminum Lithium (Al 2090, $\rho = 0.092 \text{ lb/in}^3$). The trussed adapter utilized 24 truss elements per engine. Intertank and run tank adapters were assumed to be semi-monocoque construction. Machined isogrid adapters could be significantly lighter if no frequency/stiffness problems exist. The intertank adapter will likely have many cutouts for fuel lines and/or access. An additional 25% was added to the basic structural weight in order to account for additional localized structure needed around cutouts. An additional 10% contingency factor was added to the GDSS developed weights. The NASA LeRC NPO/ASAO weights were supplied with contingency included.

PROPULSION SYSTEM R-3 DESCRIPTION & DIMENSIONS

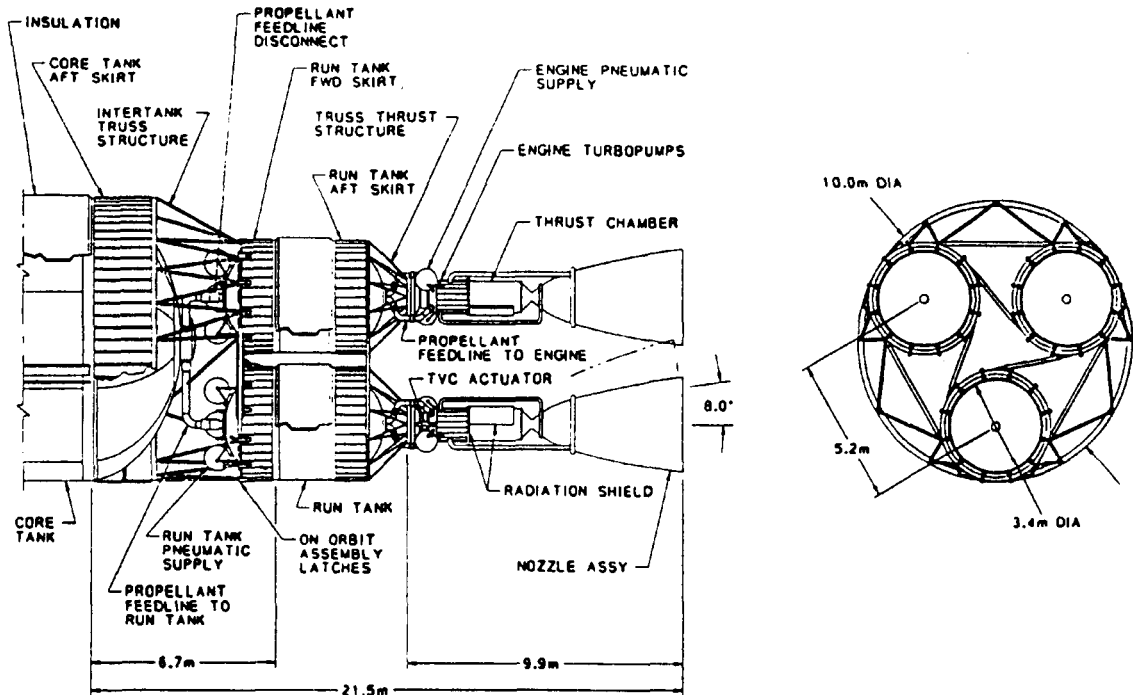

SHK 1/9/92

This configuration utilizes three 50 klb thrust nuclear thermal rocket engines with separate run tanks. The run tanks are used to minimize pressurization gas requirements for engine start. Gaseous helium for pressurizing the run tanks is supplied by high pressure bottles located above the run tanks. Once engine start is achieved, hydrogen gas is bled from the engines and used to pressurize the core tank. After the core tank is sufficiently pressurized, propellant from the core tank is fed through the run tanks to continue to feed the engines. At the end of each burn, the run tanks may be filled to capacity to repeat the procedure for the next engine start.

The run tank, engine, and thrust structure combine to form the propulsion module. The propulsion module is launched separately from the rest of the vehicle and is coupled to the core tank on orbit. Fluid system and electrical disconnects and structural latches are provided to allow for on orbit coupling of the propulsion module to the core tank.

An aluminum-lithium tubular intertank truss structure transfers the thrust from the propulsion modules to the core tank. Lateral Al-Li tubular struts stiffen the structure for gimballed thrust vector loads at the end of the run tank aft skirt. Symmetrical Al-Li tubular truss thrust structures are used to transfer the engine thrust loads to the run tank aft skirts.

The run tanks are spaced to allow the maximum distance between engines possible without exceeding the 10 meter diameter limit. This provides a distance of 5.2 meters between the engine centers which is more than the 5 meter minimum required to minimize neutronic coupling impacts. This spacing allows one engine to gimbal inboard a maximum of 8 degrees with the other engine in the neutral position. The overall length of this configuration from start of intertank adapter to engine exit is 21.5 meters.

**PROPULSION SYSTEM R-3
Mass Properties**

ITEM	WEIGHT IN POUNDS	
• CLUSTER TANKED WEIGHT		99000
- Structure		11760
- Core Tank Lower Support Structure	4850	
- Run Tank Upper Support Structures (3)	970	
- Run Tanks (3) (Includes insulation)	4440	
- Run Tank Lower Thrust Structure (3)	1500	
- Feed System		1560
- Feedlines	700	
- Valves	260	
- Disconnects	290	
- Gimbal Joints	230	
- Line Insulation	80	
- Pressurization System		2440
- Helium Bottles	1930	
- Supports	390	
- Lines	120	
- Engine Assemblies (3)		55780
- Engines	35940	
- External Shields	19840	
- Contingency (10%)		1130
- Helium		530
- Hydrogen Capacity		25800

KMS-AFC 17/92

NASA LeRC NPO/ASAO reference weights were used for the engine, shield and run tank assemblies. Other weight estimates were developed by General Dynamics Space Systems(GDSS) and are estimated from existing Centaur system weights and/or NLS predesign weights. All structural weights were calculated using Aluminum Lithium (Al 2090, $\rho = 0.092 \text{ lb/in}^3$). The trussed adapter utilized 24 truss elements per engine. Intertank and run tank adapters were assumed to be semi-monocoque construction. Machined isogrid adapters could be significantly lighter if no frequency/stiffness problems exist. The intertank adapter will likely have many cutouts for fuel lines and/or access. An additional 25% was added to the basic structural weight in order to account for additional localized structure needed around cutouts. An additional 10% contingency factor was added to the GDSS developed weights. The NASA LeRC NPO/ASAO weights were supplied with contingency included.

PROPULSION SYSTEM R-2 & R-3 Intertank Adapter / Thrust Structure

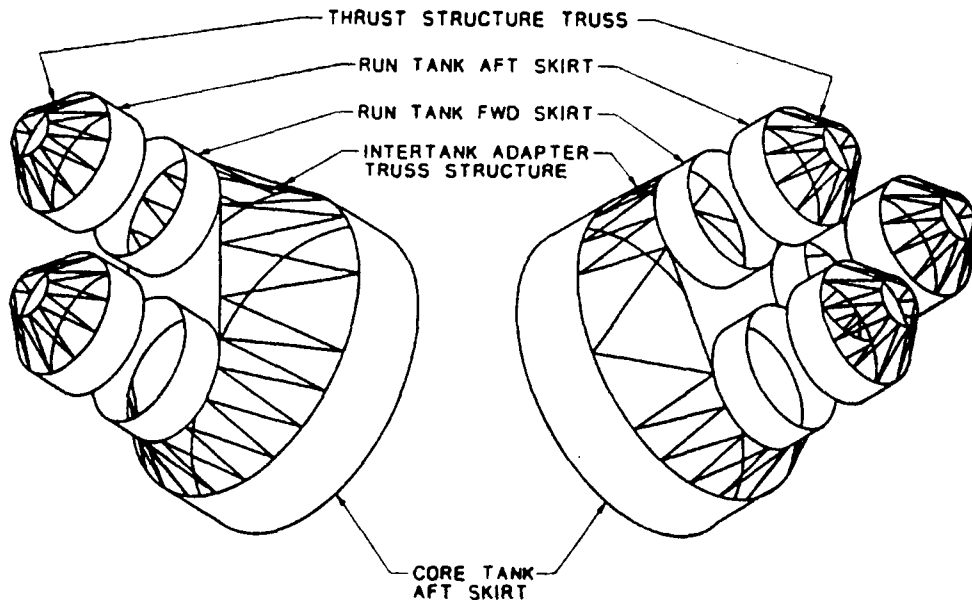

SHK 1/9/92

All the structural components were based on aluminum-lithium construction. Semi-monocoque cylindrical tank skirts were used to be conservative until more stress analysis can be performed. Tubular truss structures were used for part of the engine thrust structure and intertank adapter.

The intertank adapter between the core tank and the run tank consists of the core tank aft skirt, the truss structure, and the run tank forward skirt. The sizing of these structures were based on either launch or flight loads. The core tank aft skirt and the truss structure would be launched with the core tank. Launch loads from the fully loaded core tank would be transferred through the aft skirt and into a payload adapter bypassing the truss structure. Launch accelerations were assumed to be 3.0g axial and 1.5g lateral for a 300 klb type heavy lift launch vehicle. The truss structure would only see engine thrust loads once the vehicle was fully assembled. The run tank forward skirt would be launched with the propulsion module on a Titan IV type launch vehicle. The propulsion module would be launched empty and inverted such that the launch loads would be taken through the run tank forward skirt and into the payload adapter. Launch accelerations for a Titan IV type launch vehicle were assumed to be 2.3g axial and 1.5g lateral.

The thrust structure consists of the run tank aft skirt and truss structure. Both of these structures would also need to withstand the launch loads from a Titan IV type vehicle due to the engine mass since they are all part of the propulsion module.

PROPELLANT FEED AND MAIN ENGINE SYSTEM Two Or Three NTR Engine Cluster With Run Tank

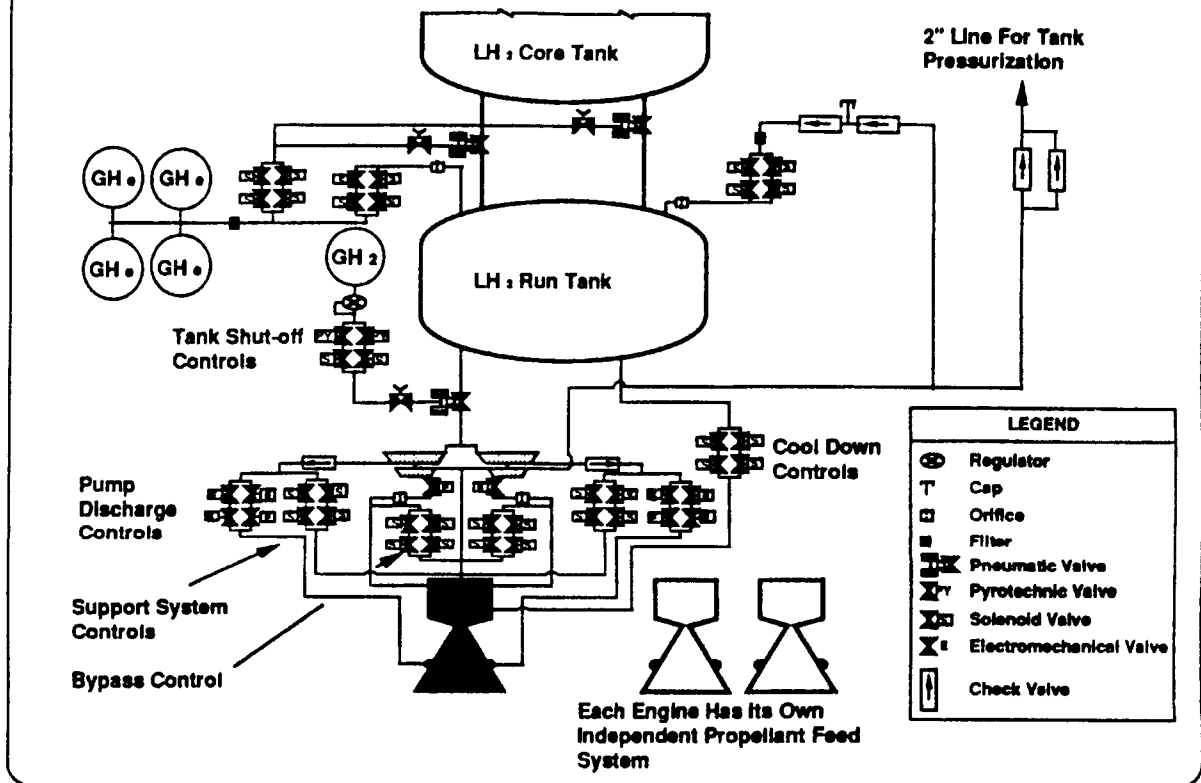

GM01-1/2/92

A propellant feed system with a run tank in addition to the core tank makes it possible to start the propulsion system without pressurizing the core tank first. The smaller volume run tank is pressurized for engine start up. When steady state operation of the engines is established, the core tank is pressurized by autogenous pressurization using hydrogen gas from the turbine outlet. The run tank is then vented enough to allow the tank to be filled with pressurized propellant from the core tank. Two independent main turbopumps were chosen for each engine to guarantee safe engine operation in case of failures in one pump system. The pumps are powered by preheated gaseous hydrogen in an expander cycle arrangement for simplicity and high reliability.

The propellant valves are generally electromechanical. However, due to the large size main propellant feed lines the tank shut-off valves are pneumatically controlled for fast shut-off. The pilot control valves for the pneumatic operated valves are solenoid operated valves. Pyrotechnic valves in the pneumatic system guarantees that the propellant feed system can not be inadvertently opened before the vehicle is ready for operation.

Helium is used for run tank pressurization but an alternative gaseous Hydrogen system could be used with a single 3.5 ft diameter low pressure (300 psia) gas storage bottle that can be continually recharged with hydrogen by feeding liquid Hydrogen from the tank through an electric heater.

Each engine in a two or three engine configuration has its own independent propellant feed system, so that with one engine system out, the mission can be completed with the remaining engine(s).

R2, R3 PROPULSION SYSTEMS Operating Characteristics

	R-2	R-3
START-UP		
THRUST, lbf	0 - 150,000	0 - 150,000
TIME, min	1	1
CORE TANK PRESS., psia	26	26
RUN TANK PRESS., psia	26	26
GIMBAL DISPLACEMENT, degrees	10	6
GIMBAL RATE, degrees/s	5	3
GIMBAL ACCELERATION, degrees/s ²	20	10
STEADY STATE		
THRUST, lbf	58,000 - 150,000	75,000 - 150,000
SPECIFIC IMPULSE, s	925	925
MAXIMUM BURN TIME, min	60	60
CORE TANK PRESS., psia	26 - 40	26 - 40
RUN TANK PRESS., psia	26 - 40	26 - 40
GIMBAL DISPLACEMENT, degrees	10	6
GIMBAL RATE, degrees/s	5	3
GIMBAL ACCELERATION, degrees/s ²	20	10
SHUTDOWN		
THRUST, lbf	150,000 - 380	150,000 - 380
COOLDOWN PULSE FREQUENCY, s ⁻¹	∞ - 0.0001	∞ - 0.0001
CORE TANK PRESS., psia	26 - 40	26 - 40
RUN TANK PRESS., psia	26 - 40	26 - 40
GIMBAL DISPLACEMENT, degrees	10	6
GIMBAL RATE, degrees/s	5	3
GIMBAL ACCELERATION, degrees/s ²	20	10

PHS 1/8/92

Propulsion system operating characteristics were established for the run tank designs for start-up, steady state, and shutdown conditions. For both the 2-engine and 3-engine designs, the total thrust ramps up from 0 to 150,000 pounds in about 1 minute. Assuming a propellant condition of saturation at 16 psia, about 10 psi pressurization is required to provide NPSH to the engine turbopumps and to account for line entrance losses, line losses, and nuclear radiation heating of the propellant during line transit. The gimbaling angular displacements, slew rates, and accelerations were estimated by adding 2 degrees displacement to the gimbaling requirements determined for engine-out events, assuming conditions at the end of start-up.

For steady state, it was assumed that the total thrust could vary from full thrust with all engines operating to an engine-out condition with the active engine(s) throttled to 75 percent thrust. The specific impulse and maximum burn times were assumed to be unchanged from current specifications. For the planned mission, it was estimated that the propellant vapor pressure would rise approximately 14 psi due to nuclear radiation heating of the propellant. The gimbaling requirements are the same as at the end of start-up.

The shutdown thrust reduces to a minimum of 190 pounds for the 75,000 lbf NERVA engines. It was estimated that this minimum requirement would scale linearly for the 50,000 lbf engine. The cooldown pulse rate will vary from steady flow to the frequency required at that condition at the point cooling can be terminated (0.0001). The tank pressures and gimbaling requirements at the start of shutdown would be the same as for steady state.

INTERFACE ELEMENTS FOR RUN TANK DESIGNS

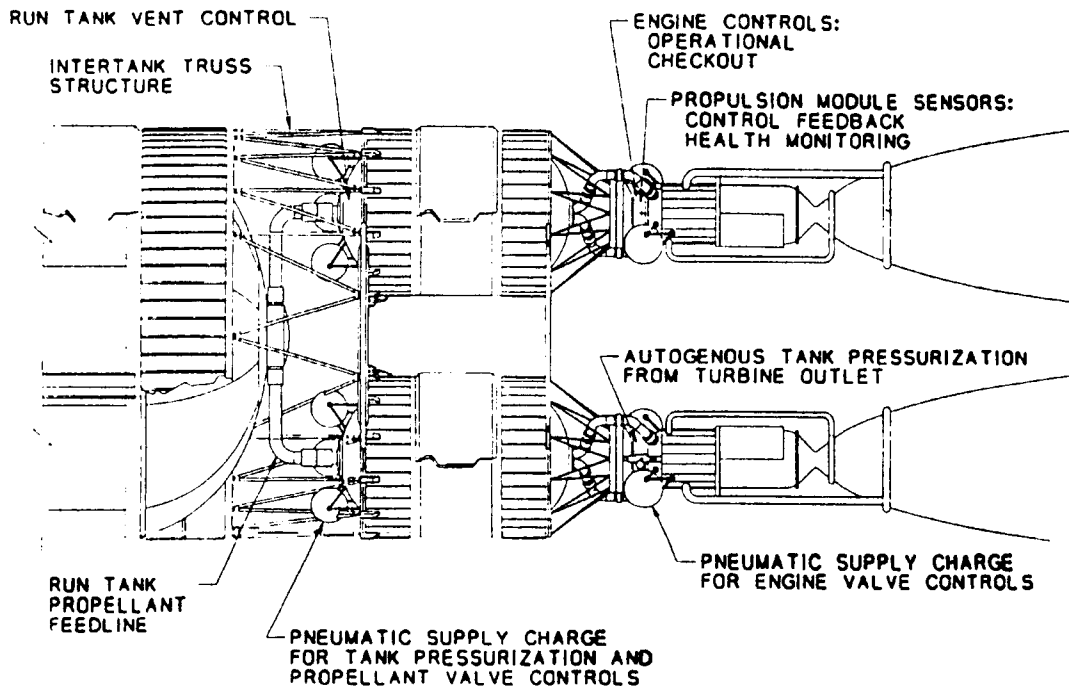

GM04-1/292

The NTR engine interacts with the vehicle and its support systems through the: engine controllers, engine sensors, control feedback loops, vehicle health management systems, thrust structure etc. Each of these interface elements is affected in both design and operation by the propulsion system configuration. The thrust structure for example, is sensitive to propulsion system configuration (Run Tanks vs Boost Pumps, etc.) which affect its design on the ground (for access during integration assembly and checkout) and on orbit (depending on assembly philosophy, assembled vs docked vs modular propulsion system design). The other major consideration in the system interface impacts unique to NTR engine based propulsion systems is the radiation field. The propellant feedlines for example are affected by engine in the traditional manner, but with NTR one must also account for operation in an intense radiation environment (propellant heating in lines). Each of the primary interface elements are subject to optimization to minimize mass while maximizing safety and reliability. These systems together have a significant impact on the vehicles performance and design approach and should be integrated into any propulsion system design effort.

BOOST PUMP BASED SYSTEMS

CLUSTERED NTR STUDY

GENERAL DYNAMICS
Space Systems Division

PROPULSION SYSTEM B-2 DESCRIPTION & DIMENSIONS

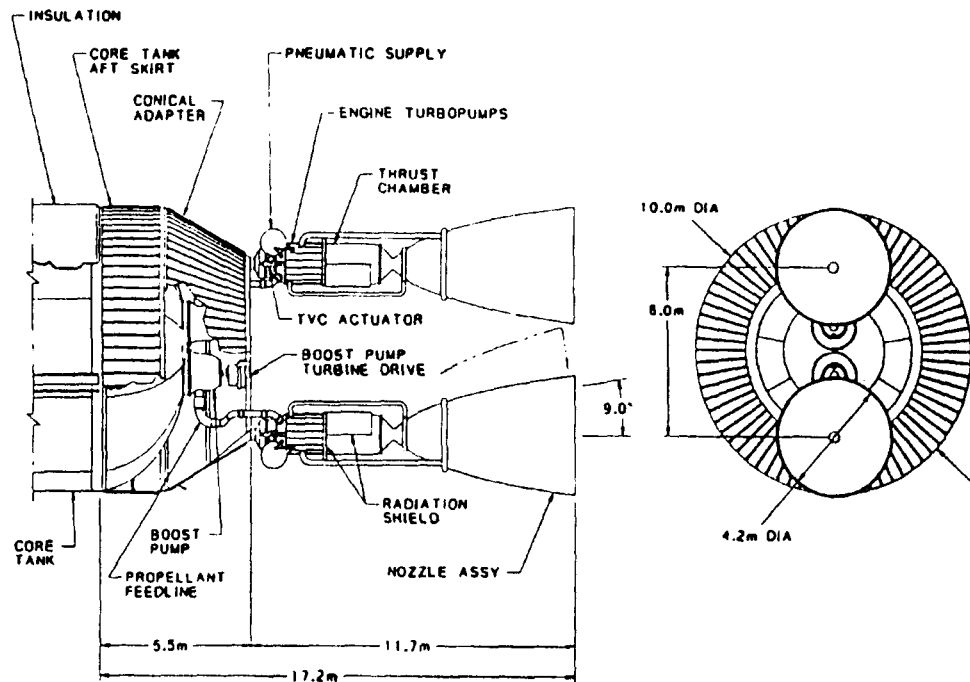

SHK 1/9/92

This configuration utilizes two 75 klb thrust nuclear thermal rocket engines hard-coupled to the core tank. Because of the large ullage volume in the core tank upon restart on some missions, an inordinate amount of pressurization gas would be required to supply the turbopump NPSH for engine restart. Accordingly, the propellant in the core tank is allowed to remain at saturated conditions and boost pumps are used to supply the pressure differential required to provide the NPSH and accommodate the entrance and line losses, as well as the nuclear radiation heating of the propellant as it flows through the line. The boost pumps are powered by turbine drives which run on pressurized gas. Once engine start is achieved, hydrogen gas is bled from the engines and used to run the boost pumps. At the end of each burn the pressurization bottles will be refilled to repeat the procedure for the next engine start.

The core tank, engines, and thrust structure form one unit and are launched together. Due to the fact that this is one unit, the core tank will be shortened by approximately 11.7 meters to accommodate the engines. Extendable nozzles would minimize the launch vehicle shroud volume losses for this configuration. The engine spacing used for this configuration was the same as determined for the run tank version. This provides a distance of 6 meters between the engine centers which is more than the 5 meter minimum required to minimize neutronic coupling impacts. This spacing allows one engine to gimbal inboard a maximum of 9 degrees with the other engine in the neutral position. The overall length of this configuration from start of thrust structure to engine exit is 17.2 meters.

PROPULSION SYSTEM B-2 Mass Properties

<u>ITEM</u>	<u>WEIGHT IN POUNDS</u>	
• CLUSTER TANKED WEIGHT		61230
- Structure		6850
- Core Tank Cylindrical Adapter Structure	3650	
- Conical Thrust Structure	3200	
- Feed System		1450
- Feedlines	240	
- Valves	240	
- Manifolds	30	
- Gimbal Joints	210	
- Line Insulation	30	
- Boost Pumps	700	
- Helium System		580
- Helium Bottles	480	
- Supports	90	
- Lines	10	
- Engine Assemblies (2)		51320
- Engines	31480	
- External Shields	19840	
- Contingency (10%)		890
- Helium		140

AFC 1/8/92

NASA LeRC NPO/ASAO reference weights were used for the engine and shield assemblies. Other weight estimates were developed by General Dynamics Space Systems (GDSS) and are estimated from existing Centaur system weights and/or NLS pre-design weights. All structural weights were calculated using Aluminum Lithium (Al 2090, $\rho = 0.092 \text{ lb/in}^3$). Intertank adapters were assumed to be semi-monocoque construction. Machined isogrid adapters could be significantly lighter if no frequency/stiffness problems exist. The intertank adapter will likely have many cutouts for fuel lines and/or access. An additional 25% was added to the basic structural weight in order to account for additional localized structure needed around cutouts. An additional 10% contingency factor was added to the GDSS developed weights. The NASA LeRC NPO/ASAO weights were supplied with contingency included.

PROPULSION SYSTEM B-3 DESCRIPTION & DIMENSIONS

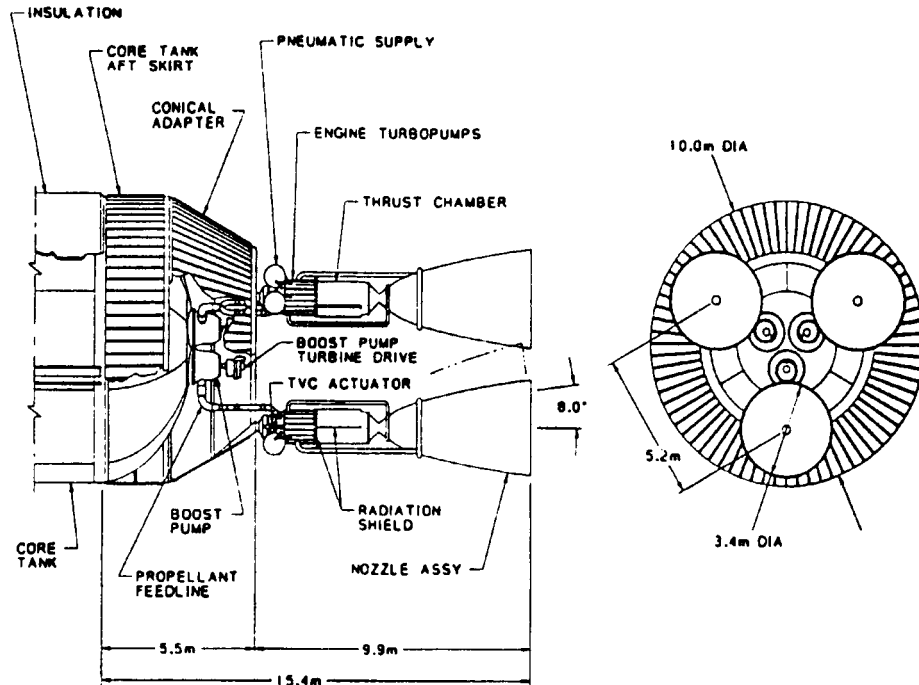

SHK 1/9/92

This configuration utilizes three 50 klb thrust nuclear thermal rocket engines hard-coupled to the core tank. Because of the large ullage volume in the core tank upon restart on some missions, an inordinate amount of pressurization gas would be required to supply the turbopump NPSH for engine restart. Accordingly, the propellant in the core tank is allowed to remain at saturated conditions and boost pumps are used to supply the pressure differential required to provide the NPSH and accommodate the entrance and line losses, as well as the nuclear radiation heating of the propellant as it flows through the line. The boost pumps are powered by turbine drives which run on pressurized gas. Once engine start is achieved, hydrogen gas is bled from the engines and used to run the boost pumps. At the end of each burn the pressurization bottles will be refilled to repeat the procedure for the next engine start.

The core tank, engines, and thrust structure form one unit and are launched together. Due to the fact that this is one unit, the core tank will be shortened by approximately 9.9 meters to accommodate the engines. The engine spacing used for this configuration was the same as determined for the run tank version. This provides a distance of 5.2 meters between the engine centers which is more than the 5 meters required to minimize neutronic coupling impacts. This spacing allows one engine to gimbal inboard a maximum of 8 degrees with the other engine in the neutral position. The overall length of this configuration from start of thrust structure to engine exit is 15.4 meters.

PROPULSION SYSTEM B-3 Mass Properties

ITEM	WEIGHT IN POUNDS	
• CLUSTER TANKED WEIGHT		66620
- Structure		6850
- Core Tank Cylindrical Adapter Structure	3650	
- Conical Thrust Structure	3200	
- Feed System		1910
- Feedlines	470	
- Valves	260	
- Manifolds	20	
- Gimbal Joints	230	
- Line Insulation	30	
- Boost Pumps	900	
- Helium System		900
- Helium Bottles	730	
- Supports	150	
- Lines	20	
- Engine Assemblies (3)		55780
- Engines	35940	
- External Shields	19840	
- Contingency (10%)		970
- Helium		210

AFC 1/8/92

NASA LeRC NPO/ASAO reference weights were used for the engine and shield assemblies. Other weight estimates were developed by General Dynamics Space Systems (GDSS) and are estimated from existing Centaur system weights and/or NLS pre-design weights. All structural weights were calculated using Aluminum Lithium (Al 2090, $\rho = 0.092 \text{ lb/in}^3$). Intertank adapters were assumed to be semi-monocoque construction. Machined isogrid adapters could be significantly lighter if no frequency/stiffness problems exist. The intertank adapter will likely have many cutouts for fuel lines and/or access. An additional 25% was added to the basic structural weight in order to account for additional localized structure needed around cutouts. An additional 10% contingency factor was added to the GDSS developed weights. The NASA LeRC NPO/ASAO weights were supplied with contingency included.

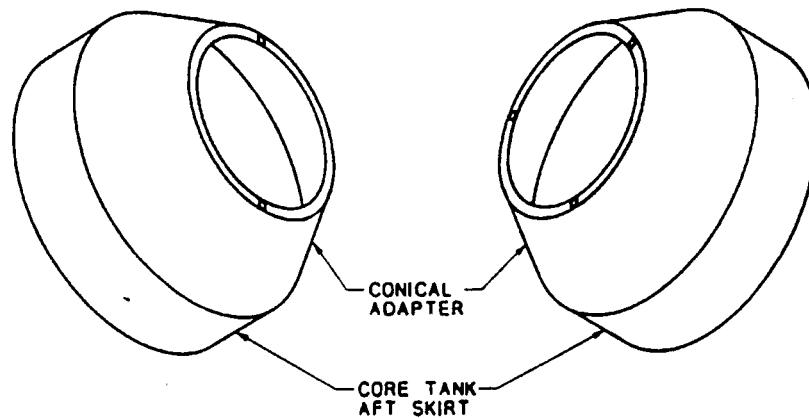
**PROPULSION SYSTEM B-2 & B-3
THRUST STRUCTURE**

SHK 1/9/92

All the structural components were based on aluminum-lithium construction. To be conservative semi-monocoque structures were used for the core tank aft skirt and conical adapter until more stress analysis can be performed.

The thrust structure consists of the core tank aft skirt and the conical adapter. The sizing of these structures was based on launch loads. For the hard-coupled propulsion system design, the core tank aft skirt, conical adapter, and engines would be launched fully assembled to the core tank. Launch loads from the fully loaded core tank would be transferred through the aft skirt and into a payload adapter bypassing the conical adapter. The conical adapter would have to transfer launch loads from the engine mass into the payload adapter. Launch accelerations were assumed to be 3.0g axial and 1.5g lateral for a 300 klb type heavy lift launch vehicle.

PROPELLANT FEED AND MAIN ENGINE SYSTEM
Two Or Three NTR Engine Cluster With Boost Pumps

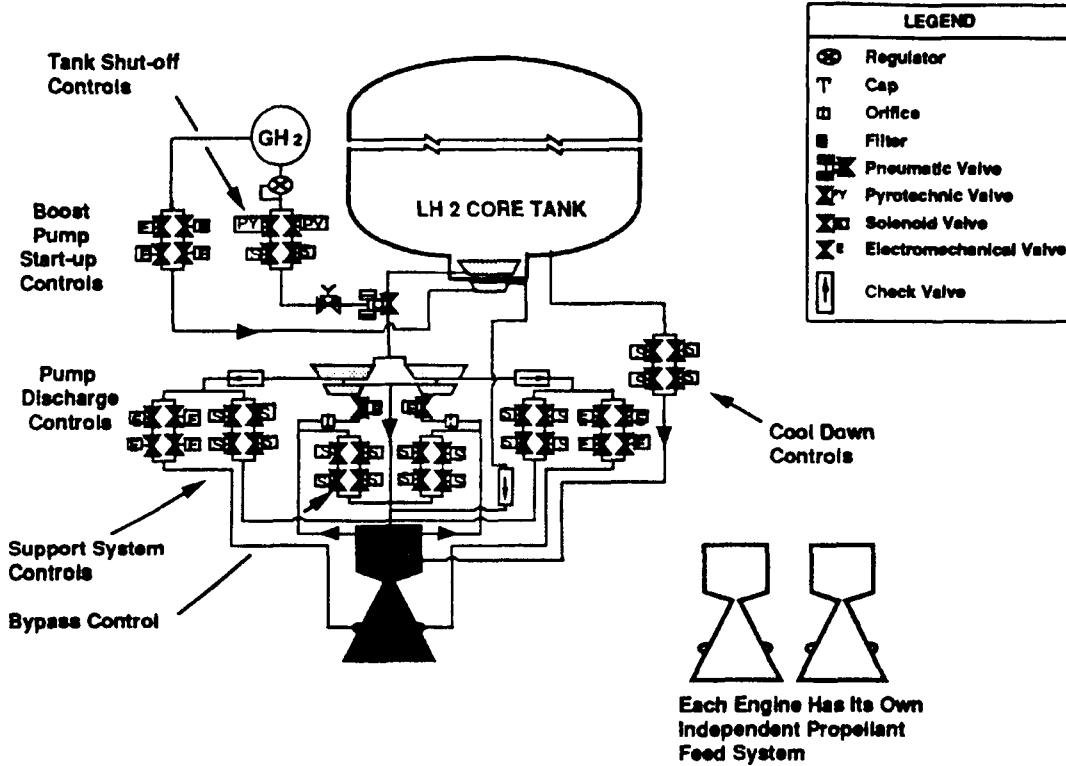

GM01-1/2/92

A propellant feed system with boost pumps guarantees a sufficiently high net positive suction head at the propellant inlet to the main engine pumps without tank pressurization. The boost pumps are started by gaseous hydrogen from a storage bottle to initiate rotation of the boostpump turbine drive. Once the engine turbopump head is established, gaseous hydrogen is fed back from the engine cooling jacket outlet to bootstrap the propulsion system propellant head. Two independent main turbopumps were chosen for each engine to guarantee safe engine operation in case of failures in one pump system. The pumps are powered by preheated gaseous hydrogen in an expander cycle arrangement for simplicity and high reliability.

The propellant valves are generally electromechanical. Due to the large size propellant lines and requirements for fast shut-off the main tank shut-off valve is pneumatically controlled.

Gaseous hydrogen is used for the pneumatic control because it can operate with a single 3.5 ft diameter low pressure (300 psia) gas storage bottle that can be continually recharged with hydrogen by feeding liquid hydrogen from the tank through an electric heater or gaseous hydrogen from the engine during engine operation. This bottle can also be used for restart of the boost pump.

Each engine in a two or three engine configuration as shown has its own independent propellant feed system; however, other options are possible.

PROPULSION SYSTEM OPERATING CHARACTERISTICS - B-2,3

	B-2	B-3
START-UP		
THRUST, lbf	0 - 150,000	0 - 150,000
TIME, min	1	1
CORE TANK PRESS., psia	16	16
GIMBAL DISPLACEMENT, degrees	12	8
GIMBAL RATE, degrees/s	6	4
GIMBAL ACCELERATION, degrees/s ²	25	15
BOOST PUMP DELTA P, psid	10	10
STEADY STATE		
THRUST, lbf	58,000 - 150,000	75,000 - 150,000
SPECIFIC IMPULSE, s	925	925
MAXIMUM BURN TIME, min	60	60
CORE TANK PRESS., psia	16-40	16-40
GIMBAL DISPLACEMENT, degrees	12	8
GIMBAL RATE, degrees/s	6	4
GIMBAL ACCELERATION, degrees/s ²	25	15
BOOST PUMP DELTA P, psid	10	10
SHUTDOWN		
THRUST, lbf	150,000-380	150,000-380
COOLDOWN PULSE FREQUENCY, s ⁻¹	$\infty - 0.0001$	$\infty - 0.0001$
CORE TANK PRESS., psia	16-40	16-40
GIMBAL DISPLACEMENT, degrees	12	8
GIMBAL RATE, degrees/s	6	4
GIMBAL ACCELERATION, degrees/s ²	25	15
BOOST PUMP DELTA P, psid	10	10

PHS 1/8/92

The propulsion system operating characteristics were established for start-up, steady state, and shutdown conditions. For both the 2-engine and 3-engine designs, the total thrust ramps from 0 to 150,000 pounds in about 1 minute. Assuming a propellant condition of saturation at 16 psia, the boost pump provides an additional 10 psid to provide NPSH to the engine turbopumps and to account for line entrance losses, line losses, and nuclear radiation heating of the propellant during line transit. The gimbaling angular displacements, slew rates, and accelerations were estimated by adding 2 degrees displacement to the gimbaling requirements determined for the run tank designs with engine-out events and an additional 2 degrees to account for the reduced displacement of the engines from the c.g. for the boost pump vehicle designs.

For steady state, it was assumed that the total thrust could vary from full thrust with all engines operating to an engine-out condition with the active engine(s) throttled to 75 percent thrust. The specific impulse and maximum burn times were assumed to be unchanged from current specifications. For the planned mission, it was estimated that the shield could be designed to allow the propellant vapor pressure to rise approximately 24 psi due to nuclear radiation heating of the propellant. The gimbaling requirements are the same as at the end of start-up.

The shutdown thrust reduces to a minimum of 190 pounds for the 75,000 lbf NERVA engines. It was estimated that this minimum requirement would scale linearly for the 50,000 lbf engine. The cooldown pulse rate will vary from steady flow to the frequency required at that condition at the point cooling can be terminated (0.0001). The tank pressures and gimbaling requirements at the start of shutdown would be the same as for steady state.

INTERFACE ELEMENTS FOR BOOST PUMP DESIGNS

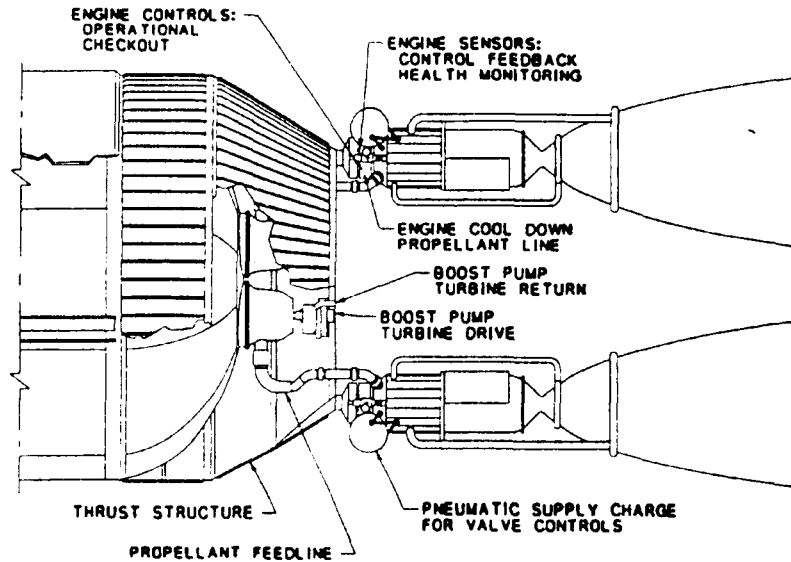

GM04-1/292

The NTR engine interacts with the vehicle and its support systems through the: boost pump turbine drive, boost pump turbine return, engine controllers, engine sensors, control feedback loops, vehicle health management systems, thrust structure etc. Each of these interface elements is affected in both design and operation by the propulsion system configuration. The thrust structure for example, is sensitive to propulsion system configuration (Run Tanks vs Boost Pumps, etc.) which affect its design on the ground (for access during integration assembly and checkout) and on orbit (depending on assembly philosophy, assembled vs docked vs modular propulsion system design). The other major consideration in the system interface impacts unique to NTR engine based propulsion systems is the radiation field. The propellant feedlines for example are affected by engine in the traditional manner, but with NTR one must also account for operation in an intense radiation environment(propellant heating in lines). Each of the primary interface elements are subject to optimization to minimize mass while maximizing safety and reliability. These systems together have a significant impact on the vehicles performance and design approach and should be integrated into any propulsion system design effort.

PROPULSION SYSTEM COMPARISON

	MISSION PERFORMANCE	MISSION RELIABILITY	MISSION OPERATIONS	ENGINE DEVELOPMENT COST	ENGINE DEVELOPMENT SCHEDULE
<u>RUN TANK DESIGN</u>					
2 ENGINE CLUSTER	+				
3 ENGINE CLUSTER		+		+	+
<u>BOOST PUMP DESIGN</u>					
2 ENGINE CLUSTER	+		+		
3 ENGINE CLUSTER	+	+	+	+	+

PHS 1/10/92

A qualitative assessment was made to compare the 4 different engine cluster configurations studied. Some performance advantage can be attributed to the 2-engine cluster designs because the higher thrust engines (75,000 lb) have a somewhat better thrust-to-weight ratio. Also, the boost pump design should be somewhat less weight than the run tank design because less structure is required.

The 3-engine installations provide significantly higher mission reliability, since it would be possible to continue a mission even after the failure of one engine. The mission would have to be aborted if only 1 engine survives, as would be the case for a 2-engine installation.

The mission operations are simplified with a boost pump, since the engine can be started at any time, whereas the run tanks have to be topped-off before restarting the vehicle with a run tank. Also, the complication of changing over to a core tank supply after start is eliminated with the boost pump design.

The run tank design has somewhat more complicated on-orbit coupling operations due to the necessity of coupling the individual propulsion modules to the aft core tank. With the boost tank design, the engines are hard connected to the aft core tank.

Since the 2-engine cluster designs require higher thrust than the 3-engine designs, the development costs will be higher and the development schedule somewhat longer. A major consideration is the cost of the ground test facilities, which is a function of engine size.

While a weighted scoring was not attempted, it appears that the boost pump design is a somewhat better choice than the run tank design. A 3-engine cluster design appears to be a much better design choice than a 2-engine.

SYSTEMS ANALYSIS

CLUSTERED NTR STUDY

GENERAL DYNAMICS
Space Systems Division

SYSTEMS ANALYSIS - OBJECTIVES:

- Identify Engine-Out Impacts on Propulsion Module and Vehicle
- Define/Modify Propulsion System Requirements to Accommodate Engine-Out (RID's)
- Identify Propulsion Module Technology Requirements

JWP 1/8/92

This section examines the impacts of engine out, documents requirements on the engine and vehicle to survive the event, and identifies new propulsion module technology needs.

Our analyses defines mission phases where failures could occur. Thrust vector control requirements to correct for an engine-out condition in both two and three engine configurations are given. Mission performance penalties, in terms of ΔV and additional propellant required to abort, is assessed. Propulsion system failure causes, symptoms, and remedies are examined. The requirements on the surviving propulsion module are defined, and vehicle impacts are discussed. Propulsion module technology requirements are defined, and suggested additions or modifications to the propulsion system baseline are summarized.

ENGINE-OUT MISSION PERFORMANCE IMPACTS

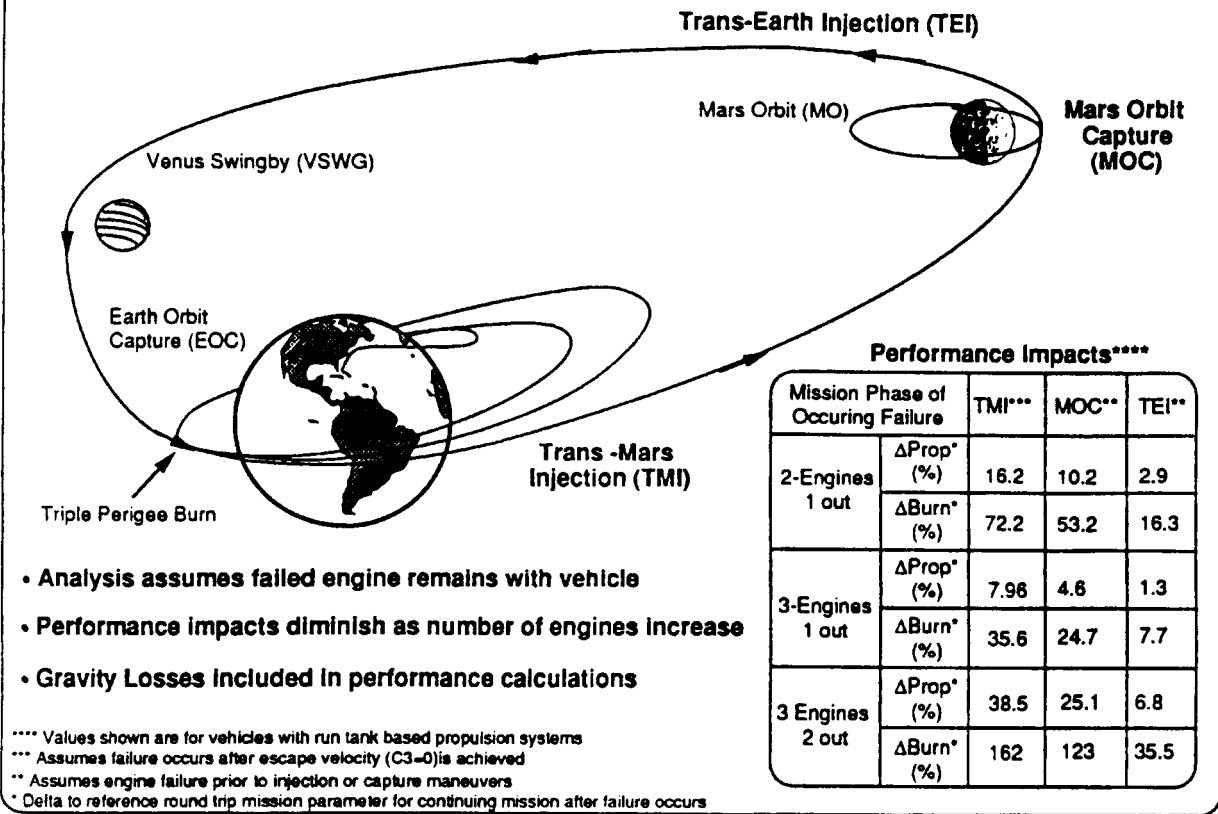

A Mars Transfer System (MTS) with multiple nuclear thermal rocket engines departs from earth parking orbit on 150-day trip to Mars. The MTS captures at Mars for 90-day stay, then leaves Mars on 310-day return, performing a Venus swingby enroute. The MTS then captures into earth parking orbit.

Main engine failure can occur at any of three mission phases: TMI, MOC, or TEI. During TMI the main engines are utilized for a triple perigee departure burn from Earth parking orbit. Main engines are used again for MOC. The TEI burn is initiated after the 90-day stay on the surface. The failed nuclear thermal rocket engine(s) remains with the vehicle during the entire mission duration.

Our analysis assesses performance impacts due to engine out by calculating relative additional propellant mass and reactor burn time delta's to complete the reference mission on time. For the reference mission, total propellant used was approximately 1,036,000 lbs, while nominal reactor burn time is approximately 1.76 hrs.

The amount of additional propellant required to compensate for engine-out depends on which phase of the mission it occurs. For the TMI phase, full thrust is maintained until escape velocity is reached, then the engine-out condition occurs. For the other two mission phases, engine failure occurs prior the injection or capture maneuvers.

The three engine case affords the least impact for a single engine-out condition. A factor of 2.0 - 2.2 less additional propellant and reactor burn time is required relative to the two-engine case. For two and three engine cases, propellant and burn time impacts are greatly reduced for MOC and TEI failures relative to TMI. This is a result of the reduced gravity well at Mars (.38 of Earth's).

The vehicle with a boost pump based propulsion system was also analyzed. Its Δ propellant and Δ burn times were 8% and 3% lower respectively than the run tank case.

PROPULSION SYSTEM FAILURE MODE ANALYSIS

NTR Engine System With Runtank	Problem	Impact	Symptoms	Diagnostics	Remedy
PROPELLANT SUPPLY SYSTEM					
<ul style="list-style-type: none"> CONTROL BRANCHES CORE / RUN TANK PROP. CONTROL VLVS. RUN TANK PRESSURIZATION VLVS. MAIN PROPELLANT START-UP CTL. VLVS RUN TANK VENT CTL. VLVS 	2 Branches Fail	No Or Uncontrolled Flow	Press. Off Nominal	Pressure	Abort
	Low NPSH	Flow Instability	Pressure Fluctuation	Runtank Pressure Pressure	Temporary Reduced Startup Thrust Abort
<ul style="list-style-type: none"> GAS STORAGE AUTOGENOUS TANK PRESSURIZATION 	2 Branches Fail	No Or Uncontrolled Flow	Press. Off Nominal	Runtank Pressure	Reduce Thrust
	Boiling Instability	Flow Instability	Pressure Fluctuation	Runtank Pressure	Shut Down Engine And Abort
<ul style="list-style-type: none"> THRUST VECTOR CONTROL SYSTEM TVC ACTUATORS (EMA) CONTROLLER (EMA) 	Loss Power	Slow Ctl. Response	Parameter Response Vs Command Monitor	Current Degree / Sec Voltage Indicator	Shut Down One Engine Affected
	Loss Signal	Loss Control			Shut Down One Engine Affected
<ul style="list-style-type: none"> MAIN ENGINE ENGINE CONTROLLER CONTROL BRANCHES PUMP DISCHARGE CTL. VLVS PUMP BYPASS CTL. VLVS. TURBINE BYPASS CTL. VLVS. COOLDOWN CTL. VLVS. TURBOPUMP (ONE OF TWO) THRUST CHAMBER REACTOR CONTROL DRUM REACTOR PRESSURE VESSEL NOZZLE / GASIFIER HX. 	Bad Signal	Loss Control	T&P Variation	T and P	Shutdown/Jettison
	2 Branches Fail Closed	Loss Of Flow	Reduced P Or Flow Loss	Valve Position Indicator	Shut Down 1 Pump (Reduce Thrust)
	Loss Regulation	Loss Of Flow	Reduced P	P, Flow., Vlv. Pos.	Shutdown/Jettison
	↓	Loss of P Ctl.	Reduced P	P, Flow., Vlv. Pos.	Shutdown/Jettison
	Loss of reactor	Loss of reactor	Vap. Fuel Elem.	Lo flow, Hi reactor	Shutdown/Jettison
	Bearings Or Blades Fail	Reduced Or No Flow	Pressure Loss	Flowmeter Pressure	Shut Down Pump (Eng. Thrust Reduc.)
	No Coolant	Core Melt Exhausted	Hi Temp.	Temp.	Shutdown/Jettison
	Fail To Rotate	Loss Power Control	Hi Temp.	Temp.	Apply Back-up Control
	Overheat	Fracture	Hi T's And P's	T And P	Shutdown/Jettison
	OVERHEAT	FRACTURE	Hi T's AND P's	T AND P	Shutdown/Jettison

GM09-08/01/92

The above table summarizes the most serious problems that can occur for a nuclear propulsion system with a run tank; however, although they are also the least likely to occur. Many small failures can occur in the support systems undetected and without having any impact on the operation of the propulsion system because of the redundancy and safety features built into the systems. In most cases reduced thrust or safe abort is possible.

The propulsion system includes not only the main engine hardware, but also integrated support systems containing numerous valves, electrical switches, regulators, high pressure gas storage systems, etc, all of which are carefully chosen for specific functions and arranged in multiple combinations to guarantee safe, reliable and accurately controlled operation of the overall propulsion system. Problems associated with the propulsion system is therefore not only related to the main hardware components but also to the many components of the integrated support systems. Problems and failures in the overall system are most often related to the support systems and are detected by instrumentation and behavior of the support systems.

Problems and failures in NTR systems are related mostly to the systems and components which are similar to conventional chemical rockets, which makes it easier to analyze the NTR systems based on past experience. With failures in the reactor, it may be possible to continue safe operation at reduced power for even extended periods of time, since reactor life is greatly increased at reduced power.

Where practical, electromagnetic valves and actuators were chosen for high reliability and fast response. Electromagnetic hardware has been demonstrated to be better performing than pneumatic or hydraulic systems in many applications. Problem areas are mostly related to the controllers in the system which therefore require a large degree of redundancy built into the control systems.

PROPULSION SYSTEM FAILURE MODE ANALYSIS

NTR Engine Syst. With Boost Pump	Problem	Impact	Symptoms	Diagnostics	Remedy
PROPELLANT SUPPLY SYSTEM					
<ul style="list-style-type: none"> CONTROL BRANCHES BOOST PUMP START-UP CONTROL VALVES MAIN PROPELLANT START-UP CONTROL VALVES GAS STORAGE 	2 Branches Fail Low NPSH Lose Pressure	No Or Uncontrolled Flow Flow Instability Abort Mission	Pressure Off Nominal Pressure Fluctuation Pressure Low	Pressure Core Tank Pressure Pressure	Shut Down Pump W. P Out Of Bound Reduce Thrust Shut Down Engine And Abort
THRUST VECTOR CONTROL SYSTEM					
<ul style="list-style-type: none"> TVC ACTUATORS (EMA) CONTROLLER (EMA) 	Lose Power Lose Signal	Slow Control Response Lose Control	Parameter Response Vs Command Monitor	Current Degree / Sec Voltage Indicator	Shut Down One Engine Affected Shut Down One Engine Affected
<ul style="list-style-type: none"> MAIN ENGINE ENGINE CONTROLLER CONTROL BRANCHES PUMP DISCHARGE CTL. VLVS PUMP BYPASS CTL. VLVS. TURBINE BYPASS CTL. VLVS. COOLDOWN CTL. VLVS. TURBOPUMP (ONE OF TWO) THRUST CHAMBER REACTOR CONTROL DRUM REACTOR PRESSURE VESSEL NOZZLE / GASIFIER HX. 	Bad Signal 2 Branches Fail Closed Lose Regulator ↓ Bearings Or Blades Fail No Coolant Fail To Rotate Overheat Overheat	Lose Control Loss Of Flow Loss Of Flow Loss of P Cil. Loss of reactor Reduced Or No Flow Core Melt Exhausted Lose Power Control Fracture Fracture	T&P Variation Reduced P Or Flow Loss Reduced P Reduced P Vap. Fuel Elem Pressure Loss Hi Temp. Hi Temp. Hi T's And P's HI T's AND P's	T and P Valve Position Indicator P, Flow., Vlv. Pos. P, Flow., Vlv. Pos. Lo flow, Hi reactor Flowmeter Pressure Temp. Temp. T And P T AND P	Shutdown/Jettison Shut Down 1 Pump (Reduce Thrust) Shutdown/Jettison Shutdown/Jettison Shutdown/Jettison Shut Down Pump (Eng. Thrust Reduc.) Shutdown/Jettison Apply Back-up Control Shutdown/Jettison Shutdown/Jettison

GM08-0801/92

The above table summarizes the most serious problems that can occur for a nuclear propulsion system with a boost pump; however, they are also the least likely to occur. Many small failures can occur in the support systems undetected and without having any impact on the operation of the propulsion system because of the redundancy and safety features built into the systems. In most cases reduced thrust or safe abort is possible.

The propulsion system includes not only the main engine hardware, but also integrated support systems containing numerous valves, electrical switches, regulators, high pressure gas storage systems, etc, all of which are carefully chosen for specific functions and arranged in multiple combinations to guarantee safe, reliable and accurately controlled operation of the overall propulsion system. Problems associated with the propulsion system is therefore not only related to the main hardware components but also to the many components of the integrated support systems. Problems and failures in the overall system are most often related to the support systems and are detected by instrumentation and behavior of the support systems.

Problems and failures in NTR systems are related mostly to the systems and components which are similar to conventional chemical rockets, which makes it easier to analyze the NTR systems based on past experience. With failures in the reactor, it may be possible to continue safe operation at reduced power for even extended periods of time, since reactor life is greatly increased at reduced power.

Where practical, electromagnetic valves and actuators were chosen for high reliability and fast response. Electromagnetic hardware has been demonstrated to be better performing than pneumatic or hydraulic systems in many applications. Problem areas are mostly related to the controllers in the system which therefore require a large degree of redundancy built into the control systems.

THRUST VECTOR CONTROL REQUIREMENTS

- FLIGHT PATH STEERING
- VEHICLE C.G. OFFSET
- THRUST DIFFERENTIAL
- NON-UNIFORM DEPLETION OF PROPELLANTS
- ENGINE-OUT
- TANK JETTISONING
- ENGINE JETTISONING
- PROPELLANT SLOSHING
- VEHICLE ELASTIC MOTION

PHS 1/8/92

Various vehicle factors have to be considered in determining the thrust vector control requirements for a space vehicle.

A basic consideration is the flight path steering requirement. For an orbit launched vehicle, this requirement is minimal and is not critical.

A number of alignment factors, including thrust differential, vehicle c.g. offset, non-uniform depletion of propellant, engine-out, tank jettisoning, and engine jettisoning, require adjustment of the thrust vector.

Propellant sloshing and vehicle elastic motion may be coupled and must be considered in that context.

While a comprehensive survey has not been accomplished for this study, it was recognized that the engine-out event could have a major impact on the requirements. Accordingly, an assessment of this particular factor was made to obtain an indication of the magnitude of the requirement.

SURVIVING PROPULSION MODULE REQUIREMENTS

- Reactor burn time requirements could increase by 7% to 35% for the three engine case and 16% to 70% for the two engine case
- If no engine jettison capability incorporated in design, surviving propulsion modules must be able to function in intense radiation and thermal environment caused by disabled engine
- Gimbal requirements for run tank designs are worst for 1 of 2 engines out at maximum displacement, rate and acceleration of 7.5°, 3.5°/sec and 20°/sec² respectively
- Gimbal mechanism must be robust and capable of vehicle control for extended duration at or near the maximum engine out null position of 5°

KMS 1/17/92

THRUST VECTOR CONTROL REQUIREMENTS

- FLIGHT PATH STEERING
- VEHICLE C.G. OFFSET
- THRUST DIFFERENTIAL
- NON-UNIFORM DEPLETION OF PROPELLANTS
- ENGINE-OUT
- TANK JETTISONING
- ENGINE JETTISONING
- PROPELLANT SLOSHING
- VEHICLE ELASTIC MOTION

PHS 1/8/92

Various vehicle factors have to be considered in determining the thrust vector control requirements for a space vehicle.

A basic consideration is the flight path steering requirement. For an orbit launched vehicle, this requirement is minimal and is not critical (unless a meteor/debris avoidance system is included).

A number of alignment factors, including thrust differential, vehicle c.g. offset, non-uniform depletion of propellant, engine-out, tank jettisoning, and engine jettisoning, require adjustment of the thrust vector.

Propellant sloshing and vehicle elastic motion may be coupled and must be considered in that context.

While a comprehensive survey has not been accomplished for this study, it was recognized that the engine-out event could have a major impact on the requirements. Accordingly, an assessment of this particular factor was made to obtain an indication of the magnitude of the requirement.

THRUST VECTOR CONTROL REQUIREMENTS - 1 of 2 Engines Out

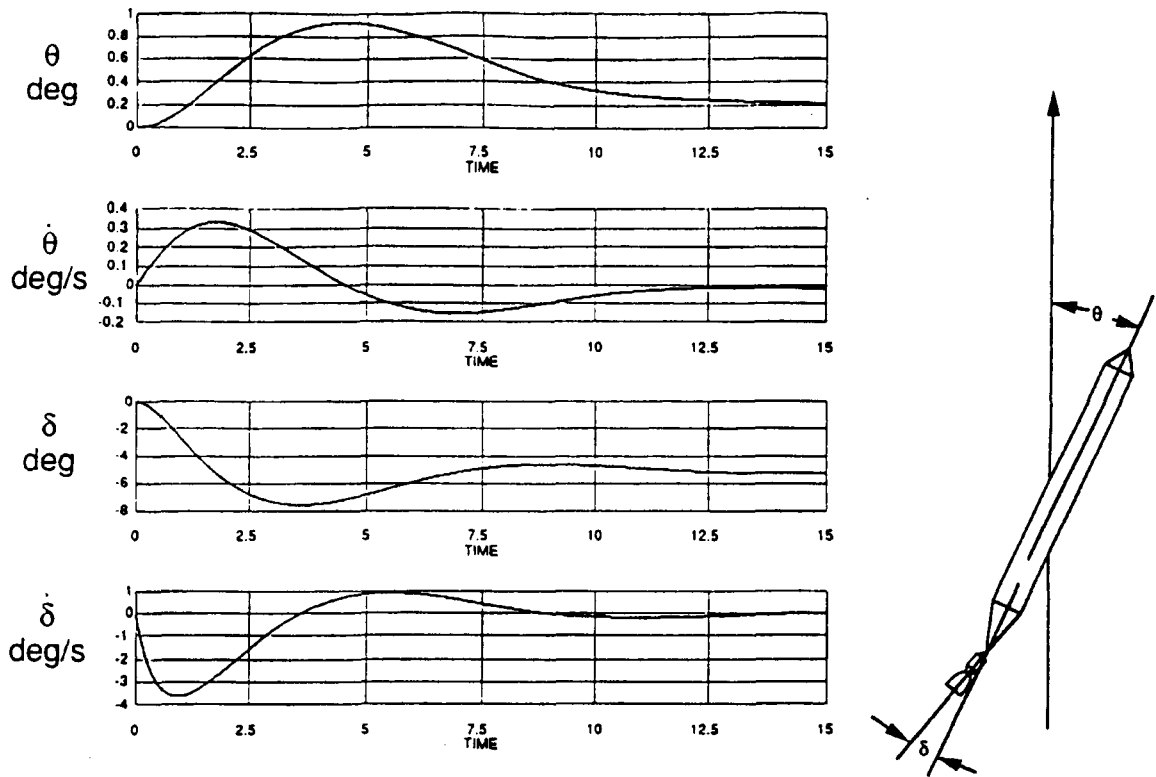

PHS 1/8/92

A dynamic guidance and control simulation was developed to examine the vehicle control response and engine gimbaling requirements for the case where one engine of 2 fails. The vehicle mass distribution was examined and it was concluded that the worst case could be approximated with the Mars transfer injection maneuver tanks jettisoned and the aft core tank full of propellant. Instantaneous shutdown of the faulted engine also was assumed for the worst case.

A control loop was formulated and typical PID (Proportional Integral Differential) control gains were applied to obtain what appeared to be favorable results. As indicated in the plots of the results, the maximum vehicle alignment excursion is less than 1 degree (occurring about 4.5 seconds into the transient) and the excursion rate is about 0.3 degrees/second (at 2 seconds after engine thrust termination). The maximum engine gimbal response is approximately 7.5 degrees (at 3.5 seconds) requiring a maximum gimbal rate of about 3.5 degrees/second (at about 1 second). The engine-out null position is about 5 degrees parallel to the radial position vector of the faulted engine.

The control simulation maximum gimbal acceleration is about 20 degrees/second². This compares with a total deflection rate of 114 degrees/second² for the Centaur engines.

THRUST VECTOR CONTROL REQUIREMENTS - 1 of 3 Engines Out

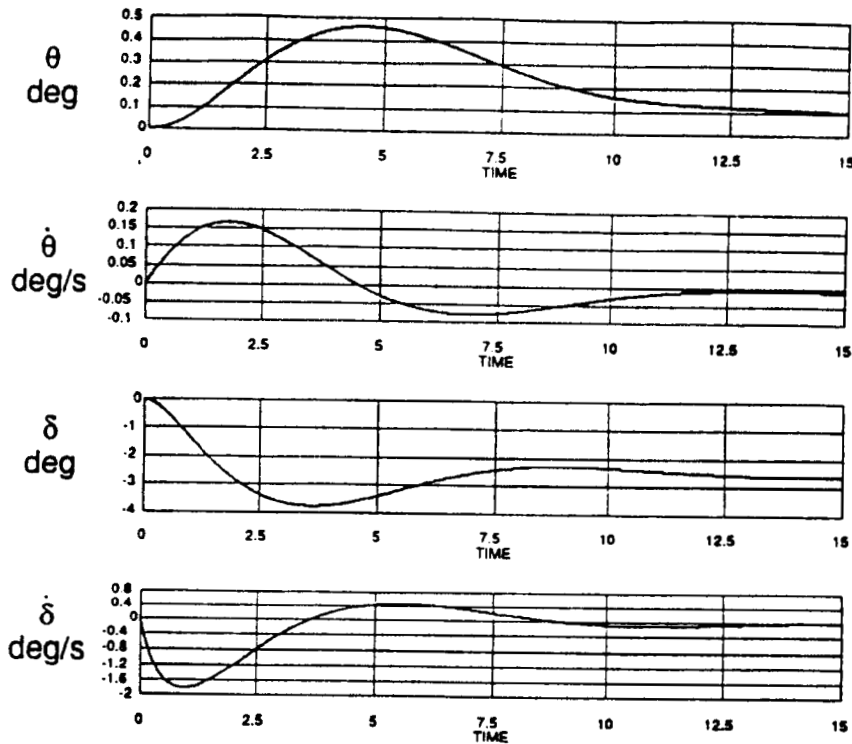

PHS 1/8/92

A dynamic guidance and control simulation was developed to examine the vehicle control response and engine gimbaling requirements for the case where one engine of 3 fails. The vehicle mass distribution was examined and it was concluded that the worst case could be approximated with the Mars transfer injection maneuver tanks jettisoned and the aft core tank full of propellant. Instantaneous shutdown of the faulted engine also was assumed for the worst case.

A control loop was formulated and typical PID (Proportional Integral Differential) control gains were applied to obtain what appeared to be favorable results. As indicated in the plots of the results, the maximum vehicle alignment excursion is less than 0.5 degree (occurring about 4.5 seconds into the transient) and the excursion rate is less than 0.2 degrees/second (at 2 seconds after engine thrust termination). The maximum engine gimbal response is approximately 4 degrees (at 3.5 seconds) requiring a maximum gimbal rate of 2 degrees/second (at about 1 second). The engine-out null position is about 3 degrees parallel to the radial position vector of the faulted engine.

The control simulation maximum gimbal acceleration is about 10 degrees/second². This compares with a total deflection rate of 114 degrees/second² for the Centaur engines.

CONCLUSIONS - THRUST VECTOR CONTROL REQUIREMENTS

- | | | |
|--------------------------------------|---------------|---------------|
| • ENGINE-OUT REQUIREMENTS: | <u>1 OF 2</u> | <u>1 OF 3</u> |
| DISPLACEMENT, degrees | 7.5 | 4 |
| RATE, degrees/second | 3.5 | 2 |
| ACCELERATION, degrees/s ² | 20 | 10 |
| NULL, degrees | 5 | 3 |
- THE ENGINE-OUT REQUIREMENTS FOR THE BOOST PUMP DESIGNS WILL BE GREATER AND SHOULD BE ANALYZED.
 - TANK AND ENGINE JETTISON CONDITIONS COULD BE SIGNIFICANT AND SHOULD BE ANALYZED.
 - ALLOWANCE OF ABOUT 2 DEGREES APPEARS TO BE ADEQUATE FOR OTHER REQUIREMENTS.

PHS 1/8/92

The thrust vector control requirements have been determined for the engine-out event for the vehicle designed with a run tank. The displacement, gimbal rate, gimbal acceleration, and null position are about twice as great for the 3 engine installation with the run tank design as they are for the 2 engine installation of the same basic design. For the designs with the run tank, the requirements do not appear to be excessive. The requirements for the boost pump propulsion system designs could be significantly greater, however, and should be analyzed.

The requirements for tank and engine jettison events could also be significant and should be analyzed. In any case, however, these events would not be concurrent with the engine-out event and therefore should not increase the overall gimbaling requirements.

Some other conditions and events, such as propellant sloshing, could be concurrent with engine-out. Such additional requirements should not be major, however, and probably can be covered with a nominal allowance of, say, 2 degrees.

TECHNOLOGY REQUIREMENTS

- 1) Robotic Coupling Tools/Techniques - On-orbit Assembly Of Core Tanks & Propulsion Modules
- 2) On-orbit Propellant Transfer - Top-off Propellant Tanks For Maximum Capability Missions
- 3) Boost Pumps - Six Times Mass Flow Of Centaur, GH2 Turbine Drive
- 4) Radiation Hardened Thrust Vector Controlers And Engine Controllers - Gamma Heating And Charged Particle Upsets
- 5) Run Tank Vent/Fill Systems - Vent GHe From Run Tank For In-space Restarts
- 6) Mixing Conditions With Bulk Heated Propellant - Predict LH2 Temperature For Turbopump Restart Conditions
- 7) Engine Jettison System - Reduce Engine-out Vehicle Mass, Prevent Good Engine Obstruction By Dysfunctional Engine
- 8) Integrated Health Monitoring & Built-in Test - Reduce In-space Checkout Time/Cost, Automatically Compensate For failed/off-nominal Conditions

JWP 12/19/81

Robotic coupling tools/ techniques refers to the need for an OMV-type tug with mechanical manipulation capabilities. This tool would be used to mate core tanks, auxilliary tanks, propulsion modules and other components after delivery by launch vehicle to an assembly orbit. On-orbit propellant transfer capability would be needed to compensate for boiloff during assembly periods, and undertanking done to keep within launch vehicle delivery constraints. Boost pumps were developed for Centaur. However, those needed for an NTR stage would need to maintain six times their mass flow. Centaur turbopumps were driven by Hydrogen Peroxide. Those for an NTR stage might require special materials since driven by GH2 from the engine cooling jacket. Radiation hardened controllers for the engine and fluid system valves will be required. Normal Centaur electronics would be subject to gamma heating damage and charged particle upset. Run tank vent/fill systems must be developed. At mission start, the run tank is pressurized with GHe. After MECO 1, propellant from core tanks is to fill and flow thru the run tanks to the engines. For minimum ullage, pressurization gases need to be vented from the run tank before it receives with the core propellant. Mixing conditions with bulk heated propellant need to be examined with CFD codes and experimental simulators able to model and predict existence of either stratified or circulation mixed propellant conditions. Unlike circulation mixed fluid, stratified propellant could allow non-uniform temperature of LH2 delivered to turbopump inlets over the duration of tank drain. Additional tank pressurization, which could impact design, would be needed to ensure net positive suction head conditons were met at all times. An engine jettison system to discard a disfunctional propulsion module would reduce the mass of the vehicle, and thus the performance impact of engine-out. It would eliminate the possibility of a dead module staying critical and physically distorting to obstruct gimbaling the remaining module. IHM and Smart Bit allow automated checkout to reduce the cost of in-space operations. It also allows off-nominal and inipient failure conditions to be compensated for at electronic speed.

SUMMARY AND CONCLUSIONS

KMS 1/7/92

CONCLUSIONS

- **A cluster of multiple propulsion modules coupled to a core tank is feasible**
- **Hard coupling multiple nuclear thermal rocket engines to a core tank is an attractive alternative**
 - **Boost pumps utilized for engine start/restart**
 - **Upper and lower core tanks**
 - **Propulsion system integrated and checked out on the ground for single launch on an HLLV**
- **Three engine cluster appears to be more desirable than two engine cluster**
 - **Higher reliability**
 - **Less performance penalty in engine out scenario**
 - **Reduced reactor burn time requirements in engine out scenario**
 - **Lower thrust engines may cost less to develop**
- **May not be desirable to abort with 1 of 3 engines out, after TMI**
 - **Minimal reactor and propellant penalties, great mission success benefits**

KMS 1/7/92

PROPULSION SYSTEM ISSUES

- NUMBER/THRUST OF ENGINES
- ABORT STRATEGY VS. NUMBER OF ENGINES
- SINGLE VS. DUAL TURBOPUMPS - F(NO. OF ENGINES)
- NPSH SUPPLY CONCEPT (RUN TANK VS. BOOST PUMP)
- ENGINE JETTISON PROVISIONS
- RADIATION HARDENING OF ENGINE/TVC CONTROLLERS
- FEASIBILITY OF VARIABLE INTERNAL SHIELD (VS. SPLIT SHIELD)
- ROBOTIC REQUIREMENTS FOR ON-ORBIT COUPLING
- ON-ORBIT PROPELLANT TRANSFER REQUIREMENTS
- ENGINE CHECKOUT REQUIREMENTS
- ENGINE HEALTH MONITORING REQUIREMENTS

PHS 1/9/92

A number of major issues have to be resolved in order to adequately specify the propulsion system for a nuclear space transfer vehicle. The number and thrust of the engines must be determined based on an analysis of the initial and ultimate mission requirements, the cost of ground test facilities, and launch manifest considerations, as well as the reliability and engine-out capability of the engine cluster. The vehicle abort strategy and resolution of the requirement for single vs. dual turbopumps, in turn, are dependent upon the decision on the number of engines in the cluster.

The necessity for reactor cooling of a faulted engine can be avoided and abort mission performance can be improved if the faulted engine can be jettisoned. The experience available from the launch of 500 Atlases with jettisoned booster engines should be applied to determine what jettison features can be used with the clustered nuclear rocket propulsion system.

A major weight savings can be achieved if the engine thrust chamber can be developed with a variable internal shield. This is particularly critical with a clustered engine installation where side shielding is required to protect the adjacent run tank (or far side of the core tank bottom, in the case of the design with a boost pump). Accordingly, the feasibility of designing the thrust chamber with a variable internal shield should be explored.

On-orbit issues include coupling of the propulsion module to the vehicle and propellant transfer. The requirements for these operations should be analyzed in the context of design and development implications.

In order to establish the number and type of control and sensor interface connectors that must be provided, a definition of the engine checkout and health monitoring requirements must be derived. These requirements could have a major impact on the concept and location of the connector panels used for coupling the propulsion module to the vehicle.

SUMMARY AND CONCLUSIONS

- **Engine jettison capability is a must**
 - Jettisoning failed engine will improve reactor and propellant abort margins as well as reduce radiation and thermal protection requirements on the surviving propulsion module(s)
- **Radiation hardening of engine/TVC controllers should result in substantial weight savings**
 - The alternative is local electronics shielding or side shields on reactor
 - Ability to harden/locally shield will drive selection of TVC actuator
- **Side shielding of reactor may offer substantial design/operations benefits**
 - Reduce disk shield mass
 - Simpler installation on ground or in orbit
- **TVC actuator displacement and gimbal rate and power requirements are within current state of the art**
 - Displacement and rate calculated, actuator power by analogy

KMS 1/7/92

SUMMARY AND CONCLUSIONS

- **Propulsion system design is dependant on man-rating requirements**
- **On orbit propellant transfer for tanking/topping propellant tanks**
- **Run tanks should be launched empty**
 - Large surface area/volume ratio and on orbit assembly time
 - Reduce structural mass requirements
- **Integrated health management is a must for any NTR**
 - IHM/Smart Bit architecture implications will have significant impact on propulsion system mass and reliability
- **The Earth to Orbit lift and volume constraints, coupled with on orbit operation significantly affect the propulsion module/system design**

KMS 1/7/92