

519-43
E-6402

NASA Technical Memorandum 103719

In-Flight Near- and Far-Field Acoustic Data
Measured on the Propfan Test Assessment
(PTA) Testbed and With an
Adjacent Aircraft

Richard P. Woodward and Irvin J. Loeffler
Lewis Research Center
Cleveland, Ohio

April 1993

NASA

IN-FLIGHT NEAR- AND FAR-FIELD ACOUSTIC DATA MEASURED ON THE PROPFAN TEST ASSESSMENT (PTA) TESTBED AND WITH AN ADJACENT AIRCRAFT

Richard P. Woodward and Irvin J. Loeffler
National Aeronautics and Space Administration
Lewis Research Center
Cleveland, Ohio 44135

SUMMARY

Flight tests to define the far-field tone source at cruise conditions have been completed on the full-scale SR-7L advanced turboprop that was installed on the left wing of a Gulfstream II aircraft. This program, designated Propfan Test Assessment (PTA), involved aeroacoustic testing of the propeller over a range of test conditions. These measurements defined source levels for input into long-distance propagation models to predict en route noise. In-flight data were taken for seven test cases. Near-field acoustic data were taken on the Gulfstream fuselage and on a microphone boom that was mounted on the Gulfstream wing outboard of the propeller. Far-field acoustic data were taken by an acoustically instrumented Learjet that flew in formation with the Gulfstream. These flight tests were flown from El Paso, Texas, and from the NASA Lewis Research Center. This report presents a comprehensive listing of the aeroacoustic results from these flight tests which may be used for future analysis.

INTRODUCTION

Modern high-speed propeller (advanced turboprop) aircraft are expected to operate on 50 to 60 percent less fuel than the 1980 vintage turbofan fleet while matching the turbofan's flight speed and performance. They also will consume 15 to 30 percent less fuel than advanced turbofan engines (ref. 1). However, the potential noise generated by such aircraft, which includes both in-flight cabin noise and community noise during takeoff and landing, requires investigation (ref. 2).

The NASA Lewis Research Center in Cleveland, Ohio, contracted with Lockheed Aircraft to modify a Gulfstream II aircraft as a flying testbed for an advanced single-rotation propeller and its related propulsive hardware (refs. 3 and 4). This program, designated Propfan Test Assessment (PTA), involved extensive aeroacoustic testing of the installed propeller, which was mounted on the left wing of a Gulfstream II aircraft. (The Gulfstream's two aft-mounted turbojet engines were used for takeoff, landing, and auxiliary cruise power.) The test propeller, designated SR-7L, was manufactured for the project by the Hamilton Standard Division of United Technologies. The propeller had eight blades and a diameter of 2.74 m (9.0 ft). Design and performance results for the propeller and drive system can be found in references 5 to 7.

A prime objective of the PTA test was to map the propeller source noise directivity pattern of the SR-7L propeller under actual flight conditions. This test series was flown from the Lockheed-Georgia facility and included both ground flyover noise measurements and inflight source noise mapping with the acoustically instrumented NASA Learjet (refs. 8 to 11).

A "follow-on" test series with the PTA aircraft was conducted to obtain specialized data that were not acquired in the first test series. These follow-on tests included measuring the ground and Learjet station-keeping noise to obtain a data base for en route noise, as well as

measuring propeller blade pressure, video thermography, and structure-borne noise (ref. 12). These flights were flown out of El Paso, Texas, and ground noise measurements (ref. 13) were made at the White Sands, New Mexico, test range. Additional flights were made from NASA Lewis.

Figure 1 shows the PTA and Learjet aircraft flying in formation. The PTA aircraft/SR-7L propeller was operated at seven test conditions that covered a range of propeller tip speeds and aircraft flight parameters. The source definition portion of the en route noise tests is the subject of this report. Reference 14 presents an analysis of the Learjet-measured source noise from these follow-on flight tests.

Extensive wind tunnel aeroacoustic tests of a 62.2-cm- (24.5-in.-) diameter model of the SR-7L (designated SR-7A) were made at NASA Lewis prior to the full-scale flight tests. These tests explored cruise conditions (Mach 0.7, ref. 15) and takeoff/approach conditions (Mach 0.2, ref. 16). Results of these model propeller tests are not included herein.

This report presents the "as-measured" acoustic data for the PTA aircraft and Learjet microphones which were taken during the follow-on test series. In-depth interpretation of the data is not attempted. Data are presented in tabular form with additional corresponding data for the propeller operating conditions and Learjet station-keeping locations, thus giving a comprehensive compilation of the follow-on acoustic tests results. Selected sideline and azimuthal directivity plots of the acoustic data are also presented (without analysis) in this report.

TEST PROCEDURE

The Gulfstream II aircraft was extensively modified by Lockheed-Georgia to accommodate the wing-mounted SR-7L propeller. As shown in the sketch of figure 2, these modifications included increasing the structural strength of the left wing and adding a counterbalance weight on the right wingtip. The Gulfstream aircraft carried instrumentation to monitor the aeroacoustic performance of the propeller as well as to record the aircraft flight conditions.

The SR-7L propeller was designed for a 0.80 cruise Mach number at a 10 688-m (35 000-ft) altitude (see table I, and ref. 5). This 8-bladed propeller had a design tip speed of 244 m/sec (800 ft/sec). Figure 3 is a photograph of the SR-7L propeller installed on the Gulfstream wing. Figure 4 is a side view of the installed propeller.

Acoustic Instrumentation

Acoustic instrumentation on the Gulfstream included flush-mounted microphones on the aircraft fuselage and on an outboard microphone boom. Figure 5 and table II show the locations of these microphones relative to the SR-7L propeller. The fuselage microphones reported herein were located on a lateral line of closest propeller approach. (Additional microphones were located at other fuselage locations.) The microphone boom was located outboard of the propeller diametrically opposite of the line of fuselage microphones (fig. 5(a)). The plane containing the propeller axis and the axes of the two microphone arrays was tilted approximately 10° from the horizontal. Both the fuselage microphones and boom microphones were located 1.12 propeller diameters from the propeller axis of rotation, or 0.62 diameters from the propeller tip. Thus,

it is likely that propeller noise measurements from these Gulfstream-mounted microphones include some near-field influences. The acoustic signals from the Gulfstream aircraft were recorded on analog tape aboard the aircraft for post-test analysis.

The NASA Lewis Learjet has been used for several propeller flight noise measurement tests (refs. 11, 17, and 18). The Learjet was instrumented with flush-mounted wingtip and nose side microphones for these earlier tests. Additional microphones were added to the Learjet nose top and cabin roof for the PTA station-keeping tests to allow measurement of the propeller noise field below the aircraft in support of ground noise measurements and sound propagation theory validation. Two essentially adjacent microphones were located at each measurement station, for a total of twelve microphones on the Learjet.

Figure 6 shows a wingtip microphone installation on the Learjet. The wingtip microphones were mounted on a plate (fig. 7) that replaced the navigation lights during the acoustic test flights. Figure 8 shows the location of the nose side microphones on the Learjet. Figure 9 shows the locations of the Learjet microphones, referenced from the most forward location on the Learjet nose. The acoustic signals were monitored for data quality and recorded on magnetic tape aboard the aircraft for later analysis. The acoustic spectra of the Learjet engine noise were sufficiently different from those of the propeller to prevent significant data contamination.

Learjet Station-Keeping Positioning

Figure 10 shows the designations for the sideline and azimuthal station-keeping locations used during formation flight. Two methods were used to fix the location of the Learjet relative to the SR-7L propeller (and Gulfstream aircraft), with the Learjet crew pilots viewing the Gulfstream either visually or with a video camera and display. Sideline surveys at 90° and 60° azimuthal locations were flown optically, with the Learjet pilots maintaining visual contact with the Gulfstream. Surveys were initiated from behind the Gulfstream at the 135° or "G" location, and progressed forward as far as visual contact permitted. Aircraft separation for these cases was on the order of 61 m (200 ft). A 35-mm film camera mounted on a protractor device was used to verify the sideline angle. Photographs taken at each data point were later used with an image scaling technique to determine the actual source-to-microphone distances. The measuring station and microphone location geometry (fig. 9) of the Learjet were incorporated to determine the actual distance and measuring angle for each Learjet microphone.

Limited visibility of the Gulfstream from the Learjet resulted in a different positioning technique for the 30° and 0° azimuthal positions below the PTA aircraft. A wide-angle video camera was located such that it scanned upward through a viewing port in the Learjet cabin roof. Desired Gulfstream flight positions were then designated on viewing screens inside the Learjet. The Learjet pilots then flew the Learjet such that the Gulfstream was at the desired data location, as shown on a display template. The video flights were flown at typical sideline separations of about 154 m (500 ft). A third "safety" aircraft was flown with the Gulfstream and Learjet for these "video" flights to ensure safe aircraft separation. (It was flown sufficiently far away from the research aircraft to avoid signal contamination.)

A shaft-order signal from the SR-7L propeller was transmitted from the Gulfstream aircraft to the Learjet for inclusion in the analog data record. The plan was to use this signal for data enhancement to compensate for the increased aircraft separation distances associated with the 30° and 0° azimuthal locations. However, the signal enhancement techniques proved

unsatisfactory because of separation distances, small relative aircraft movements, and other factors. Subsequently, the Learjet pilots determined that some of the 30° and 0° azimuthal location sidelines could be flown visually at the closer aircraft separation distances, with significantly greater data resolution. The video signal for the 30° and 0° azimuthal locations was recorded for later source-to-microphone distance calibrations using image scaling techniques.

Test Matrix

Table III shows the test matrix for the PTA follow-on test series. Seven SR-7L operating conditions were evaluated, as shown in the table. The test cases were numbered 1 to 4 and 6 to 8. (Case 5 at 610 m (2000 ft) altitude was not flown because of safety considerations.) Cases 1, 7, and 8 investigated the effect of propeller tip speed at Mach 0.70 and 10 688-m (35 000 ft) altitude. Case 6 most closely approximates the propeller design conditions of 0.80 Mach flight speed, although with a somewhat higher than design propeller tip speed. Cases 2 and 3 explore the effect of flight speed (Mach 0.70 and 0.50, respectively) at 6096-m (20 000-ft) altitude. This change in flight speed was, of course, accompanied with a significant change in the propeller operating parameters. Case 4 was flown at Mach 0.59 and 4267-m (14 000-ft) altitude.

Figure 11 is a propeller operating map of power coefficient versus advance ratio. Operating conditions for the seven test cases as well as the design point for the SR-7L propeller are shown on this plot.

Values for the blade setting angle were not available during the follow-on test program. The design blade setting angle (see table I) was 57.5°. The SR-7L propeller setting angle was adjusted automatically in flight to compensate for power requirements. The unavailability of the blade setting angle value during these follow-on tests introduced an additional unknown in data comparisons between test cases. (Aerodynamic tests of the model, SR-7A, propeller showed that a setting angle of 60.1° was required to achieve design performance at Mach 0.80 cruise conditions.)

DATA COMPILATIONS

Measured Aeroacoustic Results

Tables IV to IX present a comprehensive listing of the results from the PTA/Learjet follow-on tests. The listings are subdivided into test cases, with headings for the Learjet station-keeping position (in accordance with the methodology of fig. 10) and the NASA-designated acoustic run number. The results within a test case are presented according to microphone position.

Table IV lists the SR-7L aerodynamic performance along with flight conditions of the PTA aircraft. The nacelle tilt was fixed at -1.00° for the entire series of follow-on tests (see fig. 12), although tests were conducted with other nacelle tilt angles earlier in the PTA/SR-7L test program. The upwash angle at the propfan estimated from panel method calculations (ref. 10) was about 1.0°, effectively canceling the nacelle tilt angle such that the measured aircraft angle-of-attack was close to the actual propeller inflow angle. As previously discussed, the propeller

blade angle measurement was defective throughout the test program, so these results are unavailable.

Table V lists the Learjet station-keeping positions for each of the test points. Data are shown for the "prime" Learjet microphone locations (those Learjet measuring locations that were best oriented toward the propeller source), which were the nose side and wingtip for the 90° and 60° azimuthal locations and the nose top and cabin roof for the 30° and 0° azimuthal locations. Angular location and source-to-microphone distances for the secondary measuring locations can be calculated with the geometric information in figure 9.

Table VI lists the "background" or broadband noise levels measured by the various Learjet microphone stations at the test flight speeds and altitudes. Data are shown for frequencies corresponding to the first four propeller tone orders at the design propeller speed, with the fundamental tone at approximately 250 Hz. The PTA aircraft was not present when these measurements were made. Broadband noise levels for the cabin roof (M-11 and 12) are somewhat higher than those for other locations, which may be due to more disturbed airflow in that region. Broadband noise levels for the flush-mounted microphones increase with airspeed, making propeller tone definition in the spectra more difficult at the higher flight speeds.

Table VII lists the as-measured acoustic data taken by the Learjet and also by the Gulfstream fuselage and boom microphones. The middle Gulfstream boom microphone (designated ABM3, located at the 103° sideline angle) was inoperative throughout the follow-on test program. Data are only shown where they could be clearly read in the acoustic spectra. Tone data for the Gulfstream microphones were typically available because of the close proximity of the microphones. However, results for the Learjet microphones are frequently missing because of the greater source-to-microphone separation for the Learjet data. This problem was especially true for data taken at azimuthal angles of 30° and 0° with the video ranging system, where Learjet-PTA separation distances were relatively large.

The data presented herein are for as-measured angular position. Figure 13 shows the relationship between emission and as-measured angles for the four test flight speeds. These differences can be significant. For example, at Mach 0.70, a measured sideline angle of 90° corresponds to an emission angle of only 46°. This results in peak observed propeller tone levels occurring somewhat aft of the propeller plane.

Figure 14 shows a representative sound pressure level spectrum for the SR-7L propeller. This spectrum is for the 90° azimuthal angle, 118° sideline angle with the propeller operating at case 1 conditions.

Adjustments to Acoustic Data for Free-Field Results

The acoustic data presented in table VII are as measured. Adjustments to the data for free-field conditions would include distance corrections for spherical spreading, and adjustments to account for boundary-layer effects at the microphone measuring location. Noise level corrections for distance follow the relationship:

$$\Delta\text{dB} = 20 \log \frac{D_1}{D_2}$$

Data comparisons taken at different flight altitudes would require a similar correction for ambient pressure.

$$\Delta\text{dB} = 10 \log \frac{P_1}{P_2}$$

There is considerable debate as to the best procedure to correct for scattering, boundary-layer refraction, and related flight effects at the microphone measuring station. Reference 19 presents theoretical and experimental data for free-field corrections for a microphone mounted on an infinite cylinder of various diameters. Results are presented for sound waves normal to the microphone surface and for a number of oblique impingement angles. Results in this reference are for no-flow conditions. Although the correction procedures of reference 19 are relatively easy to apply, they do not properly account for airflow conditions, such as those for the present results. References 20 to 22 present possible procedures to better account for airflow effects in correcting the microphone signals to free-field conditions. The importance of these corrections increase at sideline angles away from the propeller plane - especially for upstream (θ less than 90°) measurements. It has been found that the procedure in reference 20 (and by inference, references 21 and 22) does not quantitatively predict the boundary-layer refraction at forward angles (ref. 23). However, it is felt that for a first approximation, the methods of reference 19 give reasonable results near the propeller plane, the region of highest tone level.

Table VIII uses the methodology of reference 19 to show corrections to the Gulfstream boom microphone results at frequencies corresponding to the first four tone orders at design propeller speed. (Test points at off-design propeller test speeds would result in little change in these numbers.)

Table IX uses the methodology of reference 19 to show corrections to the Learjet microphones at the first four tone orders. In this case, the incident sound wave from the propeller varies from normal to 0° to the microphone surface plane. Corrections for each microphone location are shown as a function of station-keeping azimuthal angle (see fig. 10).

Representative Sideline and Azimuthal Directivities

Figures 15 to 28 are included to show sideline and azimuthal directivities for the SR-7L propeller tone using the boundary-layer refraction corrections of reference 19 and adjusting the data to a 154-m (500-ft) sideline distance according to spherical spreading. The results are not adjusted for pressure altitude. The directivity plots are grouped by test case. Sideline directivities for the 90°L azimuthal position are shown for the first three tone orders. Sideline directivities for the 0° azimuthal position are only shown for the first two tone orders because of the unavailability of acoustic tone data at higher frequencies. Gulfstream microphone boom data are also shown on the 90°L sideline directivities. (The dashed line for the boom microphone directivities between ABM2 and ABM3 ($\theta = 90^\circ$ and 114°) signifies the uncertainty in the data due to the missing ABM3 microphone data, which is in a region of expected maximum tone noise.)

There is a consistent difference between results for the Learjet nose and wingtip/cabin roof microphones. This difference has been noted in other Learjet station-keeping data (for example, ref. 18), and the reason for this tone level difference is not clearly known. Speculation has been

made that this difference may relate to different flow/reflection environments at the different measurement stations. A curve has been faired through the data from either the Learjet nose or wingtip, and cabin roof measuring stations for the sideline directivities are presented herein as an aid in interpreting the directivity shape.

Azimuthal directivities for the first two tone orders are also presented for each test case. The maximum sideline tone level measured along each respective sideline is used for the level on these azimuthal directivities. Alternate approaches to generating the azimuthal directivities would be to select a particular sideline angle (typically 105° shows the peak sideline tone level) and use either the maximum measured tone level or value of the faired data curve at that sideline location. However, the azimuthal directivity results using either approach show similar trends with only small differences in actual tone level.

CONCLUDING REMARKS

Acoustic data for the PTA aircraft follow-on test program have been comprehensively presented in a manner that will allow for future analysis of the results. The NASA Learjet was flown along sidelines relative to the SR-7L propeller at several azimuthal locations. The acoustic data are as-measured, for the PTA flush-mounted fuselage and boom microphones, and for the NASA Learjet microphones. Concurrent data are included describing the SR-7L propeller operating conditions, and the Learjet station-keeping locations relative to the propeller. The PTA aircraft/SR-7L propeller was tested at seven operating conditions that explored the effects of propeller tip speed and aircraft flight speed.

REFERENCES

1. Whitlow, J.B., Jr.; and Sievers, G.K.: Fuel Savings Potential of the NASA Advanced Turboprop Program. NASA TM-83736, 1984.
2. Groeneweg, J.F.; and Bober, L.J.: NASA Advanced Propeller Research. NASA TM-101361, 1988.
3. Poland, D.T.; Bartel, H.W.; and Brown, P.C.: PTA Flight Test Overview. AIAA Paper 88-2803, July 1988.
4. Little, B.H., et al.: Propfan Test Assessment (PTA). (LG89ER0064, Lockheed Aeronautical Systems Co.; NASA Contract NAS3-24339), NASA CR-185138, 1989.
5. DeGeorge, C.L.: Large-Scale Advanced Prop-Fan (LAP). NASA CR-182112, 1989.
6. Withers, C.C., et al.: Static Tests of the Propulsion System - Propfan Test Assessment Program. AIAA Paper 87-1728, June 1987.
7. O'Rourke, D.M.: Propfan Test Assessment Propfan Propulsion System Static Test Report. (LG86ER0173, Lockheed-Georgia Co.; NASA Contract NAS3-24339), NASA CR-179613, 1987.

8. Bartel, H.W.; and Swift, G.: Near-Field Acoustic Characteristics of a Single-Rotor Propfan. AIAA Paper 89-1055, Apr. 1989.
9. Reddy, N.N.; Bartel, H.W.; and Salikuddin, M.: Installed Propfan (SR-7L) Far-Field Noise Characteristics. AIAA Paper 89-1056, Apr. 1989.
10. Little, B.H., et al.: Propfan Test Assessment (PTA): Flight Test Report. (LG89ER0026, Lockheed Aeronautical Systems Co.; NASA Contract NAS3-24339), NASA CR-182278, 1989.
11. Woodward, R.P.; and Loeffler, I.J.: Cruise Noise of an Advanced Single--Rotation Propeller Measured from an Adjacent Aircraft. *Internoise '89* Vol. 1, G.C. Maling Jr., ed., Noise Control Foundation, Poughkeepsie, NY, 1989, pp. 243-248.
12. Unruh, J.F.: Structure-Borne Noise Transmission in the Propfan Test Assessment Aircraft (PTA). AIAA Paper 90-3966, Oct. 1990.
13. Wilshire, W.L., Jr.; and Garber, D.P.: En Route Noise Test Preliminary Results. *Internoise '89*, Vol. 1, G.C. Maling Jr., ed., Noise Control Foundation, Poughkeepsie, NY, 1989, pp. 309-312.
14. Woodward, R.P.; and Loeffler, I.J.: Inflight Source Noise of an Advanced Full-Scale Single-Rotation Propeller. AIAA Paper 91-0594, Jan. 1991 (Also, NASA TM-103687).
15. Dittmar, J.H.; and Stang, D.B.: Cruise Noise of the 2/9th Scale Model of the Large-Scale Advanced Propfan (LAP) Propeller, SR-7A. NASA TM-100175, 1987.
16. Woodward, R.P.: Measured Noise of a Scale Model High Speed Propeller at Simulated Takeoff/Approach Conditions. AIAA Paper 87-0526, Jan. 1987 (Also, NASA TM-88920).
17. Balombin, J.R.; and Loeffler, I.J.: Farfield Inflight Measurements of High-Speed Turboprop Noise. AIAA Paper 83-0745, Apr. 1983.
18. Woodward, R.P.; Loeffler, I.J.; and Dittmar, J.H.: Measured Far-Field Flight Noise of a Counterrotation Turboprop at Cruise Conditions. NASA TM-101383, 1989.
19. Wiener, F.M.: Sound Diffraction by Ridgid Spheres and Circular Cylinders. *J. Acoust. Soc. Am.*, vol. 19, no. 3, May 1947, pp. 444-451.
20. Hanson, D.B.; and Magliozzi, B.: Propagation of Propeller Tone Noise Through a Fuselage Boundary Layer. *J. Aircraft*, vol. 22, no. 1, Jan. 1985, pp. 63-70.
21. McAninch, G.L.; and Rawls, J.W., Jr.: Effects of Boundary Layer Refraction and Fuselage Scattering on Fuselage Surface Noise from Advanced Turboprop Propellers. AIAA Paper 84-0249, Jan. 1984.
22. McAninch, G.L.: Effects of Velocity Profile on Boundary Layer Shielding. AIAA Paper 87-2678, Oct. 1987.
23. Dittmar, J.H.; and Krejsa, E.A.: Predicted and Measured Boundary Layer Refraction for Advanced Turboprop Propeller Noise. NASA TM-102365, 1990.

TABLE I.—SR-7L PROPELLER DESIGN PARAMETERS (CRUISE CONDITIONS)

Diameter, m (ft)	2.74 (9.0)
Number of blades	8
Mach number	0.80
Altitude, m (ft)	10 668 (35 000)
Tip speed, m/sec (ft/sec)	244 (800)
Rotational speed, rev/min	1698
Blade setting angle at 3/4 span, deg	^a 57.57
Advance ratio	3.06
Power coefficient	1.45
Power loading, kW/m ² (hp/ft ²)	257 (32.0)
Excitation factor	4.5
Power, kW (hp)	1934 (2592)
Thrust, N (lbf)	6490 (1459)

^aAerodynamic tests of the reduced-diameter SR-7A propeller showed that design conditions were met with a blade setting angle of 60.1°.

TABLE II.—MICROPHONE LOCATIONS

[Fuselage microphones installed at location of closest propeller approach.
(Both boom and fuselage microphones located 1.12 propeller diameters
sideline distance from propeller axis.)]

Gulfstream microphone	Axial location, propeller diameters ^b	Cylindrical diameter of microphone mounting surface		Sideline angle with respect to the propeller upstream axis, deg
		cm	in.	
Fuselage				
M-123	-1.63	239 ↓	94 ↓	34.5
M-193	-1.00			48.2
M-243	-.50			65.9
M-273	-.25			77.4
M-303	0.			90.0
M-323	.25			102.6
M-353	.50			114.1
M-403	1.00			131.8
M-463	1.50			143.3
Boom				
ABM1	-0.50	4.1	1.6	65.9
ABM2	0	8.6	3.4	90.0
ABM3	.25	10.2	4.0	102.6
ABM4	.50	12.7	5.0	114.1
ABM5	1.00	15.9	6.3	131.8

^aNegative upstream, positive downstream from propeller plane.

TABLE III.—TEST MATRIX—PTA/LEARJET STATION-KEEPING DATA

Case	Mach number	Altitude		Propeller tangential tip speed		Aximuthal position, ^a deg	Sideline angles, deg	Number of data positions (including repeats)	Percent full power
		m	ft	m/sec	ft/sec				
1	0.70	10 668	35 000	244	800	90L	60 to 135	6	90
						60L	60 to 120	5	
						30L	60 to 135	11	
						0	60 to 120	17	
2	0.70	6 096	20 000	244	800	90L	60 to 135	7	90
						60L	60 to 120	5	
						30L	60 to 120	9	
						0	60 to 135	8	
3	0.50	6 096	20 000	244	800	90L	60 to 135	7	90
						60L	60 to 120	5	
						30L	60 to 120	9	
						0	60 to 135	8	
4	0.59	4 267	14 000	244	800	90L	60 to 135	7	90
						60L	60 to 120	5	
						30L	60 to 120	9	
						0	60 to 135	8	
b6	0.77	10 668	35 000	256	840	90L	60 to 135	6	100
						0	0 to 120	3	
						90L	60 to 135	6	
						30L	75 to 120	4	
7	0.70	10 668	35 000	213	700	90L	60 to 135	6	90
						30L	75 to 120	4	
						0	60 to 135	8	
						90L	60 to 135	6	
8	0.70	10 668	35 000	189	620	90L	60 to 135	6	90
						30L	75 to 120	4	
						0	60 to 135	8	
						90L	60 to 135	6	

^aMeasured left (L) or right (R) of vertical center.

^bCase 5 at 610 m (2000 ft) was not flown because of safety considerations.

TABLE IV.—GULFSTREAM AERODYNAMIC PERFORMANCE^a

(a) Case I.

Performance	Position ^b											
	1B			1C			1D			1E		
	89-21	89-23	89-21	89-23	89-21	89-23	89-21	89-23	89-21	89-23	89-21	89-23
	Flight											
	Run											
	106	142	105	109	141	104	108	140	103	107	139	
Flight Mach number	0.699	0.704	0.704	0.705	0.703	0.695	0.705	0.704	0.702	0.702	0.703	
Altitude, m, (ft)	10 690 (35 072)	10 693 (35 082)	10 694 (35 084)	10 704 (35 118)	10 692 (35 078)	10 681 (35 052)	10 715 (35 154)	10 690 (35 071)	10 681 (35 044)	10 708 (35 130)	10 686 (35 058)	
Propeller power, kW (shaft hp)	1777 (2382)	1787 (2395)	1781 (2388)	1802 (2416)	1814 (2431)	1767 (2369)	1797 (2409)	1775 (2379)	1781 (2387)	1785 (2393)	1790 (2400)	
Propeller torque, N·m (ft·lbf)	9908 (7308)	9913 (7312)	9948 (7338)	10 056 (7417)	10 018 (7389)	9873 (7282)	10 010 (7383)	9841 (7259)	9938 (7330)	9961 (7347)	9917 (7315)	
Tangential tip Mach number	0.815	0.817	0.816	0.818	0.820	0.815	0.818	0.816	0.816	0.816	0.818	
Helical tip Mach number	1.074	1.079	1.078	1.081	1.081	1.072	1.080	1.078	1.077	1.077	1.079	
Propeller thrust, N (lbf)	6241 (1403)	6187 (1391)	6201 (1394)	6289 (1414)	6294 (1415)	6263 (1408)	6258 (1407)	6134 (1379)	6223 (1399)	6245 (1404)	6205 (1395)	
Propeller disk power loading, kW/m ² (hp/ft ²)	236 (29.42)	238 (29.58)	237 (29.49)	240 (29.83)	241 (30.01)	235 (29.26)	239 (29.74)	236 (29.37)	237 (29.48)	237 (29.55)	238 (29.64)	
Nacelle tilt, deg	-1.00	-1.00	-1.00	-1.00	-1.00	-1.00	-1.00	-1.00	-1.00	-1.00	-1.00	
Attack angle, deg	2.81	2.08	2.67	2.64	2.10	2.97	2.64	2.15	2.87	2.68	2.18	
Sideslip angle, deg	0.85	0.18	0.75	0.37	0.18	0.53	0.24	0.30	0.56	0.47	0.22	
Power coefficient	1.35	1.34	1.35	1.36	1.35	1.34	1.36	1.33	1.35	1.35	1.34	
Thrust coefficient	0.37	0.37	0.37	0.37	0.37	0.37	0.37	0.36	0.37	0.37	0.37	
Advance ratio	2.69	2.71	2.72	2.71	2.70	2.68	2.71	2.71	2.71	2.70	2.70	

^aSee table III for test matrix for the different cases.

^bSee table V and figure 10 for station-keeping position information.

TABLE IV.—Continued.

(a) Continued.

Performance	Position ^b												
	1F			1G			2B			2C		2D	
	Flight			Flight			Flight			Flight		Flight	
	89-21	89-23	89-21	89-23	89-21	89-23	89-21	89-23	89-21	89-23	89-21	89-23	89-33
	Run												
	102	138	289	101	288	119	118	297	117	296			
Flight Mach number	0.702	0.704	0.704	0.705	0.703	0.705	0.705	0.717	0.703	0.701			
Altitude, m, (ft)	10 685 (35 056)	10 684 (35 053)	10 811 (35 470)	10 681 (35 042)	10 814 (35 480)	10 734 (35 215)	10 734 (35 215)	10 825 (35 514)	10 735 (35 221)	10 818 (35 492)			
Propeller power, kW (shaft hp)	1768 (2370)	1777 (2382)	1788 (2397)	1780 (2386)	1813 (2430)	1777 (2382)	1784 (2391)	1821 (2441)	1766 (2367)	1808 (2423)			
Propeller torque, N·m (ft·lbf)	9863 (7275)	9860 (7273)	9822 (7245)	9958 (7345)	9955 (7343)	9921 (7318)	9946 (7336)	9995 (7372)	9854 (7268)	9921 (7318)			
Tangential tip Mach number	0.816	0.817	0.817	0.814	0.817	0.815	0.817	0.818	0.814	0.818			
Helical tip Mach number	1.076	1.079	1.079	1.077	1.078	1.078	1.078	1.088	1.076	1.077			
Propeller thrust, N (lbf)	6169 (1387)	6147 (1382)	6120 (1376)	6192 (1392)	6236 (1402)	6174 (1388)	6223 (1399)	6094 (1370)	6147 (1382)	6241 (1403)			
Propeller disk power loading, kW/m ² (hp/ft ²)	235 (29.27)	236 (29.42)	238 (29.59)	237 (29.47)	241 (30.00)	236 (29.42)	237 (29.52)	242 (30.14)	235 (29.22)	240 (29.92)			
Nacelle tilt, deg	-1.00	-1.00	-1.00	-1.00	-1.00	-1.00	-1.00	-1.00	-1.00	-1.00			
Attack angle, deg	2.91	2.18	3.53	2.94	3.52	2.28	2.33	2.84	2.35	3.18			
Sideslip angle, deg	0.64	0.37	0.09	0.61	0.64	0.23	0.11	0.16	0.13	0.30			
Power coefficient	1.34	1.33	1.35	1.36	1.37	1.36	1.36	1.38	1.35	1.36			
Thrust coefficient	0.37	0.36	0.37	0.37	0.38	0.37	0.37	0.37	0.37	0.37			
Advance ratio	2.71	2.71	2.71	2.71	2.70	2.72	2.71	2.76	2.71	2.69			

^bSee table V and figure 10 for station-keeping position information.

TABLE IV.—Continued.

(a) Continued.

Performance	Position ^b									
	2E		2F		5B		5C		5D	
	89-21	89-33	89-21	89-33	89-21	89-33	89-21	89-33	89-21	89-33
	Flight									
	Run									
	116	295	115	294	114	113	293	112	292	
Flight Mach number	0.705	0.706	0.700	0.707	0.706	0.700	0.707	0.699	0.704	
Altitude, m (ft)	10 735 (35 219)	10 811 (35 470)	10 731 (35 207)	10 810 (35 465)	10 728 (35 196)	10 720 (35 172)	10 816 (35 486)	10 721 (35 174)	10 798 (35 426)	
Propeller power, kW (shaft hp)	1815 (2423)	1810 (2426)	1780 (2386)	1804 (2418)	1787 (2395)	1787 (2395)	1814 (2432)	1778 (2384)	1815 (2433)	
Propeller torque, N·m (ft·lbf)	10 050 (7413)	9935 (7328)	9924 (7320)	9902 (7304)	9961 (7347)	9961 (7347)	9957 (7344)	9921 (7318)	9963 (7349)	
Tangential tip Mach number	0.819	0.818	0.817	0.817	0.816	0.817	0.819	0.816	0.818	
Helical tip Mach number	1.081	1.080	1.076	1.081	1.079	1.076	1.082	1.075	1.080	
Propeller thrust, N (lbf)	6249 (1405)	6187 (1391)	6249 (1405)	6147 (1382)	6201 (1394)	6281 (1412)	6196 (1393)	6254 (1406)	6236 (1402)	
Propeller disk power loading, kW/m ² (hp/ft ²)	240 (29.92)	241 (29.96)	237 (29.46)	240 (29.86)	237 (29.57)	237 (29.57)	241 (30.03)	212 (26.44)	241 (30.04)	
Nacelle tilt, deg	-1.00	-1.00	-1.00	-1.00	-1.00	-1.00	-1.00	-1.00	-1.00	
Attack angle, deg	2.36	3.11	2.54	2.13	2.45	2.63	3.21	2.63	3.26	
Sideslip angle, deg	0.19	0.24	0.34	0.27	0.07	0.07	0.07	0.04	0.10	
Power coefficient	1.36	1.37	1.35	1.36	1.36	1.35	1.37	1.35	1.37	
Thrust coefficient	0.37	0.37	0.37	0.37	0.37	0.37	0.37	0.37	0.37	
Advance ratio	2.71	2.71	2.69	2.72	2.72	2.69	2.71	2.69	2.70	

^bSee table V and figure 10 for station-keeping position information.

TABLE IV.—Continued.

(a) Continued.

Performance	Position ^b											
	5E						5F					
	89-21		89-23		89-33		89-21		89-33		89-26	
	Flight											
Run												
	111	143	291	110	290	209	208	207	206	205		
Flight Mach number	0.703	0.704	0.705	0.706	0.709	0.707	0.700	0.074	0.703	0.708		
Altitude, m (ft)	10 712 (35 145)	10 699 (35 101)	10 808 (35 458)	10 729 (35 200)	10 814 (35 479)	10 659 (34 972)	10 660 (34 974)	10 664 (34 987)	10 658 (34 968)	10 664 (34 988)		
Propeller power, kW (shaft hp)	1792 (2402)	1815 (2433)	1824 (2445)	1796 (2407)	1819 (2438)	1825 (2447)	1816 (2434)	1810 (2426)	1809 (2425)	1850 (2480)		
Propeller torque, N-m (ft.-lbf)	9991 (7369)	10 028 (7397)	10 012 (7385)	9996 (7373)	9988 (7367)	10 087 (7440)	10 035 (7402)	10 018 (7389)	10 011 (7384)	10 201 (7524)		
Tangential tip Mach number	0.817	0.821	0.818	0.818	0.817	0.820	0.820	0.819	0.819	0.822		
Helical tip Mach number	1.079	1.082	1.081	1.081	1.082	1.082	1.078	1.080	1.079	1.085		
Propeller thrust, N (lbf)	6258 (1407)	6303 (1417)	6254 (1406)	6236 (1402)	6183 (1390)	6298 (1416)	6347 (1427)	6272 (1410)	6289 (1414)	6378 (1434)		
Propeller disk power loading, kW/m ² (hp/ft. ²)	238 (29.66)	241 (30.05)	242 (30.19)	239 (29.72)	242 (30.10)	243 (30.22)	244 (30.36)	241 (29.96)	240 (29.94)	246 (30.62)		
Nacelle tilt, deg	-1.00	-1.00	-1.00	-1.00	-1.00	-1.00	-1.00	-1.00	-1.00	-1.00		
Attack angle, deg	2.53	2.08	3.28	2.54	3.24	2.32	2.43	2.35	2.29	2.19		
Sideslip angle, deg	0.17	0.27	0.01	0.45	0.15	0.93	0.88	0.91	0.78	0.67		
Power coefficient	1.36	1.35	1.38	1.36	1.38	1.35	1.34	1.34	1.34	1.36		
Thrust coefficient	0.37	0.37	0.38	0.37	0.37	0.37	0.37	0.37	0.37	0.37		
Advance ratio	2.71	2.70	2.71	2.71	2.73	2.71	2.68	2.70	2.70	2.71		

^bSee table V and figure 10 for station-keeping position information.

TABLE IV.—Continued.

(a) Concluded.

Performance	Position ^b						
	7B	7C	7D	7E	7F	7G	
	Flight						
89-26							
Run							
	204	203	202	201	200	199	
Flight Mach number	0.712	0.701	0.698	0.699	0.699	0.704	
Altitude, m (ft)	10 662 (34 981)	10 657 (34 964)	10 658 (34 966)	10 656 (34 960)	10 657 (34 963)	10 655 (34 958)	
Propeller power, kW (shaft hp)	1825 (2447)	1818 (2437)	1814 (2432)	1813 (2430)	1802 (2415)	1806 (2421)	
Propeller torque, N·m (ft·lbf)	10 094 (7445)	10 052 (7414)	10 038 (7404)	10 024 (7394)	9973 (7356)	9997 (7374)	
Tangential tip Mach number	0.819	0.819	0.818	0.819	0.818	0.818	
Helical tip Mach number	1.085	1.078	1.076	1.077	1.077	1.080	
Propeller thrust, N (lbf)	6236 (1402)	6347 (1427)	6370 (1432)	6347 (1427)	6294 (1415)	6254 (1406)	
Propeller disk power loading, kW/m ² (hp/ft ²)	243 (30.21)	242 (30.09)	241 (30.03)	241 (30.00)	239 (29.82)	240 (29.90)	
Nacelle tilt, deg	-1.00	-1.00	-1.00	-1.00	-1.00	-1.00	
Attack angle, deg	2.18	2.37	2.48	2.52	2.54	2.46	
Sideslip angle, deg	0.54	0.42	0.33	0.37	0.46	0.47	
Power coefficient	1.35	1.35	1.35	1.34	1.34	1.34	
Thrust coefficient	0.36	0.37	0.37	0.37	0.37	0.37	
Advance ratio	2.73	2.69	2.68	2.68	2.69	2.70	

^bSee table V and figure 10 for station-keeping position information.

TABLE IV.—Continued.
(b) Case 2.

Performance	Position ^b																																										
	1B			1C			1D			1E			1F			1G			2B			2C																					
	89-24												89-34			89-24			89-34			89-25			89-34																		
												Flight												Run																			
												148			147			146			145			328			144			327			169			168			326				
Flight Mach number	0.694	0.694	0.691	0.703	0.698	0.694	0.712	0.712	0.700	0.712	0.712	0.705	0.712	0.712	0.705	0.712	0.706	0.694	0.691	0.703	0.698	0.694	0.712	0.712	0.700	0.712	0.712	0.705	0.712	0.706	0.694	0.691	0.703	0.698	0.694	0.712	0.712	0.700	0.712	0.712	0.705	0.712	0.706
Altitude, m (ft)	6094 (19 992)	6089 (19 976)	6089 (19 976)	6087 (19 971)	6085 (19 963)	6088 (19 975)	6203 (20 350)	6203 (20 350)	6102 (20 020)	6203 (20 350)	6203 (20 350)	6089 (19 976)	6089 (19 976)	6258 (20 563)	6089 (19 976)	6258 (20 563)	6270 (20 570)	6085 (19 963)	6089 (19 976)	6087 (19 971)	6085 (19 963)	6088 (19 975)	6203 (20 350)	6203 (20 350)	6102 (20 020)	6258 (20 563)	6089 (19 976)	6258 (20 563)	6270 (20 570)	6085 (19 963)	6089 (19 976)	6087 (19 971)	6085 (19 963)	6088 (19 975)	6203 (20 350)	6203 (20 350)	6102 (20 020)	6258 (20 563)	6089 (19 976)	6258 (20 563)	6270 (20 570)		
Propeller power, kW (shaft hp)	3140 (4209)	3118 (4179)	3163 (4240)	3163 (4240)	3162 (4238)	3089 (4141)	3270 (4384)	3270 (4384)	2977 (3991)	3270 (4384)	3270 (4384)	3218 (4314)	3218 (4314)	3279 (4396)	3218 (4314)	3279 (4396)	3297 (4419)	3162 (4238)	3118 (4179)	3163 (4240)	3162 (4238)	3089 (4141)	3270 (4384)	3270 (4384)	2977 (3991)	3279 (4396)	3218 (4314)	3279 (4396)	3297 (4419)	3162 (4238)	3118 (4179)	3163 (4240)	3162 (4238)	3089 (4141)	3270 (4384)	3270 (4384)	2977 (3991)	3279 (4396)	3218 (4314)	3279 (4396)	3297 (4419)		
Propeller torque, N-m (ft-lbf)	17 331 (12 783)	17 225 (12 705)	17 450 (12 871)	17 450 (12 871)	17 457 (12 876)	17 050 (12 576)	19 863 (13 176)	19 863 (13 176)	16 425 (12 115)	19 863 (13 176)	19 863 (13 176)	17 716 (13 067)	17 716 (13 067)	13 918 (13 216)	17 716 (13 067)	13 918 (13 216)	17 994 (13 272)	17 457 (12 876)	17 225 (12 705)	17 450 (12 871)	17 457 (12 876)	17 050 (12 576)	19 863 (13 176)	19 863 (13 176)	16 425 (12 115)	19 863 (13 176)	17 716 (13 067)	13 918 (13 216)	17 994 (13 272)	17 457 (12 876)	17 225 (12 705)	17 450 (12 871)	17 457 (12 876)	17 050 (12 576)	19 863 (13 176)	19 863 (13 176)	16 425 (12 115)	19 863 (13 176)	17 716 (13 067)	13 918 (13 216)	17 994 (13 272)		
Tangential tip Mach number	0.760	0.759	0.761	0.761	0.761	0.761	0.768	0.768	0.761	0.768	0.761	0.756	0.768	0.761	0.768	0.768	0.761	0.759	0.761	0.761	0.761	0.768	0.761	0.756	0.768	0.761	0.768	0.768	0.761	0.759	0.761	0.761	0.761	0.768	0.761	0.756	0.768	0.761	0.756	0.768			
Helical tip Mach number	1.029	1.027	1.036	1.036	1.033	1.031	1.047	1.047	1.034	1.047	1.034	1.034	1.048	1.034	1.048	1.043	1.033	1.027	1.036	1.033	1.031	1.047	1.034	1.034	1.048	1.034	1.048	1.043	1.033	1.027	1.036	1.033	1.031	1.047	1.034	1.034	1.048	1.034	1.034	1.043			
Propeller thrust, N (lbf)	9923 (2231)	9901 (2226)	9812 (2206)	9812 (2206)	9915 (2229)	9750 (2192)	10 039 (2257)	10 039 (2257)	9181 (2064)	10 039 (2257)	9181 (2064)	9861 (2217)	10 084 (2267)	9181 (2064)	10 084 (2267)	10 262 (2307)	9915 (2229)	9901 (2226)	9812 (2206)	9915 (2229)	9750 (2192)	10 039 (2257)	9181 (2064)	9861 (2217)	10 084 (2267)	9181 (2064)	10 084 (2267)	10 262 (2307)	9915 (2229)	9901 (2226)	9812 (2206)	9915 (2229)	9750 (2192)	10 039 (2257)	9181 (2064)	9861 (2217)	10 084 (2267)	9181 (2064)	9861 (2217)	10 262 (2307)			
Propeller disk power loading, kW/m ² (hp/ft ²)	417 (51.97)	414 (51.60)	420 (52.35)	420 (52.35)	420 (52.33)	411 (51.13)	435 (54.13)	435 (54.13)	396 (49.28)	435 (54.13)	396 (49.28)	428 (53.26)	436 (54.27)	396 (49.28)	436 (54.27)	438 (54.56)	420 (52.33)	414 (51.60)	420 (52.35)	420 (52.33)	411 (51.13)	435 (54.13)	396 (49.28)	428 (53.26)	436 (54.27)	396 (49.28)	436 (54.27)	438 (54.56)	420 (52.33)	414 (51.60)	420 (52.35)	420 (52.33)	411 (51.13)	435 (54.13)	396 (49.28)	428 (53.26)	436 (54.27)	396 (49.28)	436 (54.27)	438 (54.56)			
Nacelle tilt, deg	-1.00	-1.00	-1.00	-1.00	-1.00	-1.00	-1.00	-1.00	-1.00	-1.00	-1.00	-1.00	-1.00	-1.00	-1.00	-1.00	-1.00	-1.00	-1.00	-1.00	-1.00	-1.00	-1.00	-1.00	-1.00	-1.00	-1.00	-1.00	-1.00	-1.00	-1.00	-1.00	-1.00	-1.00	-1.00	-1.00	-1.00	-1.00	-1.00	-1.00			
Attack angle, deg	0.93	0.93	0.89	0.89	0.90	0.91	0.83	0.83	0.88	0.83	0.88	0.77	0.82	0.88	0.77	0.88	0.90	0.93	0.89	0.90	0.91	0.83	0.88	0.77	0.82	0.88	0.77	0.88	0.90	0.93	0.89	0.90	0.91	0.83	0.88	0.77	0.82	0.88	0.77	0.88			
Sideslip angle, deg	0.55	0.40	-0.05	-0.05	-0.07	-0.04	0.33	0.33	0.01	0.33	0.01	0.01	0.29	0.01	0.01	0.35	-0.07	0.40	-0.05	-0.07	-0.04	0.33	0.01	0.01	0.29	0.01	0.01	0.35	-0.07	0.40	-0.05	-0.07	-0.04	0.33	0.01	0.01	0.29	0.01	0.01	0.35			
Power coefficient	1.38	1.38	1.39	1.39	1.39	1.36	1.42	1.42	1.31	1.42	1.31	1.43	1.43	1.31	1.43	1.44	1.39	1.38	1.39	1.39	1.36	1.42	1.31	1.43	1.43	1.31	1.43	1.44	1.39	1.38	1.39	1.39	1.36	1.42	1.31	1.43	1.43	1.31	1.43	1.44			
Thrust coefficient	0.35	0.35	0.34	0.34	0.34	0.34	0.35	0.35	0.32	0.35	0.32	0.35	0.35	0.32	0.35	0.36	0.34	0.35	0.34	0.34	0.34	0.35	0.32	0.35	0.35	0.32	0.35	0.36	0.34	0.35	0.34	0.34	0.34	0.35	0.32	0.35	0.35	0.32	0.35	0.36			
Advance ratio	2.87	2.86	2.90	2.90	2.89	2.87	2.91	2.91	2.89	2.91	2.89	2.93	2.91	2.89	2.91	2.89	2.89	2.86	2.90	2.89	2.87	2.91	2.89	2.93	2.91	2.89	2.91	2.89	2.89	2.86	2.90	2.89	2.87	2.91	2.89	2.93	2.91	2.89	2.93	2.89			

^bSee table V and figure 10 for station-keeping position information.

TABLE IV.—Continued.
(b) Continued.

Performance	Position ^b											
	2D			2E			2F			3C		
	89-25	89-34	89-24	89-25	89-24	89-34	89-25	89-24	89-34	89-25	89-24	89-34
	Flight											
	Run											
	167	325	158	166	170	324	157	165	323	278	277	89-28
Flight Mach number	0.705	0.707	0.700	0.706	0.705	0.711	0.699	0.713	0.709	0.695	0.699	
Altitude, m (ft)	6095 (19 997)	6263 (20 547)	6095 (19 997)	6092 (19 978)	6094 (19 995)	6261 (20 541)	3098 (20 006)	6092 (19 986)	6267 (20 560)	6087 (19 972)	6081 (19 952)	
Propeller power, kW (shaft hp)	3210 (4303)	3235 (4336)	3191 (4278)	3189 (4275)	2936 (3936)	3241 (4345)	3162 (4238)	3205 (4296)	3277 (4393)	3195 (4283)	3217 (4312)	
Propeller torque, N-m (ft-lbf)	17 676 (13 035)	17 665 (13 030)	17 592 (12 976)	17 561 (12 953)	16 173 (11 929)	17 705 (13 059)	17 462 (12 880)	17 652 (13 020)	17 892 (13 197)	17 690 (13 048)	17 820 (13 144)	
Tangential tip Mach number	0.756	0.767	0.762	0.757	0.756	0.767	0.760	0.757	0.769	0.755	0.755	
Helical tip Mach number	1.034	1.044	1.035	1.035	1.034	1.047	1.032	1.040	1.046	1.027	1.029	
Propeller thrust, N (lbf)	9826 (2209)	9999 (2248)	10 012 (2251)	9750 (2192)	8838 (1987)	9941 (2235)	9897 (2225)	9661 (2172)	10 141 (2280)	10 044 (2258)	10 039 (2257)	
Propeller disk power loading, kW/m ² (hp/ft ²)	427 (53.12)	430 (53.53)	424 (52.82)	424 (52.79)	390 (48.60)	431 (53.65)	420 (52.32)	426 (53.05)	436 (54.24)	425 (52.89)	428 (53.24)	
Nacelle tilt, deg	-1.00	-1.00	-1.00	-1.00	-1.00	-1.00	-1.00	-1.00	-1.00	-1.00	-1.00	
Attack angle, deg	0.81	0.87	0.76	0.81	0.77	0.84	0.78	0.79	0.82	0.80	0.83	
Sideslip angle, deg	0.02	0.53	0.04	-0.04	-0.17	0.54	-0.10	-0.03	0.39	-0.09	-0.16	
Power coefficient	1.43	1.41	1.39	1.41	1.30	1.42	1.39	1.42	1.43	1.43	1.44	
Thrust coefficient	1.35	0.35	0.35	0.34	0.31	0.35	0.35	3.34	0.35	0.35	0.35	
Advance ratio	2.93	2.90	2.88	2.93	2.93	2.91	2.89	2.96	2.90	2.89	2.91	

^bSee table V and figure 10 for station-keeping position information.

TABLE IV.—Continued.
(b) Continued.

Performance	Position ^b																								
	3D			3E			3F			4C			4E												
	4D			4B			4A			4D			4E												
													Flight												
													89-27			89-28			89-28						
													Run												
													276	275	274	274	273	273	257	271	282	256	270	280	281
Flight Mach number	0.698	0.697	0.700	0.695	0.697	0.705	0.695	0.705	0.695	0.700	0.706	0.700	0.695	0.699	0.697										
Altitude, m (ft)	6081 (19 951)	6078 (19 942)	6077 (19 937)	6071 (19 919)	6084 (19 961)	6098 (20 008)	6087 (19 969)	6079 (19 943)	6106 (20 033)	6079 (19 943)	6106 (20 033)	6079 (19 943)	6086 (19 996)	6079 (19 944)	6076 (19 936)										
Propeller power, kW (shaft hp)	3252 (4359)	3230 (4330)	3231 (4331)	3210 (4303)	3211 (4304)	3239 (4342)	3205 (4296)	3197 (4285)	3230 (4330)	3204 (4295)	3230 (4330)	3197 (4285)	3204 (4295)	3182 (4248)	3169 (4248)										
Propeller torque, N-m (ft-lbf)	18 004 (13 280)	17 892 (13 197)	17 899 (13 202)	17 777 (13 112)	17 774 (13 110)	17 938 (13 231)	17 705 (13 089)	17 707 (13 061)	17 893 (13 198)	17 740 (13 085)	17 893 (13 198)	17 707 (13 061)	17 740 (13 085)	17 618 (12 995)	17 585 (12 971)										
Tangential tip Mach number	0.756	0.755	0.754	0.754	0.754	0.756	0.754	0.754	0.754	0.754	0.756	0.754	0.754	0.755	0.753										
Helical tip Mach number	1.029	1.027	1.029	1.025	1.027	1.034	1.026	1.030	1.034	1.026	1.034	1.030	1.026	1.029	1.026										
Propeller thrust, N (lbf)	10 199 (2293)	10 128 (2277)	10 052 (2260)	10 079 (2266)	10 026 (2254)	9999 (2248)	10 057 (2261)	9919 (2230)	9964 (2240)	10 052 (2260)	9964 (2240)	9919 (2230)	10 052 (2260)	9883 (2222)	9883 (2222)										
Propeller disk power loading, kW/m ² (hp/ft ²)	432 (53.82)	429 (53.46)	429 (53.48)	427 (53.13)	427 (53.14)	430 (53.61)	426 (53.04)	425 (52.91)	429 (53.47)	426 (53.03)	429 (53.47)	425 (52.91)	426 (53.03)	423 (52.66)	421 (52.45)										
Nacelle tilt, deg	-1.00	-1.00	-1.00	-1.00	-1.00	-1.00	-1.00	-1.00	-1.00	-1.00	-1.00	-1.00	-1.00	-1.00	-1.00										
Attack angle, deg	0.82	0.81	0.81	0.85	0.82	0.71	0.86	0.71	0.74	0.84	0.74	0.71	0.84	0.86	0.76										
Sideslip angle, deg	0.11	0.40	0.53	0.17	0.18	-0.09	-0.23	0.00	-0.07	0.27	-0.07	0.00	0.27	0.65	0.04										
Power coefficient	1.45	1.44	1.45	1.44	1.44	1.45	1.44	1.43	1.45	1.44	1.45	1.43	1.44	1.42	1.42										
Thrust coefficient	0.36	0.36	0.35	0.36	0.35	0.35	0.36	0.35	0.35	0.36	0.35	0.35	0.36	0.35	0.35										
Advance ratio	2.90	2.90	2.92	2.90	2.91	2.93	2.90	2.92	2.94	2.90	2.94	2.92	2.90	2.91	2.91										

^bSee table V and figure 10 for station-keeping position information.

TABLE IV.—Continued.

(b) Continued.

Performance	Position ^b													
	4F		4G		5B		5C		5D		5E		5F	
	89-27		89-28		89-24		89-24		89-34		89-24		89-34	
Flight													Run	
Run													Run	
Flight Mach number	0.708	254	279	156	155	154	331	153	330	152	329	0.699	0.707	
Altitude, m (ft)	6101 (20 017)	6096 (20 001)	6076 (19 935)	6069 (20 000)	6097 (20 003)	6093 (19 990)	6201 (20 346)	6091 (19 982)	6206 (20 362)	6098 (19 997)	6203 (20 351)	6098 (19 997)	6203 (20 351)	
Propeller power, kW (shaft hp)	3241 (4345)	3219 (4315)	3164 (4241)	3181 (4264)	3170 (4249)	3159 (4235)	3279 (4396)	3185 (4269)	3269 (4382)	3179 (4261)	3256 (4365)	3179 (4261)	3256 (4365)	
Propeller torque, N-m (ft-lbf)	17 950 (13 240)	17 843 (13 161)	17 568 (12 958)	17 534 (12 933)	17 472 (12 887)	17 417 (12 847)	17 909 (13 210)	17 562 (12 954)	17 843 (13 161)	17 537 (12 935)	17 779 (13 114)	17 537 (12 935)	17 779 (13 114)	
Tangential tip Mach number	0.755	0.754	0.753	0.762	0.762	0.761	0.769	0.762	0.768	0.761	0.768	0.761	0.768	
Helical tip Mach number	1.036	1.034	1.026	1.036	1.032	1.031	1.047	1.032	1.045	1.034	1.045	1.034	1.045	
Propeller thrust, N (lbf)	9941 (2235)	9883 (2222)	9866 (2218)	9910 (2228)	10 004 (2249)	9986 (2245)	10 124 (2276)	10 084 (2267)	10 133 (2278)	9959 (2239)	10 088 (2268)	9959 (2239)	10 088 (2268)	
Propeller disk power loading, kW/m ² (hp/ft ²)	431 (53.65)	428 (53.27)	421 (52.37)	423 (52.65)	421 (52.46)	420 (52.29)	436 (54.28)	423 (52.71)	434 (54.10)	423 (52.62)	433 (53.89)	423 (52.62)	433 (53.89)	
Nacelle tilt, deg	-1.00	-1.00	-1.00	-1.00	-1.00	-1.00	-1.00	-1.00	-1.00	-1.00	-1.00	-1.00	-1.00	
Attack angle, deg	0.84	0.84	0.78	0.76	0.80	0.83	0.82	0.83	0.83	0.83	0.83	0.86	0.83	
Sideslip angle, deg	0.36	0.34	0.38	-0.13	-0.15	0.24	0.33	0.39	0.36	0.36	-0.29	0.36	0.38	
Power coefficient	1.45	1.45	1.42	1.39	1.39	1.38	1.42	1.39	1.41	1.39	1.41	1.39	1.41	
Thrust coefficient	0.35	0.35	0.35	0.34	0.35	0.35	0.35	0.35	0.35	0.35	0.35	0.35	0.35	
Advance ratio	2.95	2.94	2.91	2.90	2.87	2.87	2.90	2.87	2.89	2.87	2.89	2.87	2.89	

^bSee table V and figure 10 for station-keeping position information.

TABLE IV.—Continued.

(b) Concluded.

Performance	Position ^b													
	Flight													
	6B	6C	6D	6E	6F	7B	7C	7D	7E	7F	7G			
	89-28													
	Run													
	269	268	267	266	265	263	262	261	260	264	259	258		
Flight Mach number	0.702	0.698	0.696	0.703	0.691	0.692	0.694	0.698	0.700	0.701	0.703	0.692		
Altitude, m (ft)	6082 (19 953)	6077 (19 939)	6083 (19 958)	6083 (19 957)	6081 (19 951)	6085 (19 964)	6075 (19 932)	6081 (19 951)	6083 (19 957)	6088 (19 973)	6085 (19 964)	6077 (19 938)		
Propeller power, kW (shaft hp)	3205 (4296)	3199 (4288)	3189 (4275)	3206 (4298)	3188 (4274)	2956 (3962)	2964 (3973)	2974 (3987)	2985 (4002)	2489 (3337)	2988 (4006)	2980 (3994)		
Propeller torque, N-m (ft-lbf)	17 747 (13 090)	17 716 (13 067)	17 682 (13 042)	17 743 (13 087)	17 640 (13 011)	16 342 (12 054)	16 390 (12 089)	16 447 (12 131)	16 506 (12 175)	13 783 (10 166)	16 523 (12 187)	16 467 (12 146)		
Tangential tip Mach number	0.753	0.753	0.752	0.754	0.754	0.755	0.755	0.755	0.755	0.754	0.755	0.756		
Helical tip Mach number	1.030	1.027	1.025	1.031	1.023	1.024	1.025	1.028	1.030	1.030	1.032	1.025		
Propeller thrust, N (lbf)	9892 (2224)	9955 (2238)	9972 (2242)	9866 (2218)	10 093 (2269)	9212 (2071)	9190 (2066)	9150 (2057)	9141 (2055)	7206 (1620)	9096 (2045)	9305 (2092)		
Propeller disk power loading, kW/m ² (hp/ft ²)	426 (53.04)	425 (52.94)	424 (52.78)	426 (53.07)	424 (52.78)	393 (48.92)	394 (49.06)	395 (49.23)	397 (49.41)	331 (41.21)	397 (49.47)	396 (49.32)		
Nacelle tilt, deg	-1.00	-1.00	-1.00	-1.00	-1.00	-1.00	-1.00	-1.00	-1.00	-1.00	-1.00	-1.00		
Attack angle, deg	0.85	0.86	0.86	0.84	0.87	0.88	0.88	0.89	0.88	0.85	0.87	0.89		
Sideslip angle, deg	0.71	0.33	0.44	0.48	0.21	0.29	0.35	0.37	0.36	0.59	0.49	0.42		
Power coefficient	1.44	1.43	1.44	1.44	1.43	1.32	1.32	1.33	1.33	1.12	1.33	1.32		
Thrust coefficient	0.35	0.35	0.35	0.35	0.36	0.32	0.32	0.32	0.32	0.25	0.32	0.33		
Advance ratio	2.93	2.91	2.91	2.93	2.88	2.88	2.89	2.91	2.91	2.92	2.93	2.88		

^bSee table V and figure 10 for station-keeping position information.

TABLE IV.—Continued.

(c) Case 3.

Performance	Position ^b													
	Flight													
	1B	1C	1D	1E	1F	1G	2B	2C						
	89-25													
	Run													
	176	175	174	173	172	334	171	333	186	322	185	89-24	89-25	89-25
Flight Mach number	0.503	0.505	0.504	0.504	0.506	0.515	0.505	0.512	0.505	0.504	0.504	0.504	0.504	0.504
Altitude, m (ft)	6098 (20 007)	6101 (20 017)	6098 (20 007)	6095 (19 997)	6093 (19 991)	6212 (20 379)	6096 (20 000)	6196 (20 327)	6093 (19 991)	6205 (20 369)	6099 (20 010)	6205 (20 369)	6099 (20 010)	6099 (20 010)
Propeller power, kW (shaft hp)	2847 (3816)	2807 (3763)	2813 (3771)	2814 (3772)	2813 (3771)	2874 (3853)	2800 (3753)	2871 (3849)	2810 (3767)	2807 (3763)	2807 (3763)	2807 (3763)	2807 (3763)	2807 (3763)
Propeller torque, N-m (ft-lbf)	15 706 (11 585)	15 494 (11 428)	15 523 (11 450)	15 529 (11 454)	15 525 (11 451)	15 992 (11 796)	15 464 (11 406)	15 973 (11 782)	15 492 (11 427)	15 632 (11 530)	15 480 (11 418)	15 632 (11 530)	15 480 (11 418)	15 480 (11 418)
Tangential tip Mach number	0.755	0.753	0.754	0.754	0.754	0.755	0.753	0.754	0.755	0.753	0.755	0.753	0.755	0.755
Helical tip Mach number	0.907	0.907	0.907	0.907	0.908	0.914	0.907	0.912	0.909	0.906	0.908	0.906	0.908	0.908
Propeller thrust, N (lbf)	12 886 (2897)	12 663 (2847)	12 717 (2859)	12 721 (2860)	12 677 (2850)	12 846 (2888)	12 637 (2841)	12 899 (2900)	12 681 (2851)	12 761 (2869)	12 699 (2855)	12 761 (2869)	12 699 (2855)	12 699 (2855)
Propeller disk power loading, kW/m ² (hp/ft ²)	378 (47.12)	373 (46.46)	374 (46.56)	374 (46.58)	374 (46.56)	382 (47.57)	372 (46.34)	382 (47.52)	373 (46.51)	373 (46.46)	373 (46.46)	373 (46.46)	373 (46.46)	373 (46.46)
Nacelle tilt, deg	-1.00	-1.00	-1.00	-1.00	-1.00	-1.00	-1.00	-1.00	-1.00	-1.00	-1.00	-1.00	-1.00	-1.00
Attack angle, deg	3.08	3.09	3.10	3.11	3.03	3.29	3.04	3.24	2.94	3.78	3.02	3.78	3.02	3.02
Sideslip angle, deg	0.73	0.75	0.66	0.69	0.68	0.90	0.39	0.42	0.89	1.26	0.67	1.26	0.67	0.67
Power coefficient	1.27	1.26	1.26	1.26	1.26	1.31	1.26	1.31	1.25	1.29	1.25	1.29	1.25	1.25
Thrust coefficient	0.46	0.45	0.45	0.45	0.45	0.46	0.45	0.46	0.45	0.46	0.45	0.46	0.45	0.45
Advance ratio	2.10	2.11	2.10	2.10	2.11	2.14	2.11	2.13	2.10	2.11	2.10	2.11	2.10	2.10

^bSee table V and figure 10 for station-keeping position information.

TABLE IV.—Continued.
(c) Continued.

Performance	Position ^b															
	2D		2E		2F		3B		3C		3D		3E		3F	
	89-25		89-34		89-25		89-34		89-25		89-34		89-27		89-27	
	Flight											Run				
	89-25	89-34	89-25	89-34	89-25	89-34	89-25	89-34	89-25	89-34	89-25	89-34	89-25	89-34	89-25	89-34
Flight Mach number	184	321	183	320	182	319	252	251	250	249	248					
Altitude, m (ft)	0.504 (20 018)	0.510 (20 357)	0.503 (19 984)	0.503 (20 381)	0.504 (19 990)	0.507 (20 370)	0.501 (19 894)	0.500 (19 893)	0.502 (19 909)	0.497 (19 888)	0.498 (19 905)					
Propeller power, kW (shaft hp)	2807 (3763)	2824 (3786)	2826 (3788)	2811 (3768)	2818 (3777)	2823 (3784)	2851 (3822)	2850 (3820)	2848 (3818)	2833 (3797)	2833 (3798)					
Propeller torque, N-m (ft-lbf)	15 487 (11 423)	15 735 (11 606)	15 583 (11 494)	15 659 (11 550)	15 544 (11 465)	15 731 (11 603)	15 735 (11 606)	15 724 (11 598)	15 716 (11 592)	15 635 (11 532)	15 636 (11 533)					
Tangential tip Mach number	0.755	0.753	0.756	0.753	0.755	0.753	0.756	0.756	0.756	0.755	0.755					
Helical tip Mach number	0.907	0.910	0.908	0.906	0.908	0.908	0.907	0.906	0.908	0.903	0.904					
Propeller thrust, N (lbf)	12 708 (2857)	12 717 (2859)	12 824 (2883)	12 806 (2879)	12 761 (2869)	12 784 (2874)	12 993 (2921)	13 019 (2927)	12 961 (2914)	12 539 (2819)	12 534 (2818)					
Propeller disk power loading, kW/m ² (hp/ft ²)	373 (46.46)	375 (46.75)	376 (46.77)	374 (46.53)	375 (46.64)	375 (46.72)	379 (47.19)	379 (47.16)	379 (47.14)	377 (46.89)	377 (46.89)					
Nacelle tilt, deg	-1.00	-1.00	-1.00	-1.00	-1.00	-1.00	-1.00	-1.00	-1.00	-1.00	-1.00					
Attack angle, deg	3.05	3.63	3.10	3.91	3.11	3.72	3.39	3.42	3.51	3.62	3.82					
Sideslip angle, deg	0.70	1.09	0.93	1.23	1.10	1.00	1.24	0.99	1.38	1.28	1.40					
Power coefficient	1.25	1.30	1.26	1.29	1.25	1.30	1.26	1.26	1.26	1.26	1.26					
Thrust coefficient	0.45	0.46	0.45	0.46	0.45	0.46	0.46	0.46	0.45	0.46	0.46					
Advance ratio	2.10	2.13	2.09	2.10	2.10	2.12	2.08	2.08	2.09	2.07	2.07					

^bSee table V and figure 10 for station-keeping position information.

TABLE IV.—Continued.

(c) Continued.

Performance	Position ^b									
	4B	4C	4D	4E	4F	4G	5B	5C		
	Flight									
	89-27					89-25				
	Run									
	246	245	244	243	242	241	181	180	338	
Flight Mach number	0.498	0.504	0.500	0.501	0.506	0.496	0.505	0.502	0.510	
Altitude, m (ft)	6060 (19 882)	6073 (19 923)	6067 (19 906)	6068 (19 909)	6072 (19 921)	6060 (19 883)	6091 (19 985)	6095 (19 997)	6208 (20 368)	
Propeller power, kW (shaft hp)	2820 (3780)	2833 (3797)	2826 (3788)	2817 (3776)	2837 (3803)	2827 (3790)	2860 (3834)	2845 (3814)	2866 (3842)	
Propeller torque, N·m (ft·lbf)	15 575 (11 488)	15 644 (11 539)	15 616 (11 518)	15 591 (11 500)	15 681 (11 566)	15 624 (11 524)	15 781 (11 640)	15 705 (11 584)	15 965 (11 776)	
Tangential tip Mach number	0.754	0.755	0.755	0.754	0.755	0.755	0.756	0.755	0.754	
Helical tip Mach number	0.904	0.908	0.906	0.905	0.909	0.904	0.910	0.907	0.911	
Propeller thrust, N (lbf)	12 913 (2903)	12 828 (2884)	12 886 (2897)	12 824 (2883)	12 815 (2881)	13 002 (2923)	12 957 (2913)	12 926 (2906)	12 913 (2903)	
Propeller disk power loading, kW/m ² (hp/ft ²)	375 (46.67)	376 (46.88)	376 (46.77)	374 (46.63)	377 (46.96)	375 (46.76)	380 (47.34)	378 (47.10)	381 (47.44)	
Nacelle tilt, deg	-1.00	-1.00	-1.00	-1.00	-1.00	-1.00	-1.00	-1.00	-1.00	
Attack angle, deg	3.74	3.42	3.55	3.51	3.41	3.76	3.05	3.13	3.29	
Sideslip angle, deg	1.15	1.09	0.95	0.93	1.25	1.08	0.89	0.71	0.64	
Power coefficient	1.25	1.26	1.26	1.26	1.26	1.26	1.27	1.27	1.31	
Thrust coefficient	0.45	0.45	0.45	0.45	0.45	0.46	0.46	0.46	0.46	
Advance ratio	1.25	1.26	1.26	1.26	1.26	1.26	1.26	1.26	1.26	

^bSee table V and figure 10 for station-keeping position information.

TABLE IV.—Continued.
(c) Continued.

Performance	Position ^b																			
	5D						5E						5F							
	89-25		89-34		89-25		89-34		89-25		89-34		89-25		89-34		89-25		89-34	
	179	337	178	336	177	335	239	238	237	236	235	235	236	237	238	239	238	237	236	235
Flight Mach number	0.504	0.515	0.503	0.516	0.506	0.512	0.498	0.501	0.498	0.503	0.501	0.498	0.501	0.498	0.498	0.501	0.498	0.498	0.503	0.501
Altitude, m (ft)	6101 (20 015)	6213 (20 383)	6090 (19 979)	6209 (20 372)	6094 (19 995)	6205 (20 359)	6054 (19 863)	6064 (19 895)	6054 (19 863)	6063 (19 891)	6064 (19 895)	6054 (19 863)	6064 (19 895)	6059 (19 878)	6064 (19 895)	6054 (19 863)	6059 (19 878)	6063 (19 891)	6063 (19 891)	6060 (19 881)
Propeller power, kW (shaft hp)	2842 (3809)	2859 (3832)	2833 (3798)	2872 (3850)	2849 (3819)	2871 (3849)	2787 (3736)	2800 (3753)	2787 (3736)	2798 (3751)	2800 (3753)	2787 (3736)	2800 (3753)	2795 (3747)	2800 (3753)	2787 (3736)	2795 (3747)	2798 (3751)	2798 (3751)	2795 (3746)
Propeller torque, N-m (ft-lbf)	15 681 (11 566)	15 948 (11 763)	15 632 (11 530)	15 980 (11 787)	15 717 (11 593)	15 963 (11 774)	15 423 (11 376)	15 489 (11 425)	15 423 (11 376)	15 848 (11 421)	15 489 (11 425)	15 423 (11 376)	15 489 (11 425)	15 464 (11 406)	15 489 (11 425)	15 423 (11 376)	15 464 (11 406)	15 848 (11 421)	15 848 (11 421)	15 461 (11 404)
Tangential tip Mach number	0.755	0.753	0.754	0.755	0.755	0.755	0.754	0.754	0.755	0.754	0.754	0.754	0.754	0.755	0.754	0.754	0.755	0.754	0.754	0.754
Helical tip Mach number	0.908	0.913	0.907	0.915	0.909	0.913	0.904	0.906	0.913	0.906	0.906	0.904	0.906	0.904	0.906	0.904	0.904	0.906	0.906	0.906
Propeller thrust, N (lbf)	12 864 (2892)	12 775 (2872)	12 828 (2884)	12 815 (2881)	12 841 (2887)	12 904 (2901)	12 770 (2871)	12 766 (2870)	12 904 (2901)	12 819 (2862)	12 721 (2860)	12 766 (2870)	12 770 (2871)	12 766 (2870)	12 819 (2862)	12 766 (2870)	12 770 (2871)	12 819 (2862)	12 721 (2860)	12 739 (2864)
Propeller disk power loading, kW/m ² (hp/ft ²)	378 (47.03)	380 (47.32)	377 (46.89)	382 (47.54)	379 (47.15)	382 (47.53)	370 (46.13)	372 (46.34)	382 (47.53)	372 (46.31)	372 (46.31)	370 (46.13)	372 (46.34)	372 (46.27)	372 (46.31)	370 (46.13)	372 (46.34)	372 (46.27)	372 (46.31)	371 (46.26)
Nacelle tilt, deg	-1.00	-1.00	-1.00	-1.00	-1.00	-1.00	-1.00	-1.00	-1.00	-1.00	-1.00	-1.00	-1.00	-1.00	-1.00	-1.00	-1.00	-1.00	-1.00	-1.00
Attack angle, deg	3.09	3.21	3.11	3.13	3.06	3.27	3.70	3.66	3.27	3.70	3.66	3.70	3.66	3.75	3.66	3.70	3.75	3.62	3.65	
Sideslip angle, deg	0.73	0.72	0.89	0.72	0.80	0.73	0.99	1.03	0.73	0.99	1.03	0.99	1.03	1.09	1.03	0.99	1.09	0.95	1.02	
Power coefficient	1.27	1.32	1.26	1.31	1.27	1.31	1.24	1.25	1.31	1.25	1.25	1.24	1.25	1.25	1.25	1.24	1.25	1.25	1.25	1.25
Thrust coefficient	0.45	0.46	0.45	0.46	0.45	0.46	0.45	0.45	0.46	0.45	0.45	0.45	0.45	0.45	0.45	0.45	0.45	0.45	0.45	0.45
Advance ratio	2.10	2.15	1.26	2.15	1.27	2.13	2.08	2.09	2.13	2.10	2.09	2.08	2.09	2.08	2.09	2.08	2.08	2.10	2.10	2.09

^bSee table V and figure 10 for station-keeping position information.

TABLE IV.—Continued.
(c) Concluded.

Performance	Position ^b							
	7B	7C	7D	7E	7F	7G		
	Flight							
	89-27							
	Run							
	234	233	232	231	240	230	229	
Flight Mach number	0.497	0.498	0.498	0.503	0.504	0.503	0.497	
Altitude, m (ft)	6055 (19 867)	6062 (19 888)	6073 (19 925)	6058 (19 876)	6068 (19 908)	6058 (19 907)	6055 (19 865)	
Propeller power, kW (shaft hp)	2787 (3736)	2784 (3732)	2782 (3729)	2775 (3720)	2442 (3274)	2771 (3715)	2768 (3711)	
Propeller torque, N-m (ft-lbf)	15 414 (11 369)	15 404 (11 362)	15 389 (11 351)	15 367 (11 335)	13 505 (9961)	15 347 (11 320)	15 354 (11 325)	
Tangential tip Mach number	0.754	0.753	0.754	0.752	0.755	0.752	0.752	
Helical tip Mach number	0.903	0.903	0.903	0.905	0.908	0.905	0.901	
Propeller thrust, N (lbf)	12 801 (2878)	12 761 (2869)	12 757 (2868)	12 597 (2832)	11 133 (2503)	12 574 (2827)	12 703 (2856)	
Propeller disk power loading, kW/m ² (hp/ft ²)	370 (46.13)	370 (46.08)	370 (46.14)	369 (45.94)	325 (40.43)	368 (45.88)	368 (45.82)	
Nacelle tilt, deg	-1.00	-1.00	-1.00	-1.00	-1.00	-1.00	-1.00	
Attack angle, deg	3.85	3.88	3.78	3.59	3.45	3.61	3.38	
Sideslip angle, deg	0.84	0.82	0.80	1.13	1.02	1.08	1.09	
Power coefficient	1.24	1.24	1.24	1.24	1.09	1.24	1.24	
Thrust coefficient	0.45	0.45	0.45	0.45	0.39	0.45	0.45	
Advance ratio	2.07	2.08	2.08	2.10	2.10	2.10	2.08	

^bSee table V and figure 10 for station-keeping position information.

TABLE IV.—Continued.
(d) Case 4.

Performance	Position ^b										
	Flight										
	1B	1C	1D	1E	1F	1G	5C	5E	5F		
	89-25					89-34					89-23
	Run										
	164	163	162	161	160	314	159	313	318	316	315
Flight Mach number	0.505	0.504	0.507	0.507	0.503	0.503	0.504	0.507	0.506	0.508	0.503
Altitude, m (ft)	4271 (14 013)	4271 (14 014)	4264 (13 991)	4274 (14 022)	4268 (14 003)	4336 (14 226)	4269 (14 005)	4328 (14 199)	4352 (14 277)	4338 (14 231)	4329 (14 204)
Propeller power, kW (shaft hp)	3240 (4343)	3246 (4351)	3244 (4349)	3245 (4350)	3176 (4257)	3257 (4366)	3067 (4111)	3159 (4235)	3309 (4436)	3276 (4391)	3255 (4363)
Propeller torque, N-m (ft-lbf)	17 958 (13 246)	17 989 (13 269)	17 992 (13 271)	17 998 (13 275)	17 652 (13 020)	17 630 (13 004)	17 001 (12 540)	17 088 (12 604)	17 956 (13 244)	17 737 (13 083)	17 619 (12 996)
Tangential tip Mach number	0.736	0.736	0.736	0.736	0.734	0.756	0.736	0.756	0.753	0.755	0.755
Helical tip Mach number	0.893	0.892	0.894	0.894	0.890	0.908	0.892	0.910	0.908	0.911	0.908
Propeller thrust, N (lbf)	14 327 (3221)	14 385 (3234)	14 278 (3210)	14 278 (3210)	14 082 (3166)	14 554 (3272)	13 606 (3059)	14 025 (3153)	14 670 (3298)	14 496 (3259)	14 532 (3267)
Propeller disk power loading, kW/m ² (hp/ft ²)	431 (53.63)	431 (53.72)	431 (53.70)	431 (53.70)	422 (52.57)	433 (53.91)	408 (50.75)	420 (52.29)	440 (54.77)	435 (54.21)	433 (53.87)
Nacelle tilt, deg	-1.00	-1.00	-1.00	-1.00	-1.00	-1.00	-1.00	-1.00	-1.00	-1.00	-1.00
Attack angle, deg	2.08	2.10	2.06	2.07	2.11	2.54	2.12	2.47	2.48	2.53	2.64
Sideslip angle, deg	0.68	0.34	0.47	0.35	0.37	0.93	0.11	1.29	0.80	1.03	1.08
Power coefficient	1.19	1.20	1.20	1.20	1.18	1.12	1.13	1.09	1.15	1.13	1.12
Thrust coefficient	0.42	0.42	0.41	.042	0.41	0.40	0.40	0.39	0.41	0.40	0.40
Advance ratio	2.16	2.15	2.17	2.17	2.16	2.09	2.15	2.11	2.11	2.11	2.09

^bSee table V and figure 10 for station-keeping position information.

TABLE IV.—Continued.
(d) Concluded.

Performance	Position ^b														
	6C	6D	6E	6F	7B	7C	7D	7E	7F	7G					
	Flight														
89-27															
Run															
	228	227	226	225	223	222	221	220	224	219	218				
Flight Mach number	0.508	0.504	0.499	0.500	0.507	0.507	0.502	0.501	0.503	0.504	0.504	0.504			
Altitude, m (ft)	4261 (13 979)	4260 (13 976)	4257 (13 965)	4252 (13 951)	4262 (13 982)	4264 (13 988)	4257 (13 967)	4260 (13 978)	4262 (13 982)	4266 (13 997)	4252 (13 951)	4252 (13 951)			
Propeller power, kW (shaft hp)	3170 (4249)	3165 (4242)	3129 (4195)	3138 (4207)	3130 (4196)	3129 (4195)	2995 (4015)	2966 (3976)	3138 (4207)	2978 (3992)	2976 (3989)	2976 (3989)			
Propeller torque, N-m (ft-lbf)	17 520 (12 923)	17 496 (12 905)	17 314 (12 771)	17 351 (12 798)	17 343 (12 792)	17 339 (12 789)	16 590 (12 237)	16 434 (12 122)	17 383 (12 822)	16 487 (12 161)	16 455 (12 137)	16 455 (12 137)			
Tangential tip Mach number	0.738	0.737	0.737	0.737	0.735	0.735	0.735	0.734	0.735	0.735	0.735	0.735			
Helical tip Mach number	0.896	0.893	0.890	0.891	0.893	0.893	0.890	0.889	0.891	0.891	0.891	0.891			
Propeller thrust, N (lbf)	13 940 (3134)	14 020 (3152)	13 989 (3145)	13 993 (3146)	13 762 (3094)	13 758 (3093)	13 291 (2988)	13 193 (2966)	13 900 (3125)	13 166 (2960)	13 144 (2955)	13 144 (2955)			
Propeller disk power loading, kW/m ² (hp/ft ²)	421 (52.46)	421 (52.38)	416 (51.80)	417 (51.95)	416 (51.81)	416 (51.80)	398 (49.57)	394 (49.09)	417 (51.94)	396 (49.29)	396 (49.26)	396 (49.26)			
Nacelle tilt, deg	-1.00	-1.00	-1.00	-1.00	-1.00	-1.00	-1.00	-1.00	-1.00	-1.00	-1.00	-1.00			
Attack angle, deg	2.21	2.32	2.49	2.41	2.22	2.27	2.39	2.43	2.25	2.30	2.28	2.28			
Sideslip angle, deg	0.81	0.96	0.91	0.87	0.72	0.65	0.63	0.62	0.88	0.47	0.93	0.93			
Power coefficient	1.16	1.16	1.15	1.15	1.16	1.16	1.11	1.10	1.16	1.10	1.09	1.09			
Thrust coefficient	0.40	0.41	0.41	0.40	0.40	0.40	0.39	0.38	0.40	0.38	0.38	0.38			
Advance ratio	2.16	2.15	2.13	2.13	2.17	2.17	2.15	2.14	2.15	2.16	2.16	2.16			

^bSee table V and figure 10 for station-keeping position information.

TABLE IV.—Continued.

(e) Case 6.

Performance	Position ^b									
	89-26									
	ID	1E	1F	7B	7C	7D	7E	7F	7G	7G
	89-23									
	Flight									
	Run									
	134	133	132	215	214	213	212	211	210	210
Flight Mach number	0.762	0.763	0.759	0.760	0.766	0.770	0.765	0.755	0.768	0.768
Altitude, m (ft)	10 661 (34 997)	10 659 (34 970)	10 653 (34 951)	10 661 (34 978)	10 662 (34 980)	10 659 (34 970)	10 657 (34 963)	10 656 (34 961)	10 658 (34 966)	10 658 (34 966)
Propeller power, kW (shaft hp)	2098 (2813)	2091 (2803)	2081 (2789)	2093 (2805)	2108 (2826)	2118 (2839)	2094 (2807)	2093 (2805)	2108 (2826)	2108 (2826)
Propeller torque, N-m (ft-lbf)	11 377 (8392)	11 337 (8362)	11 277 (8318)	11 354 (8375)	11 432 (8434)	11 489 (8474)	11 369 (8386)	11 348 (8370)	11 447 (8443)	11 447 (8443)
Tangential tip Mach number	0.836	0.837	0.837	0.835	0.835	0.835	0.835	0.835	0.834	0.834
Helical tip Mach number	1.132	1.132	1.130	1.129	1.134	1.137	1.133	1.127	1.135	1.135
Propeller thrust, N (lbf)	6668 (1499)	6632 (1491)	6628 (1490)	6668 (1499)	6650 (1495)	6636 (1492)	6605 (1485)	6725 (1512)	6619 (1488)	6619 (1488)
Propeller disk power loading, kW/m ² (hp/ft ²)	279 (34.74)	278 (34.62)	277 (34.44)	278 (34.64)	280 (34.90)	282 (35.06)	278 (34.66)	278 (34.64)	280 (34.90)	280 (34.90)
Nacelle tilt, deg	-1.00	-1.00	-1.00	-1.00	-1.00	-1.00	-1.00	-1.00	-1.00	-1.00
Attack angle, deg	1.53	1.56	1.62	1.56	1.58	1.58	1.58	1.76	1.68	1.68
Sideslip angle, deg	0.26	0.34	0.28	0.34	0.44	0.49	0.58	0.56	0.91	0.91
Power coefficient	1.46	1.46	1.45	1.47	1.47	1.48	1.47	1.46	1.48	1.48
Thrust coefficient	0.37	0.37	0.37	0.38	0.37	0.37	0.37	0.38	0.37	0.37
Advance ratio	2.86	2.87	2.85	2.86	2.88	2.90	2.88	2.84	2.90	2.90

^bSee table V and figure 10 for station-keeping position information.

TABLE IV.—Continued.
(f) Case 7.

Performance	Position ^b										
	Flight										
	1B	1C	1D	1E	1F	1G	5C	5D	5E		
	89-23					89-23					89-33
	Run										
	131	130	129	128	127	299	126	298	303	302	301
Flight Mach number	0.703	0.701	0.704	0.702	0.700	0.703	0.706	0.705	0.710	0.709	0.709
Altitude, m (ft)	10 677 (35 029)	10 668 (34 999)	10 671 (35 009)	10 662 (34 979)	10 660 (34 975)	10 806 (35 453)	10 661 (34 976)	10 814 (35 480)	10 810 (35 466)	10 806 (35 454)	10 810 (35 466)
Propeller power, kW (shaft hp)	1807 (2422)	1806 (2421)	1808 (2423)	1800 (2413)	1799 (2411)	1811 (2427)	1799 (2411)	1818 (2437)	1829 (2452)	1836 (2461)	1831 (2455)
Propeller torque, N·m (ft·lbf)	11 364 (8382)	11 384 (8397)	11 391 (8402)	11 494 (8478)	11 344 (8367)	33 262 (8307)	11 353 (8374)	11 321 (8350)	11 373 (8389)	11 425 (8427)	11 402 (8410)
Tangential tip Mach number	0.722	0.720	0.720	0.719	0.719	0.723	0.718	0.722	0.723	0.723	0.722
Helical tip Mach number	1.008	1.005	1.007	1.005	1.004	1.008	1.007	1.010	1.013	1.013	1.013
Propeller thrust, N (lbf)	6214 (1397)	6227 (1400)	6196 (1393)	6196 (1393)	6209 (1396)	6169 (1387)	6138 (1380)	6174 (1388)	6165 (1386)	6201 (1394)	6178 (1389)
Propeller disk power loading, kW/m ² (hp/ft ²)	240 (29.91)	240 (29.89)	240 (29.91)	239 (29.80)	239 (29.77)	241 (29.97)	239 (29.77)	242 (30.09)	243 (30.28)	244 (30.39)	243 (30.32)
Nacelle tilt, deg	-1.00	-1.00	-1.00	-1.00	-1.00	-1.00	-1.00	-1.00	-1.00	-1.00	-1.00
Attack angle, deg	2.46	2.50	2.46	2.53	2.52	3.03	2.42	3.00	2.69	2.79	2.78
Sideslip angle, deg	0.08	0.08	0.13	0.20	0.00	0.50	0.12	0.30	0.30	0.36	0.37
Power coefficient	1.97	1.98	1.98	1.97	1.97	1.98	1.98	2.00	2.00	2.01	2.01
Thrust coefficient	0.47	0.47	0.47	0.47	0.47	0.47	0.47	0.48	0.47	0.48	0.48
Advance ratio	3.06	3.06	3.08	3.07	3.06	3.06	3.09	3.07	3.09	3.08	3.09

^bSee table V and figure 10 for station-keeping position information.

TABLE IV.—Continued.

(f) Concluded.

Performance	Position ^b									
	Flight									
	5F	7B	7C	7D	7E	7F	7G			
	89-33									
	89-26									
	Run									
	300	198	197	196	195	194	193			
Flight Mach number	0.703	0.705	0.703	0.701	0.707	0.698	0.706			
Altitude, m (ft)	10 809 (35 464)	10 656 (34 962)	10 658 (34 967)	10 657 (34 964)	10 659 (34 969)	10 655 (34 956)	10 666 (34 993)			
Propeller power, kW (shaft hp)	1821 (2441)	1837 (2463)	1832 (2456)	1821 (2441)	1825 (2447)	1825 (2446)	1830 (2453)			
Propeller torque, N-m (ft-lbf)	11 339 (8364)	11 542 (8513)	11 513 (8492)	11 452 (8477)	11 486 (8472)	11 464 (8456)	11 502 (8484)			
Tangential tip Mach number	0.722	0.721	0.721	0.720	0.719	0.721	0.720			
Helical tip Mach number	1.008	1.008	1.007	1.005	1.009	1.004	1.009			
Propeller thrust, N (lbf)	6201 (1394)	6298 (1416)	6298 (1416)	6276 (1411)	6223 (1399)	6321 (1421)	6249 (1405)			
Propeller disk power loading, kW/m ² (hp/ft ²)	242 (30.14)	244 (30.41)	244 (30.33)	242 (30.15)	243 (30.22)	243 (30.21)	243 (30.29)			
Nacelle tilt, deg	-1.00	-1.00	-1.00	-1.00	-1.00	-1.00	-1.00			
Attack angle, deg	2.90	2.59	2.63	2.66	2.60	2.78	2.62			
Sideslip angle, deg	0.25	0.62	0.69	0.62	0.67	0.65	0.37			
Power coefficient	2.00	1.99	1.99	1.98	1.99	1.98	1.99			
Thrust coefficient	0.48	0.48	0.48	0.47	0.47	0.48	0.47			
Advance ratio	3.06	3.07	3.06	3.06	3.09	3.04	3.08			

^bSee table V and figure 10 for station-keeping position information.

TABLE IV.—Continued.
(g) Case 8.

Performance	Position ^b											
	Flight											
	89-23			89-33			89-23			89-33		
	Run											
	1B	1C	1D	1E	1F	1G	5C	5D	5E			
	125	124	123	122	121	305	120	304	309	308	307	
Flight Mach number	0.702	0.701	0.706	0.702	0.699	0.704	0.700	0.712	0.707	0.705	0.702	
Altitude, m (ft)	10 659 (34 970)	10 655 (34 956)	10 661 (34 978)	10 656 (34 959)	10 655 (34 958)	10 803 (35 443)	10 656 (34 961)	10 813 (35 477)	10 814 (35 478)	10 807 (35 455)	10 800 (35 433)	
Propeller power, kW (shaft hp)	1822 (2443)	1820 (2440)	1824 (2445)	1825 (2447)	1823 (2444)	1771 (2374)	1822 (2442)	1772 (2375)	1779 (2385)	1767 (2369)	1767 (2369)	
Propeller torque, N-m (ft-lbf)	12 333 (9097)	12 332 (9096)	12 369 (9123)	12 358 (9115)	12 355 (9113)	11 844 (8736)	12 351 (9110)	11 851 (8741)	11 887 (8768)	11 810 (8711)	11 813 (8713)	
Tangential tip Mach number	0.669	0.669	0.669	0.669	0.669	0.672	0.669	0.672	0.673	0.673	0.672	
Helical tip Mach number	0.970	0.969	0.973	0.971	0.968	0.974	0.969	0.979	0.976	0.975	0.972	
Propeller thrust, N (lbf)	6103 (1372)	6107 (1373)	6054 (1361)	6116 (1375)	6147 (1382)	5854 (1316)	6129 (1378)	5760 (1295)	5845 (1314)	5831 (1311)	5876 (1321)	
Propeller disk power loading, kW/m ² (hp/ft ²)	242 (30.16)	242 (30.13)	242 (30.19)	243 (30.21)	242 (30.18)	235 (29.32)	242 (30.15)	235 (29.32)	236 (29.45)	235 (29.25)	235 (29.26)	
Nacelle tilt, deg	-1.00	-1.00	-1.00	-1.00	-1.00	-1.00	-1.00	-1.00	-1.00	-1.00	-1.00	
Attack angle, deg	2.50	2.67	2.62	2.75	2.88	2.72	2.87	2.61	2.63	2.74	2.80	
Sideslip angle, deg	0.06	0.01	0.15	0.12	-0.07	-0.01	-0.03	0.24	0.05	-0.13	-0.06	
Power coefficient	2.47	2.48	2.49	2.48	2.48	2.41	2.48	2.41	2.42	2.40	2.40	
Thrust coefficient	0.53	0.54	0.53	0.54	0.54	0.52	0.54	0.51	0.52	0.52	0.52	
Advance ratio	3.30	3.29	3.32	3.30	3.28	3.29	3.29	3.33	3.31	3.29	3.28	

^bSee table V and figure 10 for station-keeping position information.

TABLE IV.—Continued.
(g) Concluded.

Performance	Position ^b						
	5F	7B	7C	7D	7E	7F	7G
	Flight						
	89-26						
	Run						
	306	192	191	190	189	188	187
Flight Mach number	0.706	0.700	0.714	0.706	0.710	0.698	0.699
Altitude, m (ft)	10 808 (35 458)	10 662 (34 980)	10 666 (34 993)	10 653 (34 951)	10 665 (34 990)	10 667 (34 998)	10 965 (35 973)
Propeller power, kW (shaft hp)	1775 (2380)	1828 (2450)	1851 (2481)	1825 (2447)	1834 (2459)	1828 (2450)	1823 (2444)
Propeller torque, N·m (ft-lbf)	11 866 (8752)	12 341 (9103)	12 492 (9214)	12 356 (9114)	12 408 (9152)	12 363 (9119)	12 347 (9107)
Tangential tip Mach number	0.673	0.670	0.671	0.669	0.669	0.669	0.688
Helical tip Mach number	0.976	0.969	0.979	0.973	0.976	0.968	0.967
Propeller thrust, N (lbf)	5845 (1314)	6143 (1381)	6067 (1364)	6049 (1360)	6027 (1355)	6156 (1384)	6129 (1378)
Propeller disk power loading, kW/m ² (hp/ft ²)	236 (29.39)	243 (30.25)	246 (30.64)	243 (30.21)	244 (30.37)	243 (30.26)	242 (30.17)
Nacelle tilt, deg	-1.00	-1.00	-1.00	-1.00	-1.00	-1.00	-1.00
Attack angle, deg	2.72	2.79	2.62	2.78	2.73	3.02	3.01
Sideslip angle, deg	0.0	-0.17	-0.35	0.42	0.79	0.76	0.41
Power coefficient	2.41	2.47	2.50	2.48	2.49	2.48	2.49
Thrust coefficient	0.52	0.53	0.53	0.53	0.53	0.54	0.54
Advance ratio	3.30	3.28	3.34	3.32	3.34	3.28	3.29

^bSee table V and figure 10 for station-keeping position information.

TABLE V.—LEARJET STATION-KEEPING POSITIONS ^a

(a) Case 1

Learjet microphone	Position																					
	1B				1C				1D				1E									
	Run																					
	106	142	105	109	141	104	108	140	103	107	139											
	Sideline angle, ^b deg																					
Nose	60	58	73	74	74	89	89	86	105	104	103											
Wingtip	--	--	--	--	--	--	--	--	--	--	--											
Cabin roof	61	59	74	74	74	90	89	87	106	105	104											
	Azimuthal angle, ^c deg																					
Nose	0	1R	1R	7L	2R	0	0	1R	0	1L	0											
Wingtip	-	--	--	--	--	-	-	--	-	--	-											
Cabin roof	0	1R	1R	7L	2R	0	0	1R	0	1L	0											
	Distance ^d																					
	m	ft	m	ft	m	ft	m	ft	m	ft	m	ft	m	ft								
Nose	198	648	224	734	185	607	471	1545	200	655	162	530	490	1607	184	603	167	548	491	1611	172	563
Wingtip	---	---	---	---	---	---	---	---	---	---	---	---	---	---	---	---	---	---	---	---	---	---
Cabin roof	195	641	221	726	184	604	471	1545	200	655	162	530	490	1607	183	602	168	551	493	1618	172	565

^aDashes indicate that no data were available.

^bRelative to propeller plane axis.

^cDegrees left (L) and right (R) of center.

^dMicrophone to propeller plane axis.

TABLE V.—Continued.
(a) Continued.

Learjet microphone	Position																								
	1F			1G			2B			2C			2D			2E									
	Run																								
	102	138	289	101	288	119	118	297	117	296	116	295													
	Sideline angle, ^b deg																								
Nose	122	119	121	137	135	66	74	74	90	91	103	104													
Wingtip	---	---	---	---	---	---	---	---	---	---	---	---													
Cabin roof	123	120	124	138	138	67	75	78	91	94	103	107													
	Azimuthal angle, ^c deg																								
Nose	0	2L	3R	1R	3R	31R	27R	39R	28R	37R	31R	36R													
Wingtip	-	--	--	--	--	---	---	---	---	---	---	---													
Cabin roof	0	2L	3R	1R	3R	31R	27R	39R	28R	37R	31R	36R													
	Distance ^d																								
	m	ft	m	ft	m	ft	m	ft	m	ft	m	ft	m	ft	m	ft	m	ft							
Nose	202	662	185	606	41	135	252	832	40	132	192	630	158	518	37	122	152	500	42	139	157	514	37	121	
Wingtip	---	---	---	---	--	---	---	---	--	---	---	---	---	---	---	---	---	---	---	---	---	---	---	---	---
Cabin roof	204	669	187	612	42	139	258	848	42	139	192	630	158	518	37	120	152	500	43	140	157	514	37	123	

^bRelative to propeller plane axis.

^cDegrees left (L) and right (R) of center.

^dMicrophone to propeller plane axis.

TABLE V.—Continued.
(a) Continued.

Learjet microphone	Position											
	Run						Run					
	2F	5B	5C	5D	5E	5F	6B	5D	5E	5F	5G	6B
	115	294	114	113	293	112	292	111	291	110	290	209
	Sideline angle, ^b deg											
Nose	119	120	60	75	68	90	86	104	104	119	122	58
Wingtip	---	---	--	--	--	--	--	---	---	---	---	60
Cabin roof	119	123	60	75	72	91	90	105	109	120	126	--
	Azimuthal angle, ^c deg											
Nose	33R	33R	27L	26L	36L	26L	39L	34L	34L	31L	33L	60L
Wingtip	---	---	---	---	---	---	---	---	---	---	---	60L
Cabin roof	33R	33R	27L	26L	36L	26L	39L	34L	34L	31L	33L	---
	Distance ^d											
	m	ft	m	ft	m	ft	m	ft	m	ft	m	ft
Nose	176	577	42	138	185	608	203	667	36	118	165	542
Wingtip	---	---	--	---	---	---	---	---	---	---	---	---
Cabin roof	176	577	44	143	185	608	203	667	35	115	165	542
	m	ft	m	ft	m	ft	m	ft	m	ft	m	ft
Nose	176	577	42	138	185	608	203	667	36	118	165	542
Wingtip	---	---	--	---	---	---	---	---	---	---	---	---
Cabin roof	176	577	44	143	185	608	203	667	35	115	165	542
	m	ft	m	ft	m	ft	m	ft	m	ft	m	ft
Nose	176	577	42	138	185	608	203	667	36	118	165	542
Wingtip	---	---	--	---	---	---	---	---	---	---	---	---
Cabin roof	176	577	44	143	185	608	203	667	35	115	165	542

^bRelative to propeller plane axis.

^cDegrees left (L) and right (R) of center.

^dMicrophone to propeller plane axis.

TABLE V.—Continued.
(a) Concluded.

Learjet microphone	Position																			
	Run																			
	6C	6D	6E	6F	7B	7C	7D	7E	7F	7G										
	208	207	206	205	204	203	202	201	200	199										
	Sideline angle, ^b deg																			
Nose	73	90	104	117	57	68	86	103	118	134										
Wingtip	77	95	109	123	60	73	91	108	126	141										
Cabin roof	---	---	---	---	--	--	--	---	---	---										
	Azimuthal angle, ^c deg																			
Nose	60L	60L	60L	60L	90L	90L	90L	90L	90L	90L										
Wingtip	60L	60L	60L	60L	90L	90L	90L	90L	90L	90L										
Cabin roof	---	---	---	---	---	---	---	---	---	---										
	Distance ^d																			
	m	ft	m	ft	m	ft	m	ft	m	ft	m	ft	m	ft						
Nose	93	304	88	290	84	277	88	289	75	245	58	191	91	297	80	263	62	202	66	217
Wingtip	86	282	84	274	81	267	87	286	67	219	51	167	85	279	77	253	61	200	68	223
Cabin roof	---	---	---	---	---	---	---	---	---	---	---	---	---	---	---	---	---	---	---	---

^bRelative to propeller plane axis.

^cDegrees left (L) and right (R) of center.

^dMicrophone to propeller plane axis.

TABLE V.—Continued.
(b) Case 2

Learjet microphone	Position																						
	1B	1C	1D	1E	1F	1G	2B	2C															
	151	148	147	146	145	328	144	327	169	168	326												
	Run																						
	Sideline angle, ^b deg																						
Nose	59	76	91	106	122	117	136	132	63	77	73												
Wingtip	--	--	--	---	---	---	---	---	--	--	--												
Cabin roof	60	77	92	107	122	120	136	135	63	77	79												
	Azimuthal angle, ^c deg																						
Nose	1R	3R	2L	0	0	2R	0	4R	29R	27R	35R												
Wingtip	--	--	--	-	-	--	-	--	---	---	---												
Cabin roof	1R	3R	2L	0	0	2R	0	4R	29R	27R	35R												
	Distance ^d																						
	m	ft	m	ft	m	ft	m	ft	m	ft	m	ft											
Nose	199	654	178	585	163	536	172	564	211	693	50	164	293	960	50	165	268	879	242	795	28	92	
Wingtip	---	---	---	---	---	---	---	---	---	---	---	---	---	---	---	---	---	---	---	---	---	---	---
Cabin roof	198	648	177	582	163	536	173	567	211	693	51	168	293	960	53	174	268	879	242	795	27	90	

^bRelative to propeller plane axis.

^cDegrees left (L) and right (R) of center.

^dMicrophone to propeller plane axis.

TABLE V.—Continued.
(b) Continued.

Learjet microphone	Position																							
	2D			2E			2F			3C			3D											
	167	325	158	166	170	324	157	165	323	278	277	276												
	Run																							
	Sideline angle, ^b deg																							
Nose	92	85	104	104	103	100	121	119	117	60	N.A.	87												
Wingtip	--	--	---	---	---	---	---	---	---	63	N.A.	94												
Cabin roof	92	89	105	105	104	103	122	120	119	--	----	--												
	Azimuthal angle, ^c deg																							
Nose	27R	37R	35R	32R	31R	38R	31R	30R	29R	60R	60R	60R												
Wingtip	---	---	---	---	---	---	---	---	---	60R	60R	60R												
Cabin roof	27R	37R	35R	32R	31R	38R	31R	30R	29R	--	---	---												
	Distance ^d																							
	m	ft	m	ft	m	ft	m	ft	m	ft	m	ft												
Nose	236	775	35	114	157	516	214	703	254	832	44	143	179	587	217	711	50	164	76	249	---	62	204	
Wingtip	---	---	--	---	---	---	---	---	---	---	---	---	---	---	---	---	---	---	---	---	---	---	58	189
Cabin roof	236	775	34	113	157	516	215	706	255	836	44	145	179	587	219	719	51	167	68	224	---	--	---	

^bRelative to propeller plane axis.

^cDegrees left (L) and right (R) of center.

^dMicrophone to propeller plane axis.

TABLE V.—Continued.
(b) Continued.

Learjet microphone	Position											
	3E	3F	4B	4C	4D	4E	4F					
	275	274	273	272	257	271	282	256	270	281	255	280
	Run											
	Sideline angle, ^b deg											
Nose	101	114	61	73	87	87	87	99	100	101	113	114
Wingtip	109	124	65	79	95	95	95	110	110	109	124	124
Cabin roof	---	---	--	---	--	--	--	---	---	---	---	---
	Azimuthal angle, ^c deg											
Nose	60R	---	90R	90R	90R	90R	90R	90R	90R	90R	90R	90R
Wingtip	60R	---	90R	90R	90R	90R	90R	90R	90R	90R	90R	90R
Cabin roof	---	---	---	---	---	---	---	---	---	---	---	---
	Distance ^d											
	m	ft	m	ft	m	ft	m	ft	m	ft	m	ft
Nose	54	177	52	172	52	172	57	186	48	156	57	188
Wingtip	51	168	52	169	48	157	52	171	45	147	55	179
Cabin roof	--	---	--	---	--	---	--	---	--	---	--	---
	m	ft	m	ft	m	ft	m	ft	m	ft	m	ft
Nose	54	177	52	172	52	172	57	186	48	156	57	188
Wingtip	51	168	52	169	48	157	52	171	45	147	55	179
Cabin roof	--	---	--	---	--	---	--	---	--	---	--	---

^bRelative to propeller plane axis.

^cDegrees left (L) and right (R) of center.

^dMicrophone to propeller plane axis.

TABLE V.—Continued.
(b) Continued.

Learjet microphone	Position																						
	4G		5B	5C	5D	5E		5F															
	254	279	156	155	154	331	153	330	332	152	329												
	Run																						
	Sideline angle, ^b deg																						
Nose	128	129	60	75	89	88	105	104	75	122	116												
Wingtip	138	138	--	--	--	--	--	--	--	--	--												
Cabin roof	--	--	61	76	90	92	106	108	78	123	118												
	Azimuthal angle, ^c deg																						
Nose	90R	90R	30L	31L	27L	26L	32L	27L	30L	31L	27L												
Wingtip	90R	90R	--	--	--	--	--	--	--	--	--												
Cabin roof	--	--	30L	31L	27L	26L	32L	27L	30L	31L	27L												
	Distance ^d																						
	m	ft	m	ft	m	ft	m	ft	m	ft	m	ft											
Nose	49	160	52	170	174	572	157	516	152	500	39	129	158	519	44	145	41	133	181	593	45	146	
Wingtip	50	164	53	174	--	--	--	--	--	--	--	--	--	--	--	--	--	--	--	--	--	--	--
Cabin roof	--	--	--	--	174	572	157	516	152	500	39	129	158	519	45	148	40	131	181	593	45	149	

^bRelative to propeller plane axis.

^cDegrees left (L) and right (R) of center.

^dMicrophone to propeller plane axis.

TABLE V.—Continued.
(b) Concluded.

Learjet microphone	Position																					
	Run																					
	6B	6C	6D	6E	6F	7B	7C	7D	7E	7F	7G											
	269	268	267	266	265	263	262	261	260	264	259	258										
	Sideline angle, ^b deg																					
Nose	60	73	89	103	118	56	72	89	102	103	119	135										
Wingtip	63	77	95	110	126	60	78	96	112	111	128	144										
Cabin roof										
	Azimuthal angle, ^c deg																					
Nose	60L	60L	60L	60L	60L	90L	90L	90L	90L	90L	90L	90L										
Wingtip	60L	60L	60L	60L	60L	90L	90L	90L	90L	90L	90L	90L										
Cabin roof										
	Distance ^d																					
	m	ft	m	ft	m	ft	m	ft	m	ft	m	ft	m	ft								
Nose	75	246	72	235	71	233	69	226	63	208	62	203	53	175	50	163	58	191	53	174	53	173
Wingtip	67	220	65	212	66	217	66	216	62	205	54	176	46	152	47	153	55	182	52	172	55	179
Cabin roof

^bRelative to propeller plane axis.

^cDegrees left (L) and right (R) of center.

^dMicrophone to propeller plane axis.

TABLE V.—Continued.

(c) Case 3

Learjet microphone	Position																						
	1B	1C	1D	1E	1F	1G	2B	2C															
	176	175	174	173	172	171	186	185	322														
	Run																						
	Sideline angle, ^b deg																						
Nose	58	74	88	102	120	133	60	75	72														
Wingtip	--	--	--	---	---	---	--	--	--														
Cabin roof	59	74	89	103	121	134	60	75	77														
	Azimuthal angle, ^c deg																						
Nose	0	1R	1R	1R	1R	1R	29R	30R	37R														
Wingtip	-	--	--	--	--	--	---	---	---														
Cabin roof	0	1R	1R	1R	8R	1R	29R	30R	37R														
	Distance ^d																						
	m	ft	m	ft	m	ft	m	ft	m	ft													
Nose	186	610	170	557	152	500	149	488	164	539	32	104	190	624	50	165	237	779	220	723	30	99	
Wingtip	---	---	---	---	---	---	---	---	---	---	--	---	---	---	---	---	---	---	---	---	---	---	---
Cabin roof	184	604	170	557	152	500	149	490	165	544	33	108	193	634	53	174	237	779	220	723	30	97	

^bRelative to propeller plane axis.

^cDegrees left (L) and right (R) of center.

^dMicrophone to propeller plane axis.

TABLE V.—Continued.
(c) Continued.

Learjet microphone	Position											
	Run						Run					
	2D	2E	2F	3B	3C	3D	3E	3F	3D	3E	3F	3F
	184	321	183	320	182	319	252	251	250	249	248	248
	Sideline angle, ^b deg											
Nose	89	87	104	99	119	116	60	76	88	101	116	116
Wingtip	--	--	---	--	---	---	63	79	93	108	122	122
Cabin roof	89	92	105	103	120	121	--	--	--	---	---	---
	Azimuthal angle, ^c deg											
Nose	30R	37R	31R	35R	31R	38R	60R	60R	60R	60R	60R	60R
Wingtip	---	---	---	---	---	---	60R	60R	60R	60R	60R	60R
Cabin roof	30R	37R	31R	35R	31R	38R	---	---	---	---	---	---
	Distance ^d											
	m	ft	m	ft	m	ft	m	ft	m	ft	m	ft
Nose	218	715	29	95	214	703	39	127	238	780	29	94
Wingtip	---	---	---	---	---	---	--	---	---	---	--	--
Cabin roof	218	715	29	95	215	706	39	129	240	788	30	99

^bRelative to propeller plane axis.

^cDegrees left (L) and right (R) of center.

^dMicrophone to propeller plane axis.

TABLE V.—Continued.
(c) Continued.

Learjet microphone	Position																					
	Run													5D								
	4B	4C	4D	4E	4F	4G	5B	5C	5D	5E	5F	5G	5H	5I								
246	245	244	243	242	241	181	180	338	179	337												
Sideline angle, ^b deg																						
Nose	59	72	86	100	115	129	58	74	73	89	89	89	89	89								
Wingtip	61	76	92	108	124	138	--	--	--	--	--	--	--	--								
Cabin roof	--	--	--	--	--	--	59	75	76	90	90	90	90	93								
Azimuthal angle, ^c deg																						
Nose	90R	90R	90R	90R	90R	90R	26L	27L	26L	29L	25L	29L	29L	25L								
Wingtip	90R	90R	90R	90R	90R	90R	---	---	---	---	---	---	---	---								
Cabin roof	---	---	---	---	---	---	26L	27L	26L	29L	25L	29L	29L	25L								
Distance ^d																						
	m	ft	m	ft	m	ft	m	ft	m	ft	m	ft	m	ft								
Nose	103	338	81	266	71	234	64	209	55	179	52	171	166	545	39	128	169	555	40	132		
Wingtip	95	313	74	244	66	217	61	199	54	177	54	176	---	---	--	---	---	---	--	---		
Cabin roof	--	---	--	---	--	---	--	---	--	---	--	---	174	570	165	542	41	136	169	555	40	132

^bRelative to propeller plane axis.

^cDegrees left (L) and right (R) of center.

^dMicrophone to propeller plane axis.

TABLE V.—Continued.
(c) Continued.

Learjet microphone	Position																										
	5E			5F			6B			6C			6D			6E			6F			7B			7C		
Run																											
Sideline angle, ^b deg																											
Azimuthal angle, ^c deg																											
Distance ^d																											
	m	ft	m	ft	m	ft	m	ft	m	ft	m	ft	m	ft	m	ft	m	ft	m	ft	m	ft	m	ft	m	ft	
Nose	103	336	177	335	239	238	237	236	235	234	233	233	233	233	234	235	236	237	238	239	240	241	242	243	244	245	246
Wingtip	---	---	---	---	---	---	---	---	---	---	---	---	---	---	---	---	---	---	---	---	---	---	---	---	---	---	---
Cabin roof	104	107	120	121	---	---	---	---	---	---	---	---	---	---	---	---	---	---	---	---	---	---	---	---	---	---	---
Nose	31L	26L	29L	25L	60L	60L	60L	60L	60L	60L	60L	60L	60L	60L	60L	60L	60L	60L	60L	60L	60L	60L	60L	60L	60L	60L	90L
Wingtip	---	---	---	---	---	---	---	---	---	---	---	---	---	---	---	---	---	---	---	---	---	---	---	---	---	---	---
Cabin roof	31L	26L	29L	25L	---	---	---	---	---	---	---	---	---	---	---	---	---	---	---	---	---	---	---	---	---	---	---
Nose	168	550	40	130	183	599	34	113	79	260	68	222	55	179	48	157	45	146	48	158	49	161	49	158	49	161	
Wingtip	---	---	---	---	---	---	---	---	---	---	---	---	---	---	---	---	---	---	---	---	---	---	---	---	---	---	---
Cabin roof	168	552	41	133	184	605	36	118	71	233	61	199	50	163	45	147	45	145	40	131	42	138	42	131	42	138	

^bRelative to propeller plane axis.

^cDegrees left (L) and right (R) of center.

^dMicrophone to propeller plane axis.

TABLE V.—Continued.
(c) Concluded.

Learjet microphone	Position									
	7D	7E	7F	7G	7H					
	Run									
	232	231	240	230	229					
	Sideline angle, ^a deg									
Nose	88	101	102	116	135					
Wingtip	97	113	113	128	146					
Cabin roof	--	---	---	---	---					
	Azimuthal angle, ^b deg									
Nose	90L	90L	90L	90L	90L					
Wingtip	90L	90L	90L	90L	90L					
Cabin roof	---	---	---	---	---					
	Distance ^c									
	m	ft	m	ft	m	ft	m	ft	m	ft
Nose	48	158	44	144	45	148	40	131	42	139
Wingtip	43	142	41	134	42	139	39	129	45	146
Cabin roof	--	---	--	---	--	---	--	---	--	---

^bRelative to propeller plane axis.

^cDegrees left (L) and right (R) of center.

^dMicrophone to propeller plane axis.

TABLE V.—Continued.
(d) Case 4

Learjet microphone	Position																	
	Run					5C												
	1B	1C	1D	1E	1F	1G	1H	1I	1J	1K								
	164	163	162	161	160	314	159	313		318								
	Sideline angle, ^b deg																	
Nose	57	73	88	103	119	116	133	134	74									
Wingtip	--	--	--	---	---	---	---	---	--	--								
Cabin roof	57	74	89	104	119	120	134	137	78									
	Azimuthal angle, ^c deg																	
Nose	0	0	1R	2R	1L	1L	2R	1R	29L									
Wingtip	.	.	--	--	--	--	--	--	---									
Cabin roof	0	0	1R	2R	1L	1L	2R	1R	29L									
	Distance ^d																	
	m	ft	m	ft	m	ft	m	ft	m	ft								
Nose	211	692	173	567	163	536	182	596	198	649	33	107	237	776	45	149	40	131
Wingtip	--	---	--	---	---	---	---	---	--	---	--	---	---	--	---	--	---	---
Cabin roof	211	692	172	564	163	536	183	599	198	649	34	111	240	789	48	157	39	128

^bRelative to propeller plane axis.

^cDegrees left (L) and right (R) of center.

^dMicrophone to propeller plane axis.

TABLE V.—Continued.
(d) Continued.

Leafjet microphone	Position									
	5D	5E	5F	6C	6D	6E	6F	7B	7C	
	Run									
	317	316	315	228	227	226	225	223	222	
	Sideline angle, ^b deg									
Nose	90	105	119	73	90	103	119	56	71	
Wingtip	--	--	--	79	98	112	129	59	77	
Cabin roof	93	109	122	--	--	--	--	--	--	
	Azimuthal angle, ^c deg									
Nose	29L	28L	26L	60L	60L	60L	60L	90L	90L	
Wingtip	--	--	--	60L	60L	60L	60L	90L	90L	
Cabin roof	29L	28L	26L	--	--	--	--	--	--	
	Distance ^d									
	m	ft	m	ft	m	ft	m	ft	m	ft
Nose	49	160	41	136	44	144	56	185	52	171
Wingtip	--	--	--	--	50	163	48	156	48	158
Cabin roof	49	160	42	139	45	148	--	--	--	--

^bRelative to propeller plane axis.

^cDegrees left (L) and right (R) of center.

^dMicrophone to propeller plane axis.

TABLE V.—Continued.
(d) Concluded.

Learjet microphone	Position									
	7D		7E		7F		7G			
	Run									
	221	220	224	219	218					
	Sideline angle, ^b deg									
Nose	87	104	110	118	135					
Wingtip	97	115	104	128	145					
Cabin roof	--	---	---	---	---					
	Azimuthal angle, ^c deg									
Nose	90L	90L	90L	90L	90L	90L	90L			
Wingtip	90L	90L	90L	90L	90L	90L	90L			
Cabin roof	---	---	---	---	---	---	---			
	Distance ^d									
	m	ft	m	ft	m	ft	m	ft		
Nose	47	155	46	150	48	159	47	155	48	158
Wingtip	42	139	43	142	41	136	47	153	50	165
Cabin roof	--	---	--	---	--	---	--	---	--	---

^bRelative to propeller plane axis.

^cDegrees left (L) and right (R) of center.

^dMicrophone to propeller plane axis.

TABLE V.—Continued.

(c) Case 6

Learjet microphone	Position													
	Run													7G
	1D	1E	1F	7B	7C	7D	7E	7F	7G	7H	7I	7J	7K	
	134	133	132	215	214	213	212	211	210					210
	Sideline angle, ^b deg													
Nose	89	103	119	54	72	87	103	119	135					135
Wingtip	--	---	---	57	77	94	112	128	145					145
Cabin roof	90	104	119	--	--	--	---	---	---					---
	Azimuthal angle, ^c deg													
Nose	0	1R	1R	90L	90L	90L	90L	90L	90L					90L
Wingtip	-	--	--	90L	90L	90L	90L	90L	90L					90L
Cabin roof	0	1R	1R	---	---	---	---	---	---					---
	Distance ^d													
	m	ft	m	ft	m	ft	m	ft	m	ft	m	ft	m	ft
Nose	208	682	199	654	202	664	67	221	76	250	59	194	53	173
Wingtip	---	---	---	---	---	---	59	194	69	227	54	178	50	164
Cabin roof	208	682	200	656	202	664	--	---	--	---	--	---	--	---
	m	ft	m	ft	m	ft	m	ft	m	ft	m	ft	m	ft
Nose	208	682	199	654	202	664	67	221	76	250	59	194	53	173
Wingtip	---	---	---	---	---	---	59	194	69	227	54	178	50	164
Cabin roof	208	682	200	656	202	664	--	---	--	---	--	---	--	---

^bRelative to propeller plane axis.

^cDegrees left (L) and right (R) of center.

^dMicrophone to propeller plane axis.

TABLE V.—Continued.
(f) Case 7

Learjet microphone	Position																	
	1B	1C	1D	1E	1F	1G	5C											
	Run																	
	131	130	129	128	127	299	126	298	303									
	Sideline angle, ^b deg																	
Nose	60	73	87	103	116	121	137	137	74	74								
Wingtip	--	--	--	---	---	---	---	---	--	--								
Cabin roof	61	74	88	103	117	123	137	139	77	77								
	Azimuthal angle, ^c deg																	
Nose	1L	0	1L	0	0	4R	1L	3R	33L	33L								
Wingtip	--	-	--	-	-	--	--	--	---	---								
Cabin roof	1L	0	1L	0	0	4R	1L	3R	33L	33L								
	Distance ^d																	
	m	ft	m	ft	m	ft	m	ft	m	ft								
Nose	224	735	194	636	190	623	188	617	201	661	48	159	285	934	44	143	47	154
Wingtip	---	---	---	---	---	---	---	---	---	---	---	---	---	---	---	---	---	---
Cabin roof	222	728	193	633	190	623	188	617	203	667	49	162	285	934	45	149	46	151

^bRelative to propeller plane axis.

^cDegrees left (L) and right (R) of center.

^dMicrophone to propeller plane axis.

TABLE V.—Continued.

(f) Concluded.

Learjet microphone	Position																	
	5D	5E	5F	7B	7C	7D	7E	7F	7G	Run								
	302	301	300	198	197	196	195	194	193									
	Sideline angle, ^b deg																	
Nose	85	102	116	57	71	88	103	119	134									
Wingtip	--	---	---	60	75	94	111	128	142									
Cabin roof	89	106	119	--	--	--	---	---	---									
	Azimuthal angle, ^c deg																	
Nose	33L	34L	31L	90L	90L	90L	90L	90L	90L									
Wingtip	---	---	---	90L	90L	90L	90L	90L	90L									
Cabin roof	33L	34L	31L	---	---	---	---	---	---									
	Distance ^d																	
	m	ft	m	ft	m	ft	m	ft	m	ft	m	ft	m	ft				
Nose	33	107	38	124	40	130	83	271	67	220	71	232	60	198	58	190	66	218
Wingtip	--	---	--	---	--	---	74	244	60	197	66	215	58	189	57	188	68	223
Cabin roof	33	107	38	126	41	134	--	---	--	---	--	---	--	---	--	---	---	---

^bRelative to propeller plane axis.

^cDegrees left (L) and right (R) of center.

^dMicrophone to propeller plane axis.

TABLE V.—Continued.
(g) Case 8

Learjet microphone	Position															
	1B	1C	1D	1E	1F	1G	5C									
	Run															
	125	124	123	122	121	120	305	120	304	309						
Sideline angle, ^b deg																
Nose	59	74	88	102	120	120	120	137	135	70						
Wingtip	--	--	--	---	---	---	---	---	---	--						
Cabin roof	60	75	89	103	122	122	122	138	138	74						
Azimuthal angle, ^c deg																
Nose	2R	0	0	2L	0	0	3R	1L	2R	30L						
Wingtip	--	-	--	--	-	-	--	--	--	---						
Cabin roof	2R	0	0	2L	0	0	3R	1L	2R	30L						
Distance ^d																
	m	ft	m	ft	m	ft	m	ft	m	ft	m	ft				
Nose	228	748	144	474	141	462	144	472	162	533	201	661	52	172	42	138
Wingtip	---	---	---	---	---	---	---	---	---	---	---	---	---	---	---	---
Cabin roof	226	740	144	472	141	461	144	473	165	544	205	674	55	181	41	135

^bRelative to propeller plane axis.

^cDegrees left (L) and right (R) of center.

^dMicrophone to propeller plane axis.

TABLE V.—Continued.
(g) Concluded.

Learjet microphone	Position																	
	Run																	
	5D	5E	5F	7B	7C	7D	7E	7F	7G									
	308	307	306	192	191	190	189	188	187									
	Sideline angle, ^b deg																	
Nose	85	99	115	58	73	86	104	118	135									
Wingtip	--	---	---	60	78	95	113	127	143									
Cabin roof	89	104	118	--	--	--	---	---	---									
	Azimuthal angle, ^c deg																	
Nose	32L	32L	34L	90L	90L	90L	90L	90L	90L									
Wingtip	---	---	---	90L	90L	90L	90L	90L	90L									
Cabin roof	32L	32L	34L	---	---	---	---	---	---									
	Distance ^d																	
	m	ft	m	ft	m	ft	m	ft	m	ft	m	ft	m	ft				
Nose	36	119	28	92	36	118	98	321	68	222	49	161	51	166	53	174	61	200
Wingtip	--	---	--	--	--	---	90	295	61	199	44	144	48	157	52	171	63	206
Cabin roof	36	119	29	94	37	121	--	---	--	---	--	---	--	---	--	---	--	---

^bRelative to propeller plane axis.
^cDegrees left (L) and right (R) of center.
^dMicrophone to propeller plane axis.

TABLE VI.—LEARJET BACKGROUND

NOISE LEVELS

[4-Hz bandwidth spectra.]

(a) Cases 1, 7, and 8: 10 688-m (35 000-ft) altitude,
Mach 0.70, background noise run 216

Learjet microphone	Sound pressure level, dB			
	Tone order ^a			
	BPF	2BPF	3BPF	4BPF
M-1	98.5	97.5	96.5	96.5
M-2	97.5	96.5	94.0	92.0
M-3	103.0	101.0	102.0	101.0
M-4	99.0	98.0	96.7	97.2
M-5	99.3	98.3	100.0	99.5
M-6	97.5	97.0	98.5	96.8
M-7	96.5	94.5	94.5	94.5
M-8	100.0	100.0	100.0	98.0
M-9	102.0	100.0	101.0	99.5
M-10	101.0	100.0	99.5	99.0
M-11	109.0	108.0	108.0	106.0
M-12	110.0	109.0	108.5	107.0

(b) Case 2: 6096-m (20 000-ft) altitude, Mach 0.70,
background noise run 253

Learjet microphone	Sound pressure level, dB			
	Tone order ^a			
	BPF	2BPF	3BPF	4BPF
M-1	114.0	111.5	108.5	106.5
M-2	105.0	101.5	101.5	100.0
M-3	111.5	109.0	106.5	107.5
M-4	103.5	102.0	103.5	104.5
M-5	111.5	106.0	104.5	104.5
M-6	105.0	103.0	103.0	101.5
M-7	103.0	100.5	100.5	103.0
M-8	100.0	101.0	102.0	103.0
M-9	102.5	100.0	102.0	103.0
M-10	108.0	107.0	105.0	105.0
M-11	112.5	114.0	114.0	111.0
M-12	114.5	113.5	111.5	111.5

^aBlade passage frequency (BPF).

TABLE VI.—Continued.

(c) Case 3: 6096-m (20 000-ft) altitude, Mach 0.50,
background noise run 247

Learjet microphone	Sound pressure level, dB			
	Tone order ^a			
	BPF	2BPF	3BPF	4BPF
M-1	98.0	97.5	95.5	96.5
M-2	93.0	94.0	94.5	94.0
M-3	100.5	98.5	99.0	99.0
M-4	99.0	98.0	100.0	99.5
M-5	100.5	99.0	99.5	99.0
M-6	98.0	98.5	97.5	98.5
M-7	93.5	94.0	94.0	95.5
M-8	95.5	98.0	97.5	98.0
M-9	96.8	97.5	99.0	98.0
M-10	99.0	100.5	99.0	98.5
M-11	109.5	109.0	108.0	107.0
M-12	110.5	107.0	106.5	106.0

(d) Case 4: 4267-m (14 000-ft) altitude, Mach 0.59,
background noise runs 159 and 218

Learjet microphone	Sound pressure level, dB			
	Tone order ^a			
	BPF	2BPF	3BPF	4BPF
M-1	(b)	(b)	(b)	(b)
M-2	(b)	(b)	(b)	(b)
M-3	101.0	101.0	101.0	100.5
M-4	101.0	101.5	101.5	102.0
M-5	102.0	100.0	102.5	101.0
M-6	100.0	100.5	99.5	99.5
M-7	(b)	(b)	(b)	(b)
M-8	(b)	(b)	(b)	(b)
M-9	98.5	97.5	97.0	99.0
M-10	104.0	103.0	103.0	102.5
M-11	108.0	106.5	106.0	105.0
M-12	113.0	111.5	111.0	108.5

^aBlade passage frequency (BPF).^bNot applicable.

TABLE VI.—Concluded.

(e) Case 6: 10 688-m (35 000-ft) altitude,
Mach 0.77, background noise run 217

Learjet microphone	Sound pressure level, dB			
	Tone order ^a			
	BPF	2BPF	3BPF	4BPF
M-1	104.5	100.0	99.0	97.5
M-2	99.0	97.0	96.0	95.5
M-3	105.5	104.0	103.5	101.5
M-4	98.5	100.0	98.0	97.5
M-5	99.5	99.0	100.0	99.5
M-6	96.0	97.5	98.0	99.0
M-7	99.0	97.0	94.5	96.0
M-8	101.0	100.5	100.5	101.5
M-9	102.0	101.0	102.0	102.0
M-10	100.0	102.0	98.0	98.5
M-11	108.0	109.5	107.5	106.5
M-12	111.0	110.0	108.5	110.5

^aBlade passage frequency (BPF).

TABLE VII.—AS-MEASURED ACOUSTIC DATA^a

(a) Case 1

Microphone	Sound pressure level, dB							
	Position							
	1B							
	Run							
	106				142			
	Tone order ^b							
	BPF	2BPF	3BPF	4BPF	BPF	2BPF	3BPF	4BPF
	Gulfstream fuselage							
M-123								
M-193	122	115.5			122	114.5		
M-243	130.5	126	120	117	133	126	122	120.5
M-273	136.5	135	132	128.5	139	136	133	130
M-303	138.5	135.5	132	127.5	141	136.5	133	129
M-323	140.5	138	130	115	143	138.5	130.5	118.5
M-353	139.5	133.5	126.5	119	141.5	133.5	128	120
M-403	130.5	121	113		128	117.5	115	109
M-463	134	121	117.5	115	136.5	123.5	120.5	119
Gulfstream boom								
ABM1	117	111.5	106.5	105	118.5	114	107.5	107.5
ABM2	139	137	131	124.5	141	138	133	127
ABM4	124.5	128.5	120	119.5	130.5	131.5	125	124
ABM5	124	120.5	117	115.5	126	119	119	116.5
Learjet								
M-1								
M-2								
M-3								
M-4								
M-5								
M-6								
M-7								
M-8								
M-9								
M-10								
M-11								
M-12								

^aBlank spaces indicate that no data were available.

^bBlade passage frequency (BPF).

TABLE VII.—Continued.

(a) Continued.

Microphone	Sound pressure level, dB											
	Position											
	1C											
	Run											
	105				109				141			
	Tone order ^b											
	BPF	2BPF	3BPF	4BPF	BPF	2BPF	3BPF	4BPF	BPF	2BPF	3BPF	4BPF
	Gulfstream fuselage											
M-123												
M-193	122.5	115.5			122.5	115.5			121			
M-243	131	126	120	119	131	125.5	120.5	119.5	133	126	122	120.5
M-273	136.5	135	131.5	129	136	135	130.5	129	139	136	132.5	130
M-303	139	136	132.5	128	138.5	136	131.5	128.5	141	136.5	133	129
M-323	141	138	130	118	140	137.5	129.5	120	142.5	138	130.5	117.5
M-353	140	133	127.5	119.5	139	133	127	119.5	141.5	133	128	120
M-403	129	117.5	114	107.5	128	116.5	116		128.5	117	114.5	107.5
M-463	134	121.5	120	117	134	122.5	119.5	117.5	136	123.5	120.5	117.5
Gulfstream boom												
ABM1	116.5	111.5	106.5	106	115.5	113.5	105.5	106	118.5	114	107.5	107
ABM2	139	137	130.5	123	139	137.5	131	124.5	141	138	133.5	127
ABM4	126.5	130	122	121.5	128	132	123.5	123	130.5	131.5	124.5	123.5
ABM5	123	120	118	115.5	122.5	119	118.5	116	126.5	119	119	117
Learjet												
M-1												
M-2												
M-3												
M-4												
M-5	102								103			
M-6	100.5	99.5							100			
M-7												
M-8												
M-9												
M-10												
M-11												
M-12												

^bBlade passage frequency (BPF).

TABLE VII.—Continued.

(a) Continued.

Microphone	Sound pressure level, dB											
	Position											
	1D											
	Run											
	104				108				140			
	Tone order ^b											
	BPF	2BPF	3BPF	4BPF	BPF	2BPF	3BPF	4BPF	BPF	2BPF	3BPF	4BPF
	Gulfstream fuselage											
M-123												
M-193	121.5	116			121.5				123.5			
M-243	130.5	126	120	118	130	124.5	120	117	132.5	126	121.5	120
M-273	136	135	131	129	136	134.5	130.5	127.5	139	136	132.5	130
M-303	138	135.5	131.5	128	138	135.5	131.5	126.5	141	136.5	133	129
M-323	140	138	130	115.5	140	137	129	116	142.5	138.5	130.5	116.5
M-353	139	133	125	119.5	139	132.5	126.5	117.5	141.5	133.5	128	120
M-403	131	121	111.5	107	128.5	118	112.5		130	117.5	114.5	107.5
M-463	133.5	121.5	117.5	112.5	133	121	117.5	114.5	136.5	123.5	120	116
Gulfstream boom												
ABM1	117	112.5	107.5	106.5	116	112.5	104.5	104.5	118.5	114	107	106.5
ABM2	139.5	138	131.5	125.5	139	137.5	131	123	141.5	138	133	127
ABM4	126	128.5	121.5	119.5	128	132.5	125	124	130	131.5	123.5	122.5
ABM5	124	121.5	116	115.5	124.5	119	119	114.5	127	118.5	118	116.5
Learjet												
M-1												
M-2												
M-3												
M-4												
M-5	105								103			
M-6	105.5	100.5			100				100.5			
M-7												
M-8												
M-9												
M-10												
M-11	109											
M-12	112.5											

^bBlade passage frequency (BPF).

TABLE VII.—Continued.^a

(a) Continued.

Microphone	Sound pressure level, dB											
	Position											
	1E											
	Run											
	103				107				139			
	Tone order ^b											
	BPF	2BPF	3BPF	4BPF	BPF	2BPF	3BPF	4BPF	BPF	2BPF	3BPF	4BPF
	Gulfstream fuselage											
M-123												
M-193	122.5	116.5			122				124	117		
M-243	131	125.5	121	119	130.5	125.5	120	118.5	133	126	122	120.5
M-273	136.5	135	132	128.5	136.5	134.5	130.5	128	139	136	132.5	130
M-303	138.5	136	132.5	128	138.5	136	131.5	127.5	141	136.5	133	129
M-323	140.5	138	130	118	140.5	137	129.5	118	142.5	139	130.5	117.5
M-353	140	133	127.5	119	139.5	133	127	118.5	141.5	133.5	127.5	120
M-403	130.5	118	113		129.5	117.5	113.5		129	117.5	114	107
M-463	133.5	121	119	113	133.5	120	119.5	115	136.5	124	120	117
Gulfstream boom												
ABM1	116.7	112	117.5	116.5	116.5	111.5	105.5	104.5	118.5	114	107	106.5
ABM2	139.5	137.5	131.5	123.5	139.5	137	130.5	123	141.5	138	133	127
ABM4	127	130.5	122.5	121.5	127	130.5	122	121.5	130.5	131.5	124	123
ABM5	123.5	120	118.5	116	124	119.5	118	115	126.5	119	118	116.5
Learjet												
M-1												
M-2												
M-3												
M-4												
M-5	110	104.5	101.5		102.5				108.5	104		
M-6	110.5	104	101	100	102				109.5	103.5	99.5	100
M-7												
M-8												
M-9												
M-10												
M-11	113	108							113			
M-12	115								113.5			

^bBlade passage frequency (BPF).

TABLE VII.—Continued.

(a) Continued.

Microphone	Sound pressure level, dB											
	Position											
	1F											
	Run											
	102				138				289			
	Tone order ^b											
	BPF	2BPF	3BPF	4BPF	BPF	2BPF	3BPF	4BPF	BPF	2BPF	3BPF	4BPF
	Gulfstream fuselage											
M-123												
M-193	122				124.5	117			(c)			
M-243	130.5	125.5	120.5	119	133	126.5	122	121	131	124	119.5	117.5
M-273	136.5	135	131.5	128.5	139	136	133	130	137	134	131.5	129
M-303	138.5	136	132	128	141	136.5	133	129	139	134.5	132.5	129
M-323	140.5	138	130	117	143	138	130.5	118.5	140.5	136.5	131	115.5
M-353	139.5	133	127	119	142	133.5	128.5	120	139.5	131	124.5	118.5
M-403	129.5	119.5	112.5		128	117.5	115.5	110.5	132.5	119.5		110
M-463	133.5	121.5	119.5	115.5	136.5	124.5	121.5	119	133.5	118.5	115.5	
Gulfstream boom												
ABM1	117	111.5	107.5	105.5	118.5	114	107	107	118.5	111.5	108.5	106.5
ABM2	139.5	137.5	131	123.5	141	138	133	126.5	141	137	132.5	125.5
ABM4	126.5	130	122	120.5	130.5	131.5	125	124	129.5	130	125	120
ABM5	123.5	120	118.5	116	125.5	119	119	117	125.5	119	118.5	116.5
Learjet												
M-1												
M-2												
M-3												
M-4												
M-5	106.5	98			108				121	111.5		
M-6	106.5				108				121	111		
M-7												
M-8												
M-9												
M-10									112	103.5		
M-11	110				109.5				121			
M-12									121	110.5		

^bBlade passage frequency (BPF).^cFaulty data.

TABLE VII.—Continued.

(a) Continued.

Microphone	Sound pressure level, dB											
	Position											
	1G						2B					
	Run											
	101				288				119			
	Tone order ^b											
	BPF	2BPF	3BPF	4BPF	BPF	2BPF	3BPF	4BPF	BPF	2BPF	3BPF	4BPF
Gulfstream fuselage												
M-123												
M-193	123				(c)				122.5			
M-243	131.5	124	121	118.5	131.5	124.5	119.5	116.5	131	125.5	121	118.5
M-273	137	134	131.5	128.5	137	134.5	132	129	136.5	135	132	128
M-303	139	134.5	132.5	128	139.5	135	132.5	128	139	136	132.5	127.5
M-323	141	137	130	117.5	141	138	130.5	117	141	137.5	130	117.5
M-353	140	132	127.5	119.5	140.5	133	127	119.5	139.5	132.5	127.5	118
M-403	132	117	114		132.5	120.5	112		128	116	115	105.5
M-463	134	119.5	119.5	113	134	119.5	119		134.5	123.5	120	115.5
Gulfstream boom												
ABM1	117.5	111	107.5	106	118	111.5	107.5	105	116	113	106	105
ABM2	140	136.5	131.5	124	140.5	137	131.5	122	139	137.5	132.5	125
ABM4	127	128	122	119.5	127	128.5	123	117.5	128.5	131.5	123.5	122
ABM5	124.5	119.5	118.5	117	125.5	120	119	115	123	118	119	115.5
Learjet												
M-1												
M-2												
M-3												
M-4												
M-5					107.5							
M-6					107.5							
M-7												
M-8												
M-9												
M-10												
M-11												
M-12					106							

^bBlade passage frequency (BPF).^cFaulty data.

TABLE VII.—Continued.

(a) Continued.

Microphone	Sound pressure level, dB							
	Position							
	2C							
	Run							
	118				297			
	Tone order ^b							
	BPF	2BPF	3BPF	4BPF	BPF	2BPF	3BPF	4BPF
Gulfstream fuselage								
M-123								
M-193	120.5				(c)			
M-243	130	125	120	119	131.5	125.5	120.5	118.5
M-273	136.5	135.5	131.5	129	137	135	131	128
M-303	138.5	135.5	131.5	128	139	136.5	132.5	127.5
M-323	140	137.5	130	115.5	141.5	137	130	119.5
M-353	138.5	132.5	126	119	140	133	128.5	119
M-403	128.5	118.5	111	107.5	126	115	118.5	110
M-463	133.5	122	118	115	134	122	121	116
Gulfstream boom								
ABM1	117	113.5	107	105.5	116.5	110.5	104.5	103.5
ABM2	139.5	138	132.5	126	140	137.5	132	123
ABM4	127	130.5	123	120.5	128.5	132.5	126	123.5
ABM5	125	118	119	116	126	119	120	114
Learjet								
M-1					98	98.5	93.5	92
M-2					(c)			
M-3								
M-4								
M-5	101.5				108	108.5	105.5	
M-6					109	109	104.5	103
M-7	99.5				119	113	109	106
M-8					119.5	113	109.5	106.5
M-9								
M-10								
M-11					116	113		
M-12					114	111	110	

^bBlade passage frequency (BPF).^cFaulty data.

TABLE VII.—Continued.

(a) Continued.

Microphone	Sound pressure level, dB							
	Position							
	2D							
	Run							
	117				296			
	Tone order ^b							
	BPF	2BPF	3BPF	4BPF	BPF	2BPF	3BPF	4BPF
	Gulfstream fuselage							
M-123								
M-193	121				(c)			
M-243	130.5	125	120	117	131.5	124.5	120	117.5
M-273	136.5	135	131.5	127.5	137	134.5	132	129.5
M-303	138.5	135.5	132	127	139.5	134.5	132.5	129
M-323	140	137.5	130.5	112.5	141	137	132	118
M-353	138.5	132	125	117.5	139.5	132	125	119.5
M-403	127	119	110	109	133	121	111	110
M-463	133	121	117.5	114.5	134	120	117	
Gulfstream boom								
ABM1	116.5	113	106.5	104.5	118	111	108.5	106
ABM2	139.5	137.5	132.5	125.5	141	137.5	133.5	127
ABM4	128.5	130.5	124	120	128	128.5	124	119.5
ABM5	125	117	119	114.5	126	120	118.5	116.5
Learjet								
M-1					105	99.5	99	93.5
M-2	97.5				(c)			
M-3								
M-4								
M-5	102.5				115	112.5	108	105
M-6	103				116	112	110	106.5
M-7	102	99			124	115.5	110	108.5
M-8	104				124	116	110	108
M-9								
M-10								
M-11	108.5				121	118	111	
M-12					120	116.5	111.5	108

^bBlade passage frequency (BPF).^cFaulty data.

TABLE VII.—Continued.

(a) Continued.

Microphone	Sound pressure level, dB							
	Position							
	2E							
	Run							
	116				295			
	Tone order ^b							
	BPF	2BPF	3BPF	4BPF	BPF	2BPF	3BPF	4BPF
	Gulfstream fuselage							
M-123								
M-193	122	115			(c)			
M-243	130.5	126	121	118.5	131.5	124.5	120	118
M-273	136.5	135	132	128	137	134.5	132	129.5
M-303	139	135.5	132	127.5	139.5	135	133	129
M-323	140.5	138	130	115	141.5	137	131	115
M-353	139.5	133	127.5	118.5	140	131.5	126.5	119.5
M-403	128	119	111.5		132	118.5	112	
M-463	134	121	119	116	134.5	119.5	119	115
Gulfstream boom								
ABM1	116.5	113	106	104.5	118	110.5	107.5	106
ABM2	139.5	137.5	132.5	125	141	137	132.5	126
ABM4	129	131	124	121	128	129.5	123.5	119.5
ABM5	124.5	117	119.5	114.5	125	118.5	120	117.5
Learjet								
M-1					110	103.5	99	98
M-2	100.5				(c)			
M-3								
M-4								
M-5	105.5				119.5	116	103.5	105.5
M-6					121	116.5	111	110
M-7	107				123.5	115.5	108	107
M-8					124	115.5	108.5	108
M-9								
M-10								
M-11	111				124.5	120.5	110	110.5
M-12	112				123.5	119	110.5	109.5

^bBlade passage frequency (BPF).^cFaulty data.

TABLE VII.—Continued.

(a) Continued.

Microphone	Sound pressure level, dB							
	Position							
	2F							
	Run							
	115				294			
	Tone order ^b							
	BPF	2BPF	3BPF	4BPF	BPF	2BPF	3BPF	4BPF
Gulfstream fuselage								
M-123	112							
M-193	121.5				(c)			
M-243	130.5	125.5	120.5	118.5	131.5	124.5	120	118
M-273	136.5	135	131.5	128	137	134.5	132	129
M-303	138.5	135.5	132	128	139.5	135	133	129
M-323	140.5	137.5	130	115.5	141.5	137	131	115
M-353	139	133	127	119	140	131.5	126.5	119.5
M-403	131	120.5	112	107	130.5	118.5	111.5	
M-463	133.5	120.5	117.5	113.5	134	120	119	115
Gulfstream boom								
ABM1	117	112.5	107.5	105.5	117.5	110.5	107.5	106
ABM2	139.5	137.5	132	125	140.5	137.5	133	126.5
ABM4	127	130	122.5	119.5	128.5	130	124	119
ABM5	124.5	120	118.5	115.5	125	117.5	120	117
Learjet								
M-1	102.5	98.5			110	105	95	95
M-2	101				(c)			
M-3								
M-4								
M-5	106				119.5	113	106.5	106.5
M-6	107.5	100.5			121.5	114.5	107	107
M-7	106.5	99			118	109		
M-8	107.5	103			118.5	109		
M-9								
M-10								
M-11	110				121	115.5		
M-12	112				120.5	116		

^bBlade passage frequency (BPF).^cFaulty data.

TABLE VII.—Continued.

(a) Continued.

Microphone	Sound pressure level, dB												
	Position												
	5B					5C							
	Run												
	114					113				293			
	Tone order ^b												
	BPF	2BPF	3BPF	4BPF	BPF	2BPF	3BPF	4BPF	BPF	2BPF	3BPF	4BPF	
	Gulfstream fuselage												
M-123													
M-193	121	115.5			122				(c)				
M-243	130.5	125	120.5	118.5	130	124.5	120	118	130.5	124.5	120	118.5	
M-273	136.5	135	131	128.5	136	135	131.5	128	137	134.5	132	128.5	
M-303	138.5	136	132	128	138.5	135.5	132	127.5	139	135	133	128.5	
M-323	140.5	137.5	130	117.5	140	138	130	115.5	141	137	131	115.5	
M-353	139	132.5	127	119	138.5	132.5	125.5	118.5	139.5	131.5	126.5	119	
M-403	127.5	117	112		132.5	120	110.5	108.5	131	118.5	111	109	
M-463	133.5	121.5	119	116.5	134	119	115.5	112	133.5	120	117	114.5	
Gulfstream boom													
ABM1	116	112.5	106.5	105.5	116.5	113	107	106.5	117.5	112	108	106.5	
ABM2	139.5	137.5	132	124	139.5	138	132.5	126	141	138.5	133.5	127	
ABM4	128.5	131.5	124	122	127.5	130.5	123.5	121	130	131	125	120	
ABM5	123.5	118.5	119	115.5	124	119	119.5	116.5	125	117.5	120	117.5	
Learjet													
M-1													
M-2													
M-3					103				107	105	103		
M-4									106	103.5			
M-5	101.5								110.5	107.5	104	103.5	
M-6	99				100.5				110.5	107	104.5	102.5	
M-7													
M-8													
M-9					104.5				118.5	112	109	107	
M-10					103				118	111	109	107	
M-11									115	113.5	110.5		
M-12									116	113.5	107.5		

^bBlade passage frequency (BPF).^cFaulty data.

TABLE VII.—Continued.

(a) Continued.

Microphone	Sound pressure level, dB											
	Position											
	5D						5E					
	Run											
	112				292				111			
	Tone order ^b											
	BPF	2BPF	3BPF	4BPF	BPF	2BPF	3BPF	4BPF	BPF	2BPF	3BPF	4BPF
Gulfstream fuselage												
M-123												
M-193	119				(c)				121			
M-243	130	125	120	118	131	124	120	118	130	125.5	120	119
M-273	136	135	131	128	137	134.5	132.5	129.5	136	135.5	131	129
M-303	138.5	135.5	132	127	139.5	134.5	132.5	129	138.5	136	131.5	128.5
M-323	140	137.5	130	114.5	141	137	131	116	140	138	130	117.5
M-353	138.5	132	124.5	118	139.5	131.5	126	119	139	133	127	119
M-403	132	119.5	110	110	132	120	111	109.5	130.5	117.5	111	
M-463	133.5	119	116	113	134	120	117	113	134	119.5	119	114.5
Gulfstream boom												
ABM1	116.5	113	107	105.5	118	111.5	109	106.5	116	112.5	106.5	106
ABM2	139.5	138	132.5	126	141	137.5	133	126	139.5	138	132	125.5
ABM4	127.5	130	123.5	120.5	129	130	124.5	119.5	127.5	131	123	122
ABM5	124	119.5	118.5	115.5	125	119	120	117.5	122.5	119.5	118	116.5
Learjet												
M-1												
M-2												
M-3					111	108.5	107	104				
M-4	101.5				110.5	108	105.5	101.5	102.5			
M-5	104.5	100.5			116.5	112	112	109	108.5	103		
M-6	104				116.5	111	111	109	108.5	102	100	
M-7												
M-8												
M-9	105	102.5			123.5	118	114	110.5	108.5			
M-10	105.5	103			123	118	113.5	110	108.5	102.5		
M-11	109				125	118.5	116	112	110.5	107.5		
M-12					126	118	113	111				

^bBlade passage frequency (BPF).^cFaulty data.

TABLE VII.—Continued.

(a) Continued.

Microphone	Sound pressure level, dB											
	Position											
	5E						5F					
	Run											
	143				291				110			
	Tone order ^b											
	BPF	2BPF	3BPF	4BPF	BPF	2BPF	3BPF	4BPF	BPF	2BPF	3BPF	4BPF
	Gulfstream fuselage											
M-123												
M-193	124.5	116			(c)				122			
M-243	133	126	122	120	131	124.5	120	118.5	130.5	125	120	118
M-273	139	136	132.5	130	137	134.5	132	129	135.5	135	130.5	128
M-303	141	136.5	133	129	139.5	135	133	128.5	139	135.5	131	127.5
M-323	143	138.5	130.5	117.5	141	137	131	116.5	140	137.5	129.5	117.5
M-353	141.5	133.5	128	120	140	131.5	126.5	119.5	139	133	127	118.5
M-403	129	117.5	114.5	108	132.5	119.5	112		128	117.5	115	
M-463	136.5	124	120.5	117.5	133.5	119.5	117		134.5	122	119.5	115.5
Gulfstream boom												
ABM1	118.5	114	106.5	106.5	118	111	108	107	116	112	105.5	105
ABM2	141.5	138	133	127	141	137.5	132.5	126	139	137.5	131	125
ABM4	130	131.5	123.5	122.5	129.5	130	124.5	119.5	126.5	130.5	122	121
ABM5	126.5	119	118	116.5	125.5	118	120	117.5	123	119	117.5	115.5
Learjet												
M-1												
M-2												
M-3					115	113	107.5	106				
M-4					115	112.5	105.5	104	102.5			
M-5	102.5				121.5	119	114	111.5	109			
M-6	101.5	101			121	119	113.5	110	107			
M-7												
M-8												
M-9					125	116.5	107.5	107	106.5			
M-10					125	117	108	107	107			
M-11					125.5	120.5	112.5	112.5	111.5			
M-12					126	122	112.5	112.5				

^bBlade passage frequency (BPF).^cFaulty data.

TABLE VII.—Continued.

(a) Continued.

Microphone	Sound pressure level, dB											
	Position											
	5F				6B				6C			
	Run											
	290				209				208			
	Tone order ^b											
	BPF	2BPF	3BPF	4BPF	BPF	2BPF	3BPF	4BPF	BPF	2BPF	3BPF	4BPF
Gulfstream fuselage												
M-123												
M-193	(c)				123	117.5			122.5			
M-243	131.5	123.5	119.5	117	132	126	122.5	119	131	126	121.5	119
M-273	137	134	131	128	137.5	135.5	133	129	137.5	135.5	132.5	128.5
M-303	139.5	134.5	132	127.5	139.5	137	133	127.5	139.5	135.5	133	127
M-323	141	136.5	130	115	142	137.5	130.5	119	141	138	130	115
M-353	140	131	126	118	140.5	133	129.5	118	140	133	128	119
M-403	131.5	116.5	111		129	116.5	119	111	129	119.5	113	
M-463	134	119	117.5		135.5	127	121	117	135	122.5	120	116
Gulfstream boom												
ABM1	117.5	110.5	107	105	117	112.5	105	104.5	117.5	113	108	106
ABM2	141	137	132	124.5	139.5	137	132.5	124	140	137.5	133	125
ABM4	130	131	124.5	119.5	128.5	131.5	127	124.5	126.5	130	123	120
ABM5	125.5	117.5	120	116	124	118	120	114	125	120	118.5	115.5
Learjet												
M-1												
M-2												
M-3	120	111	103									
M-4	119.5	110	103.5	101					99			
M-5	125.5	117	108.5	105.5					101.5			
M-6	124	114.5	107	103					100			
M-7												
M-8												
M-9	118.5								105.5			
M-10	118.5								105			
M-11	123.5	112										
M-12	124.5	113										

^bBlade passage frequency (BPF).^cFaulty data.

TABLE VII.—Continued.

(a) Continued.

Microphone	Sound pressure level, dB											
	Position											
	6D				6E				6F			
	Run											
	207				206				205			
	Tone order ^b											
	BPF	2BPF	3BPF	4BPF	BPF	2BPF	3BPF	4BPF	BPF	2BPF	3BPF	4BPF
Gulfstream fuselage												
M-123												
M-193	123				123.5				123.5			
M-243	131.5	125.5	122	120	131.5	125.5	122.5	119.5	131.5	125.5	122	119
M-273	137.5	135	132.5	129	137.5	135	132.5	129	137.5	135	132.5	129
M-303	139.5	136	133.5	128	139.5	136	133.5	128	139.5	136	133	128
M-323	142	137.5	130	118	142	137.5	130.5	118	142	137.5	130	118
M-353	140.5	133	129	119.5	141	133	129	119	140.5	133	129	118.5
M-403	128	115	117.5	108	128.5	116	118	108.5	129	116.5	118.5	109
M-463	135.5	125	122	118.5	135.5	125.5	122	117	135.5	126	121	116.5
Gulfstream boom												
ABM1	116.5	113.5	106	105	117	113	106.5	105.5	116.5	113.5	106	105
ABM2	139.5	137	133	124.5	139.5	137	133	124.5	139.5	137	133	124.5
ABM4	129	131.5	125	123	128.5	131	125	123.5	129	131.5	125	123
ABM5	124.5	118	119	114	124.5	118.5	118.5	114.5	124	117.5	120	113.5
Learjet												
M-1												
M-2												
M-3	108.5	105			113	106.5			110.5	107		
M-4	107.5	103			112	106	102		110	105.5	102	
M-5	110	105	102		116	109.5	103.5		113	109	103	
M-6	108.5	104	100		114	105.5	101	100	111.5	105	100	
M-7												
M-8												
M-9	113	107.5	104.5	104	116.5	110	105		114	105.5		
M-10	113	107	104.5	102.5	116.5	110	102.5		114	105.5	101	
M-11	114.5	110.5			118.5	111			114			
M-12	116				119	112			113.5			

^bBlade passage frequency (BPF).

TABLE VII.—Continued.

(a) Continued.

Microphone	Sound pressure level, dB											
	Position											
	7B				7C				7D			
	Run											
	204				203				202			
	Tone order ^b											
	BPF	2BPF	3BPF	4BPF	BPF	2BPF	3BPF	4BPF	BPF	2BPF	3BPF	4BPF
Gulfstream fuselage												
M-123					113							
M-193	123.5				122				121.5			
M-243	133	126	121.5	118.5	132	126	120.5	118.5	131.5	125	120	118
M-273	138	135.5	132	128.5	137.5	135.5	132	128.5	137.5	135	131	128.5
M-303	140.5	136.5	132.5	127.5	140	136	132	127.5	139.5	135.5	131	127.5
M-323	142	137	130.5	119	142	138	130	114.5	141.5	137.5	129.5	115
M-353	141	133.5	129	118	140.5	133	126	118	140	132.5	125.5	118.5
M-403	128.5	117	119.5	114	130	120	111		129	119.5	110.5	
M-463	136.5	127.5	120	119	135	122.5	118	117	134.5	121.5	117.5	116.5
Gulfstream boom												
ABM1	116.5	112.5	104.5	104	118.5	113	107	105	118.5	113	106.5	106
ABM2	140	137	132.5	124	140.5	138	132.5	126	140.5	137.5	132	126
ABM4	128	133	127.5	124	127	130	122	119.5	128	130.5	122.5	120
ABM5	126	119	120	113	126	119.5	118	115	126	119	118	116
Learjet												
M-1												
M-2												
M-3					106.5				106.5			
M-4					104	101.5			105	104	101	
M-5												
M-6												
M-7												
M-8												
M-9					111	105	102.5		111	107	104.5	
M-10					111	104			111.5	106.5	102.5	
M-11												
M-12												

^bBlade passage frequency (BPF).

TABLE VII.—Continued.

(a) Concluded.

Microphone	Sound pressure level, dB											
	Position											
	7E				7F				7G			
	Run											
	201				200				199			
	Tone order ^b											
	BPF	2BPF	3BPF	4BPF	BPF	2BPF	3BPF	4BPF	BPF	2BPF	3BPF	4BPF
Gulfstream fuselage												
M-123					114							
M-193	122.5				122.5				123			
M-243	131.5	125	120	118.5	131.5	124.5	120	119	132	124.5	121	120
M-273	137.5	135	131	128.5	137.5	135	131	129	137.5	134.5	131	129
M-303	139.5	135.5	131	127.5	139.5	135	131.5	128	139.5	135.5	132	128
M-323	141.5	137	129	114.5	141.5	137	129.5	116	142	137	130	118.5
M-353	140	132	126	118	140	132	127	119	140.5	132	127.5	119
M-403	127	118.5	110.5		128	117.5	111		126.5	114.5	115.5	108.5
M-463	134.5	121.5	117.5	117	134.5	121.5	119	117	135	123.5	121	118
Gulfstream boom												
ABM1	118	113	106	105	118	112.5	106.5	106	117.5	112.5	106	106.5
ABM2	140.5	137	132	126.5	140.5	137	132	126	140	137	132	125
ABM4	128.5	130.5	123	121	128.5	130.5	123	121.5	130	131	124	123.5
ABM5	126	117	117.5	116	125.5	117.5	117.5	116.5	124	117.5	118.5	115.5
Learjet												
M-1												
M-2												
M-3	109.5	110.5	106		116	108.5	106		106.5			
M-4	109	110.5	105	101	116.5	107.5	104		107			
M-5												
M-6												
M-7												
M-8												
M-9	116.5	109	104.5	102	111	105			100			
M-10	116.5	109	103	100.5	110	103.5			100			
M-11												
M-12												

TABLE VII.—Continued.

(b) Case 2

Microphone	Sound pressure level, dB											
	Position											
	1B				1C				1D			
	Run											
	151				148				147			
	Tone order ^b											
	BPF	2BPF	3BPF	4BPF	BPF	2BPF	3BPF	4BPF	BPF	2BPF	3BPF	4BPF
Gulfstream fuselage												
M-123												
M-193	126.5					127				125		
M-243	138.5	132.5	128	123	138	132	128	124	138	133	127	124.5
M-273	144.5	141	138	135.5	144.5	140.5	138	136	144.5	142	137.5	135.5
M-303	146.5	143.5	140	135	146.5	143.5	139.5	134.5	146.5	144	138.5	135
M-323	147	142.5	136	131	146.5	142.5	136	131	146.5	142.5	134.5	128.5
M-353	143	138	126.5	120.5	143	138	126	123	142	137.5	127	115
M-403	139	130	117.5	124.5	138.5	129	116	125	139.5	119.5	125	120.5
M-463	135.5	127.5	118.5	118	135.5	125.5	119	114	134.5	126	116	123.5
Gulfstream boom												
ABM1	110.5	112	109	104.5	112.5	114	107	104	110.5	106	108	107.5
ABM2	139.5	136.5	132	126	139.5	136	132.5	126	140.5	137	131.5	124.5
ABM4	131	133.5	115	113.5	131.5	132	112.5	111.5	132.5	136	125.5	112
ABM5	128	128	121	118.5	127	128	120.5	120	130	126	116	114.5
Learjet												
M-1												
M-2												
M-3												
M-4												
M-5									107			
M-6									106.5			
M-7												
M-8												
M-9												
M-10												
M-11					113							
M-12												

^bBlade passage frequency (BPF).

TABLE VII.—Continued.

(b) Continued.

Microphone	Sound pressure level, dB											
	Position											
	1E						1F					
	Run											
	146				145				328			
	Tone order ^b											
	BPF	2BPF	3BPF	4BPF	BPF	2BPF	3BPF	4BPF	BPF	2BPF	3BPF	4BPF
Gulfstream fuselage												
M-123												
M-193	125				125.5				(c)			
M-243	137.5	132.5	127	123	138	132.5	127.5	123.5	137	131.5	126.5	123.5
M-273	144.5	142.5	136.5	134.5	144.5	142	138	134.5	145	141	137.5	135
M-303	146.5	144	138	134	146	143	139	134	146.5	143	137.5	133.5
M-323	146.5	142.5	135	128.5	146	142	135	130	147	142	135	126
M-353	142	137.5	126	113.5	142	137.5	125.5	120.5	143	137	130	113
M-403	139.5	122	123.5	117	138	131	114.5	126	139	127.5	121.5	122
M-463	134	126	119	121	134.5	126.5	117	117	136.5	124.5		122
Gulfstream boom												
ABM1	110	110	109	106.5	110.5	111	110	106.5	114.5	107	110	102.5
ABM2	140.5	137	130.5	124	140	137.5	133	127	139	134	130.5	122
ABM4	132.5	135	124	116.5	132	134.5	118	111	130	135.5	124.5	118
ABM5	129	126.5	116	114	127.5	127.5	119	118	129.5	121.5	114	115.5
Learjet												
M-1												
M-2												
M-3												
M-4												
M-5	112								116	111.5		
M-6	112								116.5	111		
M-7												
M-8												
M-9												
M-10												
M-11	116								122			
M-12									121.5			

^bBlade passage frequency (BPF).^cFaulty data.

TABLE VII.—Continued.

(b) Continued.

Microphone	Sound pressure level, dB											
	Position											
	1G						2B					
	Run											
	144				327				169			
	Tone order ^b											
	BPF	2BPF	3BPF	4BPF	BPF	2BPF	3BPF	4BPF	BPF	2BPF	3BPF	4BPF
Gulfstream fuselage												
M-123												
M-193	125				(c)				125.5			
M-243	138	132.5	128	123.5	137	132.5	127	123.5	137.5	130.5	126.5	123
M-273	144.5	142.5	137.5	135	145	141	137.5	134.5	144.5	140	137.5	134.5
M-303	146	143.5	138.5	134	146.5	143.5	138	133.5	146.5	141.5	139	134
M-323	146	142	135	128.5	147	142	136	125	146	140.5	134.5	129
M-353	141.5	137	126	113.5	143	137	130.5	117.5	142	135.5	126.5	117.5
M-403	139	126.5	123.5	120	134.5	130	127.5	119	139.5	122	123.5	118
M-463	134	126	117.5	121	136.5	124.5		123.5	134.5	125	119	121
Gulfstream boom												
ABM1	111	110	109	107.5	116	110	110	99	108.5	107.5	107.5	107
ABM2	140	136.5	132	124.5	139	134	131	120	139.5	135	131	124
ABM4	132	134.5	122	115	129.5	135.5	128	117.5	132	133	123.5	
ABM5	128	127	119.5	113.5	130	122	116.5	116.5	129.5	124.5	116.5	114.5
Learjet												
M-1												
M-2												
M-3												
M-4												
M-5					105.5							
M-6					106.5							
M-7												
M-8												
M-9												
M-10												
M-11												
M-12												

^bBlade passage frequency (BPF).^cFaulty data.

TABLE VII.—Continued.

(b) Continued.

Microphone	Sound pressure level, dB											
	Position											
	2C						2D					
	Run											
	168				326				167			
	Tone order ^b											
	BPF	2BPF	3BPF	4BPF	BPF	2BPF	3BPF	4BPF	BPF	2BPF	3BPF	4BPF
Gulfstream fuselage												
M-123												
M-193	125				(c)				124.5			
M-243	137	130.5	126	122.5	137	131.5	126	123	137.5	130.5	127	123
M-273	144.5	140.5	137.5	134.5	145	141	137.5	135	144.5	140	137.5	134.5
M-303	146.5	143	139	133.5	146	142.5	137.5	133.5	146	141.5	138.5	133.5
M-323	146.5	141.5	134.5	127	147	142	134	127.5	146	140.5	134.5	129.5
M-353	142.5	136.5	129.5		143	137	129	113	142	135.5	126.5	118
M-403	138	129.5	123	122.5	139.5	126.5	123	123	139.5	123	124	121
M-463	134.5	124.5	115.5	123	137	123.5	115.5	122	134.5	125	119	121
Gulfstream boom												
ABM1	114.5	101.5	109	105.5	112	100	109.5	104	108.5	108	107	105.5
ABM2	139.5	134.5	130.5	123	139.5	135	130.5	124	139.5	135	131	124
ABM4	130	135.5	126	117.5	130.5	134.5	125	117.5	132	132.5	122.5	
ABM5	129	121.5	114	114	130.5	123	117	116	129	124	116	114.5
Learjet												
M-1					108	101.5	100	98.5				
M-2												
M-3												
M-4												
M-5					112	106.5	104.5					
M-6					113	108	106	103	107			
M-7					112	114.5	110	106.5	106.5			
M-8					112	114.5	110	106.5	105			
M-9												
M-10												
M-11					120	116	111		110			
M-12					118	115.5	112					

^bBlade passage frequency (BPF).^cFaulty data.

TABLE VII.—Continued.

(b) Continued.

Microphone	Sound pressure level, dB											
	Position											
	2D						2E					
	Run											
	325				158				166			
	Tone order ^b											
	BPF	2BPF	3BPF	4BPF	BPF	2BPF	3BPF	4BPF	BPF	2BPF	3BPF	4BPF
Gulfstream fuselage												
M-123												
M-193	(c)				124.5				124			
M-243	137	132	126.5	123	138	132.5	127.5	124	137.5	130.5	126.5	123
M-273	145	141	137.5	134.5	145	142.5	137.5	136.5	144.5	140	137	134.5
M-303	146.5	143	137.5	133	146.5	144	138.5	135	146.5	141.5	138.5	133.5
M-323	147	142	134.5	127	146.5	142.5	135	129.5	146.5	140.5	134	127.5
M-353	143	137.5	130	112.5	142.5	137.5	127	116	142	135.5	126.5	114.5
M-403	135.5	127.5	123.5	120	139.5	127.5	124.5	123.5	139.5	117	123.5	119
M-463	136	125		122	134	127	118.5	123.5	135	124.5	115.5	124
Gulfstream boom												
ABM1	114.5	105	109.5	104	107.5	107.5	109	106.5	111	103	108	106.5
ABM2	139.5	134.5	131	122	140	137.5	132	126	140	135	131	124
ABM4	129	135	125	116	131.5	135	123.5	115	132	134	124	111.5
ABM5	129.5	123	117.5	113	129	126	118	115.5	129.5	122.5	116	113.5
Learjet												
M-1												
M-2									105.5			
M-3												
M-4												
M-5		117							111			
M-6									107			
M-7	122	119	114	110.5					106.5			
M-8	121.5	119.5	113	111					105			
M-9												
M-10												
M-11	123.5	123.5										
M-12	122	123	115.5	113.5								

^bBlade passage frequency (BPF).^cFaulty data.

TABLE VII.—Continued

(b) Continued.

Microphone	Sound pressure level, dB											
	Position											
	2E						2F					
	Run											
	170				324				157			
	Tone order ^b											
	BPF	2BPF	3BPF	4BPF	BPF	2BPF	3BPF	4BPF	BPF	2BPF	3BPF	4BPF
Gulfstream fuselage												
M-123												
M-193	124.5				(c)				125			
M-243	137	130.5	127	121.5	137	132	126	123	137.5	132.5	127	124
M-273	144	140	137	134	145	141	137.5	134.5	145	142	137.5	136
M-303	145.5	141.5	138	132	146.5	143	137.5	133.5	146	144	138.5	135
M-323	145	140.5	134	126.5	147	142	135	126	146	142.5	134.5	130
M-353	141	135	126	114	143	137	130.5	116	142	137	126	117
M-403	138.5	124	121	120	133	128	126.5	118.5	139.5	127.5	123	123
M-463	133.5	125.5	118.5	119	135.5	124.5		123	133.5	127	118.5	121.5
Gulfstream boom												
ABM1	111	107.5	107.5	106.5	115	106	110	103	106.5	107	110	107
ABM2	139	135.5	131	124	139	134	131	122	140	137	132	126.5
ABM4	132	133.5	122.5	110	129	135	126	116.5	132.5	135.5	124.5	113.5
ABM5	128.5	124	113.5	111	130	123	119.5	116.5	128.5	127	115.5	112.5
Learjet												
M-1	106.5											
M-2	102.5											
M-3												
M-4												
M-5	107.5				120	117	113		107			
M-6	109				122.5	119.5	116		107			
M-7	107	104.5			125	117.5	110.5	108	104.5			
M-8	107.5				124	117.5	109	106	102.5			
M-9												
M-10												
M-11	113				126	123						
M-12					124	123	115.5					

^bBlade passage frequency (BPF).^cFaulty data.

TABLE VII.—Continued.

(b) Continued.

Microphone	Sound pressure level, dB											
	Position											
	2F						3B					
	Run											
	165				323				278			
	Tone order ^b											
	BPF	2BPF	3BPF	4BPF	BPF	2BPF	3BPF	4BPF	BPF	2BPF	3BPF	4BPF
Gulfstream fuselage												
M-123												
M-193	124.5				(c)				126			
M-243	137	131	126.5	121.5	137	132	126	122.5	138	131	125.5	121.5
M-273	144.5	140.5	137.5	133.5	144.5	140.5	137	133.5	145	140.5	137	135
M-303	146	142.5	139	132.5	146.5	143	137.5	133	146.5	141.5	138	133.5
M-323	146	142	134	126.5	147	142	135	124.5	146	141	134.5	130
M-353	142	136.5	128	110	143	137	130	117	142	136	124.5	121
M-403	138	127.5	123.5	121.5	134	130	127.5	117.5	139.5	129		125
M-463	134.5	124	117	122.5	137	124.5		123	134	127.5		
Gulfstream boom												
ABM1	112.5	101	109.5	105.5	115.5	108.5	110	100	110	109.5	109	104.5
ABM2	139.5	135	131	122.5	139	134	130	120.5	140.5	136	132.5	129
ABM4	130.5	135.5	124	116	130	135.5	127	117.5	133	132.5	119.5	
ABM5	129	122	116.5	112.5	130	122.5	118	115.5	128.5	126		
Learjet												
M-1												
M-2												
M-3												
M-4												
M-5					122.5							
M-6	107				125.5							
M-7	106.5				118	109.5			102			
M-8	105.5				117	109.5			101			
M-9												
M-10												
M-11					124							
M-12					124	115.5						

^bBlade passage frequency (BPF).^cFaulty data.

TABLE VII.—Continued.

(b) Continued.

Microphone	Sound pressure level, dB											
	Position											
	3C				3D				3E			
	Run											
	277				276				275			
	Tone order ^b											
	BPF	2BPF	3BPF	4BPF	BPF	2BPF	3BPF	4BPF	BPF	2BPF	3BPF	4BPF
Gulfstream fuselage												
M-123												
M-193					127				127.5			
M-243	138	130	126	122.5	138	130.5	126.5	122.5	138	131	126	122
M-273	145	140	137.5	134.5	145.5	141	137.5	134.5	145.5	141	137	133
M-303	146.5	141.5	138.5	134.5	146.5	142	138.5	134.5	147	142	138.5	134
M-323	146	140.5	135	131	146.5	141	135	130.5	147	141	135	131
M-353	142	134.5	125.5	121	142.5	135	125.5		143	136.5	126	121.5
M-403	139	126	123.5	124.5	139.5	126.5	124	125	140	127.5	121	125
M-463	134	127.5			134.5	126.5			134.5	126		
Gulfstream boom												
ABM1	109.5	108	110	107	110.5	109	109.5	107	112	109.5	109	104.5
ABM2	141	135.5	133	128	140.5	135.5	132.5	127.5	140	135.5	131.5	127.5
ABM4	133.5	133	123.5		133	133	123		132.5	132	118	
ABM5	128.5	124.5	119		128.5	125.5	119		128	126		
Learjet												
M-1	103.5				114.5	112.5	109	105	119.5	115	108.5	107.5
M-2												
M-3												
M-4												
M-5	104				115	112.5	108.5		119	114	108.5	
M-6	104.5	103			116.5	113.5	110	108.5	121.5	118	110	106.5
M-7	111.5	110			121	117.5	111	109	120.5	118.5	109.5	105.5
M-8	111	110			121.5	118.5	112.5	108	120.5	118	109	107
M-9												
M-10												
M-11	116.5				124.5				127		107	
M-12					122	121	117		125.5	122		

^bBlade passage frequency (BPF).

TABLE VII.—Continued.

(b) Continued.

Microphone	Sound pressure level, dB											
	Position											
	3F				4B				4C			
	Run											
	274				273				272			
	Tone order ^b											
	BPF	2BPF	3BPF	4BPF	BPF	2BPF	3BPF	4BPF	BPF	2BPF	3BPF	4BPF
Gulfstream fuselage												
M-123												
M-193	127.5				127				127			
M-243	138.5	131	126.5	122	138	130	126	123.5	138	131	126	122
M-273	146	141	136.5	132	145.5	140	136.5	134.5	145.5	140	135	133
M-303	147	142.5	138	133.5	146.5	141.5	139	134.5	146.5	142	139	135
M-323	147.5	142	134.5	130	146.5	140.5	134.5	131.5	146	140.5	135	131
M-353	143.5	137	126	120.5	142.5	135	125.5	121.5	143	135.5	125	121.5
M-403	140.5	125	124	122	139.5	127.5	123	125	139.5	127		125
M-463	135	127.5			135	126.5			135	126.5		
Gulfstream boom												
ABM1	111.5	110	108	103.5	111	109	109.5	105.5	111.5	109.5	109	105
ABM2	140	135.5	131	127	139.5	135	132.5	127.5	140	135.5	131.5	128
ABM4	132	132	117.5		133	131.5	120		133	131.5	120	
ABM5	128.5	126.5			128.5	126			128.5	126.5		
Learjet												
M-1	119	115	107.5	105.5	109.5	106			109.5	108.5	107	
M-2												
M-3												
M-4												
M-5	118	112.5	107									
M-6	121	115	108	107								
M-7	120	106.5			112.5	109			114	112	107.5	
M-8	119.5	106.5			113	109	106		114	112	107.5	
M-9												
M-10												
M-11												
M-12												

^bBlade passage frequency (BPF).

TABLE VII.—Continued.

(b) Continued.

Microphone	Sound pressure level, dB											
	Position											
	4D											
	Run											
	257				271				282			
	Tone order ^b											
	BPF	2BPF	3BPF	4BPF	BPF	2BPF	3BPF	4BPF	BPF	2BPF	3BPF	4BPF
Gulfstream fuselage												
M-123												
M-193					128.5							
M-243	137.5	130	126.5	123	138	130.5	126.5	123.5	138	130.5	126	122
M-273	145	140.5	137.5	135	145.5	140	136	133	145	140.5	137.5	133
M-303	147	142	139	134.5	146.5	141.5	139	134.5	146.5	142	138.5	134
M-323	146.5	141	135	130	146.5	140.5	134.5	131.5	146.5	140.5	135	130
M-353	142.5	136	126.5		143	135.5	125.5	122.5	142.5	135.5	126	
M-403	139.5		124.5		139	127.5		126	140	125.5	124	123
M-463	134.5	126		125	135	126.5			134	127		
Gulfstream boom												
ABM1	109.5	107	109	107	111.5	110.5	108.5	104.5	109	109	109.5	106.5
ABM2	140	135.5	131.5	125	139.5	134.5	131.5	128.5	140.5	135	132	127
ABM4	132	132.5	123.5		132.5	131.5			132.5	132.5	121	
ABM5	130	124.5	121	118.5	128.5	126			128.5	124	118.5	
Learjet												
M-1	107	102			112.5	107	106		110	105.5	105.5	
M-2	106.5	102.5	97									
M-3												
M-4												
M-5												
M-6												
M-7	109	99.5	99		112.5	103.5			113	104.5		
M-8	109				112.5	103			112.5			
M-9												
M-10												
M-11												
M-12												

^bBlade passage frequency (BPF).

TABLE VII.—Continued.

(b) Continued.

Microphone	Sound pressure level, dB											
	Position											
	4E											
	Run											
	256				270				281			
	Tone order ^b											
	BPF	2BPF	3BPF	4BPF	BPF	2BPF	3BPF	4BPF	BPF	2BPF	3BPF	4BPF
Gulfstream fuselage												
M-123												
M-193					127.5				127			
M-243	137.5	130.5	126.5	122.5	138	131	127	123.5	138	130	125.5	122.5
M-273	145	141	138	135.5	145	140	136	134.5	145	140.5	137.5	133.5
M-303	147	142	139.5	134.5	146.5	141.5	139	134.5	146.5	141.5	139	134.5
M-323	147	142	135.5	129	146.5	141	136	132	146.5	141	134.5	131
M-353	142.5	136.5	127.5		143	135	125.5	122.5	142.5	135.5	125	122
M-403	139	123.5	121	124.5	139	127.5		126	139.5	127.5		125
M-463	135.5	125		124.5	135	126			134.5	127		
Gulfstream boom												
ABM1	110	107	109	106.5	111.5	110.5	108.5	105	110.5	109.5	109.5	104.5
ABM2	140	135	131.5	125	139.5	135	132	128.5	140	135	132.5	128
ABM4	131.5	133	123.5		132.5	131	117.5		133	132	120	
ABM5	130.5	124	118		128.5	126.5			128.5	125		
Learjet												
M-1	106.5				108				108.5	103		
M-2	106											
M-3												
M-4												
M-5												
M-6												
M-7	112	104	100		118	111	105.5		115.5	109	106.5	
M-8	111.5	105.5	100		118	112			115.5	109.5	107.5	
M-9												
M-10												
M-11												
M-12												

^bBlade passage frequency (BPF).

TABLE VII.—Continued.

(b) Continued.

Microphone	Sound pressure level, dB											
	Position											
	4F						4G					
	Run											
	255				280				254			
	Tone order ^b											
	BPF	2BPF	3BPF	4BPF	BPF	2BPF	3BPF	4BPF	BPF	2BPF	3BPF	4BPF
Gulfstream fuselage												
M-123												
M-193	126.5				128				126.5			
M-243	137.5	130.5	126	122	138	130.5	127.5	123.5	137.5	130	126	122
M-273	145	141	138	135	145.5	140.5	137	133	145	141	138	136
M-303	147	142.5	139.5	134	147	141.5	139	134	147	142	139.5	134.5
M-323	147	142	134.5	129.5	147	141	135	131	147	141.5	135	129.5
M-353	142.5	136	127.5		143	136	127	121	142.5	136	127.5	
M-403	138.5	124.5		125	140	126	125	124	139.5	122.5	120.5	125
M-463	135.5	124.5		125.5	134.5	125.5			135.5	124.5		124.5
Gulfstream boom												
ABM1	110.5	106	110	106.5	109	108	109	106	109	105.5	108	107
ABM2	140	135	132	126.5	139.5	135	132	128	139.5	135.5	131.5	126.5
ABM4	131.5	134.5	123		132	131.5	121		132	133.5	123.5	
ABM5	130	122.5	118		129	125	117	117	130	123	120	116
Learjet												
M-1	116	106.5	104	100.5	122	115	108	107.5	105.5			
M-2	115.5	105.5	103	100					104.5			
M-3												
M-4												
M-5												
M-6												
M-7	117	109			116	107.5			100			
M-8	117	109.5			116	107.5			100.5			
M-9												
M-10												
M-11												
M-12												

^bBlade passage frequency (BPF).

TABLE VII.—Continued.

(b) Continued.

Microphone	Sound pressure level, dB											
	Position											
	4G				5B				5C			
	Run											
	279				156				155			
	Tone order											
	BPF	2BPF	3BPF	4BPF	BPF	2BPF	3BPF	4BPF	BPF	2BPF	3BPF	4BPF
Gulfstream fuselage												
M-123												
M-193	128				124.5				125.5			
M-243	138	131	127	123	138	132.5	127	123.5	138	132.5	127	123
M-273	145.5	141	137.5	134.5	145	142	137.5	136	145	142	137.5	136
M-303	147	142	138.5	134	146.5	144	138.5	134.5	146	144	138	135
M-323	146.5	141	135	130	146.5	142.5	135	129.5	146	142.5	135	130
M-353	143	135.5	126		142	137.5	126.5	116	142	137	126.5	117
M-403	140	127.5	121	125	140	125.5	124	121	139	128.5	123.5	124
M-463	134.5	127			134	126.5	119	122.5	133.5	127	120	122.5
Gulfstream boom												
ABM1	110.5	109.5	109.5	105	108	108	109	107	107	107	110.5	106.5
ABM2	139.5	135.5	132	127.5	104.5	137	131.5	126	140.5	137.5	132.5	125.5
ABM4	132	132	119.5		132	135	123	112.5	132.5	135.5	125	114
ABM5	129	126			129	126	117	113.5	129	126.5	116.5	112
Learjet												
M-1	111											
M-2												
M-3									108			
M-4												
M-5												
M-6					103.5							
M-7	106											
M-8	106.5											
M-9												
M-10												
M-11												
M-12												

^bBlade passage frequency (BPF).

TABLE VII.—Continued.

(b) Continued.

Microphone	Sound pressure level, dB							
	Position							
	5D							
	Run							
	154				331			
	Tone order ^b							
	BPF	2BPF	3BPF	4BPF	BPF	2BPF	3BPF	4BPF
	Gulfstream fuselage							
M-123								
M-193	125.5				(c)			
M-243	138	132.5	128	123.5	137	132	127	123.5
M-273	145	142	138.5	136	145	141	137.5	135
M-303	146.5	144	139	134.5	146.5	143.5	137.5	133.5
M-323	146.5	142.5	135.5	130.5	147	142	135.5	125.5
M-353	142.5	138	126.5	119	143.5	137	130.5	116
M-403	139	130	120	125	137	130	124	120.5
M-463	134.5	127.5	119	120	136.5	124.5		123
Gulfstream boom								
ABM1	108	110	110.5	106	116	110	109.5	100
ABM2	140	137	132.5	126.5	139	134	131	121.5
ABM4	132	134.5	119.5	111.5	129	135.5	127	117.5
ABM5	128.5	128	119	115	129.5	121.5	116	114
Learjet								
M-1								
M-2								
M-3					115			
M-4					114	107.5		
M-5					120	115.5	111.5	
M-6	105.5				120.5	115	112	110.5
M-7	106							
M-8								
M-9					123	117.5	113	109.5
M-10					123.5	118	113	
M-11	113				127.5	123	119	
M-12					128	123	116	114

^bBlade passage frequency (BPF).^cFaulty data.

TABLE VII.—Continued.

(b) Continued.

Microphone	Position											
	5E											
	Run											
	153				330				332			
	Tone order ^b											
	BPF	2BPF	3BPF	4BPF	BPF	2BPF	3BPF	4BPF	BPF	2BPF	3BPF	4BPF
Gulfstream fuselage												
M-123												
M-193	126				(c)					(c)		
M-243	138.5	133	128	124	137	132	126.5	123.5	137	132	127	123
M-273	145.5	142.5	138.5	136	145	141	137.5	135	145	141	137.5	134.5
M-303	147	144	139	135	146.5	142.5	137.5	133	146.5	143	138	133.5
M-323	147	142.5	135.5	130.5	147	142	134.5	126	147	142	135	126
M-353	143	138	127.5	118	143	137	130	112	143	137	130	113.5
M-403	139.5	129.5	123	125	138.5	127.5	123	122.5	138	129	123.5	121
M-463	135	127.5	114.5	122.5	137	124.5		122	137	125		123
Gulfstream boom												
ABM1	109.5	110	110	106.5	114	106	109.5	103	114.5	107.5	110	101
ABM2	139.5	136.5	132	126	139	134	131	121.5	139	134	131	121.5
ABM4	131.5	134.5	120	116.5	130	135.5	124.5	117	130	135.5	125	117.5
ABM5	128.5	128.5	120	115.5	130	122	116.5	114.5	130	122	117	114.5
Learjet												
M-1												
M-2												
M-3					114.5	110.5	110					
M-4					112	107.5	106		109			
M-5	111				122	118	114.5	109.5	116	112.5	109.5	
M-4	106.5				121.5	117	114.5		116.5	112		
M-7												
M-8												
M-9	108.5	105			116.5	114	108		117.5	113.5	110.5	109
M-10	109.5	109			117	115.5	110		118	113.5	110	
M-11	113.5				124.5	121			124.5	117.5		
M-12					125.5	120.5			126	118	113.5	

^bBlade passage frequency (BPF).

^cFaulty data.

TABLE VII.—Continued.

(b) Continued.

Microphone	Sound pressure level, dB							
	Position							
	5F							
	Run							
	152				329			
	Tone order ^b							
	BPF	2BPF	3BPF	4BPF	BPF	2BPF	3BPF	4BPF
	Gulfstream fuselage							
M-123								
M-193	125				(c)			
M-243	137.5	132.5	126	124	137	132	126	122.5
M-273	144	141	137	136	145	141	137.5	134.5
M-303	146	143	137.5	134.5	146.5	142.5	137.5	133
M-323	146	142	134.5	128	147	142	134	126
M-353	141.5	137	126	113	143	137	129.5	111
M-403	139	124	124	118	139.5	123	122	121.5
M-463	134	126	120	121.5	137	124.5	113.5	121
Gulfstream boom								
ABM1	110.5	105.5	108.5	107	112	104	110	103.5
ABM2	141	138	131	125.5	139	134	130	123
ABM4	133	136	126	115	130	135	123.5	117.5
ABM5	129.5	125.5	118	113.5	130	121.5	117	114
Learjet								
M-1								
M-2								
M-3					115.5			
M-4					112.5	106		
M-5	106.5				122	116	110.5	
M-6	105				121	112.5		
M-7								
M-8								
M-9					115	111		
M-10					116.5	111.5		
M-11	112.5				125			
M-12					124.5	115.5		

^bBlade passage frequency (BPF).^cFaulty data.

TABLE VII.—Continued.

(b) Continued.

Microphone	Sound pressure level, dB											
	Position											
	6B				6C				6D			
	Run											
	269				268				267			
	Tone order ^b											
	BPF	2BPF	3BPF	4BPF	BPF	2BPF	3BPF	4BPF	BPF	2BPF	3BPF	4BPF
	Gulfstream fuselage											
M-123												
M-193	128				127.5				128			
M-243	138	131	126.5	123	138	130.5	127	123	138	130.5	127	123.5
M-273	145	140	136.5	134.5	144.5	139.5	136.5	134	144.5	139	137.5	136
M-303	147	142.5	138.5	134	146.5	141.5	139	135	146.5	141.5	139	134.5
M-323	147	142	135	130.5	146.5	140.5	135.5	131.5	146.5	141	135.5	132
M-353	143	136.5	126.5		142.5	135.5	126	122	143	135.5	125.5	122
M-403	140.5	123	124.5		139.5	126	123.5	123.5	139.5	127.5	122	124
M-463	135.5	127.5			135	126			136	127.5		
Gulfstream boom												
ABM1	110.5	111.5	107.5	105.5	111.5	110	107.5	105	113	111.5	107.5	104.5
ABM2	139.5	134.5	130.5	126.5	139.5	134.5	131.5	127	139.5	135	131.5	127.5
ABM4	131.5	131.5			132.5	132	119.5		132	131.5	117.5	
ABM5	128.5	125.5			129	125.5	117.5		128	126.5	117.5	
Learjet												
M-1												
M-2												
M-3									113.5	110	108.5	
M-4						107			112.5	108.5		
M-5	105				105				115	112	108	
M-6	102				104				114	111	107	
M-7												
M-8												
M-9	106.5				110	110	109	107	116	111	108	108
M-10	108				111.5	110.5	109.5		116.5	113	109.5	
M-11									120			
M-12					115				121.5			

^bBlade passage frequency (BPF).

TABLE VII.—Continued.

(b) Continued.

Microphone	Sound pressure level, dB											
	Position											
	6E				6F				7B			
	Run											
	266				265				263			
	Tone order ^b											
	BPF	2BPF	3BPF	4BPF	BPF	2BPF	3BPF	4BPF	BPF	2BPF	3BPF	4BPF
Gulfstream fuselage												
M-123												
M-193	128				127.5				127.5			
M-243	138.5	131	126	122	137.5	130	126.5	124	138	130	126.5	124
M-273	145	140.5	137	135.5	144.5	139	137.5	136	144	139.5	137.5	134.5
M-303	147	142.5	138	133.5	146	141	139	135.5	145.5	141	139	135
M-323	147	141.5	134.5	130	146	141	135.5	132.5	145.5	140	136	130
M-353	143	136.5	126		141.5	135	124.5	124.5	141.5	135	125	123.5
M-403	140			121.5	138	126		123.5	137.5	127		123.5
M-463	136.5	126.5		126	135	125.5			134.5	126		
Gulfstream boom												
ABM1	110.5	109.5	107	106.5	115.5	111	106.5		114.5	111.5	105	103.5
ABM2	140	135.5	130	125	139.5	135	131.5	129	139	134.5	132.5	128
ABM4	132	132.5	120		132	128.5	123.5		131	128	121	117
ABM5	131	124.5	117	117.5	127.5	126	121	119.5	126.5	125	120	119.5
Learjet												
M-1												
M-2												
M-3	116	113	109.5		111.5	108.5						
M-4	115.5	112.5	107		111.5	108.5						
M-5	120	116	111.5		114	110.5						
M-6	116.5	110.5	107.5	106	111.5	108.5						
M-7												
M-8												
M-9	111.5	114	109.5	106.5	113	105			109	105		
M-10	113.5	114.5	110		113.5	107.5			109.5			
M-11	121.5	118			117.5							
M-12	122				118							

^bBlade passage frequency (BPF).

TABLE VII.—Continued.

(b) Continued.

Microphone	Sound pressure level, dB											
	Position											
	7C				7D				7E			
	Run											
	262				261				260			
	Tone order ^b											
	BPF	2BPF	3BPF	4BPF	BPF	2BPF	3BPF	4BPF	BPF	2BPF	3BPF	4BPF
Gulfstream fuselage												
M-123												
M-193	128				127				126.5			
M-243	137.5	131	127	123	137.5	131	127.5	123.5	137.5	131.5	127	122
M-273	144	140.5	137.5	133	144.5	140.5	137	134.5	145	140	137.5	133
M-303	145.5	141.5	139	133.5	146	141.5	139	134	146	142	139	133.5
M-323	145	141	135.5	130	145.5	140.5	135	130	146	141	135	129
M-353	141.5	136	124	123	141.5	135	125	122.5	141.5	135.5	125.5	
M-403	137.5	128		123.5	139	127.5	120	123	139.5	127	122.5	120
M-463	134.5	126.5			134	126.5			134	125.5		
Gulfstream boom												
ABM1	113	112	105.5	104	112.5	109.5	107.5	105.5	112	110.5	107.5	105.5
ABM2	138.5	135	132.5	126.5	138.5	135	132	126	139	135	132.5	124.5
ABM4	131	130.5	119		131.5	131.5	118		131.5	132.5		
ABM5	126.5	126	117.5	119	127.5	126	118.5		127.5	126.5	117.5	
Learjet												
M-1												
M-2												
M-3	112				115	113	109		121.5	114.5	113	
M-4	111	106.5			114.5	112	108.5		120.5	114	113	108.5
M-5												
M-6												
M-7												
M-8												
M-9	118	111	107		118	113.5	110	107.5	123	115	109.5	106
M-10	119	112	108.5		118	114.5	110	107.5	123.5	115.5	111	
M-11												
M-12												

^bBlade passage frequency (BPF).

TABLE VII.—Continued.

(b) Concluded.

Microphone	Sound pressure level, dB											
	Position											
	7E				7F				7G			
	Run											
	264				259				258			
	Tone order ^b											
	BPF	2BPF	3BPF	4BPF	BPF	2BPF	3BPF	4BPF	BPF	2BPF	3BPF	4BPF
	Gulfstream fuselage											
M-123												
M-193	128				127				127			
M-243	138.5	131.5	126.5	121.5	138	131	127.5	123.5	137	131.5	127	123
M-273	144.5	140.5	137	134	145.5	140.5	136.5	134.5	144.5	141	136.5	132.5
M-303	146	141.5	137	131	146.5	142.5	139	133.5	145	142.5	139	134
M-323	145	140.5	133.5	127.5	146	141	135	129.5	145	141.5	134.5	130
M-353	141	135	125.5	120	142	136	127		141	136	125	123.5
M-403	140	125	120.5		139.5		121		136.5	129.5		
M-463	134	127			134.5	125			133.5	126.5		
Gulfstream boom												
ABM1	114	112.5		104.5	111	110.5	107	106.5	113.5	113	105	104
ABM2	138	133	130	124	139	135	131	124.5	138.5	136	132	126
ABM4	130	132			131	132.5	120		131	130.5	119.5	
ABM5	126.5	124.5			129	125			126.5	126	120	119.5
Learjet												
M-1												
M-2												
M-3	119	112			117	110			105.5			
M-4	118	111			117	109.5			106.5			
M-5												
M-6												
M-7												
M-8												
M-9	121	113			114.5				104			
M-10	121	113.5			115.5							
M-11												
M-12												

^bBlade passage frequency (BPF).

TABLE VII.—Continued.

(c) Case 3

Microphone	Sound pressure level, dB											
	Position											
	1B				1C				1D			
	Run											
	176				175				174			
	Tone order ^b											
	BPF	2BPF	3BPF	4BPF	BPF	2BPF	3BPF	4BPF	BPF	2BPF	3BPF	4BPF
Gulfstream fuselage												
M-123	114.5				113.5				114			
M-193	121.5				122.5				121.5			
M-243	127	121.5	113	109	127.5	121	113	108.5	127.5	121	113	109.5
M-273	135.5	128	122	117.5	136	128.5	122	117.5	135.5	128.5	121.5	117.5
M-303	136	131	125.5	119	136	131	126	119	135.5	131	125.5	119
M-323	139.5	132.5	125.5	114	139.5	132.5	125.5	115	139.5	132.5	125.5	115.5
M-353	136.5	128	117.5	107.5	136.5	128.5	117		136.5	128	117	107.5
M-403	118	119.5	115		119	119.5	114.5		118.5	119.5	114.5	
M-463	132	110	114		132	110.5	114		131.5	109.5	113	
Gulfstream boom												
ABM1	113	105	98	97.5	112.5	104.5	97.5	96.5	112.5	105	98	97
ABM2	136.5	130.5	126	120.5	136.5	130	126	120	136.5	130.5	126	120.5
ABM4	125	120.5	112.5	110	125	120	112	110	125	120.5	112	110
ABM5	119.5	115.5	114.5	114.5	120	115	114.5	114.5	119.5	115	114	114
Learjet												
M-1												
M-2												
M-3												
M-4												
M-5					104				106	104		
M-6					104				106	103.5	100.5	
M-7												
M-8												
M-9												
M-10									110			
M-11					109							
M-12												

^bBlade passage frequency (BPF).

TABLE VII.—Continued.

(c) Continued.

Microphone	Sound pressure level, dB											
	Position											
	1E				1F							
	Run											
	173				172				334			
	Tone order ^b											
	BPF	2BPF	3BPF	4BPF	BPF	2BPF	3BPF	4BPF	BPF	2BPF	3BPF	4BPF
Gulfstream fuselage												
M-123	114.5				113.5							
M-193	122.5				121.5				(c)			
M-243	127	121	113	110	127.5	121	123	109.5	127	119.5	113	108
M-273	135.5	128.5	122.5	117.5	135.5	129	123	118.5	136.5	129	123.5	118
M-303	135.5	131	125.5	118.5	135.5	131.5	126	119.5	135.5	130.5	127.5	120
M-323	139.5	133	125.5	115	139.5	133	125.5	115.5	140.5	132	126.5	117.5
M-353	136.5	128.5	118		136.5	128	117	106.5	138	129.5	119	
M-403	119.5	119.5	114.5		119.5	119.5	114.5		126	114.5	113	110.5
M-463	131.5	110	113.5		131.5	110.5	113.5		131.5	115.5	114.5	
Gulfstream boom												
ABM1	112.5	105	97.5	97.5	113	105	97.5	97	113	105	99	96.5
ABM2	136.5	130.5	126	120.5	136.5	130	126	120	136.5	130	127	122.5
ABM4	125	120.5	112	110	125	120.5	111.5	110	125	120		110.5
ABM5	119.5	115.5	114.5	114.5	119.5	116	114.5	114.5	122	115	115	113
Learjet												
M-1												
M-2												
M-3												
M-4												
M-5	109.5				103.5				120	109.5	105	
M-6	110	102.5			102				120.5	109		
M-7												
M-8												
M-9												
M-10												
M-11	112								122			
M-12	113.5								122.5	110		

^bBlade passage frequency (BPF).^cFaulty data.

TABLE VII.—Continued.

(c) Continued.

Microphone	Sound pressure level, dB											
	Position											
	1G						2B					
	Run											
	171				333				186			
	Tone order ^b											
	BPF	2BPF	3BPF	4BPF	BPF	2BPF	3BPF	4BPF	BPF	2BPF	3BPF	4BPF
Gulfstream fuselage												
M-123	113.5								114			
M-193	122				(c)				122.5			
M-243	127.5	120	112.5		127	120	111		127	122	112.5	109.5
M-273	136	127.5	122.5	117	135.5	126.5	121.5	116	135.5	129	122	119
M-303	136	130	125.5	118.5	135.5	129.5	124.5	117.5	136	132	126	120
M-323	139.5	131.5	125.5	114.5	139	131.5	125.5	113.5	139.5	133	125	114.5
M-353	136.5	127	117		137	127	116		136.5	129	117	108
M-403	122	117	113		120.5	118.5	110.5	109.5	116.5	120	113	
M-463	131	110.5	114		132	111	114.5		131.5		112.5	
Gulfstream boom												
ABM1	114.5	106.5	100	96.5	113	104.5	100	97	112.5	105	95	97
ABM2	137	130.5	127.5	122.5	137	130	127	123	136	130	125	120.5
ABM4	126	121	110	111.5	125	120.5		114	124	120.5	111	109.5
ABM5	120.5	115.5	114	114	121	114.5	115	114.5	118.5	116	113	114
Learjet												
M-1												
M-2												
M-3												
M-4												
M-5					111.5							
M-6					111							
M-7									98.5			
M-8									98.5			
M-9												
M-10												
M-11					115							
M-12					114							

^bBlade passage frequency (BPF).

^cFaulty data.

TABLE VII.—Continued.

(c) Continued.

Microphone	Sound pressure level, dB											
	Position											
	2C						2D					
	Run											
	185				322				184			
	Tone order ^b											
	BPF	2BPF	3BPF	4BPF	BPF	2BPF	3BPF	4BPF	BPF	2BPF	3BPF	4BPF
Gulfstream fuselage												
M-123	113								113			
M-193	121.5				(c)				122			
M-243	126.5	122	111.5	108	127.5	119	113	108	126.5	121.5	112	107.5
M-273	135	128	121.5	118	136	127	122	118.5	135.5	128	122	118
M-303	135.5	131	125	119	136	129	124	117.5	136	131.5	125	119
M-323	139	133	126	114	140	132	125	114	139	132.5	126	114
M-353	136	128.5	116	108	137.5	127	114.5	110	136.5	128.5	116	107
M-403	113	120.5	112.5	109.5	115	123	117		115	120	113.5	109
M-463	131		113.5		133	112.5	112.5		131		113.5	
Gulfstream boom												
ABM1	113.5	105.5	97	97	110.5	105	98.5	97	113	105.5	96.5	96.5
ABM2	136	130.5	126	121.5	136	128.5	125	121	136	130.5	125.5	121
ABM4	124.5	121	111	109	124.5	119	111.5	111.5	124.5	121	112	109
ABM5	118	117	113.5	115	120	114.5	114	115	118.5	117	113	113.5
Learjet												
M-1					115	108	105	101.5	102			
M-2									97			
M-3												
M-4												
M-5	103				119	113	104		105.5			
M-6	101.5	100.5			120	114.5	108.5	106	105.5	100.5		
M-7	100.5	98			120.5	116.5	111	106.5	105.5	101.5		
M-8	101	100			120.5	116.5	110.5	106	106.5	101.5		
M-9												
M-10												
M-11					126.5	117.5			109.5			
M-12					125.5	117.5	111	106				

^bBlade passage frequency (BPF).^cFaulty data.

TABLE VII.—Continued.

(c) Continued.

Microphone	Sound pressure level, dB											
	Position											
	2D				2E							
	Run											
	321				183				320			
	Tone order ^b											
	BPF	2BPF	3BPF	4BPF	BPF	2BPF	3BPF	4BPF	BPF	2BPF	3BPF	4BPF
Gulfstream fuselage												
M-123					114							
M-193	(c)				122.5				(c)			
M-243	128	119	112.5	108.5	127.5	121.5	113	110	126.5	118.5	112	108.5
M-273	136.5	127.5	121.5	118	136	129	123	119	135.5	126	120	117
M-303	135.5	130	124.5	118.5	136	132	126.5	120	135.5	129	123	117
M-323	140	131.5	124.5	114.5	139.5	134	126	117	139.5	131	123.5	113
M-353	137.5	127.5	116.5		136.5	129	118		137.5	127.5	115	109
M-403	122	120	113		121	118.5	114.5			123	116.5	
M-463	132.5	114	113		131.5	111	113.5		133	111	111.5	108
Gulfstream boom												
ABM1	111.5	106	98.5	98.5	112.5	105	97	97	111.5	106	100	96
ABM2	136.5	130	125.5	122.5	136.5	131	125.5	121	136	129	125.5	121.5
ABM4	125	120	108	113	124.5	120	112	109	125	120	112	111.5
ABM5	121.5	115.5	113.5	114.5	119	116	113.5	115	119	115.5	115	114.5
Learjet												
M-1	117.5	110.5	106	103.5	101				116	109.5	104.5	100.5
M-2					101							
M-3												
M-4												
M-5	122	116	108.5	106	106	102			121	107.5	109	105.5
M-6	123.5	118	110.5	106	106	101.5			124	112	109	108
M-7	125	117	110	106	105	99			121.5	113	104	100.5
M-8	125	117	109.5	105.5	105	101			121	113	104	
M-9												
M-10												
M-11	128	119.5	112		108.5				126.5	115		
M-12	127	119	112.5	106.5					125.5	117	110	

^bBlade passage frequency (BPF).^cFaulty data.

TABLE VII.—Continued.

(c) Continued.

Microphone	Sound pressure level, dB											
	Position											
	2F						3B					
	Run											
	182				319				252			
	Tone order ^b											
	BPF	2BPF	3BPF	4BPF	BPF	2BPF	3BPF	4BPF	BPF	2BPF	3BPF	4BPF
Gulfstream fuselage												
M-123	114.5											
M-193	122.5				(c)				125			
M-243	127.5	122.5	113	110.5	128	120	112.5	107.5	127.5	121	113.5	109
M-273	136	129.5	122.5	119.5	136	127.5	121	116	135.5	129	122	119
M-303	136	132	126	120.5	135.5	130	124	116	136.5	132	126.5	123
M-323	139.5	133	126	116.5	140	132	124.5	113	140.5	134	127	
M-353	136.5	129.5	117		137.5	127.5	114.5	108.5	137	130		
M-403	119.5	119.5	115.5		118.5	121	114.5		122	123		
M-463	131.5	111	113		133	112.5	113.5		131			
Gulfstream boom												
ABM1	111.5	104.5	94	96.5	111.5	106	99	96.5	113	106		
ABM2	136	130.5	124.5	120.5	136.5	130	125.5	121	136.5	131	126	122
ABM4	124	120	111	109	125	120	109.5	112	125.5	120		
ABM5	119	117.5	114	114	121	116	114.5	114		118		
Learjet												
M-1	100				116	111.5	102		101			
M-2	98.5								97			
M-3												
M-4												
M-5	102.5				118	113	106.5	103				
M-6	101.5				120	113.5	105.5	105				
M-7	100.5				111	105.5			104.5			
M-8	101.5				110.5	105.5			106			
M-9												
M-10												
M-11	107.5				125	113						
M-12					124	112.5						

^bBlade passage frequency (BPF).^cFaulty data.

TABLE VII.—Continued.

(c) Continued.

Microphone	Sound pressure level, dB											
	Position											
	3C				3D				3E			
	Run											
	251				250				249			
	Tone order ^b											
	BPF	2BPF	3BPF	4BPF	BPF	2BPF	3BPF	4BPF	BPF	2BPF	3BPF	4BPF
Gulfstream fuselage												
M-123												
M-193					124.5				125			
M-243	127	121	113	110	127.5	122	113	110	127	121	113	
M-273	135.5	128.5	121	118.5	135.5	129	122	119	135.5	128	121.5	117.5
M-303	136.5	131.5	126.5		136.5	132	126	121.5	136.5	131.5	125	
M-323	140.5	134	126.5		140.5	134.5	127		140.5	132.5	127	
M-353	137	130			137	130			137.5	129.5		
M-403		123			121	123	118.5			124.5		
M-463	131				131				131.5			
Gulfstream boom												
ABM1	113	106			113	105			113	107		
ABM2	136.5	131	126	122	136.5	130.5	125.5	121.5	136.5	130.5	126	121
ABM4	125.5	120.5			125.5	120.5			126	120	116.5	
ABM5		119			117.5	119.5			117.5	118		
Learjet												
M-1	105	102.5	100		110.5	105.5	100.5		112	108	102	
M-2	105	101.5	99.5		109.5	105	99	97	112	108	101.5	99
M-3												
M-4												
M-5	106				110.5	104	102.5		111	104.5	102.5	
M-6	107	103			112	107	102		113	106.5	103.5	
M-7	111.5	108	103	101	113	109.5	104	100.5	116	110	99.5	
M-8	112	109.5	102.5	101	113.5	110.5	104.5		116	110.5		
M-9												
M-10												
M-11	114.5				116.5				117			
M-12	113				116.5	114.5			117			

^bBlade passage frequency (BPF).

TABLE VII.—Continued.

(c) Continued.

Microphone	Sound pressure level, dB											
	Position											
	3F				4B				4C			
	Run											
	248				246				245			
	Tone order ^b											
	BPF	2BPF	3BPF	4BPF	BPF	2BPF	3BPF	4BPF	BPF	2BPF	3BPF	4BPF
Gulfstream fuselage												
M-123												
M-193	124.5				125.5							
M-243	128	121	115	109	126.5	120.5	113		128	121.5	113.5	111
M-273	136	129	122.5	118.5	135.5	128.5	122.5	117.5	135.5	129	122.5	119
M-303	136.5	132	126		136.5	131.5	126		136	132	127	123
M-323	140.5	134	126.5		140.5	133	127		140.5	134	127.5	
M-353	137.5	130			137.5	129.5			137	130		
M-403	121	123				124.5			122.5	120		
M-463	131.5				131.5				131			
Gulfstream boom												
ABM1	112.5	106.5			113	106			113	107.5		
ABM2	136.5	130.5	126	121	136.5	130	126.5	120	136.5	131.5	126	122
ABM4	125.5	120			126	120	117		125.5	120		
ABM5	118	118.5		117		118	116.5		117.5	116.5		117.5
Learjet												
M-1	110	100							106	100.5		
M-2	109	99							105	97.5		
M-3												
M-4												
M-5	108.5											
M-6	109	100.5										
M-7	113	98.5			98.5				110	102	100.5	
M-8	113								110.5	101.5	101	
M-9												
M-10												
M-11	114											
M-12	115											

^bBlade passage frequency (BPF).

TABLE VII.—Continued.

(c) Continued.

Microphone	Sound pressure level, dB											
	Position											
	4D				4E				4F			
	Run											
	244				243				242			
	Tone order ^b											
	BPF	2BPF	3BPF	4BPF	BPF	2BPF	3BPF	4BPF	BPF	2BPF	3BPF	4BPF
Gulfstream fuselage												
M-123												
M-193					124.5							
M-243	127.5	121	113.5	110	127	120.5	112.5	109	128	121.5	115	111.5
M-273	135.5	128.5	122	117.5	135.5	128.5	121	117	136.5	130.5	123.5	120
M-303	136	131.5	126	122	135.5	131.5	125.5	121	135.5	133	127.5	123.5
M-323	140.5	133	126.5		140	133.5	127		141	134	127.5	
M-353	137	129			137	129			137.5	130.5		
M-403		122.5				123			125.5			
M-463	131				131				131			
Gulfstream boom												
ABM1	113.5	107.5	103		113	107.5			113	107.5		
ABM2	137	131	127	122	136.5	131	126.5	122	136.5	131	125.5	122.5
ABM4	126.5	121			126	121			125.5	119.5		
ABM5	118	117.5	117	117.5	117.5	118.5			118.5	118.5		
Learjet												
M-1	110	103.5	102		111	105.5	102		112.5	106	100	
M-2	109.5	103.5	101.5	99	111	105	100		112	106	98	
M-3												
M-4												
M-5												
M-6												
M-7	110.5	107	100		111.5	105	98		113	99		
M-8	110.5	106.5	102.5		111	106.5			112			
M-9												
M-10												
M-11												
M-12												

^bBlade passage frequency (BPF).

TABLE VII.—Continued.

(c) Continued.

Microphone	Sound pressure level, dB							
	Position							
	4G				5B			
	Run							
	241				181			
	Tone order ^b							
	BPF	2BPF	3BPF	4BPF	BPF	2BPF	3BPF	4BPF
Gulfstream fuselage								
M-123					113			
M-193					121.5			
M-243	126.5	120.5	112.5		127.5	122	113	110
M-273	135	128.5	121	117.5	136	129.5	122.5	119.5
M-303	136	131.5	126	122	136	132	126.5	120.5
M-323	140	133	127		139.5	133	126	117.5
M-353	137	129	121.5		136.5	129.5	117.5	
M-403		123.5			120.5	118	115	
M-463	131				131	111	113	
Gulfstream boom								
ABM1	112.5	107			113.5	105	97	96.5
ABM2	136.5	131	126	121	136.5	130.5	125.5	121
ABM4	126	121	117		125	120	110.5	109
ABM5		119		117	119	115.5	113	115
Learjet								
M-1	106.5							
M-2	105							
M-3								
M-4								
M-5								
M-6								
M-7	102							
M-8	103							
M-9								
M-10								
M-11								
M-12								

^bBlade passage frequency (BPF).

TABLE VII.—Continued.

(c) Continued.

Microphone	Sound pressure level, dB							
	Position							
	5C							
	Run							
	180				338			
	Tone order ^b							
	BPF	2BPF	3BPF	4BPF	BPF	2BPF	3BPF	4BPF
	Gulfstream fuselage							
M-123	113.5				114			
M-193	122				(c)			
M-243	126.5	120.5	112	107.5	127.5	120	111	108
M-273	135.5	128	122	117	136	127.5	120.5	116.5
M-303	136	131	125	117.5	136	130	124	117.5
M-323	139.5	132.5	126	114.5	140	131.5	124.5	114.5
M-353	136.5	128.5	118	109	137.5	127.5	115.5	
M-403	113.5	120.5	114.5	109	122.5	119	110.5	110
M-463	131.5		113		132.5	112.5	113.5	
Gulfstream boom								
ABM1	113.5	105	98	97	112.5	105	98.5	98
ABM2	136.5	130.5	126.5	120.5	137	130	125	122
ABM4	125.5	120.5	113	110	125	120.5		113
ABM5	118	117	114	115	122	114.5	114	114.5
Learjet								
M-1								
M-2								
M-3					111	102.5	101	
M-4	102				110	102		
M-5	104.5				115.5	108.5	107	105
M-6	103				115.5	108.5	107.5	104
M-7								
M-8								
M-9	105.5	100.5			116.5	111.5	108	105.5
M-10	105				117	112	107.5	104.5
M-11	108.5				122.5	115		
M-12					123	112.5		

^bBlade passage frequency (BPF).^cFaulty data.

TABLE VII.—Continued.

(c) Continued.

Microphone	Sound pressure level, dB											
	Position											
	5D						5E					
	Run											
	179				337				178			
	Tone order ^b											
	BPF	2BPF	3BPF	4BPF	BPF	2BPF	3BPF	4BPF	BPF	2BPF	3BPF	4BPF
Gulfstream fuselage												
M-123	113								113.5			
M-193	122				(c)				122			
M-243	127	121	112	108	127.5	120	111.5		126.5	121	112	108
M-273	135.5	128.5	122	117.5	137	128.5	121.5	117.5	135.5	128.5	122	117.5
M-303	136	131	125	118.5	135.5	130	125	119.5	136	131	125.5	118.5
M-323	139.5	132.5	125.5	113.5	140.5	131.5	124.5	116.5	139.5	132.5	125.5	115
M-353	136.5	128.5	117.5	109	137.5	129.5	117		136.5	128.5	117	108.5
M-403	116	120.5	114.5		126	115.5	111.5	110.5	116.5	120.5	104	109.5
M-463	131.5		113.5		132	115	114		132	109.5	113	
Gulfstream boom												
ABM1	113.5	105.5	98	97.5	113.5	105	98	96.5	112.5	105	96.5	97.5
ABM2	136.5	130.5	126	121	137	130	125.5	123	136	130	125.5	120.5
ABM4	125.5	121	112.5	110	125	120.5		112.5	125	120.5	112.5	110
ABM5	118.5	117	114	115	122.5	114.5	114.5	113.5	119	116.5	113.5	114
Learjet												
M-1												
M-2												
M-3	102.5				109	104			102.5			
M-4					109	104	101.5		103			
M-5	105	103.5			117.5	113.5	107.5	104.5	107.5	102		
M-6	103				117	111.5	106.5	104.5	107			
M-7												
M-8												
M-9	105.5	100.5			120	112	105	103.5	106			
M-10	105.5				120	112.5	104.5	105	106.5			
M-11	108.5				122	118			111			
M-12					122.5	117.5						

^bBlade passage frequency (BPF).^cFaulty data.

TABLE VII.—Continued.

(c) Continued.

Microphone	Sound pressure level, dB											
	Position											
	5E						5F					
	Run											
	336				177				335			
	Tone order ^b											
	BPF	2BPF	3BPF	4BPF	BPF	2BPF	3BPF	4BPF	BPF	2BPF	3BPF	4BPF
Gulfstream fuselage												
M-123					112.5				113.5			
M-193	(c)				122.5				(c)			
M-243	127	120	112.5		127.5	121.5	113.5	108.5	127	120	113	
M-273	136.5	128.5	123.5	118	136	128.5	122.5	117.5	135.5	127.5	122	116
M-303	135.5	130.5	127	120	136	131	126.5	119	135.5	130	125	117
M-323	140	131.5	126.5	117.5	140	133	126.5	115	139	132	126	113.5
M-353	137.5	129.5	118.5		137	128.5	117.5		137	127.5	116.5	
M-403	126	115.5	113	110	121.5	118	115		121.5	119	111.5	109.5
M-463	131.5	114.5	114.5		131.5	111	113.5		132	112.5	115	
Gulfstream boom												
ABM1	113	104.5	99.5	96	113.5	105.5	98.5	97.5	112.5	105	99.5	97.5
ABM2	136.5	130	127	122.5	137	130.5	126.5	120.5	136.5	130	126.5	122
ABM4	125	120.5		111	125.5	120.5	110	110	125	121	105.5	112
ABM5	121.5	115	115	113.5	120	115	114.5	114.5	121	115	114.5	114.5
Learjet												
M-1												
M-2												
M-3	112.5	103	102.5		103				115.5	105		
M-4	108.5	104.5	102						113	101.5		
M-5	122	112	107		104				121.5	110		
M-6	121.5	109.5	108.5		103.5				121	109.5		
M-7												
M-8												
M-9	117	106.5			103.5	101			110.5	103.5		
M-10	116.5	107			106				110			
M-11	125	113.5			109				124.5			
M-12	125.5	112.5							124			

^bBlade passage frequency (BPF).^cFaulty data.

TABLE VII.—Continued.

(c) Continued.

Microphone	Sound pressure level, dB											
	Position											
	6B				6C				6D			
	Run											
	239				238				237			
	Tone order ^b											
	BPF	2BPF	3BPF	4BPF	BPF	2BPF	3BPF	4BPF	BPF	2BPF	3BPF	4BPF
Gulfstream fuselage												
M-123												
M-193	124.5				124.5				124.5			
M-243	127.5	120.5	113	109.5	128	121	114.5	109.5	128	121.5	115	110
M-273	135.5	128.5	122	117.5	136	129	123	118	136	128.5	123	118.5
M-303	136	131.5	127	122	136	131.5	127	122	136.5	132	127	121.5
M-323	141	133	126.5		140.5	134	128		140.5	134	127.5	
M-353	137.5	129	121		137	129			137.5	128.5	121	
M-403		123.5			122	122.5			121	123.5		
M-463	131.5				131				132			
Gulfstream boom												
ABM1	113	106.5			113.5	107			113	106.5	102.5	
ABM2	136.5	130.5	126	121.5	136.5	130.5	126.5	121	137	130	127	120.5
ABM4	126	121	116		126	120	116.5		126	120	116.5	
ABM5	116.5	118.5	116	117	117.5	118	116	117	117.5	118	117.5	117.5
Learjet												
M-1												
M-2												
M-3					106.5				108.5	104.5		
M-4					106.5				108.5	104	101.5	
M-5					107.5	102			110	105.5	102.5	
M-6					108				109.5	101.5		
M-7												
M-8												
M-9	103				113	105.5	100		118.5	107.5	102.5	102
M-10	105				114	106.5			119	108	104	
M-11					114				116.5			
M-12					114.5				115.5			

^bBlade passage frequency (BPF).

TABLE VII.—Continued.

(c) Continued.

Microphone	Sound pressure level, dB							
	Position							
	6E				6F			
	Run							
	236				235			
	Tone order ^b							
	BPF	2BPF	3BPF	4BPF	BPF	2BPF	3BPF	4BPF
Gulfstream fuselage								
M-123								
M-193					124			
M-243	128.5	120.5	115	110	127.5	121	113.5	
M-273	136.5	128.5	123.5	118	135.5	128.5	122.5	118.5
M-303	136	132	127.5		136	131.5	126.5	
M-323	141	133.5	129		140	134	127.5	
M-353	138	128.5	121.5		137	128.5		
M-403	124.5	121.5				123		
M-463	131.5				131.5			
Gulfstream boom								
ABM1	113	107.5			113	107.5	102	
ABM2	137	131	127	121	136.5	131	126	121.5
ABM4	126	120	116		125.5	120		
ABM5	118.5	117.5	116	117	117	117.5		117
Learjet								
M-1								
M-2								
M-3	115.5	106			114	107		
M-4	115	106.5			113	106.5		
M-5	117	107	102		115	108		
M-6	116	103.5			114	105.5		
M-7								
M-8								
M-9	117	109	103	99.5	105.5	106.5		
M-10	117	109.5	103.5		106	107		
M-11	119.5				116.5			
M-12	119.5				115.5			

^bBlade passage frequency (BPF).

TABLE VII.—Continued.

(c) Continued.

Microphone	Sound pressure level, dB							
	Position							
	7B				7C			
	Run							
	234				233			
	Tone Order ^b							
	BPF	2BPF	3BPF	4BPF	BPF	2BPF	3BPF	4BPF
Gulfstream fuselage								
M-123								
M-193					124			
M-243	127	120.5	113	109.5	127.5	120.5	113	109
M-273	135.5	128	121.5	117	135.5	127.5	122	117
M-303	135.5	131	125		136	131.5	126	
M-323	140.5	133	127		140.5	133.5	127	
M-353	137	128			137.5	128.5	121	
M-403		124.5				124		
M-463	131.5				131.5			
Gulfstream boom								
ABM1	113.5	107.5	102.5		114	107.5		
ABM2	136.5	130.5	127	121	137	130.5	127	120.5
ABM4	127	121	116.5		127	120.5	117	
ABM5	117	118	117.5	117.5	117.5	118	116.5	117
Learjet								
M-1								
M-2								
M-3					110.5			
M-4					110			
M-5								
M-6								
M-7								
M-8								
M-9	103				114.5	102	100.5	
M-10	105				114.5	103.5		
M-11								
M-12								

^bBlade passage frequency (BPF).

TABLE VII.—Continued.

(c) Continued.

Microphone	Sound pressure level, dB											
	Position											
	7D						7E					
	Run											
	232				231				240			
	Tone order ^b											
	BPF	2BPF	3BPF	4BPF	BPF	2BPF	3BPF	4BPF	BPF	2BPF	3BPF	4BPF
Gulfstream fuselage												
M-123												
M-193												
M-243	127	120.5	113		128.5	120.5	114	110	127.5	121.5	113	109
M-273	135.5	128	121.5	117	136.5	128.5	123.5	118.5	134.5	129	123.5	119
M-303	136	131.5	126		136.5	132	127.5		135	131	126.5	123
M-323	140	132.5	126.5		140.5	133	128		139	132.5	127	
M-353	137	128	121.5		137.5	128.5			135	127		
M-403		125			121.5	123.5				120		
M-463	131.5				131.5				129.5			
Gulfstream boom												
ABM1	114	107	102.5		112.5	106.5			113	107.5		
ABM2	136.5	130.5	127	121	136.5	130	126	120	135	130	125.5	121
ABM4	127	121	116.5		126	120	117.5		124.5	120		
ABM5	117	118	117		118	118.5	116	117	116.5	118		
Learjet												
M-1												
M-2												
M-3	111	104	103.5		113	108.5			112	106.5	103	
M-4	111	103.5			113	109			111.5	106.5	103	
M-5												
M-6												
M-7												
M-8												
M-9	115	109	103.5		116	104			115	102		
M-10	114.5	110.5	103		116.5	105	102.5		116	103.5		
M-11												
M-12												

^bBlade passage frequency (BPF).

TABLE VII.—Continued.

(c) Concluded.

Microphone	Sound pressure level, dB							
	Position							
	7F				7G			
	Run							
	230				229			
	Tone order ^b							
	BPF	2BPF	3BPF	4BPF	BPF	2BPF	3BPF	4BPF
Gulfstream fuselage								
M-123								
M-193					125			
M-243	128.5	120	113	110	127.5	120.5	114	109.5
M-273	136.5	127	122.5	118	136	128	122.5	117.5
M-303	136	130.5	127		136	131.5	126	
M-323	141	132.5	127.5		140.5	133	127	
M-353	138	127.5	121		137.5	128	121	
M-403	122	123	119		120	125		
M-463	132				132			
Gulfstream boom								
ABM1	114	106.5	103		113.5	107.5		
ABM2	137	129.5	126.5	123	136.5	130	127	120.5
ABM4	127	120	116		127	121	117	
ABM5	119	117.5		116.5	117.5	118.5	117	117
Learjet								
M-1								
M-2								
M-3	115	107	102					
M-4	115.5	107.5						
M-5								
M-6								
M-7								
M-8								
M-9	113.5							
M-10	113.5							
M-11								
M-12								

^bBlade passage frequency (BPF).

TABLE VII.—Continued.

(d) Case 4

Microphone	Sound pressure level, dB											
	Position											
	1B			1C				1D				
	Run											
	164				163				162			
	Tone order ^b											
	BPF	2BPF	3BPF	4BPF	BPF	2BPF	3BPF	4BPF	BPF	2BPF	3BPF	4BPF
Gulfstream fuselage												
M-123												
M-193	122.5				122				122.5			
M-243	129.5	120	111.5		129	119.5	112.5	108.5	129.5	120	114	
M-273	138.5	129.5	123	115	138	128	122.5	116	138.5	129.5	124	116
M-303	138.5	132.5	124.5	115.5	138	132	124.5	117	138.5	133	125.5	117
M-323	141	132.5	124.5	114.5	140.5	132	124.5	114	141	133	125	114.5
M-353	139	127.5	110	114	138.5	126.5	110	114	139	128	111	114
M-403	126.5	128.5		112	126.5	128		112	125.5	128.5	111	112
M-463	132.5	120	116.5		132	120	116		132	120	116	
Gulfstream boom												
ABM1	112	108	100	94	112	107.5	99.5	95	112.5	108	100	94.5
ABM2	136.5	130	125	120.5	136.5	129.5	125	121.5	136.5	130	125.5	121
ABM4	124.5	122	106.5	114.5	124.5	121.5	107.5	115	124	122.5	104.5	115.5
ABM5	120	117.5	117	114	120	116.5	117.5	113.5	121	117.5	117.5	113.5
Learjet												
M-1												
M-2												
M-3												
M-4												
M-5					105.5				105	105.5		
M-6					105				106.5			
M-7												
M-8												
M-9												
M-10												
M-11									110			
M-12												

^bBlade passage frequency (BPF).

TABLE VII.—Continued.

(d) Continued.

Microphone	Sound pressure level, dB											
	Position											
	1E				1F							
	Run											
	161				160				314			
	Tone order ^b											
	BPF	2BPF	3BPF	4BPF	BPF	2BPF	3BPF	4BPF	BPF	2BPF	3BPF	4BPF
	Gulfstream fuselage											
M-123												
M-193	122				122				(c)			
M-243	129	120	112	108	129	120	112.5		130	121.5	115	111
M-273	138	128.5	122.5	116.5	138	128.5	122	115	138	130	126	121.5
M-303	138.5	132	124.5	117	138	132	124	116	138.5	133	126.5	123
M-323	140.5	132	124	114	140.5	132.5	124	113	141.5	132.5	127	118
M-353	138.5	127	113	112.5	138.5	127	112	112.5	138	130	118	110
M-403	124.5	127	113	110.5	125.5	128.5	110	110	116.5	124	118	108
M-463	132	119.5	115		132	120	115.5		132.5	116.5	113	
Gulfstream boom												
ABM1	113	107.5	99.5	95.5	112.5	108	100	94.5	114	104.5	91	96
ABM2	136.5	129.5	125	121	136.5	130	124.5	120	137	129.5	125	119.5
ABM4	124.5	122	104	114	124.5	122	107.5	114	123.5	120	114	106
ABM5	121.5	116.5	116.5	112.5	120.5	116	116	112	119.5	115	110	110
Learjet												
M-1												
M-2												
M-3												
M-4												
M-5	108.5								121	106.5		
M-6	108				103.5				121	106		
M-7												
M-8												
M-9												
M-10												
M-11	112.5								120.5			
M-12									120.5			

^bBlade passage frequency (BPF).^cFaulty data.

TABLE VII.—Continued.

(d) Continued.

Microphone	Sound pressure level, dB											
	Position											
	1G						5C					
	Run											
	159				313				318			
	Tone order ^b											
	BPF	2BPF	3BPF	4BPF	BPF	2BPF	3BPF	4BPF	BPF	2BPF	3BPF	4BPF
Gulfstream fuselage												
M-123												
M-193	122				(c)				(c)			
M-243	129	119.5	109.5	108.5	131.5	122	116.5	112	130	119.5	115.5	110
M-273	137.5	127	121	114	138	131	127.5	123.5	137.5	130	126.5	121
M-303	137.5	130.5	123	114	138.5	134	128	123.5	138	132	127	123
M-323	139.5	131	122.5	112.5	141.5	133.5	128	118.5	141	131.5	127.5	118.5
M-353	138	124.5	111.5	112.5	137.5	130	119.5		137	128.5	118.5	
M-403	127.5	128.5	113.5	108.5		123	119	110		122	116	
M-463	131	120	114		133	116	113		132	114.5	114.5	
Gulfstream boom												
ABM1	112.5	107.5	100	93.5	113	103.5		94	114.5	105.5	96	96.5
ABM2	136	128.5	124.5	120.5	136.5	129.5	125	118.5	137	129.5	127.5	121
ABM4	125	120.5	109.5	114.5	122.5	120	112	107	124.5	120	113	109
ABM5	119.5	114	115.5	112.5	120	115	109.5	109.5	119	114.5	112	112
Learjet												
M-1												
M-2												
M-3									104	106.5		
M-4									103	105		
M-5					108.5				108	113		
M-6					108.5				107.5	113	107.5	
M-7												
M-8												
M-9									119	114	108	106.5
M-10									119.5	114	108	106
M-11									119.5	118		
M-12					114				119	116		

^bBlade passage frequency (BPF).^cFaulty data.

TABLE VII.—Continued.

(d) Continued.

Microphone	Sound pressure level, dB											
	Position											
	5D				5E				5F			
	Run											
	317				316				315			
	Tone order ^b											
	BPF	2BPF	3BPF	4BPF	BPF	2BPF	3BPF	4BPF	BPF	2BPF	3BPF	4BPF
Gulfstream fuselage												
M-123												
M-193	(c)				(c)				(c)			
M-243	129.5	120	114.5	110	130.5	120	116.5	111	129.5	120	115	111
M-273	137.5	129.5	125	120.5	137.5	130	127.5	123	137.5	130	127	122
M-303	137.5	131.5	126	121.5	138	132.5	128	123.5	138	132	126.5	123
M-323	141	131.5	126.5	118	141.5	122	118	109	141	131.5	127.5	118.5
M-353	137.5	129	117.5	110	137	129	119		137.5	129	118	111
M-403	115	122.5	117			121.5	116	109	115.5	123	119	
M-463	132	115.5	113		132	114.5	114		132.5	116	114	
Gulfstream boom												
ABM1	114.5	105.5	95	96	114	104.5	92.5	96.5	114	104.5	93	97
ABM2	137.5	130	127	121	137	129	126.5	120	136.5	128.5	126	120
ABM4	124.5	120	113	108.5	123	119.5	112.5	108	123	120	114	108
ABM5	118.5	115	111	111.5	120.5	114.5	111	111	120	114.5	111	111
Learjet												
M-1									98			
M-2												
M-3	104	103.5	104		111	104			114			
M-4	103.5	104			109	103.5			113			
M-5	112.5	113	107.5		118	111.5			118.5			
M-6	112	111	107.5		117	108			117.5			
M-7									106.5			
M-8									106.5			
M-9	119	109	106.5		117	107.5			107			
M-10	119	109	107		116.5	108			107			
M-11	118	117.5			121				121.5			
M-12	117.5	115			120.5	111.5			121			

^bBlade passage frequency (BPF).^cFaulty data.

TABLE VII.—Continued.

(d) Continued.

Microphone	Sound pressure level, dB											
	Position											
	6C				6D				6E			
	Run											
	228				227				226			
	Tone order ^b											
	BPF	2BPF	3BPF	4BPF	BPF	2BPF	3BPF	4BPF	BPF	2BPF	3BPF	4BPF
	Gulfstream fuselage											
M-123												
M-193												
M-243	128	122	112		128.5	121	113		128.5	121.5		
M-273	137	130	124	118.5	137.5	130	124	117.5	137	129	122.5	116.5
M-303	138	133.5	125.5		138	133	126		137.5	132	124	
M-323	141	133.5	126.5		141	133.5	126.5		140	133.5		
M-353	138	129			138.5	127.5			138.5	126		
M-403	123	128.5			125	129			127.5	129.5		
M-463	131				131				130.5			
Gulfstream boom												
ABM1	112.5	110			112.5	109.5			111	109		
ABM2	135.5	130	125	122.5	135.5	130	125	121.5	135	129.5	123.5	121
ABM4	124	122.5		117.5	124.5	122		117	124.5	122		
ABM5	118.5	118	117.5	116.5	117	118.5	117	116.5		118	117	117
Learjet												
M-1												
M-2												
M-3	111	105			114	106	104		114.5			
M-4	110.5	104.5			114	106.5	104.5		114	106.5		
M-5	113.5	106.5			115.5	107	107.5		116.5	108		
M-6	112	105.5			113		103.5		115	104.5		
M-7												
M-8												
M-9	112.5	109			118	108.5	102.5		114	108		
M-10	113.5	109			118	110			114	108.5		
M-11	115.5				118				117.5			
M-12	116				118				119			

^bBlade passage frequency (BPF).

TABLE VII.—Continued.

(d) Continued.

Microphone	Sound pressure level, dB											
	Position											
	6F				7B				7C			
	Run											
	225				223				222			
	Tone order ^b											
	BPF	2BPF	3BPF	4BPF	BPF	2BPF	3BPF	4BPF	BPF	2BPF	3BPF	4BPF
Gulfstream fuselage												
M-123												
M-193												
M-243	128	121			128.5	119.5	111		128.5	120	112.5	
M-273	137	129	123	117.5	138	127.5	123.5	116	137.5	128.5	124	116
M-303	137.5	133.5	125.5		138	131.5	125		138	132	126	
M-323	140	134	127		141	132	127.5		140.5	132.5	127.5	
M-353	138	127.5			138.5	126			138	127.5		
M-403	126.5	129.5			125	128			125	128.5		
M-463	130.5				130.5				131			
Gulfstream boom												
ABM1	111.5	110			113	109			113.5	109		
ABM2	135	130	124.5	121	136	129.5	126	121.5	136	129.5	126	121.5
ABM4	124.5	122			125.5	121		116.5	125	121		116
ABM5	116.5	117	117.5	116.5	117.5	116.5	118.5		118	118	118.5	
Learjet												
M-1												
M-2												
M-3	109.5								110			
M-4	110								109			
M-5	111											
M-6	111.5											
M-7												
M-8												
M-9	106	102.5			103.5				113	105.5		
M-10	107.5								114	107		
M-11												
M-12												

^bBlade passage frequency (BPF).

TABLE VII.—Continued.

(d) Continued.

Microphone	Sound pressure level, dB											
	Position											
	7D				7E							
	Run											
	221				220				224			
	Tone order ^b											
	BPF	2BPF	3BPF	4BPF	BPF	2BPF	3BPF	4BPF	BPF	2BPF	3BPF	4BPF
Gulfstream fuselage												
M-123												
M-193												
M-243	129	119.5	110.5	109	128	120			129	119	112	
M-273	137.5	127.5	122.5	116	136.5	127.5	121	114.5	138	127.5	123	116
M-303	137.5	130.5	124.5		137	131	124		138.5	131	126	
M-323	140	132.5	126		139.5	132.5	125.5		141	133	127	
M-353	138.5	125.5			137.5	126			139	126.5		
M-403	127.5	128			127.5	128			127	128		
M-463	130.5				130				131.5			
Gulfstream boom												
ABM1	112	108	102		112.5	108			112.5	108		
ABM2	135.5	128	124.5	120	135	127.5	123.5	119	136	128.5	125	121.5
ABM4	125.5	119.5			125.5	120			125	121		116
ABM5	117	116	117	116.5		116.5			117.5	118	118	116
Learjet												
M-1												
M-2												
M-3	112.5	106.5			116				116			
M-4	112	105.5			115.5	105.5			116	105	104.5	
M-5												
M-6												
M-7												
M-8												
M-9	115.5	108	104		115	105.5			113.5	107		
M-10	116	109.5			115				114.5	107		
M-11												
M-12												

^bBlade passage frequency (BPF).

TABLE VII.—Continued.

(d) Concluded.

Microphone	Sound pressure level, dB							
	Position							
	7F				7G			
	Run							
	219				218			
	Tone order ^b							
	BPF	2BPF	3BPF	4BPF	BPF	2BPF	3BPF	4BPF
Gulfstream fuselage								
M-123								
M-193								
M-243	128	120	110.5		128.5	122	112	110
M-273	137	127	121.5	113.5	137	130	124	118
M-303	137.5	131.5	124		137.5	133.5	125.5	121
M-323	140	131.5	124.5		140	133.5	126.5	
M-353	138	126			137.5	127.5		
M-403	126	128			125	129		
M-463	130				130.5			
Gulfstream boom								
ABM1	112	108			110.5	108		
ABM2	135	128.5	124	119	134	128	123	120
ABM4	125	120.5			123.5	120		
ABM5	116.5	116.5	116.5	115	117	117	117	116.5
Learjet								
M-1								
M-2								
M-3	111.5							
M-4	113							
M-5								
M-6								
M-7								
M-8								
M-9	108	103						
M-10	109.5							
M-11								
M-12								

^bBlade passage frequency (BPF).

TABLE VII.—Continued.

(e) Case 6

Microphone	Sound pressure level, dB											
	Position											
	1D				1E				1F			
	Run											
	134				133				132			
	Tone order ^b											
	BPF	2BPF	3BPF	4BPF	BPF	2BPF	3BPF	4BPF	BPF	2BPF	3BPF	4BPF
	Gulfstream fuselage											
M-123	114				113.5							
M-193	128.5				129				128.5			
M-243	137	129.5	119.5	114.5	137	129.5	118.5	113.5	137	129.5	120	117
M-273	140.5	135.5	132.5	128.5	140.5	135.5	132.5	128.5	140.5	135	133	130
M-303	143.5	140	133	128.5	143.5	140	133	128.5	143	139	133.5	129.5
M-323	145.5	140.5	127.5	122.5	145.5	140.5	124	128	145.5	140	125	128.5
M-353	144.5	137.5	128	121	145	137.5	128	121	144.5	136.5	128.5	123
M-403	125	116	109	107	124.5	116.5		107.5	133.5	114.5	114	107.5
M-463	131.5	124	120	116	131.5	125	121	116	132.5	124.5	120	117
Gulfstream boom												
ABM1	118	110	108	102	118	110	107.5	101.5	117.5	109.5	108.5	103
ABM2	141	135	127	120	141	135	128	120	141	135	128.5	122
ABM4	140	136.5	130	125.5	139.5	136.5	129.5	125.5	139.5	135.5	130.5	126.5
ABM5	131	124	120	110.5	131	123.5	120	111.5	131	124	119.5	111.5
Learjet												
M-1												
M-2												
M-3												
M-4												
M-5					106	102.5			110			
M-6	103				105.5	102.5			110			
M-7												
M-8												
M-9												
M-10												
M-11					111				112			
M-12									114			

^bBlade passage frequency (BPF).

TABLE VII.—Continued.

(e) Continued.

Microphone	Sound pressure level, dB											
	Position											
	7B				7C				7D			
	Run											
	215				214				213			
	Tone order ^b											
	BPF	2BPF	3BPF	4BPF	BPF	2BPF	3BPF	4BPF	BPF	2BPF	3BPF	4BPF
Gulfstream fuselage												
M-123												
M-193	127.5				127				127			
M-243	136	129	119	114	136	128.5	118	112	136	128	118.5	111.5
M-273	139.5	134.5	131.5	127.5	139.5	134.5	131.5	127	139	135	131	126.5
M-303	142	138.5	132	127.5	142.5	139	132	127.5	142.5	138.5	132	127.5
M-323	144.5	140	128.5	120.5	144.5	139.5	127.5	123	144.5	139	127	124.5
M-353	143.5	136	126.5	120.5	143.5	136.5	127	119	143.5	136.5	128	117
M-403	120.5	115.5	110.5		122.5	119			124.5	119	109	111
M-463	132	126.5	119.5		131	126.5	120.5		131	126	121	
Gulfstream boom												
ABM1	116.5	108	105	100	118	105	104	99.5	118.5	107	105	101
ABM2	140.5	135.5	129.5	119.5	140	135.5	128	121.5	140.5	135.5	126	123
ABM4	138.5	135.5	129	124.5	139	136.5	129.5	124	139.5	136.5	129	123.5
ABM5	129.5	120.5	120	111	129.5	114.5	120.5	114.5	131	107	119.5	114
Learjet												
M-1												
M-2												
M-3									111.5	108		
M-4									109.5	104.5		
M-5												
M-6												
M-7												
M-8												
M-9	102.5				107				116.5	109.5	107	
M-10	101.5				106				116	107	106	105
M-11												
M-12												

^bBlade passage frequency (BPF).

TABLE VII.—Continued.

(e) Concluded.

Microphone	Sound pressure level, dB											
	Position											
	7E				7F				7G			
	Run											
	212				211				210			
	Tone order ^b											
	BPF	2BPF	3BPF	4BPF	BPF	2BPF	3BPF	4BPF	BPF	2BPF	3BPF	4BPF
Gulfstream fuselage												
M-123									115			
M-193	128				128				128			
M-243	136	128	117.5	111.5	138	129	119.5	114	135.5	128	116.5	110.5
M-273	139.5	134.5	131.5	127	139.5	135	132	128	138.5	135	132	127
M-303	142.5	138.5	132	127.5	142	139	132.5	128	142.5	139	132.5	128
M-323	144.5	139.5	126	120	144	140	129	120	145	139.5	124.5	120
M-353	144	137	127	120	143.5	137	127.5	122	144	137	128.5	120
M-403	123	119	107	106	122	110.5	115	109.5	125.5	119	111	111
M-463	131.5	126.5	120		132	125	120	114.5	131.5	125	122	114
Gulfstream boom												
ABM1	117.5	105.5	105	99.5	116	110	105.5	100	117	102	102.5	97.5
ABM2	140	134.5	128.5	121	140.5	136	130	120.5	140	135	128	122
ABM4	138.5	136	129	124.5	138.5	135.5	130	124.5	138.5	136	128.5	125.5
ABM5	129.5	119.5	120	113	130	122.5	118.5	110.5	129.5	113	121	115
Learjet												
M-1												
M-2												
M-3	119	114	108	106.5	119.5	111.5			106.5			
M-4	118	113	105.5	106	120	112	103	103	105			
M-5												
M-6												
M-7												
M-8												
M-9	121	113.5	107	106	117	108.5						
M-10	121	114	104.5	105	117	108						
M-11												
M-12												

^bBlade passage frequency (BPF).

TABLE VII.—Continued.

(f) Case 7

Microphone	Sound pressure level, dB											
	Position											
	1B				1C				1D			
	Run											
	131				130				129			
	Tone order ^b											
	BPF	2BPF	3BPF	4BPF	BPF	2BPF	3BPF	4BPF	BPF	2BPF	3BPF	4BPF
Gulfstream fuselage												
M-123	113				112.5				114			
M-193	118				117.5							
M-243	129.5	123	119	113	129.5	123.5	119.5	112.5	130	125.5	118	112.5
M-273	138.5	131.5	128.5	126	138	131	128.5	126	138.5	131	128.5	126
M-303	138.5	135	131	126	138.5	134.5	130.5	125.5	138.5	135	131	125.5
M-323	140.5	135	130.5	126	140	135	130.5	126	140	135	130.5	126
M-353	138	127.5	124.5	112.5	137.5	127.5	124	111.5	138	128	124.5	111
M-403	135.5	115	112	111	136	116	113	110.5	136	117.5	113.5	112
M-463	131	114	115.5	113.5	131	114.5	114	114	131	116	114.5	114.5
Gulfstream boom												
ABM1	112.5	99	102.5	100	112.5	100.5	102.5	100	112.5	100	102.5	100
ABM2	139.5	135.5	134.5	130.5	139.5	135.5	134	130.5	139	135.5	133.5	130
ABM4	130	127	113.5	118	130	128	114.5	118	130	127.5	114	118.5
ABM5	122	120.5	110.5	113	122	120	111	112.5	122	120.5	110.5	113
Learjet												
M-1												
M-2												
M-3												
M-4												
M-5												
M-6	101				100.5				101.5	99.5		
M-7												
M-8												
M-9												
M-10												
M-11					107.5							
M-12												

^bBlade passage frequency (BPF).

TABLE VII.—Continued.

(f) Continued.

Microphone	Sound pressure level, dB											
	Position											
	1E						1F					
	Run											
	128				127				299			
	Tone order ^b											
	BPF	2BPF	3BPF	4BPF	BPF	2BPF	3BPF	4BPF	BPF	2BPF	3BPF	4BPF
Gulfstream fuselage												
M-123	114				114							
M-193	117.5				117.5				(c)			
M-243	129.5	123	119.5	112.5	129.5	122.5	118.5	112	128	121.5	118.5	112
M-273	138.5	131	128.5	126	138	131	128.5	125.5	136.5	130	128	125
M-303	138.5	135	131	126	138.5	135	130.5	125.5	136.5	134	130	125
M-323	140.5	135	130.5	126	140	135	130	125.5	139	134	129	125.5
M-353	138	128	124.5	112	138	127.5	124.5	112	136.5	127.5	123.5	112.5
M-403	136	116	113	111.5	135.5	116	112	111	133.5			
M-463	131.5	115	115.5	113	131	116	115	112.5	129.5		115.5	
Gulfstream boom												
ABM1	112	100.5	102.5	99	112.5	101	101.5	98.5	109.5	101.5	100	96
ABM2	139.5	135.5	134	130.5	139.5	135.5	134.5	130	137.5	134	133	129.5
ABM4	130	127.5	113.5	117.5	130	128.5	115	117.5	127	127	115	115.5
ABM5	122	120	110.5	112	122	120	111.5	112	119	117.5	111	113
Learjet												
M-1												
M-2												
M-3												
M-4												
M-5	107	103.5			104.5				118.5			
M-6	107.5	103	100		105.5				119			
M-7												
M-8												
M-9												
M-10												
M-11	111.5				109.5				117			
M-12	113.5								118			

^bBlade passage frequency (BPF).^cFaulty data.

TABLE VII.—Continued.

(f) Continued.

Microphone	Sound pressure level, dB											
	Position											
	1G						5C					
	Run											
	126				298				303			
	Tone order ^b											
	BPF	2BPF	3BPF	4BPF	BPF	2BPF	3BPF	4BPF	BPF	2BPF	3BPF	4BPF
Gulfstream fuselage												
M-123	115											
M-193	117				(c)				(c)			
M-243	130	122.5	119.5	112.5	128.5	121.5	118.5	111	128	122	118.5	111.5
M-273	138.5	131	128.5	126	137	129.5	128	124.5	137	130.5	127.5	126
M-303	139	135	131	126	137	133.5	130	124.5	137	134.5	130	126.5
M-323	140.5	135.5	131	126	139	133	129.5	124.5	138.5	135	130	126
M-353	138	128	124.5	112	136.5	126.5	124	111	136	128	123.5	112
M-403	136	120	115.5	113.5	133.5				133.5	120.5	115.5	114
M-463	131.5	115.5	114.5	113.5	129	116	115		130	115	116	114
Gulfstream boom												
ABM1	112.5	102	103	98	109.5	104.5	100	94	110.5	101.5	102	97
ABM2	139	135.5	133.5	130	138.5	134	133.5	126	137	135	132.5	130
ABM4	130.5	127	115	117.5	128	128	115	116	128	125	113	118.5
ABM5	121.5	120	111	113	119	116	112	114	120	120	111	113.5
Learjet												
M-1												
M-2												
M-3									108	104		
M-4									108	101.5		
M-5									111	106.5	103.5	
M-6									111	106	103.5	102
M-7												
M-8												
M-9									115	109.5	105.5	103
M-10									115.5	109	105	102.5
M-11									117			
M-12									118.5	111		

^bBlade passage frequency (BPF).^cFaulty data.

TABLE VII.—Continued.

(f) Continued.

Microphone	Sound pressure level, dB											
	Position											
	5D				5E				5F			
	Run											
	302				301				300			
	Tone order ^b											
	BPF	2BPF	3BPF	4BPF	BPF	2BPF	3BPF	4BPF	BPF	2BPF	3BPF	4BPF
Gulfstream fuselage												
M-123												
M-193	(c)				(c)				(c)			
M-243	128.5	121	120	110	128.5	122	119.5	112	128	121	119	113
M-273	137	130	128	125.5	137	130	128.5	126	136.5	130	128	124.5
M-303	137.5	134	130.5	125.5	137.5	134	130	125	136.5	133.5	130	124.5
M-323	139	135	130.5	126	139	135	130	126	138.5	133.5	129.5	124.5
M-353	136.5	128	124	111.5	136.5	127	124	111	136.5	126	123.5	112
M-403	133.5	118	114.5	112.5	134	120	115	113	134			
M-463	130	115.5	117	113.5	129.5		116		129.5	115.5	115.5	
Gulfstream boom												
ABM1	110	103	102	95	110	104	102.5	95.5	110	102.5	109.5	93
ABM2	137.5	134	133	129.5	138	134	133.5	128.5	138	134	133.5	129
ABM4	128	125	112.5	117.5	128	125.5	112	116.5	127	127.5	117	115.5
ABM5	119	119.5	110	112.5	119.5	119	110	111.5	120	116.5	112.5	113.5
Learjet												
M-1												
M-2												
M-3	108	107			113	107	103.5	103	114	105.5	104	
M-4	107	104	101.5		111	105	103		113.5	105.5	102.5	
M-5	114.5	110	107	105	118	114.5	109.5	107.5	120.5	112	108.5	103
M-6	114.5	109	106	103	117.5	113.5	110.5	107	119.5	111	104	
M-7	114.5	107	101.5	99								
M-8	115	108	104									
M-9	120	114	108.5	106.5	120.5	112.5	106		116.5	110		
M-10	120	114	109.5	105.5	120	112	105.5	103	117	110		
M-11	121	117	112		121	117			123	113.5		
M-12	122	116	111	107.5	122	116.5			124	113.5		

^bBlade passage frequency (BPF).^cFaulty data.

TABLE VII.—Continued.

(f) Continued.

Microphone	Sound pressure level, dB											
	Position											
	7B				7C				7D			
	Run											
	198				197				196			
	Tone order ^b											
	BPF	2BPF	3BPF	4BPF	BPF	2BPF	3BPF	4BPF	BPF	2BPF	3BPF	4BPF
	Gulfstream fuselage											
M-123												
M-193	116.5				116.5				117			
M-243	129	122	119.5	112	128.5	121.5	119.5	113	128.5	121.5	119	112
M-273	137.5	130	128	125.5	137.5	130.5	128.5	126	137.5	130.5	128.5	126
M-303	138	134	130.5	125.5	137.5	134	130.5	126	137.5	134	130.5	125.5
M-323	139.5	135	130.5	126	139.5	135	130	126	139.5	134	130	126
M-353	137	127.5	124.5	112	137.5	127.5	124.5	112	137.5	127.5	124	112
M-403	134.5	117	112.5	111.5	134.5	117		111	134.5			
M-463	131	113.5	115	114	131	113	115.5	114.5	130.5	113.5	114	113
Gulfstream boom												
ABM1	111.5	96.5	102	98	111.5	98	102.5	99	117.5	98	102	99
ABM2	137.5	134.5	133	130	138	134.5	133	130	138	134	133	130
ABM4	128.5	124.5	113	117.5	128.5	125.5	111	117	128	126	111.5	117
ABM5	121.5	120.5	111	112.5	121.5	120	119	111.5	121.5	120	109.5	111
Learjet												
M-1												
M-2												
M-3					103.5				109			
M-4					102				109	101		
M-5												
M-6												
M-7												
M-8												
M-9					105.5				110			
M-10					105.5				110.5			
M-11												
M-12												

^bBlade passage frequency (BPF).

TABLE VII.—Continued.

(f) Concluded.

Microphone	Sound pressure level, dB											
	Position											
	7E				7F				7G			
	Run											
	195				194				193			
	Tone order ^b											
	BPF	2BPF	3BPF	4BPF	BPF	2BPF	3BPF	4BPF	BPF	2BPF	3BPF	4BPF
Gulfstream fuselage												
M-123												
M-193	117.5				116.5							
M-243	129.5	122	119	112	128	122	118.5	112.5	129	123	118.5	112.5
M-273	138	131	128.5	126	137	130	128	125	137.5	131	128	126
M-303	138.5	134	131	126	137	133.5	130	125	138	134	130	126
M-323	139.5	135	132	127	139	134	129.5	125	139	133	130	127.5
M-353	137.5	129	123.5	115	137	127	123	112	137	127	124	111
M-403	133	120	119	114	134.5				133.5	118	115	111
M-463	131.5	113.5	116	116	130.5	116	114	111.5	131	114	113	116
Gulfstream boom												
ABM1	111	99	103	96	112	101	100.5	97	112	100	101	98
ABM2	138	135	132.5	130	138	134	133	130	138	134.5	133	130
ABM4	129.5	125	115.5	118	128	128	116.5	116	129.5	126	114.5	117.5
ABM5	120.5	121.5	111.5	112.5	121	118	112.5	113	121	121	113	113
Learjet												
M-1												
M-2												
M-3									102			
M-4	101								99.5			
M-5												
M-6												
M-7												
M-8												
M-9												
M-10									100			
M-11												
M-12												

^bBlade passage frequency (BPF).

TABLE VII.—Continued.

(g) Case 8

Microphone	Sound pressure level, dB											
	Position											
	1B				1C				1D			
	Run											
	125				124				123			
	Tone order ^b											
	BPF	2BPF	3BPF	4BPF	BPF	2BPF	3BPF	4BPF	BPF	2BPF	3BPF	4BPF
Gulfstream fuselage												
M-123	114				115				115			
M-193	117.5				118.5				118.5			
M-243	126.5	116	114.5	110	126	112.5	115.5		127.5	115	116	110
M-273	133.5	128	121.5	119	133.5	126	120.5	118	134	127.5	122.5	118.5
M-303	136.5	129.5	126	120	136.5	128.5	125	118.5	136.5	130	126.5	120.5
M-323	139	129	123.5	118.5	139	128	122.5	118	139	129.5	125	120
M-353	134	125	112.5	104	134	124.5	112.5	104	134.5	124.5	113.5	105.5
M-403	130.5	116.5	115	111	130.5		113.5	110	132		116	111.5
M-463	123	116			122	116			123.5	116		
Gulfstream boom												
ABM1	103	100.5	98	89	107.5	97.5	98.5	88	100.5	100.5	97	87.5
ABM2	138.5	132.5	131	127	138.5	132	130.5	128	138.5	132.5	132	127.5
ABM4	124	109	109.5	107.5	124.5	110.5	107.5	106.5	124		110.5	112
ABM5	117.5	121	121	117.5	119	120.5	121.5	117.5	120.5	120	121.5	117.5
Learjet												
M-1												
M-2												
M-3												
M-4												
M-5					102.5				105.5			
M-6									105			
M-7												
M-8												
M-9												
M-10												
M-11									110			
M-12									113			

^bBlade passage frequency (BPF).

TABLE VII.—Continued.

(g) Continued.

Microphone	Sound pressure level, dB											
	Position											
	1E				1F							
	Run											
	122				121				305			
	Tone order ^b											
	BPF	2BPF	3BPF	4BPF	BPF	2BPF	3BPF	4BPF	BPF	2BPF	3BPF	4BPF
Gulfstream fuselage												
M-123												
M-193	118.5				118				(c)			
M-243	126.5	114	116.5	108.5	126	114	115	107.5	125.5	115	112	
M-273	133.5	127.5	122	117.5	133.5	127	120.5	117.5	133	126.5	120	118.5
M-303	136	130	126	119	136	129	125.5	118	135.5	128	124.5	119.5
M-323	139	129.5	124.5	118.5	139	129.5	123	118	138	127.5	121.5	117.5
M-353	134	125	113	105	134	125	112	104.5	133	123	112	
M-403	132.5		117	112.5	130.5		115.5	110.5	130.5		113.5	
M-463	122.5	117	114		121.5	118.5			121	115.5		
Gulfstream boom												
ABM1	105	100.5	98.5	87.5	107.5	98	98.5	87.5	104.5	97.5	97.5	87.5
ABM2	138.5	133	131.5	127	138.5	132.5	131	127.5	137.5	131	130	127
ABM4	124	108	108	106.5	124.5	111.5	107.5	106.5	122.5	109.5	106	107
ABM5	119.5	120.5	121.5	116	117.5	121	122	116.5	117.5	119.5	120	116
Learjet												
M-1												
M-2												
M-3												
M-4												
M-5	110	103.5			106				115			
M-6	110	104	100		105.5				115			
M-7												
M-8 ^c									103.5			
M-9												
M-10												
M-11	113.5								114	111		
M-12	114								113			

^bBlade passage frequency (BPF).^cFaulty data.

TABLE VII.—Continued.

(g) Continued.

Microphone	Sound pressure level, dB											
	Position											
	1G						5C					
	Run											
	120				304				309			
	Tone order ^b											
	BPF	2BPF	3BPF	4BPF	BPF	2BPF	3BPF	4BPF	BPF	2BPF	3BPF	4BPF
Gulfstream fuselage												
M-123												
M-193	117.5				(c)				(c)			
M-243	126	114	115.5	108	127	113.5	116		126	117	111	109.5
M-273	133.5	127	120.5	117	134	126.5	123	118.5	133.5	128	119.5	118.5
M-303	136	128.5	125	118	136	129.5	126	120.5	136	129	124	119.5
M-323	139	128.5	123	117.5	138.5	129	125	119.5	138.5	128.5	121	117.5
M-353	134	124.5	112.5	104	134.5	124	114.5	105	133.5	124	111	
M-403	130	116.5	116	111	131.5		116	111.5	130		113.5	
M-463	122.5	116.5			122.5	116			121.5			
Gulfstream boom												
ABM1	107	98.5	99	87	98	97.5	94	87.5	101.5	100	96	89
ABM2	139	133	131	127.5	137	131.5	131	127	137.5	131.5	129	126
ABM4	125	113	109.5	106.5	120	111	109.5	111	122.5	103.5	106.5	107
ABM5	117.5	121	122	117	119.5	118	120	116	117.5	120	119	116
Learjet												
M-1												
M-2												
M-3									107.5			
M-4									105			
M-5									111	105		
M-6									109.5	104	102	
M-7												
M-8												
M-9									111	109.5	105.5	
M-10									111.5	109	105.5	
M-11									113.5			
M-12					110				114	111		

^bBlade passage frequency (BPF).^cFaulty data.

TABLE VII.—Continued.

(g) Continued.

Microphone	Sound pressure level, dB											
	Position											
	5D				5E				5F			
	Run											
	308				307				306			
	Tone order ^b											
	BPF	2BPF	3BPF	4BPF	BPF	2BPF	3BPF	4BPF	BPF	2BPF	3BPF	4BPF
Gulfstream fuselage												
M-123												
M-193	(c)				(c)				(c)			
M-243	125.5	113	113		125.5	114.5	110.5	109.5	126	116.5	111	110
M-273	133	126	119.5	116.5	133	126.5	119	118	133	127.5	120	119
M-303	135.5	128	124	118	135.5	118	124	118.5	135.5	128.5	124.5	120
M-323	138.5	128	121	117	138	128	120.5	117.5	138	128	122.5	118
M-353	133.5	123.5	111		133	123	110	102	133	123	112	103.5
M-403	130		114		129				130		114.5	111.5
M-463	122	115			121	116			121.5	114.5		
Gulfstream boom												
ABM1	106	97	96	87.5	105.5	97.5	96.5		101.5	99.5	96.5	87.5
ABM2	137.5	131	128.5	126	137.5	130.5	129	126	137.5	131.5	130	126
ABM4	122.5	107.5	106.5	105.5	123	111	107	106	122.5	104.5	106.5	107
ABM5	118	118.5	118.5	115.5	117	119	119	115.5	118	120	120	116.5
Learjet												
M-1												
M-2												
M-3	107.5	106	103		112	107.5	103		112.5	105.5		
M-4	106	103.5			110.5	106	103		112.5	105		
M-5	111.5	110	106	103.5	117.5	114.5	108.5	107.5	119	112	103.5	
M-6	111	110	105.5	101.5	117	114.5	107.5	106	118	108		
M-7												
M-8												
M-9	120.5	114.5	108	104	120	109.5	107		115			
M-10	120.5	114	107	104	120	109.5			115			
M-11	117.5	114.5	109.5		123.5	117.5	110.5		118.5			
M-12	118.5	115	110	107	124	116.5	108		119.5	110		

^bBlade passage frequency (BPF).^cFaulty data.

TABLE VII.—Continued.

(g) Continued.

Microphone	Sound pressure level, dB											
	Position											
	7B				7C				7D			
	Run											
	192				191				190			
	Tone order ^b											
	BPF	2BPF	3BPF	4BPF	BPF	2BPF	3BPF	4BPF	BPF	2BPF	3BPF	4BPF
Gulfstream fuselage												
M-123												
M-193									117.5			
M-243	124	116			125.5	117.5	111	108	125.5	115	113.5	107.5
M-273	131.5	127.5	118	118.5	133	128.5	121.5	118.5	132.5	128	121.5	117.5
M-303	134	128	123.5	118	134.5	129.5	125.5	120	135	130	125.5	119
M-323	136	129	122.5	114.5	136	129	124	118	136.5	129.5	126.5	121
M-353	131.5	123	108.5		133	122	114		133	124.5	112	104
M-403	128.5	117	113		131.5		116.5	110.5	131		114.5	110
M-463	120.5	115			121.5				122.5			
Gulfstream boom												
ABM1	103.5	100	97	88	96.5	104	87	87.5	99	101	95.5	88
ABM2	137.5	133	130	127.5	137.5	133.5	131.5	126.5	136.5	132	130	125.5
ABM4	124.5	117.5	110.5	103.5	124	115	114.5	113	122		110	109
ABM5	115.5	121	120	116	119	121	118.5	114	118	120	120	115
Learjet												
M-1												
M-2												
M-3					103.5				110.5	104		
M-4					102				110	102		
M-5												
M-6												
M-7												
M-8												
M-9					106	102			118.5	110.5	105	101.5
M-10					105.5	101			118	110.5	105	102
M-11												
M-12												

^bBlade passage frequency (BPF).

TABLE VII.—Continued.

(g) Concluded.

Microphone	Sound pressure level, dB											
	Position											
	7E				7F				7G			
	Run											
	189				188				187			
	Tone order ^b											
	BPF	2BPF	3BPF	4BPF	BPF	2BPF	3BPF	4BPF	BPF	2BPF	3BPF	4BPF
	Gulfstream fuselage											
M-123												
M-193	118				118.5							
M-243	127	114.5	115		125.5	111.5	114.5	109	125	113.5	110	108
M-273	133.5	128	123.5	119	133	126	121	118	132.5	124.5	118.5	116.5
M-303	135.5	130.5	126	120	135.5	128.5	124.5	118.5	135	126.5	123.5	117
M-323	137.5	129.5	127.5	122.5	137.5	130	126	120	137	125	115.5	111
M-353	135	124.5	114	104.5	133.5	124.5	111.5	106	132	122	109.5	101
M-403	131	114.5	116	110.5	130		114.5	111	128			
M-463	123.5	114			122.5	115.5			120	116		
Gulfstream boom												
ABM1	96	99.5	93	98	105	98	97	87	107.5	95.5	97.5	
ABM2	136.5	132	130.5	125.5	136.5	131	129	125	137.5	130.5	128.5	126
ABM4	120.5	114	113	110	122	106	104.5	105.5	123.5	113	110	
ABM5	120	119.5	119.5	115	115.5	119.5	119.5	115.5	115.5	119.5	119.5	117.5
Learjet												
M-1												
M-2												
M-3	111	106.5			108.5	102						
M-4	110.5	106	103.5	100.5	108.5	99.5			100			
M-5												
M-6												
M-7												
M-8												
M-9	117				105				102			
M-10	117				105				103.5	99		
M-11												
M-12												

^bBlade passage frequency (BPF).

TABLE VIII.—SOUND PRESSURE LEVEL
CORRECTIONS FOR GULFSTREAM
BOOM MICROPHONES

[Method of ref. 19: decibel subtraction from measured data to obtain free field value. Subtract 6 dB from all Gulfstream fuselage measurements for free field values.]

Gulfstream boom microphone	Change in sound pressure level, dB			
	Tone order			
	BPF	2BPF	3BPF	4BPF
ABM1	0	1	1	1
ABM2	1	2	2	3
ABM3	↓	2	3	4
ABM4		2	4	5
ABM5	↓	3	5	5

TABLE IX.—SOUND PRESSURE LEVEL CORRECTIONS
FOR LEARJET MICROPHONE INSTALLATION

[Method of ref. 19: decibel subtraction from measured data to obtain free field value.]

(a) BPF tone

Azimuthal angle, ^a deg	Change in sound pressure level, dB					
	Nose microphone			Wingtip microphone		Cabin top
	Right side	Left side	Top	Right side	Left side	
90 R	(b)	5	1	(b)	5	2
60 R	(b)	4	3	(b)	4	5
30 R	(b)	3	4	(b)	3	5
0	1	1	5	1	1	6
30 L	3	(b)	4	3	(b)	5
60 L	4	(b)	3	4	(b)	5
90 L	5	(b)	1	5	(b)	2

(b) 2BPF tone

Change in sound pressure level, dB						
Azimuthal angle, ^a deg	Nose microphone			Wingtip microphone		Cabin top
	Right side	Left side	Top	Right side	Left side	
90 R	(b)	6	2	(b)	6	3
60 R	(b)	5	4	(b)	5	5
30 R	(b)	4	5	(b)	4	6
0	2	2	6	2	2	6
30 L	4	(b)	5	4	(b)	6
60 L	5	(b)	4	5	(b)	5
90 L	6	(b)	2	6	(b)	3

(c) 3BPF tone

Change in sound pressure level, dB						
Azimuthal angle, ^a deg	Nose microphone			Wingtip microphone		Cabin top
	Right side	Left side	Top	Right side	Left side	
90 R	(b)	6	2	(b)	6	3
60 R	(b)	5	5	(b)	5	5
30 R	(b)	5	5	(b)	5	6
0	2	2	6	2	2	6
30 L	5	(b)	5	5	(b)	6
60 L	5	(b)	5	5	(b)	5
90 L	6	(b)	2	6	(b)	3

(d) 4BPF tone

Change in sound pressure level, dB						
Azimuthal angle, ^a deg	Nose microphone			Wingtip microphone		Cabin top
	Right side	Left side	Top	Right side	Left side	
90 R	(b)	6	3	(b)	6	3
60 R	(b)	6	5	(b)	6	5
30 R	(b)	5	6	(b)	5	6
0	3	3	6	3	3	6
30 L	5	(b)	6	5	(b)	6
60 L	6	(b)	5	6	(b)	5
90 L	6	(b)	3	6	(b)	3

^aMeasured left (L) or right (R) of center.

^bNot applicable.

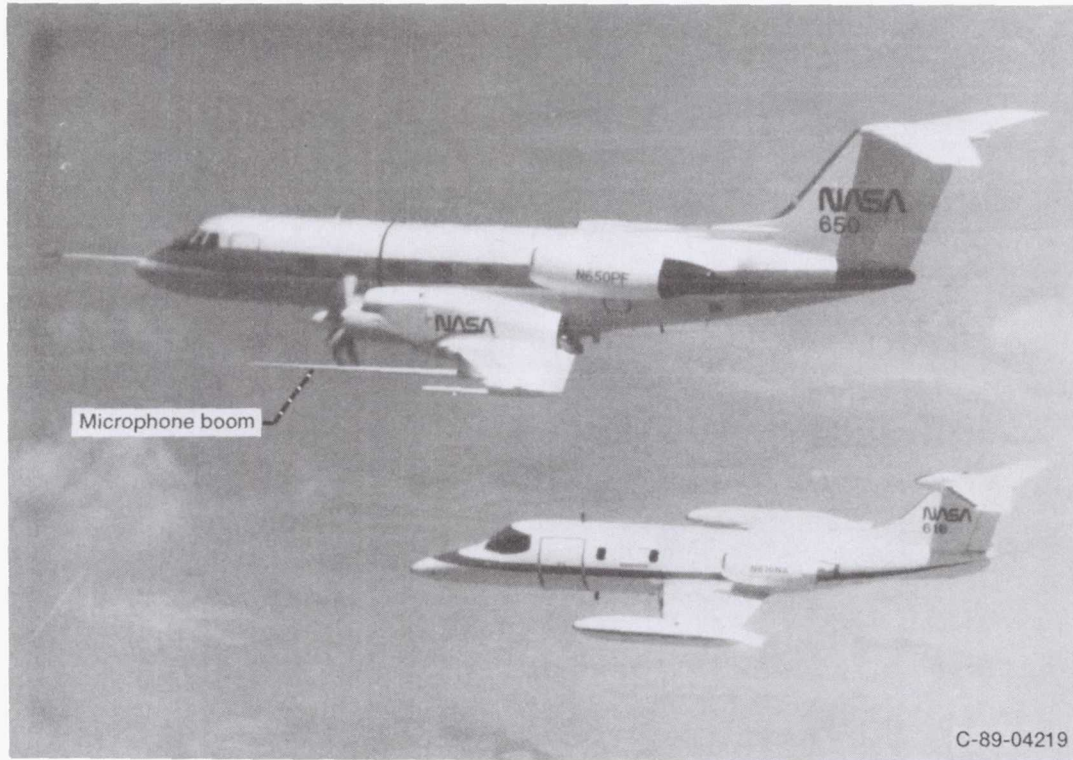

Figure 1.—In-flight photograph of Gulfstream II and Learjet aircraft.

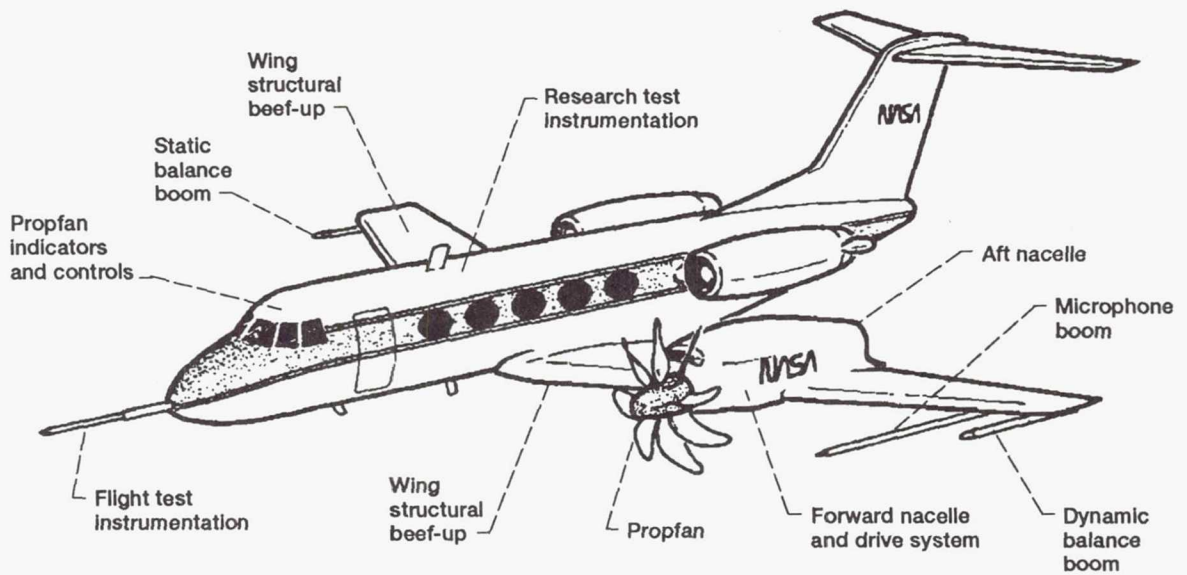

Figure 2.—Modifications of Gulfstream II aircraft to PTA configuration.

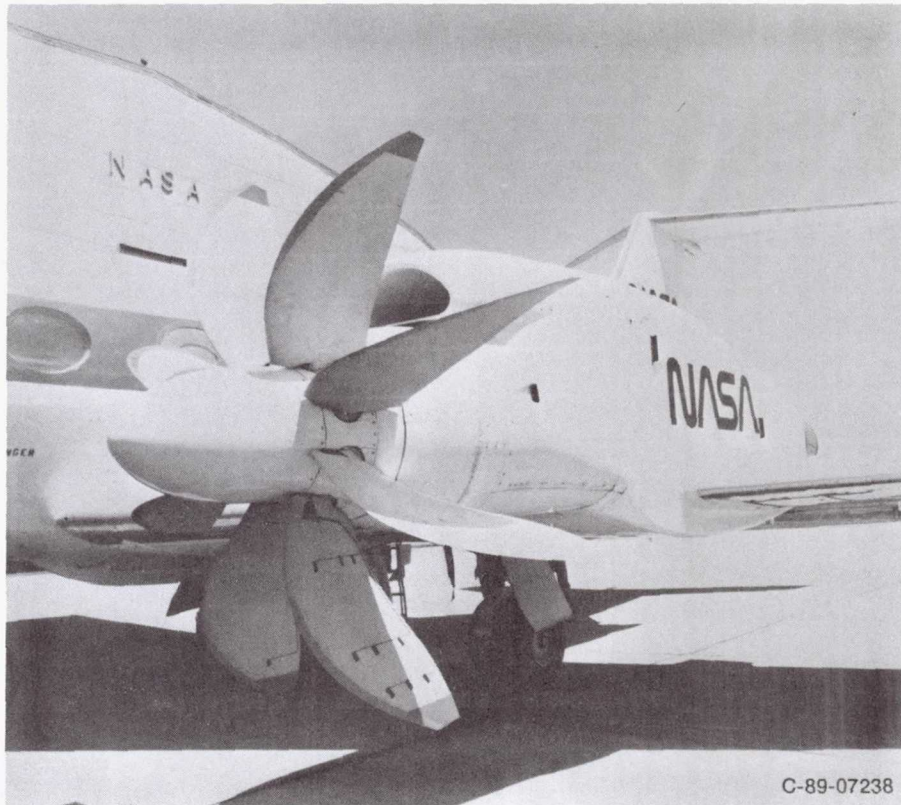

Figure 3.—SR-7L propeller installed on Gulfstream II aircraft.

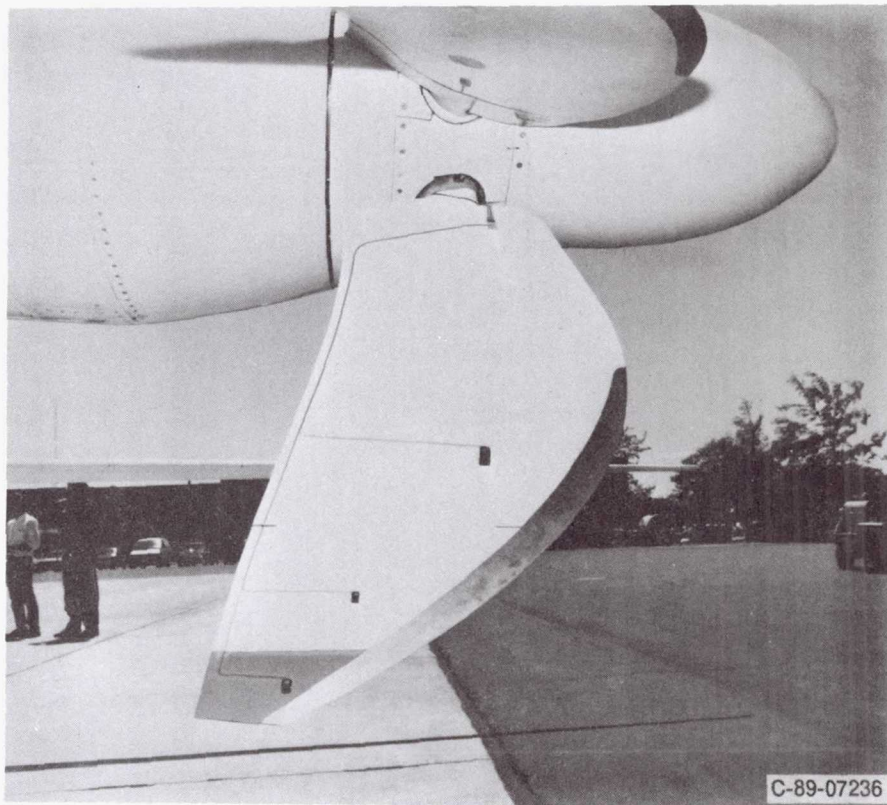

Figure 4.—Side view of SR-7L propeller.

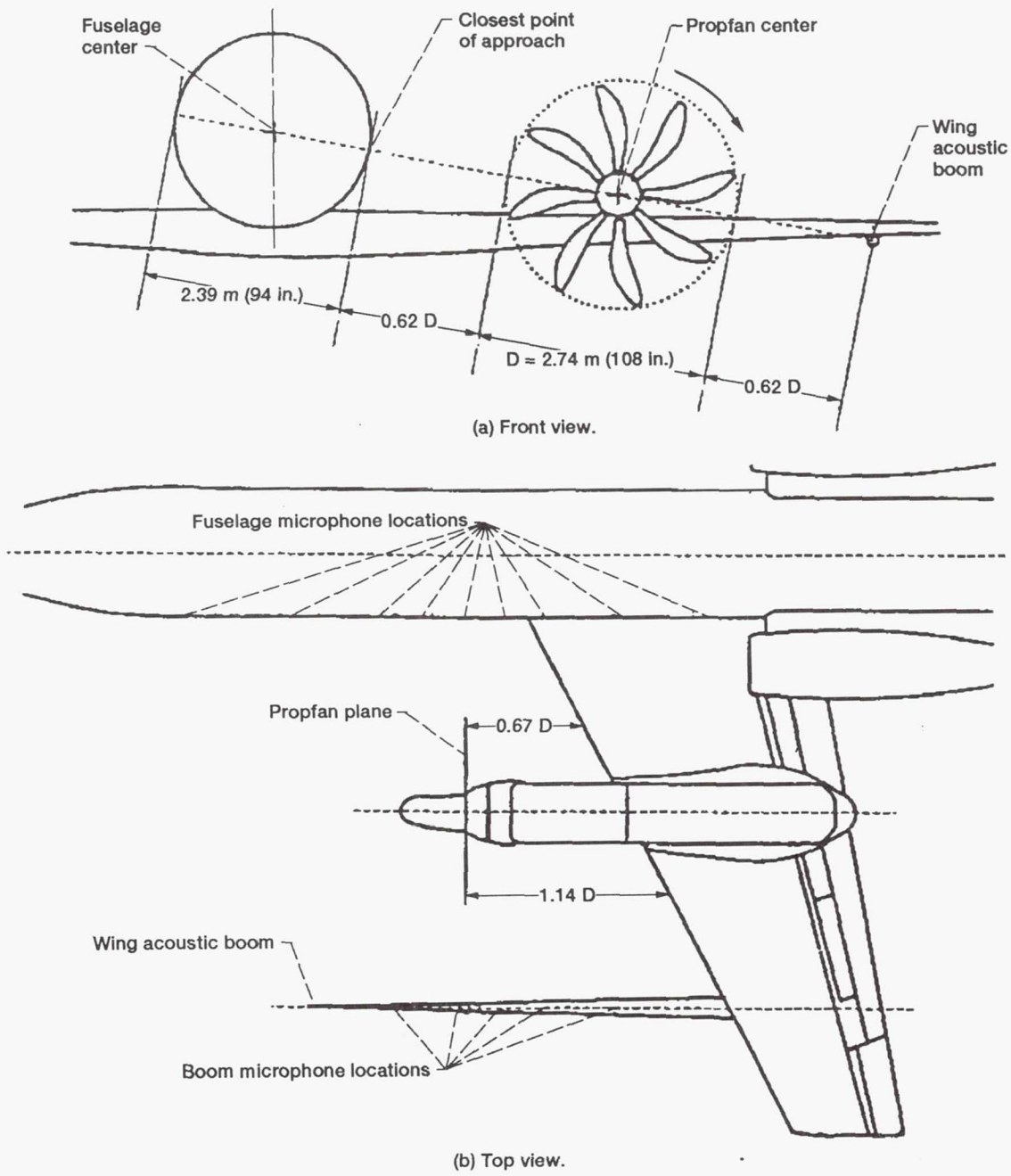

Figure 5.—PTA propeller installation and microphone locations.



Figure 6.—Learjet wingtip microphone installation.

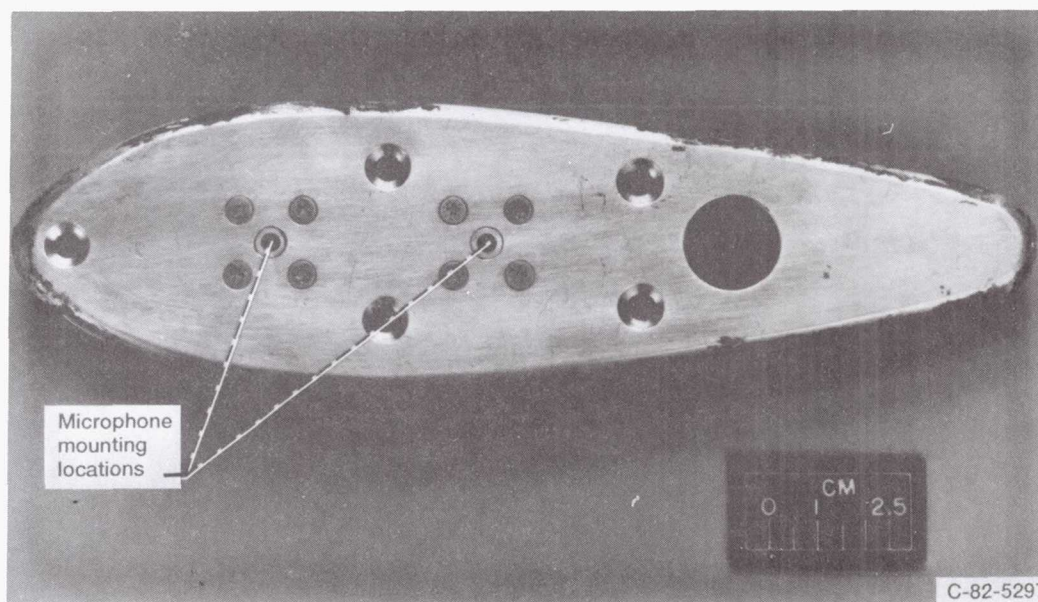
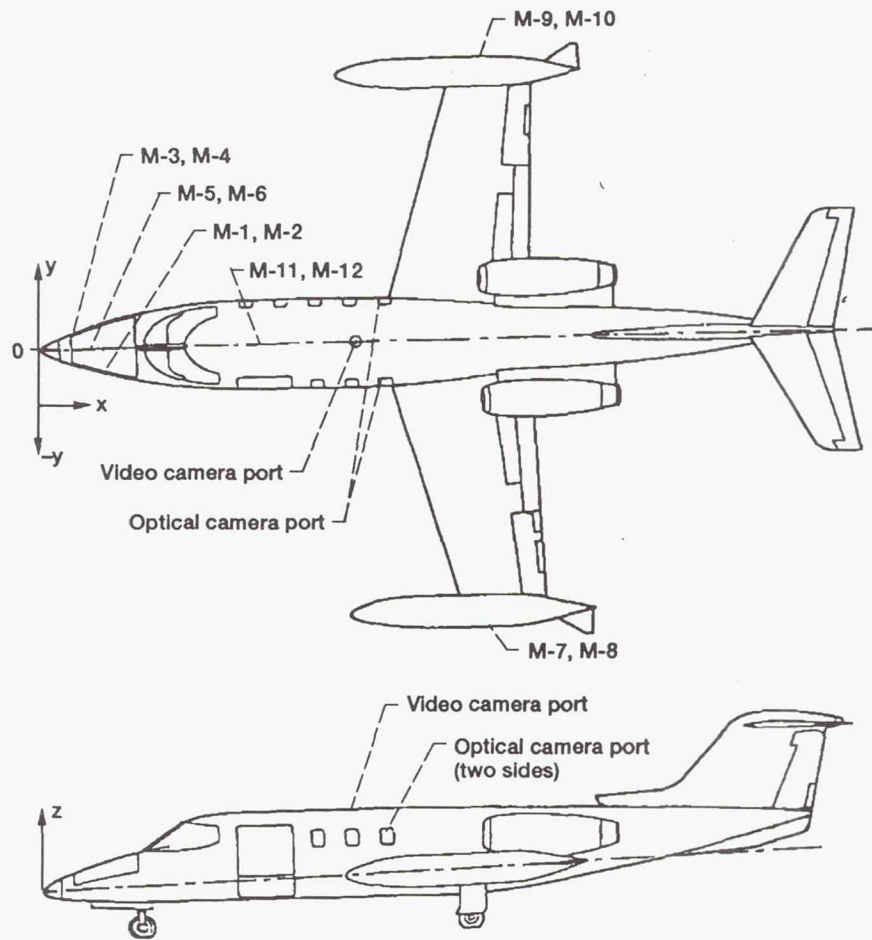

Figure 7.—Wingtip microphone mounting plate.



Figure 8.—Learjet nose microphone installation.



(a) Aircraft plan view.

Instrumentation	Coordinates					
	x		y		z	
	m	ft	m	ft	m	ft
Video camera port	4.6	15.2	0	0	1.5	4.9
Left optical camera port	5.6	18.3	-7	-2.2	.8	2.5
Right optical camera port	5.6	18.3	.7	2.2	.8	2.5
Microphones						
^a M-1, M-2	.5	1.8	-.2	-.8	0	0
^a M-3, M-4	0	1.8	.2	.8	0	0
M-5, M-6	.7	2.3	0	0	.3	1.0
M-7, M-8	7.0	23.0	-5.4	-17.6	.2	.5
M-9, M-10	7.0	23.0	5.4	17.6	.2	.5
M-11, M-12	3.7	12.2	0	0	1.5	4.9

^aNormal incidence to nose side microphones was about 30° below horizontal.

(b) Instrumentation coordinates.

Figure 9.—Learjet instrumentation locations.

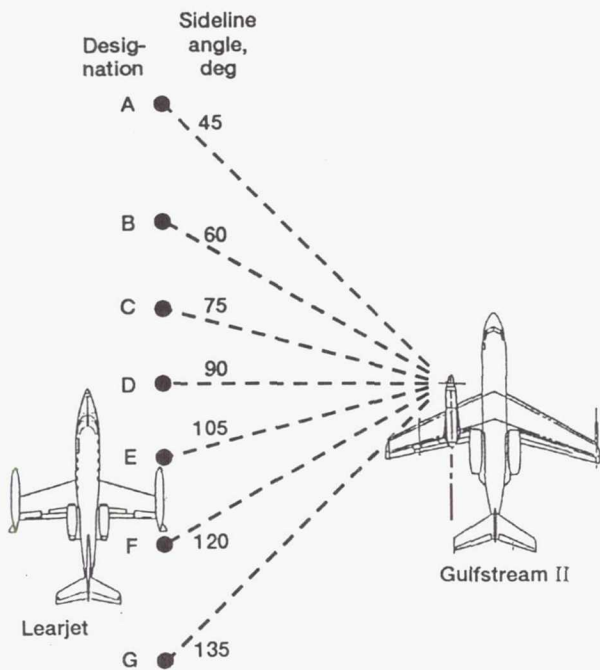

(a) Sideline angle relative to propeller upstream axis.

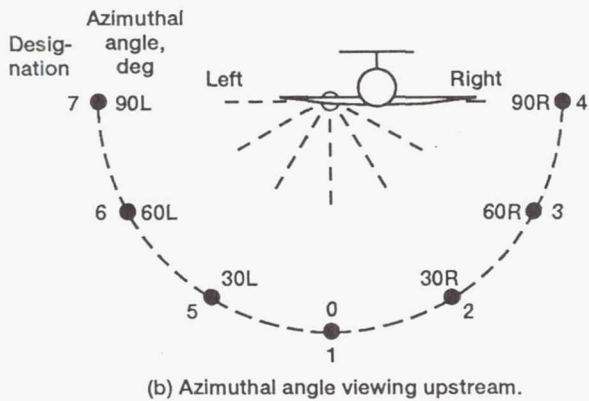

(b) Azimuthal angle viewing upstream.

Figure 10.—Position code for PTA-Learjet station-keeping data. (Example: position "5E" would nominally be azimuthally 30° left from below the propeller, and at a sideline angle of 105°).

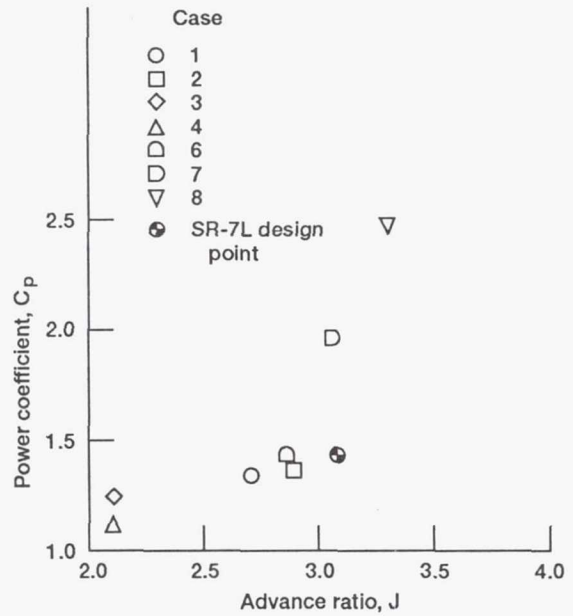

Figure 11.—Propeller operating map.

Propfan inflow angle =
 Aircraft angle of attack
 + Upwash angle
 + Propfan nacelle tilt angle

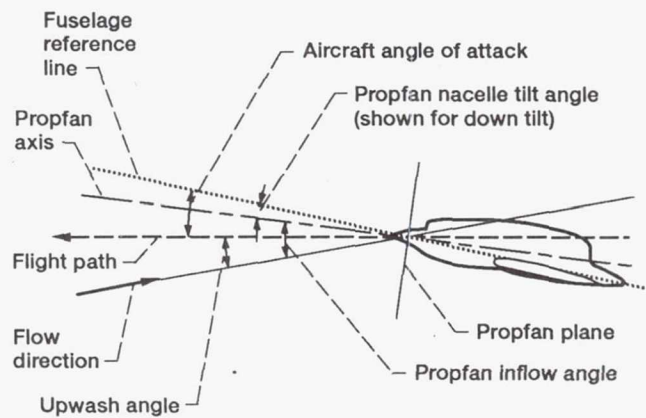

Figure 12.—Propeller installation and flow angles.

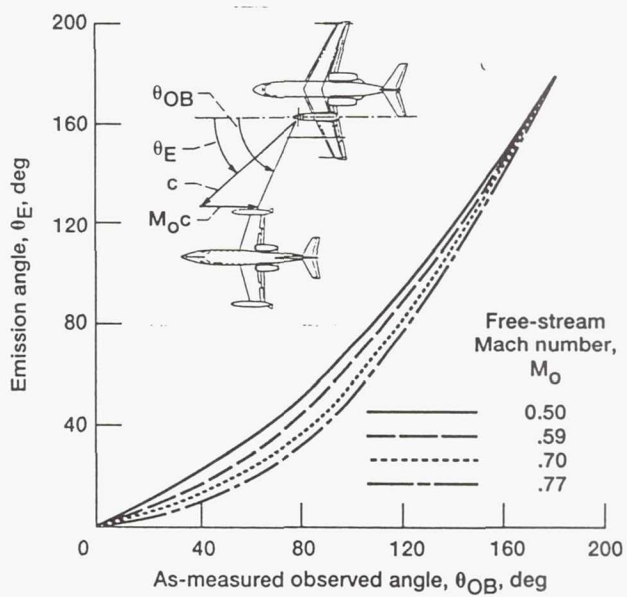

Figure 13.—Relationship between observed and emission angles. $\theta_E = \theta_{OB} - \sin^{-1}(M_0 \sin \theta_{OB})$, where c is the local speed of sound.

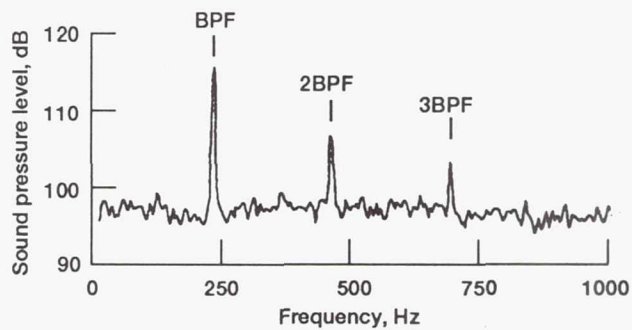

Figure 14.—Representative spectrum of PTA propeller noise for case 1 conditions. As-measured by Learjet nose microphone along a 54-m (178-ft) sideline; azimuthal location, 90° L; sideline angle, 118° ; bandwidth, 4 Hz.

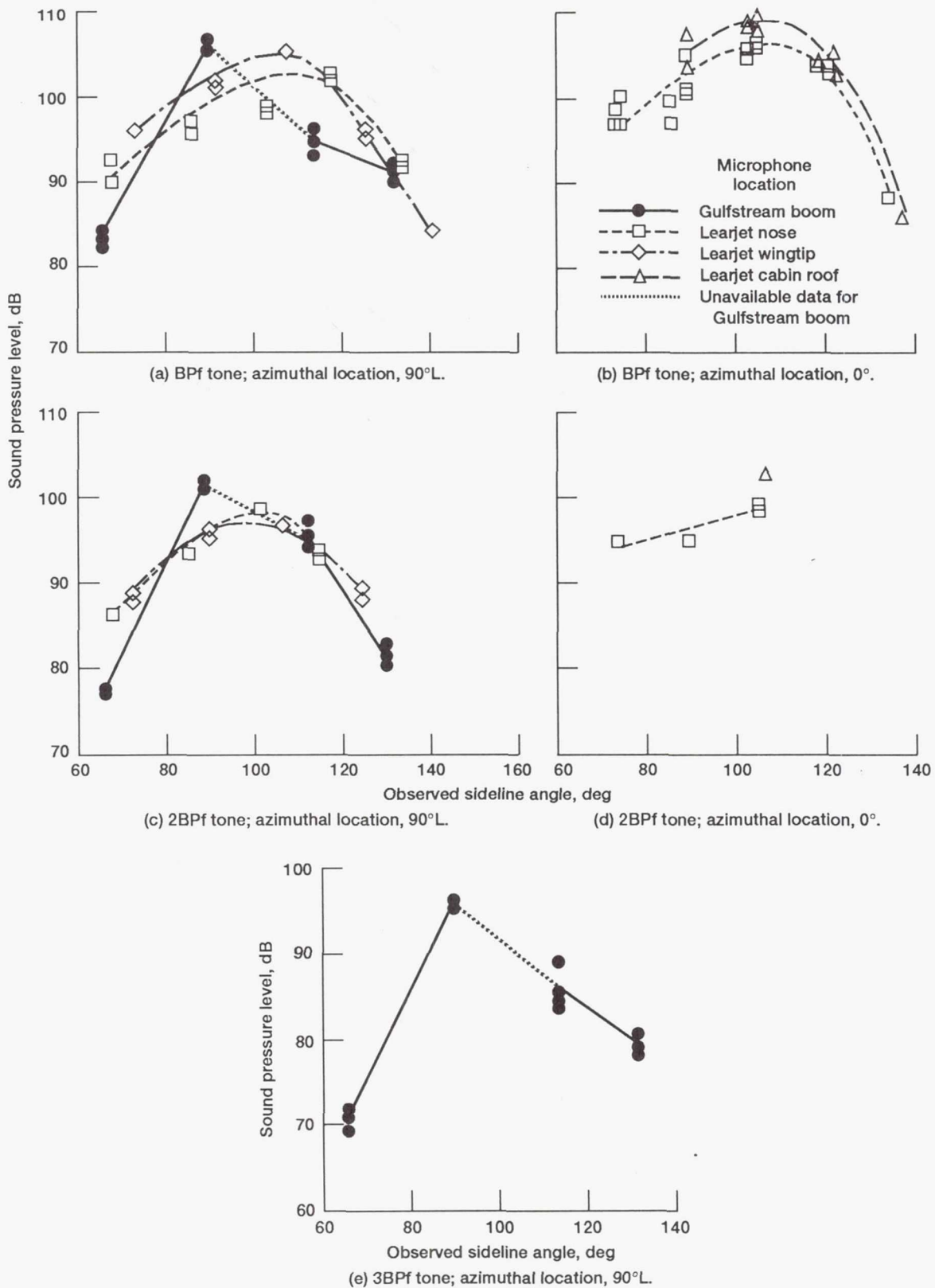

Figure 15.—PTA aircraft sideline directivity for case 1 conditions. Mach 0.70; altitude, 10 668 m (35 000 ft); data adjusted to 152-m (550-ft) free field conditions.

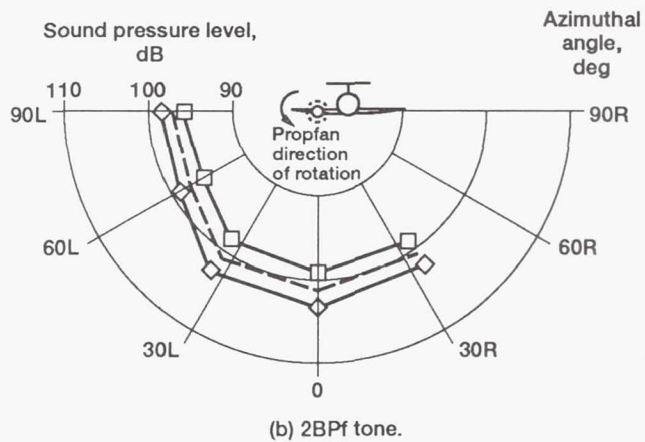
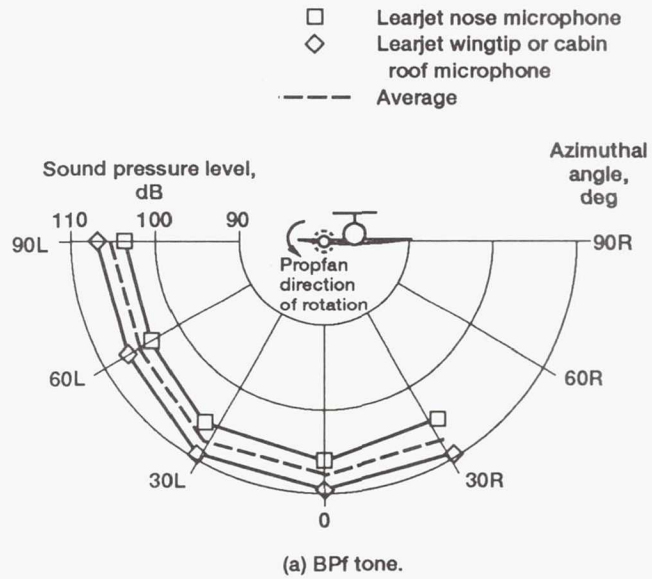

Figure 16.—PTA aircraft azimuthal directivity viewing upstream for case 1 conditions. Mach 0.70; altitude, 10 668 m (35 000 ft); data adjusted to 152-m (500-ft) free field conditions. (Wingtip microphone used at 60° and 90°; cabin roof microphone used at 0° and 30°.)

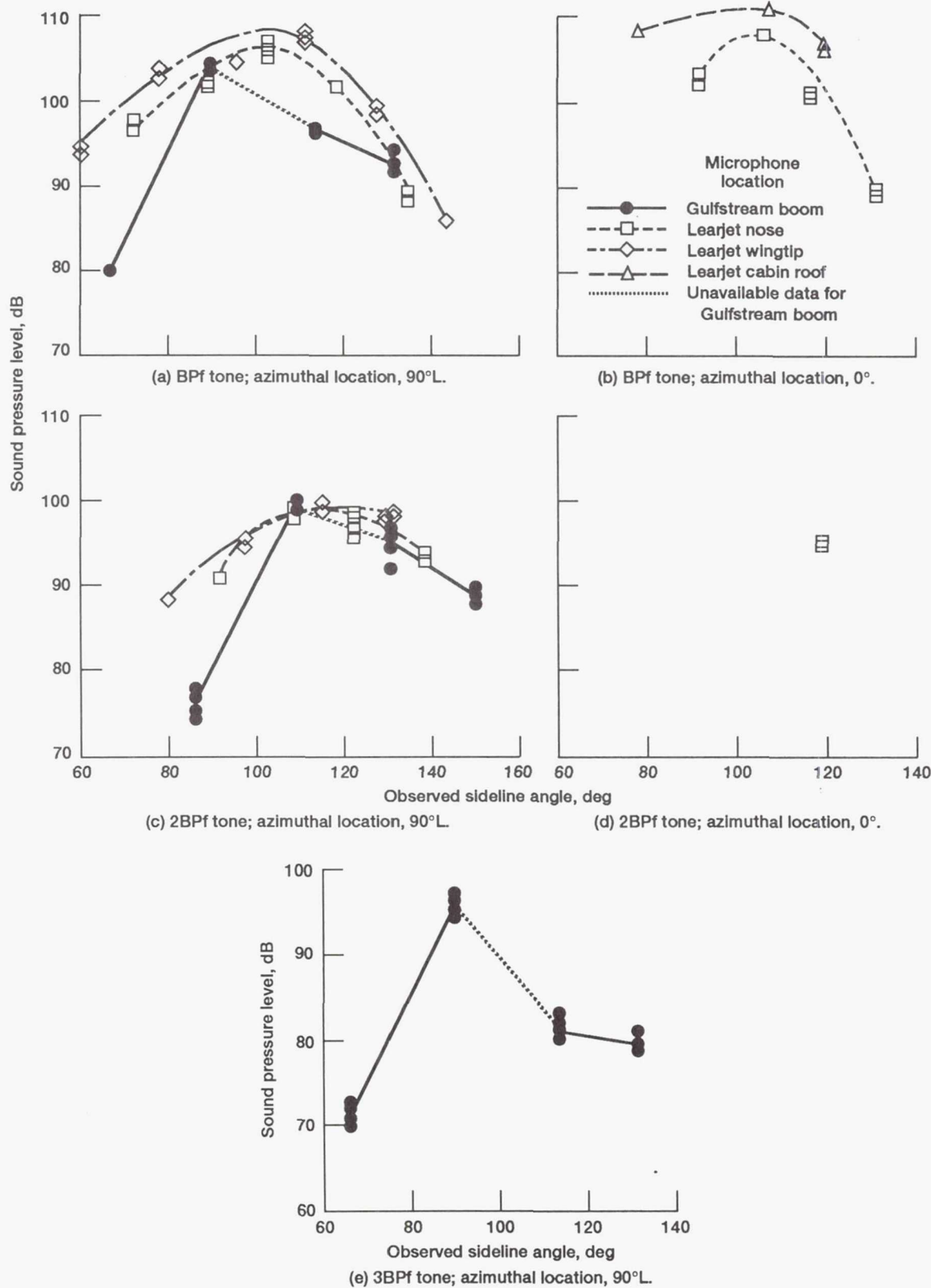

Figure 17.—PTA aircraft sideline directivity for case 2 conditions. Mach 0.70; altitude, 6096 m (20 000 ft); data adjusted to 152-m (550-ft) free field conditions.

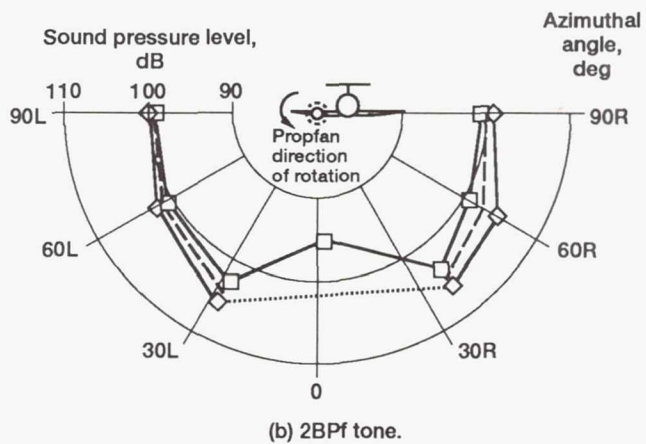
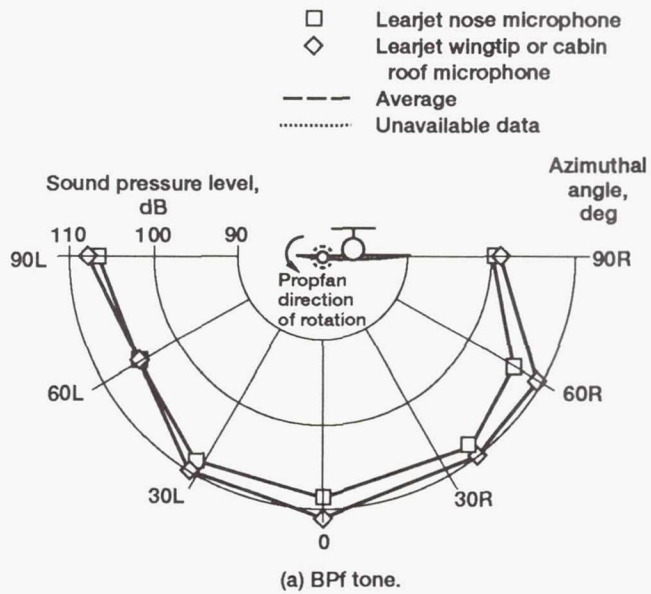

Figure 18.—PTA aircraft azimuthal directivity viewing upstream for case 2 conditions. Mach 0.70; altitude, 6096 m (20 000 ft); data adjusted to 152-m (500-ft) free field conditions.

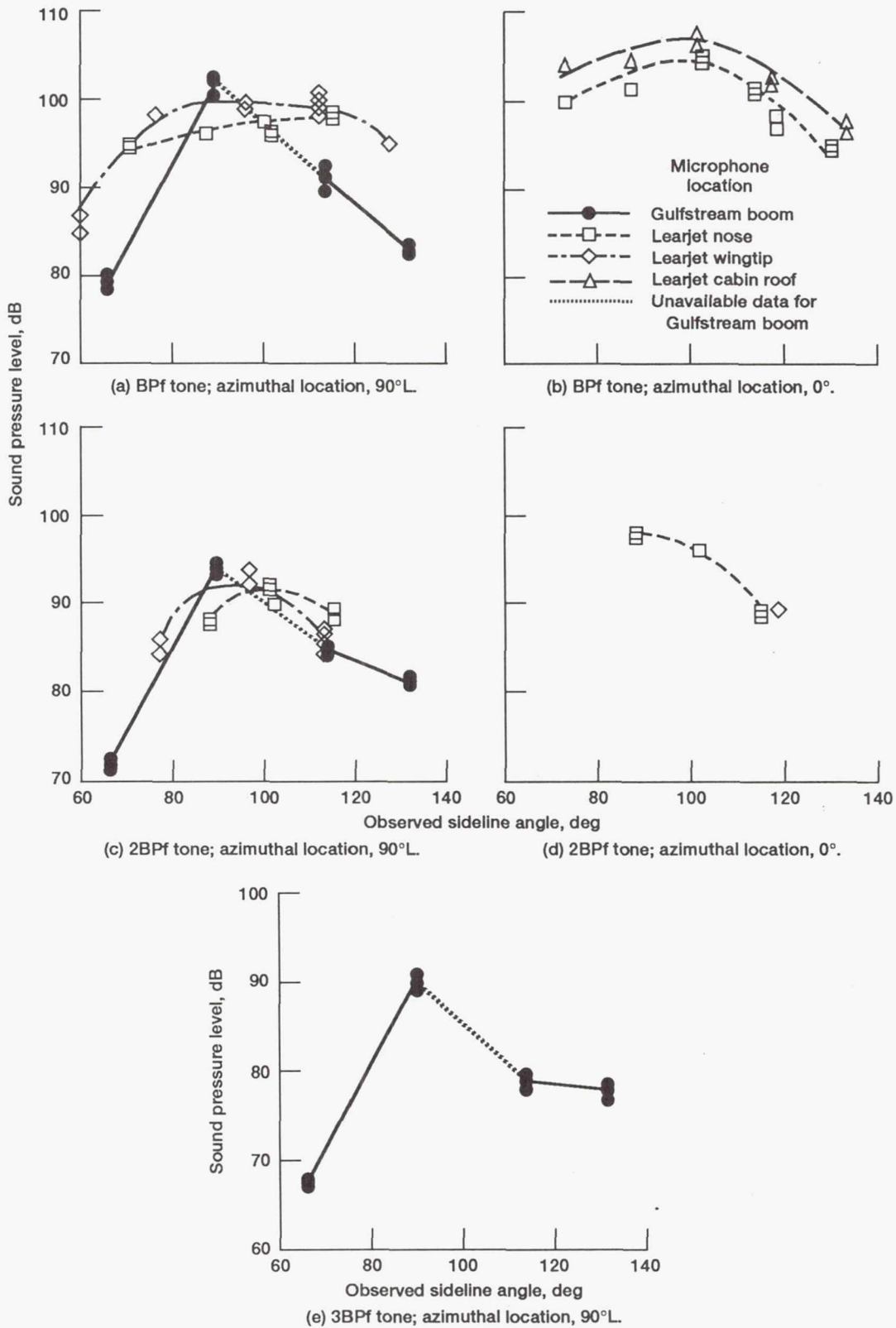

Figure 19.—PTA aircraft sideline directivity for case 3 conditions. Mach 0.50; altitude, 6096 m (20 000 ft); data adjusted to 152-m (550-ft) free field conditions.

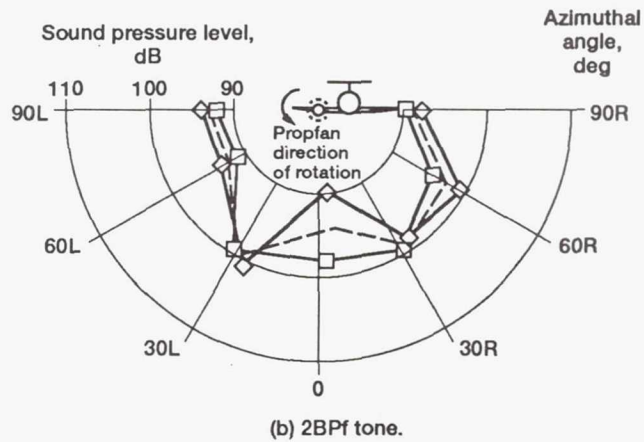
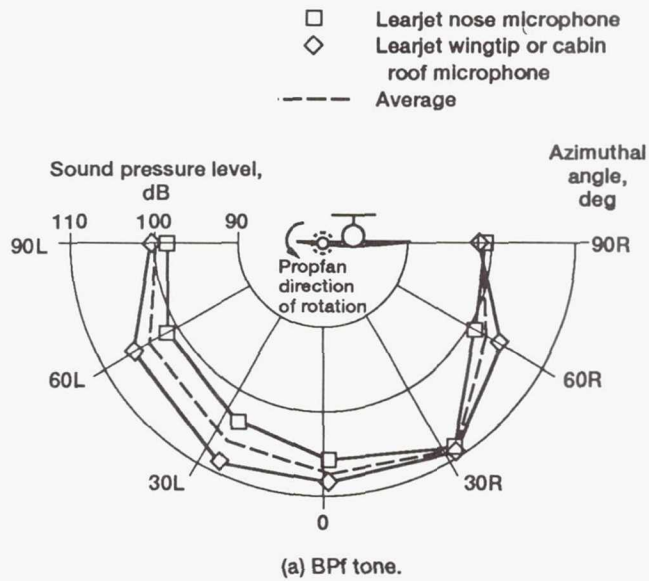

Figure 20.—PTA aircraft azimuthal directivity viewing upstream for case 3 conditions. Mach 0.50; altitude, 6096 m (20 000 ft); data adjusted to 152-m (500-ft) free field conditions.

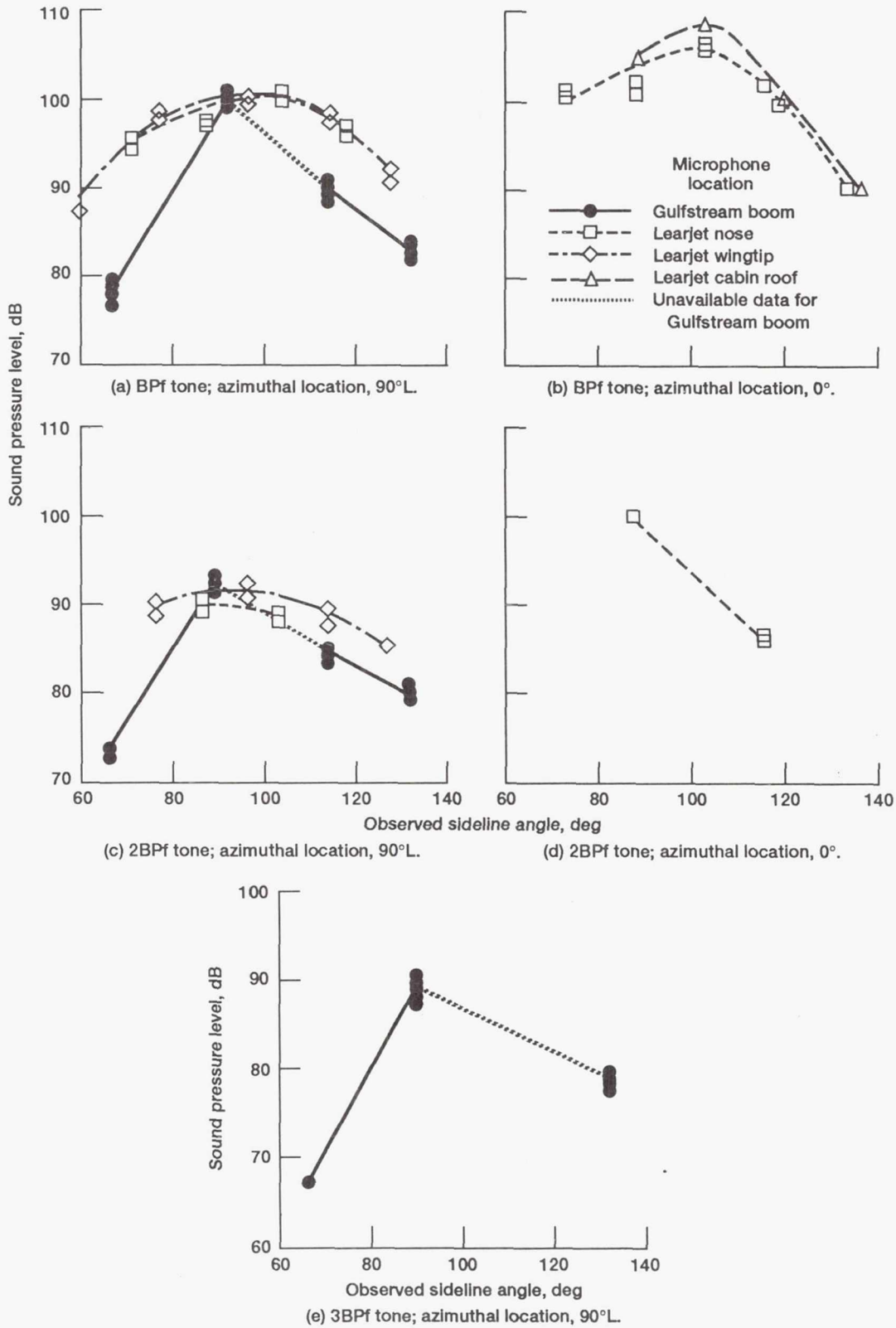
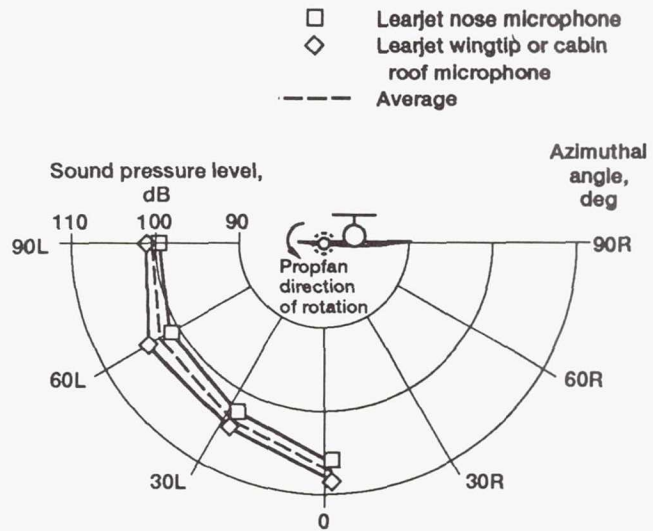
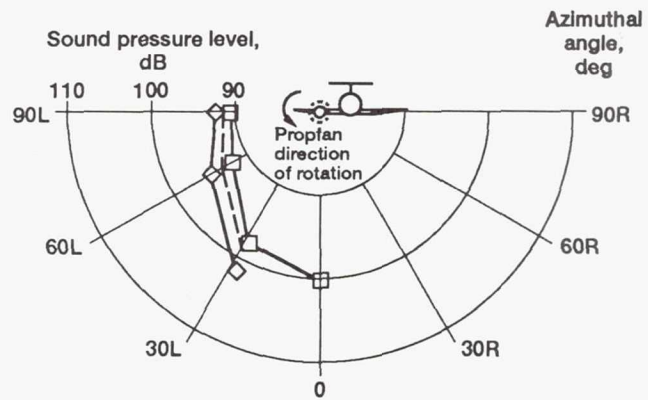

Figure 21.—PTA aircraft sideline directivity for case 4 conditions. Mach 0.59; altitude, 4267 m (14 000 ft); data adjusted to 152-m (550-ft) free field conditions.



(a) BPf tone.



(b) 2BPf tone.

Figure 22.—PTA aircraft azimuthal directivity viewing upstream for case 4 conditions. Mach 0.59; altitude, 4267 m (14 000 ft); data adjusted to 152-m (500-ft) free field conditions.

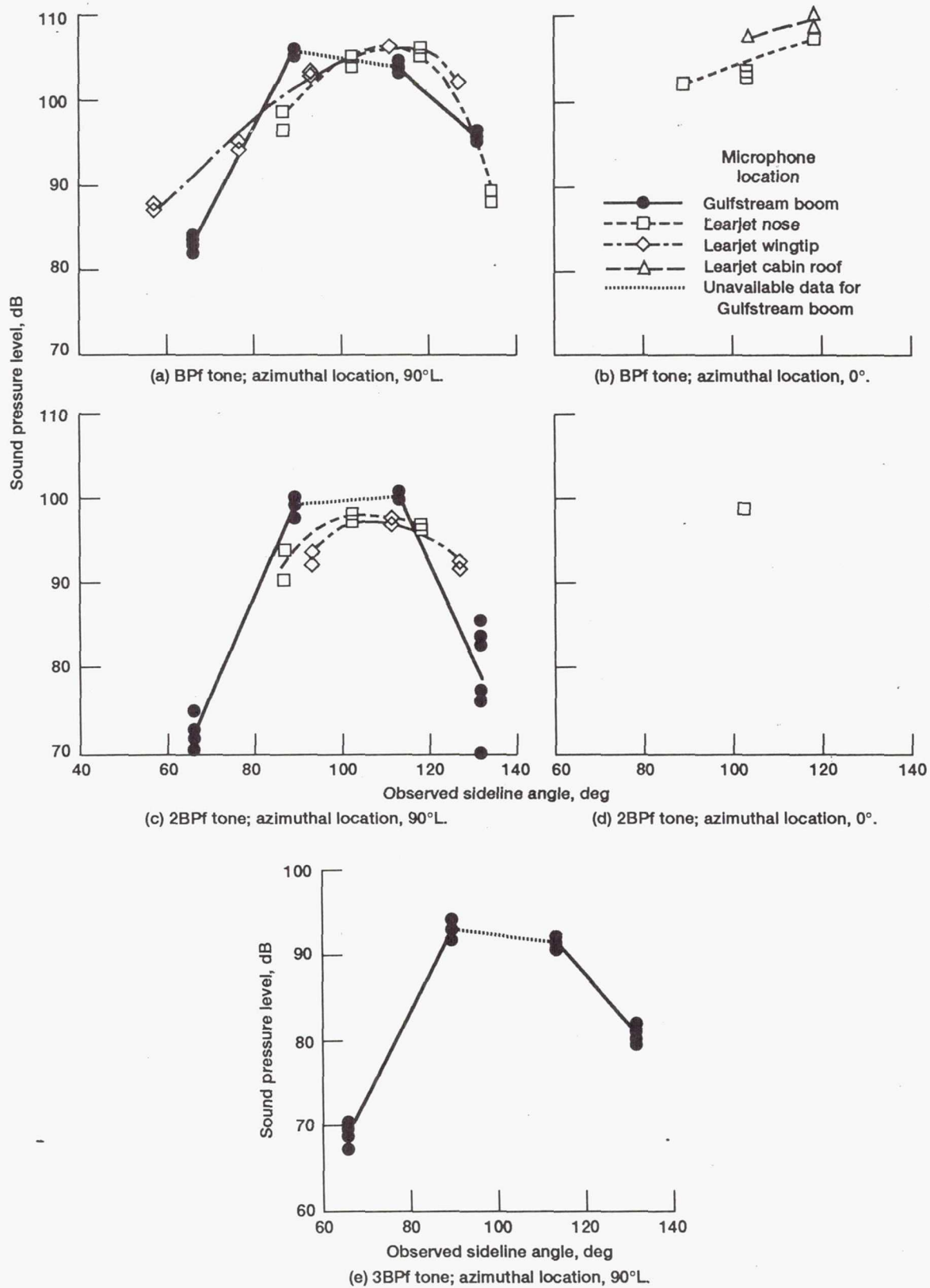
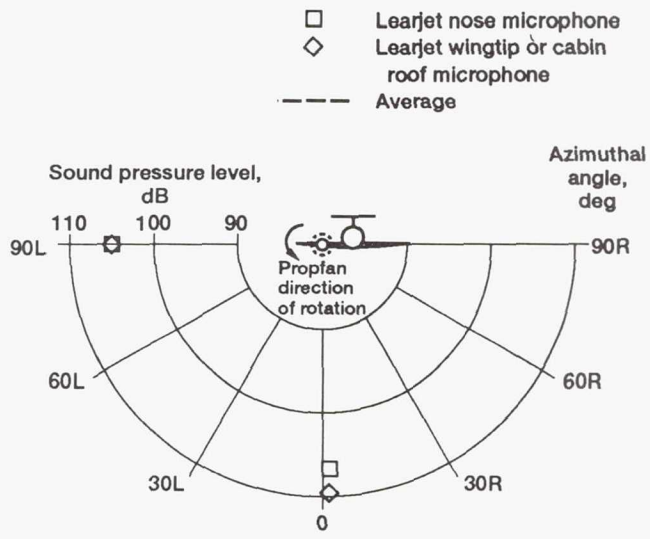
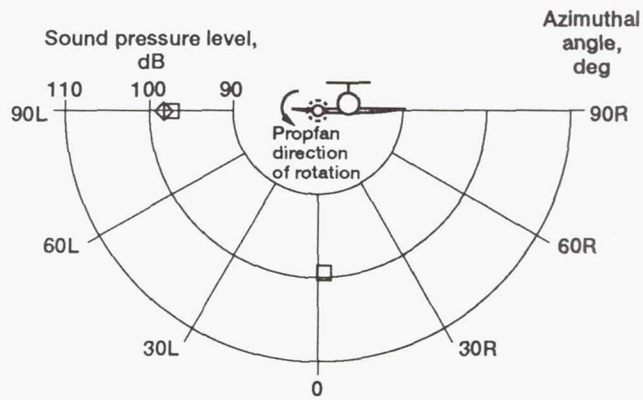

Figure 23.—PTA aircraft sideline directivity for case 6 conditions. Mach 0.77; altitude, 10 668 m (35 000 ft); data adjusted to 152-m (550-ft) free field conditions.



(a) BPF tone.



(b) 2BPF tone.

Figure 24.—PTA aircraft azimuthal directivity viewing upstream for case 6 conditions. Mach 0.77; altitude, 10 668 m (35 000 ft); data adjusted to 152-m (500-ft) free field conditions.

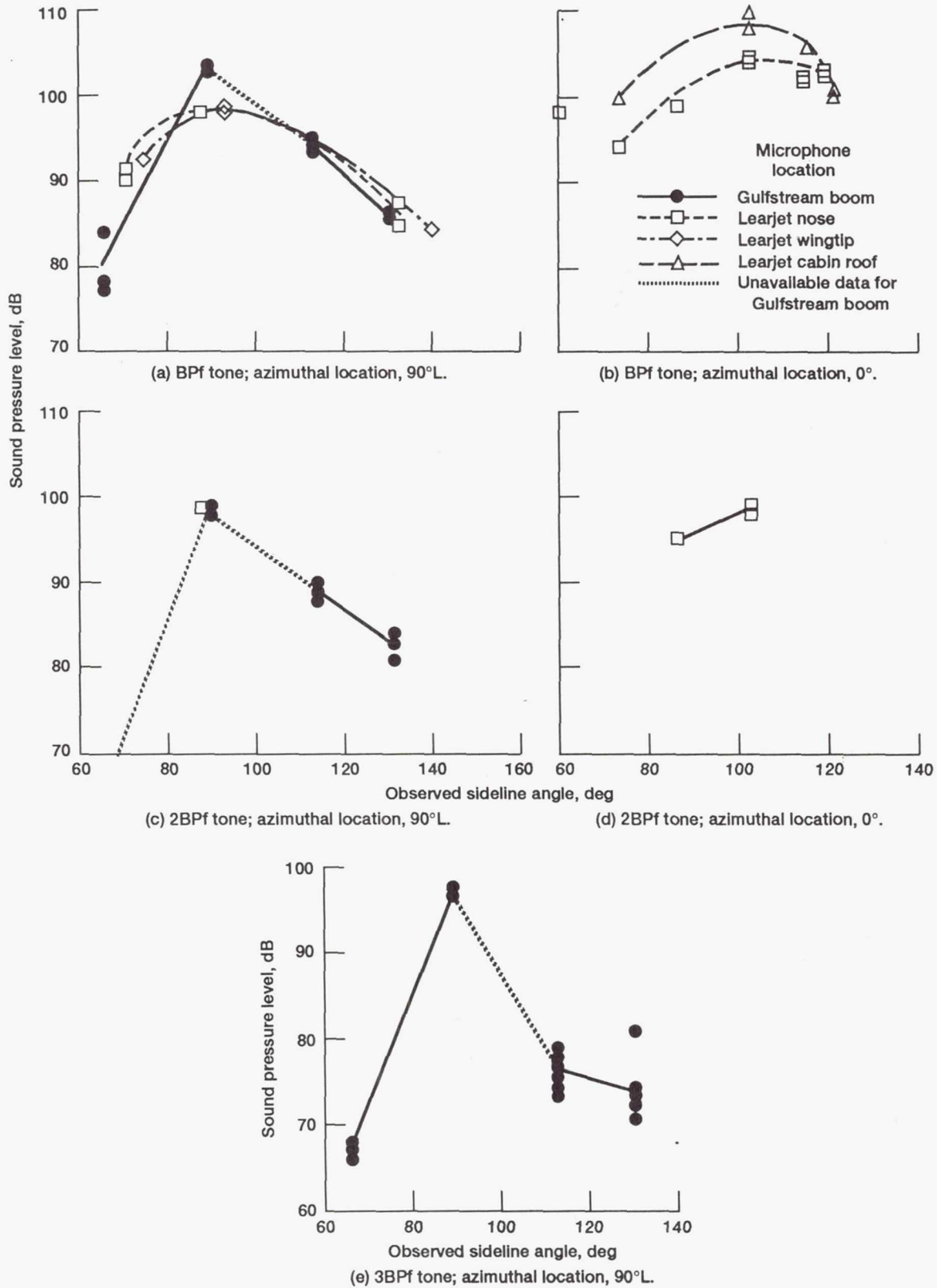
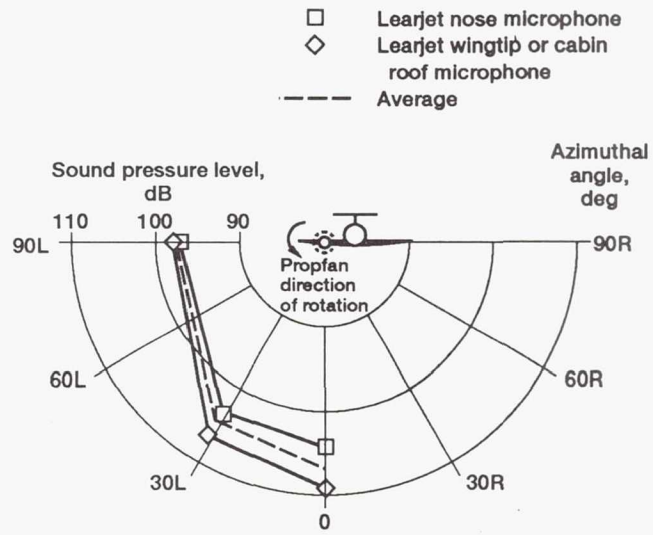
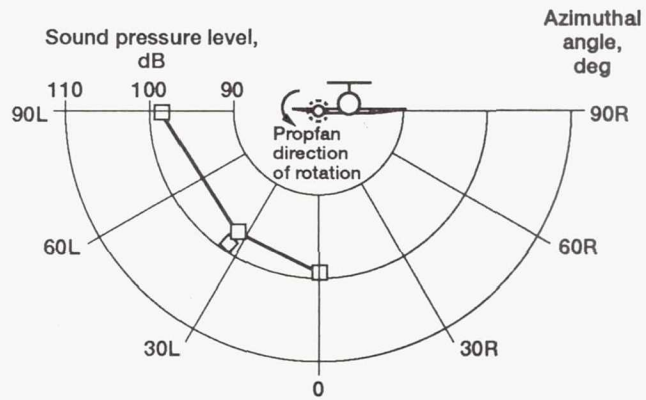

Figure 25.—PTA aircraft sideline directivity for case 7 conditions. Mach 0.70; altitude, 10 668 m (35 000 ft); data adjusted to 152-m (550-ft) free field conditions.



(a) BPF tone.



(b) 2BPF tone.

Figure 26.—PTA aircraft azimuthal directivity viewing upstream for case 7 conditions. Mach 0.70; altitude, 10 668 m (35 000 ft); data adjusted to 152-m (500-ft) free field conditions.

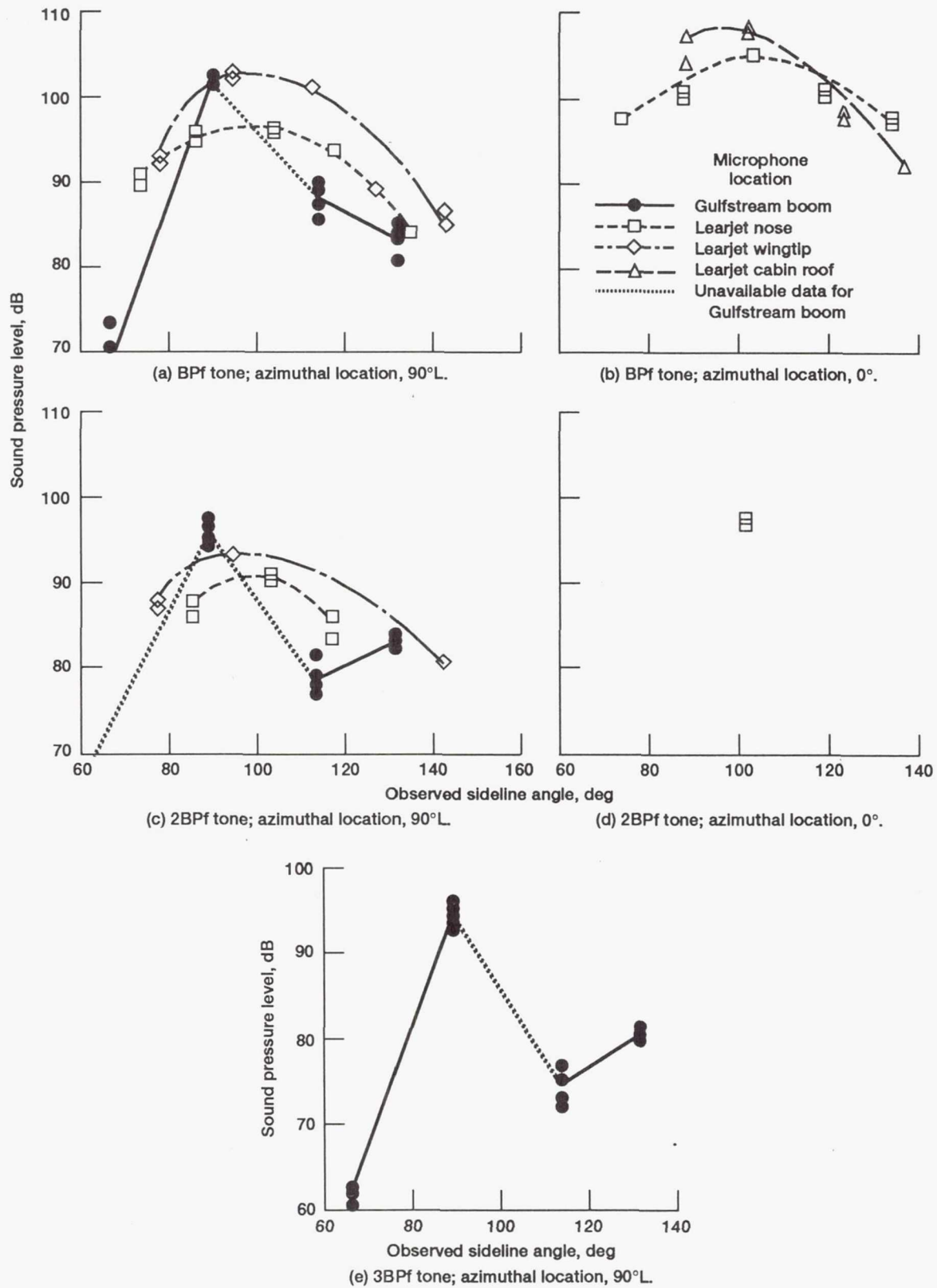

Figure 27.—PTA aircraft sideline directivity for case 8 conditions. Mach 0.70; altitude, 10 668 m (35 000 ft); data adjusted to 152-m (550-ft) free field conditions.

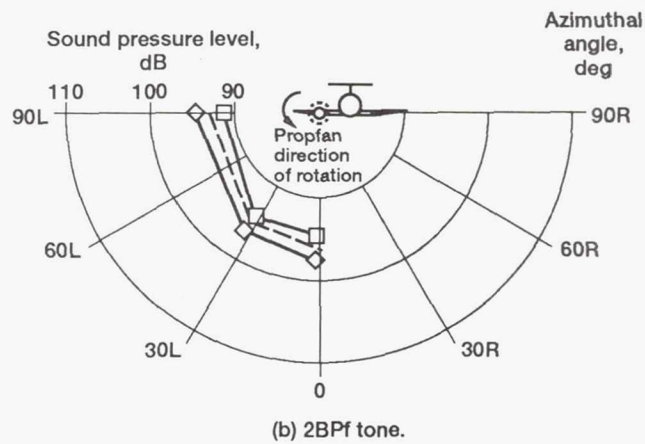
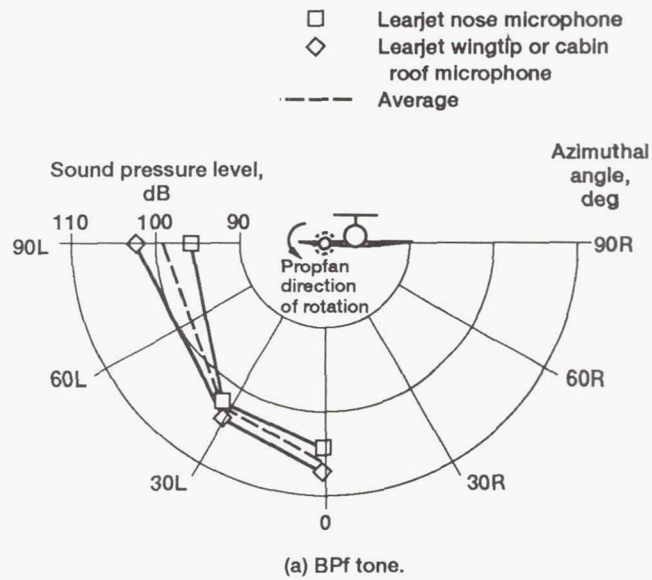

Figure 28.—PTA aircraft azimuthal directivity viewing upstream for case 8 conditions. Mach 0.70; altitude, 10 668 m (35 000 ft); data adjusted to 152-m (500-ft) free field conditions.

REPORT DOCUMENTATION PAGEForm Approved
OMB No. 0704-0188

Public reporting burden for this collection of information is estimated to average 1 hour per response, including the time for reviewing instructions, searching existing data sources, gathering and maintaining the data needed, and completing and reviewing the collection of information. Send comments regarding this burden estimate or any other aspect of this collection of information, including suggestions for reducing this burden, to Washington Headquarters Services, Directorate for Information Operations and Reports, 1215 Jefferson Davis Highway, Suite 1204, Arlington, VA 22202-4302, and to the Office of Management and Budget, Paperwork Reduction Project (0704-0188), Washington, DC 20503.

1. AGENCY USE ONLY (Leave blank)		2. REPORT DATE April 1993	3. REPORT TYPE AND DATES COVERED Technical Memorandum	
4. TITLE AND SUBTITLE In-Flight Near- and Far-Field Acoustic Data Measured on the Propfan Test Assessment (PTA) Testbed and With an Adjacent Aircraft			5. FUNDING NUMBERS WU-535-03-10	
6. AUTHOR(S) Richard P. Woodward and Irvin J. Loeffler				
7. PERFORMING ORGANIZATION NAME(S) AND ADDRESS(ES) National Aeronautics and Space Administration Lewis Research Center Cleveland, Ohio 44135-3191			8. PERFORMING ORGANIZATION REPORT NUMBER E-6402	
9. SPONSORING/MONITORING AGENCY NAME(S) AND ADDRESS(ES) National Aeronautics and Space Administration Washington, D.C. 20546-0001			10. SPONSORING/MONITORING AGENCY REPORT NUMBER NASA TM-103719	
11. SUPPLEMENTARY NOTES Responsible person, Richard P. Woodward, (216) 433-3923.				
12a. DISTRIBUTION/AVAILABILITY STATEMENT Unclassified - Unlimited Subject Category 71			12b. DISTRIBUTION CODE	
13. ABSTRACT (Maximum 200 words) Flight tests to define the far-field tone source at cruise conditions have been completed on the full-scale SR-7L advanced turboprop that was installed on the left wing of a Gulfstream II aircraft. This program, designated Propfan Test Assessment (PTA), involved aeroacoustic testing of the propeller over a range of test conditions. These measurements defined source levels for input into long-distance propagation models to predict en route noise. In-flight data were taken for seven test cases. Near-field acoustic data were taken on the Gulfstream fuselage and on a microphone boom that was mounted on the Gulfstream wing outboard of the propeller. Far-field acoustic data were taken by an acoustically instrumented Learjet that flew in formation with the Gulfstream. These flight tests were flown from El Paso, Texas, and from the NASA Lewis Research Center. This report presents a comprehensive listing of the aeroacoustic results from these flight tests which may be used for future analysis.				
14. SUBJECT TERMS Turboprop aircraft; Aircraft noise; PTA; Flight test			15. NUMBER OF PAGES 161	
			16. PRICE CODE A08	
17. SECURITY CLASSIFICATION OF REPORT Unclassified	18. SECURITY CLASSIFICATION OF THIS PAGE Unclassified	19. SECURITY CLASSIFICATION OF ABSTRACT Unclassified	20. LIMITATION OF ABSTRACT	