



11-11-91
1677-8

P-112

1991 LIFE SUPPORT SYSTEMS ANALYSIS WORKSHOP

Milwaukee, Wisconsin
June 24-27, 1991

WORKSHOP REPORT

March 1, 1992

Peggy L. Evanich
Thomas M. Crabb
Charles F. Gartrell

Office of Aeronautics and Space Technology
National Aeronautics and Space Administration
Washington, D.C. 20546

(NASA-CR-4466) 1991 NASA LIFE
SUPPORT SYSTEMS ANALYSIS WORKSHOP
Final Report, 1991 (Orbital
Technologies Corp.) 112 p

N93-27100

Unclas

H1/54 0162968

This document is the product of support from many organizations and individuals. The Orbital Technologies Corporation, under contract to General Research Corporation, conducted the workshop, developed the proceedings, and prepared the final report.

Sponsored by: National Aeronautics and Space Administration
NASA Headquarters
Code R
Washington, DC 20546

COTR: Gregory M. Reck

Task Monitor: Peggy L. Evanich

Contract Number and Title: NASW-4470
Space Technology Studies and Support

Contractor: General Research Corporation
Aerospace Systems Group
1900 Gallows Road
Vienna, VA 22182

Subcontractor: Orbital Technologies Corporation
402 Gammon Place, Suite 10
Madison, WI 53719

Program Manager: Charles Gartrell

Task Leader: Thomas M. Crabb

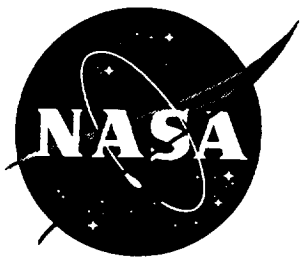

**1991
LIFE SUPPORT SYSTEMS ANALYSIS
WORKSHOP**

Milwaukee, Wisconsin
June 24-27, 1991

WORKSHOP REPORT

March 1, 1992

Peggy L. Evanich
Thomas M. Crabb
Charles F. Gartrell

Office of Aeronautics and Space Technology
National Aeronautics and Space Administration
Washington, D.C. 20546

All references to commercial products are comments expressed by the workshop participants and do not represent a position taken by the U.S. Government.



DISTRIBUTION

Allen S. Bacskay
Code ED62, Bldg T285
NASA Marshall Space Flight Center
MSFC, AL 35812
(205) 544-0993

Mark G. Ballin
Code SAS, M/S 239-8
NASA Ames Research Center
Moffett Field, CA 94035
(415) 604-5771

Mr. Michael Barrera
Aspen Technology, Inc.
251 Vassar Street
Cambridge, MA 02139
(617) 497-9010

Dr. W.B. Bedwell
Allied Signal
50 E. Algonquin Rd
Des Plaines, IL 60017-5016
(708) 391-3500

Albert F. Behrend, Jr.
NASA Johnson Space Center
2101 NASA Road 1, CODE EC3
Houston, TX 77058
(713) 483-9241

Dr. Lawrence Beigler
MCS Division
Argon, IL 40439

Mr. Vincent Bilardo
Code SAS, M/S 239-8
NASA Ames Research Center
Moffett Field, CA 94035
(415) 604-5752

Dr. Attilio Bisio
ATRO Associates
Box 1367
Mountainside, NJ 07092
(908) 233-1524

Dr. Ray Bula
University of Wisconsin
1357 University Avenue
Madison, WI 53715
(608) 262-5526

Mr. Mel Cobb
Lockheed Missiles & Space Company
P.O. Box 3504, ORG 6N-12/B580
Sunnyvale, CA 94088-3504
(408) 756-6832

Ms. Carolyn Cooley
Martin Marietta Civil & Space Comm
P.O. Box 179, M/S DC8001
Denver, CO 80201
(303) 971-9375

Mr. Robert DaLee
McDonnell Douglas Space Systems Co
689 Discovery Drive, Mail Code 12C3
Huntsville, AL 35806
(205) 922-7320

Ms. Susan Doll
Boeing Aerospace Company
P.O. Box 240002, M/S JX-23
Huntsville, AL 35824-6402
(205) 461-3731

Dr. Alan Drysdale
McDonnell Douglas Space Systems
P.O. Box 21233
Kennedy Space Center, FL 32815
(407) 383-3819

Peggy L. Evanich
OAST, Code R
NASA Headquarters
Washington, DC 20546
(202) 453-2843

Martha Evert
Lockheed/ESC
2400 NASA Rd 1, MC-C44
Houston, TX 77058
(713) 244-5111

Dr. Michael Fehling
Terman Engineering Center
Stanford University
Stanford, CA 94305-4025
(415) 723-0344

Mr. Joseph Ferrall
Jet Propulsion Laboratory
4800 Oak Grove Drive, M/C 125-224
Pasadena, CA 91109
(818) 354-3159

Mr. John Fisher
Code SAR, M/S 239-11
NASA Ames Research Center
Moffett Field, CA 94035
(415) 604-4400

Ms. Susan Fuhs
AIRResearch
P.O. Box 2960, M/S T-41
Torrance, CA 90509-2960
(213) 512-4600

Dr. Gani B. Ganipathi
Jet Propulsion Laboratory
4800 Oak Grove Dr, M/S 125-224
Pasadena, CA 91109
(818) 354-7449

Scott Gilley
Sverdrup Technology, NASA LeRC
21000 Brookpark Road, M/S 309-1
Cleveland, OH 44135
(216) 433-6137

Mr. Ian Gosling
Aspen Technology, Inc.
251 Vassar Street
Cambridge, MA 02139
(617) 497-9010

Mr. Stephen Gustavino
McDonnell Douglas Space Systems Co
5301 Bolsa Avenue, Mail Code 17-B
Huntington Beach, CA 92647
(714)896-3311

Mr. Joseph Homa
Hamilton Standard
One Hamilton Road, M/S 1A-2-W66
Windsor Locks, CT 06096
(203) 654-2495

Vibhor Jain
Bionetics Corporation
NASA Ames Research Center, MS 239-8
Moffett Field, CA 94035
(415) 604-1335

Darrell Jan
Jet Propulsion Laboratory
4800 Oak Grove Drive, M/C 125-224
Pasadena, CA 91109

Mr. Matthew Kolodney
Lockheed Engineering & Science Co
2400 NASA Road 1, M/C C70
Houston, TX 77058
(713) 333-7224

Mr. Richard Lamparter
NASA Ames Research Center
Mail Stop 239-11
Moffett Field, CA 94035
(415) 604-1159

Mr. William Likens
Code SAS, M/S 242-4
NASA Ames Research Center
Moffett Field, CA 94035
(415) 604-3210

Cheng-Hsiung Lin
Purdue University
Lorre/Potter Center, Rm 220
West Lafayette, IN 47907
(317) 494-7027

Dr. Chin Lin
NASA Johnson Space Center
2101 NASA Road 1
Houston, TX 77058
(713) 483-9126

Thomas M. Maloney
Sverdrup Technology, NASA LeRC
21000 Brookpark Road, M/S 309-1
Cleveland, OH 44135
(216) 433-6137

Dr. David Ollis
Chemical Engineering Department
North Carolina State University
Raleigh, NC 27695
(919) 737-2329

Dr. Firooz Rasouli
7449 N. Natchez Avenue
Niles, IL 60648-3892
(312) 647-9000

Mr. Barney Roberts
NASA Johnson Space Center
2101 NASA Road 1, Code IE2
Houston, TX 77058
(713) 283-5460

Dr. Naresh Rohatgi
NASA Jet Propulsion Laboratory
4800 Oak Grove Drive, M/S 125-224
Pasadena, CA 91109
(818) 354-3073

Dr. Willy Sadeh
Department of Civil Engineering
Colorado State University
Fort Collins, CO 80523
(303) 491-2001

Nelson Schlater
Bionetics Corporation
NASA Ames Research Center, MS 239-8
Moffett Field, CA 94035
(415) 604-1335

Dr. Richard Seagrave
Iowa State University
Sweeney Hall, Room 238
Ames, IA 50011
(515) 294-0518

Dr. P.K. Seshan
NASA Jet Propulsion Laboratory
4800 Oak Grove Drive, M/S 125-224
Pasadena, CA 91109
(818)354-7215

Dr. Charles Simonds
Lockheed Missiles and Space
1150 Gemini Ave, M/C A23
Houston, TX 77058
(713) 282-6203

Dr. Kamallesh K. Sirkar
Stevens Institute of Technology
Castle Point
Hoboken, NJ 07030
(201) 420-5432

Dr. Robert Sirko
McDonnell Douglas Space Systems Co
5301 Bolsa Avenue, Mail Code 13-2
Huntington Beach, CA 92647
(714) 896-3817

Mr. Thomas Slavin
Boeing Aerospace & Electronics Division
P.O. Box 3999, M/S 84-15
Seattle, WA 98124
(206) 773-1471

Mr. Paul Spurlock
S&A Automated Systems, Inc.
123 NW 13th Street, 13th Floor, Ste 222
Boca Raton, FL 33432
(407) 750-8786

Dr. Ted Tibbitts
University of Wisconsin
Room 327, Horticulture
Madison, WI 53706
(608) 262-1816

Mr. William Trail
Aspen Technology, Inc.
251 Vassar Street
Cambridge, MA 02139
(617) 497-9010

Raymond B. Trusch
Hamilton Standard
One Hamilton Road
Windsor Locks, CT 06096
(203) 654-2495

Dr. George Tsao
Purdue University
Potter Building-1295
West Lafayette, IN 47907
(317) 494-7022

Dr. Tyler Volk
New York University
26 Stuyvesant Street
New York, NY 10003
(212) 998-8995

Raymond M. Wheeler
NASA Kennedy Space Center
Code MD-RES
Kennedy Space Center, FL 32899
(407) 853-5142

Dr. Lionel R. Whitmer
Boeing Missiles and Space Division
P.O. Box 240002, M/S JR-34
Huntsville, AL 35824-6402
(205) 461-5854

Mr. Versie L. Wilson
Boeing Missiles and Space Division
P.O. Box 240002, M/S JR-34
Huntsville, AL 35824-6402
(205) 461-5822

Dr. Bruce Wright
Boeing Missiles and Space Division
499 Boeing Blvd, M/S JR-34
P.O. Box 240002
Huntsville, AL 35824-6402
(205) 461-5822

THIS PAGE INTENTIONALLY LEFT BLANK

TABLE OF CONTENTS

	<u>Page</u>
1.0 WORKSHOP OBJECTIVES AND SUMMARY	1 - 1
2.0 SUMMARY OF CONCLUSIONS AND RECOMMENDATIONS	5 - 2
3.0 STEADY STATE AND DYNAMICS SYSTEMS ANALYSIS WORKING GROUP RESULTS	9 - 3
4.0 MODEL VALIDATION AND SCALE-UP ASSESSMENT WORKING GROUP RESULTS	15 - 4
5.0 EVALUATION CRITERIA WORKING GROUP RESULTS	23 - 5
6.0 BIOLOGICAL SYSTEMS ANALYSIS WORKING GROUP RESULTS .	27 - 6
7.0 SYSTEMS INTEGRATION WORKING GROUP RESULTS	33 - 7
APPENDICES	41
A. DETAILED AGENDA	43
B. LIST OF WORKSHOP PARTICIPANTS	51
C. WORKING GROUP PRESENTATIONS	57

LIST OF FIGURES

1. NASA Life Support Technology Programs Use of Systems Analysis	2
2. Life Support Systems Analysis Workshop Time Line	2
3. System Dependency Matrix	34
4. Propulsion Interfaces With Power and Life Support	35
5. Power Interfaces with Life Support and Propulsion	35

THIS PAGE INTENTIONALLY LEFT BLANK

1.0 WORKSHOP OBJECTIVES AND SUMMARY

1.1 Workshop Overview

The NASA Life Support Systems Analysis Workshop was sponsored by NASA Headquarters' Office of Aeronautics and Space Technology (OAST) to foster communication among NASA, industrial, and academic specialists, and to integrate their inputs and disseminate information to them. Life support technologies will require a broad base of systems modeling experience. Adequate validation of models and appropriate capability to scale-up prototype processes will be necessary to model and develop longer-duration life support systems that may ultimately be self-sufficient. The specific goals of this workshop were to report on the status of systems analysis capabilities, to integrate the chemical processing industry technologies, and to integrate recommendations for future technology developments related to systems analysis for life support systems.

NASA is coordinating the life support systems analysis development through several technology programs, shown in Figure 1. These efforts support the development of input data, modeling algorithms, and validation of key life support technologies that will be integrated into an operational system. The overall objective of systems analysis within the Life Support Technology Program of OAST is to identify, guide the development of, and verify designs which will increase the performance of the life support systems on component, subsystem, and system levels for future missions beyond the currently planned Space Station.

The Workshop, held over three days (25-27 June 1991) in Milwaukee, Wisconsin, included technical presentations, discussions, and interactive planning, with time allocated for discussion of both technology status and time-phased technology development recommendations. Key personnel from NASA, industry, and academia, currently involved with life support technology developments, delivered inputs and presentations on the status and priorities of current and future technologies. Figure 2 provides an overview of the workshop organization, while Appendix A contains the detailed agenda.

1.2 Workshop Sessions and Presentations

The workshop contained six technical sessions, four working group sessions, two real-time software demonstration sessions, and a luncheon keynote address. Comments from an initially planned NASA review panel, for reasons of time conservation, were integrated into the working group presentations and into the last technical presentation session.

PRECEDING PAGE BLANK NOT FILMED

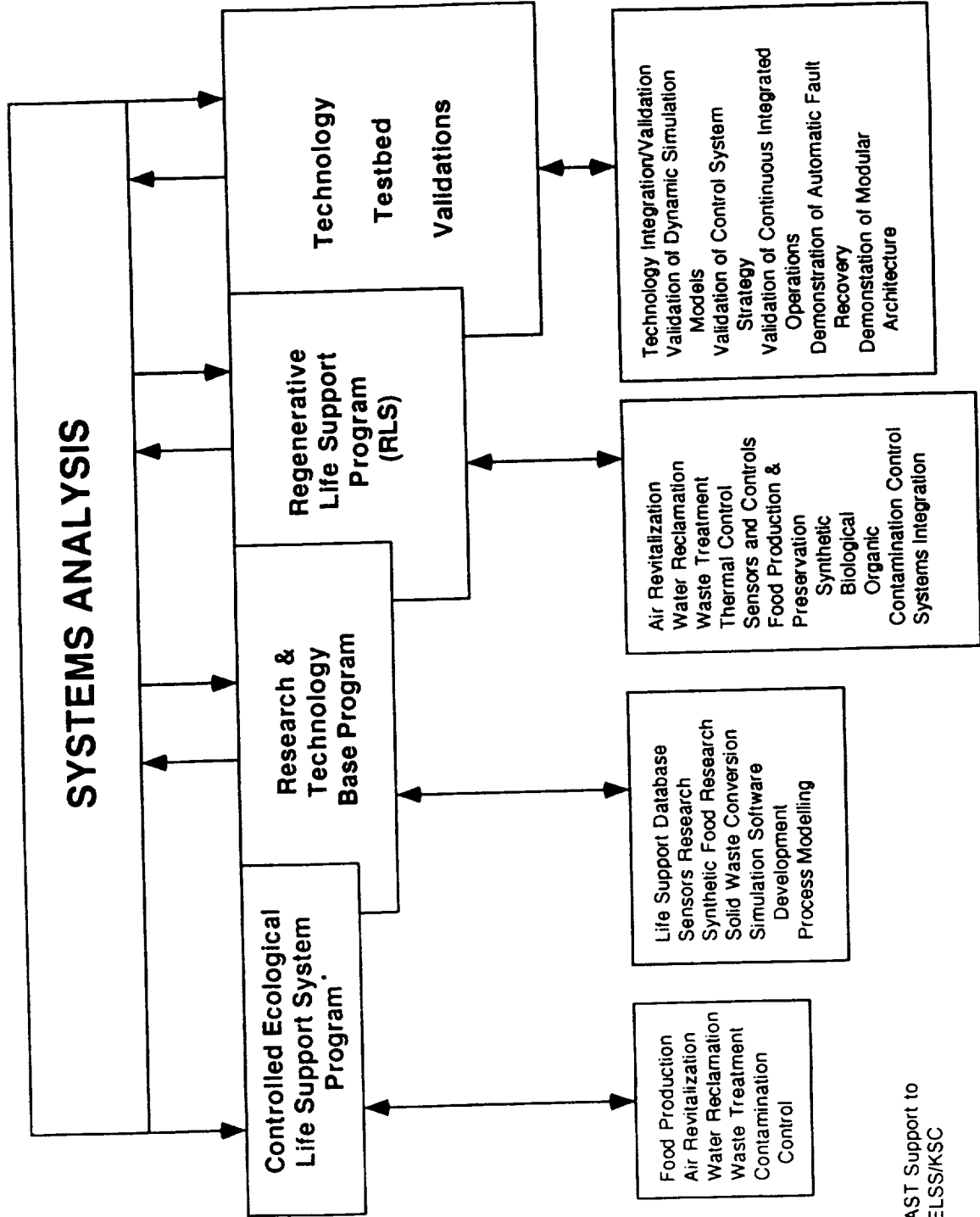

• OAST Support to CELSS/KSC

FIGURE 1. NASA Life Support Technology Programs Use of Support Systems Analysis

	8:00 am	9:00 am	10:00 am	11:00 am	12:00 noon	1:00 pm	2:00 pm	3:00 pm	4:00 pm	5:00 pm	6:00 pm
TUESDAY	Intro	NASA Life Support Systems Analysis Capabilities/Tools		WorkGp Kick Off	Lunch Presentation: LSS Strategies	Analogous Systems Analysis Approaches/Tools		Break	Working Group Meeting #1		Reception
WEDNESDAY	Software Demonstration Presentations		Life Support Applications of Systems Analysis		Lunch (on your own)	Evaluation Criteria and Future Analysis		Working Group Meeting #2			
			Software Demonstration (One-on-One Discussions)								
THURSDAY	Working Group Presentations		LSS Project Sum								

FIGURE 2. Life Support Systems Analysis Workshop Time-Line

Presentations within the six technical sessions highlighted NASA goals for systems analysis for life support, status of current NASA model developments, insight into systems analysis from the chemical processing industry, applications and examples of the NASA systems analysis modeling, future analysis approaches and evaluation mechanisms, and an overview of the NASA life support technology program. Specific sessions included:

- *Introduction and Overview.* A welcome and an overview, by Peggy Evanich, of the NASA life support technology program goals and their relationship to the systems analysis and the goals of the workshop. Future requirements for life support technologies and applications induce the need for additional development and analysis relating to figures of design and operational merit.
- *Overview of NASA Life Support Systems Analysis Capabilities/Tools.* Five presentations highlighting the NASA model developments using ASPEN PLUS, CASE/A, G189A, and spreadsheet tools. Modeling levels ranged from process simulation to the integration of component and subsystems performance models into a total system.
- *Analogous Systems Analysis Approaches/Tools.* Insights from three chemical industry systems-analysis experts into concerns of scale-up, validation of actual systems implementation vs. expected or planned performance, and optimization techniques to minimize iteration requirements.
- *Life Support Application of Systems Analysis.* Four presentations of systems analysis applications relating to Space Station Freedom, Extra-Vehicular Activity (EVA) suit subsystems, Lunar Outpost, and Mars Exploration.
- *Future Analysis Approaches and Evaluation Criteria.* Six presentations addressing detailed systems integration analysis, the role of Artificial Intelligence (AI) in future systems analysis, integration of biological systems analysis, decision analysis techniques, and evaluation mechanisms/tools.

NASA Life Support Systems Analysis Workshop

- **Overview of NASA's Life Support Technology Program.** A NASA/ARC review of the Physical-Chemical Regenerative Life Support Project, including management structure, approach to developments, and near-term planned activities. NASA/JSC provided an overview of the Lunar Base Life Support Testbed activity.

Appendix A lists full presentation titles and their respective presenters. Copies of presentations were compiled in a workbook and distributed to participants at the workshop.

Barney Roberts, Manager of the Planet Surface System Office at NASA/JSC, presented an overview of the Lunar and Mars mission scenarios, including insights into the role of life support systems within planetary surface bases.

1.3 Working Groups

Five working groups were formed to apply the specialized talents and experiences of workshop attendees to discussions of these specific systems analysis development areas:

<u>Working Group</u>	<u>Working Group Chairman</u>
Steady State and Dynamics Systems Analysis	Dr. P.K. Seshan, JPL
Modeling Validation and Scale-up	Dr. Chin Lin, NASA/JSC
Evaluation Criteria	Mr. Allen Bacskay, NASA/MSFC
Biological Systems Analysis	Dr. Raymond Wheeler, NASA/KSC
Systems Integration	Dr. Naresh Rohatgi, JPL Mr. William Likens, NASA/ARC

Each working group articulated key development issues relating to systems analysis, an assessment of the current state-of-the-art, and potential recommendations for pursuit of those issues. Working group efforts and milestones were divided across the workshop's three days. The first day was devoted to defining the key issues and characterizing the state-of-the-art or the status of current developments. The second day continued with development of recommendations for each of the key issues identified. Working group leaders presented reports on the third day. These reports appear in Appendix C, and are summarized in Sections 3 through 7.

2.0 SUMMARY OF WORKSHOP RESULTS AND RECOMMENDATIONS

The NASA Life Support Systems Analysis Workshop provided an excellent opportunity for NASA, industry (aerospace and chemical processing), and universities to collaborate on modeling and analysis techniques and tools for advanced life support. The contributions of key personnel in many disciplines yielded valuable results, which are summarized in this section. Common needs identified throughout the working groups included:

- Investigation of the effects of micro/partial gravity affects to life support process and system simulation and analysis.
- NASA guidance in development of standards for developing simulation modules, prototype and testbed testing procedures, and data collection and communication.
- Additional workshops and/or agency-wide advisory groups to support a united technology analysis and development program for life support.
- Integration of the physical-chemical and biological systems.
- Significant technology development and basic research in waste treatment and resource recovery.
- Additional analysis of system controls and other operational factors in early design phases.

2.1 Steady State and Dynamics Systems Analysis Working Group Summary

The Steady State and Dynamics Systems Analysis Working Group addressed current and future needs for systems analysis approaches, tools, and techniques. Key issues identified and recommended as priorities for future activities included:

- Develop additional generic-component simulation modules and guidelines that induce a commonality among any life support component model for use with many systems analysis tools.
- Determine systems parameters that are needed for rigorous dynamics simulation, and generate rigorous dynamics simulation, especially in the design and analysis of control systems.

- Obtain experimental and design data from technology developers, and implement requirements in future design, development, and fabrication procurement to supply data appropriate to systems analyses.
- Identify and document the design parameters, modeling algorithms and driving mechanisms (physical, chemical, transport and thermodynamic) of life support systems and technologies affected by micro/partial gravity. A workshop on this subject would reveal significant effects from existing modeling and experimental data, and identify new experiments where necessary.
- Develop property data for trace contaminant control modeling.

2.2 Model Validation and Scale-up Assessment Working Group Summary

The Model Validation and Scale-up Assessment Working Group addressed: 1) the effects and relationships of systems analysis with testbed prototypes of various levels, and 2) integrated systems analysis data and results to projected real-life systems applications. Key issues/recommendations included:

- Develop guidelines for prototype and testbed design, to account for appropriate sizing based on the relative size of the life support system application, and to include testing and data collection that directly relates to validation and scale-up within systems analysis models.
- Develop data collection capabilities to enhance interfaces between the systems analysis modelers and the testbed developers and evaluators, such that iterations and free transfers of data are possible and appropriate between modeling results and hardware testing results.
- Conduct more prototype/testbed activities to verify scale-up correlations both on a component level and on a systems level, to identify economies of scale that may not always be obvious or may not always be accurate.
- Investigate the effects of micro/partial gravity in the governing equations of process simulations, perform thorough study of gravity-sensitive processes, and conduct tests to characterize those sensitivities.
- Develop a standardized validation test series guideline through establishment of rigorous experiment design techniques and an advisory panel to include NASA, industry and academic members.

2.3 Evaluation Criteria Working Group Summary

The Evaluation Criteria Working Group addressed the parameters, methods, and tools used to evaluate the life support system technologies and designs, from component-level hardware through system level designs, as well as from the conceptual design phase through flight operations phases. Key issues/recommendations addressed by the working group included:

- Develop consistent evaluation criteria that depend on the phase of the development cycle and the level of component/systems analysis, and methods to combine appropriate evaluation criteria into a single measure of performance.
- Investigate strategies and techniques for identifying and implementing life support system evaluations, including various systems analysis, decision analysis, life cycle cost, and/or dimensional analysis techniques.
- Expand the evaluation factors and modeling parameters of life support systems and components to include operational and other reliability/maintainability factors, even in early phases of development and analysis.

2.4 Biological Systems Analysis Working Group Summary

The Biological Systems Analysis Working Group addressed basic issues of data requirements, tools, and techniques required for systems analysis of life support technologies that integrate biological component(s). Key biological systems analysis issues/recommendations developed by the working group included:

- Develop consistent approaches for biological life support systems testing through experimental set-up guidelines, data reporting guidelines, and a central focus for biological systems data.
- Begin augmenting the currently available data on primary production and waste treatment through additional controlled testing of specific biological components and systems.
- Augment long-term and large-scale biological systems testing through many time constants of the biological system.
- Develop data on human behavioral effects relating to the presence or absence of biological systems, through literature searches and human behavioral evaluation related to isolated environments.

- Initiate detailed testing and analysis to determine the driving factors in various biological systems (e.g., primary production, waste treatment) affected by micro/partial gravity.

2.5 Systems Integration Working Group Summary

The Systems Integration and Analysis Working Group addressed the future potential and related requirements for analyzing and assessing the potential of integrating the life support systems with other systems in future mission architectures such as the Initial Lunar Outpost, an evolved lunar base, a Mars base operation, and manned transit vehicles.

Two levels of integration exist. A top-level systems integration analysis can utilize estimated mass and resource interfaces among the life support system and other systems (power, thermal, propulsion, etc.) to predict the level of synergism among integrated systems. A second level of integration, much more detailed, could then be conducted on systems that have potential for performance pay-offs because of synergistic integration, involving detailed simulation and systems modeling of each system/component and the interfaces with other systems/components.

Overall recommendations by the working group included:

- Sponsor a meeting of key technical staff involved in life support, power, propulsion, thermal and other systems that may potentially be integrated with the life support system.
- Analyze possible high pay-off system interactions involving the life support system, including effects of integration on risk, maintainability, and reliability. Although integrated systems may initially demonstrate beneficial relationships that reduce resupply through synergistic uses of common resources, they may be less beneficial operationally, when reliability and maintainability of additional and integrated systems are considered.
- Investigate potential use of common materials and components from other systems and potential application of life support materials and components to other systems, including standard interfaces and connectors.
- Assess effects of systems integration to the evolution and growth of the life support system.

3.0 STEADY STATE AND DYNAMICS SYSTEMS ANALYSIS WORKING GROUP

The Steady State and Dynamics Systems Analysis Working Group addressed current and future needs of systems analysis approaches, tools, and techniques. The working group was chaired by Dr. P. K. Seshan of the Jet Propulsion Laboratory; participants are listed at the end of this section.

Key issues included:

- Additional generic component simulation modules are needed.
- Rigorous dynamic simulation should be pursued and evolved with systems and technology developments to mainly support control system development.
- Experimental and design data from technology developers would significantly improve modeling accuracy.
- Development of a property data for trace contaminant control modeling is required.
- Effects of micro/partial gravity on modeling must yet be integrated to current models.

Other issues discussed but not fully developed by the working group included:

- Dynamic simulation modeling can form a basis for the operational control system development.
- Various levels of modeling, from process simulation to subsystem/system level modeling, are required to accurately estimate performance.

3.1 Generic Component Simulation Modules

ASPEN Plus and CASE/A have many modules, but are not always generic and usable by various software tools. However, some modules needed for life support systems analysis are not built-in or readily available. Many of the life support process units and unit operations are not generic but could be expressed in terms of one or more built-in generic modules of software packages. ASPEN Plus provides for custom building of new modules. Thus, ASPEN is one tool that could be used to generate additional generic modules.

RECOMMENDATIONS - Generic Component Simulation Modules:

- Additional generic modules are needed, including:

Electrochemical reactor	
Ion exchange	Clothes washer
Membrane Separator	Clothes drier
Plant	Toilet
Metabolic humans	Shower
Kitchen	Metabolic animal
Dishwasher	Bioreactors (various kinds)

- A more rigorous Vapor Compression Distillation (VCD) module is needed for CASE/A.
- Module development by users should follow specific format and assumption guidelines such that they may be interfaced across several systems analysis tools. The module developers should therefore agree on module structure/interface. Standardization of generic modules would allow sharing of modules, and would minimize duplication of effort among many systems analysis tools.

3.2 Rigorous Dynamic Simulation in Life Support Systems Analysis

CASE/A, G189A, SPEEDUP and SIMTOOL have various aspects of steady state and dynamic simulation capabilities. ASPEN Plus can simulate transient performance of individual blocks by using RBATCH and custom code modules capable of executing sophisticated integration algorithms.

CASE/A and G189A do not contain the standard tools for control system analysis (i.e., analysis of performance dynamics). MATRIX, System Build, and MATLAB are control system design/analysis software packages; however, they are not chemical process simulation packages. Only one commercial chemical process simulator, SPEEDUP by Prosys Technology, can simulate dynamics within a block and across an entire flow sheet using sophisticated integration methods. However, SPEEDUP is not very user-friendly.

Rigorous dynamic simulations are needed for system response and controllability studies, for control system design and testing, but not for systems analysis. Rigorous dynamic simulations are not needed during conceptual system studies and technology development. They have little relevance to system parameters such as weight, volume, power demand, etc.

RECOMMENDATIONS - Rigorous Dynamic Simulation in Life Support Systems Analysis:

- Quasi-steady state simulation capability in ASPEN Plus should be developed to monitor changes in storage tanks.
- Rigorous dynamic simulations must be part of the design review process, especially for transient thermal response of process equipment including highly exo/endermic chemical reactors.
- Dynamic simulations should be used at the conceptual stage for early concept definition of control strategies.
- Standard guidelines should be developed to identify the level of dynamics simulation detail required for modeling of components systems of various natural response frequencies.

3.3 Experimental Data from Technology Developers to Support Systems Analysis

Component and subsystem packaging may have an important effect on the ability to scale up weight and volume. Data pertaining to the optimal performance of a component alone will not be adequate, since system-wide optimum performance may necessitate suboptimal component performance.

RECOMMENDATIONS - Experimental Data from Technology Developers to Support Systems Analysis:

- Gather the following data for different sizes of process equipment, and throughout (and slightly beyond) the nominal operating envelopes:
 - Performance data on failure modes, including failure of a redundant component.
 - Weight, volume, and other applicable data of individual process units, instruments, wiring, plumbing, fittings, support structures, insulation/lagging and any other packaging materials/structures.
 - Basic chemical reaction data such as kinetic rate constants and equilibrium constants for reactions, as well as hardware dependent data such as flow rates, power demand, etc.
 - Operating conditions such as temperature, pressure, feed concentrations, etc., as well as performance parameters such as percent conversion/separation.

- All technology development proposals must contain a section on scale-up, detailing approaches and deliverables to enable scale-up correlations to be developed. All technology development proposals must be reviewed by system analysis personnel with experience in process simulation and equipment scale-up. Their recommendations and data as described above should be made part of the contract deliverables.

3.4 Micro/Partial Gravity Effects on Thermodynamic, Transport and Kinetic Properties

Several contractor and NASA reports are available on the subject of microgravity effects on components and subsystems. A 1990 Lockheed Engineering and Science Company report includes many of the governing equations. Gravity affects transport processes; thermodynamic properties are not expected or known to be affected by the magnitude of gravity. Equilibrium properties of finely divided particles, bubbles and droplets, however, could exhibit gravity dependence. Typical Earth-gravity phenomena are often overcome in microgravity environments due to homogenous mixings of multiple phases and surface energy effects.

RECOMMENDATIONS - Micro/Partial Gravity Effects:

- Generate a micro/partial gravity effects database relative to life support systems.
- Sponsor a NASA workshop of experts in properties measurements to identify currently available information on gravity effects on life support systems related processes, and define potential experiments to be conducted in micro/partial gravity environments to generate missing data for the above database.
- Use aircraft micro/partial gravity flights to simulate the various gravitational environments in which life support systems must operate. Development of an automated flight profile controller would help to optimize the desired gravity environment, maximize duration in low gravity simulations, and increase reproducibility of acceleration profile. Current designs are available for such an aircraft instrumentation system.
- Plan, establish, and fund a program of chemical and physical properties measurements on Space Station Freedom.

3.5 Property Data for Trace Contaminant Control Modeling

ASPEN Plus contains a large database, can calculate properties based on molecular structure, and can track trace chemicals in the model by setting extremely tight tolerances on convergence. These trace contaminants may greatly affect the performance of life

support components. For example, trace contaminants such as methane and carbon monoxide may also affect the life cycle and size of the Bosch unit, and must be accurately accommodated.

Some trace contaminants may not be known until prototyping and testing. In these cases, additional modeling must be pursued to determine the source of the contamination, any problems which may affect performance, and solutions to alleviate the contamination.

RECOMMENDATIONS - Trace Contaminant Property Data:

- Obtain kinetic data for trace contaminants not found in the ASPEN Plus database, through literature search or experiments. Since possible contaminants are too numerous to model and track in any single simulation, the preferred modeling approach would organize the known contaminants into ten or fewer classes and select a representative compound for each class for modeling trace contaminant processes in life support systems.
- Iterate trace contamination modeling with component and system prototype testing to analyze and verify unexpected contamination problems.

3.6 CONTRIBUTORS

P.K. Seshan (Chair)
Michael Barrera
Scott Gilley
Mark Ballin

Tom Crabb
John Fisher
Matt Kolodney

Joe Ferrall
V. L. Wilson
R.C. DaLee

THIS PAGE INTENTIONALLY LEFT BLANK

4.0 MODEL VALIDATION AND SCALE-UP ASSESSMENT WORKING GROUP

The Model Validation and Scale-up Assessment Working Group addressed the effects and relationships of systems analysis with testbed prototypes of various levels, and integration of those data to projected real-life systems applications. The working group defined validation as "a mechanism to integrate real data produced from hardware experiments into the modeling analysis to improve user confidence in the results of the models." Dr. Chin Lin of NASA JSC chaired the working group. The participants are listed at the end of this section.

Key issues highlighted by the working group report include:

- Prototype and testbed requirements are needed to standardize and maintain good results for use in systems analysis.
- Data collection requirements could be standardized and made available to enhance integration of data in modeling and scale-up assessment.
- Scale-up data is required from prototype/testbed for use in model validations and scale-up estimation.
- Effects of micro/partial gravity need to be addressed to identify driving mechanisms which will affect modeling, analysis, and scale-up assessment.
- Validation test series must be a continuous process from benchtop tests through flight operations.

4.1 Prototype and Testbed Requirements

To date, existing life support technologies have been prototyped and developed only for modeling and analysis validation on a component or subsystem level. In addition, most hardware data now available for advanced life support technologies are at bench-top or pre-prototype levels. Development of standard requirements or guidelines for prototyping and testbed development would more consistently generate useful and valid data to compare and validate with systems analysis models. Such guidelines should include proper prototyping and testing design and operation so that the accumulated data supports development of accurate scale-up correlations (see Section 4.3).

Two major supporting issues were identified. The first supporting issue was the ability to determine whether test data were developed with prototype/testbed sizes within a justifiable

range of the modeling application(s). By experience, researchers have found that the valid range of test data extrapolation is very small, centering around the size of the prototype. Scale-up from these limited data is often insufficient and inaccurate because of unknown influences which create different correlations for systems at different size levels.

The second supporting issue concerned the need for validation and scale-up to be considered at both component and integrated system levels, each of these representing very different approaches. The validation and scale-up of components depends largely on the parameters and assumptions directly related to the process simulation. However, integrated systems validation and scale-up are more commonly affected by the interactions of several components/subsystems rather than by a domination of a single process.

Another current problem with existing data used in validation and scale-up is that the data available for various components of a life support system come from prototypes of a wide range of sizes. Also, inadequate parameter sensing and data collection within the prototype or testbed hardware can leave many holes within the database.

At this time, math/computer models are not used regularly to support scale-up of life support systems. This type of analysis and mathematical representation of scale-up has only recently been implemented. When using such models, only scale-up correlations validated through appropriately sized prototypes and testbeds should be used to determine economies of scale, and to define parameters whose correlations are significantly affected by changes in scale.

This represents, at a basic level, a protocol of modeling and testing that requires iteration of modeling/analysis and experimental prototypes/testbed developments. The data collected during prototype/testbed evaluations and the data used and derived through modeling must be similar if not identical. Also, the assumptions and operational environment of the analyses and testing must be similar for comparison.

RECOMMENDATIONS - Prototype and Testbed Requirements:

The working group recommended the pursuit of two modes of validation and scale-up prototyping and testbed activities. The first recommendation is to build and test prototypes at incremental levels up to at least one-fourth of the flight hardware capacity. Thus, different missions and different life support systems may require different levels of prototyping and different stages within the prototype series to develop proper validation and proper scale-up correlations. These levels of prototyping at the systems level will impact the component-level prototype sizing and testing.

Secondly, the working group recommended prototyping and testing a series of testbeds at both the component level and the integrated systems level. Component-level prototype testing and characterization, if conducted with procedures and in sizes relevant to the ultimate integrated system, can lead to integration of the component-level prototypes into

an integrated system testbed to determine the inter-component relationships and related scale-up correlations. This is already being planned at the JSC, and the working group recommended following up this activity with a very coordinated series of prototypes and testbeds across the entire life support system within this testbed activity.

4.2. Data Collection Requirements

Hardware and test data must be efficiently collected, reported and organized to support proper use within the modeling and analysis, and to enhance proper comparisons among prototypes and testbeds at differing technologies and sizes.

A specialized life support systems technology database has been started at the ARC; however, it is unclear whether a single, centralized database could ever be totally complete and include all necessary information for modeling all of the processes, components, subsystems, and integrated systems. A preferred approach would be a centralized pointer system, which merely directs inquiries to the correct source of valid data. For this option, the data would be maintained throughout the nation (and the world) at the originating locations, where updates may be recorded in a more timely fashion. Also, substantially more data may become available from additional sources of information (for example, data collected by Boeing and Lockheed). One problem cited is the reluctance of many organizations, private or public, to permit access to such data for competitive or proprietary reasons. A necessity of either approach is a protocol of data which includes output results, assumptions used, and specific configuration information of the process or hardware.

System-level test data, and some component-level test data, are rather limited in range and number of parameters tested. Basic understanding and determination of fundamental driving mechanisms within processes to support validation of systems performance modeling are, in many cases, incomplete. Such incompleteness leads to a lack of parameter detail to track and provide, as a data set, information that can be used in validation and scale-up efforts. Also, the lack of knowledge of fundamental driving mechanisms affects the validity and accuracy of scale-up correlations developed from such data.

Chemical industries do not invest any funds into a production process without knowing these driving mechanisms, without knowing what is key to the scale-up correlations, and without knowing what is key to the overall component subsystem and system performance. Developing tests and prototypes to isolate individual parameters is required to identify some of these driving mechanisms. Modeling and analysis can help identify these driving mechanisms, but they must then be proven and validated in a testbed situation.

RECOMMENDATIONS - Data Collection Requirements:

- **Continue expansion and enhancement of a centralized database or database network. Incorporate or at least identify the source of relevant test data on various life support hardware.**
- **Open better channels of information exchange between the private sector and NASA so that existing test data on currently used hardware can be made more consistently available.**
- **Make a commitment to acquire necessary data from model validation and development of scale-up correlations. This includes establishing a generalized protocol for defining the test assumptions and set-up requirements such that the test data is compatible with the systems being modeled. Thus the modeling and analysis must provide input into test requirements. This input could be a list of data and parameters to track, identification of potential key driving mechanisms to watch for, pre-test predictions of output data from the test model, and other environmental/operational requirements under which the testbed would operate. In addition, there must be sufficient resources in the hardware testing program for sensor placement, monitoring, and storing of in-depth measurements of specific parameters that are isolated from other variables, and to conduct many of these experiments and tests over wide ranges of operation. Specific protocols exist in which to support experimentation development to minimize the number of experiments based on the number of dependent and independent variables that need to be tracked.**

4.3. Scale-up of Prototypes/Testbeds

Developing scale-up correlations from prototypes and testbeds raises questions of which analysis techniques should be used, whether the data used and available is adequate for the scale-up correlations, and which mechanisms should be used to coordinate the modeling analysis with the hardware scale-up correlations. To date, test data are not usually collected during the prototype or testbed to support various scale-up assessments. Data is lacking to accurately verify the parameters represented in the data sets of a specific process subsystems and to adequately predict performance of large crew life support systems. For example, most currently available test data exists only for crew sizes smaller than four. This is considered extremely inadequate to accurately scale-up a component or a subsystem to capacities larger than 16-person crews.

To the present, scale-up correlations have been typically developed in parallel with other modeling and analysis features, but not as an integral part of the modeling and analysis. The working group recommended procedures to integrate the scale-up correlations directly into the modeling and analysis, initial development, and later verification.

Dimension and similitude analysis techniques need to be used across the board and in a more standardized fashion with respect to both component- and system-level scale-up procedures. Scale-up correlations may be quite different for components and integrated systems. Compiling the scale-up correlations of many integrated components may not adequately reveal the scale-up correlations that will be found in the integrated system. Validation of scale-up correlations of the system-level hardware is also definitely required.

RECOMMENDATIONS - Scale-up of Prototypes/Testbeds:

- Develop and verify through testing scale-up correlations along two major influences of performance estimation: level of integration and overall size magnitude. Scale-up correlation development and verification may begin at the process or component level, but must also be developed for integrated subsystems and systems. Because scale-up correlations are rarely linear and influencing mechanisms change as the size of the component/system increases, this scale-up correlation must be developed and verified for various sizes appropriate to the ultimate application.
- The scale-up correlation must take advantage of systems analysis, process modeling, and prototype testing to support more accurate development of scale-up correlations. Broader use and iterative integration of hardware scale-up correlations into the modeling and analysis should be pursued.
- Dimension analysis and similitude analysis must be pursued on a more common and across-the-board basis at both the component and systems levels.

4.4. Effects of Micro/Partial Gravity

In developing model and systems analyses, using data from component- and subsystems-level tests in a 1-g environment may not, and probably will not, assure accurate performance estimation in a micro/partial gravity environment. Key driving mechanisms must be explored within the process simulation and in the component interactions at the systems level to assure that the validation of 1-g testbeds is accurate for micro/partial gravity applications.

Gravity is not an explicit parameter in most life support systems modeling analyses; however, it may play a crucial role in some of the microprocesses that occur within the life support systems. Independent studies have identified certain processes such as gas/liquid interfaces in life support systems that are very sensitive to levels of gravity. Other processes within life support systems that have been shown to be affected include buoyancy, electrolytic double generation, steam condensation and certain biological plant growth effects.

To date, some components and sub-systems have been tested in different orientations on Earth to drive out what may be some of the effects on component or system performance

from various gravity environments. Other tests and flight experiments conducted on aircraft and the Space Shuttle, as well as tests currently planned for Space Station Freedom are ascertaining gravity effects in life support component performance. However, to date, no rigorous comparative testing of sister component prototypes has been made from Earth-based to micro-g-based to lunar-based to Mars-based gravity levels.

RECOMMENDATIONS - Micro/Partial Gravity Effects:

- Re-examine the governing equations used in current systems analyses, process simulations and other models to verify that the gravity effects within the assumptions are justifiably negligible or adequately applied.
- Perform a thorough study to identify g-sensitive processes and develop test requirements for new and emerging life support technologies so that gravity effects can be appropriately estimated and validated.
- For g-sensitive processes, conduct ground tests and parallel or sister flight experiments to measure directly the effects of gravity. These may be conducted on aircraft simulations, and potentially on Space Station Freedom should a centrifuge be developed to provide partial gravity. They may also be tested on aircraft flight experiments, the Space Shuttle, and station racks for micro-g effects.
- Study current life support systems in the shuttle and planned life support systems in Space Station Freedom to determine the gravity effects on already-developed hardware.

4.5. Validation Test Series

Validation is a living process, starting from the benchtop test to the full flight test; it is not a single-event determination. Typical timeframes for development of life support systems are on the order of a decade or more. Typical cycles in the chemical industry are on the order of a year. Thus, many more tests and validation activities could occur to assure adequate performance of the life support systems throughout the development cycle. The build-up of test data will be vital to the determination of systems performance through systems analysis modeling. No well-defined test strategy exists to accumulate relevant data in adequate quantity or quality to support validation of current systems modeling and analysis.

RECOMMENDATIONS - Validation:

- Use rigorous experiment design techniques to maximize return of necessary testing. This includes the Design of Experiments (DOE) technique to minimize the number of experiment runs to isolate a certain number of variables and parameters.

- Form an agency-wide advisory group including representatives of industry and academia to formulate a consistent and comprehensive testing strategy. The testing strategy must stress consistency within the operational procedures, parameters monitored and measured, and reporting and storage of data. The initial set-up and operating environment, inputs to the test, and any other assumptions must be maintained with the output data.
- Maintain iterative coordination between the modeling and systems analysis such that the results of modeling can feed into testbeds and the data coming out of testbeds can improve the accuracy of systems analysis models.

4.8 CONTRIBUTORS

Chin Lin (Chair)
Vibhor Jain
Chin Lin
Kamalash Sirkar

W.B. Bedwell
Darin Kohles
David Ollis

Mel Cobb
Bill Likens
Firooz Rasouli

THIS PAGE INTENTIONALLY LEFT BLANK

5.0 EVALUATION CRITERIA WORKING GROUP

The Evaluation Criteria Working Group addressed the parameters, methods, and tools used to evaluate the life support system technologies and designs from component-level hardware through mission architecture designs, as well as from the conceptual design phase through flight operations phases. The working group was chaired by Allen Bacskay of NASA/MSFC. Participants are listed at the end of this section.

Key issues addressed by the working group included:

- Consistency of evaluation criteria is required to enable synergy around NASA developments and missions.
- Approaches exist to develop and implement viable ECLSS evaluations.
- Elaboration of ECLSS drivers.

5.1 Consistency of Evaluation Criteria

Systems evaluation criteria are constantly driven by the diversity of design and development goals within NASA component research initiatives (e.g., bioregenerative emphasis of OSSA vs. physical-chemical emphasis of OAST) and the disparity in scale of projected mission requirements (e.g., achieving low earth orbit vs. habitating the moon vs. exploring Mars). However, with the recent need for synergistic cooperation, overall evaluation criteria should be consistent with a few high-priority goals common throughout NASA and among all missions. From these high-level criteria, supporting evaluation criteria may be developed.

RECOMMENDATIONS - Evaluation Criteria Consistency:

- Develop a set of criteria that is mutually acceptable to all groups involved and readily applicable to their needs. This may reduce subjectivity of decision-making in mixed research programs through consistent and logical evaluations. This includes evaluation criteria that is technically based as well as criteria imposed from the political structure. Honesty in development of the evaluation criteria will enhance the probability that the end-item development will meet original expectations.
- Sponsor a working group or workshop with representatives from all ECLSS constituent disciplines to provide a balanced and coherent view of significant issues. Distribute background information and currently used evaluation criteria (as a conceptual springboard) to attendees, with the expectation of generating productive discussions and producing a mutually acceptable evaluation method that is independent of mission type and duration.

- Establish varying levels of evaluation criteria based on the phase of the program (conceptual design vs. flight prototypes) and level of analysis (component level vs. systems level). In each of the varied levels, flow-down of design requirements and associated evaluation criteria must occur downward (i.e., from the more advanced development stage to the less advanced development stage, and from the system level to the component level).

5.2 Candidate Strategies for ECLSS Evaluations

The working group discussed three existing approaches that involve development and use of systems evaluation criteria. Study of the following approaches may provide useful insights to life support systems analyses:

- The approach demonstrated by a Lockheed systems analysis manual, which begins with a clearly identified objective. (Reference: Holtzman, Samuel, 1988, Intelligent Decision Systems, Addison-Wesley, Reading, MA, 288 pp.)
- Decision analysis that does not require a perfectly articulated objective as a starting point, and that can accommodate changing emphases over time. (Reference: Space Systems Division Systems Engineering Manual, Code 66, June 1985, Lockheed Missile and Space Co., a unit of Lockheed Corp., Sunnyvale, CA, 301 pp.)
- Life cycle cost, which can be used to evaluate any objective requirement or resource, offers a common unit of comparison, and purportedly increases in accuracy as the project advances.

RECOMMENDATIONS - Evaluation Strategies:

- Develop single, most important criterion at each of various levels of hardware (component through system) and at each of various phases of development (concept through operations).
- Use standardized analysis approach (decision analysis, life cycle cost analysis, etc.) to establish the evaluation criteria to represent the ultimate goals of life support systems developments.

5.3 Elaboration of ECLSS Design Drivers

Mass, volume, and power are generally acknowledged to be the most critical engineering factors in designing extraterrestrial missions. But, as the scope and duration of projected missions increases, other factors become more important and may overwhelm the effects of mass, volume and power. For example, a design may save 50 pounds of mass, but decreases

reliability such that the total mass requirement over the lifetime of the life support system exceeds the initial savings several times over.

RECOMMENDATION - ECLSS Drivers:

Assess the impact of operational and reliability/maintainability factors. Examples of such factors include: crew preference, resupply needs, functionality, recoverability, maturity, and safety margins, as well as reliability, EVA time, IVA time, readiness, verifiability, palletizability, heat flux, residence time, acidity, total organic carbon, toxicity, organolepticity, gravity field sensitivity, absorptivity, corrosion rate, and resistance to corrosion.

5.4 Other Issues Raised But Not Specifically Discussed

Several issues, raised but not analyzed in depth, should be reopened at the next workshop. These include:

- Determine an accurate costing of research and development, and operations that include typically hidden government infrastructure costs.
- Definitions of "system," "subsystem," "component," and "process" should be clarified and standardized (and sub- and super-systems).
- Relationship between the functionality and cost of the life support systems should be defined as a function of closure.
- Procedures for applying weighting factors in life support system criteria are critical to overall systems evaluation and sensitivity/trade-off assessment.
- The effects of "requirement creep" during the development phase can drastically affect the evaluation criteria and determination of an optimal approach.
- Iterative modeling studies and testbed assessments should be based on a consistent set of criteria.
- Regeneration vs. resupply benefits must be assessed based on evaluation criteria.
- Evaluation criteria must account for the availability of in-situ resources.
- Applications of deterministic vs. probabilistic assessments should be determined and recommended as guidelines.

NASA Life Support Systems Analysis Workshop

- Commonalities among bioregenerative and physical-chemical approaches may provide a good evolutionary growth and should be identified.
- Breakpoints and large paybacks in technology development need additional assessment and identification.
- "Palatability" criteria such as astronaut's dietary preference needs to be integrated into other design and performance criteria.
- Innovative life support system evaluation criteria should be investigated.
- Flow-downs of requirements and configurations changes to the evaluation criteria are of major importance to designers and scientists during development.
- Judgments based on non-technical or non-economical basis should be avoided or at least documented in the evaluation criteria.

5.8 CONTRIBUTORS

Allen Bacskey (Chair)
Martha Evert
Nelson Schlater
Lionel Whitmer

Susan Doll
Joe Homa
Chuck Simonds
Tom Woodzick

Alan Drysdale
Willy Sadeh
Paul Spurlock

6.0 BIOLOGICAL SYSTEMS ANALYSIS

The Biological Systems Analysis Working Group addressed basic issues of data requirements, tools, and techniques required for systems analysis of life support systems containing biological subsystems/component(s). Dr. Ray Wheeler from NASA Kennedy Space Center chaired the working group; participants are listed at the end of Section 6.0.

Key biological systems analysis issues developed by the working group included:

- Consistent approaches are needed for biological life support systems testing.
- Additional data is required on primary production and waste treatment.
- Long-term data on biological system operation will improve systems analysis results.
- Data on human behavior relating to biological systems will increase the overall performance of the crew and should be reflected in relevant evaluation criteria.
- Effects of micro/partial gravity on biological systems are important factors for process assessment and analysis.

Data requirements for food processing and development of a data repository for biological system characteristics were identified but not discussed in detail.

6.1 Consistent Approaches for Biological Life Support Systems Testing

A consistent or standardized approach for biological life support system testing does not currently exist. Several experimental procedures are being followed with varying operational conditions. Many test data sets are incomplete, and others do not identify the operational setups and conditions under which the tests were conducted.

RECOMMENDATIONS - Biological Testing Approaches:

- Define the critical inputs and outputs and controlling factors.
- Consider the multi-variable response surface approaches rather than merely defining optimum levels based on two variables.
- Employ statistical tools to handle the variability.
- Develop a generic repository for biological systems data for use in a standard modeling approach.

6.2 Availability of Data for Primary Production and Waste Treatment

Data on biological systems are often scarce or nonexistent. Much of the existing data is available only from small laboratory scale bench-top prototypes. The available information to predict the performance and characteristics of an entire life support system using a biological processing component may not be appropriate or accurate for primary production and waste treatment. A categorized status of data for various biological systems follows.

● PRIMARY PRODUCTION

- | | |
|--------------------------------------|--|
| - Food / Biomass Production | Good, extensive data |
| - Water Transpired (Distilled) | Extensive data |
| - Carbon Dioxide Removed | Some direct measurements
(e.g., KSC Biomass Production Chamber)
Extensive data from biomass calculations |
| - Oxygen | Produced few direct measurements (e.g., KSC BPC)
Can be estimated from biomass production data |
| - Contaminants (trace) | Very little data |
| - Environmental response/performance | Extensive data
Not all conducive to multi-variable response surface analysis |

● WASTE TREATMENT AND RESOURCE RECOVERY SYSTEMS

- | | |
|--|---|
| - Cellulose Conversion | Limited data, bench-top level |
| - Aerobic Treatment Systems | Little data
Commercial technology data available e.g., sewage treatment |
| - Anaerobic Treatment Systems | Less data than aerobic treatment systems
Commercial technology data available e.g., sewage treatment |
| - Biomass Leaching to Recover Minerals | Limited data |

- Aquaculture/Animal Systems for Conversion of Inedible Biomass Limited data

- **MASS REQUIREMENTS ESTIMATES**
 - Productivity of crops Limited integrated system data. Area needs, lamp/ballast needs, water requirements, and waste treatment systems will dictate the mass requirements.

 - Plant Culture System Little data reported, but should be obtainable
 Good data available on area/volume requirements
 Crop performance allows estimation of mass requirements

 - Biological Waste Treatment/Resource Recovery Little data available
 Some data on water volume/mass of aquaculture systems

- **ENERGY REQUIREMENTS ESTIMATES**
 - Plant Lighting Good data on irradiance levels
 Power requirements may be calculated

 - Heating, Ventilation, and Air Conditioning (HVAC) Little data from direct measurements
 Good estimates should be obtainable

 - Water Pumping Few direct measurements
 Estimates easily obtainable

 - Waste Treatment Systems Little data

RECOMMENDATIONS - Primary Production and Waste Treatment Data:

- Establish the mass, power, and volume requirements for operating biological primary production and waste treatment systems.

- Initiate testing of various biological waste treatment and resource recovery systems to generate data useful in modeling system operation.
- Address the lack of data on animal systems for use in waste management, and initiate survey of possible animal (e.g., other than microbiological) options for waste conversion. Possible candidates include fish, poultry, and insects to convert inedible plant biomass and provide a protein supplement for humans. Assess the advantages and disadvantages to each.
- Identify power, mass and volume requirements for plant cultural activities, harvesting, and food processing.

6.3 Long-Term Data on Biological Systems Operations

The data and experience of biological systems is largely based on short duration, single generation tests. Also, the testing environment is rarely closed to itself and does not represent a biological life support system/component that will rely on less than 100% effective performance of resource recovery. Thus, long-term and large-scale effects over many biological time constants are rarely input into the systems analysis model. Because of this, an integrated biological life support system cannot currently be modeled accurately.

RECOMMENDATIONS - Long-Term Operations Data:

- Initiate/continue large-scale studies to assess scale-up problems for biological systems.
- Initiate long-term studies to assess performance of biological systems over several biological time constants.
- Initiate tests of biological systems that are not open-looped but require resource recovery without "fresh," unperturbed resource inputs.

6.4 Human Behavior Data

A lack of research has left insufficient data relating to human behavior and the presence or absence of plants. No research studies could be referenced to help determine a positive or negative effect of plant life to human behavior and any related improvement of human performance.

RECOMMENDATIONS - Human Behavior Data:

- Conduct extensive literature search for human response/behavior studies assessing the benefit (or problems) of having plants nearby and/or benefits from engaging in horticultural activities in an isolated environment.
- Initiate studies of human response and behavior in isolated living/working areas with and without plants (e.g., psychological benefits studies).
- Factor results from literature and/or surveys into modeling approaches assessing the advantages of different life support systems.

6.5 Micro/Partial Gravity Effects on Biological Systems

Very little data is available on partial gravity effects on primary production of biological systems, and no such data is available for biological waste treatment systems. Correlations of systems performance in micro/partial gravity environments cannot be predicted without some valid data points. The basic driving mechanisms must be determined at the various gravity levels to support adequate analyses and modeling.

RECOMMENDATIONS - Micro/Partial Gravity Effects:

- Initiate a testing program to characterize the operation and productivity of biological systems (especially plant production and waste treatment systems) under micro/partial gravity through aircraft, suborbital, Space Shuttle, and future Space Station Freedom flight experiments.
- Support basic research to estimate the effects of micro/partial gravity on biological systems, from the understanding of the basic driving mechanisms and physics/chemistry.

6.6 Other Biological Systems Analysis Conclusions/Recommendations

Expensive biological systems software exists, but very little information exists to be entered into it. Workshop participants agreed that consistency in the approaches for testing and data gathering was critical. Additionally, there should be a "fine tuning" of experimentation to obtain data about the optimum primary production/processing performance, and decrease the data and assumption variability. The compilation of a "Journal of Life Support" was also suggested.

6.7 CONTRIBUTORS

**Ray Wheeler (Chair)
Alan Drysdale
Stephen Gustavino
Dick Seagrave
George T. Tsao**

**Ray Bula
Gani Ganipathi
Janis Moths
Robert Sirko
Tyler Volk**

**Carolyn Cooley
Ian Gosling
Nelson Schlater
Ted Tibbitts
Bruce Wright**

7.0 SYSTEMS INTEGRATION WORKING GROUP

The Systems Integration and Analysis Working Group addressed the future potential and related requirements for analyzing and assessing the possibility of integrating the life support systems with other systems in future mission architectures such as the Initial Lunar Outpost, an evolved lunar base, and a Mars base operation, as well as in the transit vehicles involved in those mission architectures. The working group was co-chaired by Dr. Naresh Rohatgi of the Jet Propulsion Laboratory and William Likens of NASA Ames Research Center. Participants are listed at the end of this section.

Integration exists at two levels. A simplified systems integration analysis can take advantage of estimated mass and resource transfers among the life support system and other systems such as power, thermal, propulsion, etc., to predict the level of synergism among integrated systems. A more-detailed level of integration analysis could then be conducted on specific large pay-off integrations through detailed simulation and systems modeling of each system and its interfaces.

This working group addressed the more-detailed analysis approach and concentrated on identifying the physical interfaces between the life support system and other technologies and systems. Other considerations that should be included in systems integration analysis but were not addressed in detail within this working group because of time limitations include: standards, materials, connectors and interfaces, component and design commonalities, reliability, and risk dependencies. A first-cut dependency identified by the working group (shown in Figure 3) involved interaction of the life support system with the power system, thermal system, in-situ resource systems, propulsion systems, and laboratory systems. These dependencies apply not only to surface-based architectures, but also to surface vehicles and EVA systems where life support systems exist. Each of these system integrations will be discussed independently in the subsections below.

The integration of in-situ resources would decrease the necessary resupply for a less-than-closed life support system. In addition, common storage vessels and facilities and common ground handling technologies may be very advantageous. Some of the in-situ resource developments may also be successfully integrated with power and propulsion in thermal systems.

Provides Support \ Receives Support	Power	Thermal	EVA	In-situ Resources	Propulsion	Laboratory	Construction & Manufacture	ECLSS
Power	-	⊗		⊗		⊗	⊗	⊗
Thermal	⊗	-		⊗		⊗	⊗	⊗
EVA			-	⊗				
In-situ Resources				-	⊗			⊗
Propulsion			⊗		-			?
Laboratory						-		
Construction & Manufacture							-	
ECLSS	?	?	⊗		?			-

⊗ LSS Related Dependency

⊗ Possible Further Dependency

? Other non - LSS Dependencies

FIGURE 3. System Dependency Matrix

7.1 Integration with the Power System

Key interactions of life support systems with power systems could include uses of common fluids and exchanges of fluids between the power system and life support system. Common storage and common resource utilization are possible, whether those resources are supplied in-situ or delivered from a remote logistical node. An example of such interface may be the regenerated fuel cell, in which water, oxygen and hydrogen are exchanged between the two systems. Other power technologies that may interface with the life support system include the solid-oxide fuel cell, nuclear power system, and photovoltaic systems. Some of these interfaces are shown in Figures 4 and 5.

The physical interfaces between the two systems are key to accurate performance modeling. For example, simulation of a regenerative fuel cell integration with the life support system provides for individual simulations of the oxygen, hydrogen, and water resources within each system, and simulates the interaction of water and hydrogen/oxygen flows between the systems.

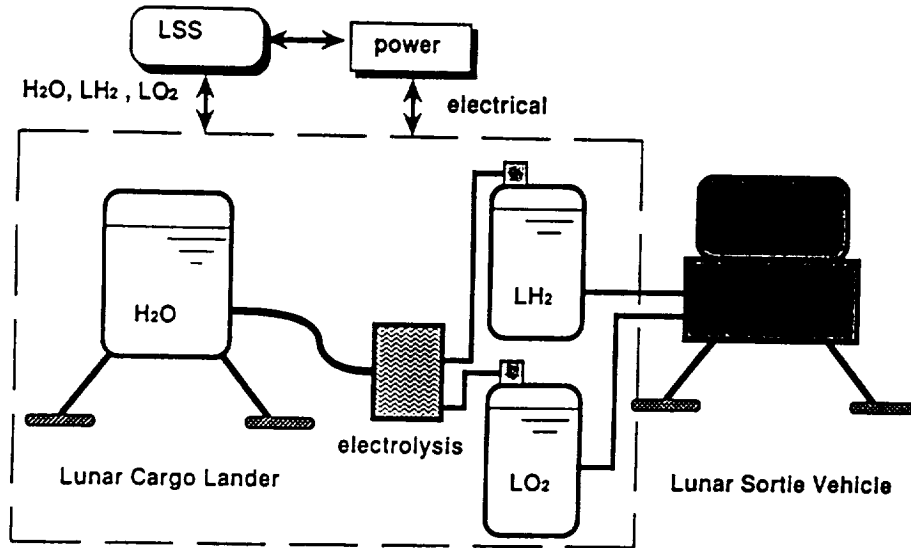

FIGURE 4. Propulsion Interfaces With Power and Life Support

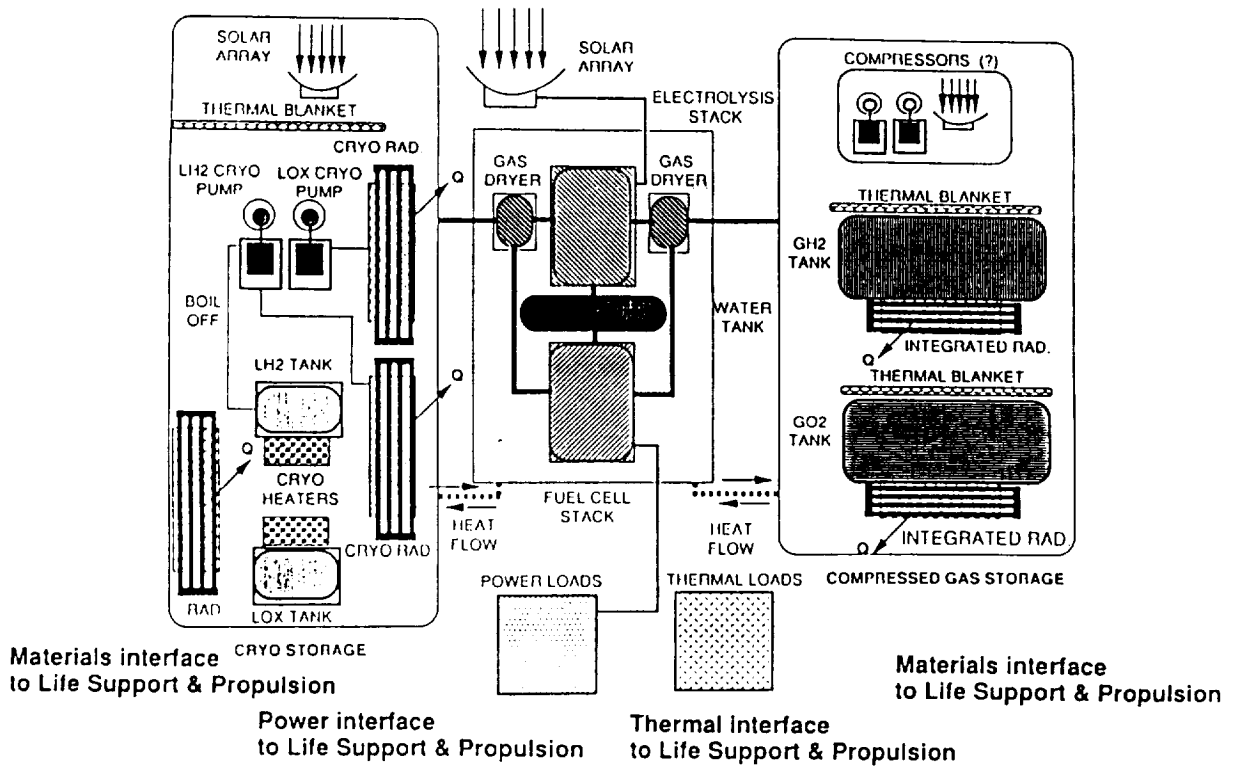

FIGURE 5. Power Interfaces with Life Support and Propulsion

7.2 Integration with Thermal System

Common interfaces between the thermal system and life support system may include sharing of water and storage systems for either water or air. The life support system could interact with the thermal system to eliminate and add heat depending on the changing impacts of equipment heat dissipation and external thermal considerations.

Modeling of the physical resource interfaces between the two systems is key to the prediction of overall benefits of the integration synergism. Performance modeling of the integrated system and the life support system must accommodate the transfer parameters of a common fluid. Also, heat-balancing synergism may occur from various subsystems within the life support systems and from subsystems external to the life support system.

7.3 Integration with Propulsion Systems

The integration of the propulsion system(s) with both the power system and the life support system looks very promising, but depends on the specific propulsion systems being integrated. Some of these interactions were shown in Figures 4 and 5.

Hydrogen/oxygen propulsion systems have a good potential for resource sharing in common storage fluids such as water, hydrogen, and oxygen. This may also integrate well with a regenerative fuel-cell power system.

Hydrazine propulsion also exhibits some potential integration with the life support system, since hydrazine will decompose into nitrogen and hydrogen. The nitrogen can be used as make-up gas in a life support system, and the hydrogen can be used as a fuel source within the life support system, particularly in carbon dioxide reduction technologies.

Electric propulsion could share some of the same fluids used by the life support system, such as hydrogen, methane and nitrogen. Such electric propulsion systems include nuclear-thermal propulsion ion thrusters, arcjets, the magnetodynamic ion thrusters. Other, more advanced propulsion systems, such as fusion rockets, may be able to use common fluids such as hydrogen.

Other considerations of integration with the propulsion systems must consider the availability and use of in-situ resources.

7.4. Integration With In-situ Resources Utilization (ISRU)

Several commonalities among the In-Situ Resource utilization (ISRU) developments at different nodes within the lunar and Mars infrastructure can be combined and integrated with the life support system to enhance its performance. The infrastructure required to process local resources is, in most cases, not trivial and is typically more massive and power

consumptive than simply resupplying the materials/resources. The operational costs of the ISRU; however, can induce a cost payback after only a few years of operation. The payback is enhanced if synergistic use of the locally produced resources is shared among several systems such as the life support system.

Oxygen, hydrogen, nitrogen, and several other volatile elements are available from lunar regolith processing. Carbon dioxide may be retrieved from the Mars atmosphere for use in plant growth chambers, or for direct conversion to oxygen for the life support system, and/or to produce methane (when combined with hydrogen) for power production or propulsion. On Mars, ice/water may be retrieved from the planetary surface, below the planetary surface or from the nearby Mars moons.

Other elements, such as aluminum or magnesium from lunar regolith or Mars soils, may be used with oxygen from the lunar regolith as fuels for a waste-processing system/subsystem within the life support system.

Lunar regolith or Mars soil may be configured in either a solid or granular bed formation for filtration or absorption.

7.5. Integration With Laboratory Systems

The capability of the life support system to handle human by-product and food by-product wastes is extremely important. This capability could be integrated with laboratory systems such that waste from the laboratory could also be handled in a single waste-handling unit subsystem. Although these waste streams may be segregated from the life support system itself, waste-handling technologies and development costs may be shared among certain components.

7.6. Integration With Construction and Manufacturing

The basic integration of the life support system with associated construction and manufacturing activities is characterized by the reuse of life support system wastes. For example, ash from a supercritical water oxidation facility might be used in a shielding for a lunar base or other vehicle.

Waste plastics from food or other packaging may be remanufactured into new packaging or decomposed into carbon and hydrogen for use elsewhere in the life support system, and/or could be used as radiation shielding. Other waste materials may be remanufactured into foils, structures, or other packaging material.

Spent tanks and other resupply units may be used in the life support system for storage of resupply resources, or to increase buffers of storage. Excess water from the life support system may also be used as radiation shielding, but may also be used with power systems. Any waste streams from the life support system may be collected and simply composted with lunar regolith to eventually, over a period of years, build up a soil matrix that could be used and integrated into a later biological plant growth cycle.

7.7. Integration With EVA Systems

The Extra-Vehicular Activity (EVA) system is a potential source of possible contamination to the life support system, including dust collected from surface activity, or hydrazine spill vaporized on orbit and collected on the spacesuit. However, the life support requirements for EVA suits and transfer vehicles require similar recharging and refurbishment, which utilizes resources that are common to the typical life support system. For example, water, oxygen and nitrogen will be key to the resupply and recharge of EVA systems. This recharge may be most economically done through a slight augmentation of the life support system on the larger based vehicle or planetary base.

7.8. Existing Software for Modeling Integrated Systems

Three large model developments were acknowledged in the working group for performing integrated systems analysis:

- Integrated Systems Performance Model (ISPM) represents a true dynamic model of Space Station Freedom's integrated systems, which include electrical power generation and distribution, thermal control system, guidance and attitude control system, life support and environmental control, and solar/thermal external environment. The structure is in MATRIX 1 System Build from Integrated Systems, Inc., in Santa Clara, CA. It has been applied successfully to the Space Station Freedom integrated systems preliminary design review and restructuring design efforts. The contact person is John Tandler of Grumman in Reston, VA.
- Integrated Systems Analysis Tool for Space Exploration Initiative integrates several subsystems and other related disciplines such as cost modeling, mission design, and trajectory analysis. It has been developed by Rockwell International using IR&D funds. The contact person is Henry W. Woo or David Haines of Rockwell, Downey.
- The Systems Design Trade-off Model integrates systems analysis tool models from all of the systems on Space Station Freedom. This modeling includes cross-coupling effects between systems, and incorporates cost modeling capability. The model was

originally developed by JPL for the Space Station Freedom Program Office in Reston, VA. The contact at JPL is Jeff Smith.

Several other systems models exist to link resource-dependent integration aspects of systems and subsystems. A few of these other models include the large-scale programs institute model developed with JSC in Lotus 1-2-3, and the Functional Analysis and Sensitivity Trade-off Evaluation Model (FASTEM) in Pascal, to integrate technologies in various mission systems as well as integrating total infrastructure requirements at various nodes. Each aerospace contractor has mechanisms to consider the systems integration issues; some of them are computer models, others are not. Several other models have been developed to perform systems integration and systems-integration modeling with respect to the SDI program. However, no common mechanism exists within NASA to do or assemble systems integration modeling and analysis tools.

7.9 Integration With Base Vehicles

Base vehicles such as orbital transfer vehicles and rovers could be recharged and renovated through the augmentation of the larger nodal life support system much like the interface of EVA systems to the larger life support system. This recharge could involve resupply of breathing gases, water, food, etc., as well as the collection and processing of wastes from the vehicles. Also, the vehicle's power system could be recharged through resupply of basic fuels such as hydrogen, oxygen and methane. These base vehicles could also operate as alternative safe havens and backup systems for the primary life support system. Integrating the base vehicle life support system with the larger nodal life support system could be very advantageous, not only to reduce base life support system logistics through minimizing resupply, but also to take advantage of the infrastructure of the vehicles as redundant safe havens. One caution is to avoid any potential for cross-contamination from one life support system to another.

7.10 Overall Recommendations

The recommendations of the Systems Integration and Analysis Working Group are as follows:

- NASA should sponsor a meeting of key technical capabilities involved in power, propulsion, life support, thermal and other systems having integration potential to life support system, and should arrange overview briefings in the following areas:
 - Overall understanding of each system
 - Typical resource requirements, and flows in and out of each system
 - Applications of systems in various mission architectures
 - Potential integration of technology developments and testing
 - Potential pay-offs and benefits of integration

NASA Life Support Systems Analysis Workshop

- Screen the list of possible interactions and integrations among other systems and the life support system, using analysis of risk and reliability dependencies and other system engineering techniques.
- Investigate possibilities for common materials and components from among systems including standard interfaces and connectors.
- Assess the reliability and maintainability of integrated systems. Although integrated systems may represent beneficial relationships that reduce resupply through synergistic uses of common resources, they may not improve reliability and/or maintainability performance factors.
- Assess the interrelationships of integrated systems that affect evolution of individual systems so that such evolution of one system is not significantly limited.

7.11 CONTRIBUTORS

Naresh Rohatgi (Co-Chair)
Michael Barrera
Scott Gilley
Mark Ballin

Bill Likens (Co-Chair)
P. K. Seshan
Matt Kolodney

Tony Kellicut
V. L. Wilson
R.C. Dalee

APPENDICES

A.	Detailed Agenda	43
B.	List of Workshop Participants	51
C.	Working Group Presentations	57

THIS PAGE INTENTIONALLY LEFT BLANK

APPENDIX A Detailed Agenda

PRECEDING PAGE BLANK NOT FILMED

dr

THIS PAGE INTENTIONALLY LEFT BLANK

**NASA OFFICE OF AERONAUTICS AND SPACE TECHNOLOGY
LIFE SUPPORT SYSTEMS ANALYSIS WORKSHOP
DETAILED AGENDA**

TUESDAY, 25 June 1991 - Host: Peggy L. Evanich, NASA Headquarters

8:00 - 8:20 1. Introduction and Overview

8:00 - 8:05 Workshop Agenda and Updates
Thomas M. Crabb - Orbital Technologies Corporation

8:05 - 8:20 Introduction and Overview of the NASA Life Support Systems Analysis Workshop
Peggy L. Evanich - NASA Headquarters

8:20 - 11:40 2. Overview of NASA Life Support Systems Analysis Capabilities/Tools

8:20 - 9:00 A. Advanced Life Support Systems Analysis Using CASE/A
Vincent J. Bilardo - NASA Ames Research Center

9:00 - 9:40 B. Rigorous Life Support Systems Analysis Methodology Using ASPEN PLUS
Dr. P. K. Seshan - Jet Propulsion Laboratory

9:40 - 10:20 C. Development of Physical-Chemical Life Support Hardware Scale-up Correlations
Dr. Naresh Rohatgi - Jet Propulsion Laboratory

10:20 - 10:40 **BREAK**

10:40 - 11:10 D. ASPEN Modeling of ECLSS Atmosphere Revitalization System (ARS) Subsystems
and Components
Dr. Chin H. Lin - NASA Johnson Space Center

11:10 - 11:40 E. Component-Level Modeling of Water Reclamation Processors
John W. Fisher - NASA Ames Research Center

11:40 - 12:00 3. Working Group Kickoff (Outline of Working Groups and Goals)

- Steady State and Dynamics Systems Analysis
- Modeling Validation and Scale-up Assessment
- Systems Analysis Evaluation Criteria
- Biological Systems Analysis
- Systems Integration Analysis

12:00 - 1:30 Luncheon Presentation

**Life Support Systems Strategies for Planetary Surface Systems
Barney B. Roberts - Johnson Space Center**

Workshop Coordinator: Tom Crabb - please contact with any questions or comments

44

NASA Life Support Systems Analysis Workshop

1:30 - 4:20 4. Analogous Systems Analysis Approaches/Tools

- 1:30 - 2:05 A. Scale-up Status and Concerns
 Dr. Attilio Bissio - ATRO ASSOCIATES
- 2:05 - 2:40 B. Scale-up and Verification in Chemical Process Systems Analysis
 Dr. W. Brian Bedwell - Allied Systems
- 2:40 - 3:15 C. Process Optimization for Steady State and Dynamic Modeling
 Dr. Lawrence Biegler - Carnegie Melon University

3:15 - 3:30 BREAK

3:30 - 5:30 5. Working Group Meeting #1 (in parallel)

- 5-1. Steady State and Dynamics Systems Analysis
- 5-2. Modeling Validation and Scale-up Assessment
- 5-3. Systems Analysis Evaluation Criteria
- 5-4. Biological Systems Analysis
- 5-5. Systems Integration Analysis

6:00 - 8:00 RECEPTION

Workshop Coordinator: Tom Crabb - please contact with any questions or comments

WEDNESDAY, 26 June 1991 - Host: Dr. P. K. Seshan, Jet Propulsion Laboratory

8:00 - 10:00 6. Software Demonstration Presentations

- 8:00 - 8:30 A. NASA Ames Research Center - CASE/A and spreadsheets
- 8:30 - 9:00 B. Jet Propulsion Laboratory - ASPEN Plus and spreadsheets
- 9:00 - 9:30 C. NASA Johnson Space Center - G189A and ASPEN Plus
- 9:30 - 10:00 D. NASA Marshall Space Flight Center - CASE/A for Space Station

10:00 - 10:15 BREAK

10:30 - 5:15 7. Software Demonstration (one on one discussions)

- 10:30 - 12:00 NASA/ARC CASE/A and spreadsheets
- 12:15 - 1:45 NASA/JSC G189A and ASPEN Plus
- 2:00 - 3:30 JPL ASPEN Plus and spreadsheets
- 3:45 - 5:15 NASA/MSFC CASE/A for Space Station

10:15 - 12:15 8. Life Support Applications of Systems Analysis

- 10:15 - 10:45 A. CASE/A Systems Analysis for Space Station
Allen S. Bacskay - NASA Marshall Space Flight Center
- 10:45 - 11:15 B. Integrated Model of G189A and ASPEN-Plus for the Transient Modeling of Life Support Systems
Matt Kolodney - Lockheed Engineering and Sciences Co.
Dr. Chin H. Lin - NASA Johnson Space Center
- 11:15 - 11:45 C. Analysis of an Initial Lunar Outpost Life Support Systems Preliminary Design
Mark G. Ballin, et.al. - NASA Ames Research Center
- 11:45 - 12:15 D. Systems Analysis of Mars Exploration Life Support
Joseph F. Ferrall - Jet Propulsion Laboratory

12:15 - 1:30 LUNCH (on your own)

Workshop Coordinator: Tom Crabb - please contact with any questions or comments

NASA Life Support Systems Analysis Workshop

1:30 - 3:50 9. Future Analysis Approaches and Evaluation Criteria

1:30 - 1:50

A. Integrated Power and Life Support Systems Analysis - ASPEN
Dr. Darrell Jan - Jet Propulsion Laboratory

1:50 - 2:20

B. Role of AI in Systems Engineering
Dr. Michael R. Fehling - Stanford University

2:20 - 2:40

C. Closing the Loop - CASE/A Extensions
Dr. Robert Sirko - McDonnell Douglas Corporation

2:40 - 3:00

D. Four-Component Strategy for CELSS Models: Diet, Crop Growth, Engineering, and Systems
Dr. Tyler Volk - New York University

3:00 - 3:10

BREAK

3:10 - 3:30

E. Decision Analysis: Technology Development for Lunar Base and SEI
Dr. Charles H. Simonds - Lockheed

3:30 - 3:50

F. Advanced Life Support Evaluation Tools
Thomas J. Slavin/Susan C. Doll - Boeing

3:50 - 6:00 10. Working Group Meeting #2 (in parallel)

- 10-1. Steady State and Dynamics Systems Analysis
- 10-2. Modeling Validation and Scale-up Assessment
- 10-3. Systems Analysis Evaluation Criteria
- 10-4. Biological Systems Analysis
- 10-5. Systems Integration Analysis

Workshop Coordinator: Tom Crabb - please contact with any questions or comments

THURSDAY, 27 June 1991

8:00 - 10:50 11. Working Group Presentations

- 8:00 - 8:20 A. Steady State and Dynamics Systems Analysis
- 8:20 - 8:40 B. Model Validation and Scale-up Assessment
- 8:40 - 9:00 C. Systems Analysis Evaluation Criteria
- 9:00 - 9:20 D. Biological Systems Analysis
- 9:20 - 9:40 E. Systems Integration Analysis

9:40 - 10:00 Break

10:00 - 10:45 12. Panel Review of Workshop Conclusions and Future Systems Analysis

- A. Vince Bilardo - NASA Ames Research Center
- B. P.K. Seshan - Jet Propulsion Laboratory
- C. Chin Lin - NASA Johnson Space Center
- D. Alan Basckay - NASA Marshall Space Flight Center

10:45 - 11:45 13. Overview of NASA's Life Support Technology Program

- 10:45 - 11:15 A. P-C Life Support Project Update
Vince Bilardo - NASA Ames Research Center
- 11:15 - 11:45 B. Lunar Base Life Support Test Bed
Al Behrend - NASA Johnson Space Center

Workshop Coordinator: Tom Crabb - please contact with any questions or comments

THIS PAGE INTENTIONALLY LEFT BLANK

APPENDIX B List of Workshop Participants

PRECEDING PAGE BLANK NOT FILMED

51

Workshop Proceedings

50

THIS PAGE INTENTIONALLY LEFT BLANK

Allen S. Bacskay
Code ED62, Bldg T285
NASA Marshall Space Flight Center
MSFC, AL 35812
(205) 544-0993

Mark G. Ballin
Code SAS, M/S 239-8
NASA Ames Research Center
Moffett Field, CA 94035
(415) 604-5771

Mr. Michael Barrera
Aspen Technology, Inc.
251 Vassar Street
Cambridge, MA 02139
(617) 497-9010

Dr. W.B. Bedwell
Allied Signal
50 E. Algonquin Rd
Des Plaines, IL 60017-5016
(708) 391-3500

Albert F. Behrend, Jr.
NASA Johnson Space Center
2101 NASA Road 1, CODE EC3
Houston, TX 77058
(713) 483-9241

Dr. Lawrence Beigler
MCS Division
Argon, IL 40439

Mr. Vincent Bilardo
Code SAS, M/S 239-8
NASA Ames Research Center
Moffett Field, CA 94035
(415) 604-5752

Dr. Attilio Bisio
ATRO Associates
Box 1367
Mountainside, NJ 07092
(908) 233-1524

Dr. Ray Bula
University of Wisconsin
1357 University Avenue
Madison, WI 53715
(608) 262-5526

Mr. Mel Cobb
Lockheed Missiles & Space Company
P.O. Box 3504, ORG 6N-12/B580
Sunnyvale, CA 94088-3504
(408) 756-6832

Ms. Carolyn Cooley
Martin Marietta Civil & Space Comm
P.O. Box 179, M/S DC8001
Denver, CO 80201
(303) 971-9375

Mr. Thomas M. Crabb
Orbital Technologies Corporation
402 Gammon Place, Suite 10
Madison, WI 53719
(608) 833-1992

Mr. Robert DaLee
McDonnell Douglas Space Systems Co
689 Discovery Drive, Mail Code 12C3
Huntsville, AL 35806
(205) 922-7320

Ms. Susan Doll
Boeing Aerospace Company
P.O. Box 240002, M/S JX-23
Huntsville, AL 35824-6402
(205) 461-3731

Dr. Alan Drysdale
McDonnell Douglas Space Systems
P.O. Box 21233
Kennedy Space Center, FL 32815
(407) 383-3819

Peggy L. Evanich
OAST, Code R
NASA Headquarters
Washington, DC 20546
(202) 453-2843

NASA Life Support Systems Analysis Workshop

Martha Evert
Lockheed/ESC
2400 NASA Rd 1, MC-C44
Houston, TX 77058
(713) 244-5111

Dr. Michael Fehling
Terman Engineering Center
Stanford University
Stanford, CA 94305-4025
(415) 723-0344

Mr. Joseph Ferrall
Jet Propulsion Laboratory
4800 Oak Grove Drive, M/C 125-224
Pasadena, CA 91109
(818) 354-3159

Mr. John Fisher
Code SAR, M/S 239-11
NASA Ames Research Center
Moffett Field, CA 94035
(415) 604-4400

Ms. Susan Fuhs
AIRResearch
P.O. Box 2960, M/S T-41
Torrance, CA 90509-2960
(213) 512-4600

Dr. Gani B. Ganipathi
Jet Propulsion Laboratory
4800 Oak Grove Dr, M/S 125-224
Pasadena, CA 91109
(818) 354-7449

Scott Gilley
Sverdrup Technology, NASA LeRC
21000 Brookpark Road, M/S 309-1
Cleveland, OH 44135
(216) 433-6137

Mr. Ian Gosling
Aspen Technology, Inc.
251 Vassar Street
Cambridge, MA 02139
(617) 497-9010

Mr. Stephen Gustavino
McDonnell Douglas Space Systems Co
5301 Bolsa Avenue, Mail Code 17-B
Huntington Beach, CA 92647
(714)896-3311

Mr. Joseph Homa
Hamilton Standard
One Hamilton Road, M/S 1A-2-W66
Windsor Locks, CT 06096
(203) 654-2495

Vibhor Jain
Bionetics Corporation
NASA Ames Research Center, MS 239-8
Moffett Field, CA 94035
(415) 604-1335

Darrell Jan
Jet Propulsion Laboratory
4800 Oak Grove Drive, M/C 125-224
Pasadena, CA 91109

Mr. Matthew Kolodney
Lockheed Engineering & Science Co
2400 NASA Road 1, M/C C70
Houston, TX 77058
(713) 333-7224

Mr. Richard Lamparter
NASA Ames Research Center
Mail Stop 239-11
Moffett Field, CA 94035
(415) 604-1159

Mr. William Likens
Code SAS, M/S 242-4
NASA Ames Research Center
Moffett Field, CA 94035
(415) 604-3210

Cheng-Hsiung Lin
Purdue University
Lorre/Potter Center, Rm 220
West Lafayette, IN 47907
(317) 494-7027

Dr. Chin Lin
NASA Johnson Space Center
2101 NASA Road 1
Houston, TX 77058
(713) 483-9126

Thomas M. Maloney
Sverdrup Technology, NASA LeRC
21000 Brookpark Road, M/S 309-1
Cleveland, OH 44135
(216) 433-6137

Dr. David Ollis
Chemical Engineering Department
North Carolina State University
Raleigh, NC 27695
(919) 737-2329

Dr. Firooz Rasouli
7449 N. Natchez Avenue
Niles, IL 60648-3892
(312) 647-9000

Mr. Barney Roberts
NASA Johnson Space Center
2101 NASA Road 1, Code IE2
Houston, TX 77058
(713) 283-5460

Dr. Naresh Rohatgi
NASA Jet Propulsion Laboratory
4800 Oak Grove Drive, M/S 125-224
Pasadena, CA 91109
(818) 354-3073

Dr. Willy Sadeh
Department of Civil Engineering
Colorado State University
Fort Collins, CO 80523
(303) 491-2001

Nelson Schlater
Bionetics Corporation
NASA Ames Research Center, MS 239-8
Moffett Field, CA 94035
(415) 604-1335

Dr. Richard Seagrave
Iowa State University
Sweeney Hall, Room 238
Ames, IA 50011
(515) 294-0518

Dr. P.K. Seshan
NASA Jet Propulsion Laboratory
4800 Oak Grove Drive, M/S 125-224
Pasadena, CA 91109
(818)354-7215

Dr. Charles Simonds
Lockheed Missiles and Space
1150 Gemini Ave, M/C A23
Houston, TX 77058
(713) 282-6203

Dr. Kamalesh K. Sirkar
Stevens Institute of Technology
Castle Point
Hoboken, NJ 07030
(201) 420-5432

Dr. Robert Sirko
McDonnell Douglas Space Systems Co
5301 Bolsa Avenue, Mail Code 13-2
Huntington Beach, CA 92647
(714) 896-3817

Mr. Thomas Slavin
Boeing Aerospace & Electronics Division
P.O. Box 3999, M/S 84-15
Seattle, WA 98124
(206) 773-1471

Mr. Paul Spurlock
S&A Automated Systems, Inc.
123 NW 13th Street, 13th Floor, Ste 222
Boca Raton, FL 33432
(407) 750-8786

Dr. Ted Tibbitts
University of Wisconsin
Room 327, Horticulture
Madison, WI 53706
(608) 262-1816

NASA Life Support Systems Analysis Workshop

Mr. William Trail
Aspen Technology, Inc.
251 Vassar Street
Cambridge, MA 02139
(617) 497-9010

Raymond B. Trusch
Hamilton Standard
One Hamilton Road
Windsor Locks, CT 06096
(203) 654-2495

Dr. George Tsao
Purdue University
Potter Building-1295
West Lafayette, IN 47907
(317) 494-7022

Dr. Tyler Volk
New York University
26 Stuyvesant Street
New York, NY 10003
(212) 998-8995

Raymond M. Wheeler
NASA Kennedy Space Center
Code MD-RES
Kennedy Space Center, FL 32899
(407) 853-5142

Dr. Lionel R. Whitmer
Boeing Missiles and Space Division
P.O. Box 240002, M/S JR-34
Huntsville, AL 35824-6402
(205) 461-5854

Mr. Versie L. Wilson
Boeing Missiles and Space Division
P.O. Box 240002, M/S JR-34
Huntsville, AL 35824-6402
(205) 461-5822

Dr. Bruce Wright
Boeing Missiles and Space Division
499 Boeing Blvd, M/S JR-34
P.O. Box 240002
Huntsville, AL 35824-6402
(205) 461-5822

WORKING GROUP SUPPORT

Anthony J. Kellicutt (Orbital Technologies Corporation)
Darin R. Kohles (Orbital Technologies Corporation)
Janis M. Moths (Orbital Technologies Corporation)
Dr. Thomas L. Woodzick (Orbital Technologies Corporation)

WORKSHOP SUPPORT

Marcia McDevitt (General Research Corporation)
Marie L. Davis (Orbital Technologies Corporation)

APPENDIX C Original Working Group Presentations

- C.1 Working Group 1: Steady State and Dynamics Systems Analyses
- C.2 Working Group 2: Modeling Validation and Scale-Up Assessment
- C.3 Working Group 3: Systems Analysis Evaluation Criteria
- C.4 Working Group 4: Biological Systems Analysis
- C.5 Working Group 5: Systems Integration and Analysis

THIS PAGE INTENTIONALLY LEFT BLANK

WORKING GROUP PARTICIPANTS

Steady State and Dynamics Systems Analyses

Chair: P.K. SESHAN, Jet Propulsion Laboratory (818) 354-7215		
NAME	AFFILIATION	PHONE
Mark Ballin	NASA ARC	415/604-5771
Michael Barrera	Aspen Technologies	617/494-9010
Vincent Bilardo	NASA ARC	415/604-5752
Thomas M. Crabb	ORBITEC	608/833-1992
Robert DaLee	McDonnell Douglas	205/922-7320
Joseph Ferrall	JPL	818/354-3159
John Fisher	NASA ARC	415/604-4400
Scott Gilley	Sverdrup	216/433-6137
Matthew Kolodney	Lockheed	713/333-7224
P.K. Seshan	JPL	818/282-6203
William Trail	Aspen Technologies	617/494-9010

THIS PAGE INTENTIONALLY LEFT BLANK

WORKING GROUP: STEADY STATE AND DYNAMIC SYSTEMS ANALYSES

ISSUES IDENTIFIED: Need for additional generic modules in simulation software packages

OBSERVATIONS: ASPEN Plus and CASE/A have many modules, not always generic in the case of CASE/A. However, some modules needed for life support systems are not built in. ASPEN Plus provides for custom building of new modules. The names of many of the LS process units and unit operations are not generic but could be expressed in terms of one or more built-in generic modules of software packages.

RECOMMENDATIONS: Generic modules needed:

- Electrochemical reactor
- Ion exchange
- Membrane Separator
- Plant
- Metabolic man/woman
- Kitchen
- Dishwasher
- Clothes washer
- Clothes drier
- Toilet
- Shower
- Metabolic animal
- Bioreactors(various kinds)

Specific module needed:

More rigorous VCD model for CASE/A

On module development by users:

- Agree on module structure/interfaces
- Share modules and avoid duplication of effort

CONTRIBUTORS: John Fisher, Tom Crabb, Joe Ferrall, Michael Barrera, P. K. Seshan

WORKING GROUP: STEADY STATE AND DYNAMIC SYSTEMS ANALYSES

ISSUES IDENTIFIED: Need for rigorous dynamic simulation in life support systems analysis

OBSERVATIONS: CASE/A,G189A,SPEEDUP and SIMTOOL have combined steady state and dynamic simulation capabilities. ASPEN Plus can simulate transient performance of individual blocks by the using RBATCH and custom code modules capable of executing sophisticated integration algorithms.

CASE/A and G189A do not contain the standard tools for control system analysis (analysis of performance dynamics). MATRIX, System Build and MATLAB are control system design/analysis packages. However, they are not chemical process simulation packages. Only one commercial chemical process simulator, SPEEDUP by Prosys Technology, can simulated dynamics within a block and across an entire flow sheet using sophisticated integration methods, but probably not very user friendly.

Rigorous dynamic simulations are needed for system response and controllability studies, for control system design and testing and not for systems analysis. Rigorous dynamic simulations are not needed during conceptual system studies and technology development. They have little relevance to system parameters such as weight, volume, power demand etc.

RECOMMENDATIONS: Quasi-steady state simulation capability in ASPEN Plus particularly to monitor changes in storage tanks.

Rigorous dynamic simulations must be part of the design review process especially for transient thermal response of process equipment including highly exo/endermic chemical reactors.

Since early concept definition must also include definition of control strategies, use dynamic simulations even at the conceptual stage.

CONTRIBUTORS: V. L. Wilson, Scott Gilley, Michael Barrera, John Fisher, Joe Ferrall, Matt Kolodney, Tom Crabb, P. K. Seshan

WORKING GROUP: STEADY STATE AND DYNAMIC SYSTEMS ANALYSES

ISSUES IDENTIFIED: Experimental and other data to be delivered by technology developers to support systems analysis

OBSERVATIONS: Component and subsystem packaging may have an important effect on the ability to scale up weight and volume. Data pertaining to the optimal performance state of a component alone will not be adequate since system-wide optimum performance may necessitate suboptimal performance of a component.

RECOMMENDATIONS: Performance data relating to failure modes and failure of one of two or more redundant items. Separate weight, volume etc. measurements of individual process units, instruments, wiring, plumbing, fittings, support structures, insulation/lagging and any other packaging materials/structures. Both basic data such as kinetic rate constants and equilibrium constants for reactions as well as hardware dependent data such as flow rates, power demand etc. Operating conditions such as temperature, pressure, feed concentrations etc. as well as performance parameters such as percent conversion/separation. All the above data for different sizes of the process equipment. Operating envelope and performance data a little outside the operating envelope.

All technology development proposals must contain a section on scaleup detailing approaches and deliverables to enable scaleup. All technology development proposals must be reviewed by system analysis personnel with experience in process simulation and equipment scaleup. Their recommendations must be made part of the contract deliverables.

CONTRIBUTORS: Joe Ferrall, Matt Kolodney, Michael Barrera, John Fisher, R. C. Dalee, P. K. Seshan

- WORKING GROUP:** **STEADY STATE AND DYNAMIC SYSTEMS ANALYSES**
- ISSUES IDENTIFIED:** Property data for trace contaminant control modeling
- OBSERVATIONS:** ASPEN Plus contains a large database and can calculate properties based on molecular structure and can track trace chemicals in the model by setting extremely tight tolerances on convergence.
- Trace contaminants such as methane and carbon monoxide may also affect the life cycle and size of the Bosch unit and must be accurately accounted for.
- RECOMMENDATIONS:** Obtain kinetic data for trace contaminants not found in the ASPEN Plus database, either through literature search or through experiments. Since possible contaminants are too numerous to model and track in a any simulation, organize them into not more than ten classes and select a representative compound for each class for modeling trace contaminant processes in life support systems
- CONTRIBUTORS:** Joe Ferrall, Matt Kolodney, R. C. Dalee, Michael Berrara, John Fisher, P. K. Seshan

WORKING GROUP: STEADY STATE AND DYNAMIC SYSTEMS ANALYSES

ISSUES IDENTIFIED: Effect of micro/partial gravity on thermodynamic, transport and kinetic properties

OBSERVATIONS: Several contractor and NASA reports available on the subject of the effect of microgravity covering components and subsystems that are and aren't affected. LESC '90 report includes many of the governing equations. Gravity affects transport processes; thermodynamic properties are not expected or known to be affected by the magnitude of gravity. Finely divided particles, bubbles and droplets could exhibit gravity dependence on equilibrium properties due to high surface energy; however, these are often avoided in microgravity environments due to phase separation problems. Often life support processes are likely to be designed to be independent of the gravity environment or generate their own gravitational fields.

RECOMMENDATIONS: Conduct a workshop of experts in properties measurements to identify potential experiments to be conducted in microgravity environments to generate a microgravitational property database of interest to life support systems.

Retrofit a KC-135 type aircraft with an automatic trajectory control system to minimize gravity and maximize duration in low gravity to conduct reproducible property measurement experiments.

Plan, establish and fund a program of chemical and physical properties measurements on the SSF.

CONTRIBUTORS: Matt Kolodney, R. C. Dalee, Tom Crabb, Mark Ballin, Joe Ferrall, Michael Barrera, P. K. Seshan

THIS PAGE INTENTIONALLY LEFT BLANK

WORKING GROUP PARTICIPANTS

MODELING VALIDATION AND SCALE-UP ASSESSMENT

CHAIR: CHIN LIN, NASA Johnson Space Center (713) 483-9126		
NAME	AFFILIATION	PHONE
W.B. Bedwell	Allied Signal	708/391-3463
Mel Cobb	Lockheed	408/756-0261
Vibhor Jain	NASA Ames	415/960-9477
Darin Kohles	ORBITEC	608/833-1992
Chin Lin	NASA JSC	713/483-9126
David Ollis	N. Carolina State	919/737-2329
Firooz Rasouli	Chamberlain Gard	708/647-3244
Kamalesh K. Sirkar	Stevens Institute	201/420-5432
Versie L. Wilson	Boeing	205/461-5822

PRECEDING PAGE BLANK NOT FILMED

66
6/10/73

THIS PAGE INTENTIONALLY LEFT BLANK

Modeling Validation and Scale-Up Assessment Working Group

PROTOTYPE AND TEST BED REQUIREMENTS

RECOMMENDED APPROACH:

- Build and Test Prototypes at Incremental Levels up to No Less than $\frac{1}{4}$ of Flight Hardware
 - ▶ Different Missions may Require Different Levels of Prototype
- Need Test Beds at Both Component and Integrated System Levels

PRECEDING PAGE BLANK NOT FILMED

Modeling Validation and Scale-Up Assessment Working Group

DATA COLLECTION REQUIREMENTS

RECOMMENDED APPROACH:

- Continue Expansion and Enhancements of the Existing Centralized Database to Incorporate all Hardware and Test Data Relevant to Modeling/Analysis
- Make a Commitment to Acquire the Necessary Data for Model Validation and Scale-Up
 - ▶ Establish a Generalized Protocol for Defining Test Requirements for System Analysis
 - Modeling/Analysis Provides Influential Inputs to Test Requirements
 - Modeling/Analysis Provides Pre-Test Prediction
 - Modeling/Analysis Uses Test Data to Correlate Models
 - ▶ Provide Sufficient Resources to Hardware Testing Program to Obtain In-Depth Measurements Over Wider Ranges

Modeling Validation and Scale-Up Assessment Working Group

SCALE-UP OF PROTOTYPE/TEST BED

RECOMMENDED APPROACH:

- Use Test Data at Component Level to Support Scale-Up of Individual Component, Rather than Doing Scale-Up at a Subsystem or System Level
- Broaden Use of Validated Models/Analysis for Hardware Scale-Up
- Use More Dimension Analysis and Similitude Analysis to Support Scale-Up

Modeling Validation and Scale-Up Assessment Working Group

EFFECTS OF MICROGRAVITY AND PARTIAL GRAVITY

RECOMMENDED APPROACH:

- Re-Examine the Governing Equations Used in Current Models. Make Sure that G is Justifiably Negligible
- Perform a Thorough Study to Identify Gravity-Sensitive Processes and Test Requirements for New and Emerging Life Support Technologies
- For Gravity-Sensitive Process, Perform Ground Tests or Flight Experiments to Ascertain Gravity Effects
 - ▶ Centrifuge for Partial Gravity
 - ▶ KC-135, Shuttle and Station-Bases Tests for Microgravity

Modeling Validation and Scale-Up Assessment Working Group

VALIDATION TEST SERIES

RECOMMENDED APPROACH:

- Use Rigorous Experiment Design Techniques to Maximize Return of Necessary Testing
- For an Agency-Wide Group, Including Industry and Academia, Formulate a Consistent and Comprehensive Testing Strategy

Modeling Validation and Scale-Up Assessment Working Group

PROTOTYPE AND TEST BED REQUIREMENTS

ISSUE: What Types of Hardware and Test Beds will be Required for Model Validation and Scale-Up?

CURRENT STATUS:

- Most Hardware Data for Existing Life Support Technology are Known at:
 - Bench-Top (Bread Board) or Pre-Prototype Level
 - One Size Design
- Test Beds Only Exist at Component and Subsystem Levels
- Integrated System-Level Test Beds, with Prototype H/W, are in Planning

Modeling Validation and Scale-Up Assessment Working Group

DATA COLLECTION REQUIREMENTS

ISSUE: Are Hardware and Test Data Being Collected, Reported, and Organized in an Efficient Manner to Support Model Validation and Scale-Up?

CURRENT STATUS:

- A Centralized Life Support System Technology Database has been established at Ames Research Center.
 - Completeness?
- Substantial P/C Technology Data have been Collected by Boeing; Bioregenerative Technology Data by LMSC
 - Accessibility?
- Lack of Detail Break-Down Hardware Data at Part Level to support Validation of Scale-Up Correlation
- Incomplete Fundamental "Driving Mechanism" Data to Support Validation of System Performance Model
- Component- and Subsystem-Level Test Data are Rather Limited in Range and Number of Parameters

Modeling Validation and Scale-Up Assessment Working Group

SCALE-UP OF PROTOTYPE/TEST BED

ISSUE:

- What Analysis Techniques Should Be Used?
- Are Available Data Adequate?
- How to coordinate Modeling/Analysis with Hardware Scale-Up

CURRENT STATUS:

- Prototype/Test Bed Data Mostly Exist at a Capacity Up To 4-Man. This is not Adequate to Accurately Scale-Up a Subsystem to a Larger Capacity Level (>16-Man)
- Test Data are Not Usually Collected to Support Scale-Up Assessment
- Dimension and Similitude Analysis Techniques have been Used, but Not Across-the-Board
- Hardware Scale-Up and Modeling/Analysis are Often Conducted in Parallel and Independently

Modeling Validation and Scale-Up Assessment Working Group

EFFECTS OF MICROGRAVITY AND PARTIAL GRAVITY

ISSUE: How to Validate Models and Scale-Up Analysis for Life Support System in a Micro- or Partial-Gravity Environment

CURRENT STATUS:

- Gravity is Not an "Explicit Parameter"
- Models and Analysis are Validated with Earth-Based Ground Test Data
- Independent Studies have been Performed to Identify Processes in Life Support Systems which are Sensitive to Gravity
- Some Components and Subsystems have been Tested in Different Orientation on Earth to Drive Out Gravity Effects
- Shuttle- or Space Station-Based Flight Experiments have been Planned/Proposed to Ascertain Gravity Effects.

Modeling Validation and Scale-Up Assessment Working Group

THIS PAGE INTENTIONALLY LEFT BLANK

WORKING GROUP PARTICIPANTS SYSTEMS ANALYSIS EVALUATION CRITERIA

CHAIR: ALLEN BACSKAY, NASA Marshall Space Flight Center (205) 544-0993		
NAME	AFFILIATION	PHONE
Allen Bacskay	NASA MSFC	205/544-0993
Susan Doll	Boeing Aerospace	205/461-3731
Alan Drysdale	MDSSC-KSC	407/383-3819
Martha Evert	Lockheed	713/244-5111
Joe Homa	Hamilton Standard	203/654-3890
Willy Sadeh	Colorado State U.	303/491-2001
Nelson Schlater	Bionetics	415/604-1335
Charles Simonds	Lockheed	713/282-6803
Paul Spurlock	S&A Automated Sys	407/750-8786
Thomas L. Woodzick	ORBITEC	608/833-1992

PRECEDING PAGE BLANK NOT FILMED

THIS PAGE INTENTIONALLY LEFT BLANK

Systems Analysis Evaluation Criteria Working Group

RECOMMENDATIONS:

- Relate Criteria To Single Accountable Unit
 - ▶ Take Away Subjective Decision Making
- Set Up Working Group Meeting with All Environmental Control Life Support System (ECLSS) Disciplines to Define Issues
 - ▶ Issues Vary Depending on ECLSS Function
- Distribute Current Evaluation Criteria to All Participants Prior to Meeting
- Result of Meeting to be Mutually Accepted Method for Evaluation Independent of Mission Type/Duration

PRECEDING PAGE BLANK NOT FILMED

80

Systems Analysis Evaluation Criteria Working Group

WORKING GROUP GOAL:

- Criteria Definition
 - ▶ Levels of Detail

OVERVIEW OF DISCUSSION:

- Day 1
 - ▶ Accomplishments
 - Criteria Definition (System Level)
- Day 2
 - ▶ Restructure Working Group Goal
 - ▶ Definition of Strategies
 - Decision Analysis
 - Lockheed Space Exploration Initiative Manual

Systems Analysis Evaluation Criteria Working Group

MODEL EVALUATION CRITERIA

GOAL: Define Clear Objective Criteria which can be Applied to Diverse Options (e.g., Physicochemical with Supplied Food vs. Bioregenerative)

- Should Roll Up From Components to Subsystems to Systems, etc.
- Applicable to All Missions

RECOMMENDATIONS:

- Analyses must be Based On Objective, Testable Requirements
- Models must be Able to Predict Outputs for All Requirements, Within Necessary Accuracy
- All Criteria must be Reduced To Common Units. Binary Decision (Meet Requirements/Not) and Cost
- The Recommended Criteria is Life Cycle Cost. This can be Used As the:
 - Program Criteria
 - Architecture Criteria
 - System Criteria
 - Subsystem Criteria
 - Component Criteria

Care Must Be Taken to Ensure All Cost Discriminators have been Included

- Sub-Elements of Life Cycle Cost Include:
 - Mass Delivery Cost
 - Power and Cooling Cost
 - DDT&E Cost
 - Manpower Cost-Crew Time
 - Resupply Cost
 - Scarring
 - Volume
 - Cost of In-Situ Resources

Systems Analysis Evaluation Criteria Working Group

LIFE CYCLE COST (LCC)

ADVANTAGES

- Common Unit: Implicitly Supports Mass/Power Trade-Offs
- Applicable To Any Objective Requirement/Resource
- Forces Program To Make Assumptions Explicit -- Cost is As Important As Performance
- Can be Used From Program To Program
- Can be Used Throughout Program, Accuracy Growing as Program Proceeds from Phase A, Phase B, Phase C/D, and Into Operation

DISADVANTAGES

- Political/Programmatic Sensitivity to Cost
- Uncertainty Associated With Some Requirements Such As Safety, Reliability
- Existing DOD LCC Estimation Methods/Tools must be Used With Caution as they are Designed for Support of Systems Involving Many Units (e.g., 960 F-16s). There are only Four Shuttles, One Space Station

Systems Analysis Evaluation Criteria Working Group

STANDARD INPUTS TO ARCHITECTURE AND SYSTEM-LEVEL EVALUATION MODELS

- Mission Parameters, e.g.:
 - ▶ Crew Size (4)
 - ▶ Duration (90 days)
 - ▶ Location (Lunar Surface)
- Top Level Performance of Other Systems, e.g.:
 - ▶ Cost of Mass Delivery to Point of Use (Moon Surface) (\$ per pound) (50K)
 - ▶ Cost of Power at Point of Use (\$ per Kilowatt-Hour)
 - ▶ Cost of Crew Time at Point of Use (\$ per Man-Hour)
 - ▶ Cost of Lunar Oxygen (\$ per pound)
- Absolute and/or Allocated Resource Limits, e.g.:
 - ▶ Maximum Average Use of Crew Time = 1 person out of Crew of 4
- Standards to be Used, e.g., JSC STD 3000
- Requirements to be Met, e.g.:
 - ▶ Use of Space Shuttle for Delivery of Space Station to Orbit

Systems Analysis Evaluation Criteria Working Group

RECOMMENDED METHODOLOGY

- Establish Requirements Including Safety, Reliability
- Develop Scenario and Design to Meet Requirements - Several Options
- Develop Life Cycle Cost for Each Option
- Identify Drivers for Interfaces With Other Systems, e.g., Unusual Duty Cycles, Mass Requirements/Surplus

System Analysis Evaluation

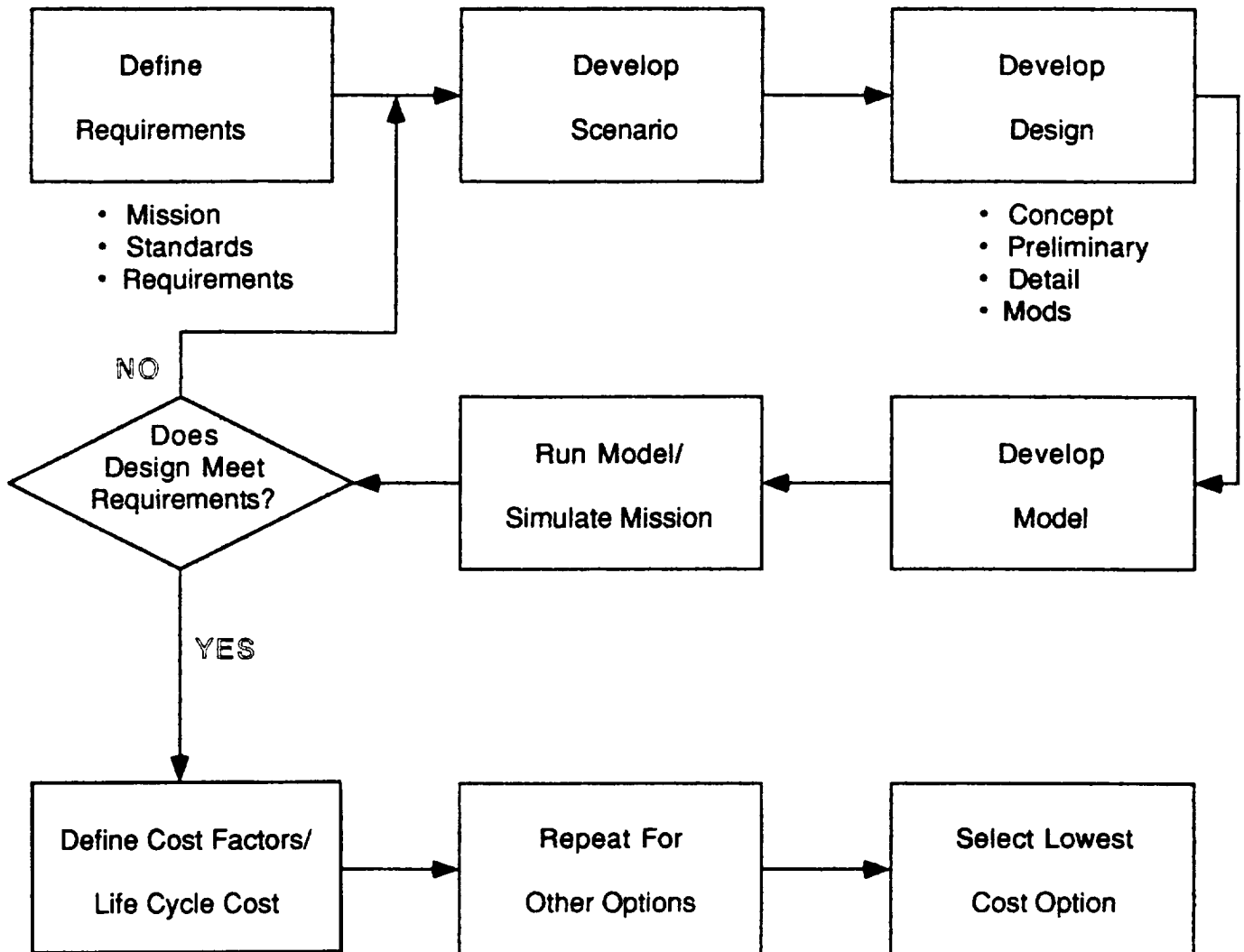

Systems Analysis Evaluation Criteria Working Group

Life Cycle Cost

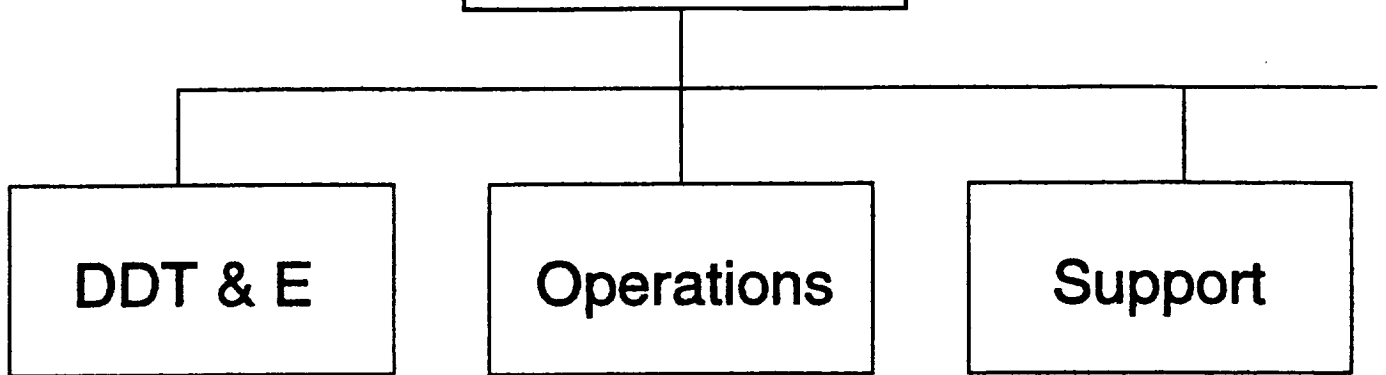

- Design Cost
- Fabrication Cost

(Depends on #)
(Mass, Complexity,
Technology Readiness,
Requirement vs. SOA)

Concept Definition
Phase A

Concept Development
(Prelim Design) Phase B

Detail Design
Phase C/D

Operations
Phase O

Operations

- Operations Cost

(Mass, Delivery Cost,
Power, Power Cost,
Manpower, Manpower
Cost, Consumables Cost)

- What is the ROM Cost of Architecture Options? Run system model and derive mass, power, etc.
- What is ROM Cost of System/Subsystem Options? Run subsystem model, derive mass, power, etc. Derive ROM 1/F characteristics.
- What is performance of Design? Run model to verify design compliance.
- What is cost of design changes? Run model of change, verify design compliance, estimate delta cost.
- What is most likely cause of problem? Simulate potential problems. Did model predict actuals? Try out mods. Verify design compliance, estimate cost.
- What are impacts of proposed changes?

Support

- Maintenance/Maintainability
- Repair
- Refurbishment
- Support Cost

(Resupply Mass, Crew
Time, Support Equipment
Mass, Volume, Power)

Systems Analysis Evaluation Criteria Working Group

SYNOPSIS

KEY ISSUES:

- Disorganization of Judgment
- Decisions Must Be Made Today Without Knowing Precisely What the Mission Will Be and Consequently What Problems Need to be Solved
- Decisions Which Look Good on the Surface Can Actually be Seriously Misguided Without Having All Interests Well Understood
- "If You Can't Identify What You Want, the Results of Your Analysis Will be Meaningless"

PRESENT METHODOLOGY TO ADDRESS ISSUES

- A Well-Validated and Structured Methodology has been Developed in the Decision Analysis Community for Making Strategic Decisions. This exists in Several Areas of Industry and Private Sector

RECOMMENDATIONS

- Establish Workshop with Various Interested Groups, Experts, etc., to Produce a More Coherent View of the Issues at Hand
 - ▶ Provide Background Info to Workshop Participants to Allow Preparation
 - ▶ Make Individuals "Mix It Up" to Find a Way to Raise It Above the Ground and Develop Compromises
 - ▶ Identify and Suggest Industrial Methodologies for Strategic Decision Analysis (at the Workshop)
- Establish a Set of Evaluation Standards (Perhaps)

Systems Analysis Evaluation Criteria Working Group

EVALUATION CRITERIA AND ITS WEIGHTING

ISSUE:

Evaluation criteria identified as critical at the "subsystem" level may be misrepresented or overweighted when all subsystems are compared at the "system" level (example: if an evaluation criterion should be de-weighted by all subsystem analysis efforts). Listing criteria by system, subsystem and processor could be extremely misleading unless system-level data is available in order to help determine the weighting factors--if system level data changes, the individual evaluation criterion's weighting would need to be changed.

RECOMMENDED APPROACH:

- Decide Level to be Evaluated:
 - ▶ System Level - "Best" Life Support System for a Particular Application
 - ▶ Subsystem Level - Which Technology Does a Better Job of Recycling Water?
- Examine List of Criteria and Define Terms
- Make Recommendation to Develop "Common Units" to Compare Power, Mass, Volume
- Recommend that a Process and Standard Set of Evaluation Criteria be Adopted by NASA and Used by the Life Support Community

Systems Analysis Evaluation Criteria Working Group

WORKING GROUP PARTICIPANTS Biological Systems Analysis

Chair: RAYMOND M. WHEELER, NASA Kennedy Space Center (407) 853-5142		
NAME	AFFILIATION	PHONE
Ray Bula	Univ of Wisconsin	608/262-5526
Carolyn Cooley	Martin Marietta	303/971-9375
Alan Drysdale	McDonnell Douglas	414/821-0903
Gani B. Ganapathi	JPL	818/354-7449
Ian Gosling	Aspen Technology	617/494-9010
Stephen Gustavino	McDonnell Douglas	714/896-3311
Janis Moths	ORBITEC	414/821-0903
Dick Seagrave	Iowa State Univ	515/294-0518
Robert Sirko	McDonnell Douglas	714/896-3817
Ted Tibbitts	Univ of Wisconsin	608/262-1816
George T. Tsao	Purdue University	317/494-7022
Tyler Volk	New York Univ	212/998-8995
Raymond Wheeler	NASA KSC	417/853-5142
Bruce Wright	Boeing	205/461-5822

Systems Analysis Evaluation Criteria Working Group

THIS PAGE INTENTIONALLY LEFT BLANK

Biological Systems Analysis Working Group

PRIMARY PRODUCTION

ISSUE: Availability of Data for Primary Production from Biological Systems (i.e., plant and/or algae growth and productivity)

CURRENT STATUS:

- Food/Biomass Production -- Good/Extensive Data
- H₂O Transpired (Distilled) -- Extensive Data
- CO₂ Removed
 - ▶ Some Direct Measurements (e.g., Kennedy Space Center Biomass Production Chamber [BPC])
 - ▶ Extensive Data from Biomass Calculations
- O₂ Produced
 - ▶ Few Direct Measurements (e.g., KSC BPC)
 - ▶ Can be Estimated From Biomass Production Data
- Extensive Environmental Response Data (but not all conducive to response surface analyses).
- Contaminants -- Very Little Data (Trace)
- Gravitational Effects -- Very Little Data

Biological Systems Analysis Working Group

WASTE TREATMENT/RESOURCE RECOVERY

ISSUE: Availability of Waste Treatment/Resource Recovery Data from Biological Systems

CURRENT STATUS:

- Cellulose Conversion -- Limited Data/Bench-Top Level
- Aerobic Treatment Systems -- Little Data
- Anaerobic Treatment Systems -- Even "Less" Data
- Biomass Leaching to Recover Minerals -- Limited Data
- Aquaculture/Animal Systems for Conversion of Inedible Biomass -- Limited Data
- Gravitational Effects on Biological Waste Treatment Systems -- No Data Available

NOTE: Commercial Technologies and Data Available from Systems with Aerobic/Anaerobic Treatment (e.g., Sewage Treatment Plants)

Biological Systems Analysis Working Group

ENERGY REQUIREMENTS

ISSUE: Availability of Energy Requirements for Biological Systems for Life Support

CURRENT STATUS:

- Plant Lighting -- Good Data on Irradiance Levels Which Can be Used to Calculate Connected Power Requirements
- Heating, Ventilation and Air Conditioning (HVAC) -- Few Data from Direct Measurements, but Good Estimates Should be Obtainable
- Water Pumping -- Again, Few Direct Measurements, but Estimates are Easily Obtainable. This Will Be Much Less than Lighting/HVAC Requirements
- Waste Treatment Systems -- Few Data Available on Biological Systems as Applied for Human Life Support

Biological Systems Analysis Working Group

MASS REQUIREMENTS

ISSUE: Mass Requirements for Biological Systems for Primary Production and Waste Treatment

CURRENT STATUS:

- Plant Culture System
 - ▶ Few Data Reported, but Should be Obtainable
 - ▶ Good Data on Area/Volume Requirements (e.g., Crop Productivity) Which Should Ultimately Dictate System Mass Requirements

- Biological Waste Treatment/Resource Recovery
 - ▶ Few Data Available
 - ▶ Some Data on Water Volume/Mass Requirements for Aquaculture Systems for Conversion of Inedible Biomass

Biological Systems Analysis Working Group

PROBLEM: Lack of Consistent Approaches for Biological Life Support System Testing

RECOMMENDED APPROACH:

- Define Critical Inputs and Outputs and Controlling Factors
- Consider Response Surface Approaches, Rather Than merely Defining Optimum Levels
- Employ Statistical Tools to Handle Variability

NOTE: The Above Should Apply to Both Primary Production Systems (i.e., Plants or Algae) and Waste Management and Resource Recovery Systems

Biological Systems Analysis Working Group

PROBLEM: Lack of Data on Use of Biological Systems for Waste Management

RECOMMENDED APPROACH:

- Establish the Mass, Power, and Volume Requirements for the operation of Biological Waste Treatment Systems
- Initiate Testing of Various Biological Waste Treatment and Resource Recovery Systems to Generate Data Useful in Modeling System Operation

Biological Systems Analysis Working Group

PROBLEM: Lack of Human Behavior Data with regard to Presence or Absence of Plants

RECOMMENDED APPROACH:

- Conduct Extensive Literature Search for Human Response/Behavior Studies Assessing the Benefits or Problems of Having Plants Nearby and/or Benefits from Engaging in Horticultural Activities
- Initiate Studies of Human Response and Behavior in Living and Working Areas With and Without Plants, I.e., Psychological Benefits Studies
- Factor Results from Literature and/or Surveys into Modeling Approaches Assessing the Advantages of Different Life Support Systems

Biological Systems Analysis Working Group

PROBLEM: Lack of Information of Biological System Operations under Microgravity

RECOMMENDED APPROACH:

- Initiate Testing Program to Characterize Operation and Productivity of Biological System (Especially Plant Production Systems) Under Microgravity, Through Flight Experiments

Biological Systems Analysis Working Group

PROBLEM: Lack of Data on Animal Systems for Use in Waste Management

RECOMMENDED APPROACH:

- Initiate Survey of Possible Animal (i.e., Other Than Microbiological) Options to Use for Waste Conversion. Possible Options might include Fish, Poultry, and/or Insects to Convert Inedible Plant Biomass and Provide a Protein Supplement for Humans.
- Assess the Advantages and Disadvantages to Each

Biological Systems Analysis Working Group

PROBLEM: Lack of Long-Term, Large-Scale Test Data

RECOMMENDED APPROACH:

- Initiate/Continue Large-Scale Studies to Assess Scale-Up Problems for Biological Systems
- Initiate Long-Term Studies to Assess Performance of Biological Systems Over Time

Biological Systems Analysis Working Group

ANCILLARY SUGGESTIONS:

- Identify Power, Mass and Volume Requirements for Plant Cultural Activities, Harvesting, and Food Processing
- Develop a Generic Repository for Biological Systems Data for Use in a Standard Modeling Approach

Biological Systems Analysis Working Group

THIS PAGE INTENTIONALLY LEFT BLANK

WORKING GROUP PARTICIPANTS

Systems Integration

Co-Chair: NARESH ROHATGI, Jet Propulsion Laboratory, 818/354-3073 Co-Chair: BILL LIKENS, NASA Ames Research Center, 415/604/3210		
NAME	AFFILIATION	PHONE
Vince Bilardo	NASA Ames	415/604-5752
Susan Fuhs	AiResearch	213/512-4600
Darrell Jan	JPL	818/354-4542
Tony Kellicut	ORBITEC	608/833-1992
William Likens	NASA Ames	415/604-3210
Robert Lin	Purdue University	317/494-7027
Thomas M. Maloney	Sverdrup	216/433-6137
Eric Rice	ORBITEC	608/833-1992
Naresh Rohatgi	JPL	818/354-3073
Thomas Slavin	Boeing	206/773-1471
Raymond B. Trusch	Hamilton Standard	203/654-2495

System Integration and Analysis Working Group

KEY PROBLEM AREAS

- Physical Interfaces
 - ▶ Identification of Material Interactions, Technologies for Effecting Beneficial Interactions (see note)

- Integration Process
 - ▶ Standards: Materials, Commonality, Interfaces
 - ▶ Reliability and Risk Dependencies

NOTE: Chosen to be the current focus of the working group.

System Integration and Analysis Working Group

X LSS Related Dependency

X Possible Further Dependency

? Other non - LSS Dependencies

\ Provides Support / Receives Support	Power	Thermal	EVA	In-situ Resources	Propulsion	Laboratory	Construction & Manufacture	ECLSS
Power	-	X		X		X	X	X
Thermal	X	-		X		X	X	X
EVA			-	X				
In-situ Resources				-	X			X
Propulsion			X		-			?
Laboratory						-		
Construction & Manufacture							-	
ECLSS	?	?	X		?			-

N² DEPENDENCY MATRIX An Approach to Bounding the Problem

System Integration and Analysis Working Group

ISSUES ADDRESSED:

- Power/Thermal System Integration
- Propulsion System Integration
- In-Situ Resource Utilization Integration
(Lunar and Mars Habitats)
- Laboratory Systems
- Construction and Manufacturing
- Extravehicular Activity (EVA) and Base Vehicles
- Existing Software

System Integration and Analysis Working Group

POWER

- Regenerative Fuel Cell
 - ▶ Alkaline, Proton Exchange
 - ▶ Development: Advanced, Could be Flight-Ready in Five Years
 - ▶ Uses Fluids Common with Life Support Systems: H_2O , O_2 , H_2
 - Possibilities for Common Hardware, Storage, Resource Sharing

- Other Power Technologies
 - ▶ Solid Oxide Fuel Cell (~10 Years Until Development)
 - ▶ Nuclear
 - ▶ Photovoltaic

System Integration and Analysis Working Group

THERMAL

- Heating and Cooling
 - ▶ Heat Pipes, Heat Pumps, Radiator
 - ▶ Flight Ready
 - ▶ May Have Common Working Fluids (Water)
- High Efficiency Radiators
- Thermal Storage
 - ▶ Sublimation of CaF, LiF
 - ▶ Lab-Scale Development (~10 Years until Development)
 - ▶ Common Working Fluid (Water?)
- Possibilities for Common Interaction
 - ▶ Water Sharing, Shared Storage, Air

System Integration and Analysis Working Group

PROPULSION

- Liquid H₂O, O₂, H₂
 - ▶ Possibility for Resource Sharing, Common Storage
- Hydrazine Propulsion
 - ▶ N₂H₄ Decomposition into N₂, H₂ a Possible Source of Resource Usable by Life Support Systems
- Electric Propulsion -- Ion, Arcjet, Magnetodynamic Development: Advanced for Ion, Arcjet
 - ▶ Life Support System Gases (H₂, CH₄, etc.) Could be used as Propellant
- Other: Fusion Rockets, Nuclear Thermal Propulsion
- Common Material: H₂ Propellant?

System Integration and Analysis Working Group

IN-SITU RESOURCES

- O₂ Generation from Lunar Regolith, Mars CO₂, Mars Ice
- H₂O Concentration for Plant Support, O₂ and H₂O Production
- CO₂ Concentration for Plan Support, O₂ and H₂O Production

DEVELOPMENT STATUS: Very Immature, Conceptual

- Possible Overlap with Life Support Systems in Technologies, Storage Facilities
- In-Situ Resources Represent a Possible Source of H₂O, O₂, Carbon for Use by Life Support Systems
- Possible Use of Mars or Lunar Soil in Life Support Systems Filtration/Adsorption

System Integration and Analysis Working Group

LABORATORY SYSTEMS

- Waste Handling
 - ▶ Similar Organic Wastes, but Likely to be Segregated from Human Wastes
 - ▶ Need for Odor Control - Toxic Contamination Control
- Water Supply, Clean-Up Issues
 - ▶ Relation to Life Support Systems
 - Lab Systems will be Isolated from Life Support Systems to Minimize Contamination, Hence Minimal Interaction
 - Possibility for Use of Common Technologies

System Integration and Analysis Working Group

USE OF LIFE SUPPORT SYSTEMS WASTES

- Reuse of Life Support Systems Wastes
 - ▶ Ash
 - Shielding
 - ▶ Waste Plastics
 - Remanufacture into New Packaging, etc.
 - Decompose into C, H for Use in Life Support Systems and Elsewhere
 - Use as Radiation Shielding
 - ▶ Waste Metals
 - Remanufacture into Foils, Structural Materials, etc.
 - ▶ Spent Tanks, Resupply Units Used in Life Support Systems Resupply
 - Cut Down into Structural Materials
 - ▶ Excess Water From Life Support Systems
 - Use as Radiation Shielding

- Low Tech or Uses (Mostly) Well-Developed Technologies that may need some Re-Engineering to Minimize Generation of Toxics

System Integration and Analysis Working Group

EXTRAVEHICULAR ACTIVITY (EVA)

- Environmental Control Life Support System (Suit and Vehicle) Recharge Issues
 - ▶ Life Support System Will Need to Resupply EVA, and to Process Wastes from EVA
- Suit Cleaning
 - ▶ Common Fluids?? Water
- Other
 - ▶ EVA is a Source of Possible Contaminants (e.g., Dust) Harmful to the Life Support Systems

System Integration and Analysis Working Group

EXISTING SOFTWARE FOR MODELING INTEGRATED SYSTEMS

- Integrated System Performance Model (ISPM)
 - ▶ Electrical, Thermal, Guidance, Life Support, Solar/External
 - ▶ Developed for Space Station Freedom

Contact: John Tandler, Grumman (703) 438-5786

- Integrated Systems Analysis Tool for Space Exploration Initiative

Contact: Henry Woo, David Haines, Rockwell-Downey, CA

- System Design Trade-Off Model (SDTM)
 - ▶ Developed for Space Station Freedom

Contact: Jeff Smith, JPL

System Integration and Analysis Working Group

RECOMMENDATIONS

- NASA HQ Sponsor a Meeting of Key Technical Staff Involved in Power, Propulsion, Life Support, etc. Arrange Overview Briefings
 - ▶ Currently, Individuals Do Not Understand Other Systems as well as is Needed
- Screen List of Possible Interactions using Analysis of Risk and Reliability Dependencies and Other System Engineering Techniques
- Investigate Possibilities for Common Materials, Components among systems

THIS PAGE INTENTIONALLY LEFT BLANK

REPORT DOCUMENTATION PAGE

Form Approved
OMB No. 0704-0188

Public reporting burden for this collection of information is estimated to average 1 hour per response, including the time for reviewing instructions, searching existing data sources, gathering and maintaining the data needed, and completing and reviewing the collection of information. Send comments regarding this burden estimate or any other aspect of this collection of information, including suggestions for reducing this burden, to Washington Headquarters Services, Directorate for Information Operations and Reports, 1215 Jefferson Davis Highway, Suite 1204, Arlington, VA 22202-4302, and to the Office of Management and Budget, Paperwork Reduction Project (0704-0188), Washington, DC 20503.

1. AGENCY USE ONLY (Leave blank)	2. REPORT DATE 1 March 1992	3. REPORT TYPE AND DATES COVERED Final - 1991 Report	
4. TITLE AND SUBTITLE 1991 Life Support Systems Analysis Workshop Workshop Report			5. FUNDING NUMBERS Contract #NASW-4470
6. AUTHOR(S) Evanich, Peggy L.; NASA Headquarters Crabb, Thomas M.; Orbital Technologies Corporation Gartrell, Charles; General Research Corporation			
7. PERFORMING ORGANIZATION NAME(S) AND ADDRESS(ES) Orbital Technologies Corporation 402 Gammon Place, Suite 10 Madison, Wisconsin 53719			8. PERFORMING ORGANIZATION REPORT NUMBER N/A
9. SPONSORING/MONITORING AGENCY NAMES(S) AND ADDRESS(ES) Office of Aeronautics and Space Technology National Aeronautics and Space Administration Washington, DC 20546			10. SPONSORING/MONITORING AGENCY REPORT NUMBER NASA CR 4466
11. SUPPLEMENTARY NOTES			
12a. DISTRIBUTION/AVAILABILITY STATEMENT Unclassified - Unlimited Subject Category 54			12b. DISTRIBUTION CODE
13. ABSTRACT (Maximum 200 words) The 1991 Life Support Systems Analysis Workshop was sponsored by NASA Headquarters' Office of Aeronautics and Space Technology (OAST) to foster communication among NASA, industrial, and academic specialists, and to integrate their inputs and disseminate information to them. The overall objective of systems analysis within the Life Support Technology Program of OAST is to identify, guide the development of, and verify designs which will increase the performance of the life support systems on component, subsystem, and system levels for future human space missions. The specific goals of this workshop were to report on the status of systems analysis capabilities, to integrate the chemical processing industry technologies, and to integrate recommendations for future technology developments related to systems analysis for life support systems. The workshop included technical presentations, discussions, and interactive planning, with time allocated for discussion of both technology status and time-phased technology development recommendations. Key personnel from NASA, industry, and academia delivered inputs and presentations on the status and priorities of current and future systems analysis methods and requirements.			
14. SUBJECT TERMS space modeling simulation life support systems analysis analysis			15. NUMBER OF PAGES 118 16. PRICE CODE AO9
17. SECURITY CLASSIFICATION OF REPORT Unclassified	18. SECURITY CLASSIFICATION OF THIS PAGE Unclassified	19. SECURITY CLASSIFICATION OF ABSTRACT Unclassified	20. LIMITATION OF ABSTRACT Unlimited





