

SUPERCONDUCTING LINEAR ACTUATOR

by

Bruce Johnson and Richard Hockney
SatCon Technology Corporation
Cambridge, MA

N 93-27577
5-3-187
163503
p. 12

ABSTRACT

Special actuators are needed to control the orientation of large structures in space-based precision pointing systems. Electromagnetic actuators that presently exist are too large in size and their bandwidth is too low. Hydraulic fluid actuation also presents problems for many space-based applications. Hydraulic oil can escape in space and contaminate the environment around the spacecraft. A research study was performed that selected an electrically-powered linear actuator that can be used to control the orientation of a large pointed structure. This research surveyed available products, analyzed the capabilities of conventional linear actuators, and designed a first-cut candidate superconducting linear actuator.

The study first examined theoretical capabilities of electrical actuators and determined their problems with respect to the application and then determined if any presently available actuators or any modifications to available actuator designs would meet the required performance. The best actuator was then selected based on available design, modified design, or new design for this application. The last task was to proceed with a conceptual design.

During this study, no commercially-available linear actuator or modification capable of meeting the specifications was found. A conventional moving-coil dc linear actuator would meet the specification, but the back-iron for this actuator would weigh approximately 12,000 lbs. A superconducting field coil, however, eliminates the need for back iron, resulting in an actuator weight of approximately 1000 lbs.

INTRODUCTION

SatCon Technology Corporation has performed a study directed toward selecting an electrically-powered linear actuator which could be used to control the orientation of a large, space-based precision pointed structure. This paper reports the findings of that research including the baseline design, a superconducting dc linear actuator. This introductory section provides background, specifications, and selection criteria.

In this application, linear actuators are used to rapidly orient (slew) a large (25kg) space structure. Reaction masses (counterweights) are driven in the opposite direction to conserve momentum. Figure 1 shows two possible laboratory tests for one of the linear actuators (with and without a reaction mass). The laboratory test is sized to simulate the load on the actuator in actual orbital operation. The actuator must step the position (x) of the mass at constant step period (T) and varying amplitude (x_s). The desired acceleration profile for the load mass is defined by the cube of a

sine-wave. The desired position, velocity (v), and acceleration (a) trajectories as a function of time (t) are defined by the following equations.

$$\begin{aligned}
 a(t) &= (3 x_s/T^2)\sin^3[2 (t/T)] \\
 v(t) &= [x_s/(2T)]\{2 - 3\cos[2 (t/T)] + \cos^3[2 (t/T)]\} \\
 x(t) &= x_s\{(t/T) - (1/2) \sin[2 (t/T)] - (1/12) \sin^3[2 (t/T)]\}
 \end{aligned}
 \tag{1.1}$$

Table 1 presents the kinematic parameters (length and time for the step) which define the time profiles. The maximum step length is used to size the capacity for the actuator while the rms value determines the steady-state requirements.

Table 1. Kinematic Parameters

Step Period	0.016 sec.	
Step Length (max.)	5.0 cm	(2 in.)
	(rms)	2.5 cm (1 in.)

As shown in figure 2, the net load (f) acting on the actuator is the sum of the inertial (D'Alembert), viscous friction, and coulomb friction forces. Table 2 presents the parameters which determine the load on the actuator.

Table 2. Load Parameters

Load Mass (m_L)	25 kg	(54 lb _m)
Viscous Friction Coefficient (b)	73 N/m/s	
Coulomb Friction (f_C)	454 N	(100 lb _f)

The following equation defines the load profile.

$$f(t) = m_L \cdot a(t) + b \cdot v(t) + f_C \cdot \text{sgn}[v(t)] \tag{1.2}$$

Figure 3 shows the load profile that the actuator must produce during the maximum length step. The final specifications for the actuator are derived from this analysis and are presented in Table 3.

Table 3. Actuator Specifications

Maximum Total Travel	25 cm	(10 in.)
Maximum Velocity	6.3 m/s	(20 ft/sec)
Maximum Acceleration	1830 m/s ²	(6,000 ft/sec ²)
Maximum Force	45,000 N	(10,000 lb _f)
First Mode Structural Frequency	500-1000 hz	

The acceptability of each electrically-driven linear actuator was determined by its performance relative to that of an alternative hydraulic actuator. The performance parameters which were used to determine acceptability are listed below.

- 1) Energy Efficiency
- 2) Volume and Weight
- 3) Interface Requirements (Electrical and Cooling)
- 4) Environmental Compatibility

The final criterion implies that the actuator must be compatible with both laboratory and exo-atmospheric environments unless a design which is intended for Earth-based applications can be readily modified for space.

CONVENTIONAL LINEAR ACTUATORS

The first phase of the research examined conventional linear actuators, both commercially available and custom designs. The survey of over fifty manufacturers, including telecons with leading linear actuator manufacturers, indicated that the only commercially available technology that could come close to meeting the specifications was a motor/lead screw combination. The state-of-the-art in lead-screw technology for these loads is a few inches a second, however, compared to the 20 feet per second required. The conclusion of the product survey was that neither an existing design nor a modification of an available actuator design would meet the performance requirements for this application. The study next proceeded to the analysis of the theoretical capability of known types of linear actuators.

The various conventional linear actuators that were examined can be divided into three categories.

- 1) Rotary motors with transmissions
- 2) Linear motors
- 3) Linear actuators

The distinction between the second and third categories is that a linear motor requires commutation and its stroke is limited only by the length of its stationary component. The stroke of a linear actuator is limited by some combination of the length of the stationary and moving components, and no commutation is required.

For each type of actuator, first order models that predicted the geometry, moving mass, and stationary mass were developed. These models all had common assumptions with regard to magnetic materials, conductive materials, and mechanical impedance. A summary of the results of this study are listed below. A more detailed description of the results and development of the models is found in [Hockney 1986].

Rotary Motors Both axial and radial air-gap motors were examined. The axial air-gap motor could produce sufficient torque and an adequate torque/inertia ratio only at high (18,000 rpm) speeds. As mentioned earlier, the problem with rotary motors is that no mechanical method of transmission to linear motion exists that can meet the specifications, especially the 20 ft/sec speed.

Linear Synchronous Motor This is a linear analog of a brushless dc motor. It was found to be impractical because of the large gap required (11 cm).

Linear Induction Motor This linear analog of a common induction motor would require an armature of 3.8m length and 1.6 cm radius. This long, thin rod is impractical for this application.

Reluctance Linear Actuator As for the linear synchronous motor,

this approach is impractical because of the large air gap required.

Solenoid This approach requires too much moving mass to produce the required force and cannot, therefore, meet the acceleration requirement.

DC Linear Actuator DC linear actuators (voice coils) are typically used in fixed-based applications such as shaker tables where large forces and relatively long strokes are required. Of all the conventional options examined, this device was the only one that could meet the specifications. It would require nearly six metric tons of soft iron, however, to shape the magnetic field, which is grossly excessive for any space-based application.

SUPERCONDUCTING ACTUATOR

Based on the results of the above analysis, a linear actuator utilizing conventional technology would weigh approximately two orders of magnitude more than its hydraulic counterpart. Thus, the investigation toward an actuator was based upon superconducting technology. This decision was motivated by two factors. First, a superconducting actuator could be built using the same principle as the conventional dc linear actuator which, except for the weight of its back-iron, was shown to be the "best" electrical linear actuator for this application. Second, the application of superconducting technology to this actuator type held the promise of significantly reducing its weight. This is true for the following reasons:

- 1) The current density in the field coil can be extremely high (roughly 10^8 A/m²);
- 2) This level of current density allows the system to be constructed without the use of back-iron;
- 3) The lack of back-iron allows higher operating flux density in the area of the moving coil armature by about a factor of two.

As stated above, the superconducting actuator concept is based upon the same principle as the dc linear actuator. The concept drawing is shown in Figure 3. In this cross-sectional drawing, the cross-hatched area represents the superconductor volume. There are a pair of oppositely excited, mechanically attached armature coils shown operated at current density J. The vectors B and f represent the field flux density and the Lorentz force, respectively. Thus there is a large net force acting to the right on the armature as well as two smaller forces tending to compress one coil and expand the other. Obviously the direction of the forces may be reversed by changing the direction of the current density in both coils.

As shown in Figure 4, the two armature (moving) coils are attached by a shaft that runs through the center of the superconductor dewar. The load mass is attached to the end of this shaft. For baseline system sizing, simple models were developed that relate the geometry and placement of the armature (moving) coils and superconductor to system performance. A minimization procedure was then used to arrive at the minimum mass design. An example of the results of this

analysis are shown in Figure 5. Shown is a plot of subcomponent (structure (st), armature coil (c), superconductor (s)) and total (t) system mass versus radial magnetic flux density at the armature. For small fields, the mass of armature coil needed increases dramatically. At larger fields, the armature coil mass decreases but at the cost of more superconductor (field coil) mass. As shown, these two effects result in a minimum mass design of approximately 300 kg.

After the preliminary design was developed using simple subcomponent models, a more detailed design was begun. The major areas of design effort are briefly presented below. A more detail discussion can be found in Hockney [1987].

Structural design The moving structure must transmit a peak force of 15,900 lb_f with a first mode frequency greater than 500 hz. The moving structure must be as light as possible. Because of the 200 g acceleration of the moving mass, each additional lb_m of moving structure increases the peak actuator force requirement by 200 lb_f . After extensive design and modelling, a beryllium moving structure was chosen. Sectional views of half of the structure are shown in Figure 6. The moving structure consists of shaft sections attached to the armature assembly. The armature assembly contains the wound aluminum tape armature coil connected to the shaft by a conical shaped web.

Superconductor design The superconductor design, of course, is central to this actuator. A variety of superconducting design issues arose, some common to any superconducting coil and some unique to this application.

Any low-temperature (conventional) superconductor requires a cryostat to maintain the superconducting temperature with a minimum of power consumption. This cryostat design is made more difficult when it must also support the large loads (10000 lb_f) required for dc force testing of this actuator. The resulting design has the superconducting solenoid contained in a stainless-steel coil housing which holds liquid helium. Several inches of aluminized mylar insulation (also called "super-insulation") surrounds the inner dewar in an evacuated space. An aluminum or stainless-steel vacuum jacket surrounds the insulating layer. The coil housing is supported with respect to the vacuum jacket by a series of stainless-steel spokes. For this superconductor run in the laboratory, the expected heat loss is about 3 watts of power at 4.2 degrees Kelvin. This would require a liquid helium refrigeration system that consumes less than 10 kW.

Another, more unique design issue is posed by the high frequency magnetic fields produced by the armature coils. The superconductor must be shielded from these fields or else large circulating currents in the superconductor would be generated, causing the superconductor to go normal. This shielding requires the placement of a conductive, eddy current shield around the ends of the superconductor. The eddy currents generated in this shield will partially attenuate the forces and fields which are experienced by the superconducting solenoid.

The superconducting solenoid required for this application is relatively large compared to the usual, commercially available solenoids. Because of its size, both the self-induced stresses in the solenoid and the large stored energy require special design considerations. The size and field requirements also drive the design to high-performance niobium-tin (NbSn) superconductor versus the more conventional niobium-titanium (NbTi) superconductor.

Interaction with Earth's Magnetic Field The large dipole moment of the superconductor, approximately 500 kAm^2 , will produce relatively large torques, on the order of 10 Nm, due to interaction with the Earth's magnetic field. Three approaches were investigated to ameliorate this problem.

- 1) The use of a control moment gyro
- 2) The use of an equal and opposite dipole
- 3) The use of magnetic shielding

The first two approaches are possible, with the magnetic shielding requiring too much mass. Control moment gyros are available in this size range, however, the approach of using an equal and opposite dipole appears the best. This is a natural approach for this application since dummy actuators moving reaction loads will be required to counterbalance the moving load.

Electrical Power The armature requires a peak current of over 1000 Amps, as shown in Figure 7. The corresponding armature voltage waveform is shown in Figure 8. The armature voltage consists primarily of inductive and back-emf voltage. The volt-amp waveform, which sizes the power electronics, is shown in Figure 9. The peak volt-ampereage required is approximately 2 MVA. About 600 kW of peak power is mechanically delivered to the load. These requirements can be met with commercially available components. The electrical connection to the armature must be extremely flexible to accommodate the 10" total stroke and must be very strong to withstand the 200 g acceleration with a large cycle-life. The solution was to use a commercially available high-current, flexible strap.

SUMMARY

SatCon Technology Corporation has performed a study directed toward selecting an electrically-powered linear actuator which could be used to control the orientation of a space-based, precision pointed structure. After an extensive review of existing and conventional electromagnetic actuators, none of which could meet the specifications, a superconducting design was developed that could. The candidate linear actuator has a total mass of 447 kg, a rms power requirement of 174 kVA, and an occupied volume of 0.6 m diameter by 0.82 m long.

REFERENCES

[Hockney 1986] James Downer and Richard Hockney Linear Actuator Engineering Study. SatCon Technology Report R01-86, Cambridge, MA: August 1986.

[Hockney 1987] Richard Hockney, et al. Design Definition for a Superconducting Actuator. SatCon Technology Report R10-87, Cambridge, MA: November 1987.

DUAL-ACTUATOR TESTS

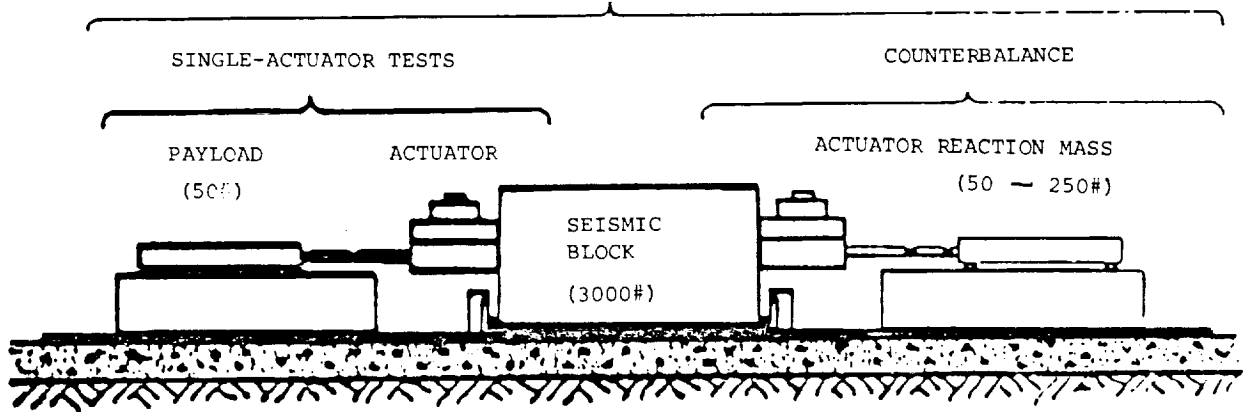

Figure 1. Actuator Test Bed.

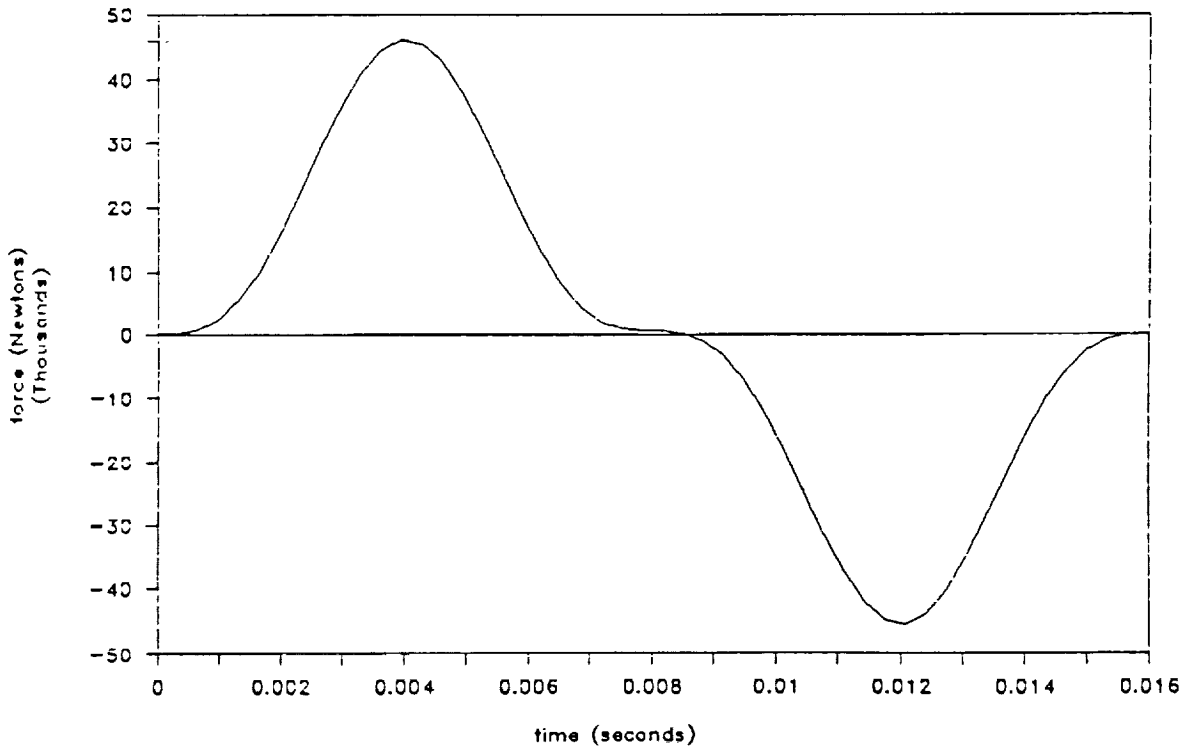

Figure 2. Required Force Profile.

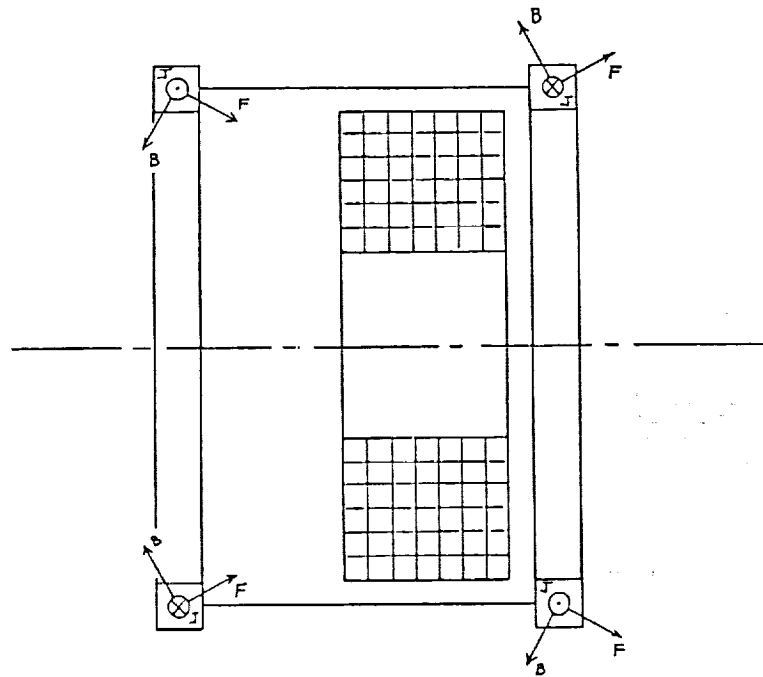

Figure 3. Superconducting Linear Actuator Concept.

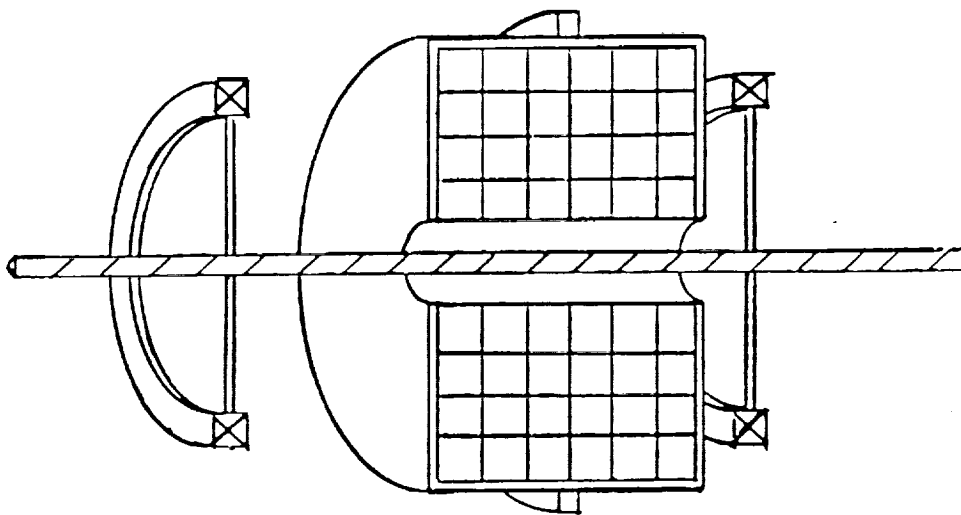

Figure 4. Baseline Configuration.

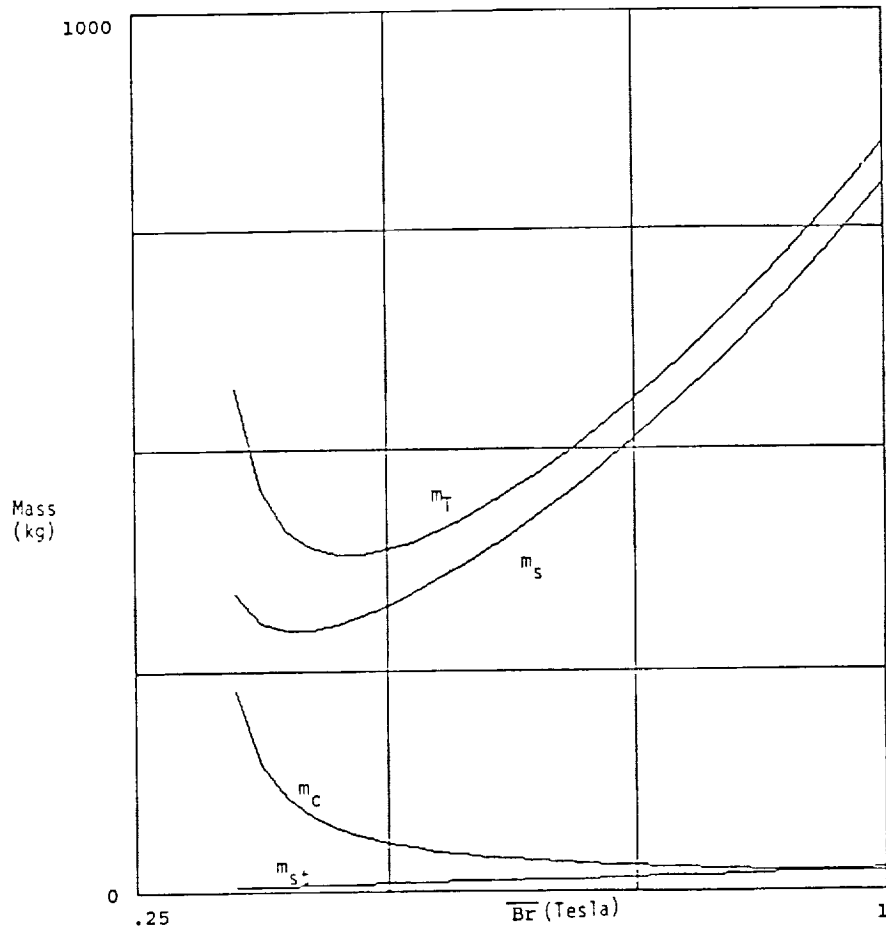
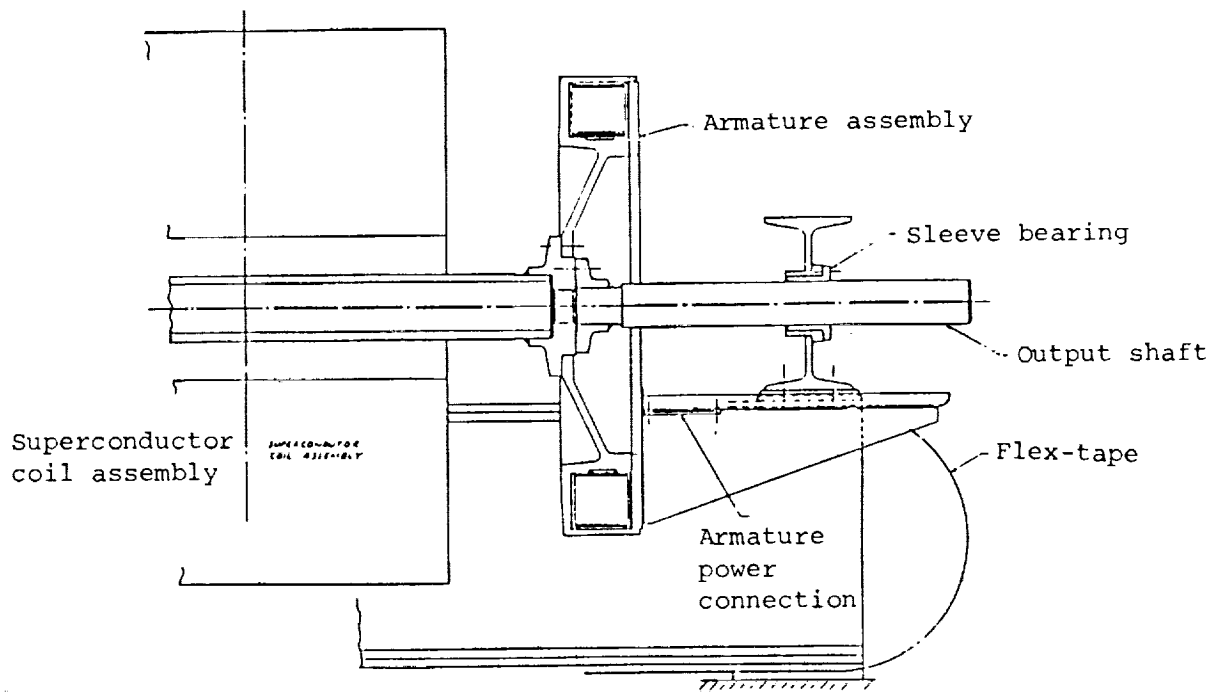
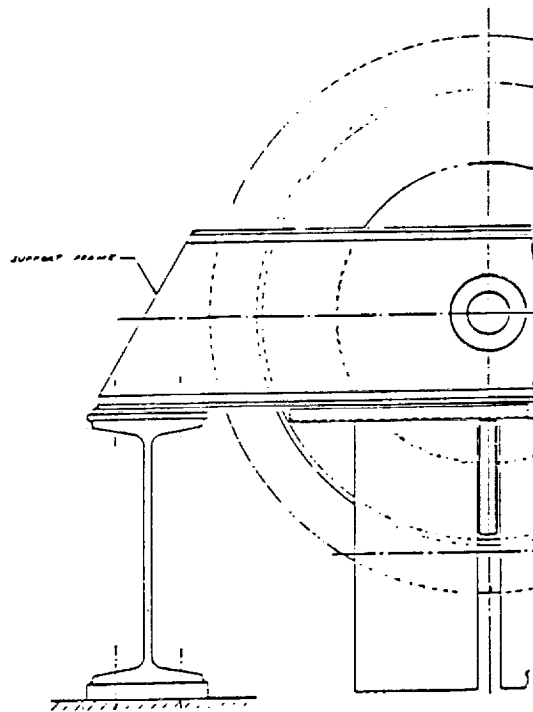

Figure 5. Mass vs Radial Flux Density at the Armature.



(a) Section View



(b) View Along Output Shaft

Figure 6. Overall Linear Actuator Design.

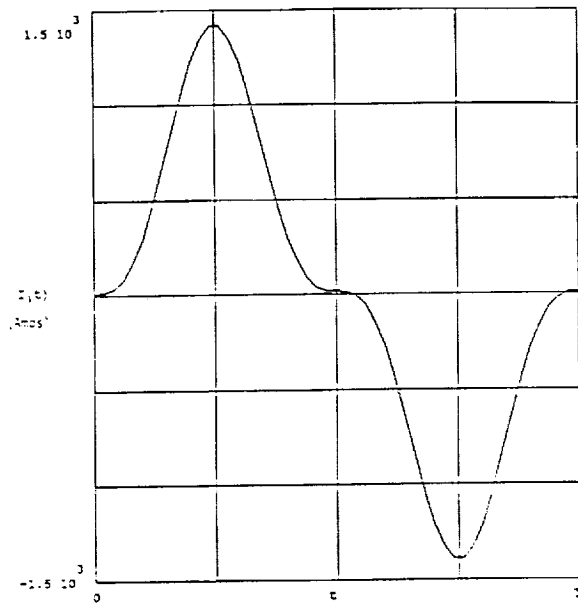

Figure 7. Armature Current Waveform.

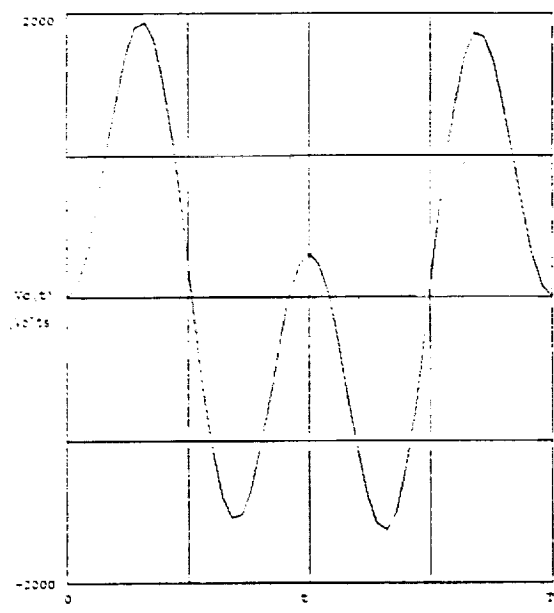

Figure 8. Armature Voltage Waveform.

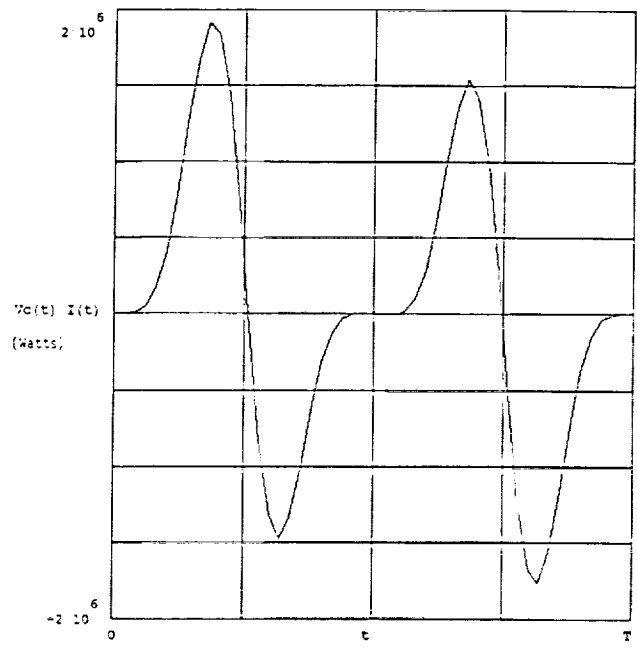

Figure 9. Armature Volt-ampere Waveform.