

11365
1-50
93-27836

NASA/JSC
DR. KORNEL NAGY
713-483-8830

STRUCTURES FOR SPACE STATION FREEDOM

OVERVIEW OF CURRENT CONCEPT

4
INTENTIONALLY BLANK

AGENDA

INTRODUCTION

STRUCTURES SUBSYSTEM

MECHANICAL SUBSYSTEM

EVOLUTION ISSUES

INTRODUCTION

- **SSF IS FIRST SPACECRAFT ASSEMBLED ON-ORBIT**
- **STRUCTURAL CONCEPT DEVELOPED TO ACCOMMODATE PHASED ASSEMBLY**
 - CONCEPT ORIGINATED AT LARC**
 - FINAL DESIGN UNDERWAY**
- **STRUCTURES DEVELOPMENT TO ENABLE POSSIBLE STATION GROWTH OPTIONS**
 - POWER SYSTEM GROWTH**
 - CONSTRUCTION ACTIVITIES**
 - LUNAR/MARS INITIATIVE**

4
ALMA L. THOMPSON

STRUCTURES SUBSYSTEM

The WP-02 Assembly Truss and Structures subsystem includes the Assembly Truss, Mobile Transporter, Airlock, and Resource Node structure. The Station Assembly Truss includes all truss structures pallets, component supports, and module to truss interface structure. The turntable, hinge, and track assemblies, and the upper and lower base are WP-02 structural components of the Mobile Transporter. Within the Airlock, WP-02 structural responsibility includes structure, secondary structures, micro-meteoroid and debris shields, NRS attachment equipment, and grapple fixtures. The Resource Node structural subsystem contains the primary and secondary structures, micro-meteoroid/debris shields, NRS grapple and attachment fixtures, and the cupola (MSFC supplied).

STRUCTURES / MATERIALS

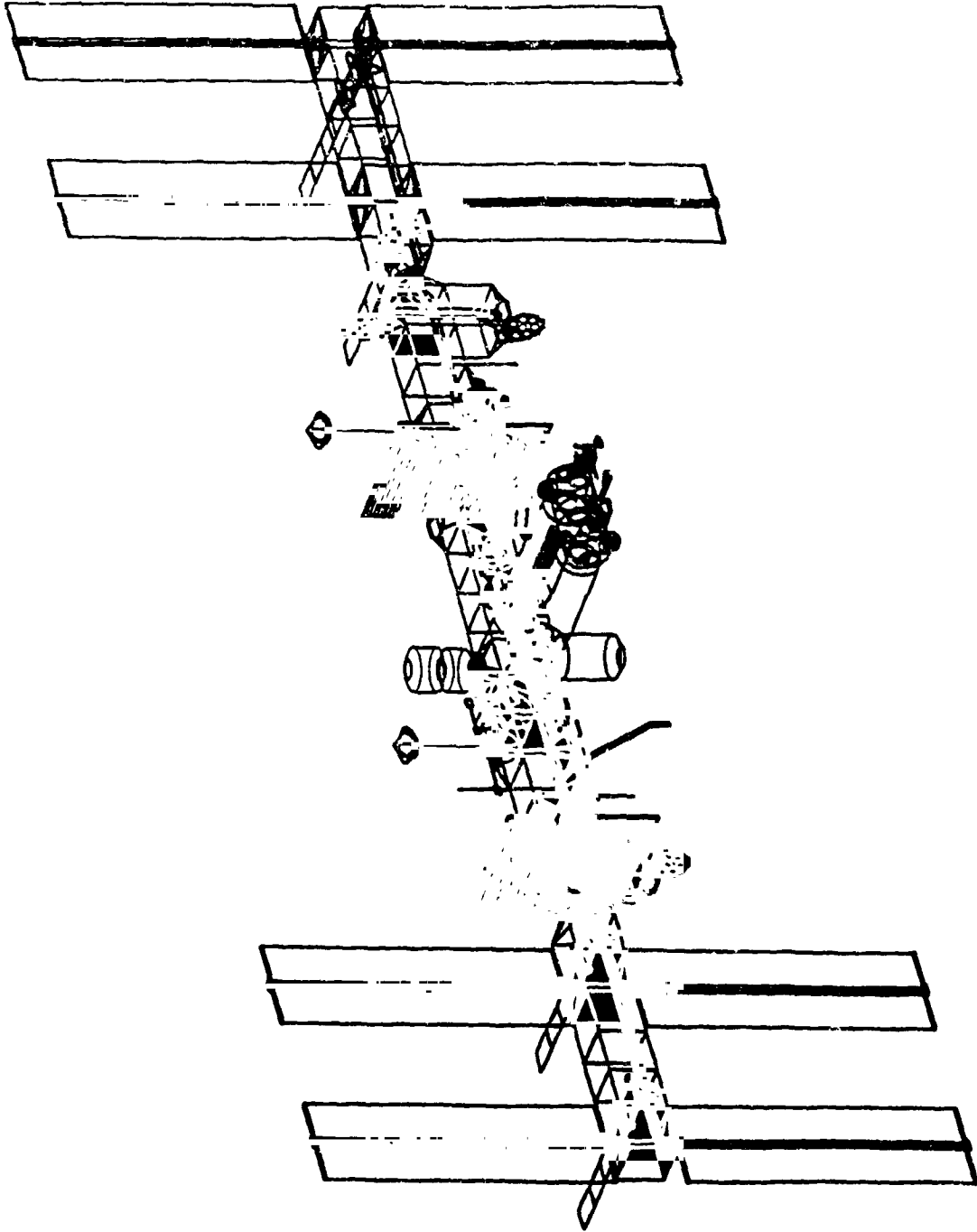

ASSEMBLY TRUSS/STRUCTURES

- **ASSEMBLY TRUSS STRUCTURES -- TRUSS STRUCTURES, COMPONENT SUPPORT/ADAPTORS
RESOURCE PALLETS, MODULE TO TRUSS INTERFACE STRUCTURE, UTILITY TRAYS**
- **MOBILE TRANSPORTER STRUCTURE-- UPPER BASE, TURNABLE ASSEMBLY, TRACK
ASSEMBLY, HINGE ASSEMBLY, LOWER BASE**
- **AIRLOCK STRUCTURE-- PRIMARY STRUCTURE, SECONDARY STRUCTURE,
METEROID DEBRIS SHIELD, NSTS ATTACHMENT FIXTURES AND GRAPPLE FIXTURES**
- **RESOURCE NODE STRUCTURE-- PRIMARY AND SECONDARY STRUCTURE,
METEROID/DEBRIS SHIELD, NSTS ATTACHMENT AND GRAPPLE, CUPOLA**
- **HAB AND LAB MODULE STRUCTURE-- PRIMARY AND SECONDARY STRUCTURE
METEROID/DEBRIS SHIELD, NSTS ATTACHMENT AND GRAPPLE**

Requirements for the Station structure are meant to insure the integrity of the configuration, the accomplishment of mission goals, and the safety of the crew. To this end, the structure must be able to provide support for all equipment attached to the Space Station, both payloads and other Station subsystems. The primary truss structure must provide adequate stiffness such that Station maneuvering (i.e. docking, reboost, attitude control, etc.) can be accomplished with adequate control system stability margins. The overall stiffness and thermal stability of the structure must also contribute to achieving the pointing requirements for the antennas and payloads. The Space Station Freedom is designed for a 30 year on-orbit life. The structural subsystem must meet the structural requirements for the entire design life of the Station. Therefore, structural components must be resistant to the degrading effects of the space environment (i.e. radiation) and tolerant to damage inflicted by space borne particles (i.e. micro-meteoroid and debris).

FUNCTIONAL AND PERFORMANCE REQUIREMENTS

- **STRUCTURAL SUPPORT FOR ALL SUBSYSTEMS (MODULES, POWER, THERMAL, FLUIDS...)**
- **ACCOMMODATE PAYLOADS, PROPULSION MODULES, UNIVERSAL PALLETS...**
- **ADEQUATE STIFFNESS FOR STATION MANEUVERING (DOCKING, REBOOST, ATTITUDE CONTROL)**
- **SUPPORT PAYLOAD AND ANTENNA POINTING REQUIREMENTS**
- **30 YEAR LIFE**
- **DAMAGE TOLERANCE**
- **MINIMUM WEIGHT**

Space Station Freedom is designed to be assembled in Earth orbit from resources delivered by the NSTS. Structural designs must account for the assembly process that includes the NSTS payload bay for manifesting, the Remote Manipulator System (RMS) for grappling, holding, and positioning, and special considerations for the EVA crewman.

In addition to the above requirements, special consideration is given to pressurized vessels on the Space Station. The stored energy in these vessels presents a potential hazard to the Station and crew (particularly EVA crew). These systems are designed to "leak before rupture" requirements. Further, other Station structure (and systems) must consider the effects of pressurized vessel explosive failure in their design.

FUNCTIONAL AND PERFORMANCE REQUIREMENTS

- **ON-ORBIT ASSEMBLY OF STRUCTURE**
 - LAUNCH COMPONENTS STOWED IN CARGO BAY**
 - SEQUENCED ASSEMBLY OF STRUCTURE AND SUBSYSTEMS**
 - LIMITED AVAILABILITY OF EVA**

STRUCTURES / MATERIALS

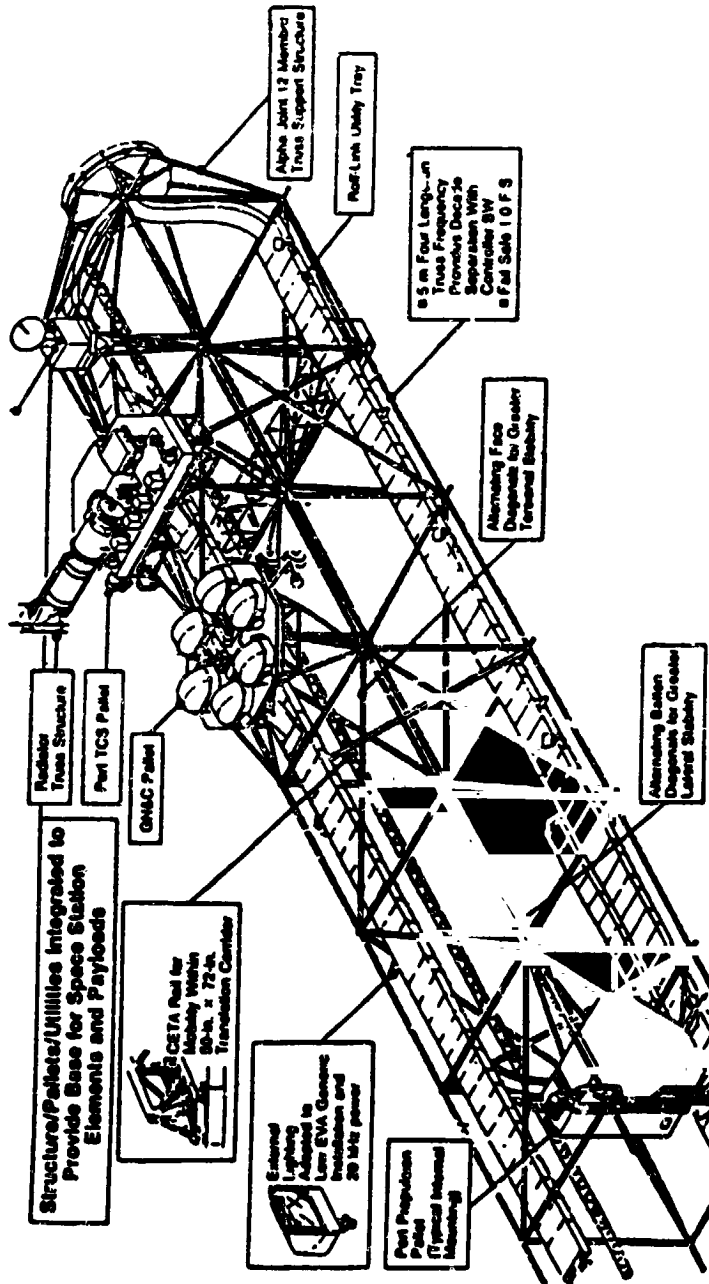

PORION OF TRUSS WITH SUBSYSTEMS

20

The primary truss structure consists of a 5 meter cubical cell composed of graphite/epoxy struts. The strut outside diameter has been sized to 2 inches to accommodate the grip of the EVA crewman. The truss struts have specially designed end fittings that enable complete truss construction by EVA. The truss was sized at 5 meters to provide stiffness margin for the control system. Also, the 5 meter truss provides an internal cross-section equivalent to the Orbiter payload bay.

DESIGN IMPLEMENTATION

- **PRIMARY TRUSS**
 - 5.METER CUBICAL CELL SIZE**
 - EVA ERECTABLE**
 - GRAPHITE /EPOXY TRUSS TUBES**
- **MODULE TO TRUSS INTERFACE STRUCTURE**
 - DEPLOYABLE TRUSS**
- **UNIVERSAL PALLETS**
 - LIGHTWEIGHT PALLET DESIGN**
 - FOLD-OUT STRUTS FOR STATION ATTACH OF PALLETS**
 - DUAL USE PALLETS, STATION AND ORBITER PAYLOAD BAY**

STRUCTURES / MATERIALS

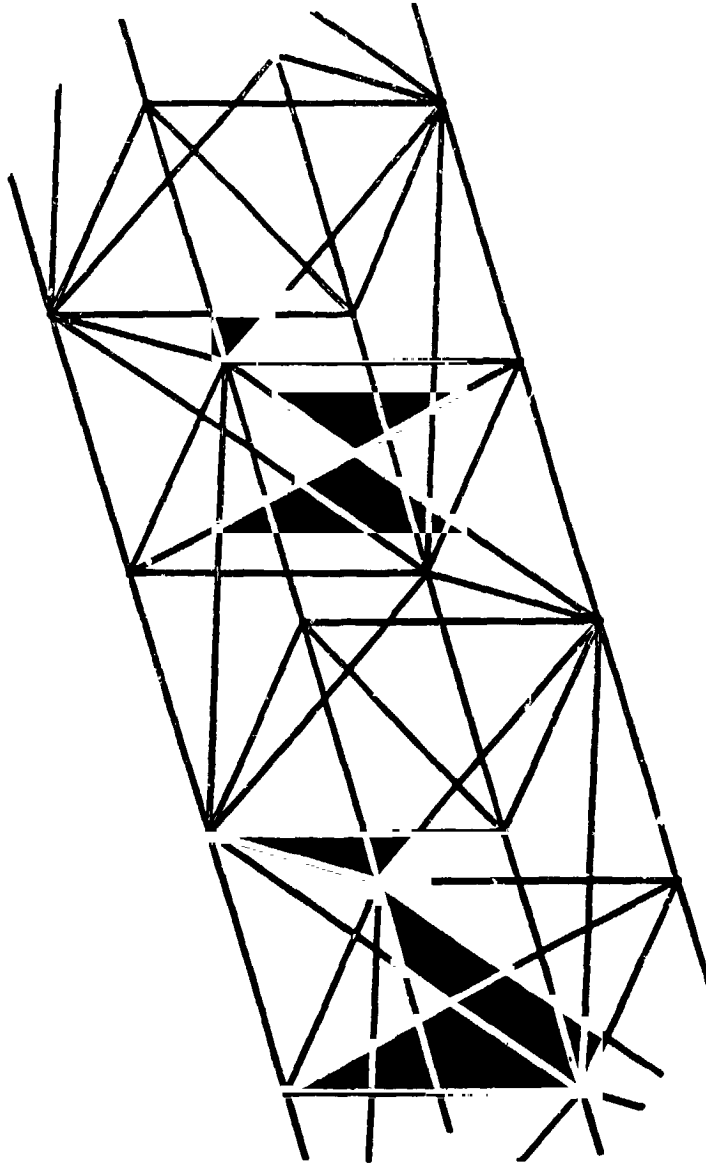

5 METER PRIMARY TRUSS

STRUCTURES / MATERIALS

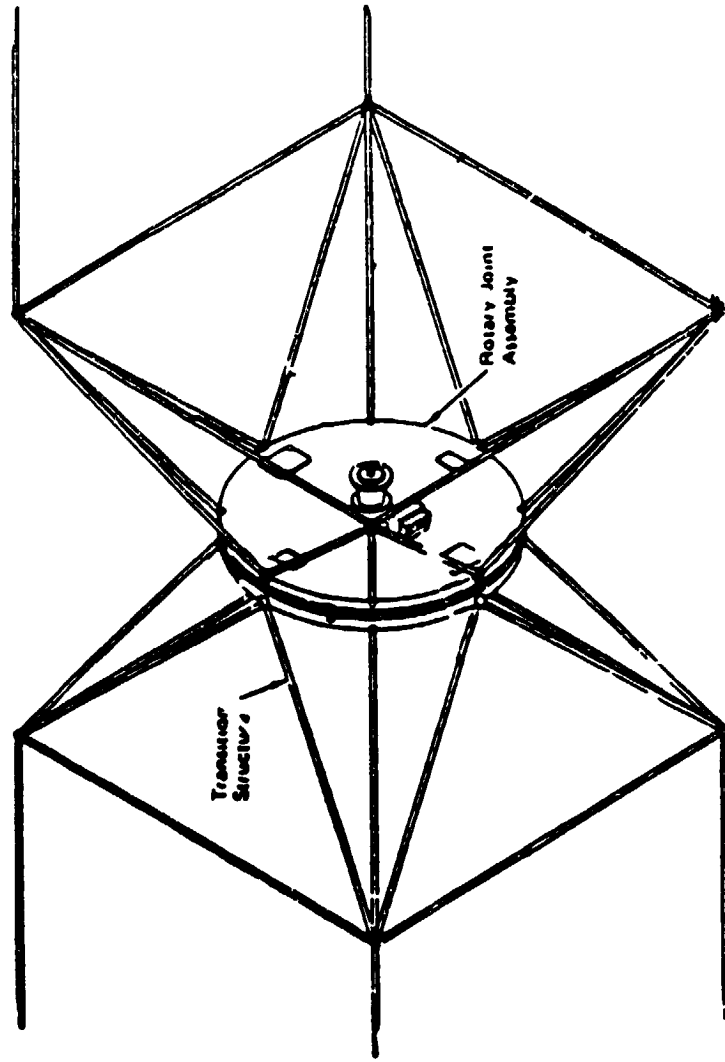

ALP.1A JOINT WITH TRANSITION STRUCTURE

The resource pallets are a light weight aluminum design that supports subsystem components during launch. When connected to the Space Station, these pallets become the hardware platform that structurally integrates the subsystems into the Space Station. The resource pallet design allows for truss and utility connections to be common for all subsystems supported by a pallet.

STRUCTURES / MATERIALS

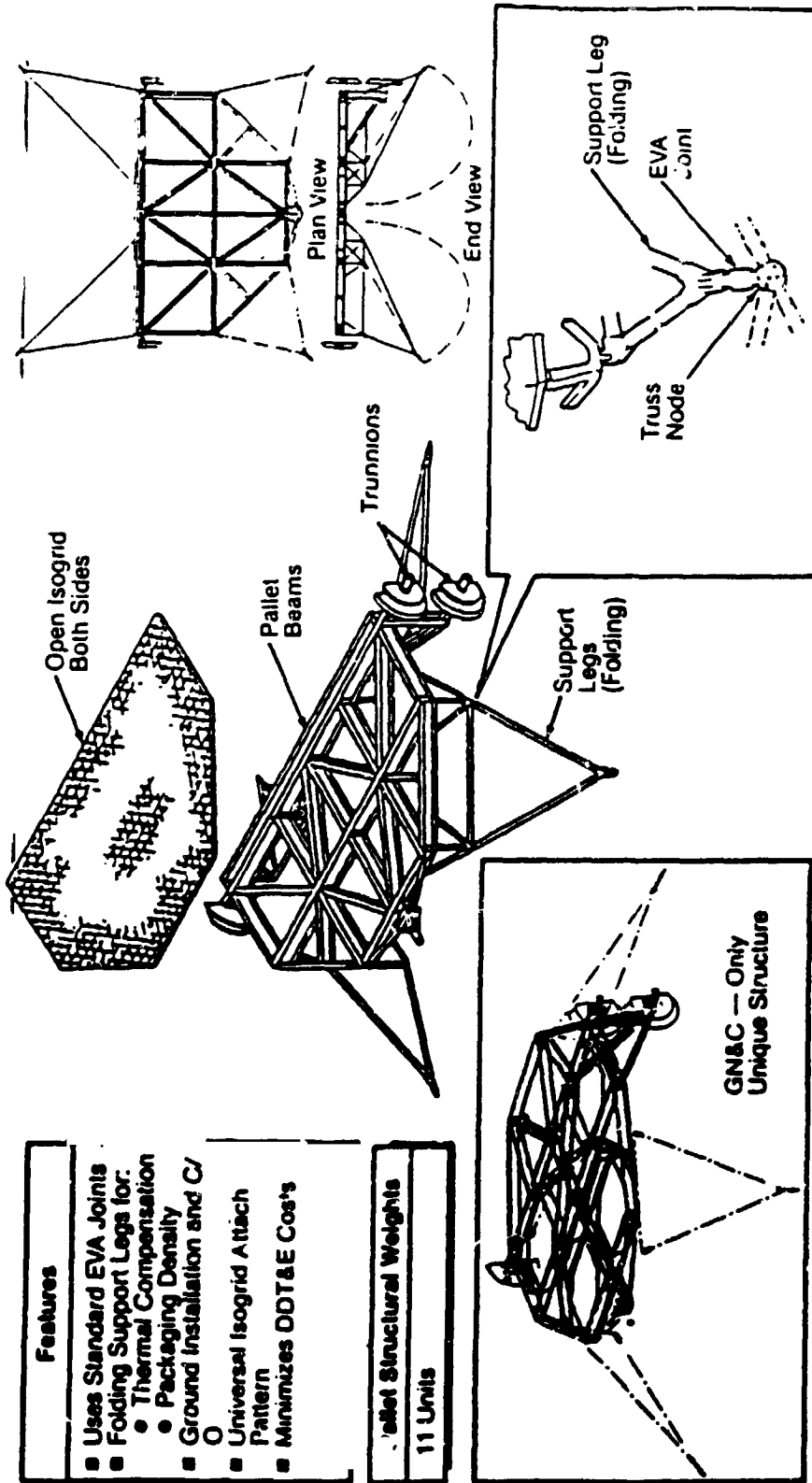

UNIVERSAL PALLET

STRUCTURES / MATERIALS

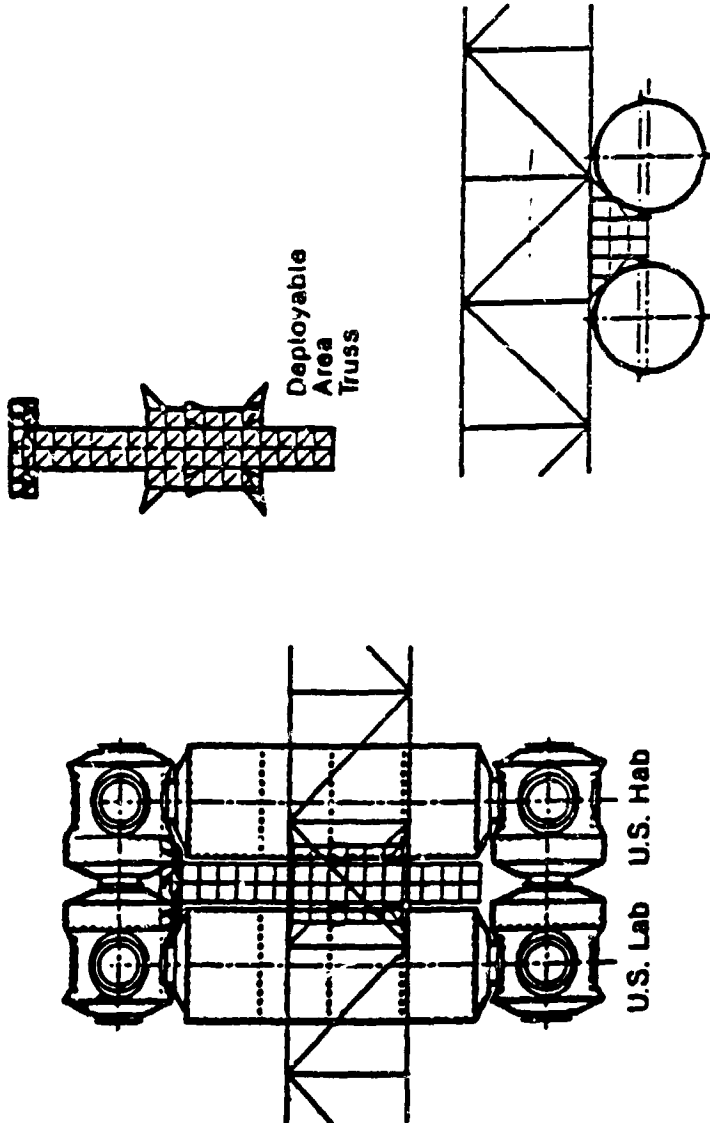

MODULE TO TRUSS INTERFACE STRUCTURE

The mobile transporter base assembly consists of an upper and lower layer that can slide relative to each other. Sliding one layer forward (or backward) to pick up the nodes of the next bay of truss is the method by which the transporter move along the truss. A additional degree of freedom is achieved by a central rotatable system that allows the transporter to rotate, while still attached to the truss, about an axis perpendicular to the truss face attached to the base.

STRUCTURES / MATERIALS

MOBILE TRANSPORTER

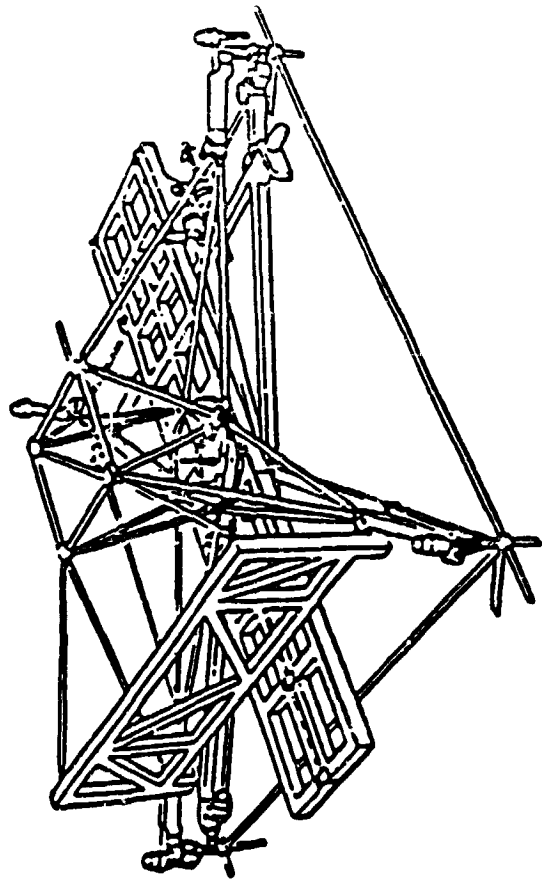
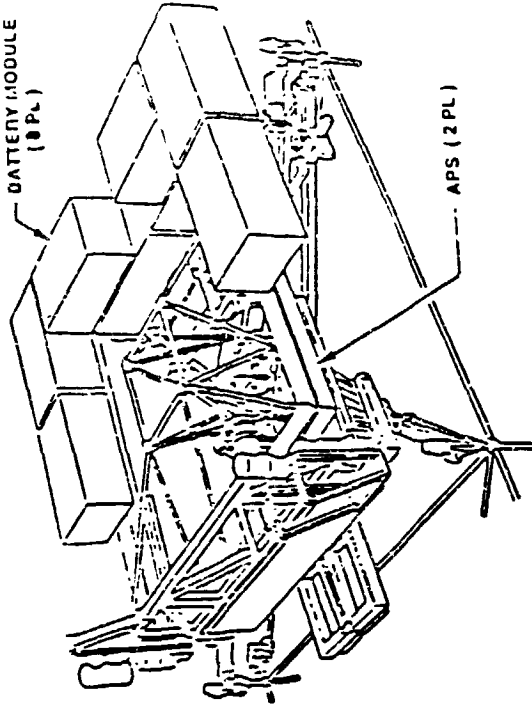

STRUCTURES / MATERIALS

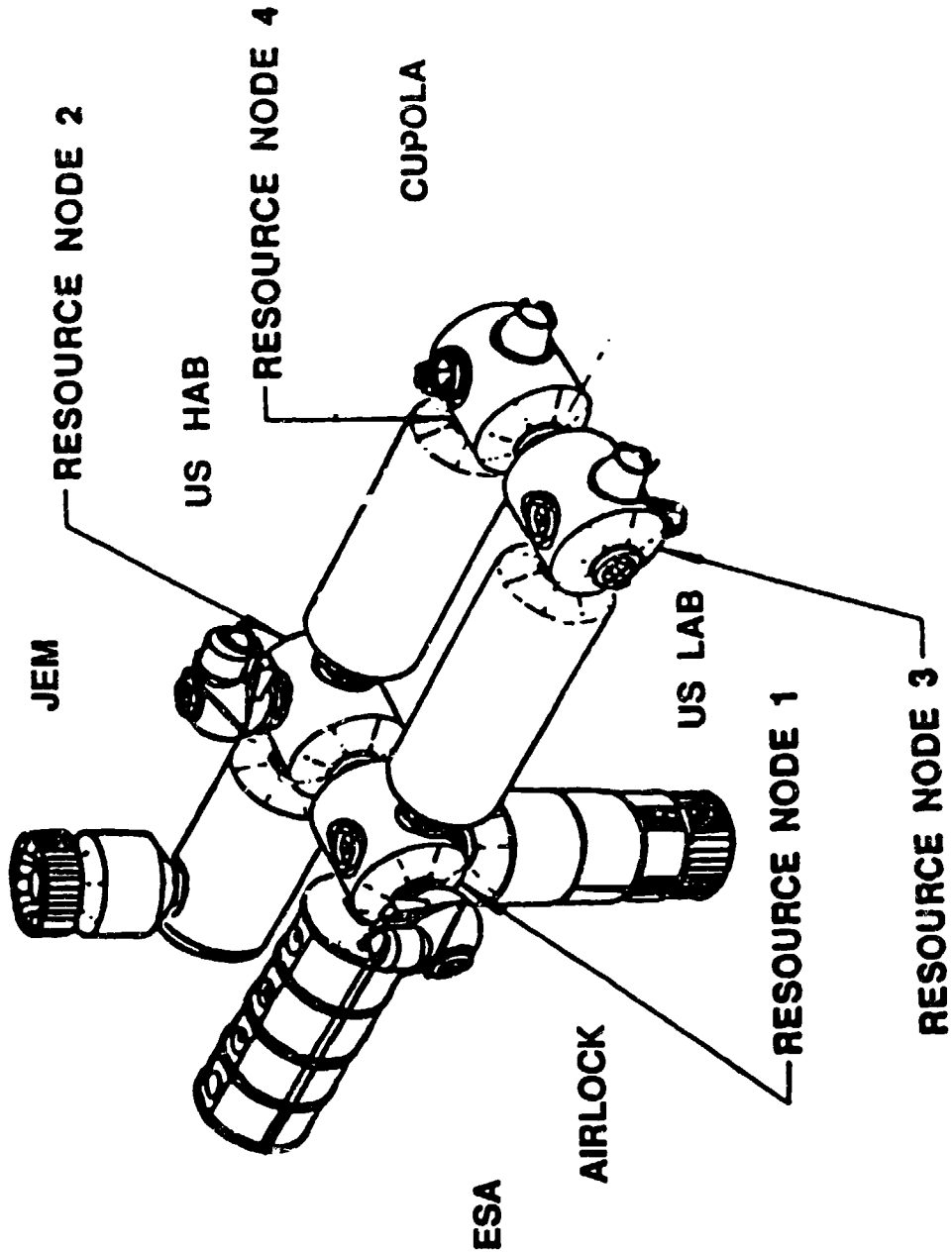

MODULE PATTERN

Sharing common structural concepts with the other Station modules, the resource node assembly provides additional volume to locate Station subsystems and equipment. Micro-meteoroid and debris shielding is incorporated into the outer shell to provide protection for the crew. Attached to one of the resource nodes is an airlock with one atmosphere and hyperbaric (six atmospheres) capability.

STRUCTURES / MATERIALS

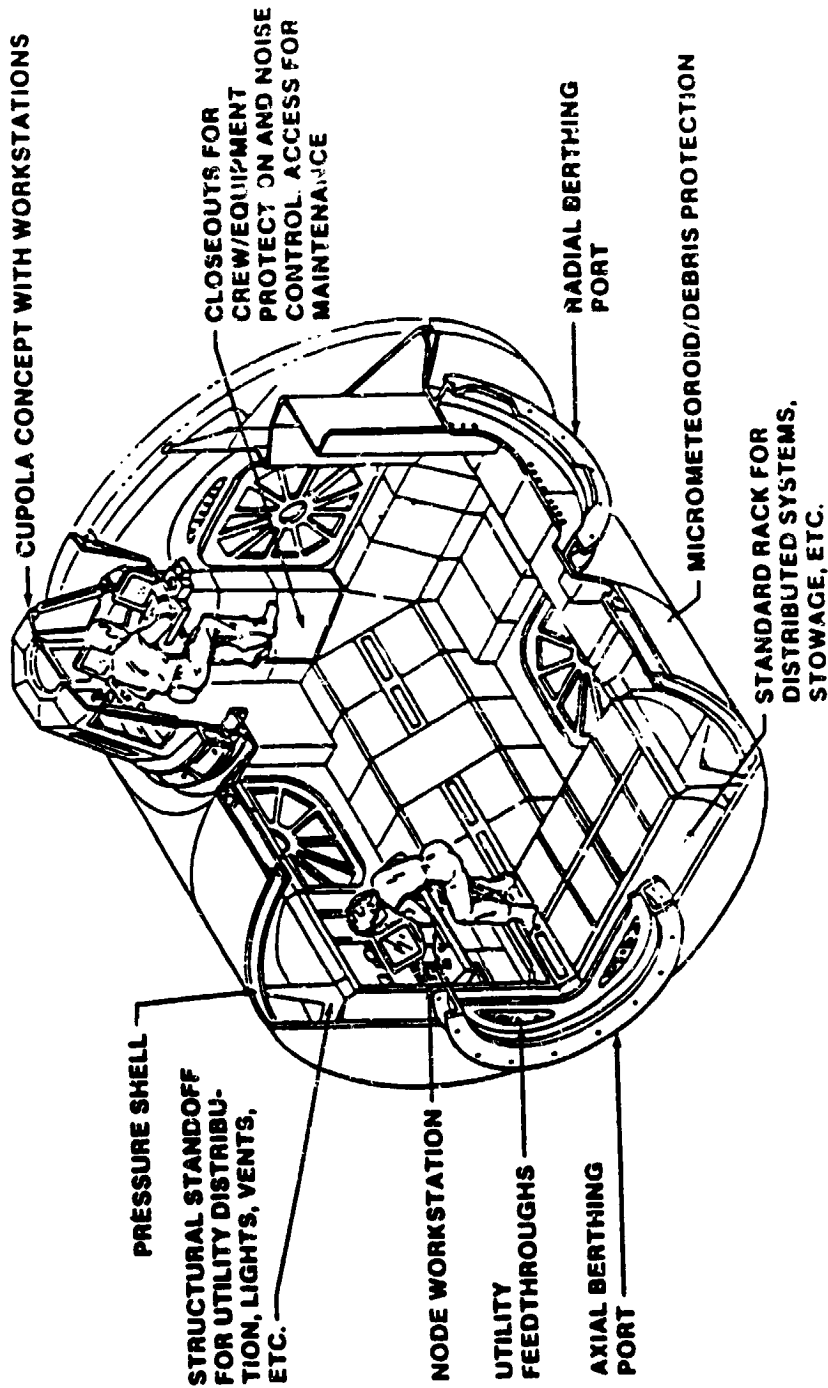

RESOURCE NODE

STRUCTURES / MATERIALS

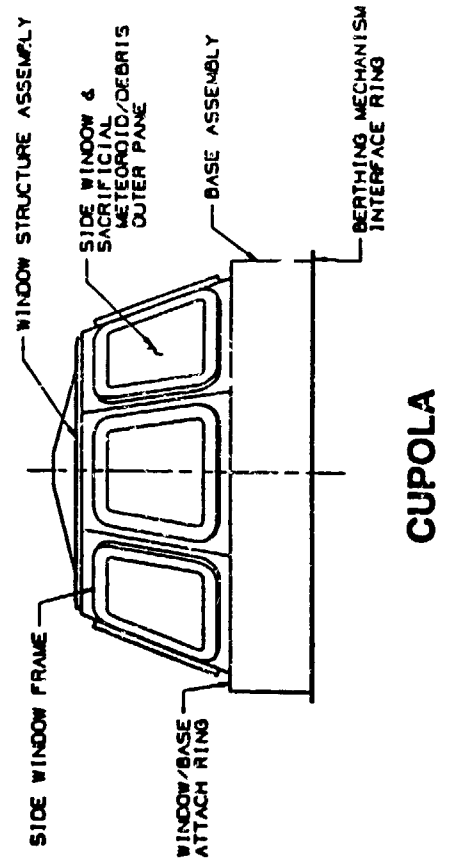
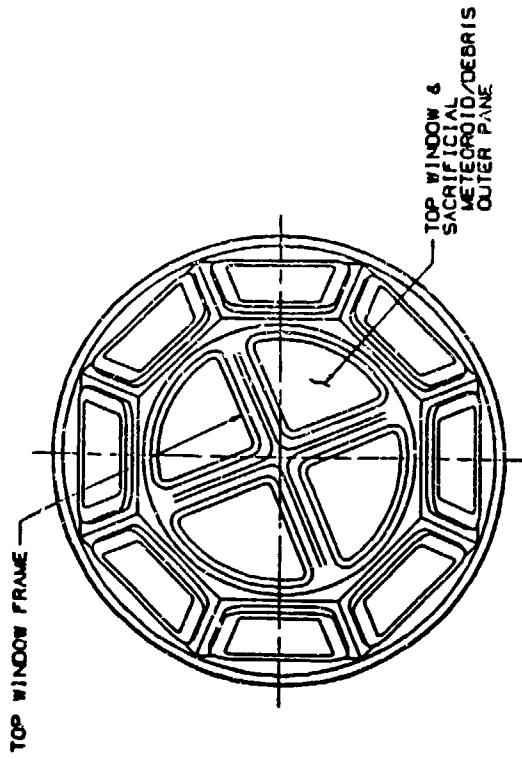

36

██████████

Assembling the Space Station requires hardware developed and built at one work package to be integrated into hardware produced at another work package. The WP-02 development of the module to truss interface structure will be integrated into the module design of WP-01. Similarly, transition hardware that connects the WP-04 alpha joint to the WP-02 truss must be developed from controlled interfaces. WP-03 and WP-02 require agreements for the proper design of hardware that integrates attached payloads to the truss structure. The development of the transporter base (upper and lower) must be coordinated with Canada to insure the proper operation of the top level assembly. Ultimately, each subsystem or Station component must integrate to the primary truss structure for on-orbit support.

KEY TECHNICAL CHALLENGES

APPROACH TO CHALLENGES

- 30 YEAR CERTIFICATION OF NON-METALLIC STRUCTURES
 - ATOMIC OXYGEN FLIGHT EXPERIMENT
- TRUSS
 - DEGRADATION STUDIES/COATINGS
- MOBILE TRANSPORTER
 - MATERIAL PROPERTIES DATA BASE DEVELOPMENT
- METEROID AND DEBRIS PROTECTION
 - LIGHT WEIGHT SHIELDING CONCEPTS
- FOR STATION COMPONENTS
 - ADD-ON PROTECTION (10 YEAR INCREMENTS)
- ON-ORBIT ASSEMBLY
 - GROUND TESTS
- DEVELOPMENT AND CERTIFICATION OF HIGH PRESSURE TANKS
 - POTENTIAL FLIGHT TESTS (CETA RAIL)
 - ON-GOING DEVELOPMENT OF DATA BASE

INTERFACES WITH OTHER SUBSYSTEMS/ELEMENTS

- **THE PRESSURIZED MODULES ATTACH TO THE TRUSS AT THE CENTER OF STATION
MODULE TO TRUSS INTERFACE STRUCTURE**
- **THE PALLETS ARE THE MEANS OF MOUNTING SUBSYSTEMS ON THE TRUSS**
- **THE CABLE TRAYS AND CETA RAIL ARE MOUNTED ON THE TRUSS BATTENS**
- **THE ALPHA ROTARY JOINT IS ATTACHED THE TRUSS WITH UNIQUE SET OF STRUTS**
- **THE PRESSURIZED COMPONENTS ARE MATED WITH COMMON BERTHING MECHANISMS
(INCLUDING THE INTERNATIONAL PARTNERS)**
- **THE CANADIAN MSC IS ATTACHED TO THE MOBILE TRANSPORTER**

ACCOMPLISHMENTS TO DATE

- **PROTOTYPE HARDWARE FOR 5 METER TRUSS BUILT AND TESTED**
EXTENSIVE WETF TESTING OF TRUSS COMPONENTS
TRUSS TUBE VENDOR SELECTED
- **MODULE TO TRUSS INTERFACE STRUCTURE CONCEPT UNDER REVIEW**
- **COMPLETED INITIAL LOAD ANALYSIS (INCLUDES DOCKING AND PLUME IMPINGEMENT)**
- **PRELIMINARY DESIGN IN WORK FOR PRESSURIZED STRUCTURES**

AIRLOCK
NODES
CUPOLA
MODULES

MECHANICAL SUBSYSTEM

MECHANICAL SYSTEMS DESCRIPTION

1. ORBITER TO STATION ATTACHMENT (DOCKING MAST) PROVIDES RIGID STRUCTURAL CONNECTION WHILE MAINTAINING PRESSURIZED CREW AND SELECTED EQUIPMENT TRANSFER
 - IN ORDER TO ENHANCE ORBITER DELIVERY CAPABILITY, MOST OF ATTACHMENT IS LOCATED ON STATION
2. UNPRESSURIZED BERTHING SYSTEM ATTACHES LOGISTIC MODULES TO TRUSS AT 3-POINTS USING LONG ALIGNMENT GUIDE LATCHES
3. SOLAR ALPHA ROTARY JOINTS PROVIDE POINTING CORRECTIONS FOR ELECTRICAL POWER SYSTEM WHILE TRANSFERRING POWER AND DATA
4. THERMAL RADIATOR ROTARY JOINTS POINT CENTRAL RADIATOR PANELS WHILE TRANSFERRING FLUIDS, POWER AND DATA
5. MOBILE TRANSPORTER PROVIDES TRANSLATION, ROTATION AND PLANE CHANGE MOBILITY FOR CANADIAN MOBILE REMOTE SERVICER

MECHANICAL SYSTEMS DESCRIPTION (concluded)

6. **DEPLOYABLE ASSEMBLY WORK PLATFORM WITH ASTRONAUT POSITIONING (3-DOF) SYSTEM MOUNTED ON MT TO PROVIDE CAPABILITY FOR TWO CREW MEMBERS TO ASSEMBLE STATION TRUSS FROM CARGO BAY OF ORBITER**
 - **UNPRESSURIZED DOCKING SYSTEM ON PLATFORM TO SUPPORT ORBITER TO STATION ATTACHMENT FOR STATION ASSEMBLY AND CREW TRANSFER VIA EVA**
7. **UTILITY SPOOL PROVIDES STS PACKAGING, SUPPORT, AND RESTRAINT DURING LAUNCH AND ON-ORBIT DEPLOYMENT DURING TRUSS ASSEMBLY**

48

REF ID: A600102

MECHANICAL SYSTEMS

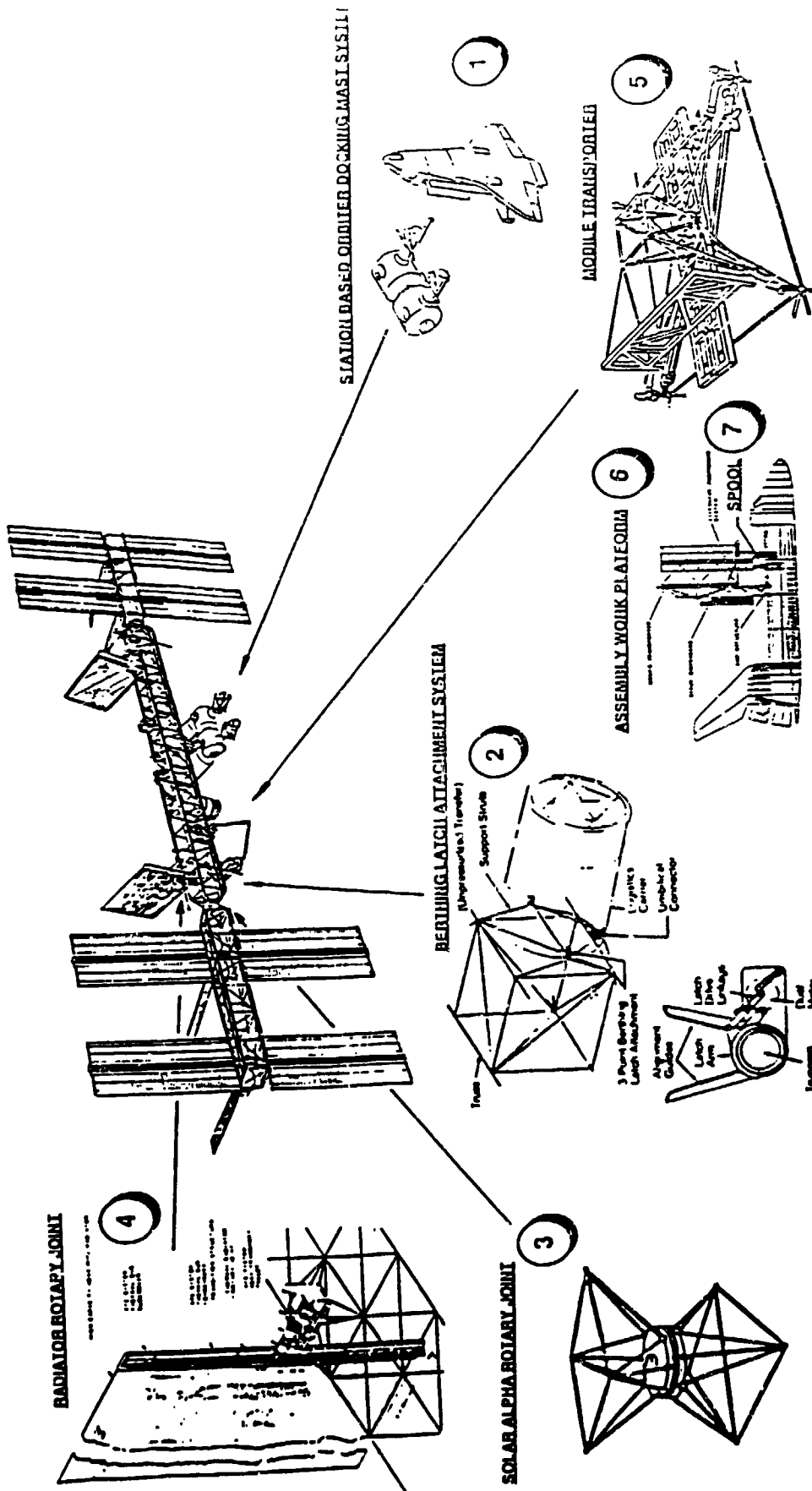

MECHANICAL SYSTEMS MAJOR TRADES

- ACTIVE ELECTROMECHANICAL ACTUATOR DEMONSTRATED BY MDAC ADVANCED DEVELOPMENT HARDWARE
- ORBITER TO STATION DOCKING MAST SYSTEM CONCEIVED BY JSC
- DOCKING MAST CONCEPT USING ACTIVE ELECTROMECHANICAL ACTUATOR PROBE/DROGUE SYSTEM CONCEIVED BY MDAC
- DOCKING MAST CONCEPT USING PASSIVE INDEPENDENT AXIS ATTENUATION SYSTEM CONCEIVED BY ROCKWELL INTERNATIONAL

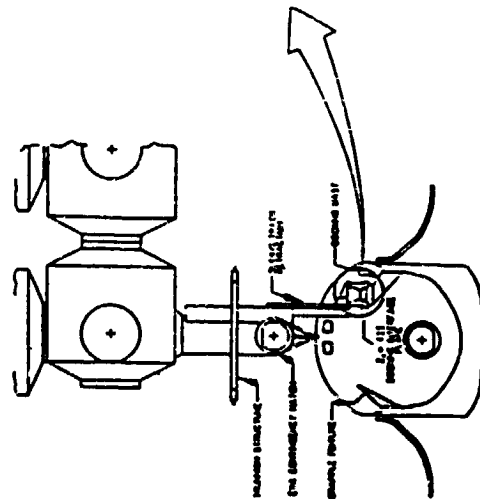

o CANDIDATE DOCKING MECHANISM DESIGN CONCEPTS

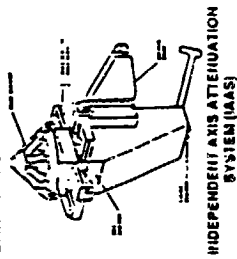

INDEPENDENT AXIS ATTENUATION SYSTEM (IAAS)

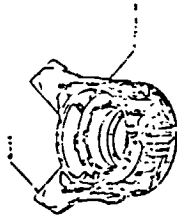

ASIP TYPE (PASSIVE)



ELECTROMECHANICAL ASIP TYPE (ACTIVE)

HYBRID SYSTEMS

52
INTENTIONALLY BLANK

THE DOCKING MECHANISM

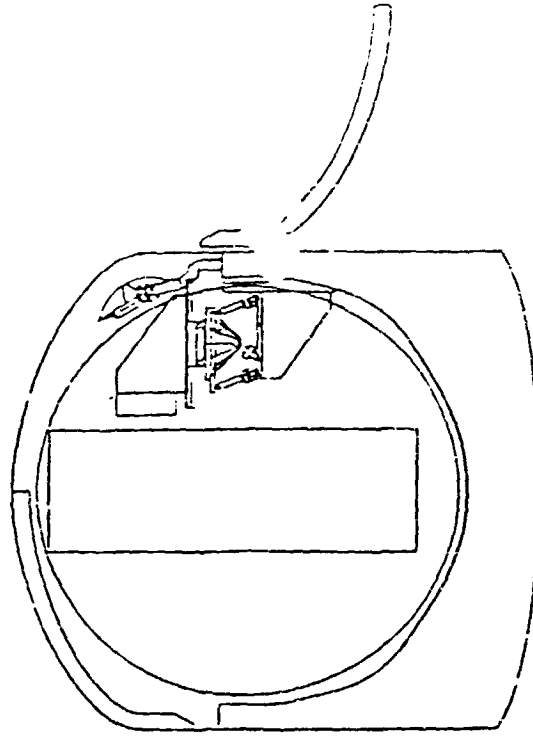

DOCKING MECHANISM MOUNTED
IN THE ORBITER (FIRST LAUNCH CONFIG)

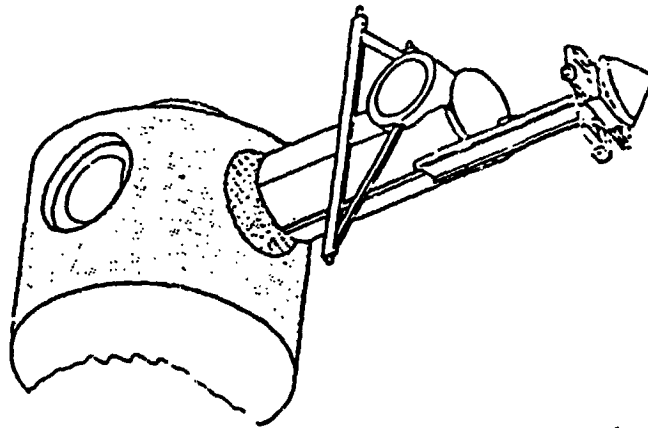
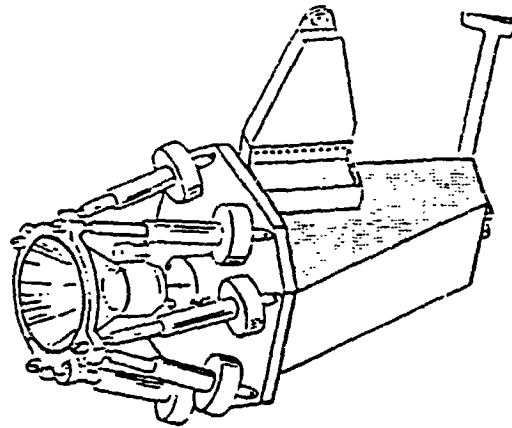

• DOCKING AND BERTHING

- DOCKING MAST MOCK-UP TESTS IN THE ORBITER FULL FUSELAGE TRAINER (BUILDING 9A/ JSC)
- DESIGN, FABRICATION, INSTALLATION AND CHECK OUT HAVE BEEN COMPLETED.
- ES/ROCKWELL DOCKING INTERFACE MECHANISM STUDY
- ES6 TASKED TO FORM A TEAM TO EVALUATE THE DOCKING MAST MECHANISM CONCEPTS AND SELECT THE SYSTEM BEST SUITED FOR DOCKING AND BERTHING. COMPLETED ACTIVITY IN MID APRIL 1989.
- TESTING OF MDAC ADVANCED DEVELOPMENT HARDWARE ON 6 DOF DYNAMICS SIMULATOR (BUILDING 13/ JSC)
- DESIGN AND FABRICATION COMPLETED

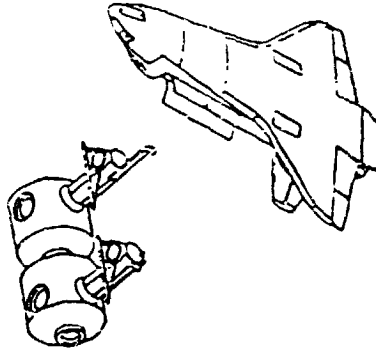

• MOBILE TRANSPORTER

- REVISED REQUIREMENTS
 - AUTONOMOUS MT DELETED
 - RF TO MT/MRS DELETED
 - PLANE CHANGE SCARRED FOR PMC / REQUIRED FOR AC
- CONTRACTOR PLANNING TO RETAIN PLANE CHANGE FOR PMC
- MT/MRS STRUCTURAL INTERFACE CONCEPT DEFINED
- PROGRAMATIC RESPONSIBILITIES IN WORK
- STOWAGE ENVELOPES FOR APS AND BATTERIES ESTABLISHED

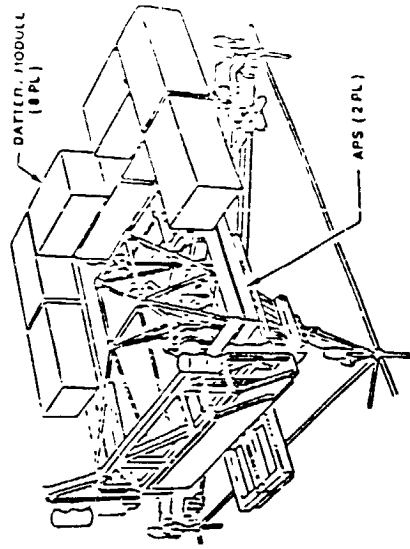
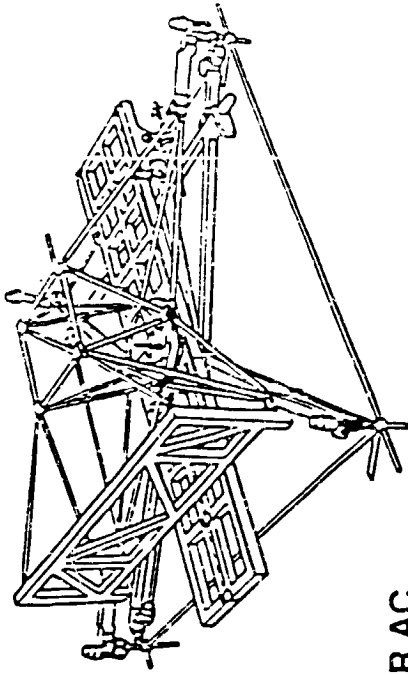

• ROTARY JOINTS (SARJ & TRRJ)

- PRELIMINARY DESIGN
- SUBCONTRACT PREPARATIONS & NEGOTIATIONS
- PDR PREPARATIONS
- DEFINE SOFTWARE FUNCTIONAL REQUIREMENTS
- DEFINE SIMULATION SOFTWARE
- DESIGN SPECIAL TEST EQUIPMENT

• SOLAR ALPHA ROTARY JOINT (SARJ) ACTIVITIES

- ELECTRONIC CONTROLS PRELIMINARY DESIGN
- STIFFNESS VS SIZE VS WEIGHT TRADE STUDIES
- BEARING DESIGN & LUBRICATION STUDY

• THERMAL RADIATOR ROTARY JOINT (TRRJ) ACTIVITIES

- ROTARY FLUID COUPLER PRELIMINARY DESIGN
- PROOF-OF-CONCEPT ROTARY FLUID COUPLER
MANUFACTURE & ASSEMBLE
LMSC TESTING PHASE I & II

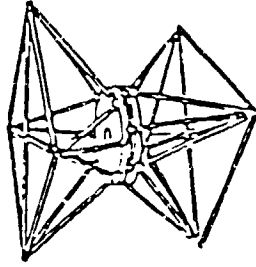

Solar Alpha Rotary Joint

- 138 Inch diameter
- Discrete trundle bearings
- Redundant drive system
- Roll ring power/data transfer
- 360° continuous rotation

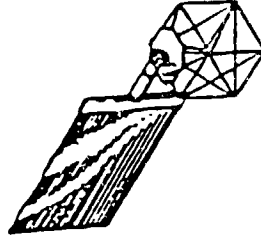

Radiator Rotary Joint

- 21-inch diameter angular contact bearing
- Rotary fluid coupling
- Roll ring data/power transfer
- +/- 100 degree rotation

60
INTENTIONALLY BLANK

- UNPRESSURIZED LOGISTICS CARRIER (ULC) ATTACH SYSTEM
- CONCEPTS FOR WP-1 & WP-2 DIFFERED DURING PROPOSAL
- ULC REQUIREMENTS FOR TYPE OF SUPPLIES AND THE LOCATION ON THE STATION ARE UNDEFINED.

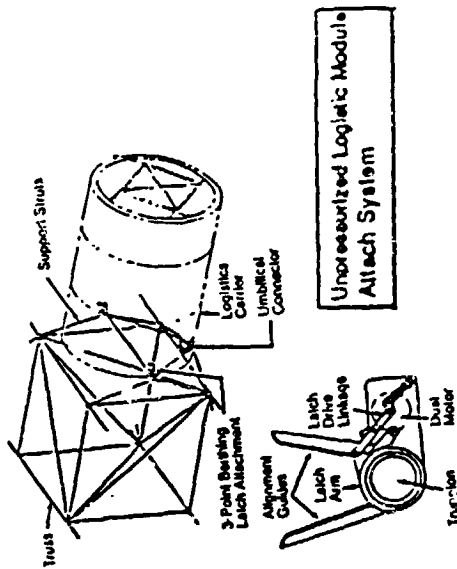

• OTHER MECHANISMS

• AIRLOCK HATCH

- CREW LOCK HATCH TRADE STUDY IS UNDERWAY TO SELECT A DESIGN CONCEPT

• ULC UMBILICAL MECHANISM

- BOTH WP-1 & WP-2 HAVE LEVEL III REQUIREMENTS

- RESOLUTION OF THIS OVERLAP IS BEING WORKED THROUGH PROJECT OFFICE

• ASTRONAUT POSITIONING SYSTEM (ON MT FOR USE ON AWP)

- DESIGN REQUIREMENTS ARE BEING DEFINED/UPDATED

- CONCEPTUAL LAYOUTS ARE COMPLETED

- DESIGN TRADES ARE BEING PERFORMED (JSC ASSY PLANNING & EVA WORKING GROUPS & MDSSC ENGR BOARD REVIEWED) (JSC MECHANICAL GROUP TO STUDY TRADES)

EVOLUTION ISSUES

- SSF IS EXPECTED TO GROW TO MEET EVER INCREASING REQUIREMENTS
- THE STRUCTURES SUBSYSTEM WILL HAVE TO ACCOMMODATE AND ENABLE STATION GROWTH REQUIREMENTS
 - PROVIDE ADDITIONAL STRUCTURE
 - INCREASE STRENGTH/STIFFNESS OF EXISTING STRUCTURE
 - REPAIR AND REPLACEMENT OF DAMAGED STRUCTURE
- METEROID AND DEBRIS PROTECTION IS AN ISSUE THAT PREVAILS DURING GROWTH PHASE
- THE STATION LEVEL OF ACTIVITY IS EXPECTED TO BE VERY EXTENSIVE, REQUIRING INNOVATIVE APPROACHES TO PROVIDING STRUCTURAL HARDWARE
 - SERVICING (PAYLOADS, OMV, PLATFORMS, etc.)
 - CONSTRUCTION ACTIVITIES (LARGE HEATSHIELDS, etc.)

66 INTENTIONALLY BLANK

STRUCTURES AND MECHANISMS

DISCUSSION SESSION

64 ~~XXXXXXXXXX~~

STATION EVOLUTION WILL RESULT IN EXTENSIVE CHANGES FOR THE STRUCTURES AND MECHANICAL SUBSYSTEMS. SOME OF WHICH ARE:

- LARGER STRUCTURES, ADDITIONAL MECHANISMS
- DIVERSE AND INCREASINGLY MORE COMPLEX SUBSYSTEMS TO ACCOMMODATE ON THE STATION STRUCTURE
- FREQUENT MODIFICATION OF THE STRUCTURAL AND MECHANICAL HARDWARE TO ACCOMMODATE THE NEW REQUIREMENTS

70

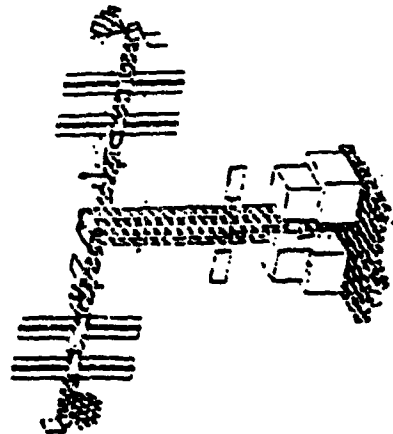
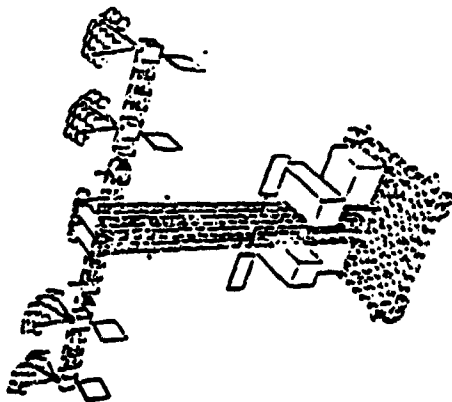
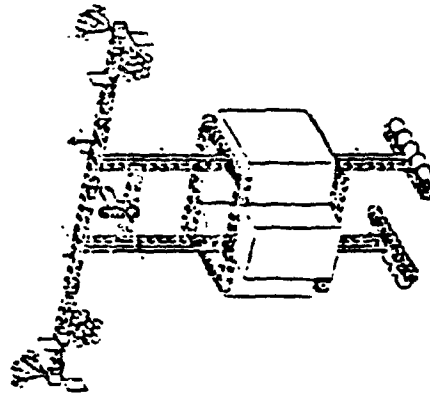
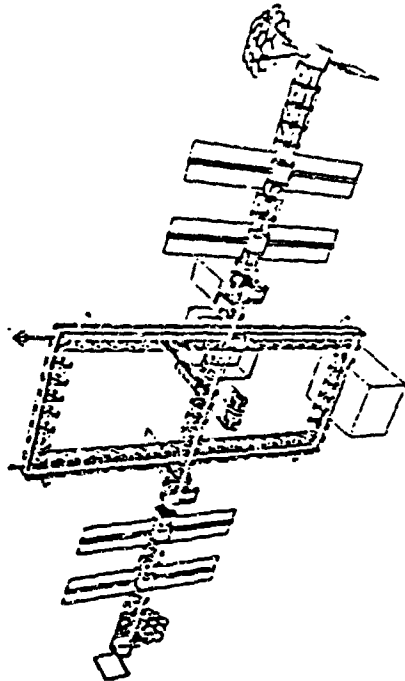
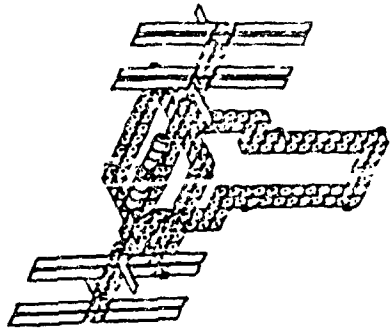

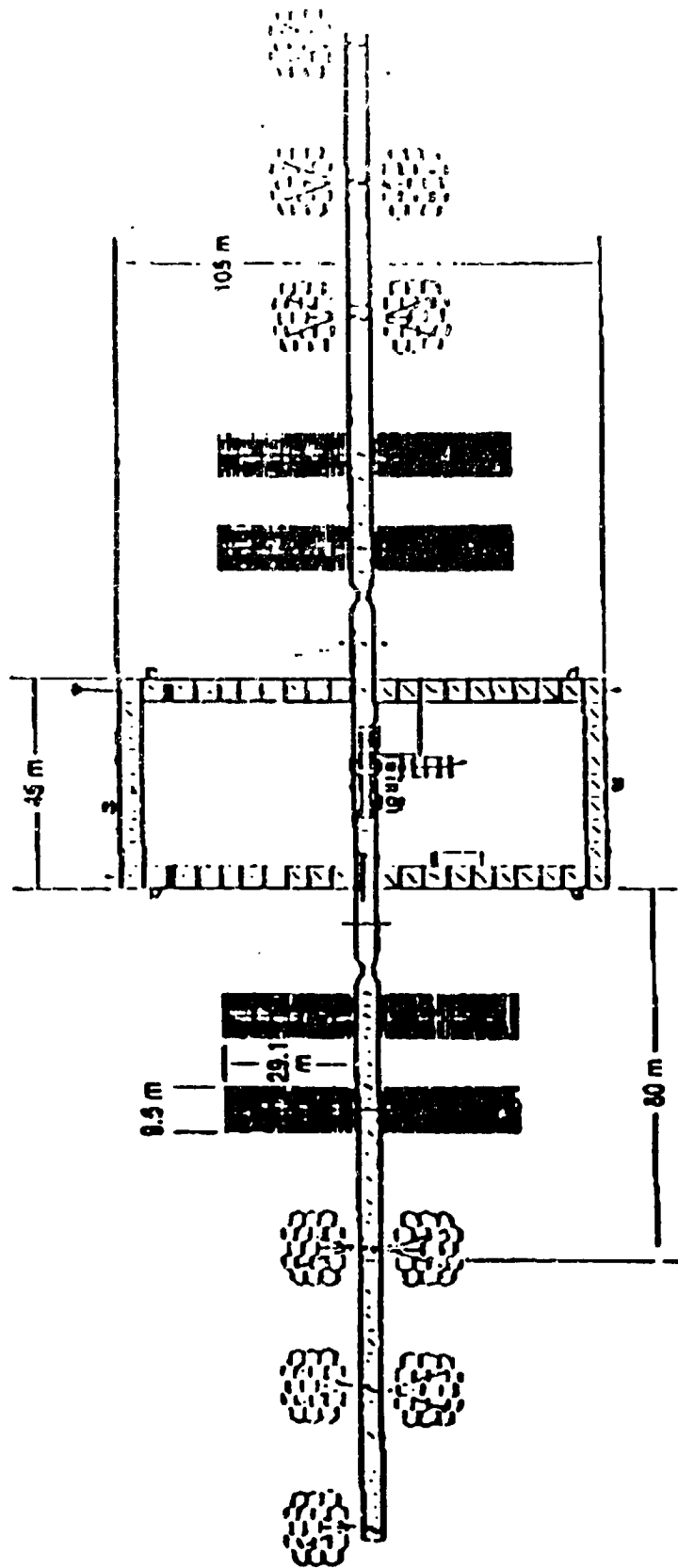
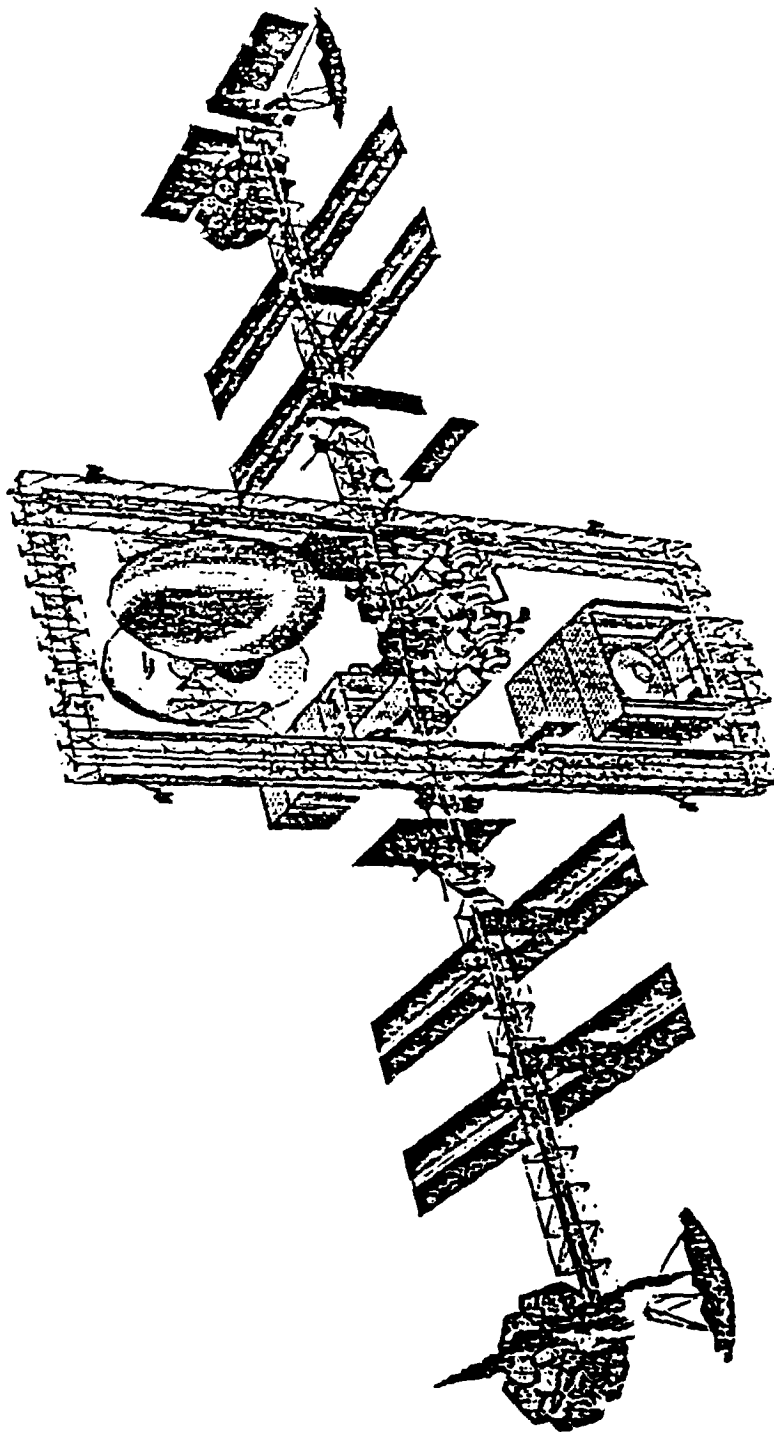

Figure 6.2-1. 325-kW Grow.h Power System



NASA/JSC
DR. KORNEL NAGY
713-483-8830

LaRC LUNAR/MARS TN

LaRC LUNAR TN

Mass: 612 mt

Hangar: 102,375 m³

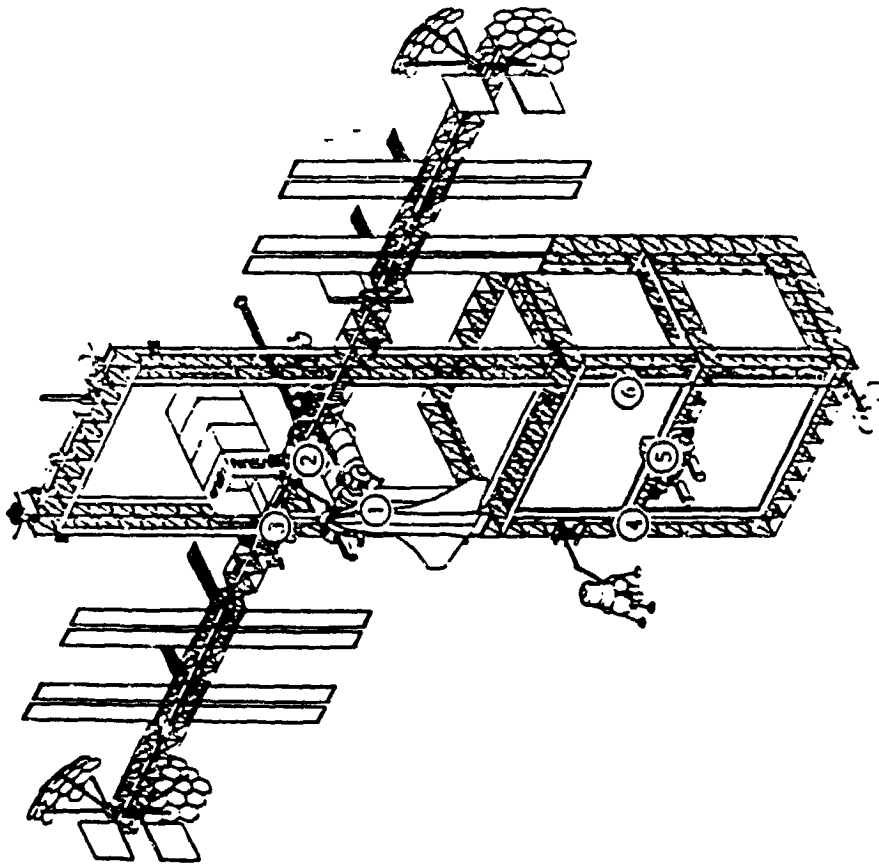

76

**• ISSUES AND CONSTRAINTS FOR EVOLUTION OF STRUCTURAL AND MECHANICAL
HARDWARE**

**• THE DESIGN OF THE HARDWARE IS PRESENTLY FOR THE PMC
CONFIGURATION**

- LOADS**
- SIZING**
- PERFORMANCE (DOCKING, BERTHING, etc.)**

**• OPPORTUNITIES FOR REPAIR AND SERVICING OF STRUCTURAL AND
MECHANICAL HARDWARE CAN BE SEVERELY LIMITED IN EVOLUTION PHASE BY**

- INCREASING NUMBER OF COMPONENTS**
- LIMITED CREW AVAILABILITY (EVA, IVA)**
- CREW WILL BE PERFORMING EXTENSIVE MISSION RELATED TASKS**
- LIMITED SPARES CAPABILITY**

8 INTERNATIONALLY BEARD

• ISSUES AND CONSTRAINTS FOR EVOLUTION OF STRUCTURAL AND MECHANICAL
HARDWARE (CONT'D)

- MINIMUM WEIGHT DESIGN IS A PERMANENT REQUIREMENT
- METEOROID AND DEBRIS PROTECTION IS A PERMANENT REQUIREMENT
 - MORE CHALLENGING WITH LARGER PAYLOADS
- THE MASS AND VOLUME OF PAYLOADS WILL INCREASE
 - OTV 100 TO 200 KLBS RANGE
 - LTV 400 TO 500 KLBS RANGE
 - MTV 1000 TO 1500 KLBS RANGE
- THE SERVICING OF LARGE VEHICLES MAY INCLUDE FUELING OPERATIONS
- THE MOVEMENT AND MANIPULATION OF LARGE PAYLOADS WILL
BE REQUIRED

**Structures/Materials
Invited Presentations**