

701

**THE MIDDECK ACTIVE CONTROL EXPERIMENT:  
GRAVITY AND SUSPENSION EFFECTS**

Dr. E. F. Crawley  
Dr. H. Alexander  
Mr. Daniel Rey

MIT  
MIT  
MIT

SERC Steering Committee Workshop  
January 22 and 23, 1992

59-29  
N93-27897  
p. 18

# ***OUTLINE***

- Motivation and Objectives
- Approach
- Overview of Gravity and Suspension Effects
- Modelling of Gravity and Suspension Effects
  - Effects on Structure
  - Effects on Sensors and Actuators
- Application to MACE
  - EM Configuration Study and DM Modelling
  - Objectives
  - Approach
  - Results
- Conclusions
- Future Work

# **GRAVITY AND SUSPENSION INFLUENCES**

## **Motivation:**

The need to perform closed-loop tests for performance verification of controlled structures and the reality of largely being limited to ground-based tests motivate the study of the impact of gravity and suspension effects on the closed-loop system behavior.

## **Objectives:**

To identify and understand the effects of gravity and of a suspension system on the dynamics of a controlled structure.

To develop and codify modelling techniques for the prediction of potential changes in the plant dynamics due to the presence or absence of gravity.

To develop rule-of-thumb predictions for the magnitude of the various gravity effects based on beam equivalent approximations of the suspended structure.

# ***APPROACH***

Motivate research with a simple example of gravity field perturbation to closed-loop performance.

Identify and categorize gravity and suspension system effects.

Develop an understanding of how to incorporate gravity effects into the system variational principle and its finite order approximation.

Verify modelling techniques by applying them to sample problems.

Perform parametric variation studies and experimental validation.

Develop rules-of-thumb for when gravity and suspension system effects become important for suspended structures.

# ***OVERVIEW: Gravity and Suspension Effects on Structure***

The following are direct effects on the structure and its model (i.e. the A matrix of the controlled structure model.)

GRAVITY FIELD EFFECTS	SUSPENSION SYSTEM EFFECTS
<p>1) FINITE DEFLECTIONS</p> <ul style="list-style-type: none"> <li>distributed gravity loads will cause initial deformations of the suspended structure.</li> </ul> <p>2) GRAVITY STIFFENING/DESTIFFENING</p> <ul style="list-style-type: none"> <li>distributed gravity loads stress the deformed structure which leads to eigenfrequency shifts and eigenmode coupling.</li> </ul>	<p>3) STATIC B. C. PERTURBATIONS</p> <ul style="list-style-type: none"> <li>static translational stiffnesses in the horizontal and vertical directions are prescribed by the suspension system at each attachment point.</li> </ul> <p>4) DYNAMIC B.C. PERTURBATIONS</p> <ul style="list-style-type: none"> <li>modal coupling with the suspension dynamic modes results in dynamic impedances at the attachment points.</li> </ul>
<p>5) DYNAMIC LOADING DUE TO GRAVITY FIELD AND SUSPENSION CONSTRAINTS</p> <ul style="list-style-type: none"> <li>dynamic torques which result from center of mass axis offsets with respect to the suspension support plane(s).</li> </ul>	

# ***OVERVIEW: Gravity Effects on Sensors and Actuators***

Sensors and actuators are also sensitive to gravity field effects.

Perturbations to their performance result in changes to the control, output and feed-forward matrices (i.e. B, C and D matrices) of the model. Two types of effects can be identified:

## **1) Direct Effects:**

The harmonic rotation of a translating mass device in a gravity field results in an additive perturbation to its ideal performance. To date, the only devices identified as being susceptible to this effect are the accelerometer and the proof-mass actuator.

Gravity loading can also result in non-ideal sensor and actuator performance; e.g. gravity induced friction in device.

## **2) Indirect Effects:**

Perturbations to the structure (i.e. the A matrix) can result in perturbations to the sensor and actuator performance depending on their location and the extent of the perturbation to the structure.

# **MODELLING OF GRAVITY AND SUSPENSION EFFECTS ON STRUCTURE**

## **Gravity**

The effect of a constant stress on a structure in equilibrium is to alter its stiffness.

In a FEM this change to the stiffness matrix can be called the differential stiffness matrix or the geometric stiffness matrix.

The geometric stiffness matrix is a function of the applied loading and to comprehensively incorporate the effect of gravity loading on the homogeneous system one should include its effects in the initial deformation calculations.

## **Suspension System**

The effects of the suspension system on the structural dynamics are captured by including the suspension system in the system model before incorporating the effects of gravity.

## ***Geometric stiffness theory and initial static deformation calculation***

The geometric stiffness matrix is obtained from the non-linear strain terms in the potential energy expression for an elastic structure in equilibrium:

$$U_p = \int_V \left\{ \frac{1}{2} (\epsilon_l^T E \epsilon_l + 2\epsilon_l^T E \epsilon_q + \epsilon_q^T E \epsilon_q) - (\epsilon_l^T E \epsilon_{l0} - \epsilon_l^T E \epsilon_{q0} - \epsilon_q^T E \epsilon_{l0} - \epsilon_q^T E \epsilon_{q0}) \right\} dV \\ + \int_V \{ \epsilon_l^T \sigma_0 + \epsilon_q^T \sigma_0 \} dV - \int_V u^T F dV - \int_S u^T \phi dS$$

For finite deflections the initial static deformation calculation is a non-linear problem as both the deflection and the stiffness are functions of the loads. Iterations are therefore required to solve for the final equilibrium state:

$$q_{i+1} = [K(q_i) + Kg(q_i, Q(q_i))]^{-1} Q(q_i)$$



# **MODELLING GRAVITY'S EFFECT ON ACCELEROMETERS AND PMAS**

Harmonic rotation of an accelerometer or proof-mass actuator about an axis other than the vertical axis or the device's sensitivity/actuation axis results in an additive perturbation to the device's output/input.

The harmonic rotation can be as a result of harmonic bending or torsional vibration of the supporting structure.

The output/input is either attenuated or amplified depending on the relative phasing of the coupled translation and rotation of the supporting structure, (with a possible phase reversal in the attenuation case).

In the case of torsion the output/input perturbation is about zero such that gravity makes torsional modes observable and gravity causes the PMA force actuator to induce torques.

The effects of gravity on the B and C matrices have been identified and non-dimensional sensitivity measures show that these effects are especially important at low frequencies but are only significant with near-horizontal oriented devices and at those points where the rotations are large with respect to the displacements.

# MODELLING GRAVITY'S EFFECT ON ACCELEROMETERS AND PMAs

The output of an accelerometer mounted to a beam in uncoupled bending and torsion vibration is given by:

$$a_i = \sum_{r=1}^{N_t} \left\{ (g \sin(\Phi_r^t(x_i)) \kappa_i^t) \eta_r^t(t) \right\} + \sum_{r=1}^{N_b} \left\{ (g \sin(\Phi_r^b(x_i)) \kappa_i^b - \omega_j^2 \Phi_j^b(x_i)) \eta_r^b(t) \right\}$$

In modal modelling terms this yields the following C matrix type terms:

$$X = \left[ \begin{array}{c|c|c} \eta^t & \eta^b & \eta^b \end{array} \right]^T \quad \begin{array}{l} C_{ij}^T = g \kappa_i^t \Phi_j^t(x_i) \\ C_{ij}^B = g \Phi_j^b(x_i) \kappa_i^b - \omega_j^2 \Phi_j^b(x_i) \end{array} \quad C = \left[ \begin{array}{c|c|c} C^T & 0 & C^B \end{array} \right]$$

The non-dimensional gravity effect ratio is thus:

$$\Gamma = \frac{g \hat{\Phi}_j^b \left( \frac{x_i}{l} \right) \kappa_i^b}{\omega_j^2 \hat{\Phi}_j^b \left( \frac{x_i}{l} \right)}$$

Similar expressions hold for the effective input of a PMA mounted to a beam in bending and torsion vibration.

# **APPLICATION TO MACE**

## **MACE EM Configuration Study**

### **Objectives:**

Select a MACE Engineering Model baseline configuration based on open-loop and closed-loop susceptibility to gravity and suspension effects.

## **MACE DM Modelling**

### **Objectives:**

Develop a high fidelity model of the MACE DM for use in control system design.  
Experimentally verify the gravity and suspension modelling techniques.

# MACE EM CONFIGURATION STUDY

## Approach:

- Develop set of 0g and 1g models of various fundamental MACE EM geometries.
- Study open-loop impact of gravity and suspension system using eigensystem and transfer function references.
- Study closed-loop impact of gravity and suspension system by applying LQG to system with PD stabilized bus attitude and gimbal pointing loops.

## Configurations studied:

Baseline - circular section struts, 1.7 Hz fundamental, payloads at 45° from vertical, planar system (i.e. suspension plane).

$f = 1$  Hz - stiffness change to obtain 1 Hz fundamental.

$EI_z/EI_y = 3$  - rectangular section struts, stiffened about z.

$EI_z/EI_y = 1/3$  - rectangular section struts, destiffened about y.

Out-of-plane - performance payload is swung 45° out-of-plane.

Flex. App. - flap-type flexible appendages added to node 1.

L-shaped - downward 90° bend is put in bus at node 2.



# MACE EM CONFIGURATION STUDY

## Sample Open-Loop Results:

**c5 - ONE g: MACE test article with Flexible Appage Pair**

Mode 17, Frequency 5.9100 Hz.

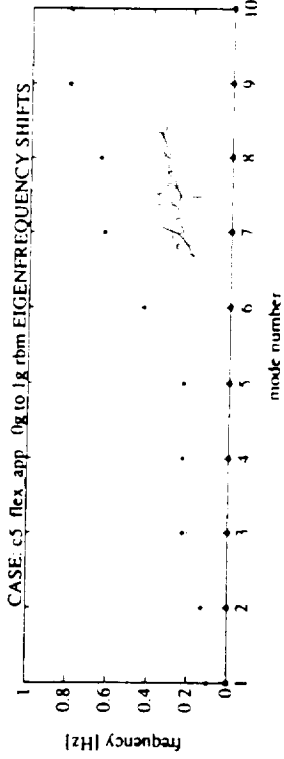
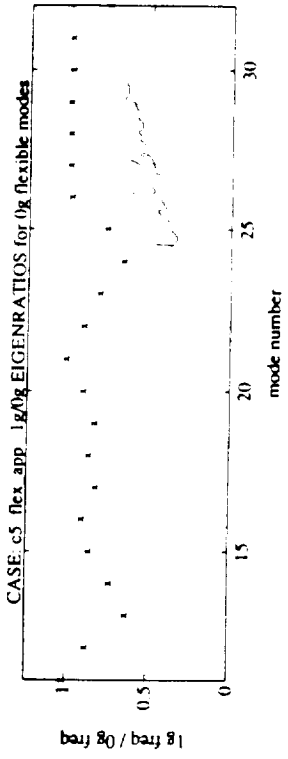
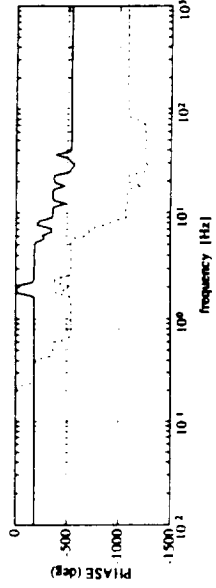
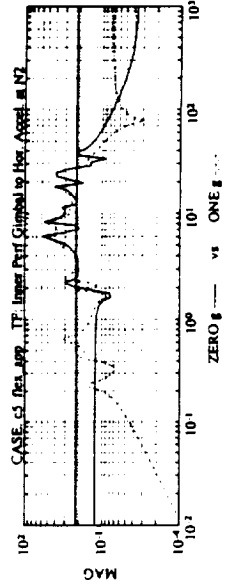
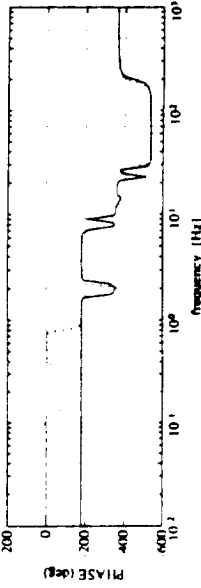
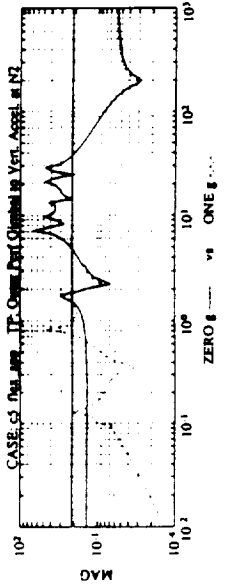
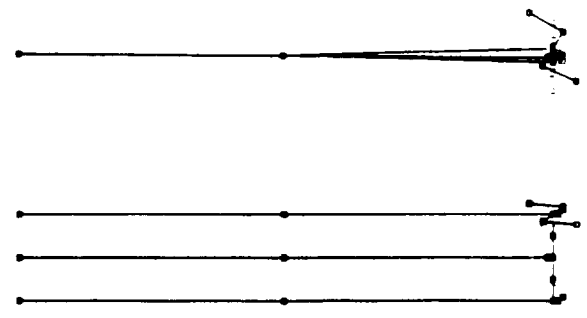

0g - 1g Modal Cross Orthogonality Mesh

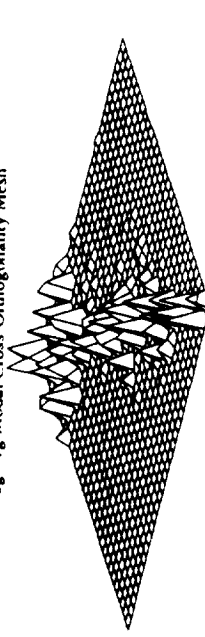

corner view

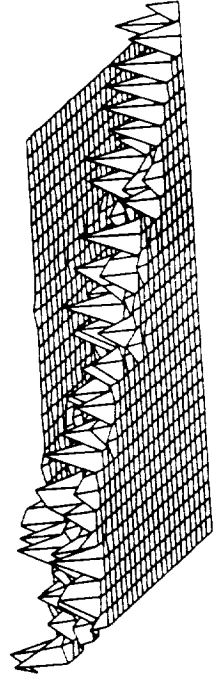

side view

# MACE EM CONFIGURATION STUDY

*Handwritten notes:*  
 1. The MACE EM configuration study is a study of the MACE EM configuration study.  
 2. The MACE EM configuration study is a study of the MACE EM configuration study.

## Sample Closed-Loop Results:

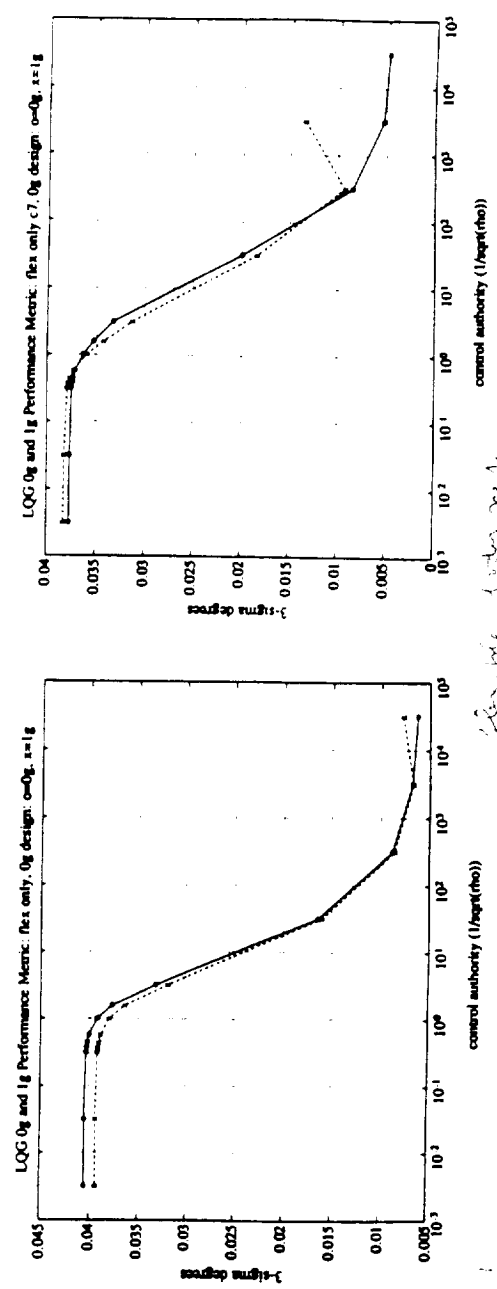
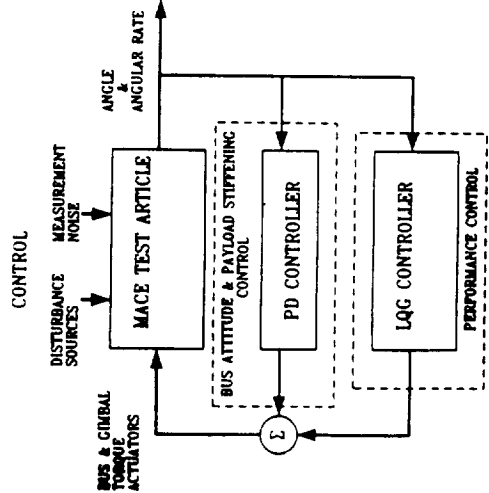
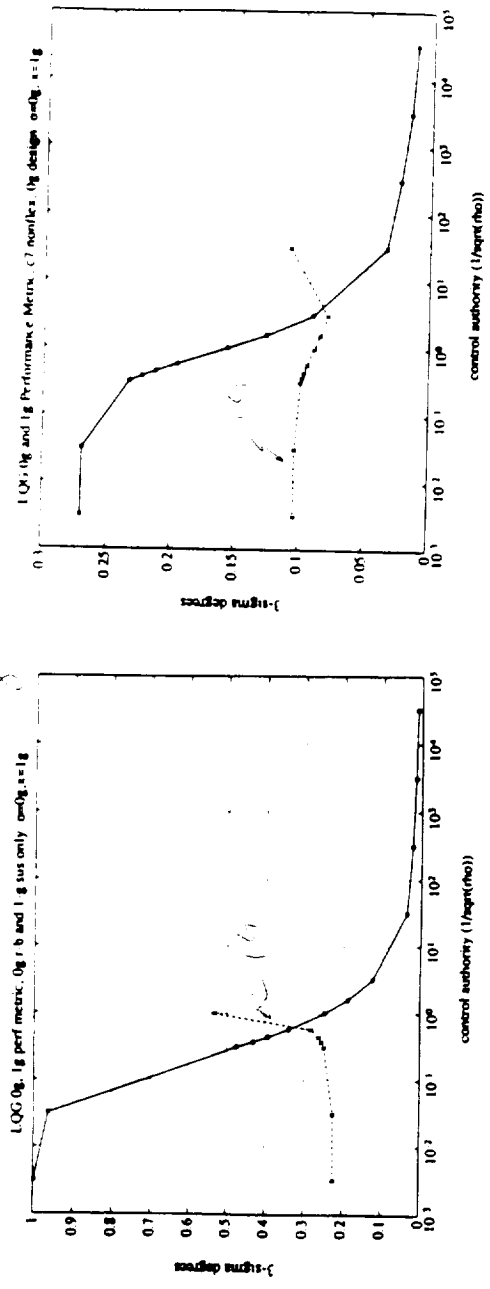
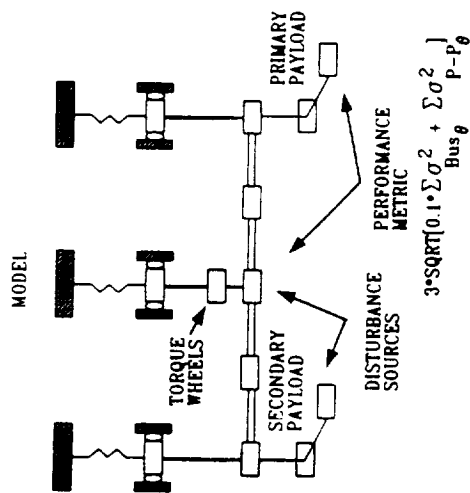

*Handwritten note:* flex only c7 only performance

# MACE DM CONFIGURATION STUDY

## Approach:

Add a basic model of suspension system to 0g model and incorporate static pre-deformation and geometric stiffening effects.

Model pneumatic-electric suspension devices as soft tuned springs between ceiling and suspension carriages, constrain suspension carriages to vertical translation and attach structure to carriages via stiff pinned-pinned rods.

Compare low-frequency modal I.D. data with predicted transfer functions and tune if required.

## MACE 1g DM Model Schematic:

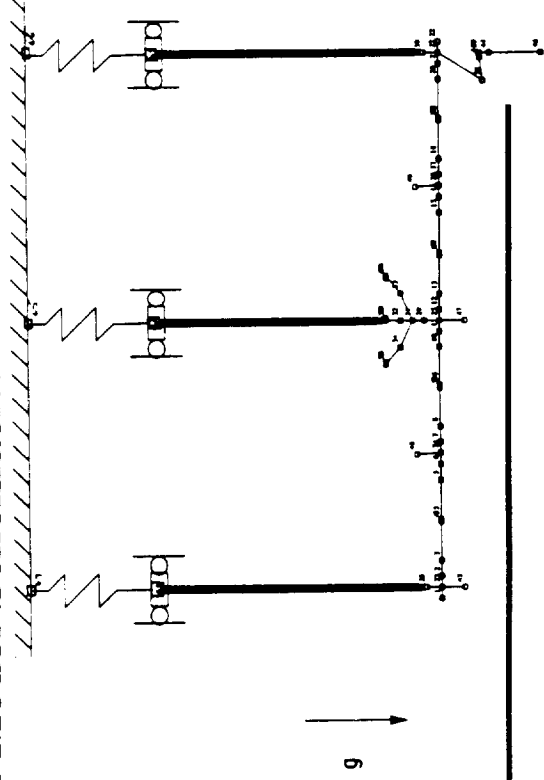

# MACE DM CONFIGURATION STUDY

## Status:

First iteration complete. Low frequency predictions have improved but some tuning is required including the addition of a higher order suspension model.

## Sample Transfer Function Results:

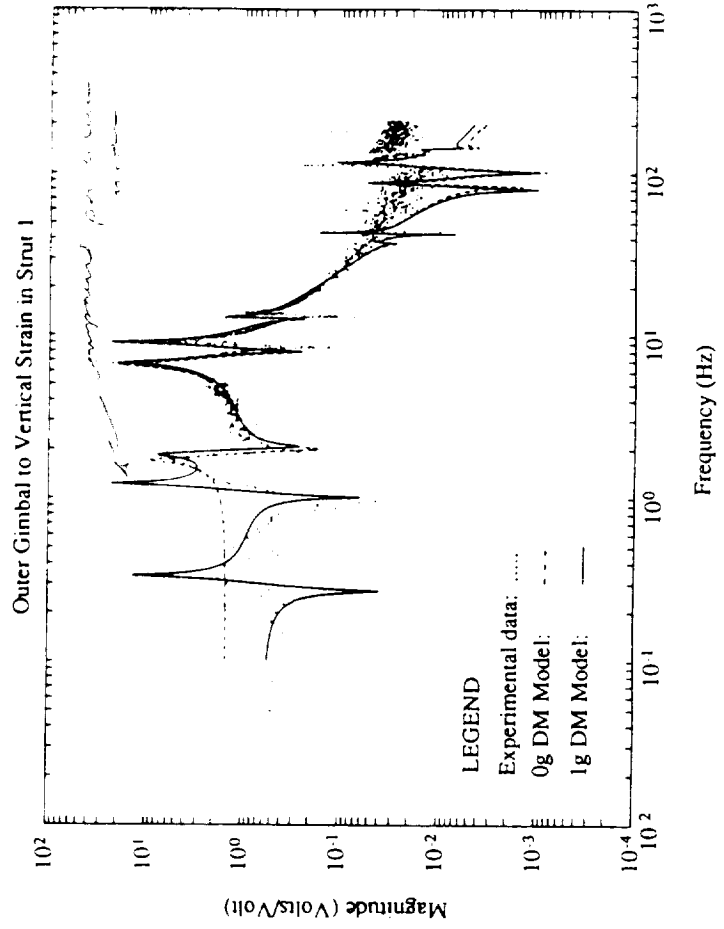
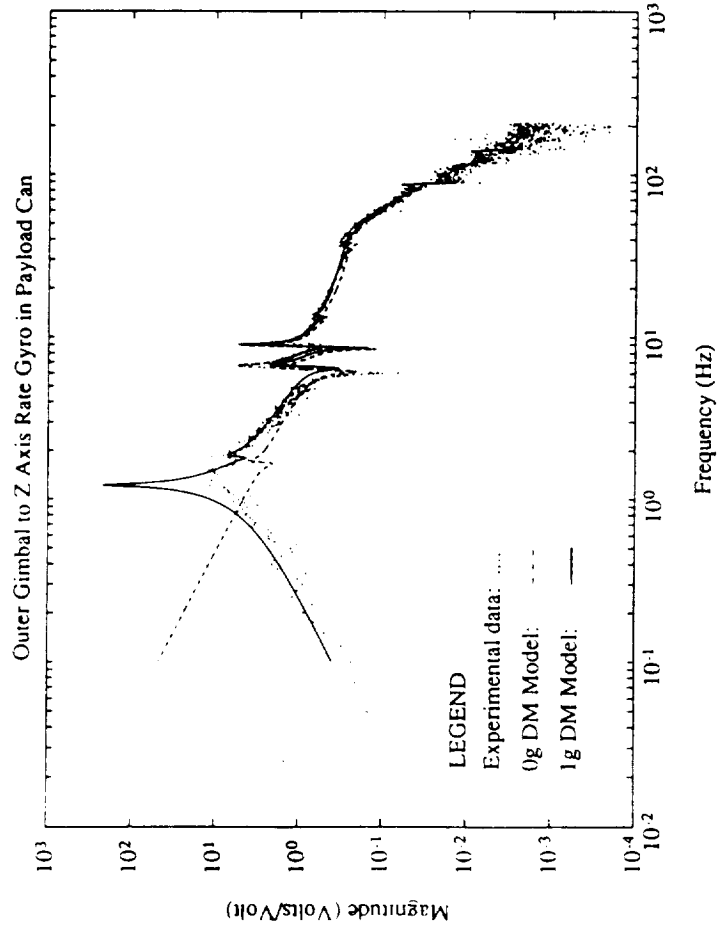



# **CONCLUSIONS**

The MACE test article is a valuable and effective test-bed for the research of gravity and suspension system effects.

The result of this research will be:

- a set of verified gravity effect and suspension system modelling techniques for application to detailed models of suspended controlled space structures, and
- a set of general gravity effect rules-of-thumb based on non-dimensional parameter descriptions of a suspended space structure.

# ***FUTURE WORK***

Paper - "Direct Effects of Gravity on the Control and Output Matrices of Controlled Structure Models."

Investigate impact of not reforming the mass matrix in the case of large deflections.

Tune the 1g DM model and continue experimental validation using the MACE test article.

Derivation of gravity/suspension effect rules of thumb.

S.M. Thesis - "Gravity and Suspension Effects on Controlled Structure Models"