

N93-27959

CHARACTERIZATION OF LUNAR SURFACE MATERIALS FOR USE IN CONSTRUCTION

Stewart W. Johnson, BDM International, Inc.

Jack O. Burns, Department of Astronomy, New Mexico State University

S3-91

158317

p. 6

Abstract

The Workshop on the Concept of a Common Lunar Lander, which was held at the NASA Johnson Space Center on July 1 and 2, 1991, discussed potential payloads to be placed on the Moon by a common, generic, unmanned, vehicle beginning late in this decade. At this Workshop a variety of payloads were identified including a class of one-meter (and larger) optical telescopes to operate on the lunar surface. These telescopes for lunar-based astronomy are presented in an earlier section of this report. The purpose of this section is to suggest that these and other payloads for the Common Lunar Lander be used to facilitate technology development for the proposed 16-meter Aperture UV/Visible/IR Large Lunar Telescope (LLT) (Bely et al., 1989; Nein, Davis, et al., 1991) and a large optical aperture-synthesis instrument analogous to the Very Large Array of the National Radio Astronomy Observatory (Burke, 1990; Burns et al., 1990a).

The Bahcall Report (1991) noted that the Moon is an excellent site for the above-mentioned and other astronomical observatories which would there be capable of making significant advances over terrestrial-based and free-flying orbiting telescopes. The Report went on to recommend that "NASA should initiate science and technology development so that facilities can be deployed as soon as possible in the lunar program" and "NASA should develop the technology necessary for constructing large telescopes...."

Many technologies are required for establishing these large telescopes on the Moon (Johnson and Wetzel, 1989; Burns et al. 1990b; Illingworth, 1990). Listed below are seven examples of technologies for these large telescopes which we feel deserve attention in planning payloads and operations of the common lunar lander.

1. Geotechnical (e.g., soils, excavation, and foundations).
2. Mitigation of Detrimental Environmental Effects (e.g., dust).
3. Construction.

4. Contamination/Interference Control.
5. Verification of Stable Precision Structures Performance on the Moon for Telescope Applications.
6. Optical Systems and Their Performance in the Environment.
7. Test and Evaluation of Systems for Lunar Observatories.

We will discuss each of the above listed seven technologies in turn and suggest how their development could be enhanced and accelerated by the common lunar lander program.

TECHNOLOGY DEVELOPMENT FOR LARGE LUNAR-BASED OBSERVATORIES: THE ROLE OF THE COMMON LUNAR LANDER

Technologies

1. Geotechnical engineering and associated technologies are required to properly support a large telescope on the lunar regolith, to provide in situ materials for shielding of sensitive telescope components (e.g., charged-coupled devices (CCDs), and to facilitate site characterization and preparation. It is essential to learn what design limitations are imposed by the strength and load-deformation characteristics of the regolith and its stability in excavations. Much was learned from the Apollo and predecessor programs about the regolith but the engineering information is still incomplete. The regoliths on the airless, dry, lifeless Moon developed from uniquely different processes than those on Earth which formed in the presence of oxygen, wind, water, and a wide variety of life forms. On the Moon the regoliths are formed by the continuous impacts of a full range of sizes of meteoroids and incessant bombardment by charged atomic particles from our sun and the stars. Doing geotechnical engineering for the large lunar telescopes will differ substantially from terrestrial applications and the penalty for miscalculation will be immense. We suggest that acquiring the following information be addressed with the lunar lander (Carrier, 1991):

Topographic maps of potential observatory sites (Carrier suggests 10-cm contours over an area 1 km in radius).

Detailed boulder sizes and counts over the same area.

Surveys (e.g., by radar, microwave or other means) for subsurface boulders over critical areas where foundations and excavation are desired.

Surveys of depth-to-bedrock (with suitable definition and characterization of bedrock).

Trenching and bulldozing experiments that establish energy requirements and depth limitations for these operations.

Drilling and coring experiments; with energy consumption and depth limitations quantified.

Force versus depth cone penetrometer measurements to be used for siting settlement-sensitive telescope structures.

Trafficability measurements including establishing energy consumption, slope climbing capabilities, and formation of ruts or depressed surfaces by repeated traverses of unprepared surfaces.

Electrostatic charge measurements.

Some of the above listed needs can be combined with proposed geophysical investigations.

2. Mitigation of detrimental environmental effects, including dust (Johnson et al., 1991) can be the subject of investigations using the common lunar lander. Dust transport mechanisms, both natural and equipment-related, should be established by direct measurements. The amount of dust levitated at the day-night terminator as by charge differences built up by photoconductivity effects (Criswell,

1972) should be determined. Predictions of effects of the radiation environment of the lunar surface on telescope components can be verified using common lunar lander components as well as revisits of equipment left on the Moon during the 1960s and 1970s. There is a need to quantify synergistic effects of environmental factors (e.g., vacuum, ultraviolet, micrometeoroid and secondary impacts, thermal cycling, and dust) on component viability. We need to ascertain the long-term effects of the lunar environment on thermal control coatings and polished surfaces. Also needed are ways of using the common lunar lander to validate that drives, vacuum and dust-sealed bearings, and other mechanical components for large lunar telescopes (and construction equipment) will function on the Moon in the presence of dust, radiation, thermal cycling, and vacuum.

3. Construction on the surface of the Moon of a 16-meter telescope and a Lunar Optical/Ultraviolet/Infrared Synthesis Array (LOUISA) will require that the geotechnical engineering and degradation abatement considerations in paragraphs 1 and 2 above be addressed. Information gathered from common lunar lander investigations in these areas will feed directly into answering questions as to how the construction process for the large lunar telescope should be accomplished. The geotechnical data listed is essential not only for planning site leveling (preparation) and the design of the telescope foundation but also verifying designs of the construction equipment to be used at the telescope site. *Figure 1* (Chua and Johnson, 1991) shows one proposed approach to large lunar telescope construction that illustrates some of the points of this paragraph. As part of the common lunar lander program, some simplified aspects of sensing and telepresence applicable to robotic construction of a large telescope can be investigated.

4. Contamination/interference control for a large lunar telescope will be essential. The one-meter class telescopes envisioned to become payloads for the common lunar lander should be instrumented to furnish data on their contamination and interference environments which will later be of value in designing contamination/interference control measures for the large lunar telescopes. Of interest are materials interactions and outgassing on the Moon, avoidance zones for other landings, dust (as previously mentioned), the communications and data relay noise, waste heat and radiation from power sources, stray light, and natural and machine-induced ground shock and vibrations (and regolith damping of these motions).

5. Stable precision structures technology will be a part of the small telescopes initially deployed on the Moon by the common lunar lander bus. Satisfactory performance of these structures will begin to provide the data base for larger and more complex telescopes to follow. Our suggestion is to design the small telescopes and their instrumentation so that the data returned will be relevant to the decisions that must be made on structures and materials for large telescopes.

6. Design of optical systems for performance in the lunar environment raises many questions which we can begin to answer with careful attention to detail in the design of the common lunar lander program and the one-meter class telescopes to be flown to the Moon as a part of that effort. One aspect to be considered is the performance of coatings for optics and thermal control. Also, a large telescope with a segmented mirror will require many actuators, a sensor and measurement system, and controls technology. Components of this scheme (in simplified form) could be tested on the Moon in the common lunar lander program.

7. Test and evaluation technologies for large lunar telescopes (e.g., a 16-meter segmented reflector and a LOUISA) will be an even greater challenge than they were for predecessor free-flyer telescopes in Earth orbit. We believe that the common lunar lander program offers a pathway to an early and systematic start on the testing program for simplified but relevant components of large lunar telescopes. To allow this path to be followed will require a break with some traditional ways of doing business. First it will be necessary to establish that there is a plan to eventually place a

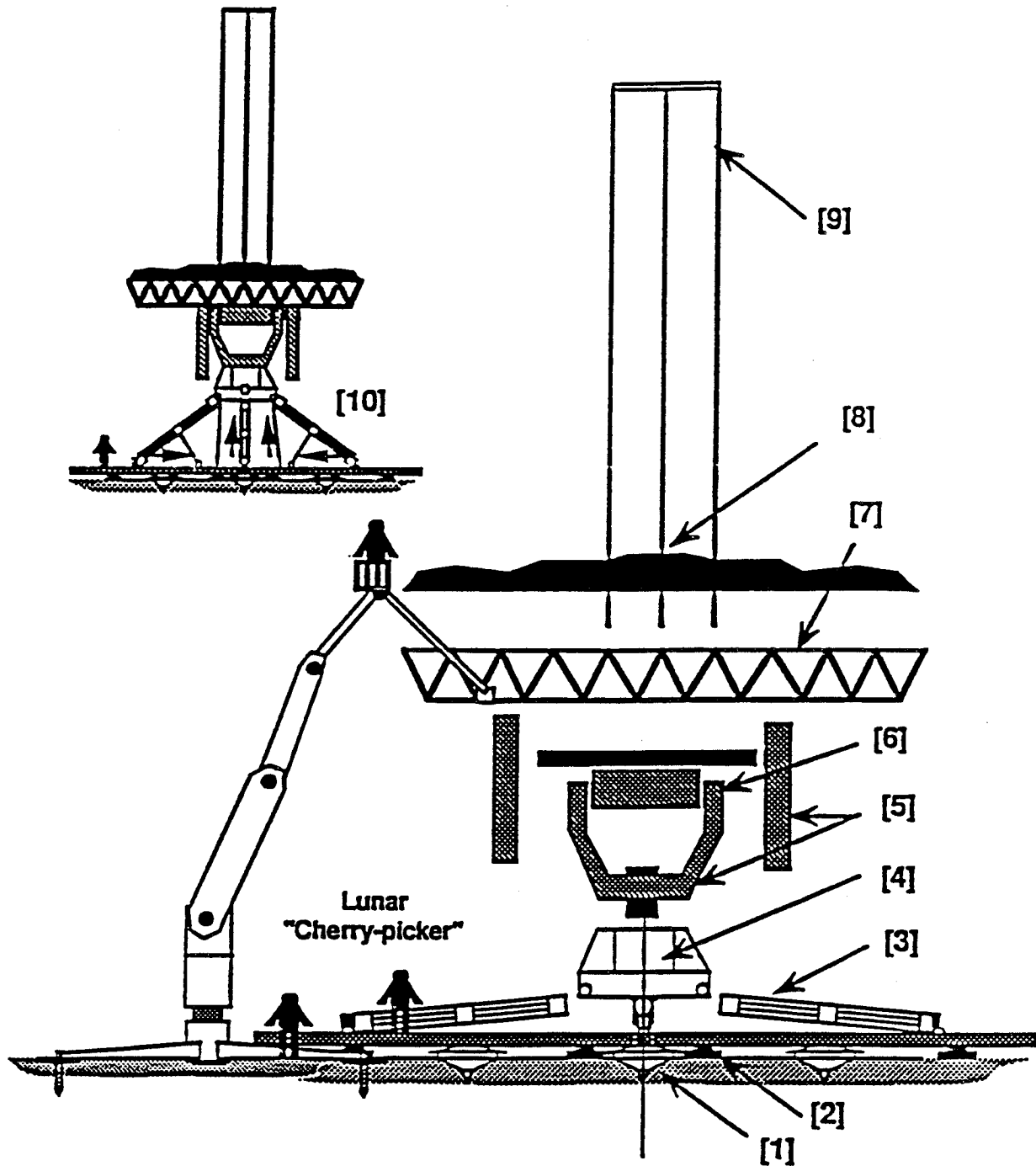

- [1] Install footings
- [2] Lay rails and temporary footings
- [3] Fabricate and place tripod legs along rails
- [4] Install azimuth drive assembly
- [5] Install yoke, shaft and counterweights

- [6] Install gimball ring and trunnion
- [7] Assemble Trusses
- [8] Place mirror assemblies
- [9] Install secondary mirror
- [10] Jack up LLT assembly

Figure 1. Proposed Construction Steps for the LLT

16-meter class telescope and a LOUISA on the Moon. It will also be necessary to have some agreement as to how these telescopes would be designed so that significant new technologies to be used could be conceptualized and (in simplified form) tested and evaluated on the Moon as part of the Common Lunar Lander Program.

Recommendation

The early lunar observatories of the one-meter class, and later lunar-based telescopes of increasing complexity, call for imaginative solutions to diverse problems in optics, controls, structures, geotechnical engineering, construction, and environmental engineering. We feel that the best pathway for solving these problems is through a long-term plan in which each step builds on the past. The common lunar lander program, as we have pointed out, offers the opportunity to take the first step.

Acknowledgements

We acknowledge the support of the National Aeronautics and Space Administration, New Mexico State University, the University of New Mexico, and BDM International, Inc. in this effort. Discussions with Max Nein and Billie Davis of NASA Marshall Space Flight Center (particularly regarding the 16-meter and precursor telescopes) have influenced our thinking in these areas.