

N 9 3 - 2 7 9 8 1

**Flexible Control Techniques for a Lunar Base**

**Thomas W. Kraus**

**Intec Controls Corporation**

**Abstract**

525-63

158339

P. 8

The fundamental elements found in every terrestrial control system can be employed in all lunar applications. These elements include sensors which measure physical properties, controllers which acquire sensor data and calculate a control response, and actuators which apply the control output to the process.

The unique characteristics of the lunar environment will certainly require the development of new control system technology. However, weightlessness, harsh atmospheric conditions, temperature extremes, and radiation hazards will most significantly impact the design of sensors and actuators. The controller and associated control algorithms, which are the most complex element of any control system, can be derived in their entirety from existing technology.

Lunar process control applications -- ranging from small-scale research projects to full-scale processing plants -- will benefit greatly from the controller advances being developed today. In particular, new software technology aimed at commercial process monitoring and control applications will almost completely eliminate the need for custom programs and the lengthy development and testing cycle they require.

The applicability of existing industrial software to lunar applications has other significant advantages in addition to cost and quality. This software is designed to run on standard hardware platforms and takes advantage of existing LAN and telecommunications technology. Further, in order to exploit the existing commercial market, the software is being designed to be implemented by users of all skill levels -- typically users who are familiar with their process, but not necessarily with software or control theory. This means that specialized technical support personnel will not need to be on-hand, and the associated costs are eliminated. Finally, the latest industrial software designed for the commercial market is extremely flexible, in order to fit the requirements of many types of processing applications with little or no customization. This means that lunar process control projects will not be delayed by unforeseen problems or last minute process modifications. The software will include all of the tools needed to adapt to virtually any changes.

In contrast to other space programs which required the development of tremendous amounts of custom software, lunar-based processing facilities will benefit from the use of existing software technology which is being proven in commercial applications on Earth.



## Introduction

Intec Controls is a seven-year-old company involved in designing, producing, marketing and selling process control software for the PC. Intec's products have been applied in many thousands of installations worldwide in a wide variety of different markets and applications. Although we have never installed any of our systems outside the planet Earth, it is important to recognize that the flexibility inherent in Intec-developed systems still applies.

This paper first covers the fundamental elements of close-looped control, pointing out that these basic concepts are as applicable on the Moon as they are on the planet Earth. Secondly, control system design is addressed, with emphasis on the flexibility that is inherent in a software package that uses graphical programming methods. Next, control hardware issues are discussed, with an emphasis on the flexibility and cost advantages of using standard hardware on a lunar base as opposed to proprietary hardware. Lastly, system reliability is addressed, pointing out the benefits of using control systems which have been heavily tested in thousands of installations on the planet Earth.

## Body

Closed-loop control has been around for many decades. Through that period of time, the PID (Proportional Integral Derivative) Controller has flourished and become the main workhorse in the process industry. The PID Controller is not used as heavily when we are talking about the control of advanced aerospace guidance or propulsion systems -- there are much more modern approaches to handling these systems. However, it is important to note that the power of PID is especially apparent when we are dealing with a process system that does not have vibratory nature and is subject to many non-linearities and many perturbations. In other words, when the process dynamics are not as well understood.

With the lunar base, we are dealing with processing many types of materials, extraction of oxygen from rock and other processes which involve chemistry, mechanics and thermodynamics. The fact that PID is so heavily used in process plants presently is testimony to its robustness, and I propose, its applicability to a lunar base. It has been proven repeatedly that the PID algorithm is robust, well adapted and able to handle a variety of situations. Furthermore, when one closes a control loop around a very unknown type of process and perturbs that loop by making a setpoint change or making a load disturbance, the closed loop dynamics is typically a damped oscillation when the loop is properly tuned. The exact details of the dynamics of the process does not matter--the PID makes these different processes behave very similarly. Actually, it allows the process dead time to be taken into account as well. Let us now move on and cover the applicability of using standard software for controlling the lunar base.

The first issue I would like to discuss is graphic programming language. As we see in *Figure 1*, graphic programming involves connection: the ability to specify various types of algorithms, put these algorithms down on the computer screen, and draw lines between them to represent the flow of data. When you click on any one of the algorithms, up pops a specification box which allows you to input the specific parameters necessary for the algorithms. The ease of use of graphic programming encourages free thinking. It quickly allows engineers to make changes as need be. Furthermore, the graphic programming allows better understanding of the control system and it also allows a more reliable system because when changes are made, we have connected, tested and understood algorithms instead of working with a large amount of custom code.

*Figure 2* shows a little more detail of graphic programming where a temperature control loop and a flow control loop are tied together through a low signal selector. In this particular case, we are typically controlling flow. However, if the temperature starts to rise too high, we will cut back on the flow in spite of the fact that we have not achieved it. It is this kind of graphic programming that

Figure 1

*Intuitive Software for Manufacturing Excellence*

# DESIGN AND ENGINEERING

## Graphic Programming Language

Easy to learn and use.

The screenshot displays the INTEC software interface. At the top, a menu titled "ADD TEMPLATE ( ADD )" is open, showing configuration options for a new template. The options are as follows:

TAG	=	FINAVG	UNITS	=	PCT
DESC	=	AVERAGE FLOWS			
HI RANGE	=	100.0000	SCAN	=	1.000000 Sec
LO RANGE	=	0.000000	HI LIMIT	=	100.0000
INPUT 1	=	E	LO LIMIT	=	0.000000
K1	=	0.500000	INPUT 2	=	E
			K2	=	0.500000

Below the menu, a ladder logic diagram shows two input boxes labeled "AIN" connected to an "ADD" block. The first input is labeled "1" and the second is labeled "2". The output of the "ADD" block is labeled "FINAVG". A mouse cursor is pointing at the "ADD" block. A callout box from the menu points to this diagram.

Click the mouse or Press Escape key to exit menu.

At the bottom of the screen, there is a toolbar with buttons for "ADD", "DEL", "DIV", "AVG", "AVGT", "EXPR", and "LIBRARY". The "LIBRARY" button is highlighted. The bottom right corner features the INTEC logo.

Figure 2

*Intuitive Software for Manufacturing Excellence*

# CREATIVITY AND INNOVATION

## Graphic Programming Language

**Natural language of engineers encourages free thinking.**

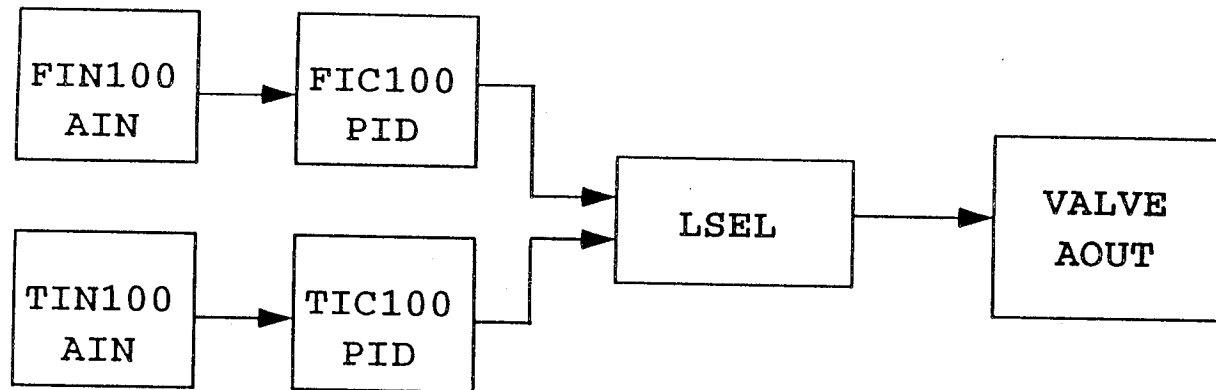

V-19



allows changes to be made by one engineer even though it was another engineer who initially specified the system and installed it years ago.

Another aspect of graphical programming is being able to nest functionality. The connected function blocks illustrated in *Figure 2* can be grouped into a single block and saved as a "compound" block. *Figure 3* illustrates how compounds can be nested inside one another. This allows engineers to construct algorithms based upon the standard function blocks, save this collection of blocks as a compound, and then use these algorithms over and over again as need be. In any system, including a lunar base, there is much symmetry. If there is one reactor, there are likely to be a half dozen or a dozen. So what we do to control one is directly applicable to the next reactor and the next one and so forth. The methods of graphic programming greatly simplify the task of replicating functionality.

What about the flexibility of standard hardware? What is meant by standard hardware is hardware that is based upon PC technology -- meaning mostly the Intel microprocessor. This paper does not attempt to comment on the details of cosmic radiation and so forth. However, it certain that by utilizing standard hardware, one is able to utilize a vast amount of standard software. By doing so, we greatly diminish not only the time to get a job done, but also the costs involved in performing a specified activity, as well as the quality and reliability of the software that goes into it.

As shown in *Figure 4*, by using standard hardware, we are even able to utilize standard local area network technology to move information from Point A to Point B in the lunar base. Furthermore, we are able to distribute processing and the CPU power necessary to make things happen. Also, such systems are upgradeable. With new technology, new hardware becomes available and you can utilize the same software or later versions of that software without having to redo the entire application. The benefits are tremendous. We are talking about 586 machines in the not too distant future.

Standard hardware also gives us a degree of openness. Openness to connect between various types of hardware, again using standard software. Functions such as alarms and reports can all be done in a straight forward manner without special coding. Standard hardware also allows us, as shown in *Figure 5*, to utilize methods and techniques that are very applicable in other industries and directly utilize them for the lunar base again where appropriate.

As discussed previously, another benefit of utilizing standard software is the reliability issue. Because such software has been tested in literally thousands of installations, one can be assured that when conditions change in the lunar base, creating situations beyond those covered by the normal testing that might have been done on commissioning of the system, it is highly unlikely that there will be some sort of severe breakdown. It is more than likely that someone has applied the system in these unexpected conditions in one of the thousands of Earthbound applications. If a system is put together just for a lunar base, it does not receive the same degree of testing -- it is impossible. So applying standard industrial software has strong advantages -- the concepts work and are very applicable to a lunar base.

## **Summary**

In conclusion, the proven methods of control, namely the PID controller and other algorithms, still apply for a lunar base as they have applied for many years on the planet Earth. Second, graphic programming language gives a high degree of flexibility and also has a high degree of reliability from a software point of view. By utilizing standard hardware, we are able to greatly reduce the system cost and again contribute to reliability.

Figure 3

## DESIGN AND ENGINEERING

### Compounds

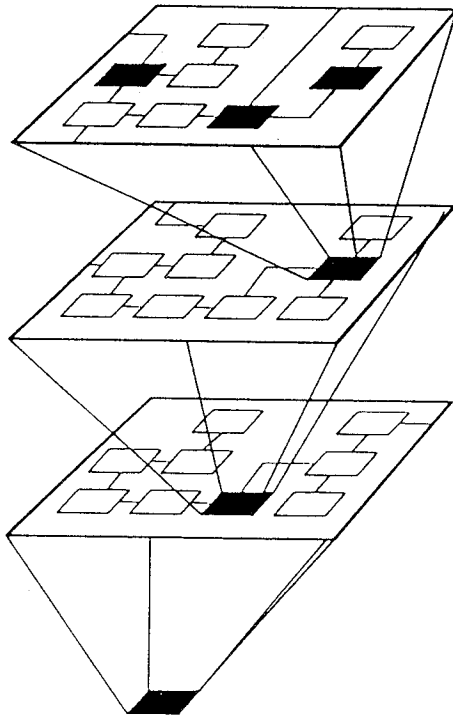

- Replicate functionality to eliminate repetitive design/testing man-hours & reduce errors.
- Store design subsets in a library to allow rapid access and sharing of designs with other jobs.
- Hierarchical top-down or bottom-up design allows easy comprehension and manipulation.

Figure 4

*Intuitive Software for Manufacturing Excellence*

# DESIGN AND ENGINEERING

## Future Growth with Minimum Re-design

- Upgradable.
- Expandable.

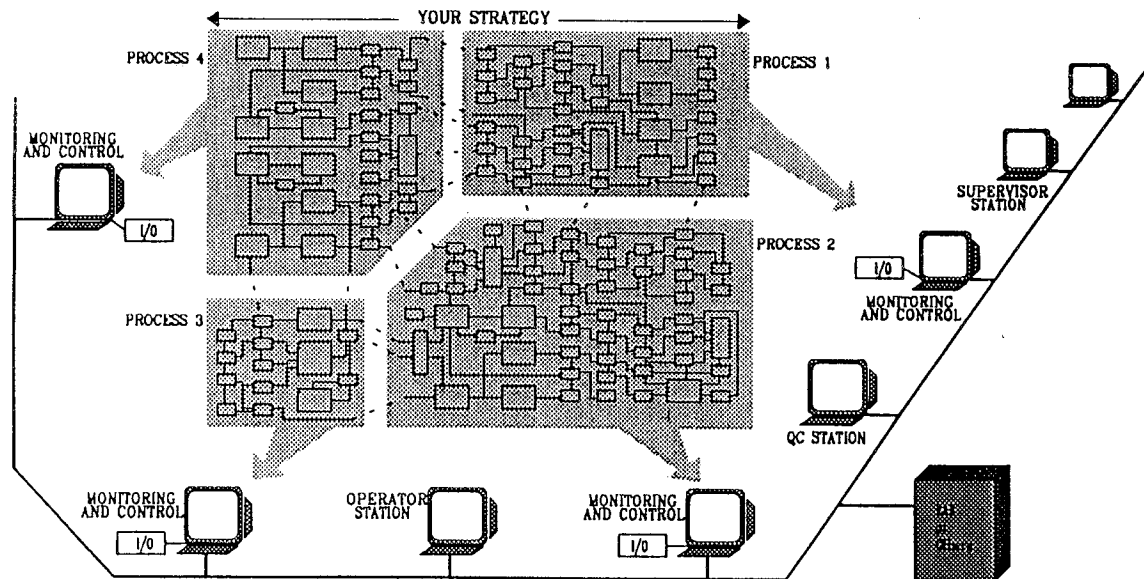

V-22





Figure 5

*Intuitive Software for Manufacturing Excellence*

# CREATIVITY AND INNOVATION

## Non-proprietary Hardware

Apply methods & techniques from other industries.

