

**N93-29706**

**NEXT GENERATION OPTICAL INSTRUMENTS AND SPACE EXPERIMENT BASED ON  
THE LDEF THERMAL CONTROL SURFACES EXPERIMENT (S0069)**

Donald R. Wilkes  
AZ Technology, Inc.  
3322 Memorial Parkway SW, Suite 93  
Huntsville, Alabama 35801  
Phone: 205/880-7481, Fax: 205/880-7483

**SUMMARY**

The Thermal Control Surfaces Experiment (TCSE) was a successful experiment to study the effects of the space environment on thermal control surfaces using in-space optical properties measurements combined with post-flight analyses. The TCSE reflectometer performed well on the LDEF mission demonstrating that a portable compact integrating sphere spectroradiometer can be built that is rugged and space rated. Since the retrieval of the TCSE package from space, several other instruments have evolved from its pioneering technologies. These are the Optical Properties Monitor (OPM), the Laboratory Portable SpectroReflectometer (LPSR), and the Space Portable SpectroReflectometer (SPSR). These instruments and experiment packages are the subject of this paper.

**OPTICAL PROPERTIES MONITOR**

Optical materials (including thermal control surfaces) continue to play increasingly important roles on operational spacecraft and in scientific instruments. The stability of materials used in the space environment continues to be a limiting technology for space missions. This technology is important to all users of space -- NASA, Department of Defense (DoD), Industry, and Universities. The Optical Properties Monitor (OPM) offers a comprehensive space research program for studying the effects of the space environment -- both natural and induced -- on optical, thermal, space power and other materials. The OPM will provide an in-space materials testbed for the optics and thermophysics communities. This common in-space testing facility will become an important part of many materials and space hardware development.

The OPM is being developed under the NASA Office of Aeronautics and Space Technology (OAST) In-Space Technology Experiment Program (INSTEP). The OPM program is currently in Phase B with the PDR scheduled for August, 1992. The Phase A effort selected the optical instruments and environmental monitors to study a wide variety of materials problems in space. It is currently planned for the OPM to fly aboard a reflight of the ESA's EURECA free flier in 1997. EURECA provides an early opportunity for extended space exposure and retrieval of the OPM and its test samples.

## Experiment Objectives

The primary objective of the OPM Experiment is to study the natural and induced effects of the space environment on optical, thermal control, and other materials. Specific objectives are:

- A. *To determine the effects of the space environment on materials* - the effects of the space environment on materials are not well understood. This experiment will provide detailed in-situ optical measurements of these effects to enhance the understanding of the damage mechanisms caused by the synergistic constituents of the space environment. This understanding will enhance the efforts to develop space stable materials.
- B. *To provide flight testing of critical spacecraft and optical materials* - The constituents of the space environment--and certainly the combined environment--cannot be simulated exactly. For this reason, the only sure test of materials--particularly newly developed materials--is to test the material in space, eliminating the uncertainties of simulation testing. The materials to be tested include, but are not limited to those shown in Figure 1.

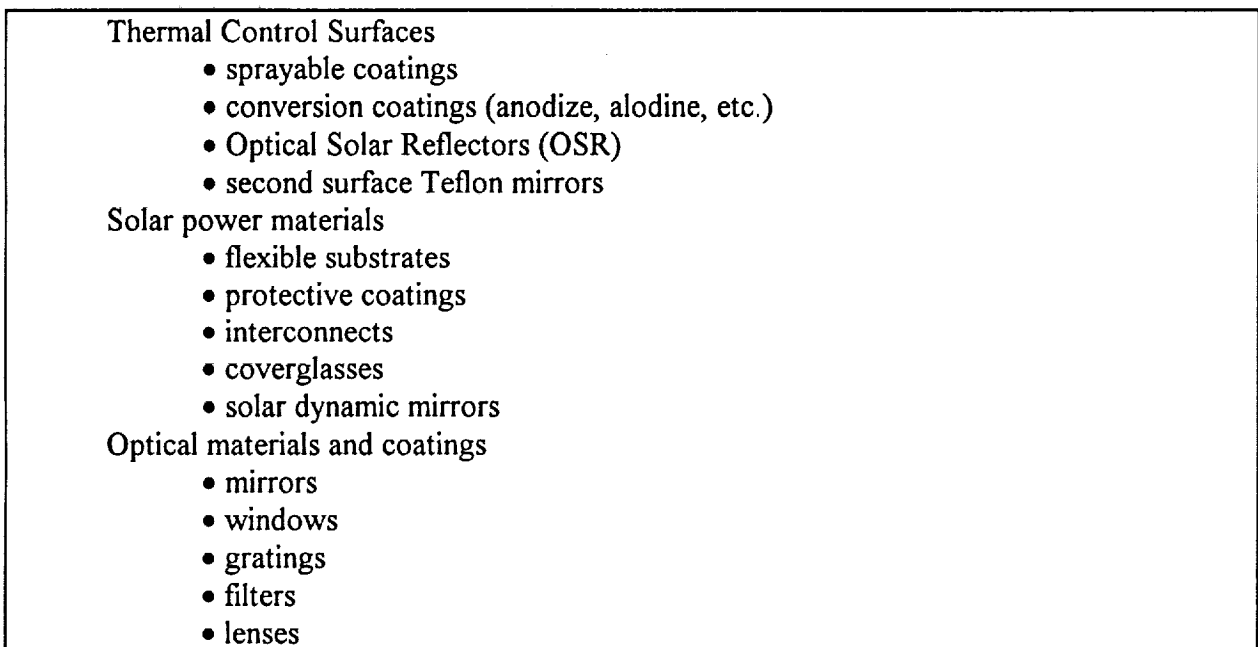

Figure 1. Candidate OPM test materials.

- C. *To validate ground test facilities and techniques* - The current generation of laboratory space simulation facilities is extremely complex and well-designed. However, because of the inability to simulate the space environment exactly, these facilities provide only relative performance of test materials in these limited conditions. Past flight measurements show significant disagreement between flight and laboratory data. An important objective of this experiment is to provide a "calibration" for ground test facilities and techniques with in-space measurements of the same properties measured in ground tests.

- D. *To develop a multifunction, reusable flight instrument for optical studies* - There is a need to test many different materials in space and under different conditions of environment, orientation, temperature, duration, etc. More than one space experiment will be required to satisfy the many requirements. The OPM flight instrument will be designed to be reflown with minimum refurbishment and will allow easy reprogramming to meet varied mission requirements.

### Experiment Description

The Optical Properties Monitor (OPM) is a reusable multifunction in-flight laboratory for in-situ optical studies of materials. Selected materials will be exposed to the space environment and the effects of this exposure measured with on-board optical instruments.

The OPM instruments will measure total hemispherical reflectance, Total Integrated Scatter (TIS) and Vacuum UltraViolet (VUV) reflectance/transmittance. Selected constituents of OPM mission environment are monitored including irradiance, atomic oxygen fluence and molecular contamination. Flight versions of laboratory instruments will be used to perform in-space measurements. A summary of the OPM measurements is shown in Figure 2.

The OPM is a fully integrated package as shown in Figure 3 with the three optical measuring instruments positioned around the periphery of a circular sample carousel. The two contamination monitors (TQCM) and the Atomic Oxygen (AO) monitor are mounted on either side of the exposed portion of the carousel and have the same view of space as the exposed test samples. The Data Acquisition and Control System (DACS) is located inside the OPM enclosure and beneath the carousel.

The test samples are arranged on a circular carousel in four rows. The outside three rows of samples are called "active" samples because they are measured by the OPM optical instruments. The samples on the inner row are designated as "passive" because these samples are not measured in space, but are evaluated in pre- and post-flight testing. The outside row of samples is measured by the VUV spectrometer. The VUV samples must be on the outside to allow for the detector calibration. The second row of samples is measured by the integrating sphere reflectometer. These samples are mounted on calorimeter sample holders for the determination of solar absorptance and total emittance. The third row of samples is measured by the TIS instrument. The integrating sphere, the TIS Coblenz sphere, and one of the two VUV detectors are positioned above the carousel and measure the test samples as the carousel rotates each sample into position.



*Spectral Total Hemispherical Reflectance*

1. Spectral range - 250 to 2500 nm
2. Accuracy -  $\pm 3\%$
3. Repeatability -  $\pm 1\%$
4. Spectral resolution - 5% of wavelength or better

*Total Integrated Scatter*

1. Wavelengths
  - a. 532 nm
  - b. 1064 nm
2. Scatter collection angle - 2.5 to 80 degrees from specular
3. Accuracy -  $\pm 10\%$
4. Repeatability -  $\pm 2\%$
5. Surface rms measurement range - 5-500 Å

*VUV Transmittance/Reflectance*

1. Wavelengths
  - a. 121.6 nm
  - b. 160.6 nm
  - c. 170 nm
  - d. 180 nm
  - e. 200 nm
  - f. 250 nm
2. Accuracy -  $\pm 5\%$
3. Repeatability -  $\pm 5\%$

*Calorimetric Measurements*

1. Total emittance: Accuracy -  $\pm 5\%$
2. Solar absorptance: Accuracy -  $\pm 5\%$

*Environmental Monitors*

1. Molecular contamination
  - a. Temperature-controlled Quartz Crystal Microbalance (TQCM)
  - b. Specially selected witness samples for post flight analysis
2. Atomic oxygen monitor: multiple carbon film sensors
  - a. Sensitivity -  $1 \times 10^{16}$  atoms/cm<sup>2</sup>
  - b. Fluence range -  $1 \times 10^{18}$  to  $5 \times 10^{20}$  atoms/cm<sup>2</sup>
  - c. Fluence range is adjustable by varying carbon film thickness
3. Irradiance monitors
  - a. Direct solar
  - b. Earth albedo
  - c. Earth IR emittance
  - d. Measurement accuracy - 5%

Figure 2. OPM measurement summary.

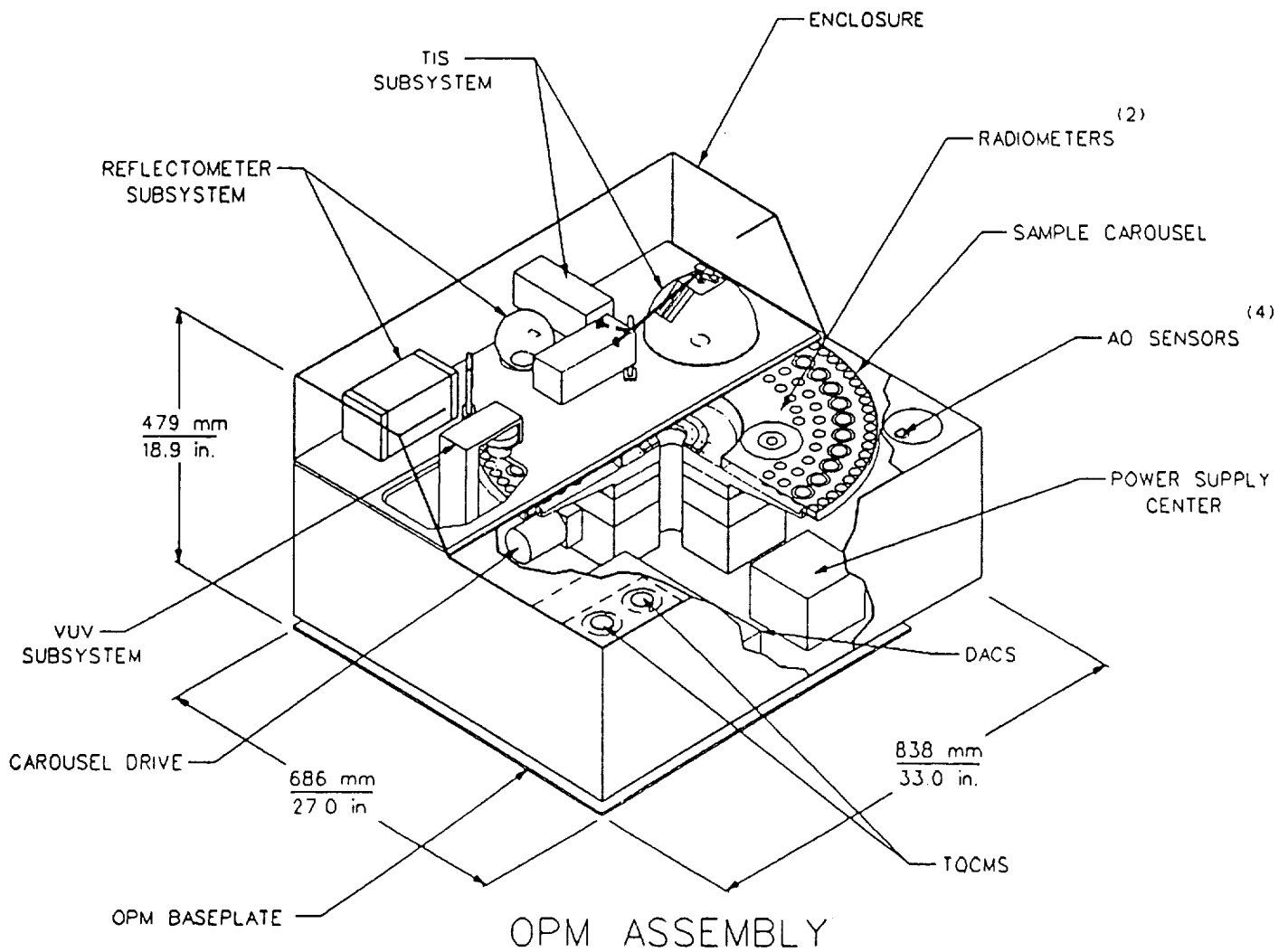

Figure 3. OPM instrument assembly.

C-4

Only half of the carousel and the test samples are exposed at one time. The samples that will be exposed during the operational orbit are not exposed during ground processing, launch, orbital transfer maneuvers (OTM), and deorbit operations. A second set of samples is exposed during these periods and will be measured before and after OTM to the operational orbit and again before and after OTM to the parking orbit for retrieval by the Shuttle.

## LABORATORY PORTABLE SPECTROREFLECTOMETER (LPSR)

The Laboratory Portable SpectroReflectometer (LPSR) is a unique integrating sphere instrument for easily and quickly measuring total hemispherical reflectance of almost any surface over the solar region of the spectrum (250-2500nm). The instrument incorporates innovative optical, mechanical, and electronic designs to provide state-of-the-art performance in a compact and portable configuration. The LPSR has been designed for use both in the field for measuring the extended surfaces of operational or developmental hardware and for use in the laboratory on test specimens of varying sizes. The LPSR provides highly precise and accurate data on all types of surfaces without the errors present in some less sophisticated designs.

The LPSR user interface provides one button operation for standard measurement scans or selectable options for special measurements. A manual operation mode is also provided. The menu-driven data display leads the user through the setup and operation of the LPSR including the display of the measurement data. Automatic integration of the reflectance data is performed to calculate and display solar absorptance. Internal non-volatile storage of up to 40 full measurement scans is provided for field measurements.

Interface and database software is provided for a host PC compatible computer for retrieving, archiving, and data display of LPSR data. Remote operation is also provided by the host software with full control of all LPSR functions. The LPSR/PC host connection is made through a standard PC serial interface.

### LPSR-200 Specifications

The AZ Technology LPSR model 200 is a commercially available instrument to perform total hemispherical spectral reflectance measurements on almost any shape, size or type surface. The measurement is of the "absolute" type, provided by the integrating sphere measurement technique.

The basic measurement performance specifications are:

- Reflectance repeatability:  $\pm 1\%$
- Wavelength range: 250 to 2500 nm in 100 steps
- Wavelength repeatability:  $\pm 1\%$



- Spectral resolution: 5% of wavelength or better
- Scan Time:  $\leq 120$  seconds
- Sample size: 0.5 in. or larger
- Size/weight
  - Measurement head: 8 3/8" x 10 1/8" x 12 3/8"; 15 pounds
  - Power supply/carry case: 16" x 20" x 14"; 25 pounds

The LPSR optical design shown in Figure 4 is similar to laboratory system and to the TCSE reflectometer. Figures 5 and 6 are photographs of the LPSR. The repeatability of the LPSR is shown in Figure 7. Figures 8 to 10 demonstrate the measurement comparison of the LPSR and the computer controlled Beckman DK-2A/Gier Dunkle 8 inch integrating sphere reflectometer at the Marshall Space Flight Center.

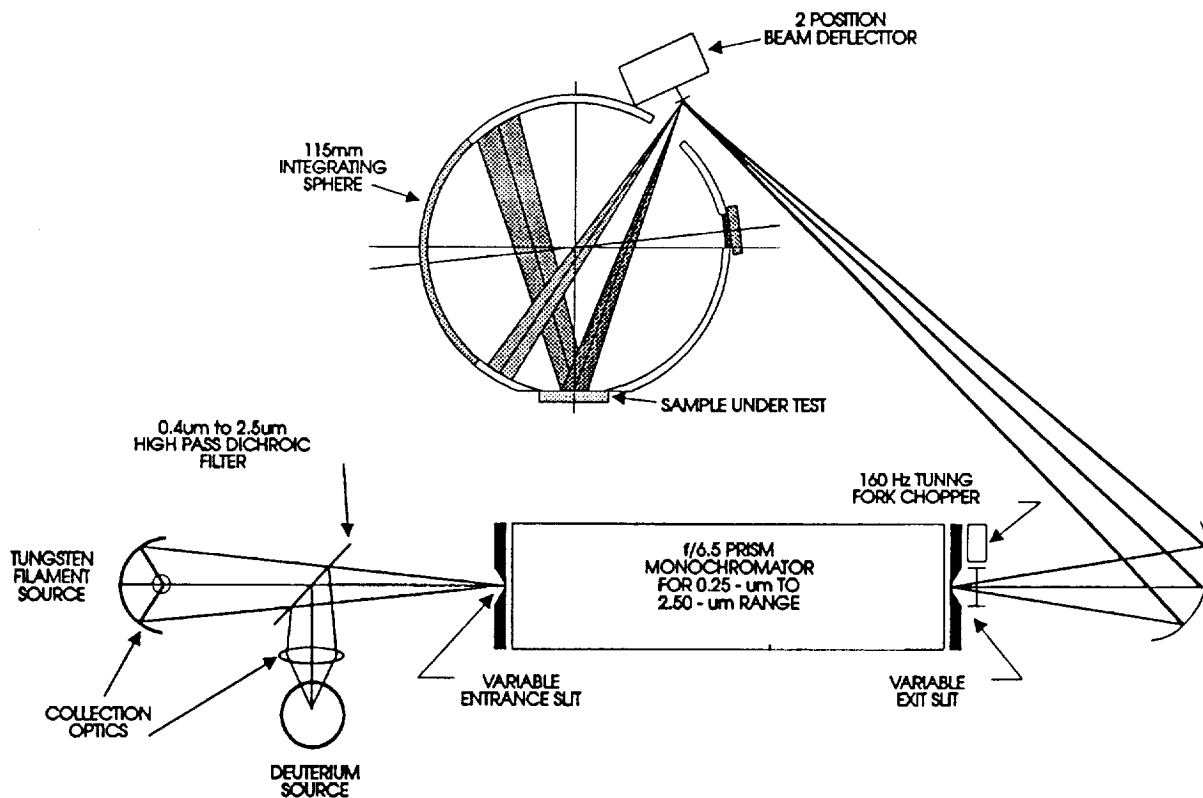

Figure 4. Optical schematic.

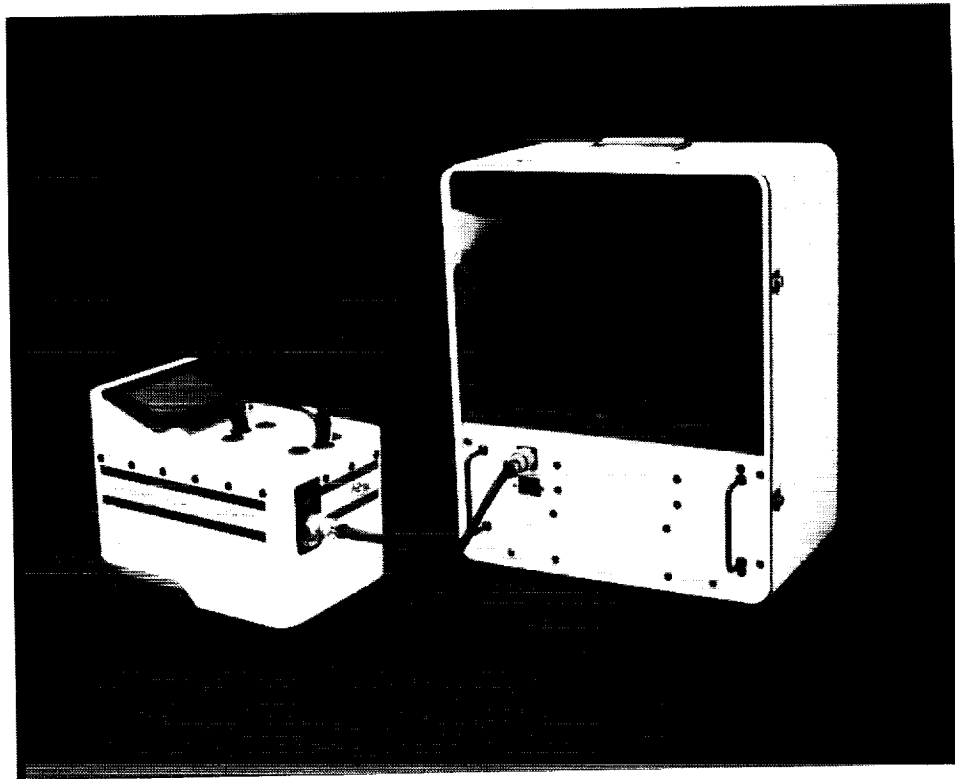

Figure 5. LPSR measurement head and carrying case.

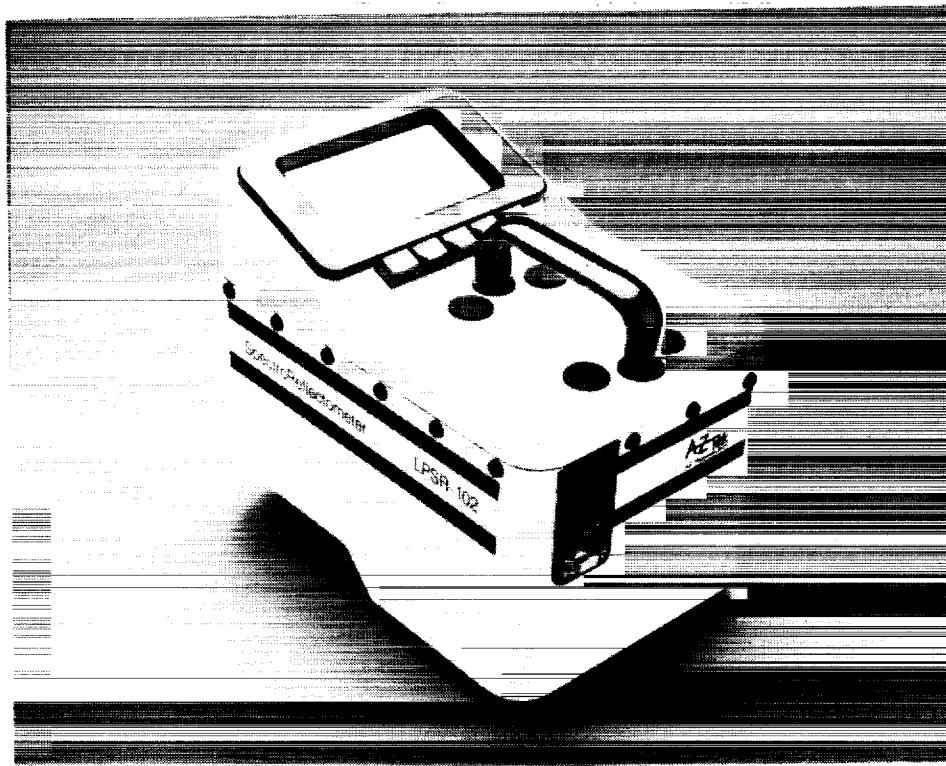

Figure 6. LPSR measurement head.



LPSR repeatability is demonstrated by this plot of three separate measurements of S13G/LO white paint.

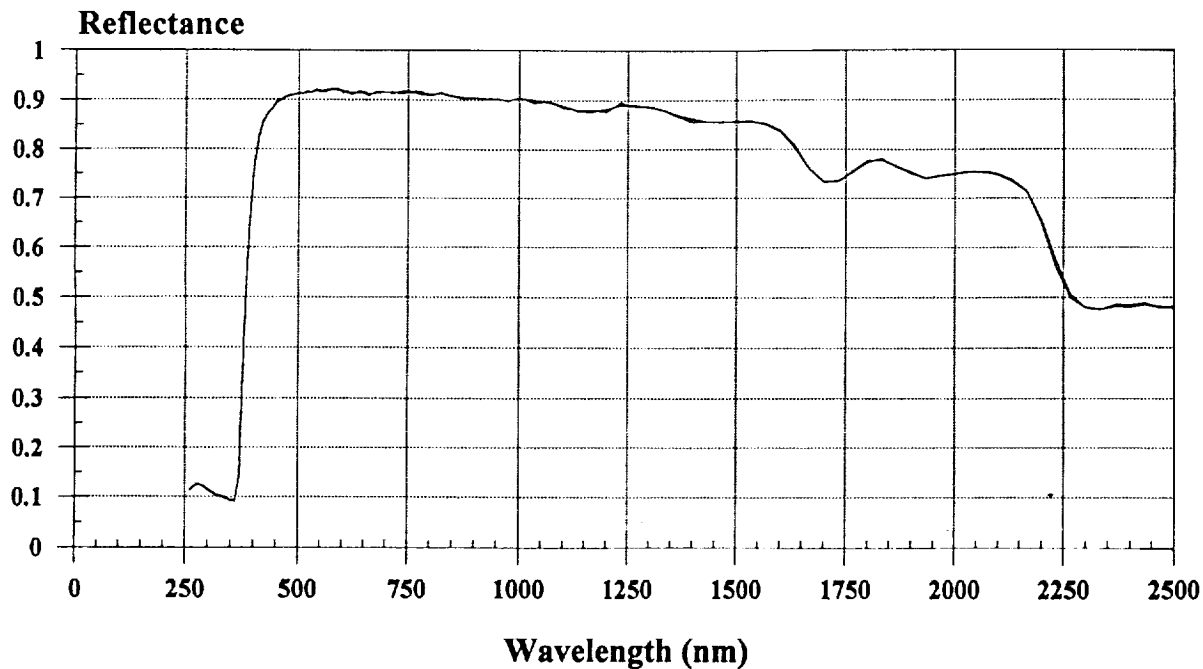

Figure 7. LPSR repeatability.

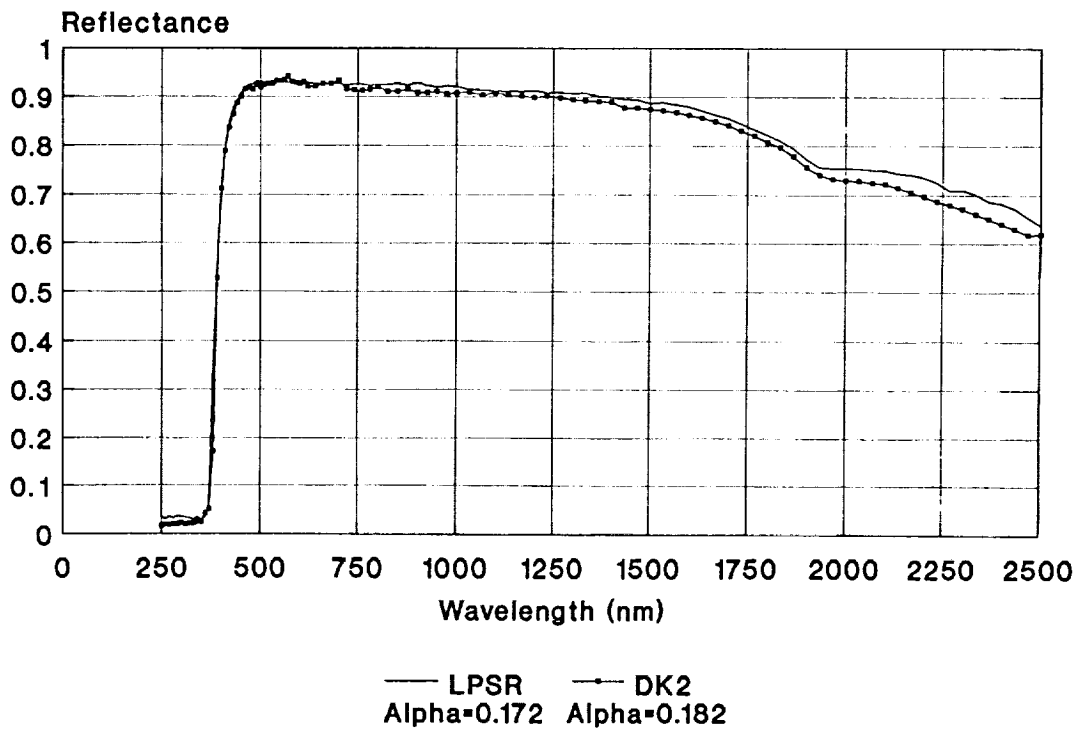

Figure 8. LPSR/DK2 reflectance data comparison - Z93 white paint.

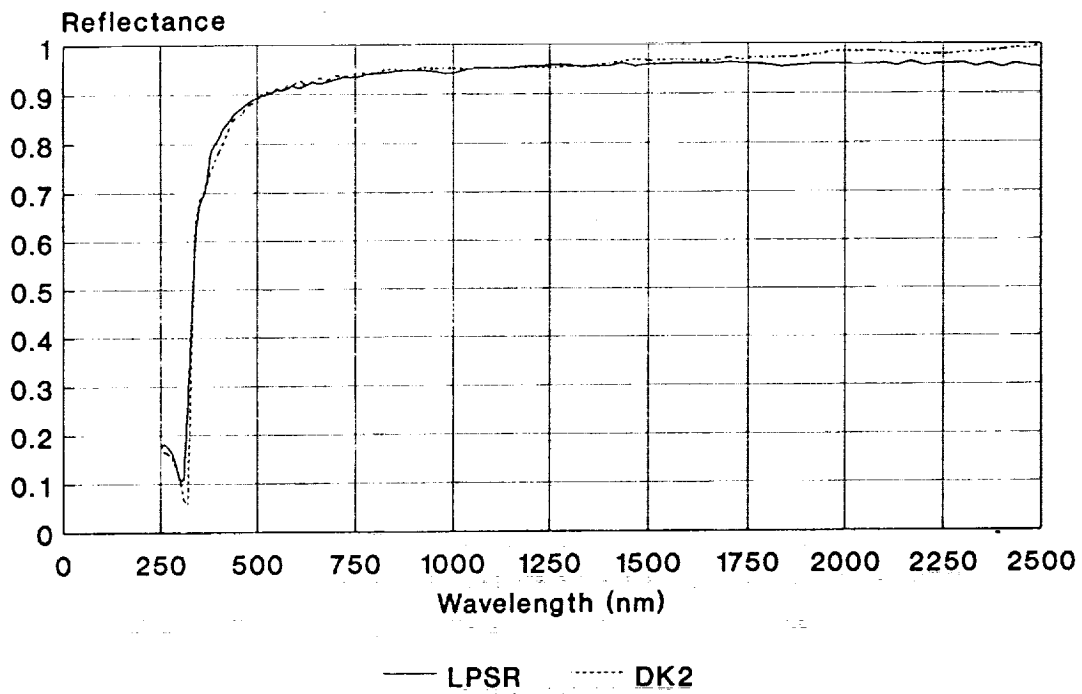

Figure 9. LPSR/DK2 reflectance data comparison - silver teflon.

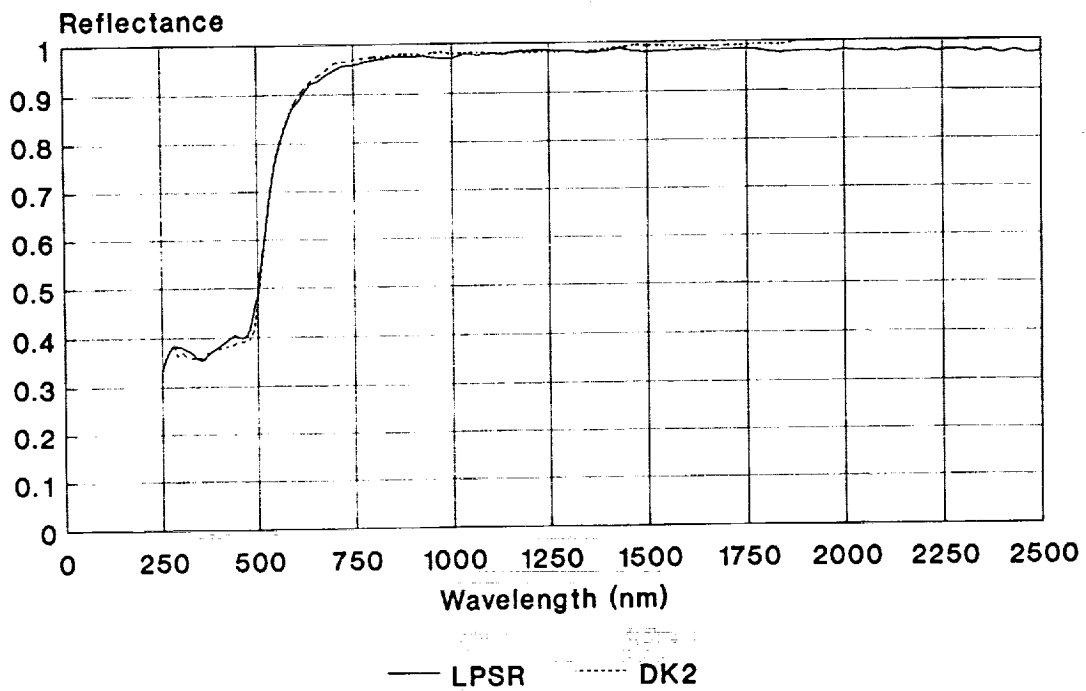

Figure 10. LPSR/DK2 reflectance data comparison - gold mirror.

## SPACE PORTABLE SPECTROREFLECTOMETER (SPSR)

The condition of external surfaces is critically important to the success of long duration missions. These surfaces are susceptible to degradation by the natural and spacecraft induced environments. Therefore, there is a need to measure the properties of spacecraft surfaces to verify surface conditions and determine when and if maintenance, repair or replacement are required.

To address this need the Space Portable SpectroReflectometer (SPSR) is being designed to measure the total hemispherical reflectance of practically any external surface on a spacecraft while it is in orbit. The SPSR will become a standard utility instrument for routine long term space operations. Two configurations of SPSR are being developed including a hand-held unit much like the laboratory instrument (LPSR), and a remotely operated instrument which is operated using the Remote Manipulator System (RMS) aboard the Space Shuttle or Space Station Freedom. The SPSR concepts are illustrated in Figures 11 and 12.

The SPSR is being developed under the Small Business Innovative Research (SBIR) program and is currently in Phase II. The SPSR electro-optical subsystem is based on the TCSE reflectometer and incorporates the same improvements and performance as the LPSR. In this phase, the program will verify: (1) measurement performance on typical spacecraft surfaces with variations in size, shape, and material, (2) operational capability under simulated mission conditions, and (3) viability of the SPSR design for in-space operation. Prototypes of both configurations of the SPSR will be built and tested.

The handheld and remotely operated versions of the SPSR incorporate the same electro-optical system as the LPSR. The handheld design provides a larger handle and switches to accommodate the EVA suit glove. Also included are target illumination lamps and contact sensors to aid an astronaut in positioning the SPSR on a surface for measurement.

The remotely operated version (shown in Figure 13) also incorporates the target illumination lamps and contact sensors. In addition, other positioning aids include a laser range finder and a video camera.

The current SPSR effort will be completed in mid 1993. A flight opportunity is needed to flight test the SPSR as a utility instrument for space operations. Potential applications include Space Station Freedom, the maintenance mission for the Hubble Space Telescope, other space system maintenance missions, routine space vehicle commissioning, and the Space Exploration Initiative.

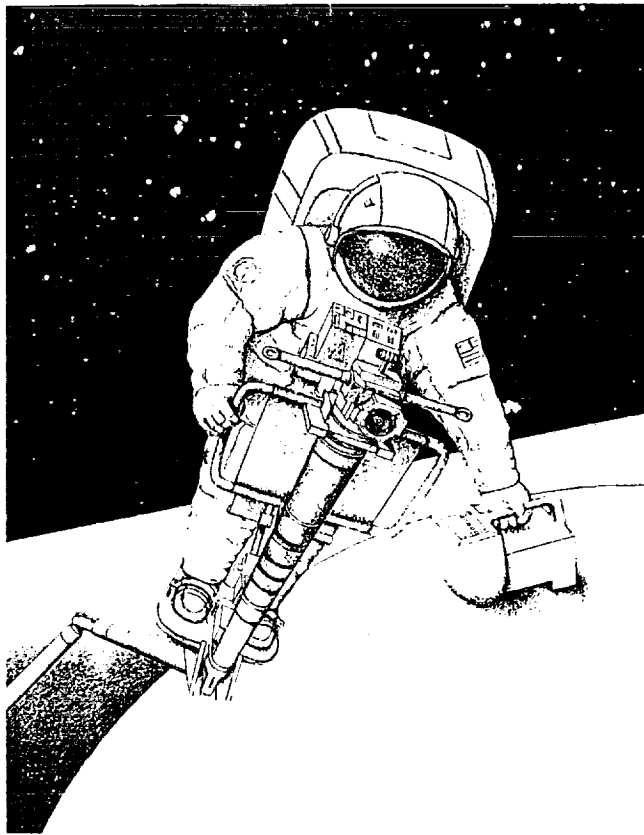

Figure 11. Concept for the handheld SPSR.

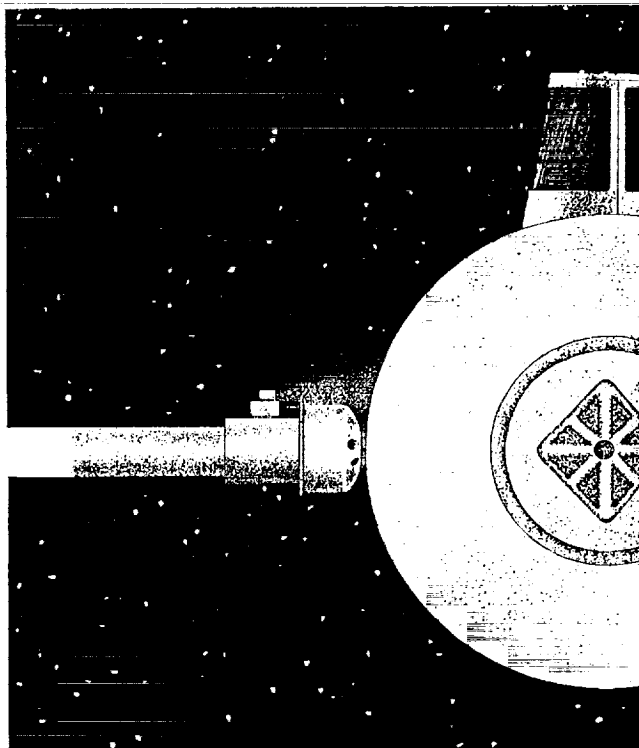

Figure 12. Concept for the remotely operated SPSR.

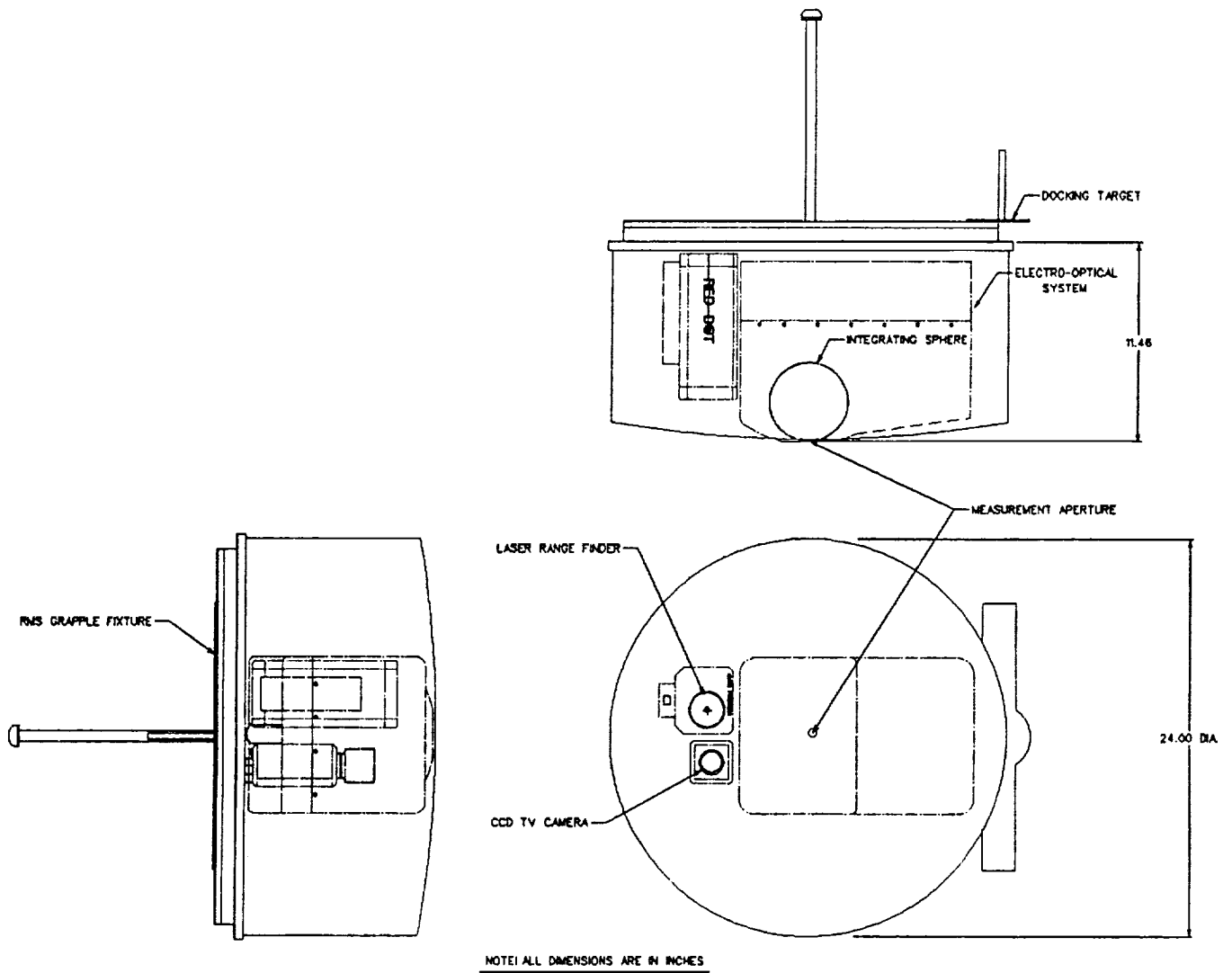

Figure 13. Remotely operated SPSR configuration.

