

* * *
Luncheon Address

N 93 - 80429

* * *



7-35

COMPOSITES: A VIABLE OPTION

BR 798021

John E. McCarty

While it sounded great to be asked to talk about composites, I found it difficult to select subject areas that would be of real interest. My choice is based on saying some things about where the maturity of the composite aircraft structures is today and what that means in terms of future criteria for application. This focus was the basis for my title selection. The other issue that will be addressed was requested by NASA and focuses on composites structures cost. This fits well with the state-of-the-art interpretations I will discuss first, since the cost issue must be viewed from both the current status and future points of view. The difficulty in presenting something in these areas is not in the subjects themselves but in trying to present a real world viewpoint to an audience of composite experts. So, with recognition of the expertise of the audience, I hope you will see something in this presentation about how to view composite aircraft structure.

Introduction

- NASA - introduction and vision
- Composite aircraft - option validation
- Aircraft structure
- Composite cost considerations
- Composite potential - commercial

As noted, my initiation into the composite field and my association with NASA began at basically the same time. My first trip to NASA Langley was to take over contract management of Boeing's first composite contract with NASA that Reid June [redacted] was managing. Boeing management had decided that Reid was to help out on SST and I was to replace him on the NASA contract. My flight to NASA was one of those that I am sure all of you who have traveled a lot have experienced. I arrived at Newport News at 4:00 o'clock in the morning with the scheduled review on the contract at 8:00 o'clock. As the picture shows, about a minute after Reid introduced me as the new contract manager and the lights were dimmed for the presentation, I caught up on my missed night's sleep. There were and are those at NASA that have taken many opportunities to remind me of this, their initial impression of me.

NASA - Introduction

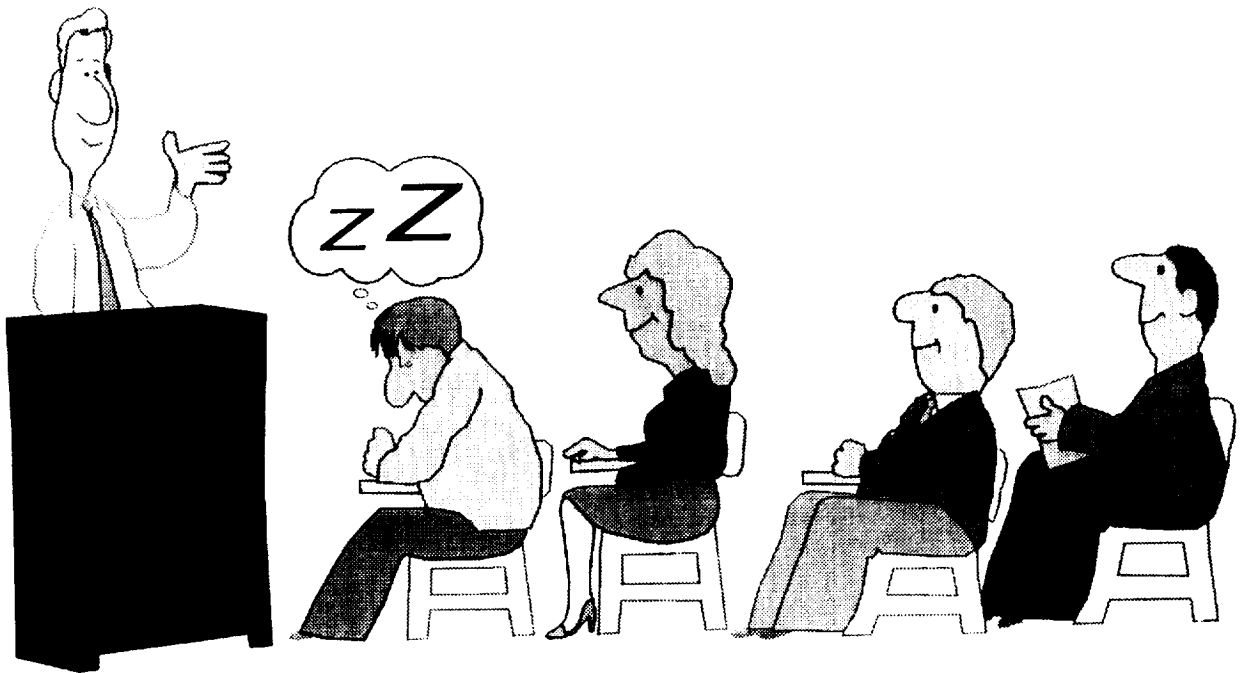

I feel it is only fair play that I give my friends at NASA the similar type of reminder they have often given me on my introduction to them. This chart is to remind them about the NASA/ACEE program initial bid phase that was won by Lockheed. As all company managements will, Boeing's wanted to know why they lost the contract bid. Since Reid and I were the ones preparing the bid, we of course went with our bosses to NASA to find out what we did wrong. There were several reasons expressed by NASA for Boeing's loss. A simple one was that Lockheed just had a better overall proposal. But one point that NASA focused on and that they said was one of the keys for our loss was our use of the 737 vertical tail component, since the 737 represented an aircraft with little future sales potential. My only response to NASA now is to say I hope your vision into the future is better now.

NASA: Vision

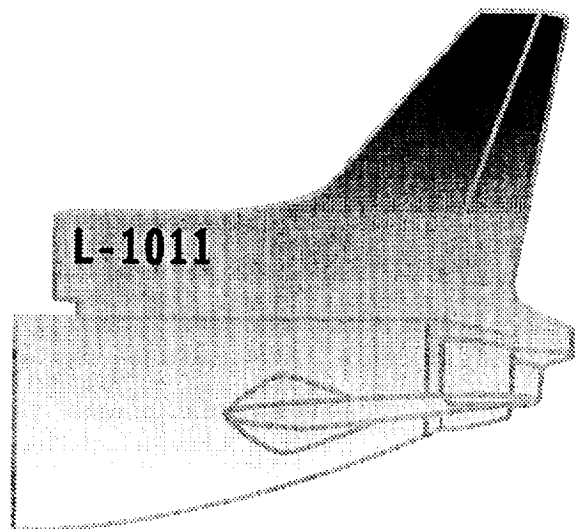
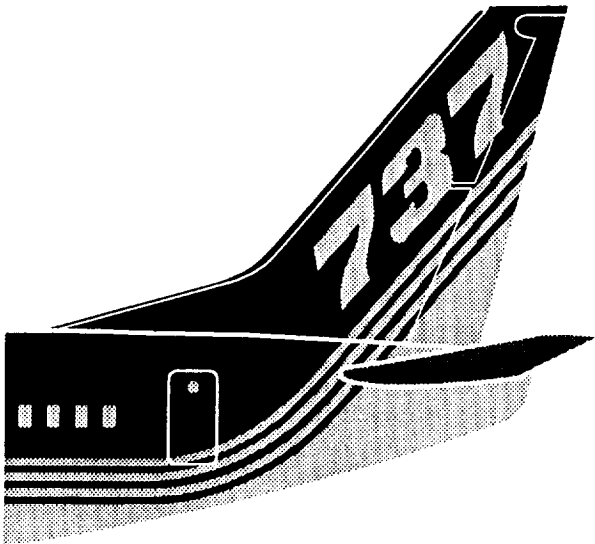

With this discussion of the past, between those I hope I can still call friends, let's take a look at the status of composites technology from the point of view of the presentation title. I selected the title because I had a boss that said, "When a material is considered during the preliminary design and product development phase of an aircraft program on an equal basis with other material options, it has become a viable option." I believe this is the status of composite materials today. What does this mean in terms of the selection and potential usage on future commercial transport aircraft. To understand this you need to understand the evolutionary changes that take place in commercial aircraft and the role the service usage plays in the design approaches taken. The selection of a viable material also means that it is not selected because it is the fad or to start the technology learning process. The scale on the chart emphasizes the equal weighing of all the structure material options on their merits. This means no bias criteria for or against a material systems selection. I am sure all the members of the audience that have been promoters of composites have experienced the imposition of special criteria on composites by those not wanting to change from metals. Finally, the things that are needed to make the change are a need to improve the product, an inhouse champion at the appropriate management level, and a need in the marketplace for a new aircraft in a competitive environment. The key here again is the acceptance of composites on an equal basis and weighed on a scale with the same acceptance parameters.

Composite Structures Selection

- Commercial aircraft design environment
 - Evolution
 - Service time

- Selection from the options
 - Criteria bias
 - Weighing of options

- Making the change
 - Need
 - Champion
 - Market

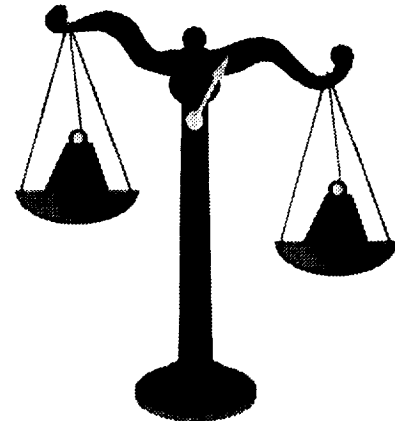

This chart simply displays that we now have a significant history of composite applications in military, civil, and commercial aircraft. This history also suggests that with this background the technology base is such that the material is truly a viable option for future designs.

Composite Structure Applications

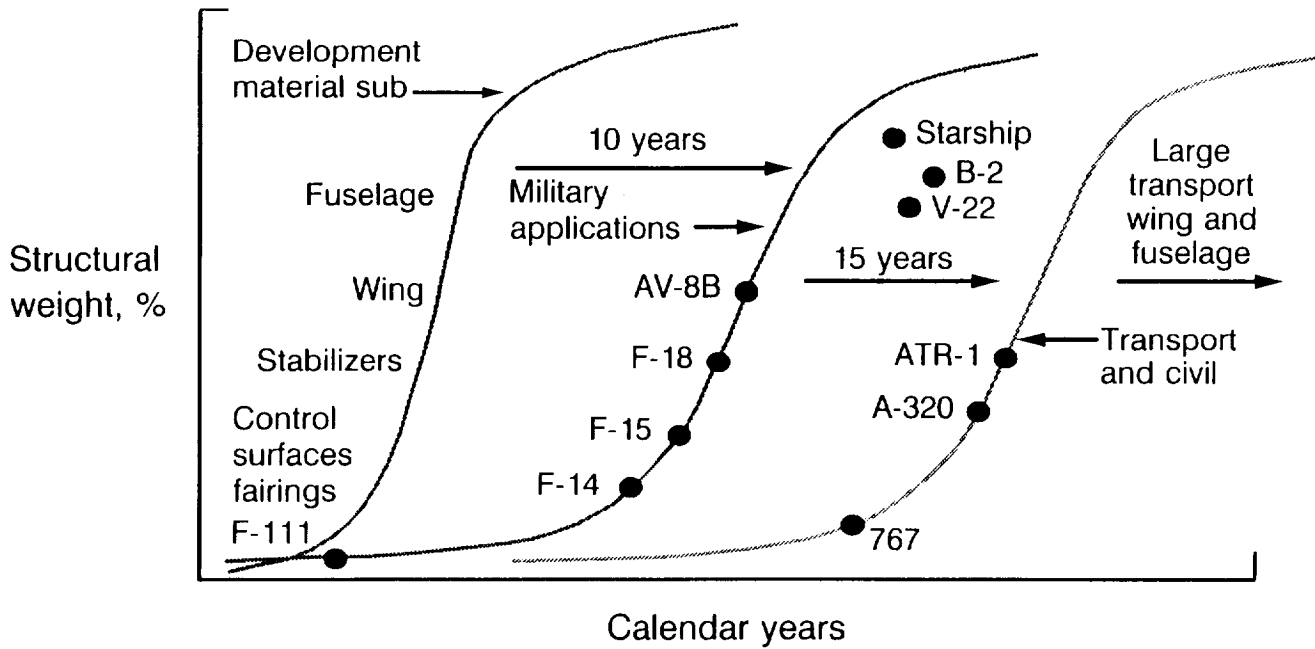

One of the questions often asked by management when stepping up to the selection of a new material system is “Do we know how to certify it?” This list of civil and commercial aircraft components and aircraft that have been certified should emphatically answer that question in a positive manner. The certification process has been experienced by all the large commercial airframe manufacturers. The FAA now has the experience to deal with composite structural systems and to feel confident in their certification process. This certification question can no longer be a basis for not selecting composites on an equal basis with metals.

Certified - Applications

Key Primary Structure

- Transport category
 - Aerospatiale/Aeritalia outboard wing 11/15/89
 - Airbus A300-600 vertical stabilizer 3/28/88
 - Airbus A310-300 vertical stabilizer 6/10/87
 - Airbus A320 vertical and horizontal stabilizer 12/15/88
 - DC-10 vertical stabilizer 6/03/86
 - Boeing 737 horizontal stabilizer 11/14/84

- Normal (civil) category
 - Windecker Eagle entire aircraft 12/18/69
 - Beech 2000 (Starship) entire aircraft 6/14/88
 - Piaggio P-180 empennage, canard, and aft fuselage 5/07/90

I show this picture of the Beech Starship since it is certified and in production. It represents what can certainly be called an all composite aircraft. The issues of fuel in the wing and a fuselage pressurized shell were both accounted for in its certification process. With the production underway it will be the aircraft by which all future composite civil aircraft will be measured. My salute to Beech Aircraft Company for the development and certification of the Starship.

Starship

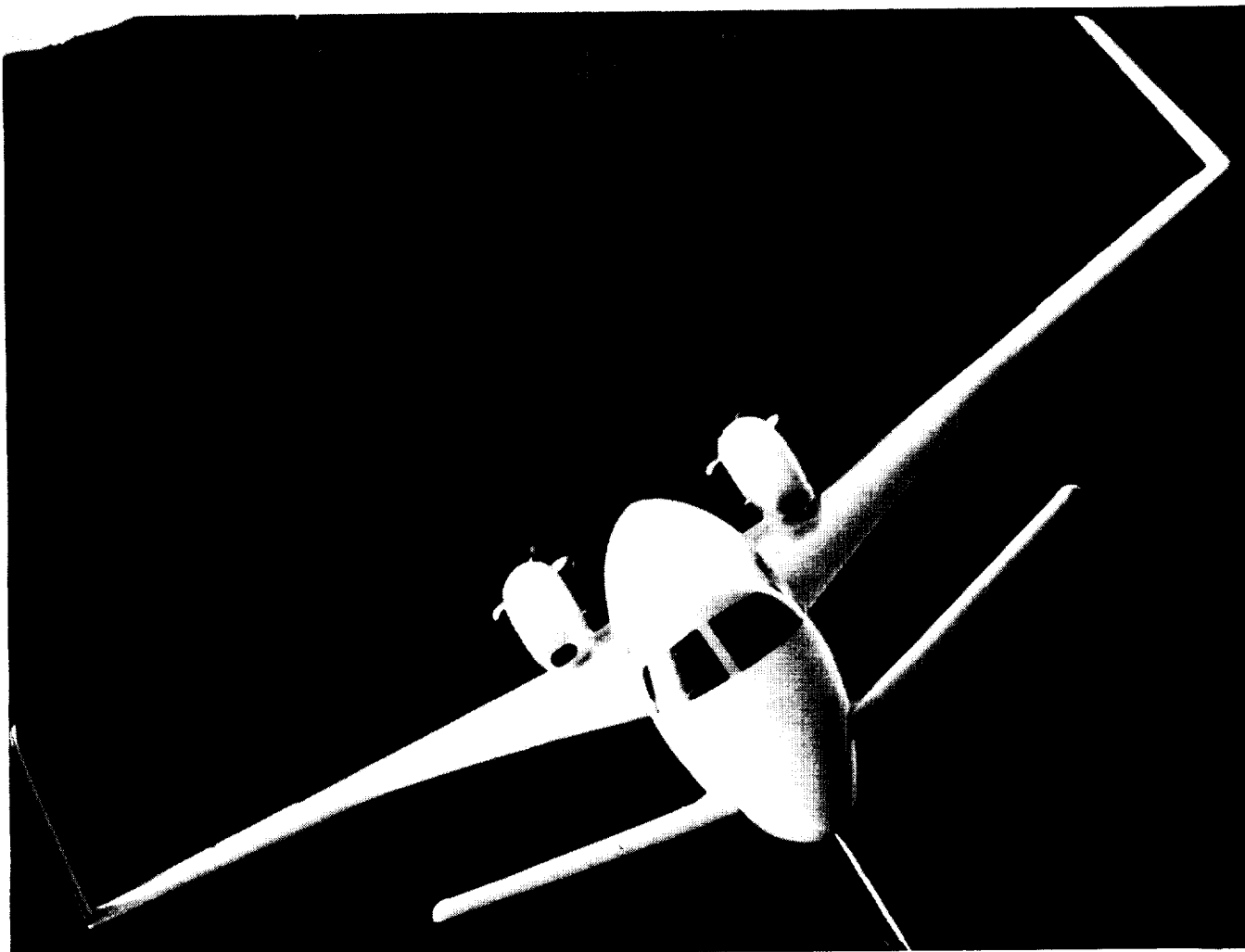

ORIGINAL PAGE
BLACK AND WHITE PHOTOGRAPH

Almost all my general or overview presentations have shown this picture, since I believe it clearly dramatizes the size considerations that must be part of the stepping up to commitment of composites to commercial aircraft. The risk from a manufacturing and cost point of view is directly related to this size effect. The structural mechanics are not different between fighters and commercial transports, but the manufacturing differences are as great as the differences shown in this picture. Those who have worked on large aircraft production readily recognize this size effect.

Aircraft Size Considerations

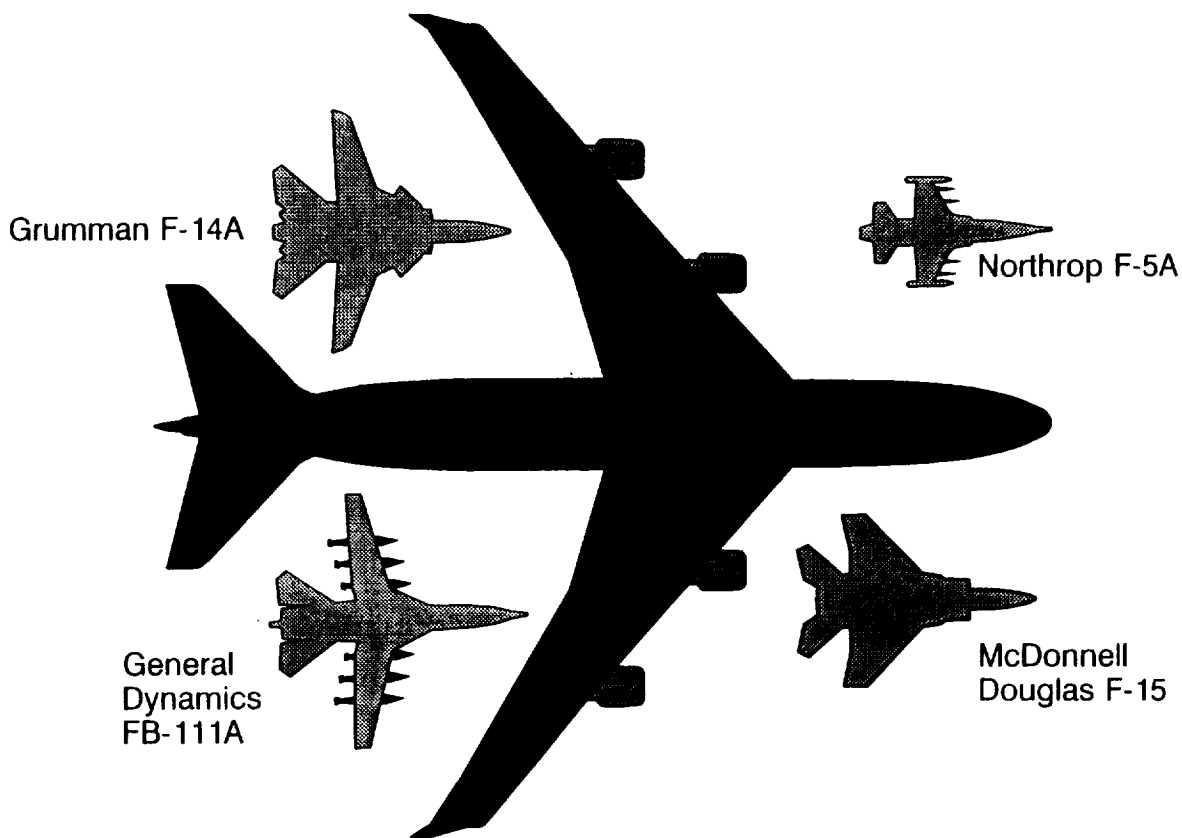

This is just another way of expressing the effect of size. It simply says that as expected there are major structural differences in the 767 rudder and the AV-8A wing. These differences are simply reflected in their weight differences, even though their dimensions are very similar. The difference in their design requirements obviously makes significant difference in their design details and the manufacturing cost of those details.

Application Considerations

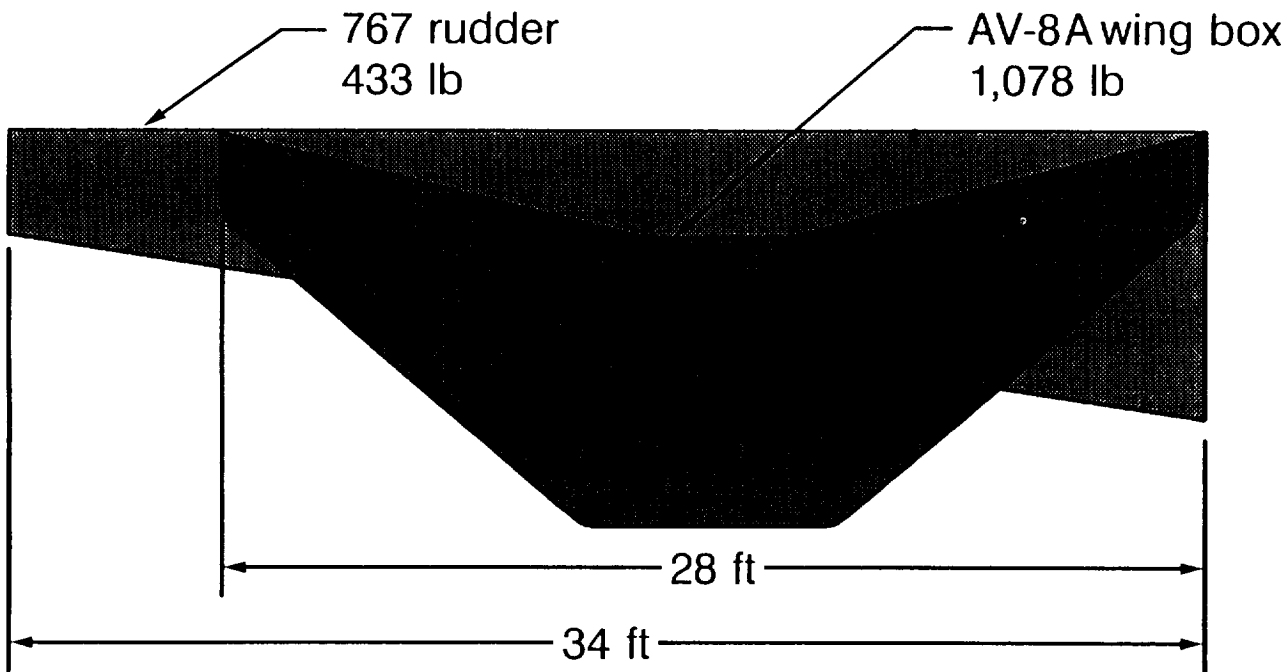

These two pictures show that the technology for design of composite components covers not only the fighter size airframes but now covers wing spans that are similar to large commercial aircraft. Therefore, to continue the argument that industry does not have the background in large airframes is no longer a valid view of composite airframe structures. This preceding discussion states simply and clearly that it is now time and the industry is ready to complete the technology steps to the large commercial aircraft of composites, a viable material option.

B-2 Bomber

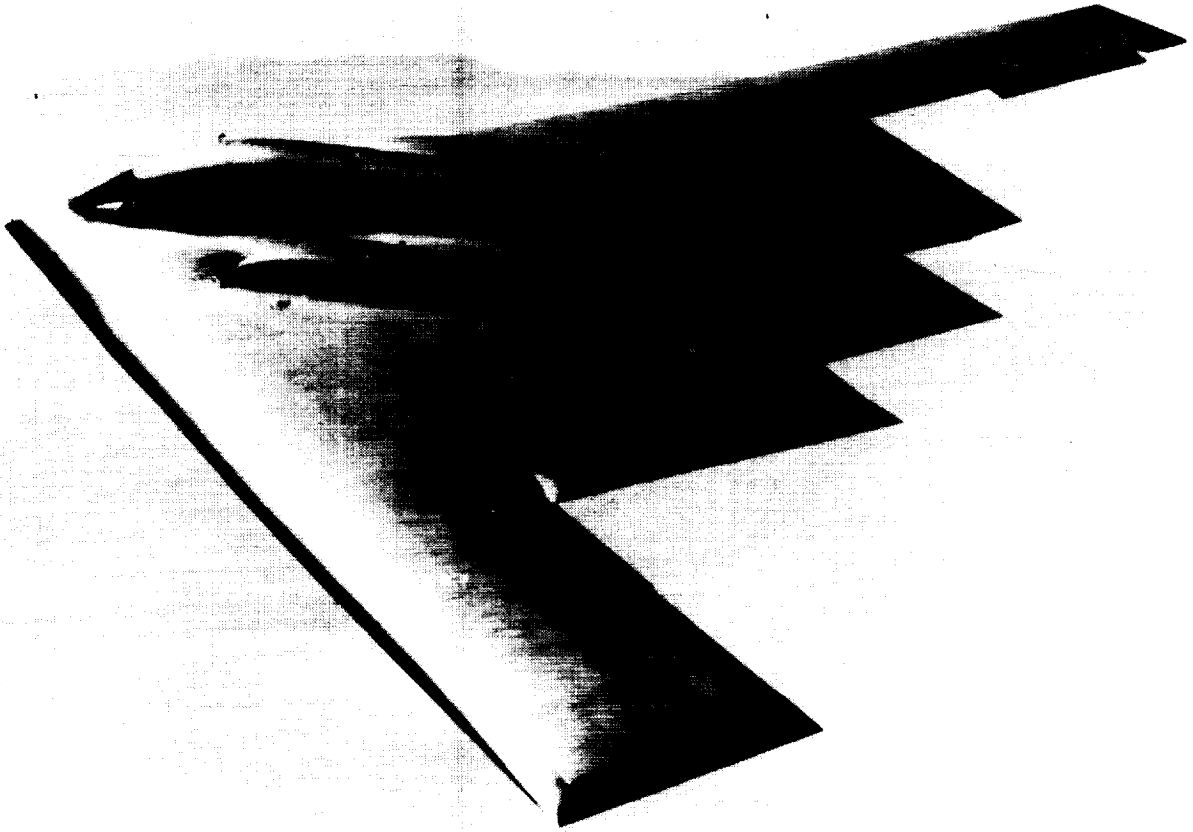

Transport Size Transition to Composites

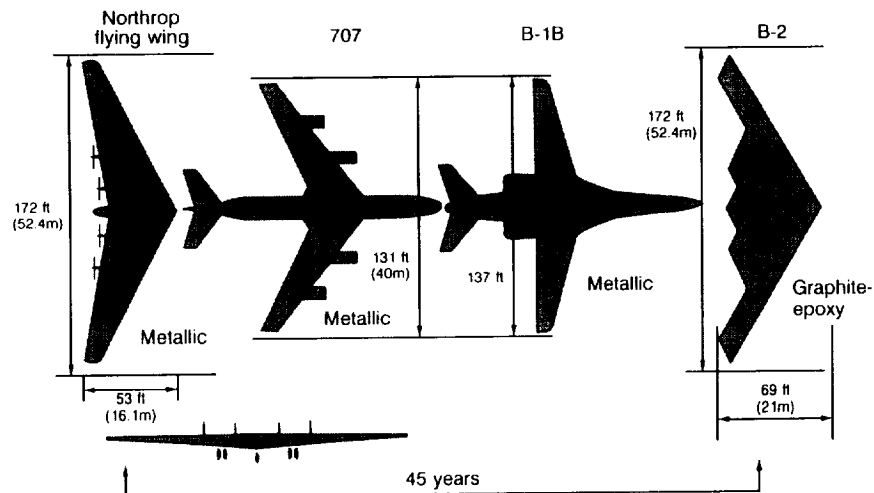

The next step in assessing if the large commercial aircraft industry should step up to the design and development of the final major components of wing and fuselage lies with the need for new aircraft. The cycle for new commercial aircraft (those not government subsidized) continues to grow in time. The past time cycle was 7 to 10 years and has more recently expanded to 12 to 15 years. This chart simply shows that even with the new aircraft coming along now, there should be a market for another new round of aircraft in the period 2005 to 2015. Therefore, the final developments needed for cost risk reduction in producing a commercial aircraft should be addressed now. The current NASA ACT program, which this meeting is about, has the right timing to aid the US commercial airframe companies to compete with the rest of the world.

Market Forecast - Share by Airplane Size

Units and Dollars
Total Market 1992 to 2005

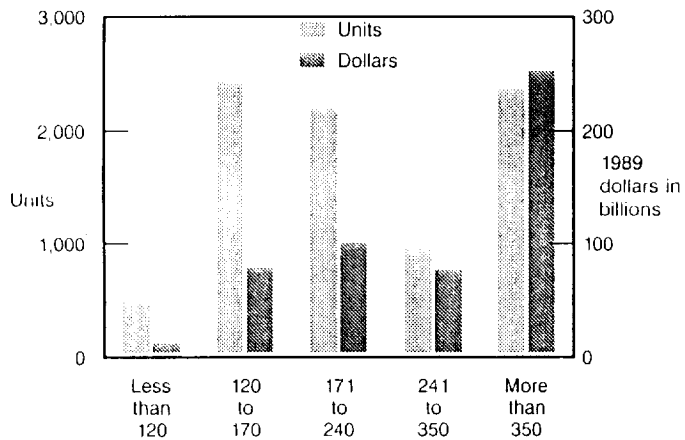

Seats

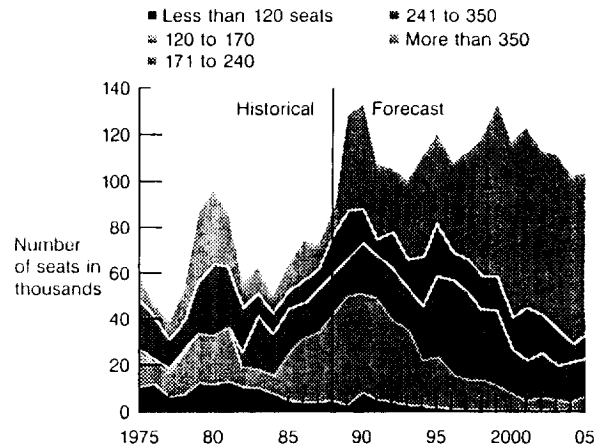

This chart shows that the cost of aircraft has followed a fairly well defined pattern and that to compete in the future the cost of the aircraft must meet or beat this established pattern. No company will risk the initiation of a new aircraft within its own funding capabilities if it cannot be sure of its ability to not only project the cost but to control the manufacturing cost after commitment to production. This scenario leads directly to the reason that cost of composite structures is now the issue, not structural technology. The evaluation and design of the structure will require the continued development of better composite structural analysis tools. However, the technology to manufacture that structure in an economical manner is the key to the risk acceptance for the manufacturers. The measuring stick for assessing the success of development of the manufacturing processes and tools will be the comparison of the cost of large composite structures against the 50 to 60 year base for metals structures, a tough comparison for composite structures.

Aircraft Cost Trends

Aircraft Costs 1988 to 1989

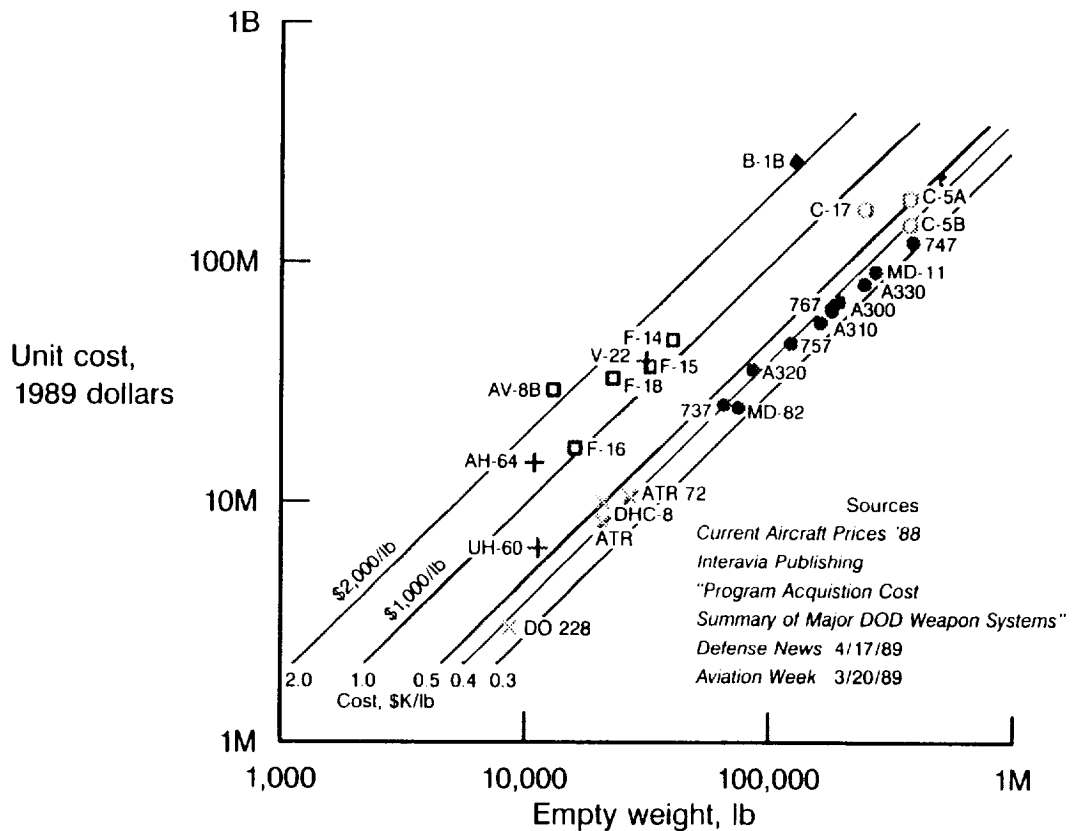

This chart shows what we must consider in a plan to assess how to meet that tough comparison with the manufacturing experience base of metal structures and has been seen by many of you at other presentations and conferences. I show it here because I believe in what it tells us so strongly. Our ability as structural engineers and manufacturing engineers to save cost and weight decreases with program time. As the program progresses to each following phase, opportunities for cost and weight savings are lost. The first person to have the largest chance at cost and weight savings is the configuration engineer as he draws the first three view drawings and establishes the aircraft arrangement. From the aircraft arrangement comes the structural arrangement against which various material systems and structural concepts are assessed. There is complete freedom for structural considerations in this stage of design development within the constraints of the airplane mission. As can be expected, each following phase is constrained by decisions made in the preceding phase. This scenario clearly suggests that cost and weight be a significant consideration at the initial step as well as performance or mission requirements.

Program Schedule and Cost Savings

Decreasing Opportunities for Cost Savings

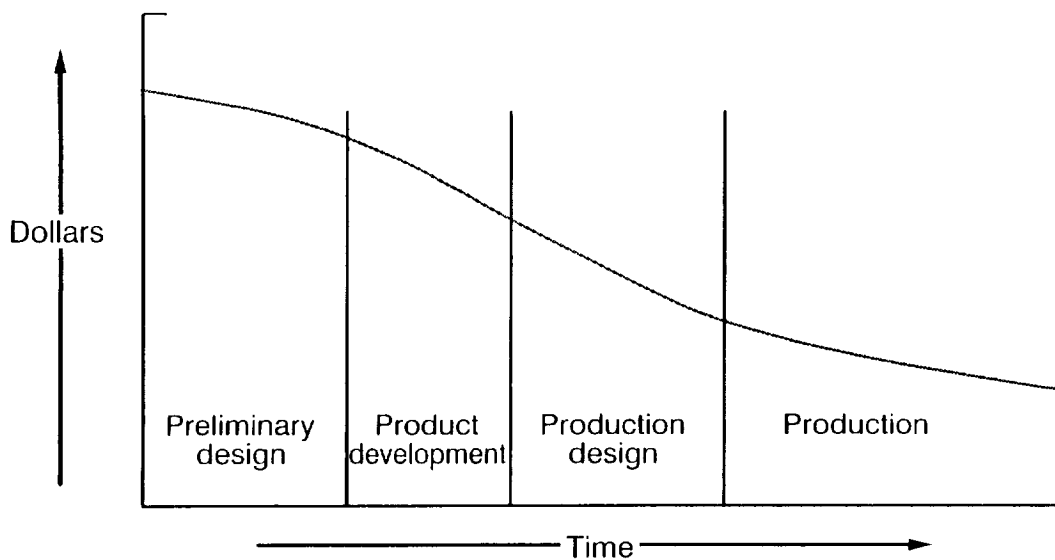

This chart shows how the idea of the value of weight savings varies with the same development cycle. During the initial phase it is not a very large number since the optimism is that the design will easily meet weight projections and performance requirements. When the cycle reaches the production drawing release, the real weight numbers begin to appear and panic sets in to meet weight targets and performance specifications. This raises the value of weight savings, and this is when all the awards for weight savings are given. These two charts together suggest that the awards in the production drawing release phase may add to the weight savings needed to solve the overweight problem when recognized. However, since the savings are evaluated on a dollars/pound basis, this is a cost issue as well as a weight issue and perhaps the award for both cost and weight saving should be issued in the preliminary design phases as well. Simply stated, we may be giving awards at the wrong time.

Program Schedule and Value of Weight Savings

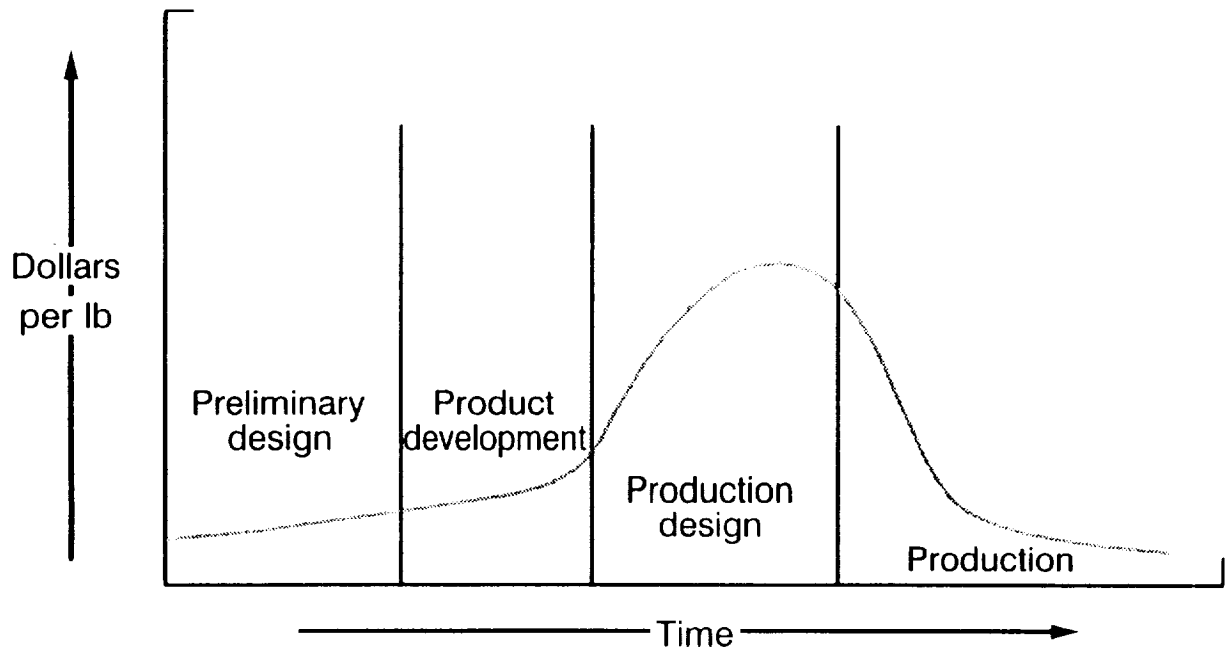

This chart (upper section) is one that I have used many times to focus on the issues of static strength and damage tolerance of composites. The lower half of the chart addresses the cost, considering both the manufacturing costs and the in service maintenance cost. The bottom four items are of direct interest to this presentation. The material cost is one of the issues that is being discussed at this conference. The other is the so called "designed-in cost". Those are the costs that the designer causes to occur due to the design he selects. The influence of the design process on cost is the single greatest influence on product cost. The facilities that are available and the manufacturing techniques selected by manufacturing rate second to the designer effect on cost. The designer must be aware of and understand how his design selection is affected by the available facilities and manufacturing methods. There has been considerable written and said about the design and manufacturing interface required on composites, and there is no need to repeat that here. I will, however, add that I believe the need for this interface is much greater for composites than for metal structures. However, as the next chart illustrates, the designer is the key to real cost savings.

Structural Design Drivers

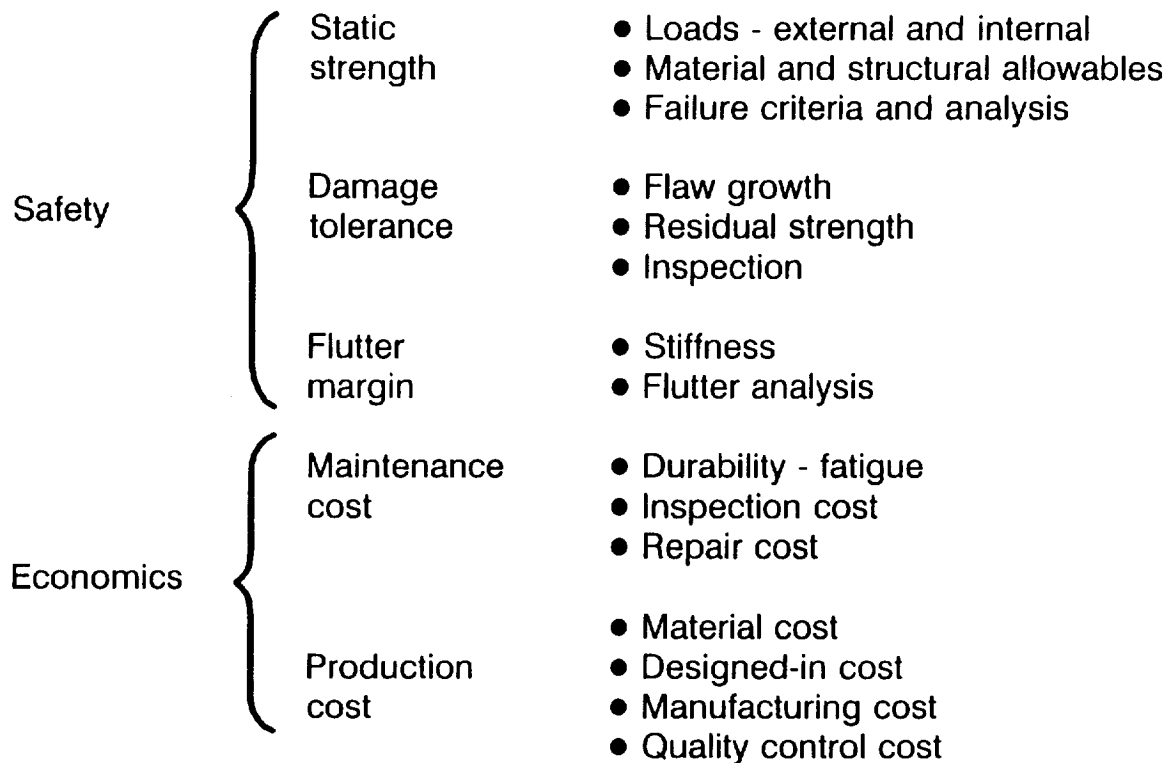

To allow the designer to make effective assessments of the cost of his design, he requires tools to do it in the same manner that he meets the other requirement displayed on this chart. This does not mean he must become a cost estimator, but he needs tools that allow him to make cost one of the tradeable items as he goes through the thought process for his design development. I believe that the post design cost evaluation by an estimator does not allow the same degree of design innovation as allowing the designer to work cost as one of his design parameters. Since the design process that selects from many options occurs at various design stages and detail levels, cost tools are needed at each stage and level. Real design cost improvement can be made if we provide the designer with real cost evaluation tools. These tools do not have to represent the dollar cost of the design, only the relative cost of one design approach to another. With such tools in the hands of the designers we will see considerable improvement in the “designed-in cost” of composite airframe structures.

Designer’s Tools

Design parameter	Designer’s tools	Design incentives
Safety (strength)	$f_b = \frac{Mc}{I}$ M.S. = $\frac{f_b}{F_b} - 1.0$	Regulators (FAA)
Durability	f_{max} , DFR, N reg	Warranty Service life
Weight	Density x volume = weight	Performance
Cost	?	Sales Profit



This weight and cost chart is an old one that we put together in the early 70's and has been used repeatedly by many people at Boeing. What it displays does not present anything different from what you would expect to see. The two major components each make up about the same percentage of the total structural weight. In a similar manner, the costs that are shown are as expected because of the size of these components; they are a high percentage of the total cost. The fuselage costs more because of its higher part count. However, when used in connection with the next chart, one can begin to assess where to work the weight savings the hardest and where to make cost the key design driver. These charts can tell you how to approach design solutions such as damage tolerance as well. The approach to each area of design can be initially established with this level of information. The distribution may vary in small percentages—commercial transport to transport—but not significantly enough to not allow for this information to provide guidance of some up-front design approach decisions to be made.

Weight and Cost Distribution

Commercial Aircraft

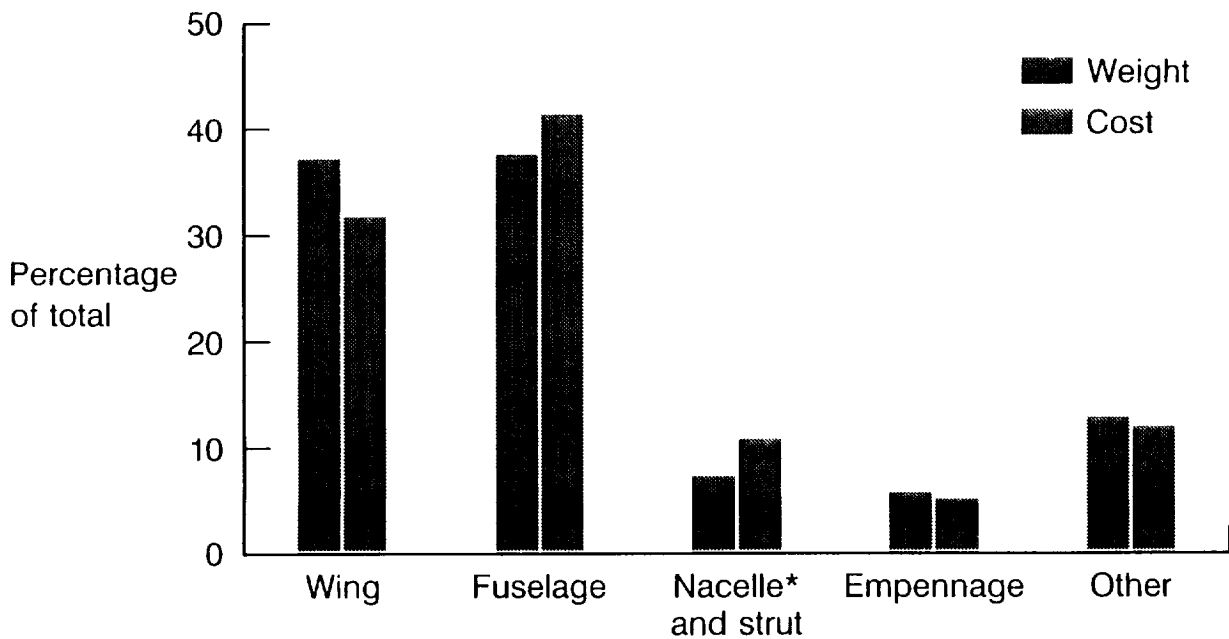

*Powerplant weight and cost excluded

A simple and perhaps extreme example of cost as the key driver, is the intermediate ribs. These ribs do not support any external attachments or form fuel bays. They simply maintain box shape and support the skin/stringers surface panels. They usually have their web gages set by fuel slosh and must maintain a reasonable stiffness to support the surface panels. These requirements limit their potential weight savings. Therefore, the chart assumption was only a 10% weight savings, which results in a negligible weight saving to the total airframe. However, in a study we did in the same time period that we generated these weight/cost charts, we found that on a dollar per pound basis these ribs were the most costly element of the wing. Therefore, some simple review of the weight and cost history can guide you, as it would for this example, to make cost the key design driver for intermediate ribs. This can be done in those early pay-off design phases previously discussed. Similarly, very obvious is the selection of the surface panels of the wing for weight saving potential. Since it is a large contributor to total cost, the design must also reflect the best cost options while allowing the maximum weight saving to be gained. Again, many early inputs to the design process can be made from simple information and design histories regardless of the material system. To most of you good composite designers in the audience this is nothing new.

Weight-Saving Areas Selection

	Structural element, %	Wing, %	Fuselage, %	Total aircraft, %
Wing				
● Skin and stiffeners	25	15.5		5.7
● Spars	20	3.0		1.1
● SOB	15	1.2		0.4
● Special ribs	20	1.0		0.4
● Intermediate ribs	10	0.4		0.0
● Center-section beams	20	0.4		0.0
		<u>21.5</u>		<u>7.6</u>
Fuselage				
● Skin, stringers, and frames	25		10.8	4.0
● Keel and wheelwell	20		3.2	1.2
● Floors and floorbeams	20		2.4	0.9
● Doors	15		1.7	0.6
● Bulkheads	20		2.0	0.7
● Windows	15		0.8	0.3
			<u>20.9</u>	<u>7.7</u>

● Aircraft total (wing and fuselage): 15.3%

There has been and continues to be much discussion about composite designs being “black aluminum” designs. The discussions say that if the designs were not so black aluminum looking we could save more cost and weight. This chart shows we should stop looking for the non-black aluminum. The geometry of the cross section of aircraft structures looks the way it does because those are the most efficient structural shapes. How those shapes are made out of composites is a separate issue from the shapes. Ply orientations and lay-up sequences are the real design differences with composite structures. These shapes were taken from an old paper, *Optimization of Multirib and Multiweb Wing Box Structure Under Shear and Moment Loads*, by Donald H. Emero and Leonard Spunt of North American. I have not shown all the cross sections displayed in that paper on this chart. If you can review that paper and come up with some additional cross sections of significant differences, I would like to hear from you. Let’s focus our development time on the real issues remaining to produce cost effective composite structures and not waste it looking for the non-black aluminum shape or geometry.

Structural Concepts



These two photo charts are shown to add to my just discussed issue of "black aluminum." The key surface panels of commercial aircraft are made of basically long skinny members and panels. I believe that again to look for something different is a total waste of development funds. The real question to be addressed with development funds is how to design these shapes for the low manufacturing cost while selecting those that will perform well structurally and save weight. The development of manufacturing methods along with the design of these shapes needs to be the focus. The manufacturing methods development must be focused not on just those methods that are simply the lowest cost (without the recognition that these methods must have the ability to produce these two shapes). Those manufacturing methods that do not, from the start, recognize the effects of commercial airframe size and these shape requirements will be a waste of development effort and funds. I want to be careful here and not to forget to say that as the manufacturing methods for these two factors are developed, there is a requirement for continuing development to improve and enhance the structural data base and analysis tools. They offer the means of opening the options door to the fullest for the design engineer.

Structural Elements

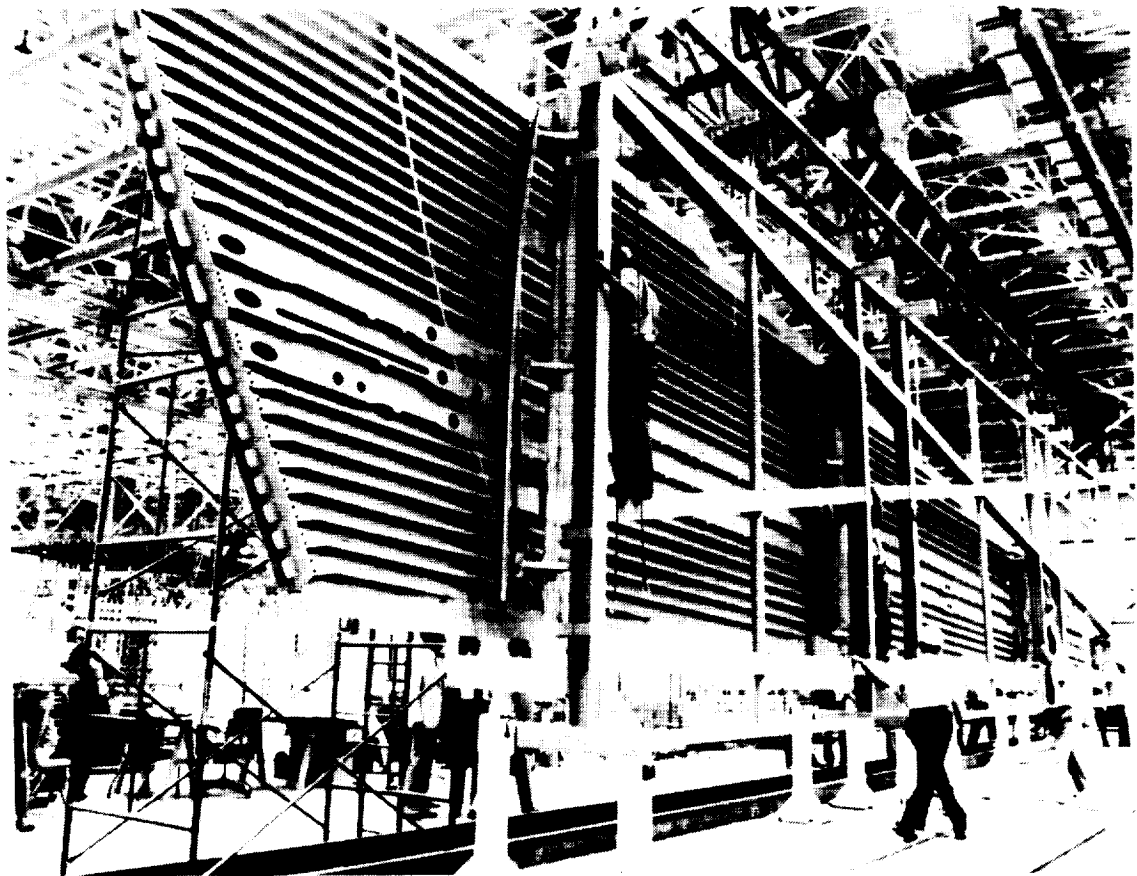

Wing Skin and Stringers

Fuselage Skin, Stringers, and Frames

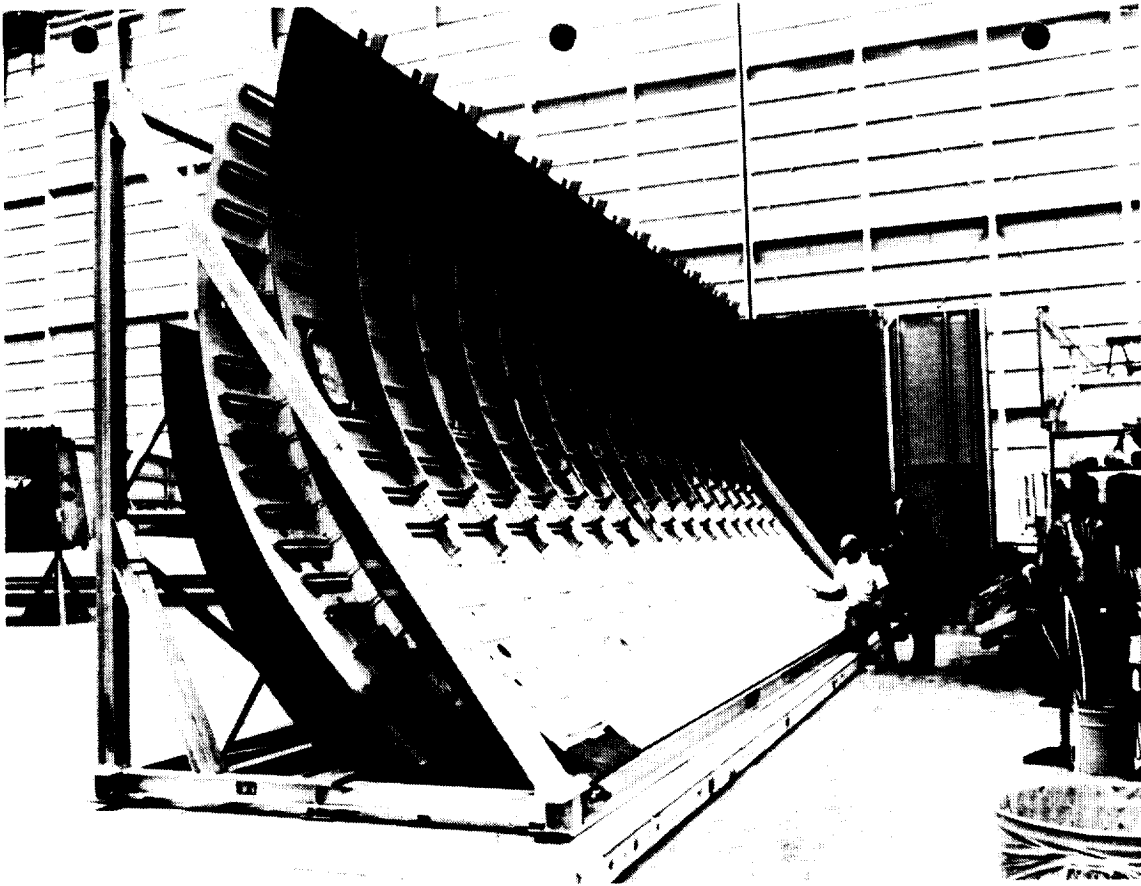

ORIGINAL PAGE
BLACK AND WHITE PHOTOGRAPH

I have just made my case for not looking for the non-black aluminum designs and the recognition of the key structural elements. These charts validate that industry is effectively doing that in spite of continuing discussion of looking for non-black aluminum designs. We have developed the tape laying machine that does in effect the same job that the skin mill does. In the next chart we are developing pultrusion machines we hope will make long skinny members like we machine on spar mills. I present these pictures to show you have already recognized what I just previously said. To improve on that you should continue to look further at the processes that can produce these required shapes. I believe we have to take the correct steps while allowing the non-knowledgeable to continue to look for the wrong thing, non-black aluminum designs. We need to focus our effort on continuing to explore new manufacturing methods that can reduce the cost of making the real structural shapes required.

Metal and Composite - Skins

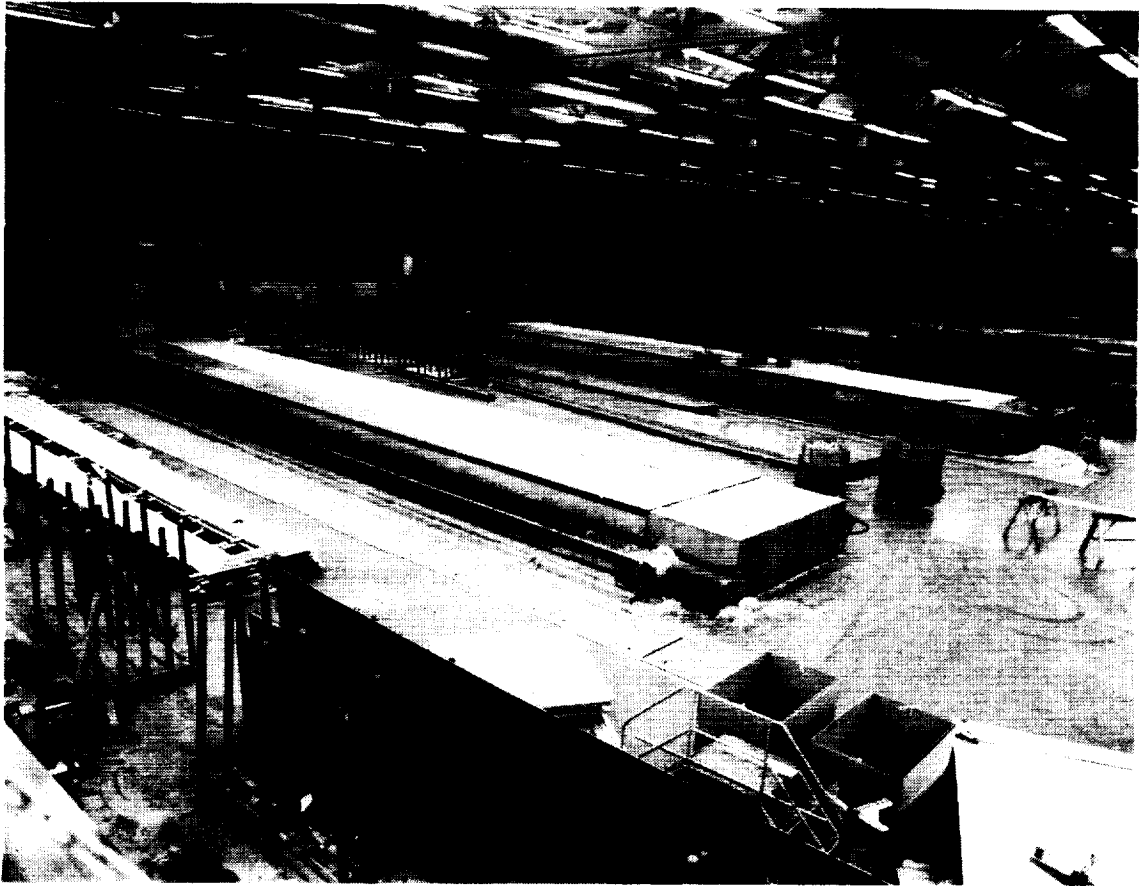

Skin Mills

Tape Layup Machine

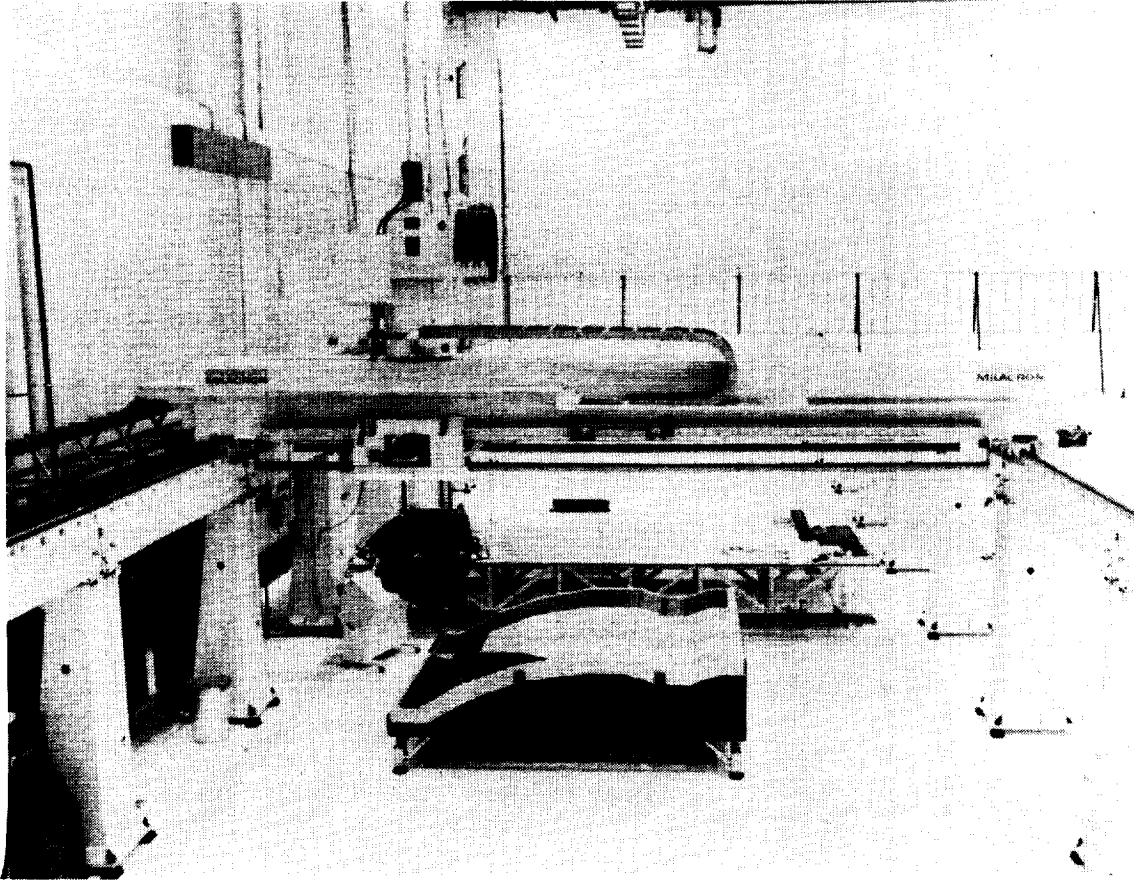

ORIGINAL PAGE
BLACK AND WHITE PHOTOGRAPH

No additional discussion is needed for this chart in addition to information presented previously. Let's just keep a continued focus on the right manufacturing methods development. The following charts will show that we have at least as many options as metals, if not more.

Metal and Composite – Stringers

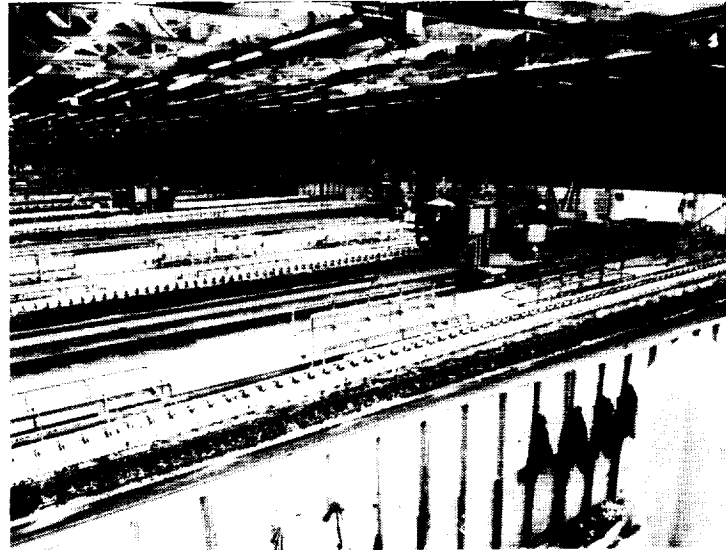

Spar Mills

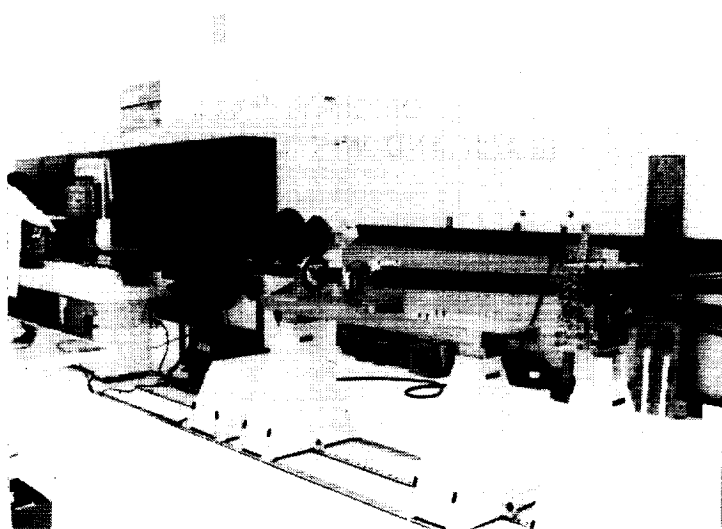

Pultrusion Machine

In continuing to address the cost issues the question often arises as to the structural and manufacturing options available with composites. They are still viewed by some as a new structural system, but I am certain not by those of you in this audience. A reduced set of structural and manufacturing options seem to be implied. This may be limiting the usage of composite structural applications. These two charts are presented to show simply that I don't see it that way and that the options in both cases are equal. We have yet to see all that might become available for composites. We may still have some development or learning to apply to what I show here, but I believe they are all possible.

Structural Options

Options	Metal	Composite
● Joining		
● Mechanical	*	*
● Bonding	*	*
● Integral	*	* (Cocure)
● Configurations		
● Skin and frame	*	*
● Skin, frame, and major longerons	*	*
● Skin, frame, and stringer	*	*
● Honeycomb and frame	*	*
● Honeycomb shell	*	*
● Grid stiffened and frame	*	*
● Grid shell	*	*

This chart makes a similar statement about the fabrications options available for composites. Neither of these charts is said to be complete in terms of all possibilities but to be reasonably representative of the current development status.

Form and Fabrication Options

Metal	Composite
● Element forms	
● Sheet and plate	Tape layup and filament winding
● Extrusion	Pultrusion
● Forging	Resin infusion
● Shaping	
● Roll forming	*
● Hydropress	Hot forming and thermoplastic
● Machining	Hot forming and thermoplastic
● Stretch forming	Aligned discontinuous fibers and thermoplastic
● Joining	
● Mechanical fastening	*
● Bonding	*
● Diffusion bonding	Cocuring
● Welding	Thermoplastic fusion

From the two previous charts I tried to show that the composite designer has the same degree of options open to him as the metal designer. The manufacturing methods offer the same level of options. I did not say that the manufacturing methods were equal in cost or efficiency. Metals manufacturing has a considerable head start in both the development and applications aspects of the methods. This chart addresses an applications aspect that may sometimes be overlooked when making cost comparisons. This chart shows that the learning curve, I believe, is not straight as often depicted by the dashed line, but is more like the solid line. The solid line shows that in the production of the first 30 to 40 aircraft there is little so-called learning going on. This is due to the high number of changes that usually occur as the aircraft goes into production and both engineering and manufacturing correct their mistakes. The steep slope indicates that changes are reduced and the real people-learning takes place. This is followed by a lower but continuing reduction in man-hours per aircraft. This slope does not represent any continued people-learning improvements but those improvements due to manufacturing methods and tooling changes that are made to reduce cost. These changes are only made when the cost savings can be shown to be effective over the remaining production run. These changes and ideas are carried forward to the next design. The point of the chart is that this carry over is not zero for composites but it does not have the years of background that metals have available. While the composites are not at zero as I show (relative to the final slope), they are so close to that for commercial transport major components that it represents the real position relative to the metals for 50 to 60 years. This number of years' difference makes it very difficult for composites to compete on cost alone.

Learning Curve

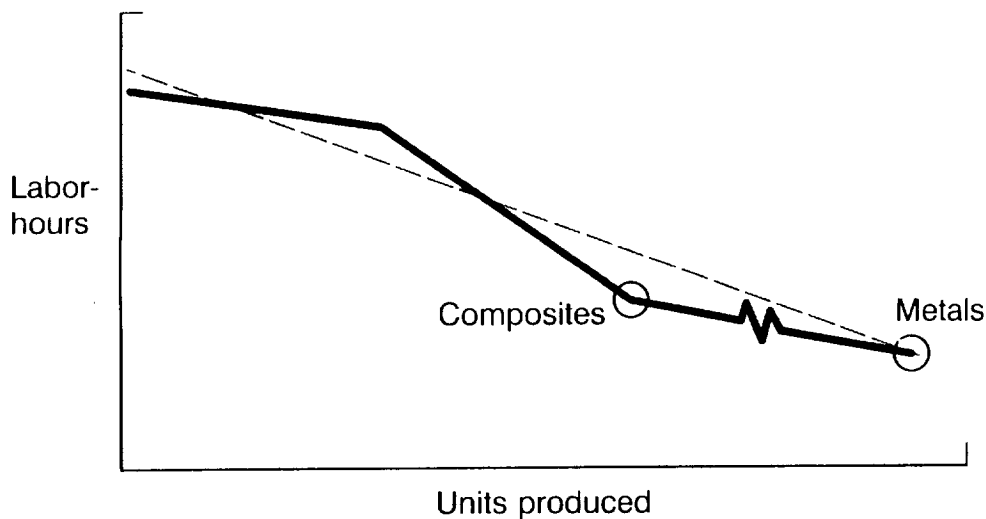

This chart suggests one of those areas that can be addressed now, and I do not believe it is being addressed in competition with metal. If I need a clip or short stiffener of composite material, it is usually manufactured for that specific location and usage. In metals I have standards books of extruded shapes and possibly a set of rolled shapes. From these I can often select what I need. If one looks at the many uses of clips or brackets and web stiffeners used in aircraft, one wonders why a supplier has not come forward for this structural element. A large number of metal extrusion dies have been developed over the years just noted. Maybe it's time to start something similar in composites. I made a very rough estimate of the number of short stiffeners or attachment clips on a commercial transport. My estimate is that more than a million feet per year would be needed based on 10, 767 size airplanes a month. If a simple angle were produced in a standard lay-up and angle, say 90 degrees, there are many locations where it could be used. It is possible that if that angle were made of thermoplastic, it could be used for angles other than 90 degrees by placing it in a heated die to change the shape angle. If there are other items to be addressed as composite structural standards, I leave that to this audience.

Stiffeners - Requirements

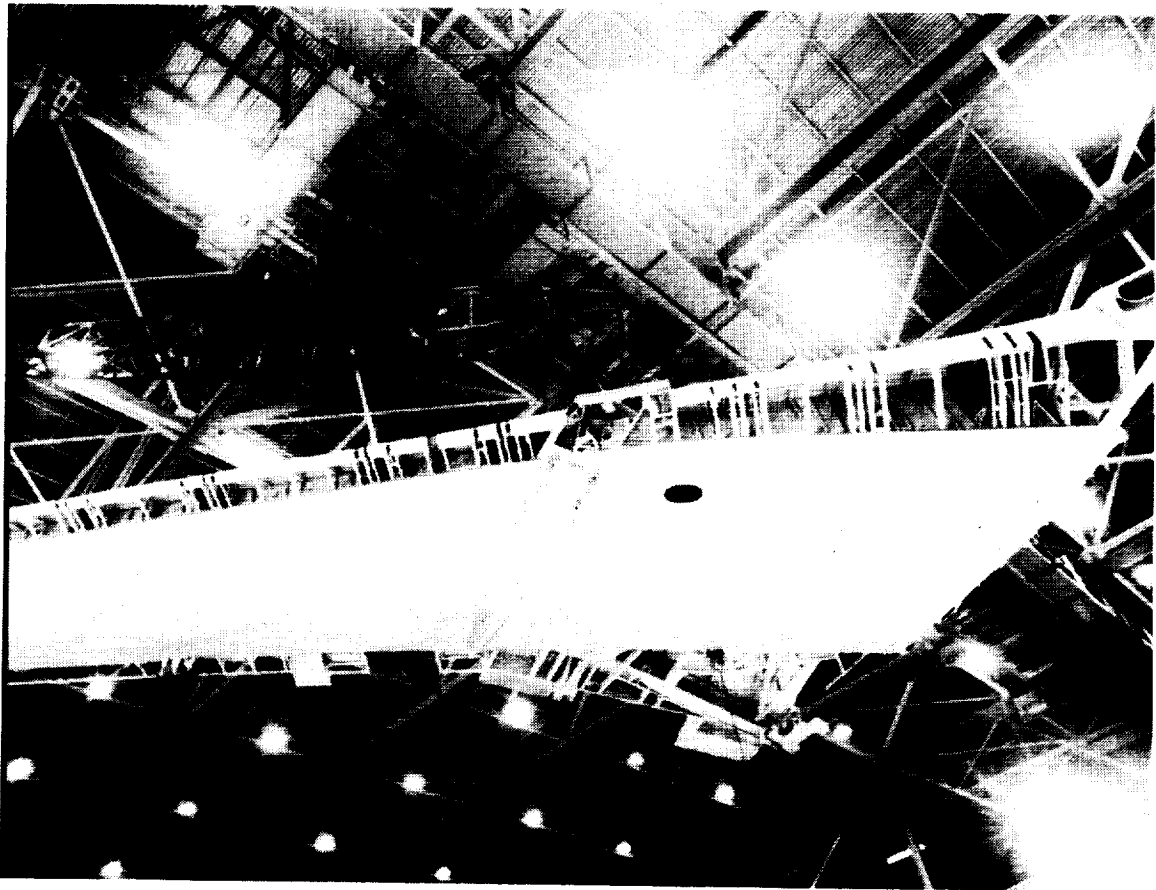

Spar Stiffeners

ORIGINAL PAGE
BLACK AND WHITE PHOTOGRAPH

Floorbeam Stiffeners

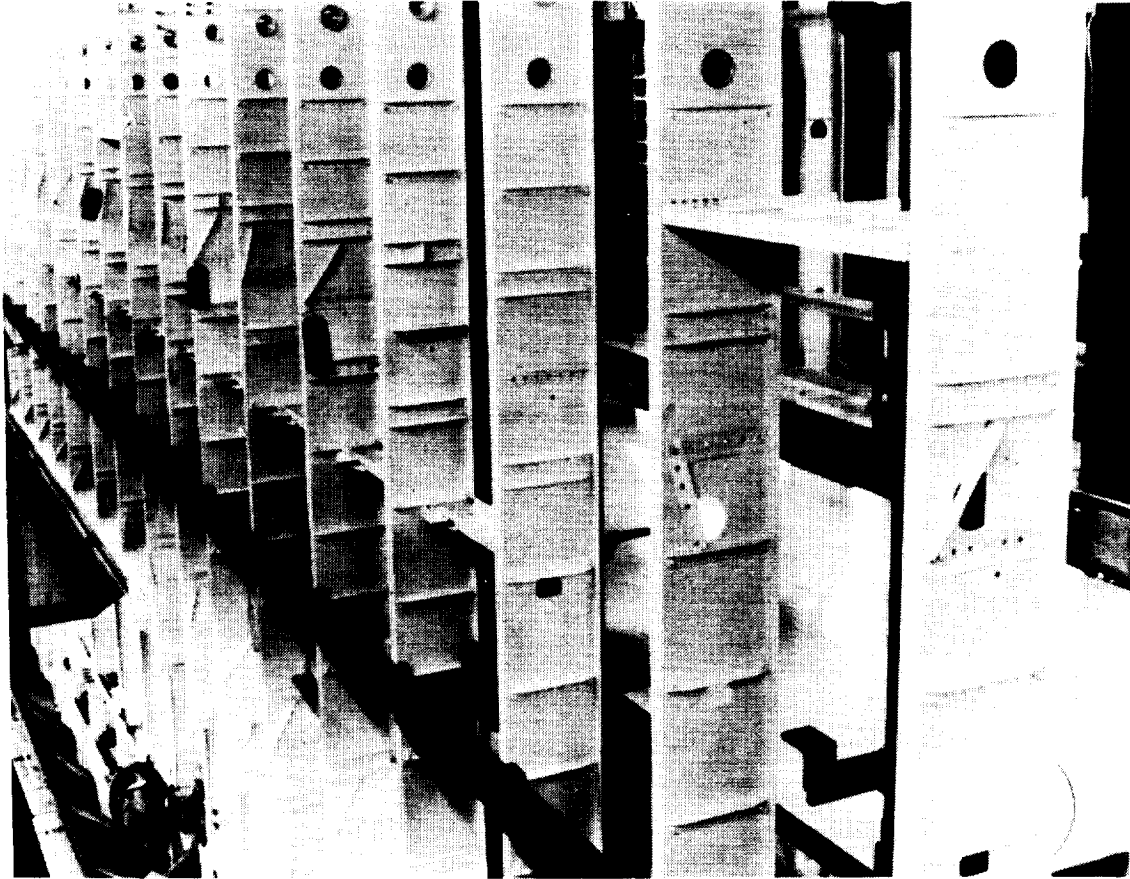

ORIGINAL PAGE
BLACK AND WHITE PHOTOGRAPH

We are hearing a lot about the cost of composite materials and that it is difficult for composites to compete with aluminum on the basis of just the basic material cost alone. This chart is based on some data from a NASA document looking at the cost of composite material relating to type of composite material. I have taken that data and ratioed it to the cost of aluminum. The displayed ratios agree that composite material costs are high. When we have ratios this high in comparison with aluminum it is difficult for composites to compete on a cost basis. However, I offer the right hand graph on this chart as another look at this cost ratio. If we consider the out-the-door cost of the materials rather than just the in-the-door cost, we get a different picture. For wing skins, we order special large roll taper skins, and we often machine away 60 to 70 percent of the material. For certain airlines that like shiny fuselage skin, we order premium sheet. Neither of these elements, that are part of the previously shown major weight contributors, are purchased at the base price of aluminum. Second, when we consider the 60 to 70 percent chips in the machined skins (even with the 50-a-pound resale on the chips) the cost ratios are significantly altered for the out-the-door cost ratios. I should note that my comparison on material cost only addresses the material cost and amount used; no labor is included. The general utilization of composite materials is in the 120% range. That is, we need 120% of the out-the-door weight in-the-door to make the parts. This comparison changes the ratio to about 20 to 30% of the in-the-door ratio between aluminum and composites. Let's be sure we recognize this aspect before we say how expensive composite materials are as compared to metals.

Material Cost Comparison

Composite Versus Metal (Aluminum)

Metals (Aluminum) and Composites Cost Ratios

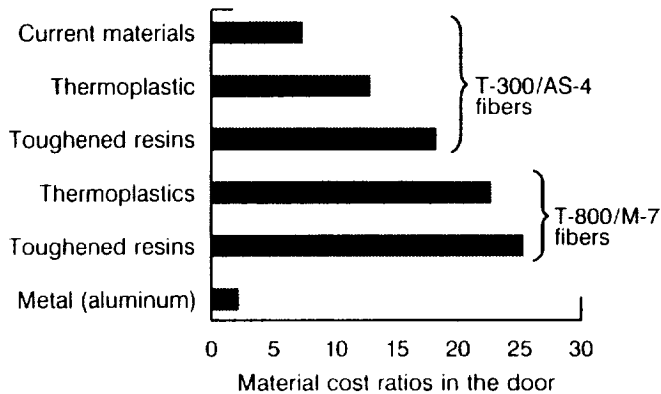

Material Usage

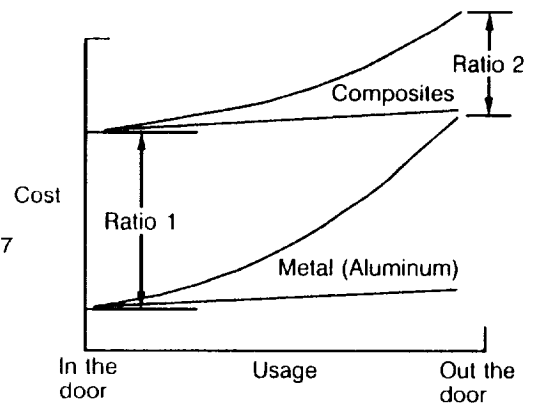

While I have just defended the cost of composite materials, I would like to send a message to the material suppliers here by again using a chart from a NASA report. If this chart is right, and I believe the trend it shows is correct, then the suppliers need to examine their marketing approach and recognize the business potential out there for them if the price of composite materials can be reduced. The reduction in cost can make the application expand to the major structural elements of the airframe, namely the wing and fuselage. I believe continuing effort on the part of the suppliers is needed and should be part of all future research and development. The airframers need to continue to clearly define their needs and their manufacturing approaches, while the supplier needs to identify the items in the airframer's requirements that are the key cost drivers in the product. They, of course need to, on their own, continue to look for ways to reduce their cost so they can pass it on in the reduced price of composite materials. The market target potential is so large with the development of an all composite commercial transport that this cost aspect is as important as any needing attention.

Composite Material Usage Projection of Potential Usage

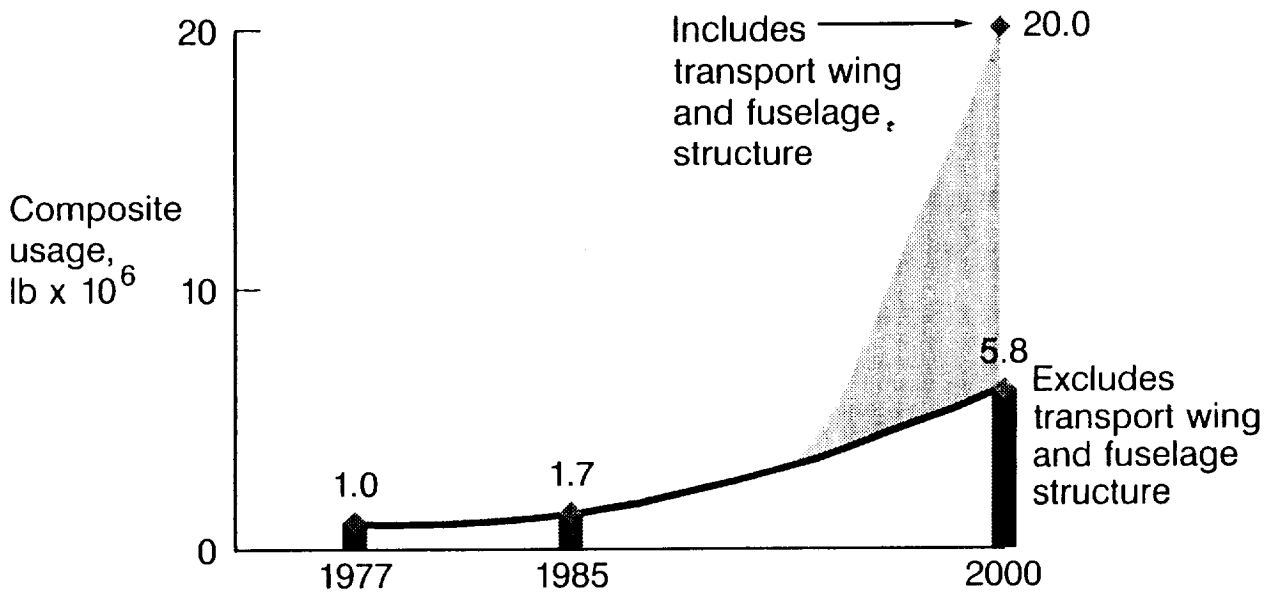

All of us here, as well as those involved in the development of composite structure, have, I am sure, tried to dream up as many reasons possible that composites produce benefits to both the airframe manufacturer and the aircraft user. The ones I have selected here I believe are real. They are either well defined today for composites or will be in the future when fully applied to the commercial transports. We have shown over and over again we can save weight, and you have heard that again at this conference. The performance resulting from that saving certainly can produce fuel saving and again, in today's world climate, that is becoming an issue for the airlines. In terms of maintenance the fatigue characteristics of composites will continue to reduce the fatigue maintenance requirements significantly. The area that composite structures has not received enough benefits credit for is the area of corrosion. Many dollars go into the airframe manufacturing process for the addition of corrosion protection of the structure. Similarly, the airlines spend many dollars maintaining this corrosion protection in their fleets. The use of composites eliminates a major portion of this requirement for corrosion protection. The chart on the right shows only a small part of the corrosion protection applications applied to Boeing aircraft. Finally, I believe as we continue our learning process in how to produce large commercial transport composite structures, we will see more and more opportunities to reduce the cost of composite structures and accrue additional benefits.

Composite Application Benefits

- Performance improvements - weight saving
 - Fuel savings
 - Improved DOCs

- Reduced maintenance
 - Large reduction in fatigue problems
 - Corrosion maintenance greatly reduced

- Potential manufacturing cost reduction
 - Better material usage
 - Reduced assembly (more monolithic parts)

As noted, this chart does not show all the corrosion protection areas for commercial transport (which is a significant cost item in the manufacture and maintenance of the aircraft).

Corrosion Protection and Maintenance

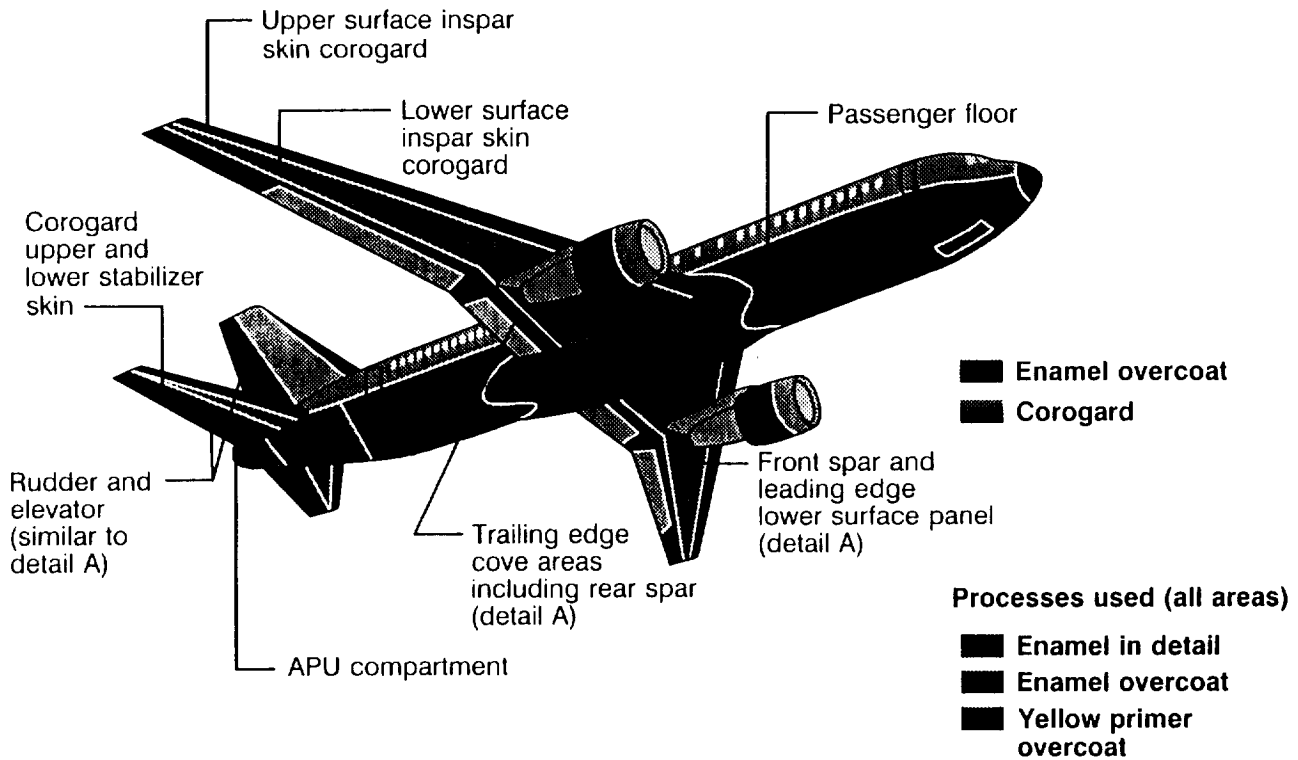

Where are the key development needs? As I see it, this list presents my best assessment of the continuing development needs as they relate to commercial transport aircraft. I am sure that not everyone will agree with this list, but I believe it encompasses some of the key needs. Many at this conference have talked about the cost of composite structures, and I have briefly addressed it today. Cost may represent the largest stumbling block to the application of composites to commercial aircraft. The large pressure shell considerations are the key concerns for the application of composite to commercial aircraft fuselages. The Aloha Airlines incident of a couple of years ago keeps before us the fatigue and pressure issue in metals and reminds us not to short change those same issues in composites. If we expand the use of composites, we will surely want to raise the strain levels used with time, and in doing so, the low strain level of usage we have employed previously will not provide the error protection of the past. Therefore, we need to continue to expand our knowledge on the issues of fatigue and flaw growth, even if we plan to design to a “no growth” approach with composites. Finally, for commercial transport aircraft certifications we need to continue to address the issue of the effect of environment on composite structure full scale validation tests. Also, the issue of proof of the “no growth” approach needs very careful review. I believe the enhanced loads approach to be totally wrong; therefore, I included this issue in the needs list of areas for continuing development support.

Composites Continuing Development Development Needs

- Material cost reduction
- Manufacturing cost reduction
- Fuselage pressure shells - damage tolerance
- Industry accepted - failure theory
- Effects higher strain utilization
 - Fatigue
 - Flaw growth
- Certification - additional validation of -
 - Ambient full-scale testing
 - Flaw “no growth” approach

This chart is one that an oldtimer has the privilege of presenting. The whys and wherefores of these dates are many and well developed by my personal prejudices on composites, but I thought I would leave them with you as reasonable targets and challenges for the commercial airplane people in the audience.

I again want to thank NASA for inviting me to make this presentation and to say thanks to those many friends at NASA who have helped me over the years. Also my thanks goes to those of you in the audience that I have worked with on committees and contracts that have helped me and been my friends for these many years in composites. And, of course, to many associates and friends at Boeing who are here, thanks for your great support and help over the years. I hope that all the goals of the ACT program are achieved and the benefits well recognized by the non-technical community as well as by the technical community.

Application Projections

Large Commercial Transports

- **Complete composite structures**
 - **Wing - before year 2000**
 - **Fuselage - by year 2010**

