



Operation of the Helicopter Antenna Radiation Prediction Code

E.W. Braeden, F.T. Klevenow, E.H. Newman, R.G. Rojas, K.S. Sampath,
J.T. Scheik and H.T. Shamansky

N93-31110

Unclas

G3/32 0174966

The Ohio State University
ElectroScience Laboratory

Department of Electrical Engineering
Columbus, Ohio 43212

(NASA-CR-193259) OPERATION OF THE
HELICOPTER ANTENNA RADIATION
PREDICTION CODE (Ohio State Univ.)
111 P

Technical Report 722792-4
Grant No. NAG-1-1058
June 1993

National Aeronautics and Space Administration
Langley Research Center
Hampton, VA 23665-5225

NOTICES

When Government drawings, specifications, or other data are used for any purpose other than in connection with a definitely related Government procurement operation, the United States Government thereby incurs no responsibility nor any obligation whatsoever, and the fact that the Government may have formulated, furnished, or in any way supplied the said drawings, specifications, or other data, is not to be regarded by implication or otherwise as in any manner licensing the holder or any other person or corporation, or conveying any rights or permission to manufacture, use, or sell any patented invention that may in any way be related thereto.

REPORT DOCUMENTATION PAGE		1. REPORT NO.	2.	3. Recipient's Accession No.
4. Title and Subtitle Operation of the Helicopter Antenna Radiation Prediction Code				5. Report Date June 1993
7. Author(s) E.W. Braeden, F.T. Klevenow, E.H. Newman, R.G. Rojas, K.S. Sampath, J.T. Scheik, H.T. Shamansky				6.
9. Performing Organization Name and Address The Ohio State University ElectroScience Laboratory 1320 Kinnear Road Columbus, OH 43212				8. Performing Org. Rept. No. 722792-4
12. Sponsoring Organization Name and Address National Aeronautics and Space Administration Langley Research Center Hampton, VA 23665				10. Project/Task/Work Unit No.
15. Supplementary Notes				11. Contract(C) or Grant(G) No. (C) (G) NAG-1-1058
16. Abstract (Limit: 200 words) HARP is a <i>front end</i> as well as a <i>back end</i> for the AMC and NEWAIR computer codes. These codes use the Method of Moments (MM) and the Uniform Geometrical Theory of Diffraction (UTD), respectively, to calculate the electromagnetic radiation patterns for antennas on aircraft. The major difficulty in using these codes is in the creation of proper input files for particular aircraft and in verifying that these files are, in fact, what is intended. HARP creates these input files in a consistent manner and allows the user to verify them for correctness using sophisticated 2 and 3D graphics. After antenna field patterns have been calculated using either MM or UTD, HARP can display the results on the user's screen or provide hardcopy output. Because the process of collecting data, building the 3D models, and obtaining the calculated field patterns has been completely automated by HARP, the researcher's productivity can be many times what it could be if these operations had to be done by hand. A complete, step by step, guide is provided here so that the researcher can quickly learn to make use of all the capabilities of HARP.				13. Report Type/Period Covered Technical Report
17. Document Analysis a. Descriptors AIRCRAFT ANTENNAS MOMENT METHOD b. Identifiers/Open-Ended Terms c. COSATI Field/Group				14.
18. Availability Statement A. Approved for public release; Distribution is unlimited.		19. Security Class (This Report) Unclassified		21. No. of Pages 108
		20. Security Class (This Page) Unclassified		22. Price



HARP USER
MANUAL

XD88 SERIES
SYSTEM USER'S GUIDE

Please check for CHANGE INFORMATION at the rear of this manual

First Printing NOV 1992
Revised FEB 1993

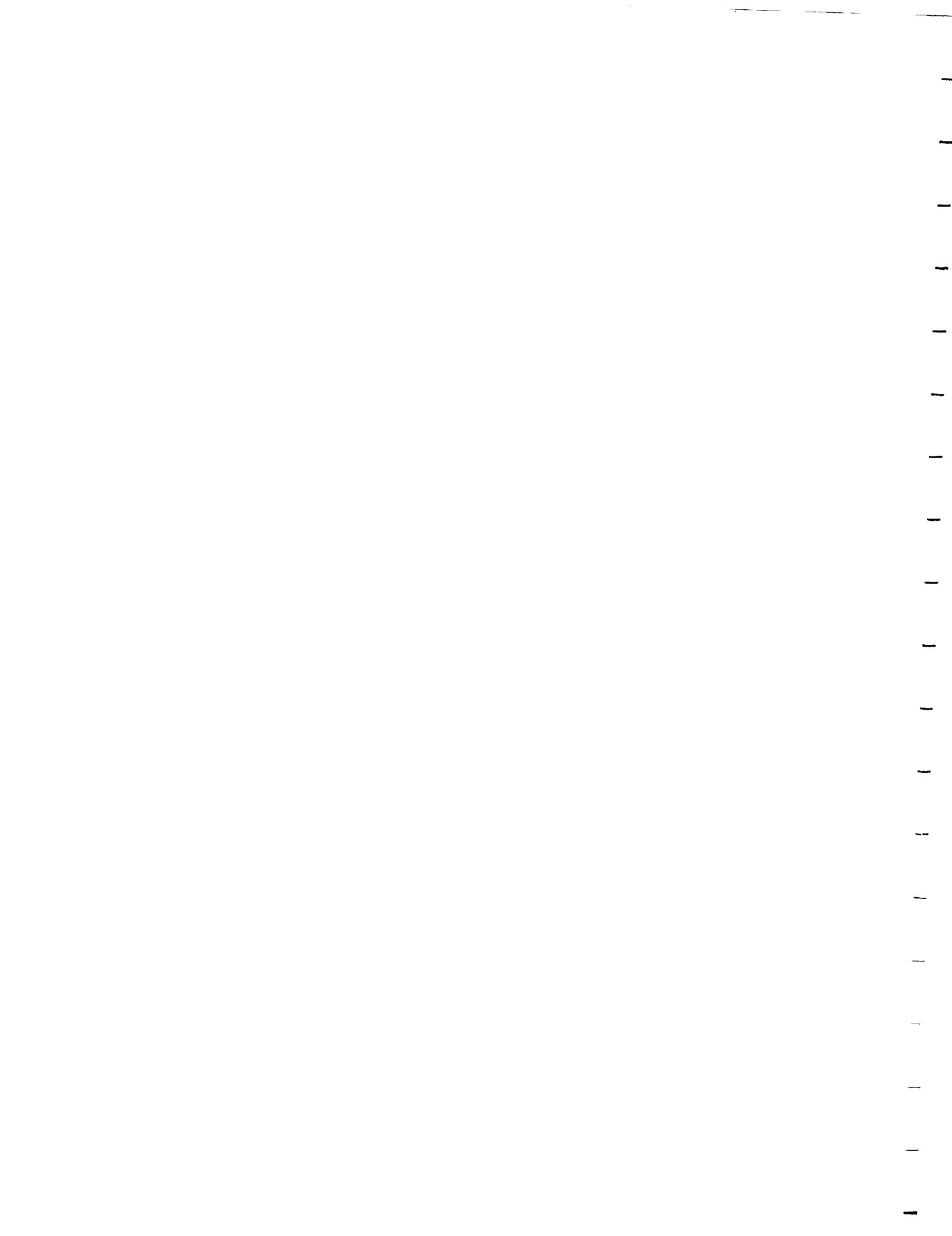

MANUAL REVISION STATUS

PRODUCT: HARP for Tektronix

Supporting the following versions of HARP: Release 1.85 and up.

REV DATE	DESCRIPTION
NOV 1992	Original Issue.
FEB 1993	New Features.

Contents

1 Preliminaries	1
1.1 What is HARP?	1
1.2 Assumptions About the Equipment	2
1.3 Assumptions About the User's Experience	3
1.4 How This Guide is Organized	3
1.5 How to Use This Guide	3
1.6 Notational Conventions Used	4
1.7 HARP Menu Structure	5
I HARP: Quick Overview	7
2 Getting Started	8
2.1 [1] Generate Body Geometry	10
2.2 [2] Change Working Directory	11
2.3 [3] Utility Functions	11
2.4 [4] Generate/Display Model(s)	13
2.5 [5] Calculate Radiated Fields	14
2.6 [6] Display Calculated Results	15
2.7 [E] Exit HARP	15
II HARP: In Depth	16
3 [1] Geometry Entry Menu	17
3.1 1_1 Enter Body Cross-sections	17
3.2 1_2 Build / Modify Master File	24
HARP User's Guide	ii

CONTENTS

3.3	1_3 View Default Body Silhouette	28
3.4	1_4 Interpolate Cross-section	28
4	[3] Utility Menu	30
4.1	3_1 Inquire/Set Family Name	30
4.2	3_2 Set User Preferred Units	31
4.3	3_3 Exit HARP to Your Shell	32
4.4	3_4 Submit Bug Report	32
4.5	3_5 Predict MM Completion	33
4.6	3_6 Archive/Recover Data	34
4.7	3_7 Write Status File to Disk	37
4.8	3_8 Set Temporary AMC Defaults	38
5	[4] Model Comparison Menu	40
5.1	4_1 Add/Display Physical Features	40
	5.1.1 Fin Operations	41
	5.1.2 Antenna Operations	48
	5.1.3 Rotor Assembly Operations	49
5.2	4_2 Generate/Display MM Input Model	51
5.3	4_3 Calculate UTD Ellipsoid	55
5.4	4_4 Calculate UTD Plates	59
5.5	4_5 Display UTD Body	60
5.6	4_6 Enter Towelbar Antenna	60
6	[5] Field Calculation Menu	62
6.1	5_1 Build/Show MM Graphics	62
6.2	5_2 Do MM Calculation	64
	6.2.1 Specifying the Pattern Cut	64
	6.2.2 Saving and Reusing the MM Impedance Matrix	65
6.3	5_3 Do UTD Calculation	70
7	[6] Field Display Menu	71
7.1	6_1 In-situ Plot MM Results	71
7.2	6_2 In-situ Plot UTD Results	71
7.3	6_3 Hard Copy MM Results	72

CONTENTS

8 Complete Examples	76
8.1 Entering the Cross-Sections	76
8.2 Building the Master File	80
8.3 Adding Fins, an Antenna, and a Rotor	82
8.4 Building the MM Model	85
8.5 Making the MM Calculations	85
8.6 Building the UTD Model	87
8.7 Making the UTD Calculations	88
8.8 Field Plots and Hardcopy Output	89
Bibliography	92
A Dial Box and Function Keys	93
B The HARP Executable Images	96
C Data Files Used by the HARP System	98
D HARP Directory Tree	101
Index	103

Chapter 1

Preliminaries

This work is meant to be a guide to the use and operation of the Helicopter Antenna Radiation Prediction code (HARP). It is designed to accomplish the following objectives:

- Serve as a quick reference to the operations of HARP.
- Provide clear instruction on how to use HARP.
- Give the user background information about the ordering of certain tasks.
- Provide a list of the executable images that are tied to each of the HARP menu options.
- Provide a list of the files HARP creates for data as well as error processing.

1.1 What is HARP?

HARP is a *front end* as well as a *back end* for the "Aircraft Modeling Code" (AMC) [1] and the "Airborne Antenna Radiation Pattern Code" (NEWAIR) [2] computer codes. These codes use the Method of Moments (MM) and the Uniform Geometrical Theory of Diffraction (UTD) methods, respectively, to calculate radiation patterns for antennas on aircraft constructed from perfectly conducting surfaces. In brief, AMC is a low frequency code which is

CHAPTER 1. PRELIMINARIES

most applicable when the body is not too large electrically. Running AMC for bodies which are more than several wavelengths in extent will result in excessively large computer memory and CPU time. AMC models an aircraft by a combination of thin wires (for the antenna and rotor blades) and polygonal plates (for the fuselage and wings/fins). NEWAIR is a high frequency code which is most applicable when the body is electrically large. Running NEWAIR on bodies smaller than a few wavelengths in extent will result in significant errors. NEWAIR models the aircraft fuselage by a composite ellipsoid near the antenna attachment point and employs flat plates for the remainder of the fuselage and for the wings and fins. Note that the two codes are complementary with respect to frequency. The operation of these codes will not be further discussed here except as these operations relate to HARP. The native operation of these codes and their theories of operation are discussed in separate user manuals available from the Ohio State University ElectroScience Laboratory [1, 2].

The major difficulty in using these codes is in the creation of proper input files for particular aircraft and in the verification that these input files are, in fact, what was intended. HARP creates the AMC and NEWAIR input files in a consistent manner and allows the user to verify them for correctness using 2D and 3D graphics. HARP can then display the calculated field patterns on the screen or provide hardcopy output. Because the process of obtaining field plots has been so automated by HARP, user productivity can be many times what it is when the input files must be created by hand. Great effort has been made to take what was once a difficult, time consuming, or even impossible task, and turn it into one that is easy, quick, and consistent. This is the major contribution of HARP.

1.2 Assumptions About the Equipment

- A Tektronix XD88/30 or XD88/35 Workstation running the UTek V Release 3.2c operating system (UNIX).
- A Tektronix 4957 digitizing tablet or equivalent.
- A Tektronix eight control, LCD dial box.

CHAPTER 1. PRELIMINARIES

1.3 Assumptions About the User's Experience

It is also necessary that the user have the following minimal knowledge so that proper and useful results can be expected:

- A user knowledge of the Tektronix XD88 Workstation running the UTek V Release 3.2c operating system (UNIX).
- An understanding of the relative limitations and strengths of the Method of Moments and Uniform Theory of Diffraction approaches to solving electromagnetic radiation problems.

1.4 How This Guide is Organized

There are two main parts to this guide:

Part 1 contains a quick overview of all HARP operations possible from the menu system.

Part 2 contains support information about each of the HARP operations in more detail with emphasis on what is happening and how each operation works with the others. Complete examples of HARP in action are also provided in this part.

1.5 How to Use This Guide

1. Use Part 1 to begin. Each menu item is tied to an operation. These operations can be invoked even if the user is not sure exactly what will happen. If HARP is unable to carry out an operation, the user will be provided a brief message stating the problem or providing a suggestion for further action.
2. Use Part 2 to learn more about what is actually happening when a HARP operation is executed. How each of the operations is tied to the others is also described in detail.
3. As more experience is gained, use this guide for reference.

1.6 Notational Conventions Used

In this guide the main menus will be denoted in square brackets. Thus, the fourth menu would be referred to as Menu [4]. Each of the options within a menu will be referred to using two numbers. The first number denotes the menu in which the option is located. This number is then followed by an underscore and, finally, the option number for that particular item. Thus, the fifth option in Menu [4] would be called Option 4_5. HARP is not case sensitive to user input that requires a "yes/no" response. Another convention used here is that computer output to the screen will be preceded by \Rightarrow . Possible user's responses to these questions will be boxed like this:

italics

1.7 HARP Menu Structure

HARP Main Menu

- Option 1 >>> Generate Body Geometry
- Option 2 >>> Change Working Directory
- Option 3 >>> Utility Functions
- Option 4 >>> Generate/Display Model(s)
- Option 5 >>> Calculate Radiated Fields
- Option 6 >>> Display Calculated Results
- Option E >>> Exit HARP

[1] Geometry Entry Menu

- Option 1 >>> Enter Body Cross-sections
- Option 2 >>> Build/Modify Master File
- Option 3 >>> View Default Body Silhouette
- Option 4 >>> Interpolate Cross-section

[3] Utilities Menu

- Option 1 >>> Inquire/Set Family Name
- Option 2 >>> Set User Preferred Units
- Option 3 >>> Exit HARP to your Shell
- Option 4 >>> Submit Bug Report
- Option 5 >>> Predict MM Completion
- Option 6 >>> Archive/Restore Data
- Option 7 >>> Write Status File to Disk
- Option 8 >>> Set Temporary AMC Defaults

[4] Model Comparison Menu

- Option 1 >>> Add/Display Physical Features

CHAPTER 1. PRELIMINARIES

Option 2 >>> Generate/Display MM Input Model

Option 3 >>> Calculate UTD Ellipsoid

Option 4 >>> Calculate UTD Plates

Option 5 >>> Display UTD Body

Option 6 >>> Enter Towelbar Antenna

[5] Field Calculation Menu

Option 1 >>> Build/Show MM Graphics

Option 2 >>> Do MM Calculation

Option 3 >>> Do UTD Calculation

[6] Field Display Menu

Option 1 >>> In-situ Plot MM Results

Option 2 >>> In-Situ Plot UTD Results

Option 3 >>> Hardcopy MM Results

Option 4 >>> Hardcopy UTD Results

All operations possible with the HARP system are accessed through these menus.

Part I

HARP: Quick Overview

Chapter 2

Getting Started

To run HARP the user must be logged into a Tektronix XD88 on the main display terminal. In addition, the HARP executable images must be in the user's directory path and the user must have execute access to these files. Before starting a new project it may also be useful to create a new directory for the files that HARP will create. In any case, the user must have the proper read and write access to the directory where the HARP work is to take place.

Before starting HARP the user must be in a Tek Peer or Tek Window, or Tek Screen. This is accomplished by typing one of the following:

1. tekscreen
2. tekinit

The first of these choices utilizes the entire screen. The second choice opens a smaller TekGraphics window in the middle of the screen. This second option allows ready access to the user's standard environment so that other work may continue while HARP is being run.

Once the appropriate graphics window has been opened, HARP can be started by typing the following at the prompt:

```
$ harp
```

At this point HARP will do some initializations and display the main menu selections. In this mode HARP is capable of many 2D and 3D graphics operations based on STI, the Tektronix graphics system. Many of the HARP operations *must* use this graphics capability. However, once the aircraft models

CHAPTER 2. GETTING STARTED

have been created, most HARP operations, including all the electromagnetic calculations, can be done without this graphics capability. For users logged into the workstation from an Xterminal, a vt-type terminal, or another machine with an xterm or other vt-terminal emulator, a non-graphics option is provided so that HARP can run with almost all the functionality enjoyed by users logged into the main display system. For this option the user would type the following at the prompt:

```
$ harp -ng
```

In this case the user would be presented with identical menus and options as before except those menu items not possible due to graphics limitations would be *'d out and not accessible. This option brings the functionality of HARP to many more users than would otherwise be possible.

From the HARP Main Menu there are six options that can be selected:

- Option 1 >>> Generate Body Geometry
- Option 2 >>> Change Working Directory
- Option 3 >>> Utility Functions
- Option 4 >>> Generate/Display Model(s)
- Option 5 >>> Calculate Radiated Fields
- Option 6 >>> Display Calculated Results
- Option E >>> Exit HARP

All of these options, except for Options 2 and E, place the user in a second level menu where various options are logically grouped together to accomplish related tasks. All operations possible with HARP are accessed through this main menu. Therefore, each option in this main menu represents a second level menu except for Option 2 and Option E. Most of the HARP operations must take place in a specific order for correct results to be achieved. Great effort has been made so that if an illogical or incorrectly ordered operation is attempted, the user will be notified that this has occurred with an appropriate message and/or option to continue. There are twelve acceptable

CHAPTER 2. GETTING STARTED

inputs from the HARP Main Menu. Typing any number from [1] through [6] followed by [return] will select that numbered option. To exit the HARP system, type [E] or [e] followed by [return]. Two additional acceptable inputs are [V] and [v] followed by [return]. This *hidden* option prints the HARP version number on the screen along with other relevant data. The last two inputs are also for a *hidden* option. Typing [C] or [c] followed by [return] will clear any graphics image on the screen at *any* major HARP menu. All other inputs cause the bell to sound. The user is then returned to this HARP Main Menu. Note that HARP is *not* case sensitive to inputs for menu selection or “yes/no” responses to questions.

2.1 [1] Generate Body Geometry

When entering a new geometry, this is usually the first submenu the HARP user will see. Selecting this option places the user in Menu [1]. From this menu the user can enter cross-sections of a particular aircraft into a HARP database by digitizing points that make up the cross-sections from a blueprint or other drawing using the Tektronix 4957 tablet . This action is initiated by choosing Option 1_1.

From this submenu the user also builds or modifies the master file for a given body by selecting Option 1_2. The master file is basically a file that contains a list of cross-sections files that make up the body of a given aircraft. This master file contains the list of files which contain the data used to loft the 3D body for both display purposes and the electromagnetic calculations. The HARP code takes the cross-section data in the files listed in the master file and interpolates or lofts between these cross-sections in a special way to build the 3D model of the aircraft fuselage. The master file *must* be built by exercising Option 1_2 before any graphics or field calculations can be made.

The third option in the first menu, 1_3, allows the user to see the top and side silhouette of the current default body after the master file has been made. The RED markers in the display represent the maximum extent in the data points in each active cross-section file for the particular silhouette view displayed. The GREEN lines connecting these points are linear segments between these points, i.e. they do not represent lofted data. This option allows the user to quickly see where each of the cross-sections is located. It also allows the user to determine where additional cross-sections should be

CHAPTER 2. GETTING STARTED

located. The aspect ratio of the displayed body is one to one with the actual data so the display shows a properly scaled silhouette. This 2D display acts as a quick visual check on the body geometry so that the user can correct any obvious problems before proceeding to more complex HARP operations.

Option 1_4 allows the user to create a new cross-section file from any two pre-existing cross-section files by making a linear interpolation between them at the position the user specifies along the axis of the aircraft. Extrapolations are also possible if the user specifies a position that is not between the specified cross-sections. This feature is useful for creating a blend between cross-sections from different aircraft so that hybrid models can be made. It can also be used to create cross-sections along a tapered part of an aircraft model.

2.2 [2] Change Working Directory

This Main Menu option immediately displays the present working directory and asks the user to specify a new directory. The new directory can be specified relative to the present one or an absolute directory specification can be entered. HARP will then display the new default directory and return to Menu [1]. With this option HARP can be started in any directory and the user can quickly change to another desired project directory without having to exit and restart HARP in the new directory. It should be noted, however, that HARP must have read and write access to many files. Therefore, the user must have the proper access to the current directory for HARP to function correctly.

2.3 [3] Utility Functions

Selecting this option places the user in Menu [3], the Utilities Menu. Here, six basic options are provided. Option 3_1 provides one way for the user to find out what the current family name is or to set a new one. HARP creates a great number of files for a given aircraft. While it is possible to work on a number of aircraft in the same directory, it is not recommended. Because all the files associated with a single aircraft have the same family name in common, HARP is able to automatically pick up the correct files

CHAPTER 2. GETTING STARTED

for a given aircraft even if more than one aircraft is being worked on in the same directory.

Distances digitized on the tablet or absolute distances the user may be asked to enter such as an antenna length can be given in meters, centimeters, feet, or inches. The default unit for distance can be set with Option 3_2. After the preferred units are set, whenever HARP needs a distance, it will automatically ask the user to enter those numbers in these default units. The default unit for distance can be changed at any time, even in the middle of building an aircraft body.

Option 3_3 allows the user to temporarily exit HARP to the default UNIX shell. This is useful when HARP has been started in a Tekscreen where there is no access to other windows. To return to HARP when finished, simply enter `exit` followed by `return`.

If Option 3_4 is invoked the user may enter a brief message describing a problem with HARP believed to be a bug. This message will automatically be sent to the harp-maintainer at The Ohio State University ElectroScience Lab via email.

Option 3_5 provides the user with an estimate of when electromagnetic field calculations done by the Method of Moments (MM) will be completed. This functionality is provided because these calculations can take minutes, hours, or even days to complete. Due to computer resource limitations, only one MM problem can be run at a time. By using this option the user can see how long a given run will take, and have an idea when the next job can be started.

With Option 3_6 the user has the ability to store all the files in a given directory with a specified *family name* in a single compressed file with a user-specified tag. At some later time the user can then restore all the files that went into this compressed file to their original form. When many changes are being made to the HARP database or when work has been completed on a given model, this option provides a "snapshot" capability so that the user can go back at any time to restore the complete "state" HARP was in at the time this option was exercised.

Option 3_7 is designed to remind the user of the status of the files with the *current family name*. The summary can either be written to a disk file or echoed to the user's screen. Unlike Option 3_6, this Option only saves the *summary* of the data in the family name files, not the files themselves.

Option 3_8 is used to set temporary defaults for the MM code that will

CHAPTER 2. GETTING STARTED

modify its printing and/or integration accuracy. Because the standard defaults are well suited for most jobs, it is anticipated that this Option will be rarely used.

2.4 [4] Generate/Display Model(s)

This option places the user in one of the most used HARP menus, Menu [4]. From here all physical, moment method, and UTD models are generated and displayed so that the user may visually verify their correctness. It is also in this menu that the input files for the AMC and NEWAIR codes are automatically created. It should be noted that before any of the options in this menu can be exercised, the master file must have been created by the appropriate actions in Option 1_2.

Option 4_1 allows the user to display the physical features of the model of the aircraft or to add or modify features such as fins, antenna location, or, for helicopters, the geometry of the rotor blades. Fin here is a general term to describe wings, horizontal and vertical stabilizers, and other aircraft control surfaces. For each of these three items, fins, antenna location, and rotor blades, the user is confronted with a sub-menu where there are three choices:

1. Use a data file for the item that already exists.
2. Enter new data for the item through direct entry or the tablet.
3. Forget about the item for now.

As usual, if an option is selected that does not make sense, such as wanting to use a fin file that does not exist, HARP will give a message and return the user to the appropriate sub-menu.

For relatively low frequency work (body less than several wavelengths in extent), the Moment Method model (MM) can be created and displayed by selecting Option 4_2. The wire and polygonal plate model displayed is that which is *input* to the AMC code. This option also creates the input file containing geometry and other instructions for the AMC code.

For high frequency work (body more than several wavelengths in extent), the moment method (MM) cannot be used to calculate the field patterns. The matrix equations that would need to be solved become far to large to

CHAPTER 2. GETTING STARTED

be solved on an XD88. Therefore, at higher frequencies, the NEWAIR code based on the Uniform Theory of Diffraction (UTD) is used. The NEWAIR code calculates the field patterns by computing the radiation from a composite ellipsoid that approximates the surface of the aircraft in the vicinity of the antenna and a set of flat plates that model the rest of the aircraft. Note that the composite ellipsoid is formed by joining two ellipsoids at the antenna location in such a way that the vectors tangent to the surface are continuous across the junction. After the antenna location has been selected using Option 4_1, this composite ellipsoid is calculated by selecting Option 4_3. Before any other UTD operations can be performed, this step must have been successfully completed. In many cases, especially with helicopters, the composite ellipsoid is not sufficient to model the fuselage of aircraft. To remedy this deficiency, flat plates can be generated with Option 4_4, which are added to the composite ellipsoid to improve the high frequency model of the fuselage. It is very important to emphasize at this point that Option 4_4 should not be confused with Option 4_1 where fins, wings, rotor blades, etc. are also modelled by flat plates. In other words, Option 4_4 generates plates to improve the high frequency model of only the fuselage.

Before calculating the field patterns with the UTD code, the aircraft body, the ellipsoid, and any plates created by Option 4_4 can be visually inspected for correctness with Option 4_5. This option will then display the body in a pseudo-translucent manner with the composite ellipsoid calculated in Option 4_3 superimposed over the body in its proper position and the plates created by Option 4_4. At the present time, the plates generated by Option 4_1 can not be used in the NEWAIR code; however, work is in progress to add that capability to the HARP code.

Option 4_6 provides the user with a graphical method of entering a "tower" antenna that can be used with the MM code.

2.5 [5] Calculate Radiated Fields

Having selected the method for calculating the field patterns and completed the appropriate operations in Menu [4], the user can now calculate the field patterns. There are three options in Menu [5]. The first two have to do with the MM and the third, UTD. Option 5_1 takes the geometry file created by Option 4_2 and computes and displays the geometry used *internally* by

CHAPTER 2. GETTING STARTED

AMC. It makes no electromagnetic calculations, but processes the *input* file generated by Option 4_2. This option takes very little computer time, and should virtually always be used to verify the geometry before committing to a full MM run with Option 5_2.

Option 5_2 is used to make the complete MM calculation of the field patterns. Because this option can take several hours to complete, it is started as a background job and the menu immediately returns to its normal state, ready for more user input. This does *not* mean that the field pattern calculation has been completed. As of this writing, there is no return signal to HARP when the job has been completed. How the user can tell when the field calculations have been completed will be discussed in Section 4.5.

Option 5_3 is used to make the UTD field calculations. Unlike Option 5_2, the job is *not* launched in the background, since it typically takes far less computer time to complete than the MM calculations.

2.6 [6] Display Calculated Results

There are two options for viewing the results of the field calculations on the screen and two options for hardcopy output. To view the results in 3D on the screen, Option 6_1 is used to see the MM results and Option 6_2 is used to view the UTD results. If any attempt is made to view the results of the field calculations before they are completed, HARP will issue a warning and return to this menu. Similarly, for hard copy output Option 6_3 is for the MM results and Option 6_4 is for the UTD results.

2.7 [E] Exit HARP

Entering an **[E]** or **[e]** followed by hitting **[return]** from *any* menu will exit that menu. From the HARP Main Menu, HARP, itself, will be exited.

Part II
HARP: In Depth

Chapter 3

[1] Geometry Entry Menu

In order for HARP to calculate a radiation pattern for a particular aircraft, all relevant data needed for the calculation must first have been entered into a HARP database. For accurate results, perhaps the single most important operation is the accurate entering of the 2D cross-sections used to create the 3D model of the fuselage of the aircraft to be studied. From this menu, aircraft fuselage cross-sections along the length of the aircraft are entered, and *master* files which contain lists of these cross-sections and where they are to be used in the model are made. Following the creation of these master files the 2D silhouettes of the models can be viewed and 3D models can be created and viewed from other menus.

3.1 1_1 Enter Body Cross-sections

HARP builds the 3D physical model of an aircraft fuselage by lofting between representative cross-sections along the length of its body. These cross-sections must be entered by the user either from a blueprint or other engineering drawing using the Tektronix 4957 digitizing tablet. The coordinate system used by HARP and several of the cross-sections used in the example in Chapter 8 are shown in Figure 3.1. Note that the aircraft is essentially flying in the the -y direction with its nose near the origin and its fuselage extending out the +y axis. The xy plane is the horizontal or azimuth plane and the z axis points toward the top of the aircraft.

When Option 1_1 is first invoked, if the *current family name* and *pre-*

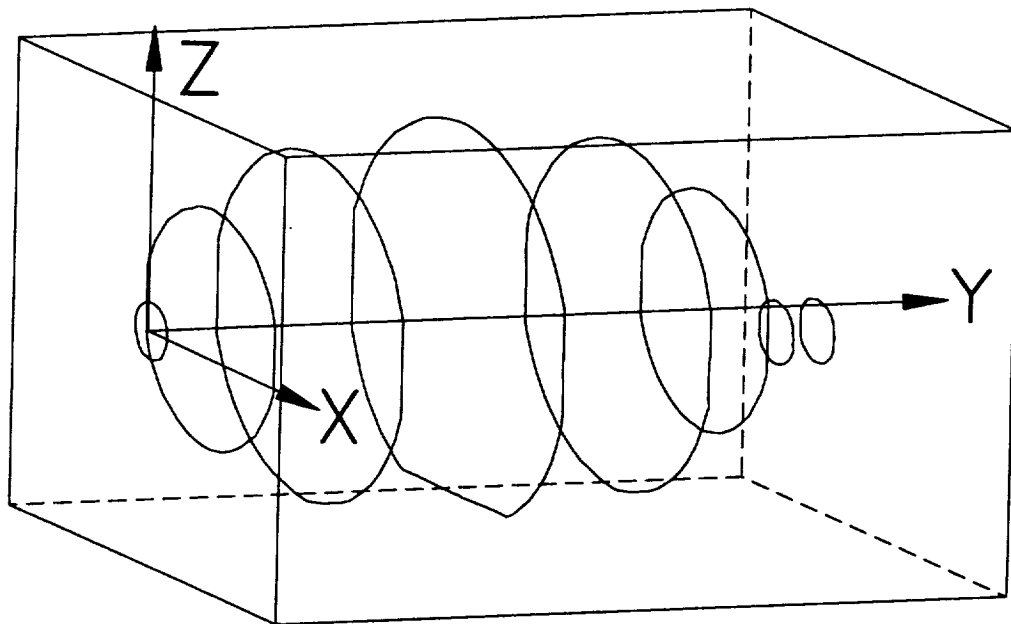

Figure 3.1: This is the coordinate system used by HARP. Several example cross-sections are shown. Note that the nose of the aircraft points toward the origin of this coordinate system and that the body lies along the y-axis.

CHAPTER 3. [1] GEOMETRY ENTRY MENU

ferred user units have not yet been specified, the user will be asked to supply this information before going on. See Sections 4.1 and 4.2 for a complete description on ways to specify these units.

The first step in creating an aircraft model with the HARP system involves the selection and entering of representative cross-sections of the fuselage of the aircraft to be modeled. These cross-sections should be selected in such a way that there are more cross-sections entered in areas of the aircraft body where there are the greatest changes in its geometry and relatively fewer in areas where there is little change in its geometry. By selecting cross-sections in this way the model that is generated from these cross-sections will most closely conform to the geometry of the actual aircraft. The process of entering these cross-sections begins by invoking Option 1_1 where the following questions and requests for action are made:

⇒ Now enter the model description line.

At this point, type a line describing the location of the cross-section to serve as a reminder where on the aircraft body it is located or some other relevant information. This feature is solely for the convenience of the user and is not used internally by HARP. If no description is desired, simply hit .

⇒ Enter the cross-section file number (extension) ...

In response to this request the user should enter a number like (which uniquely describes the cross-section to be entered) and hit . Every cross-section file has a *family name* like "lh" and an extension number from 000 through 999. Thus, there is a limit of one thousand *active* cross-section files for any aircraft. While there can be up to a thousand cross-section files, all these files need not be *active* at one time to make up the aircraft model. See Section 3.2. In practice fifteen to twenty cross-sections may be enough for an accurate model. Cross-section file extensions usually start at 0 or 1 and increase for those farther out on the y-axis along the aircraft body. This is not a requirement, however. These extension numbers may be in any desired order or no order at all. Similarly, there is no restriction on the order that the cross-section files need to be entered. The user may find it useful, however, when entering cross-sections, to leave a few unused extension numbers between adjacent cross-sections so that new cross-sections can be conveniently

CHAPTER 3. [1] GEOMETRY ENTRY MENU

added later between the old ones. The sole advantage of this is that files with higher extension numbers will always be farther out toward the tail of the aircraft. In practice, this is less confusing to the user, but it makes no difference whatsoever to HARP. When specifying extension numbers it is not necessary to enter any leading zeros.

⇒ Enter the y-station location for cross-section 102 in meters:

In this case, 102 is the current extension number. Enter the y coordinate where the new cross-section is located and hit . Remember that each cross-section lies completely in an xz-plane so to specify the (x,y,z) coordinates of the points that make up the cross-sections in 3D, the y-axis coordinate must be specified. Figure 3.1 shows the HARP coordinate system and representative cross-sections. If the *preferred* units are other than meters, HARP will ask for the y coordinate to be input in those units instead of meters. See the section on Option 4_2 for a complete description of *preferred* units.

⇒ Is this a symmetric cross-section [Y] ?

If the aircraft to be modeled is identical on the port and starboard sides (symmetric about the yz plane) at the location for which a cross-section is to be entered, this symmetry can be exploited. In this case the user can enter the half cross-section $x \geq 0$ and it will be mirrored to the other half-plane to complete the entire cross-section. If the two sides of the aircraft are not identical at the location of interest, the user should type . In this case the user must enter the entire cross-section.

⇒ Enter two points to use as a known distance on the tablet.

At this point the user would position the drawing or blueprint of the cross-section of interest on the Tektronix 4957 tablet and secure it with masking tape. Next, two points on the drawing that are a known distance apart would be selected and entered by depressing the YELLOW button on the digitizing puck when the crosshairs were aligned over these points. This sets the scale of the drawing so that distances entered on the tablet are automatically entered into the HARP database files with the proper magnitude. Choosing

CHAPTER 3. [1] GEOMETRY ENTRY MENU

the maximum extents of a cross-section along the z-axis is often a convenient choice for these points.

⇒ Enter this distance in meters:

The distance requested here is the known full scale distance between the two points just entered on the tablet. If the preferred units are centimeters, feet, or inches, this distance will be requested in those units instead of meters. Note that this distance is the scaled distance in drawing units, and *not* the tablet distance between these points. For example, if the distance between the selected points is 1.3 meters on the full size aircraft, then the user would enter and hit . An example cross-section is shown in Figure 3.2.

⇒ Enter the cross-section origin on the tablet.

For the typical cross-section shown in Figure 3.2, the origin would be entered by positioning the crosshairs of the puck over the origin location and depressing the YELLOW button on the puck. In Figure 3.2 this is the point marked *Cross-section Origin*. This point must be consistently chosen because *all* the cross-sections that make up the body must share this common point in the xz-plane. In other words if all the cross-sections were placed on the same xz-plane, they would share the same coordinate system and origin. The coordinate origin may be internal or external to a given cross section.

⇒ Enter any reference point on the positive (up) z-axis.

In Figure 3.2 this is the point marked *Up Vector Point*. This point is entered by lining up the puck and depressing the YELLOW button. These actions specify the coordinate axes on the tablet. This information, coupled with the known distance entered previously between the two reference points, provides all the information necessary to build the transformation matrix that is used to convert the tablet coordinates created when the YELLOW button on the puck is depressed to the real world coordinates used by HARP.

⇒ Enter the half cross-section now, starting on the + z-axis,

⇒ Progressing clock-wise, stopping on the - z-axis,

⇒ enter 6 to 50 POINTS. Use BLUE to enter the last point.

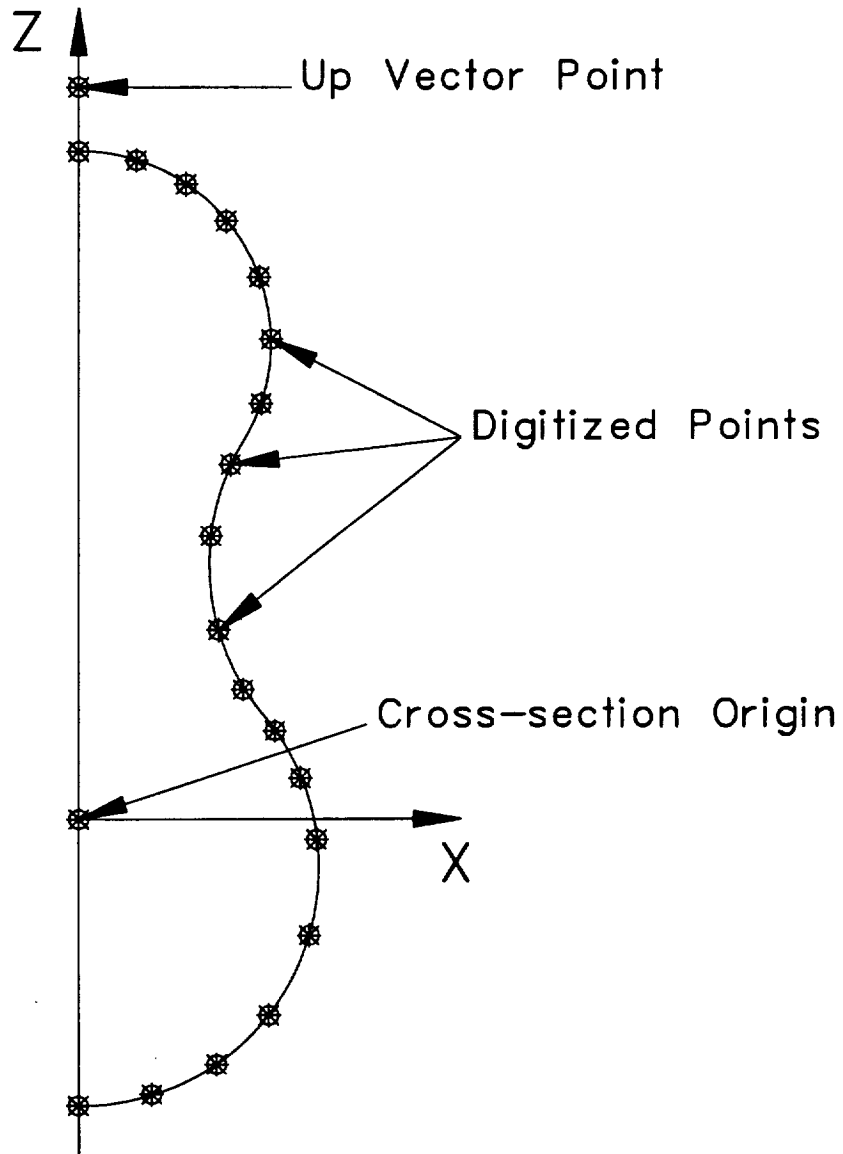

Figure 3.2: This is a typical cross-section showing the origin, up vector point, and possible points that could be digitized.

CHAPTER 3. [1] GEOMETRY ENTRY MENU

⇒(Use GREEN to delete previously entered points.)

The *complete* cross-section can now be entered by digitizing the points in the right *xz*-half-plane as shown in Figure 3.2. Points are entered by pushing the YELLOW button on the digitizing puck. Refer to Figure 3.2 again. The user would start with the point on the *z*-axis just below the *Up Vector Point* and proceed clockwise around the cross-section, ending on the *z*-axis by depressing the BLUE button for the last point. Cross-section points are always entered in this way. The first point digitized must *always* be highest point on the *z*-axis. Points must then be entered in a consecutive, clockwise fashion until the last point is reached, again, on the *z*-axis. The last point must *always* be located on the *z*-axis, and it must *always* be entered with the BLUE button on the puck. The above constraints are required only for cross-sections specified as being symmetric. For non-symmetric cross sections, one need not start and end on the *z*-axis. Depressing the BLUE button signals HARP that the last point to be digitized has been entered. No more than fifty points can be entered in total for a symmetric cross-section, and no more than one hundred points can be entered for a non-symmetric one. After the last point is entered, all the points are then splined in a special way and reflected to the negative half-plane so the complete cross-section can be displayed. If an error has been made entering a point, immediately pushing the GREEN button will delete this point. Repeatedly pushing the GREEN button will delete entered points back through the list in the reverse order that they were entered. After the cross-section is displayed it is not possible to correct a cross-section if it is not accurate. In this case, simply enter a new cross-section. When asked for the extension number, enter the same extension number as that of the file that must be redone. The old file will be overwritten.

⇒Do you wish to enter another cross-section [Y]

To create a new cross-section simply hit which is the default response or type a or then hit . Any other response will be interpreted as a *no* and the code will exit this option.

3.2 1_2 Build / Modify Master File

After at least two cross-sections have been entered, and before the aircraft body can be viewed, the master file *must* be created. This file contains the total number of *active* cross-sections, their y coordinate locations, and a list of the files that contain the cross-section data. It is this master file that provides HARP with the list of cross-section files to read and where to use this data in building the model of the fuselage of the aircraft. There are eight possible operations accessible from Option 1_2 concerning the making or modification of the master file and the cross-section files.

The eight operations are all listed when Option 1_2 is first invoked and whenever any of these operations has been completed. Each can be invoked in any desired order, but the user must be aware of the interactions among these operations so that the desired results are obtained. Unless expert mode (see Section 4.1) is active, *all* operations are automatically performed using the current family name. Each option is selected by entering its first letter and then hitting `return`. Invoking Option 1_2 lists these choices:

⇒l-ist, b-uild, c-opy, y-location, i-nfo, n-ame, d-elete, r-edraw, e-xit:
⇒Enter your choice now [L-ist]: `return`

l-ist: The default operation is *l-ist*. It looks up the current family name and finds all the cross-section files which exist in the *present working directory* with that family name. It then reports how many cross-section files were found and lists on the screen the files found along with their information fields and y-locations. No files are written and this operation does not interact with any other operation. It is informational only. The * at the far left of some cross-section file names indicates that the *'d file is included in the current *master* file. Hitting `return` or `l return` invokes this operation.

b-uild: The *b-uild* operation actually creates the master file for the current family name. It first lists the number of cross-section files and then asks if any of these files should be excluded from the master file. If it is desired to exclude any files, simply respond with a `Y` or `y` and provide the appropriate file's extension number. HARP will then ask if there are any other files to be excluded. If there are no more files to exclude, hit `return` to

CHAPTER 3. [1] GEOMETRY ENTRY MENU

automatically accept the "N" response. Note that excluding cross-section files from the master file *does not delete* any files. Excluded files are just not used to form the model of the fuselage of the aircraft. Also note that each time a new master file is built, *all* available cross-sections are automatically included. In other words, previously excluded files are re-included and must again be excluded if that is the desired operation. Typing invokes this operation.

c-copy: The *c-copy* operation allows the creation of new cross-section files, which are identical to previously entered ones, except that they are at a new y coordinate value along the aircraft body. With many aircraft there are long stretches along the fuselage that share the same cross-section shape. The user can employ Option 1_1 to reenter the same cross-section at different y values any number of times, but using the *c-copy* operation is the preferred method for creating these additional cross-sections. This method is quicker and more accurate, and tends to result in better models. Typing and hitting yields the following dialog for copying the cross-section file with extension 23 to a new file with extension 25:

⇒ What is the extension number of the cross-section file
⇒ that you want to copy? [none]:

⇒ What is the extension number of the new cross-section
⇒ file that you want to create? [none]:

⇒ The current preferred distance unit: meters
⇒ The original y value : 4.561
⇒ Enter new y value :

Note that this option does not move the cross-section from $y = 4.561$ meters to $y = 5.353$ meters, but rather creates a new cross-section at $y = 5.353$ meters.

y-location: If the y location of any of the cross-sections was entered incorrectly, this value can be changed by invoking *y-location*. The file extension number is requested and then the old y value is displayed in the user's preferred units along with a request for the new value in those same units. If no

CHAPTER 3. [1] GEOMETRY ENTRY MENU

change is desired, simply hit `return`. Typing `y` and hitting `return` would yield the following dialog to change the y value in the new cross-section file just created with *c-copy*:

```
⇒ What is the extension number of the cross-section file
⇒ that you want to change [none]? 25
⇒ Old y-location in meters: 5.353
⇒ New y-location in meters: 5.777
```

Note that this operation *only* updates the cross-section file. It does *not* automatically update the *master* file. **Warning!** For changes made by *y-location* to be incorporated into the model, the cross-section file must be *active* and the *b-wild* operation must be re-run to update the *master* file.

i-nfo: The information string included in each cross-section file can be edited using the *i-nfo* option. This information is only used to as a convenience to the user to help identify the location of the cross-section. This string is limited to 30 characters. Typing `i` and hitting `return` would result in the following dialog to change the information field in cross-section file 25:

```
⇒ What is the extension number of the cross-section file
⇒ that you want to change [none]? 25
⇒ Old string: Copied from esl.023
⇒ New string: Some new description here
```

Note that when a new cross-section file is created from a previously existing one using *c-copy*, the information string automatically lists the original source file. Thus, if the file *esl.025* were created from the file *esl.023*, the information field of *esl.025* would state that it was **Copied from esl.023**. The information string in any cross-section file can always be changed using *i-nfo*. Because this 30 character string is not used for any other purpose by the HARP system, the *master* file need not be updated.

n-ame: HARP also allows the renaming of any files for which the user has proper write access. This can be done with the *n-ame* option. This option does not list any files and if the file specified does not exist, no action is taken.

CHAPTER 3. [1] GEOMETRY ENTRY MENU

The user is then returned to the *build master* menu. If the file does exist, the user is prompted for the new name. Before the file is actually renamed, the user is asked to confirm the change from the old name to the new name. Typing would result in a dialog like the following:

⇒ File to rename [none]:

⇒ New file name:

⇒ Rename some-old-file as some-new-name ? [y]

By hitting the file *some-old-file* is renamed as *some-new-name*.

d-etele: HARP allows the user to delete cross-section files by using the *d-etele* option. The user is asked for the extension number of the cross-section file to be deleted. If the file exists, the file is deleted without conformation. If the file does not exist, no action is taken. Typing and hitting would initiate a dialog like the following:

⇒ What is the extension number of the cross-section file

⇒ that you want to delete [none]?

In this case the file *esl.025* would be deleted assuming that "esl" was the family name. The *d-etele* operation is *not* intended as a general purpose way to delete unwanted files. The intended purpose is solely to provided a mechanism to eliminate unwanted cross-section files conveniently from within HARP. The elimination of other unwanted files is best handled from the user's shell.

r-edraw: Any of the cross-section files that exist, regardless of whether they are part of a master file or not, can be be redrawn on the screen in 2D with the *r-edraw* option. The spline curve that HARP will use in the *xz*-plane at the *y* location of the cross-section is shown in GREEN. The data points that were entered on the tablet are shown in RED. The *xz*-axis for the cross-section is shown in BLUE. The *r-edraw* is useful for reviewing cross-section files when building the aircraft models. Typing and hitting would initiate a dialog like the following:

CHAPTER 3. [1] GEOMETRY ENTRY MENU

⇒What is the extension number of the cross-section file
⇒that you want to redraw [none]?

In this case the cross-section file *esl.006* would be drawn on the screen. This is, of course, assuming that the family name was "esl" and the file did, in fact, exist. Otherwise the program would exit with a message that the file *esl.006* did not exist.

e-xit: To exit from Option 1_2 use the *e-xit* option. Remember that a master file must be written before HARP can generate any 2D or 3D graphics or perform any antenna calculations. Typing and hitting will exit Option 1_2.

3.3 1_3 View Default Body Silhouette

After a master file has been created, even if all cross sections have not been entered, the overall appearance of the aircraft fuselage can be quickly checked by viewing the top and side silhouettes of the body by selecting Option 1_3. These 2D views are actually silhouettes in the sense that the maximum extents in each of the active cross-section files are selected and marked in RED. Note that the GREEN outline of the aircraft is composed of *linear* line segments between these points and *not* the splined curve HARP will use between the cross-sections in the 3D body. The silhouettes shown are in the correct scale of length to width so the overall appearance of the aircraft should match that of the actual aircraft being modeled.

3.4 1_4 Interpolate Cross-section

At times it may be desirable to create a new cross-section that is linearly interpolated or even extrapolated from two existing cross-section files. This situation could occur when cross-section drawings were not readily available for a particular location from a blueprint, but were clearly interpolations or extrapolations from other provided cross-section drawings. At other times it may be desirable to create a hybrid model of an aircraft that is actually a blending of two or more other models. In this situation, a better transition

CHAPTER 3. [1] GEOMETRY ENTRY MENU

can be made by creating new interpolated cross-section files. A typical dialog the user would expect from invoking this Option follows:

⇒ First cross-section file [none]:

⇒ Second cross-section file:

⇒ New cross-section file:

⇒ The current preferred distance unit: meters

⇒ lh.014 y value: 36.00000

⇒ lh.015 y value: 50.00000

⇒ lh.077 y value:

⇒ File lh.077 has been created.

Warning! If the y value specified does not lie between the two original cross-sections the new *extrapolated* cross-section should be checked with the *r-edraw* operation in Option 1_2 because this operation may generate a fuselage that contains loops.

Chapter 4

[3] Utility Menu

Options in the Defaults Menu allow the user to set a new family name or to check the present default family name. The user preferred units of length are also set here. It is sometimes desirable to be able to *temporarily* leave HARP to tend to other business without exiting the HARP system. This is also possible from this menu. Other options in this menu allow the user to submit a bug reports, predict completion times for MM calculations, and archive HARP data files.

4.1 3_1 Inquire/Set Family Name

When Option 3_1 is invoked the current family name is displayed, if one has already been declared in the present working directory (*pwd*). If this family name is the one desired, simply hit `return`. To change to a new family name, type `n` or `N` then `return`. HARP will then ask for the new family name. After entering the new name the user must then decide if HARP *expert* or *novice* mode should be set. This mode significantly affects the power and flexibility of the HARP system. An infrequent, new, or casual user working in a single directory with a single family name, should select the *novice* mode. This may speed up work by assuming the same family name for all operations. However, the *expert* mode allows the user to mix and match the various files from other family names to form composite models. This increased flexibility can be extremely useful and time saving. In response to the mode question, enter a `0` for novice mode or a `1` for expert mode.

CHAPTER 4. [3] UTILITY MENU

The novice mode is the default mode and can be selected by simply hitting `return`. Any time a new family name is selected Option 3_2 is also automatically invoked to set the user's preferred units for length. See Section 4.2 for details. Assuming that the family name "esl" has already been set in the *pwd* and that it is desired to change the family name to "f18" and to then work with units of feet, the following dialog would result upon invoking Option 3_1:

⇒ The current family name: esl Ok? [Y]

⇒ Please enter the new default family name:

⇒ The level of family file name confirmation used in HARP
⇒ can now be set. The flexibility of the HARP system is
⇒ affected by the level set. Please take note!

⇒ Enter a 1 for Expert level with maximum confirmation
⇒ or a 0 for Novice level with minimum confirmation [0]:

⇒ **Default Units**

⇒ < 1 > You want to work in meters.
⇒ < 2 > You want to work in centimeters.
⇒ < 3 > You want to work in feet.
⇒ < 4 > You want to work in inches.

⇒ Enter option...[1]:

If no previous family name had been set, this dialog would have been the same starting with the request for the new default family name.

4.2 3_2 Set User Preferred Units

There are various times the user must specify distances when creating the HARP database files for an aircraft. The default unit for distance can be specified as meters, centimeters, feet, or inches. Option 3_2 is used to set these default units. After these units are set, HARP automatically requests

CHAPTER 4. [3] UTILITY MENU

user input in the selected units whenever a distance must be specified. HARP then converts the input to meters for all *internal* storage and calculations. All distances *internal* to HARP are in meters. The conversion to meters if the user has specified some other distance units is taken care of automatically so the user need not be concerned about it. These preferred units can be changed at any time. This includes at any time in the middle of building an aircraft model. To work in *inches*, Option 3_2 would be invoked and the follow dialog would result:

⇒ **Default Units**

⇒< 1 > You want to work in meters.

⇒< 2 > You want to work in centimeters.

⇒< 3 > You want to work in feet.

⇒< 4 > You want to work in inches.

⇒ Enter option...[1]:

From this point on, until a new preferred unit for distance is specified, HARP would request all distances needed in inches.

4.3 3_3 Exit HARP to Your Shell

Option 3_3 is intended to allow a *temporary* exit to the user's default shell. This is especially useful when HARP is used in the full TekScreen mode where there is no other access to the operating system. To resume HARP operations when finished, type then hit .

4.4 3_4 Submit Bug Report

Sometimes the user may discover a problem with some aspect of HARP in the process of using it. If after reading this manual carefully the desired results cannot be obtained or if the user is convinced that a "bug" has been found, this option will allow a bug report to automatically be sent by email to the ElectroScience Lab at The Ohio State University where HARP is currently

CHAPTER 4. [3] UTILITY MENU

being upgraded and improved. HARP is a complex, tightly related group of programs. Consequently, it is very important that any submitted bug report be as specific and documented as possible. Re-creating bugs from good user reports is often the best way to ferret them out. Invoking Option 3_4 would yield a dialog like following:

⇒ Enter your bug report, and end with <CTRL>-D:

Type a clear report here including as much relevant information as possible. Then then press the "Ctrl" and "D" keys simultaneously to end the report.
^D

This report will then be emailed to The Ohio State University ElectroScience Lab.

4.5 3_5 Predict MM Completion

When Option 5_2 is used to predict the electromagnetic field patterns for an aircraft using the method of moment, the calculations can take minutes or hours to complete. To predict when these calculations are likely to be completed, Option 3_5 is used. The prediction is made by extrapolating the least squares fit to data in the status file written by the moment method code as it makes its calculations. Invoking Option 3_5 would cause something like the following to be printed to the screen:

⇒ Matrix filled in approx. 27 minutes, 51 seconds,
⇒ or at Fri Aug 7 14:59:54 PM.
⇒ Code began Fri Aug 7 14:28:39 PM,
⇒ and has used 3 minutes, 24 seconds.

Option 3_5 can be invoked at any time even if the moment method code is not running. If the calculations have been completed the screen output will be the following:

⇒ Run is complete.

CHAPTER 4. [3] UTILITY MENU

If an error has occurred anytime during the run the following would be printed:

- ⇒ Errors occurred, listed in file `esl.amc_errors`
- ⇒ Aborting...

In this case it is assumed that “`esl`” is the current family name. Clues to the problem the moment code may have encountered can often be found in the `amc_errors` file which can be viewed with any editor or presented on the screen with `cat` or `pg`.

4.6 3_6 Archive/Recover Data

HARP creates a large number of data files. Many of these files change as the various HARP options are exercised. This constant changing of the HARP data files can make it difficult if not practically impossible to reproduce previous work. Option 3_6 has been provided to save *all* the files with the *current family name* (CFN) to an archive. By using this Option, a “snap shot” of the user’s present work can be saved in a compressed `cpio` file for later retrieval.

⇒ Archive Control Menu

- ⇒ `h-elp`, `c-reate`, `d-elete`, `l-ist`, `t-able`, `x-tract`, `e-xit`:
- ⇒ Enter your choice [`h-elp`]: `return`

h-elp: The default operation is `h-elp`. Hitting `return` or `h`, `H` or any other character not tied to the menu functions, followed by `return` will bring up the following menu:

- ⇒ `h-elp` display this message.
- ⇒ `c-reate` create an archive of current data.
- ⇒ `d-elete` delete an archive and/or files from one.
- ⇒ `l-ist` list the available archives.
- ⇒ `t-able` list the files in an archive.
- ⇒ `x-tract` extract files from an archive.

CHAPTER 4. [3] UTILITY MENU

⇒ Upper or lower case letters may be used to denote option.

⇒ Hit RETURN to continue.....

c-reate: The *c-reate* operation is used to create a new archive that will include all the files in the *present working directory (pwd)* with the *current family name*. For instance, if the current family name were *rah* then all the files that matched "*rah.**" would be picked up and placed in a compressed file. Before HARP can create the archive file, however, a "tag" to further identify it must be supplied by the user. This tag is restricted to characters and/or numbers in any desired order, but must not be longer than 126 alphanumeric characters in total. HARP takes the family name, appends this tag to it, and then appends ".*archive.Z*" to the end of this combination to arrive at the archive name. If an archive file already exists with this name, HARP will report this fact, and prevent any possibility of a duplicate archive name being created in the *same* directory. By typing `c return`, an archive would be created like this:

⇒ Current family name is rah.

⇒ Enter archive tag (126 chars max): `384b`

⇒ Created archive: rah384b.archive.Z

⇒ Hit RETURN to continue.

d-elete: The *d-elete* operation is used to delete any old archives that are no longer needed or to delete files that were extracted from an archive. See the section on *x-tract*. To delete an archive or its files, type `d return`:

⇒ Number of archives: 3

⇒ #	Name	Size	Created
⇒ 0	rahtestA1.archive.Z	50979	Tue Aug 4 18:50:54 1992
⇒ 1	lh121.archive.Z	50985	Wed Sep 2 17:36:54 1992
⇒ 2	esl044.archive.Z	51009	Wed Sep 2 17:56:55 1992

CHAPTER 4. [3] UTILITY MENU

⇒ Enter the archive number to delete:

⇒ Delete the files from lh121.archive.Z [n] ?

⇒ 32 files deleted.

⇒ Delete the archive lh121.archive.Z [n] ?

⇒ Delete any more files? [n]

⇒ Hit RETURN to continue.

In this case the archiver found no files from *lh121.archive.Z*, and reported this to the user. Had there been any files to delete, the archiver would have reported the number of files it deleted. There has been no provision made to delete *individual* files that were once part of an archive.

l-ist: The *l-ist* operation lists the archive files found in the *present working directory* in exactly the same manner as previously shown for the *d-elete* operation.

t-able: The *t-able* operation lists archive files found in the *present working directory* in exactly the same way as the *d-elete* and *l-ist* operations. A table of all the files contained in the selected archive is then presented on the screen. After listing the archives, HARP requests the number of the archive for which it should list the files. This number is listed on the far left of the screen under the # sign:

⇒ Archive number to table? [0]

Simply hitting would table the zeroth archive, would table the next, and so on.

x-tract: The *x-tract* operation is used to recover the files stored in an archive. Like the other archive operations, this one lists the archive files found. It then asks:

CHAPTER 4. [3] UTILITY MENU

⇒ Enter archive number to extract:

After writing the files, HARP then offers the opportunity to change the *current family name* (CFN) to this archive name:

⇒ Change the CFN to esl044? [y]

Here “esl044” is the part of the archive name before the “.archive.Z” part of the complete archive name.

e-xit: When finished with the operations provided in the **Archive Control Menu**, simply type or .

4.7 3_7 Write Status File to Disk

Option 3_7 is for conveniently extracting data from the various HARP database files and writing a summary page of this data to disk.

⇒ **Status Page**

⇒ Choose t-erse, v-erbose [t]:

At this point the user can decide if a **terse** summary consisting of only the major data will be written to disk or a far more **verbose** summary should be written. All user input other than or are defaulted to *terse*.

⇒ Output desired: m-MM, u-UTD, b-oth, n-one [b]:

⇒ Enter an if only MM data files are of interest, if only the UTD data should be summarized, for both types of data, and if only data concerning the fuselage, fins, antenna, and rotor are of interest. Unexpected user inputs are defaulted to .

⇒ Output file: rah.status OK? [y]:

CHAPTER 4. [3] UTILITY MENU

All user input other than n or N is defaulted to y.

⇒ Enter output file name:

In this case the file *mm-summary* would be written to disk. If no file name is provided, the output summary is echoed to the screen.

4.8 3_8 Set Temporary AMC Defaults

Option 3_8 is used to write a temporary file that modifies the default settings for AMC when Option 5_2 is invoked. Specifically, it sets the values of the AMC *WR* and/or *IN* commands. [1] The menu structure for this option looks like the following:

⇒ **AMC Temporary Defaults Menu**

- ⇒ < 1 > Print the detailed description of the wire and plate geometry. This includes the coordinates of every plate and wire segment and the description of the MM modes.
- ⇒ < 2 > Write the current vector plus the wire and modal geometry to the output file.
- ⇒ < 3 > Write the impedance matrix to the output file.
⇒ Caution: This results in N*N lines of output where N is the total number of MM modes.
- ⇒ < 4 > Change the number of Simpson's rule integration intervals used for the wire-to-wire impedances.
- ⇒ < 5 > Change the number of Simpson's rule integration intervals used in integrating over the surface patch monopoles.

⇒ Enter your choice(s) [exit]:

A running *summary* of the settings is displayed at the bottom of the page. To *exit* Option 3_8, simply hit when the desired options have been set. Note that the first three items are *toggled* between write and not set each time they are selected. In a similar fashion, items four and five can

CHAPTER 4. [3] UTILITY MENU

set as many times as desired. Only those values set at exit are kept. The summary line would look like the following:

⇒New Settings: < 1 >= write < 2 >= not set < 3 >= not set < 4 >= 4
< 5 >= 6

Caution should be used when setting these new defaults because very large files or long compute times can result. See the AMC manual for further details. [1]

Chapter 5

[4] Model Comparison Menu

The Model Comparison Menu is arguably the most important menu of the HARP system. It is certainly the most used. This menu allows the user to view the aircraft models created from the cross-section files in 3D. From this menu antennas, fins, and rotor blades are created and/or specified for the “physical” model of the aircraft. The MM and UTD models can then be created and displayed in this menu by operations on this physical model. In addition to being able to view input and output models of the MM code and the input models of the UTD code, additional calculations are automatically made to generate data files that will serve as the input to the electromagnetic codes. This is one of the great strengths of HARP. It is important, however, to visually verify the quality and accuracy of these models before committing to a complete electromagnetic calculation which could take anywhere from a few minutes to several hours. Fortunately, another great strength of HARP is the ability to quickly and accurately view all aspects and all angles of the models with the powerful 3D graphics system.

5.1 4_1 Add/Display Physical Features

The basic physical body of the aircraft is created using Option 1_2 in Menu [1] described in Chapter 3. To this body there are three features that can be added to complete the model. The first of these features concerns fins. As stated before, fin here is a general term to describe wings, horizontal and vertical stabilizers, and other aircraft control surfaces. These fins are modeled

CHAPTER 5. [4] MODEL COMPARISON MENU

as planar quadrilateral plates that are then attached to the aircraft's physical body under software control directed by the user.

While HARP was initially conceived as a tool to predict radiation patterns for helicopters, it is in no way restricted to helicopters alone. It is fully capable of predicting the radiation patterns for *any* geometry consisting of a main body or fuselage with attached wings and fins. For helicopters, however, a feature of HARP is the ability to model the rotor hub and main rotor blades. There can be any desired number of blades placed at any angle of rotation relative to the positive x-axis of the HARP coordinate system. The entire rotor assembly can also be tilted fore or aft a number of degrees like helicopters in flight.

The key feature that needs to be added to the physical body before any radiation pattern can be calculated is the antenna. It is also necessary to have specified an antenna in Option 4_1 before any other option in Menu [4] can be invoked. In the present version of HARP, monopole antennas of arbitrary length, orientation, and location can be specified. Future versions of HARP are planned which can deal with other antenna types.

5.1.1 Fin Operations

After invoking Option 4_1 the first thing the user is presented with is the **Fin Control Menu**:

< 1 > Read in the fin family data file.

< 2 > Enter/edit fin data.

< 3 > Forget about fins for now.

If one types [1] followed by `return`, HARP will read in the fin data from the current family name fin file if there is one. If the fin file does not exist, HARP will return to the **Fin Control Menu** after a brief message indicating that the fin file does not exist. If one does not wish to enter new fins or to display the fins in the current fin file, one can simply type [3] and `return`. To enter new fins or to modify previously entered fins, type [2] and `return`.

Assuming a current family name of "lh" and that there is no fin file, the first thing the user would see upon selecting "2" would be the following:

CHAPTER 5. [4] MODEL COMPARISON MENU

⇒ File lh.fins does NOT exist.

⇒ Enter new fins now [Y] ?

If the response to this question is negative, HARP assumes that no fins are desired at this time and continues. If the response is positive the following will be seen:

⇒ On the tablet, enter two points a known distance apart.

This will set the scale of the drawing so that dimensions taken from the tablet will be correct. Any *known* distance on the drawing or blueprint will serve this purpose. This distance is marked by aligning the crosshairs on the digitizing puck at one known point and pressing the YELLOW button then moving to another known point and pressing the YELLOW button again. The user must then supply the full scale distance between these points in the set preferred units:

⇒ Enter this distance in meters:

Here it is assumed that the preferred units are meters. The next steps consist of marking the four corners of the fin in the proper order:

⇒ Enter the leading attachment point on the tablet.

⇒ Enter the trailing attachment point.

⇒ Enter the trailing unattached point and the leading unattached point.

Leading and trailing attachment points are the fore and aft corners of the fin which connect to the aircraft body. See Figure 5.1. The corners of the fin *must* be entered in the requested order for proper results. To enter a corner of the fin, place the crosshairs of the digitizing puck on that point and depress the YELLOW button.

⇒ Enter fin leading y value in meters:

This number is the y coordinate of the leading attached corner of the fin just entered. Like all other distances requested by HARP this value is requested in the user's preferred units.

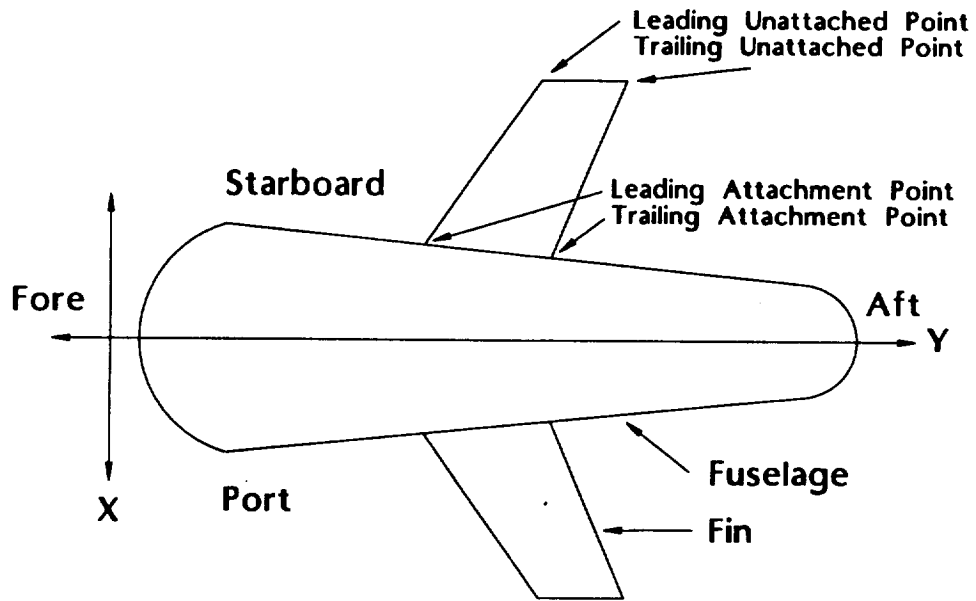

Figure 5.1: The attachment point specifications for the fins.

CHAPTER 5. [4] MODEL COMPARISON MENU

⇒ Fin attachment angle from +x-axis around body (degrees):

Picture a ring surrounding the aircraft not unlike the ring on your finger. This attachment angle is the connection point in degrees where the fin contacts the body of the aircraft. The starting point is the +x-axis which is directly to the aircraft's port side. The degrees then increase as we sweep along the ring directly overhead to 90 degrees. Continuing the swing directly to the starboard side we have 180 degrees. Directly beneath the aircraft we have 270 degrees and finally back to the port side we have 360 degrees. All angles requested by HARP should normally be supplied in the range of [0.0, 360.0] degrees, but negative angles are acceptable. This attachment angle is Ψ in Figure 5.2.

⇒ Fin inclination from +x-axis (degrees):

This second angle is shown as Ω in Figure 5.2. It determines the orientation of the fin. 90.0 degrees will orient the fin vertically straight up. 0.0 degrees will make the fin stick out to the port side parallel to the x-axis. A fin that is attached to the underside of the aircraft and is pointing straight down would be specified with an angle of 270 degrees. Any angle in the range of [0.0, 360.0] degrees is acceptable. The user, however, must be cognizant of the attachment point of the fin because it is possible to specify angles which would place the fin *inside* the aircraft. For instance, if the fin were attached on top the aircraft at 90.0 degrees, but the inclination angle were specified as 270.0 degrees, instead of sticking out from the aircraft, the fin would be inside the aircraft and may not be visible at all.

⇒ Enter the fin description tag now:

The tag is a string up to 50 characters long used to help the user identify what the fin is or where it is located. This tag can prove useful when editing the fin database.

⇒ Enter more fins [Y] ?

At this point if no more fins are to be entered, answer or and . If more fins are to be entered, simply hit and above cycle will repeat

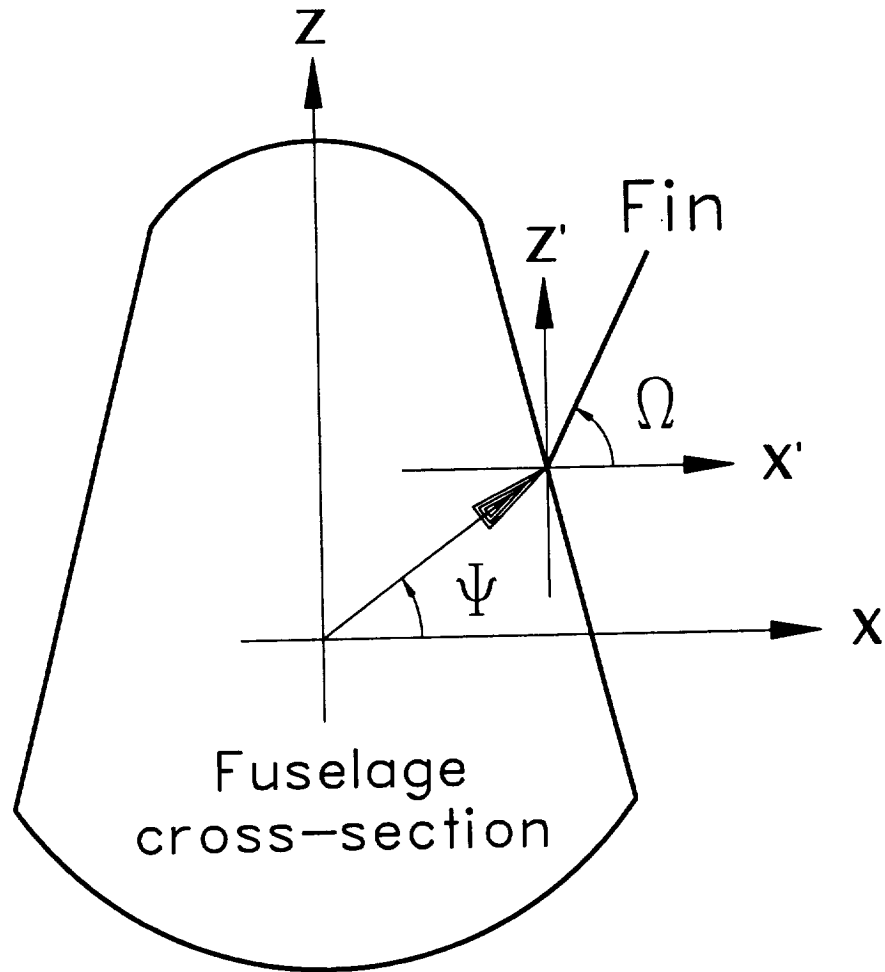

Figure 5.2: The angles used to specify attachment and inclination of fins.

CHAPTER 5. [4] MODEL COMPARISON MENU

itself.

If a fin file already exists when "2" is selected from the **Fin Control Menu** the following **Fin Editing Menu** is presented:

⇒ l-ist, d-elete, t-oggle, a-dd, m-irror, e-xit
⇒ Enter you choice now [L]:

l-ist: If the default is chosen by hitting or and , HARP will report the number of fins defined in the fin file and request again before reporting all relevant data on the fins defined. These data are listed in six columns for each fin defined. The first column, labeled "No.", lists the fin number. The second column, "Active", contains a "Y" or "N" indicating whether the indicated fin should or should not be included in the displayed graphics or electromagnetic calculations. The next column contains the "Y-coordinate" of the leading attachment point of the fin on the aircraft body. The "Roll angle" is next, and is identical to the angle Ψ in Figure 5.2. This is the fin attachment angle around the body in degrees from the +x-axis. The "Inclination" is listed in the next column and is the same as angle Ω in Figure 5.2. The entry in the last column is the "Description" string of the fin. This is the "tag" the user may have entered to describe the fin or its location.

d-elete: The *d-elete* option under the **Fin Editing Menu** is used to completely remove a fin entry in the fin data file. The number of the fin to be deleted will be requested. This number is the same as that listed in the first column when the *l-ist* option is invoked. Invoking the *l-ist* option after deleting a fin will cause a "D" to be displayed in the second column instead of the "Y" or "N" usually found there. This means that fin's data entries are marked for deletion. While there is no un-delete option, nothing is actually deleted until conformation of all changes is made during the *e-xit* from this menu.

t-oggle: The *t-oggle* option is used to toggle the specified fin to the active to the inactive state, or *visa versa*. All fins when first created are in the active state. Only *active* fins are displayed by the graphics system or are included in any field calculations. To determine if a fin is active or not see the second column of the output provided by the *l-ist* option. If a file is active a "Y"

CHAPTER 5. [4] MODEL COMPARISON MENU

will be shown in this column. An inactive fin will be shown by a "N" in this column. The advantage of this toggle function is that it allows the electromagnetic effects of certain fins to be tested or to refine fin shapes without losing previous work.

a-dd: The *a-dd* option allows a new fin to be added and is identical to that described at the beginning of Section 5.1.1. There can be an unlimited number of fins in the family fin files, but not more than 50 can ever be active at any time.

m-irror The port (+x axis) and starboard (-x axis) sides of an aircraft are usually but not always identical. For those aircraft bodies exhibiting structural symmetry, any fin that has been entered for either side of the aircraft can be mirrored to the other side without having to re-enter the data from the tablet. The *m-irror* option creates a new entry in the fin file for the specified fin. This is accomplished by changing the sign of the x coordinates of the fin vertices and recalculating the proper attachment and inclination angles. While HARP will allow fins completely in the yz-plane to be mirrored, this should never be done because it essentially means that there are two identical fins in the same location on the aircraft and this will lead to problems in the electromagnetic calculations. There is nothing to keep the user from mirroring fins on an aircraft body that does not exhibit symmetry, but this can cause distortions in the model and is *not* recommended.

e-xit No modifications of any kind are made to the *actual* fin file until confirmation is made to save these changes when the *e-xit* option is invoked:

⇒ Save your changes [Y] ?

Any response other than or or followed by will be interpreted as not wanting to save the changes and the fin file will be left unchanged.

At the present time, the UTD code does not use the plates generated with Option 4_1; however, this capability is currently being added to the HARP code.

CHAPTER 5. [4] MODEL COMPARISON MENU

5.1.2 Antenna Operations

After completing fin operations the user is presented with the **Antenna Menu**:

- < 1 > Use family antenna data file.
- < 2 > Pick a new antenna location.
- < 3 > Forget the antenna for now.

Entering a followed by a will cause HARP to read the family antenna data file. If no antenna file exists, HARP will present a brief message indicating that the file does not exist and then will return to the **Antenna Menu**. If the user does not want to choose and/or display the antenna then typing followed by the usual will skip over it. The graphics system will then display the physical model as usual, sans an antenna. Note, however, that an antenna *must* be chosen before any of the other graphical displays are possible or before any field calculations can be made. The present version of HARP allows only one antenna to be specified at a time for each family name.

Select to specify a new antenna. The following information will then need to be supplied:

⇒ Enter antenna y value in meters:

Here the user's preferred units are meters and the y coordinate of the base of the antenna is requested.

⇒ Attachment angle from + x-axis around body (degrees):

Specifying this angle is just like specifying the attachment angle for fins. In Figure 5.2 this angle is Ψ . The acceptable range is [0.0, 360.0] degrees.

⇒ Enter the antenna length in meters:

Again, the user's preferred units are meters. The antenna length must be specified in absolute distance and not in some relative distance like λ 's because the antenna length is fixed and no frequency of operation has yet been

CHAPTER 5. [4] MODEL COMPARISON MENU

specified.

⇒ Enter angle with + x-axis (phi):

This is the angle in degrees in the xy-plane starting on the + x-axis and moving counter-clockwise. It represents the angle the antenna is "pointing" in projected onto the xy-plane. The acceptable range for this angle is [0.0, 360.0] degrees. Most people trained in electrical engineering recognize this angle as ϕ .

⇒ Enter angle with + z-axis (theta):

This is the angle in degrees from the + z-axis that the antenna would make if its base were at the origin. The acceptable range for this angle is [0.0, 180.0] degrees. Most engineers recognize this angle as θ . The angles ϕ and θ are the normal coordinate angles used in 3D. They are shown in Figure 6.1. Note that in the UTD portion of this code, it is assumed that the monopole antenna is pointed in the direction normal to the surface. Thus, the angles with respect to the x- and z-axis will no be used when the NEWAIR code is run.

All the information necessary to specify the antenna has now been collected. It is necessary to save this information to a file to do any field calculations, however, it is not necessary to save the data to a file if only displaying the antenna is desired. Since the data will almost always want to be saved, the following question comes up with a default affirmative reply that can be accepted by hitting .

⇒ Do you want to save the antenna data to a file? [Y]

5.1.3 Rotor Assembly Operations

The rotor assembly of a helicopter is quite complex. HARP can model this assembly with any number of main rotor blades both graphically and electrically. After having specified the antenna, the user can now specify the number and shape of the main rotor blades from the **Rotor Blade Menu**:

CHAPTER 5. [4] MODEL COMPARISON MENU

- < 1 > Use family rotor blade file.
- < 2 > Enter new blades from the tablet.
- < 3 > Forget about rotor blades for now.

Like the other specification menus under Option 4_1, picks up the data from the family rotor file and simply skips over the need to specify a rotor, such as when the aircraft does not contain rotor blades.

To enter a new rotor geometry is typed. The following inputs must then be supplied:

⇒ On the tablet, enter two points a known distance apart.

Just as in Section 5.1.1 for specifying the scale for the fins, this now sets the drawing scale for the rotor blades.

⇒ Enter this distance in meters:

The user's preferred units are meters here but could just as easily have been inches, feet, or centimeters as set by Option 3_2. After this scale has been set the actual shape of the blade can be entered on the tablet.

⇒ Enter 4 or 6 points describing the blade, starting at the
⇒ rotor end, continue clockwise as viewed from the top,
⇒ and finish at the rotor end with the BLUE button.

If the blade is essentially straight or has a linear taper then 4 points can be used to describe the blade. If the blade has a raked end then 6 points must be used. All the points are digitized by lining up the crosshairs of the puck and pressing the YELLOW button except for the *last* point digitized. The last point must be digitized using the BLUE button on the puck. It is important the points digitized start at the rotor and proceed outward and move in a clockwise fashion, returning to the rotor end for the last point. After this geometry has been entered, additional information will be requested:

⇒ Enter the number of blades on the rotor:

CHAPTER 5. [4] MODEL COMPARISON MENU

HARP will accept any number of rotor blades in the range [1, 10].

⇒ Enter the y-location of the rotor in meters:

This is the y coordinate of the base of the rotor assembly requested in the user's preferred units.

⇒ Enter the phi location for the rotor in degrees:

This is the attachment angle from the + x-axis around the helicopter body. The angle requested here is the angle Φ in Figure 5.3. While no default angle is set, it is expected that the user will almost always choose 90 degrees because this angle places the rotor at the top of the aircraft. Any angle in the range [0.0, 360.0] degrees is acceptable. A more realistic range, however, is [80.0, 100.0] degrees. This can be used to slightly offset the rotor from the axis of symmetry of the helicopter.

⇒ Enter the height of the rotor in meters:

This is the vertical height of the rotor blades from the point of intersection of the surface of the helicopter and the vector from the origin of the xz-plane at the y-location, out through the body at an angle phi from the x-axis as specified above. In other words, this is the distance from normal plane at the base of the rotor assembly where the rotor attaches to the fuselage and the plane swept out by the rotor blades as shown in Figure 5.3.

⇒ Do you wish to save the blade data to a file? [Y]

Hit to take the default response to save the rotor data to the family rotor file.

5.2 4_2 Generate/Display MM Input Model

Option 4_2 is for generating the Method of Moments (MM) Aircraft Modeling Code (AMC) code input file, and for viewing the input model that HARP generates for it. The model is generated from the physical body built in

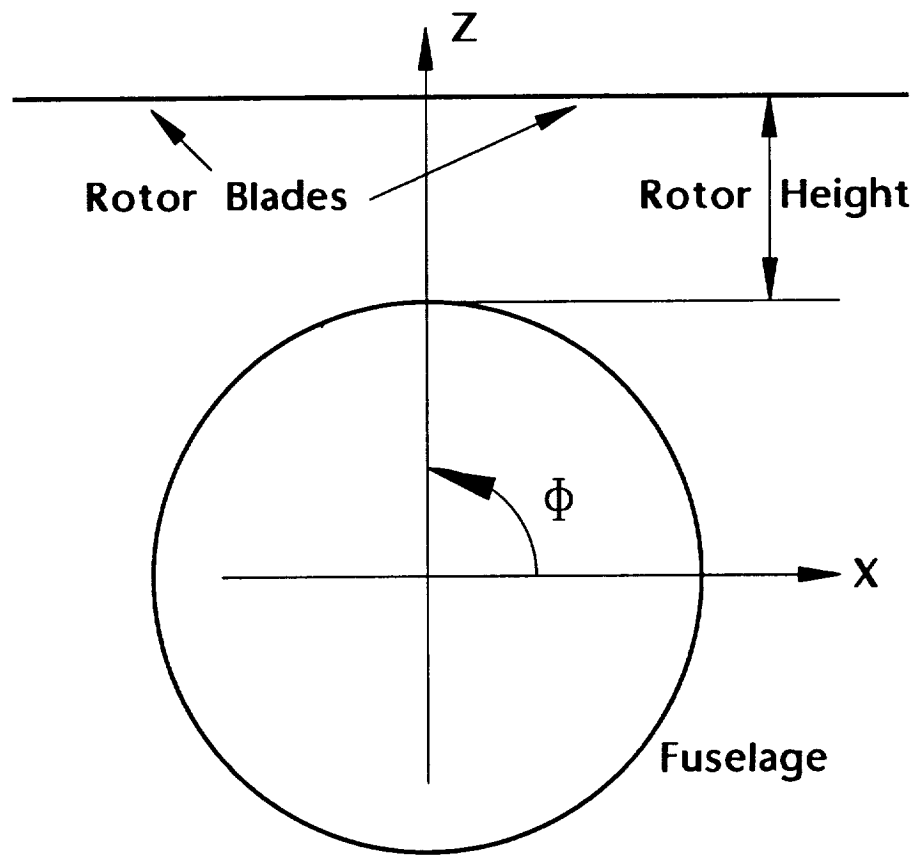

Figure 5.3: The angle and height specifications for the rotor assembly.

CHAPTER 5. [4] MODEL COMPARISON MENU

Option 1_2 and from additional features added in Option 4_1 as well as other specific information requested when this option is invoked.

Assuming a rotor file exists, two questions concerning the rotor are asked about its orientation:

⇒ Enter the desired angle of the first rotor blade
⇒ with the positive x-axis (in degrees) [0.0]:

This feature is for rotating the blades to any specific location in the 360 degree range so that the effect these rotor blades have on the field pattern can be ascertained. The default position has one of the blades oriented straight to port, parallel to the positive x-axis. The angle requested is that angle in degrees between a line parallel to the x-axis through the center of the rotor hub and this first blade. Positive as well as negative angles are acceptable. The default angle is 0.0 degrees and can be entered simply by hitting .

⇒ Enter the desired fore-aft rotor tilt (in degrees) [0.0]:

The entire rotor assembly and blades can be tilted forward or backward any number of positive or negative degrees to simulate their flight position. The angle requested is that angle in degrees between a line parallel to the z-axis through the base of the rotor assembly where it contacts the aircraft body and the axis of rotation of this rotor assembly. While there are no restrictions on the angles accepted, the most likely range will be [-10.0, 10.0] degrees. The default value of 0.0 degrees can be entered simply by hitting . **Warning!** It is very easy to specify too much tilt. In such a case the rotor blades which are modeled as wires in the MM code may actually make contact with the body or fins of the aircraft. If this occurs the results of the field calculations may not be accurate.

⇒ Enter 6 to 16 body sides [10]:

The MM model of an aircraft is essentially a structure composed of connected plates and wires. HARP takes the physical model and generates the equivalent plate model. If slices are cut through this model parallel to the xz-plane, these cross-sectional cuts are all irregular polygons of n sides throughout the length of the body where n is the number of sides requested. The acceptable

CHAPTER 5. [4] MODEL COMPARISON MENU

range for n is [6,16] and the default is 10 sides. Generally, the greater the number of sides, the greater the accuracy of the field results, and also the greater the required computer storage and CPU time. In all cases the number of sides must be equal to or greater than the number of *active fins* and less than or equal to 16.

⇒ Enter frequency (MHz):

The MM body created depends on the frequency at which the field calculations are to be made. Therefore, this frequency in Megahertz is the same at that which will be used to make the field calculations later with Option 5_2. For MM calculations this is the *sole* point at which the frequency can be specified.

⇒ Enter segmentation size in lambdas between cross-sections [0.2]:

The cross-sections HARP creates parallel to the xz -plane down the length of the body are spaced according to frequency. This spacing between cross-sections must be in the range > 0 to 0.25λ . Inputs outside this range are trapped and the user is requested to reenter a number within this range. The default value of 0.2λ is acceptable for most calculations. While additional accuracy may be obtained with a smaller fraction of a λ , computation time will increase dramatically. While HARP is calculating the model the following is displayed:

⇒ Making moment method model, please wait...

For improved accuracy of the calculated field patterns, an attachment mode can be specified. This attachment mode is a current disk at the base of the antenna that has a radius of typically 0.10 to 0.20λ . It's purpose is to enforce continuity of current at the antenna/fuselage junction. For the attachment mode to work properly the fuselage should be reasonably flat out to a radius of at least 0.1λ from the attachment point.

⇒ Enter the attachment radius in meters (0 = none) [2.4148]:

HARP calculates the maximum attachment mode radius based upon the size

and “flatness” of the fuselage at the attachment point. If this radius is between 0.1 and 0.2λ it is suggested that the user accept it by hitting `return`. If some other radius is desired, like 2.25 meters, simply enter `2.25 return`. If no attachment mode is desired, enter `0 return`. If the suggested radius is less than 0.1λ , the use of an attachment mode is not recommended. The attachment disk radius should never exceed 0.25λ . The user is cautioned that, in some (rare) cases, the use of an attachment mode appears to have made results worse, and thus it should be used with caution. A problem is indicated if the computed patterns change significantly as the attachment disk radius is changed.

5.3 4_3 Calculate UTD Ellipsoid

To make high frequency (i.e., when the size of the body is several λ or more) field calculations the Method of Moments becomes impractical because the time and computer resources needed to complete these calculations becomes too great. In the high frequency regime it is suggested that field calculations be made with the NEWAIR code, which is based upon the Uniform Theory of Diffraction (UTD). In the UTD branch of HARP, the surface of the aircraft fuselage in the vicinity of the antenna attachment point is modeled very accurately with a composite ellipsoid. The remainder of the fuselage and the wings and fins can be more crudely modeled by flat plates. The radiation patterns are then computed using the ellipsoid and flat plates in place of the actual physical model. This composite ellipsoid is actually two ellipsoids joined together at the antenna location in such a manner that their first derivatives are matched at that their union. Option 4_3 invokes a series of menus and submenus with many options and paths possible to achieve the ultimate goal of calculating the parameters of this composite ellipsoid so that it is a good model of the fuselage near the antenna attachment point. Fortunately, very good results can usually be obtained with the default responses. The following represents what the user is most likely to encounter:

⇒ Enter Frequency (MHz): `1275`

The frequency must always be specified in Megahertz. This frequency is

CHAPTER 5. [4] MODEL COMPARISON MENU

identical to that at which the fields will be calculated using Option 5_3. This frequency also sets the distance away from the antenna location on the surface of the body that the ellipsoid will try to match the surface. After the frequency is entered, the cross-section at the y location of the antenna is displayed in white and the region to be matched by the ellipse in RED. The user is next presented with three general methods to find the ellipse that best matches the cross-section cut in the xz-plane:

⇒ **Methods for the X-Z ellipse:**

⇒ 1 = rotated ellipse [default]

⇒ 2 = non-rotated ellipse

⇒ 3 = big circle

Of these three methods, **1** is the most general and usually gives the best fitting ellipse to the aircraft surface. This option allows the xz-plane ellipse to roll in the xz-plane to conform to the fuselage cross-section at the y coordinate of the antenna. By selecting **2** the non-rotated ellipse is calculated. This non-rotated ellipse will always have its major and minor axes parallel to the x and z-axes. At certain locations on an aircraft an ellipse may not be a good fit. In this case **3** may be used to generate a "big circle" approximation. After one of these methods is selected the program will calculate and display the best fit ellipse in GREEN. Probably more than any other parameter, the ellipse fit is dependent upon the extent of the cross-section which the ellipse is attempting to match, i.e., the RED region of the cross-section. If the fit is not satisfactory, then one must either choose a different method for the x-z ellipse fit or adjust the size or extent of this RED region. HARP now requests further instructions:

⇒ Repeat the X-Z ellipse process? t/f [f]:

If the ellipse displayed is satisfactory simply hit . If a better fit is desired, hit and for the following choices in two menus:

⇒ **Options to modify the match points:**

⇒ 1.) Antenna near corner

⇒ 2.) More local fit desired

CHAPTER 5. [4] MODEL COMPARISON MENU

- ⇒3.) Antenna on concave/convex boundary
- ⇒4.) Additional permutation
- ⇒5.) Return to original contour
- ⇒6.) No change [default]

This first menu controls the number of *points* along the contour that will be used for matching for a new ellipse, i.e., the extent of the red region. The functions of each of these items is exactly as expected from its descriptive line. For example option [1] is useful when the antenna is near a corner or sharp bend in the fuselage cross-section. Option [2] will make the red region smaller, resulting in a better local fit, but possibly a worse global fit. Only one of these items can be selected at a time. The method used to compute the ellipsoid parameters is very complex, and sometimes a better fitting ellipse is possible if additional testing and permutation is *forced* by option [4]. If this makes the fit less desirable, a return to the original contour is accomplished by using option [5]. After this choice is made, there are additional choices for the *ellipse*:

⇒Options for ellipses:

- ⇒1.) Force outside ellipse inside contour
- ⇒2.) Additional permutation
- ⇒3.) Return to original parameters
- ⇒4.) Change big circle radius multiplier
- ⇒5.) No change [default]

If [1] is selected an ellipse outside the contour is forced back inside the contour. Item [4] is used only if [3] was selected from the **Methods for the X-Z ellipse** menu. After making the choice the user is again presented with the **Methods for the X-Z ellipse** menu where the three methods of calculating the ellipse are available. It is at this point that the results of the choices made in these two menus can be seen. The user then comes back to:

⇒Repeat the X-Z ellipse process? t/f [f]:

If [t] is again selected, the HARP loops back through the preceding menus for

CHAPTER 5. [4] MODEL COMPARISON MENU

additional iterations. If the default is selected then the ellipse in the "Y-R" plane is calculated and displayed and the user has the following option:

⇒ Repeat the Y-R ellipse process? t/f [f]:

This Y-R ellipses are the ellipses orthogonal to the X-Z ellipse such that together they make up the composite *ellipsoid* in 3D. The "Y-R" plane is the intersection of the body of the aircraft with the a plane containing the y-axis, the antenna position and the center of the X-Z ellipse. If the user does wish to repeat this ellipse process, yet another menu is presented:

⇒ Options to modify the Y-R ellipses:

- ⇒ 1.) Antenna near a sharp turn
- ⇒ 2.) Additional permutation
- ⇒ 3.) Return to original contour
- ⇒ 4.) Increase width (in y) of ellipse ⇒ 4.) No change [default]

Sometimes the Y-R ellipse does not conform well to the surface. In this case using option will force a lengthening of the ellipse along the length of the aircraft fuselage. In this situation a better overall fit of the ellipsoid to the surface is usually obtained. After the user makes a choice from this menu, the ellipse is recalculated and redrawn on the screen. The user is then returned to:

⇒ Repeat the Y-R ellipse process? t/f [f]:

Assuming the default is accepted, the user is presented with the final menu for Option 4_3:

⇒ Options to repeat Composite Ellipse path:

- ⇒ 1.) Repeat, with new X-Z and Y-R ellipses
- ⇒ 2.) Repeat, with only a new Y-R ellipse
- ⇒ 3.) Finished [default]

Choice will start all over from the beginning. Choice will start over

CHAPTER 5. [4] MODEL COMPARISON MENU

with the Y-R ellipses. And the third choice is the final and only exit from Option 4_3.

5.4 4_4 Calculate UTD Plates

The UTD code (NEWAIR) [2] employed by HARP usually makes use of flat plates to represent aircraft surfaces and to provide other functions. Option 4_4 provides the user with an automatic way to generate these plates. It is important to keep in mind that this option generates plates to improve the high frequency model of the fuselage of the aircraft and it is not to be confused with Option 4_1 where flat plates are also used to model fins and rotor blades. This option was developed because, in many situations, the composite ellipsoid is not sufficient to accurately model the fuselage. The plates generated by this option are triangular in shape and are a function of the aircraft geometry, composite ellipsoid, and user input. Option 4_3 *must* have been successfully completed before Option 4_4 can be used to generate these plates because the ellipsoid data must be available. Upon invocation something like the following will appear on the screen:

```
⇒ The body y-minimum = 2.500000
⇒ The body y-maximum = 60.00000
⇒ The antenna y-position = 15.00000
⇒ The ellipse y-minimum = 9.679076
⇒ The ellipse y-maximum = 43.24205
⇒ Enter the y-stations [return to end]:
⇒ Enter y-station 1 : 
⇒ Enter y-station 2 : 
⇒ Enter y-station 3 : 
⇒ Enter y-station 4 : 

⇒ Making plates now...
⇒ Total number of triangular plates generated: 23
```

A *general* rule for selecting the y-stations is to pick one about one wavelength to the right of the ellipse y-minimum, another near the antenna location, and a final y-station about one wavelength to the left of the ellipse y-maximum.

CHAPTER 5. [4] MODEL COMPARISON MENU

Note that all these y-stations must be separated by a distance of about one wavelength. **Warning!** This option is still in the development stage. It is possible for this option to generate plate configurations that do not satisfy the constraints placed on plates by the NEWAIR code. When this occurs the NEWAIR code will fail and leave a brief explanation in the error file. If no plates are needed for the current model, this option can be skipped.

5.5 4_5 Display UTD Body

Option 4_5 assembles all available data (ellipsoid and flat plates) for the aircraft and presents it together in 3D. The chief value of this Option is to be able to see the composite ellipsoid created in Option 4_3 superimposed on the physical model of the aircraft. In this way, not only can the quality and appropriateness of the composite ellipsoid be ascertained, but the closeness of this ellipsoid's match to the physical surface of the aircraft becomes apparent. The composite ellipsoid is shown in BLUE and the physical body of the aircraft is displayed in a pseudo-translucent GRAY. Any plates created by Option 4_4 are displayed in RED. Like most graphics displays in HARP there are a number of function keys to toggle certain features of the display and fully programmed dial box functions that are used to manipulate the figure in 3D. These features are completely described in Appendix A.

5.6 4_6 Enter Towelbar Antenna

With this Option the user can create a "towelbar" antenna that can be used in place of the monopole created under Option 4_1. This antenna is actually a wire antenna composed of linear segments with vertices at arbitrary locations in 3D space that the user selects. At each vertex the user is asked of a source should be placed at that point. No matter how many segments are used to make up an antenna, only one source can be specified. Once specified, this source is marked with a \bigcirc on the screen. A typical invocation would look like this:

⇒ Enter Y location in inches:

CHAPTER 5. [4] MODEL COMPARISON MENU

⇒ Enter angle around body in degrees:

⇒ Enter height above body in inches:

⇒ Accept this point? [y]

⇒ Is there a source this point? [n]

⇒ Enter more points? [y]

After the user has finished entering the vertices, a data file is written that will optionally be picked up when the user invokes Option 4_2.

Chapter 6

[5] Field Calculation Menu

Up to this point everything has been in preparation for the electromagnetic field calculations. From Menu [5] all field calculations are initiated. There are three options in the menu. Two of them are for the field calculations and the other to verify the MM geometry. While the later may seem out of place in this menu, it is grouped here because it actually employs the *same* program (AMC). Options 5_1 and 5_2 exercise different aspects of the same computer code.

6.1 5_1 Build/Show MM Graphics

Option 4_2 prepares the input file for the MM code and then displays the *input* model. To see what the MM code “thinks” this model is, Option 5_1 is used. This option creates and/or displays this *output* model which is created by the MM code itself. Option 5_1 also provides a quick method to check that the input file is syntactically correct and that the host computer has enough RAM and other resources to at least start the MM calculation. It is assumed that the user will almost always make this so-called *pre-run* to verify the geometry and correctness of the input before making a full MM calculation using Option 5_2 which could take minutes to hours to complete. Upon invoking Option 5_1 the user is presented with the **Verify AMC Model Menu**:

< 1 > Build/show new geometry w/o current modes.

CHAPTER 6. [5] FIELD CALCULATION MENU

- < 2 > Build/show new geometry with current modes.
- < 3 > Show prior geometry w/o current modes.
- < 4 > Show prior geometry with current modes.
- < 5 > Abort with no further action.

Those options not possible will be *'d out, that is, the numbers of those operations not possible will be replaced by *. For example, if Option 4_2 had not yet been invoked, no AMC input file would exist so neither of the first two operations would be possible. Similarly, if operation one or two of Option 5_1 had never been invoked, then neither operation three nor four would be possible because no prior geometry file would exist.

The first four operations under Option 5_1 display the wire and polygonal plate geometry of the model that the AMC code will use in solving for the field patterns. Operations one and three simply show the polygonal plates, while operations two and four include arrows which illustrate how the current on the plates is represented by MM surface patch expansion functions. Note that this is an *output* from AMC and not the input geometry. These models are constructed from data contained in output files generated by the AMC code. Consequently, Option 5_1 or 5_2 must be run before these models can be displayed. Typically the user will run Option 5_1, which takes very little computer time, and compare the results with the model previously rendered with Option 4_2. If visual inspection shows the models to be consistent, the user can then commit to the more time consuming Option 5_2 to calculate the field pattern.

Operations two and four show the quadrilateral surface patch model of the aircraft, with the MM current modes indicated by small BLUE arrows. Wires (for the antenna or rotor blades) are shown as RED lines. Operations one and three are identical to two and four except the arrows representing the current modes are not shown. This presents a cleaner appearance when only the geometry is of interest.

The fifth operation provided in this submenu allows the user to safely abort Option 5_1 with no file changes or graphics attempted.

6.2 5_2 Do MM Calculation

Option 5_2 is used to initiate the full Method of Moments calculation of the desired field patterns using the model previously created in Option 4_2 and additional data requested upon invocation. Note that the *frequency* at which these calculations will be made has already been selected when the MM model was created using Option 4_2 and can not be changed at *this* point. This is because the MM surface patch model itself is frequency dependent. Since this model may have been created some time ago, the user is reminded of this frequency upon invocation of this option:

⇒ Frequency = 932.250 MHz

6.2.1 Specifying the Pattern Cut

The pattern cuts for the field calculations are selected next. There are two basic pattern cuts that can be specified. See Figure 6.1. The usual spherical coordinates are used where Θ is measured from the positive z-axis and Φ is measured from the positive x-axis in the direction shown. The first of these pattern cuts is an *azimuth-cut* where the angle Θ is fixed Φ is varied over the range $0 \leq \Phi \leq 360$ degrees. The angle Θ can range from 0 to 180 degrees. For angles < 90 degrees, the field pattern would lie on the cone shown in Figure 6.2. At $\Theta = 90$ degrees, the pattern would lie entirely in the xy-plane. For angles > 90 degrees, the pattern would lie on the cone aligned in the opposite direction to the one shown. The second of these pattern cuts is an *elevation-cut*. For an elevation-cut Φ is fixed and Θ is varied over the range $0 \leq \Theta \leq 180$ degrees, and then Φ is increased by 180 degrees and Θ is varied over the range $180 \geq \Theta \geq 0$ degrees. With $\Phi = 135$ degrees, the field pattern would lie in the plane of the circle in Figure 6.3. An elevation-cut at $\Phi = 90^\circ$ (top to tail to bottom to nose to top) is commonly referred to as an elevation plane pattern. An elevation-cut at $\Phi = 0^\circ$ (top to wing to bottom to wing to top) is commonly referred to as a roll plane pattern.

⇒ Available Pattern Cuts:

⇒ 1.) Theta fixed (az-cut)

CHAPTER 6. [5] FIELD CALCULATION MENU

⇒2.) Phi fixed (el-cut)

⇒3.) Abort run

Selecting means that the user wishes to fix the Θ angle in the usual coordinate system used for field calculations. This is usually referred to as an azimuthal-cut pattern. Choosing means that an elevation-cut pattern is desired. Here the angle Φ is fixed. To abort the field calculation is used.

If is selected for an azimuth-cut then the following pattern angle and increment are requested:

⇒Enter theta fixed angle now (in degrees) [90.0]:

⇒Enter the incremental step size in the theta fixed plane

⇒(in degrees) [5.0]:

The defaults in square brackets can be entered simply by hitting . If other values are desired they can be entered followed by . Note that the increment size must be *evenly* divisible into 360 degrees. If the user's input is not evenly divisible into 360, the same request will be made repeatedly until this condition is satisfied.

If is selected for an elevation-cut, the following data must be supplied:

⇒Enter phi fixed angle now (in degrees) [0.0]:

⇒Enter the incremental step size in the phi fixed plane

⇒(in degrees) [5.0]:

6.2.2 Saving and Reusing the MM Impedance Matrix

A large part of the time needed to compute the radiation pattern is consumed in filling and LU decomposing the impedance matrix. If the present run is for a geometry identical to a previous run, except for a possible change in the antenna location or its length or the rotor blade position, much of this time can be saved by reusing the LU decomposition of the impedance matrix from this previous run (assuming that this matrix has been saved). Only part of this matrix must be re-computed in this situation, saving time. Thus, the

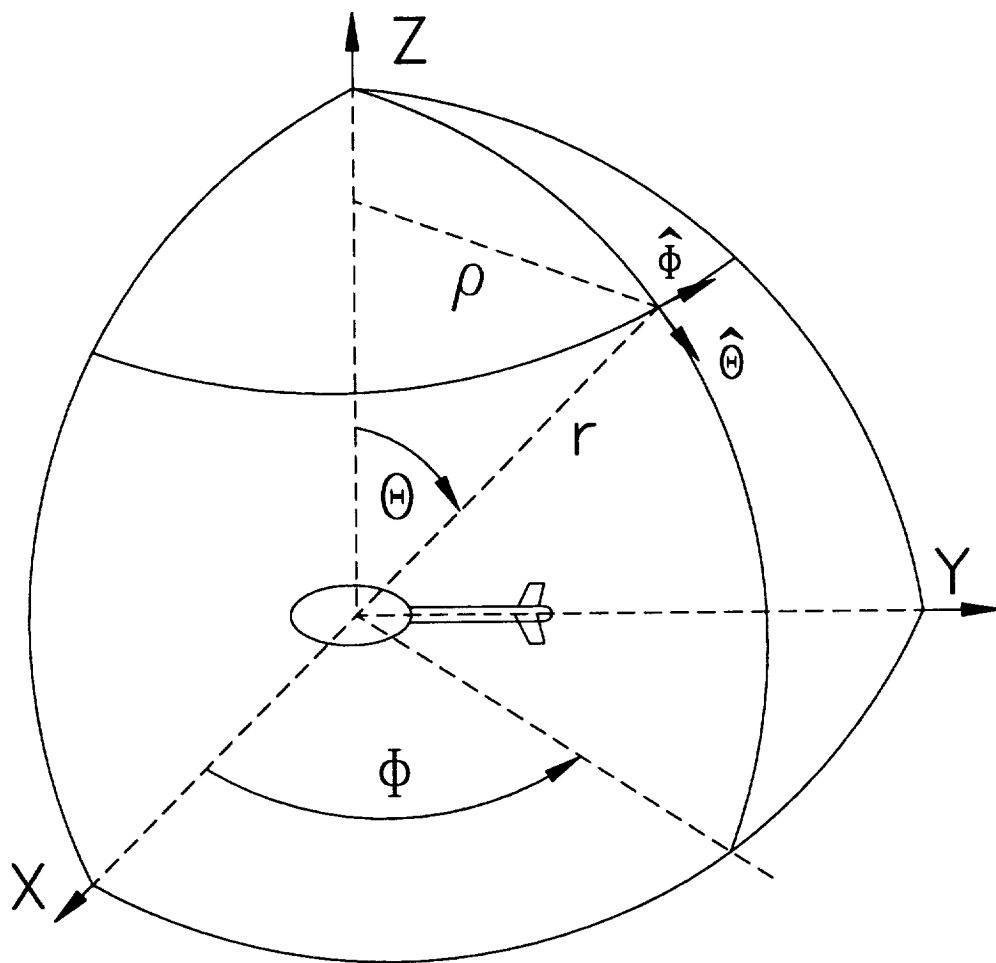

Figure 6.1: Azimuth-cut: Constant Θ , $0 \leq \Phi \leq 360$ degrees Elevation-cut: Constant Φ , $0 \leq \Theta \leq 180$ degrees, Elevation-cut: Constant $\Phi + 180$, $180 \geq \Theta \geq 0$ degrees.

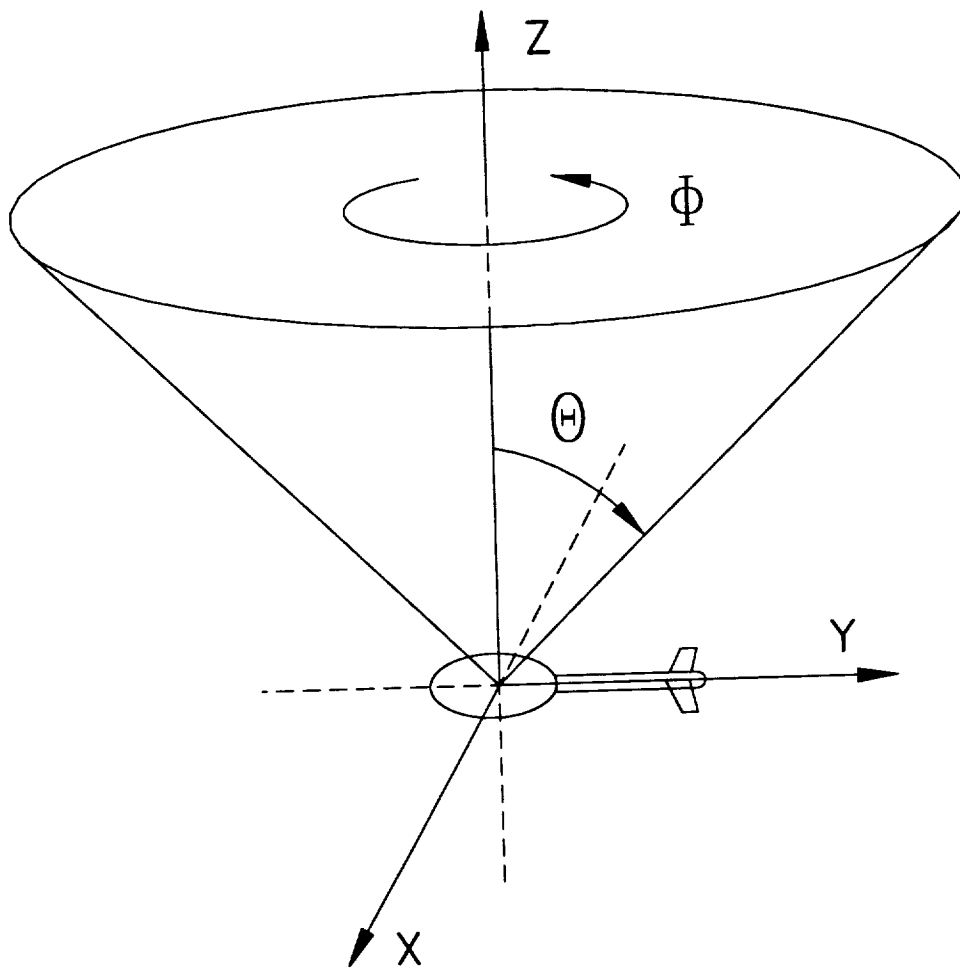

Figure 6.2: Azimuth-cut: Constant Θ , $0 \leq \Phi \leq 360$ degrees.

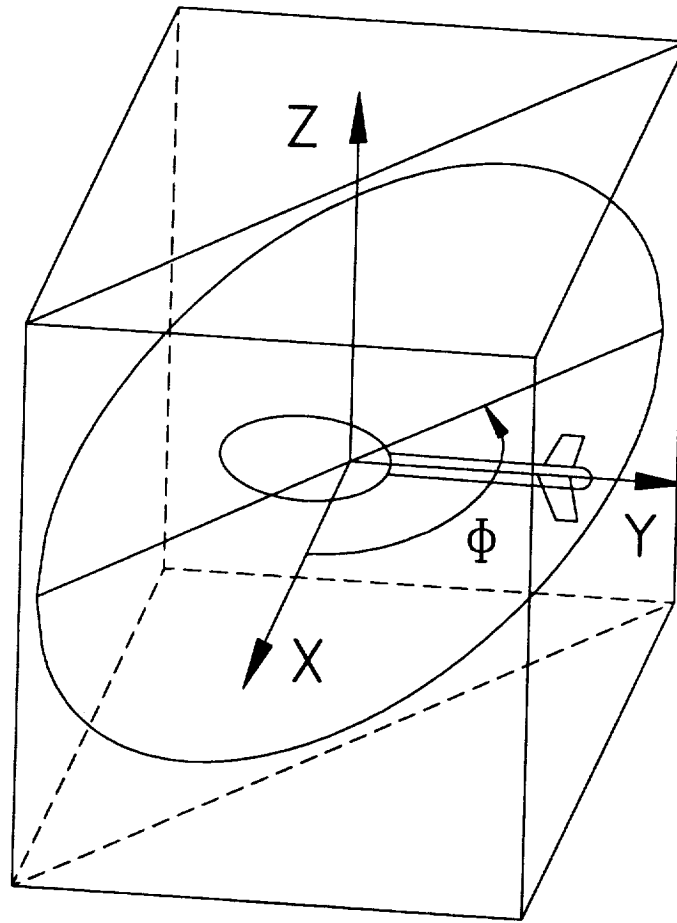

Figure 6.3: Elevation-cut: Constant $\Phi = 135$ degrees, $0 \leq \Theta \leq 180$ degrees for Φ , and $180 \geq \Theta \geq 0$ degrees for $\Phi + 180$ degrees. This yields a full 360 degree coverage in the plane of the circle.

CHAPTER 6. [5] FIELD CALCULATION MENU

next question the user sees asks:

⇒ Do you want to read or write the [Z] matrix? [N]

If the default answer is accepted, the Moment Method code is immediately started as a *background* job and the user is returned to Menu [5]. If an affirmative response is given then the following questions are asked:

⇒ Do you want to write the [Z] matrix? [N]

If a matrix file already exists:

⇒ Do you want to read the [Z] matrix from the disk? [N]

If the response is affirmative then the following must be determined:

⇒ Has the antenna and/or the rotor changed? [Y]

If affirmative, the elements of [Z] involving the antenna and/or rotor will be re-computed.

⇒ Has anything changed? [N]

To reuse the impedance matrix the model must not have changed in any way except for the antenna and/or the rotor assembly. Specifically, the frequency must be *identical*, the number of sides to the MM model must be identical and be made from the identical physical body. Finally, the fins attached to the body must have changed neither their geometry nor position. In short, the model must be *identical* to the one which stored the [Z] matrix to disk except for changes to the antenna and/or rotor geometry or position. After this last question has been answered, the Moment Method code is started as a background job and the user is returned to Menu [5].

6.3 5_3 Do UTD Calculation

Option 5_3 is for making the high frequency UTD calculations. Like Option 5_2 additional information must be provided after a reminder is displayed of the frequency at which the UTD model was created:

⇒ Frequency = 2142.250 MHz

The pattern cuts for the field calculations are selected next:

⇒ Available Pattern Cuts:

- ⇒ 1.) Theta fixed (az-cut)
- ⇒ 2.) Phi fixed (el-cut)
- ⇒ 3.) Abort run

These cuts are exactly like those discussed in Section 6.2 for Option 5_2. Unlike for the MM code, however, there are no specifications needed for the incremental step size in the fixed plane nor are there questions concerning an impedance matrix because none is used. Another chief difference between the UTD code and the MM code is the speed of calculation. Because the UTD code is able to complete the field calculations in much less time, it is *not* started as a background job. The user is returned to Menu [5] after the calculations have been successfully completed. One caveat: It is easy to forget when making a UTD calculation that in the NEWAIR code, it is assumed that the antenna length is $\leq \frac{1}{4}\lambda$. Thus, for the results of the calculation to be valid, a new antenna length should be specified using Option 4_1 if the current antenna is too long.

Chapter 7

[6] Field Display Menu

For graphical display of the calculated field patterns and for hardcopy output of these results, Menu [6] provides identical options for both the MM and UTD output data files. The screen plots are quick and require no additional user input. Additional flexibility has been added to the hardcopy options to allow the user to select polarization and scaling as well as output formats. Plots can also be automatically directed to a printer.

7.1 6_1 In-situ Plot MM Results

Option 6_1 displays the results of the latest MM field calculation on the screen in 3D. The physical model of the aircraft is displayed in the middle of the screen and the magnitude of the field strength is displayed around this model in the cut plane for which it was calculated. Both polarizations are loaded into the graphics system at the same time and can be toggled using the keyboard function keys as described in Chapter 8. Note that the polarization is indicated by the RED arrow on the right side of the plot field.

7.2 6_2 In-situ Plot UTD Results

In all respects Option 6_2 is identical to Option 6_1 except that it reads the data file from the UTD code instead of the MM code.

7.3 6_3 Hard Copy MM Results

The hardcopy output from HARP is very flexible in that it can create output in a variety of formats that can be processed by other software. It is also possible to have output automatically queued to a postscript capable printer. When Option 6_3 is first invoked the following is displayed on the screen:

⇒ Processing data from the lh family:

Here it is assumed that the family name is *lh*. Then the polarization is selected:

⇒ Select Polarization:

- ⇒ 1) Theta
- ⇒ 2) Phi
- ⇒ 3) Both
- ⇒ 4) Abort plotting routine

The default, [1], selects the theta polarization. If another family name is desired [4] can be selected to abort the program. Option 3_1 could then be used to set a new family name. Assume [3] was selected to plot both polarizations, then the user has a choice of automatically scaling the gain or setting it manually:

⇒ Auto scale gain [y]: n return

To scale the plot manually, the user should enter an [n] and follow it with a return. The default can be selected as usual by hitting return alone. Assuming the user has decided to scale the plot manually, the following statements appear on the screen indicating the range of the *gain* in dB data for each polarization:

- ⇒ Theta data is [low, high]
- ⇒ Phi data is [low, high]

CHAPTER 7. [6] FIELD DISPLAY MENU

The user is then asked to supply the following limits in dB for the magnitude and the step size of the desired plot:

```
⇒ Enter minimum: 
⇒ Enter maximum: 
⇒ Enter step size: 
```

The final option allows the user to add comments to the hardcopy output.

```
⇒ Add comments ? [n]: 
```

If exercised, this feature allows the user to enter two comment lines of up to 50 characters each to the plot page. If more than 50 characters are typed on either line, the extra characters are discarded and will not show up in the output comment field. To guide the user, a rule is printed before each comment line to be entered. A “|” marks every tenth column.

When Option 6_3 or 6_4 has finished accepting user input it writes a file in the *present working directory (pwd)* called *harp.plot*. This file contains standard unixplot statements and can be used with any of the standard drivers capable of interpreting unixplot commands. One important caveat here is that there can only be a single *harp.plot* file in a given directory at one time regardless of the number of family data files that may exist there. Each time Option 6_3 or 6_4 is invoked this file is over-written.

There are any number of ways to convert the *harp.plot* to useful output *manually*. *Outside* HARP at the command line the following could be typed to manually create a postscript file assuming the *plot2ps* driver exists on your system:

```
$ cat harp.plot | plot2ps > newplot.ps
```

This new file could then be printed in the usual way on any postscript printer.

A far better way to get hardcopy output, *automatically*, is to let UNIX do the work by setting a shell environment variable and simply *piping* the output to a postscript printer. The environment variable used by HARP for hardcopy output is HARP_PLOT. Note that this variable must be set *before* HARP is started and *cannot* be reset from inside HARP using Option 3_3.

CHAPTER 7. [6] FIELD DISPLAY MENU

This variable can be set manually before invoking HARP, as will be shown here, or set permanently in the *.bash_login* or *.bashrc* files. This is, of course, assuming that *bash* is the user's shell. Just what HARP_PLOT should be set to depends on what is desired. Let us assume that no permanent file is desired, but that all graphic output should go directly to the default postscript printer. One would then simply type the following at the command line before starting HARP:

```
$ export HARP_PLOT="plot2ps | lpr"
```

Then the *unixplot* output from Options 6_3 and 6_4 will automatically be converted to postscript and sent to the printer. All manner of combinations are possible. For instance, if it was desired to save the postscript output to a file as well as have it go directly to the printer, the following could be used:

```
$ export HARP_PLOT="plot2ps > newplot.ps ; lpr newplot.ps"
```

In this case Option 6_3 or 6_4 would create a postscript file called *newplot.ps* and then automatically print this file. The caveat, like that for the *harp.plot* file, is that there can only be one designated output file in a given directory. This file would be over-written each time Option 6_3 or 6_4 is invoked. Of course, all the different plots would be printed.

As a third example of using the HARP_PLOT environment variable to achieve a custom result, consider the situation where the postscript printer is in another office or building. In this situation it might be desirable to see what the printer output would be like on the screen. This is possible in a number of different ways, but one of the easiest is to set the environment variable before HARP is started like this:

```
$ export HARP_PLOT="plot2ps | ghostview -"
```

If the *plot2ps* and *ghostview* software is available on your system, setting HARP_PLOT equal to this string will cause HARP to display a copy of the normal printer output on the screen whenever Option 6_3 or 6_4 is invoked. The usual *harp.plot* file is also written to disk. To finish viewing the plot, select the *Quit* option from the pull-down menu under *File*. If the full Tekscreen

CHAPTER 7. [6] FIELD DISPLAY MENU

is in use, the *blue* "TekGraphics" box should then be clicked once with the left mouse button. The user will then be returned to the usual HARP menu system.

These are only a small sample of the possibilities for plot output built into HARP. Setting up printer queues and providing drivers, however, is beyond the scope of this work and will not be discussed here.

Chapter 8

Complete Examples

The preceding chapters have prepared the user to enter cross-sections, build a model from these cross-sections, add fins and rotor blades, and finally to make the field calculations. Perhaps the best instruction, however, is a good example. In this chapter a small helicopter (like that used by police departments) will be constructed and field patterns will be calculated using both the MM and UTD methods. By actually doing the examples provided here the user should become comfortable with HARP and be able to enter actual helicopter geometries that will produce reliable field patterns.

8.1 Entering the Cross-Sections

The cross-sections for our example helicopter are shown in Figure 8.1. In this example it is assumed that a new subdirectory called *example* has been created, but nothing else. HARP's output to the screen will be marked with long arrows and the user response will be indicated in boxed *italics*. Assuming HARP is started in a new directory the following is output to the screen:

```
⇒Welcome to the HARP program
⇒Harp initializing, please be patient!

⇒A family name has not been set in this directory.
⇒Please enter the new default family name: 
```

CHAPTER 8. COMPLETE EXAMPLES

⇒ The level of family name conformation used in HARP
⇒ can now be set. The flexibility of the HARP system is
⇒ affected by the level set. Please take note.

⇒ Enter a 1 for Expert level with maximum confirmation
⇒ or a 0 for Novice level with minimum confirmation [0]:

Next the default units menu will *automatically* be called because no default units have yet been set in this directory:

⇒ **Default Units**

⇒ < 1 > You want to work in meters.
⇒ < 2 > You want to work in centimeters.
⇒ < 3 > You want to work in feet.
⇒ < 4 > You want to work in inches.

⇒ Enter option...[1]:

Having hit in this case, meters are automatically selected as the default unit for distance. The user is then placed in the **HARP Main Menu** where Option M_1 should be selected, i.e., Option 1 from the Main Menu. This action places the user in Menu [1] of the HARP system, the **Geometry Entry Menu**. Cross-sections can now be entered by invoking Option 1_1. There will be twelve cross-sections in all, but only seven will need to be entered on the tablet. How the others will be created will be demonstrated in Section 8.2. The seven cross-sections will be entered by digitizing the curves provided in Figure 8.1. For best results these curves should be entered as accurately as possible with up to fifty points each. The total number of points entered is shown in the lower right side of the screen as they are entered. While the accuracy of the model is good with a relatively few points, best accuracy is achieved with thirty or forty points. The tendency to enter too few points should be avoided, especially in the smaller cross-sections. If the cross-sections entered on the tablet do not appear on the screen as those in Figure 8.1, do not hesitate to try again. HARP will allow a new file to be written with the *same* extension number,

CHAPTER 8. COMPLETE EXAMPLES

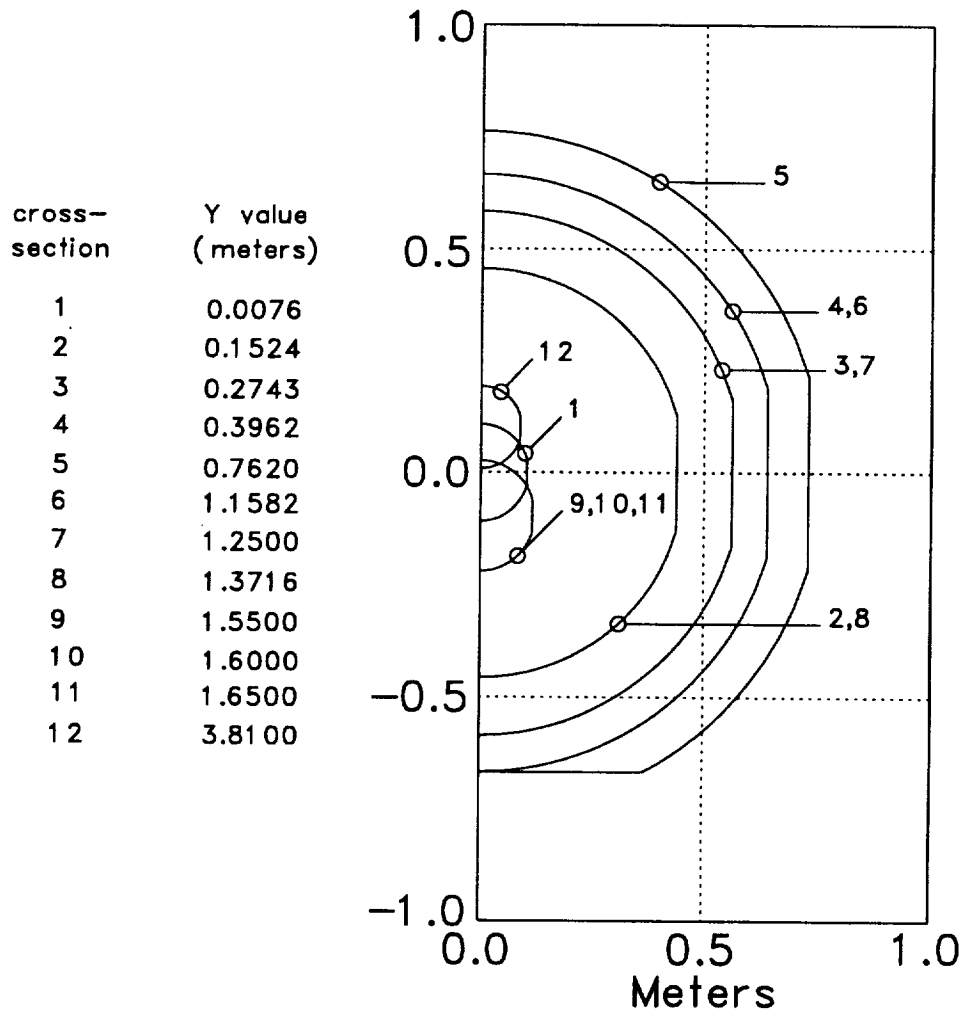

Figure 8.1: The cross-sections used to build the example esl helicopter.

CHAPTER 8. COMPLETE EXAMPLES

but only after conformation to do so from the user.

Each cross-section file must have a unique extension number. These numbers need *not* be in any order, but it is usually a good idea for them to be in increasing value as the y coordinate value of the cross-section increases from the nose to the tail of the aircraft body. Twelve cross-sections could also be entered consecutively from 1 to 12, but experience has shown that it is usually good practice to skip one or two consecutive numbers between cross-section extensions so that additional cross-sections can be added between those already entered should that prove desirable. Having provided this caveat, it can also be stated these extension numbers provided by the user are irrelevant to the internal operation of HARP. They could be completely random and it would in no way impair the operations of HARP. The only requirement is that each be unique. Having stated the above, to keep this example simple, the cross-sections will consecutively numbered from 1 to 12. The curves marked 1,2,3,4,5,9, and 12 in Figure 8.1 will be digitized on the tablet. These numbers will also correspond to the extension numbers for the cross-section files.

The user input in this example, as usual, is shown like `this`. All information needed to enter the cross-sections is shown in Figure 8.1. Upon invocation of Option 1_1 the user will see the following where it is assumed that the user has hit `return` after each input shown:

⇒ Now enter the model description line.

⇒ >>: `Section one, nose`

⇒ Enter the cross section file number (extension)... `1`

⇒ Enter the y-station location for cross-section 001 in meters: `.0076`

⇒ Is this a symmetric cross-section [Y] ? `return`

⇒ Enter two points to use as a known distance on the tablet

In Figure 8.1 this could be *known* distance such as 0.0 and 1.0 on the horizontal axis or -1.0 and 1.0 on the vertical axis. We choose the former here.

⇒ Enter this distance in meters: `1.0`

⇒ Enter the cross-section origin on the tablet.

CHAPTER 8. COMPLETE EXAMPLES

Note that *all* the cross-sections must have a common origin even though each cross-section may not encircle this point. The origin used in this example is located at the point (0.0, 0.0) in Figure 8.1. While it is generally desirable to have this origin close to the centroid of the cross-sections, any consistently used point will work. This is a key point to remember when cross-sections are entered from different pages of an aircraft blueprint. **All cross-sections must have a common origin.** Continuing with the example:

⇒ Enter any reference on the positive (up) z-axis

This fixes the coordinate system for the tablet.

⇒ Enter the half cross-section now starting on the + z-axis

⇒ Progressing clockwise, stopping on the - z-axis,

⇒ Enter 6 to 50 POINTS, use BLUE to enter the last point.

⇒ (Use GREEN to delete previously entered points.)

Again, it is recommended that 30 or 40 points be entered. If the entered cross-section does not look like Figure 8.1, enter it again. Remember that the overall model can be no better than the cross-sections from which it is built. HARP always asks if more cross-sections are to be entered after each is completed.

⇒ Do you wish to enter another cross-section? [Y]

The foregoing procedure is repeated exactly for curves 2,3,4,5,9, and 12. Do *not* continue with this example until these cross-section curves have been entered and look like those in Figure 8.1.

8.2 Building the Master File

Assuming the seven cross-sections were properly entered as described in Section 8.1, additional cross-sections can now be created and a master file can be built. This is accomplished with Option 1_2. The first operation to be performed is the creation of new cross-sections from those already entered.

CHAPTER 8. COMPLETE EXAMPLES

Notice in Figure 8.1 that cross-sections 9,10, and 11 are identical, except for their y-values. Similarly, 2 and 8, 3 and 7, and 4 and 6 are the same except for their y-values. The *c-copy* operation provides a quick method to create new cross-section files by copying the data from one file to a new one. A different y-value can then be specified for the new file. Note that these new cross-sections could be entered just like the first seven, however, Option 1_2 is easier and more accurate. Not only will the *c-copy* operation save time, but experience has shown that a better, more predictable model results from its use. Invoking Option 1_2 brings up the following choices:

```
⇒l-ist, b-uild, c-opy, y-location, i-nfo, n-ame, d-elete, r-edraw, e-xit:
⇒Enter your choice now [L-ist]: 
```

Selecting the default by hitting will list the cross-section files created in Section 8.1. Assuming the seven files are present, the new files can be created. Cross-sections files 10 and 11 can be created from 9 and the y-value data in Figure 8.1:

```
⇒l-ist, b-uild, c-opy, y-location, i-nfo, n-ame, d-elete, r-edraw, e-xit:
⇒Enter your choice now [L-ist]: 
```

```
⇒What is the extension number of the cross-section file
⇒that you want to copy? [none]: 
```

```
⇒What is the extension number of the new cross-section
⇒file that you want to create? [none]: 
```

```
⇒The current preferred distance unit: meters
⇒The original y value : 1.550000
⇒Enter new y value : 
```

In an identical manner the file for cross-section 11 could be created from the file for 9 or the new file for 10. Do that now. Copy 10 to 11, 2 to 8, 3 to 7, and, finally 4 to 6, being sure to pick the correct y-values from Figure 8.1 for these new files. When finished, list the files again. There should be twelve of them. Pay particular attention to the y-locations listed for each file. They should be identical to the y-values listed in Figure 8.1. Make all

CHAPTER 8. COMPLETE EXAMPLES

necessary corrections before proceeding.

The master file can now be created by selecting *b-uild*:

⇒l-ist, b-uild, c-opy, y-location, i-nfo, n-ame, d-elete, r-edraw, e-xit:

⇒Enter your choice now [L-ist]:

⇒There are 12 cross-section files.

⇒Do you want to exclude any cross-sections from the master? [n]

⇒File esl.master was written.

This completes the operations necessary to build the physical model of the *body* of the aircraft.

8.3 Adding Fins, an Antenna, and a Rotor

To complete the example *esl* helicopter, fins, rotor blades and an antenna must be added. From the **HARP Main Menu**, Option **M_4** is selected. This places the user in Menu [4], the **Model Comparison Menu**. To add these new features to our model, Option **4_1** is invoked. When the **Fin Control Menu** appears in the screen, select Option 2:

⇒File esl.fins does NOT exist.

⇒Enter fins now [Y] ?

The fin design shown in Figure 8.2 can now be digitized on the tablet:

⇒On the tablet, enter two points a known distance apart.

For these points use the tips of the double ended arrow that is labeled 0.6 meters.

⇒Enter this distance in meters:

⇒Enter the leading attachment point on the tablet.

CHAPTER 8. COMPLETE EXAMPLES

This is the point marked with “circle” arrow 1. Next digitize the second, third, and fourth points as HARP requests them by lining up the crosshairs of the digitizing puck over these points and depressing the YELLOW button.

⇒ Enter fin leading Y value in meters:

This information comes from the caption for Figure 8.2.

⇒ Fin attachment angle from +x-axis around body (degrees):

⇒ Fin inclination from +x-axis (degrees):

⇒ Enter the fin description tag now:

⇒ Enter more fins [Y] ?

⇒ Do you wish to reuse (copy/mirror) the fin planform [N]?

⇒ Enter either 1 for copy or 2 for mirror [2=mirror]

⇒ Enter more fins [Y] ?

Next comes the **Antenna Menu** where should be selected for a new antenna.

⇒ Enter antenna y value in meters:

⇒ Attachment angle from +x-axis around body (degrees):

This will place the antenna on the tail boom of the helicopter.

⇒ Enter antenna length in meters:

This is a quarter wave at 200 MHz.

CHAPTER 8. COMPLETE EXAMPLES

⇒ Enter angle with + x-axis (phi) :

This means that the projection of the antenna in the xy-plane would be pointing straight back to the tail.

⇒ Enter angle with + z-axis (theta) :

Here the projection of the antenna in the yz-plane would show the antenna tilting back 20 degrees from the vertical.

⇒ Do you wish to save the antenna data to a file? [Y]

After finishing the specification for the antenna, the Rotor Blade Menu is presented. Selecting from this menu initiates the procedure for specifying the rotor blade assembly. The data for the rotor assembly is provided in drawing and caption in Figure 8.3.

⇒ On the tablet, enter two points a known distance apart.

The tips of the 2.5 meter double ended arrow in Figure 8.3 should be entered for these points.

⇒ Enter this distance in meters:

Now enter each of the six points, in order, marked by the "circle" arrows in Figure 8.3. Be sure to use the BLUE button on the puck to specify the last point.

⇒ Enter the number of blades on the rotor:

⇒ Enter the y-location for the rotor in meters:

⇒ Enter angle with the + x-axis (phi):

⇒ Enter the height of the rotor in meters:

⇒ Do you wish to save the blade data to a file? [Y]

The example helicopter should now be displayed on the screen. The various

CHAPTER 8. COMPLETE EXAMPLES

dials on the dial box can be used to manipulate the helicopter in 3D so that all aspects of the model can be inspected for correctness. The capabilities of the dial box and certain function keys are fully explored in Appendix A.

8.4 Building the MM Model

To build the MM model, Option 4_2 is invoked. In this case the fields will be calculated for 200 MHz using the default responses to all questions except the last one concerning the attachment mode.

⇒ Enter the desired angle of the first blade

⇒ with the positive x-axis (in degrees) [0.0]:

⇒ Enter the desired fore-aft tilt (in degrees) [0.0]

⇒ Enter 6 to 16 body sides [10]:

⇒ Enter frequency (MHz):

⇒ Enter segmentation size in lambdas between cross-sections [0.2]:

⇒ Enter the attachment radius in meters (0 = none) [0.2817]:

By selecting , no attachment mode will be used. The MM model will then be calculated and displayed on the screen. As always, the dial box can be used to manipulate the model for complete inspection in 3D.

8.5 Making the MM Calculations

To calculate the field patterns for the model just created, from the **HARP Main Menu**, select Option M_5 to get to the **Field Calculation Menu**. From this menu there are two options to handle MM calculations. Option 5_1 does not perform field calculations. It is used to verify the MM model *actually* used to make the field calculations by creating a new model from the output created by Option 4_2. Note that this is distinct from the graphical display

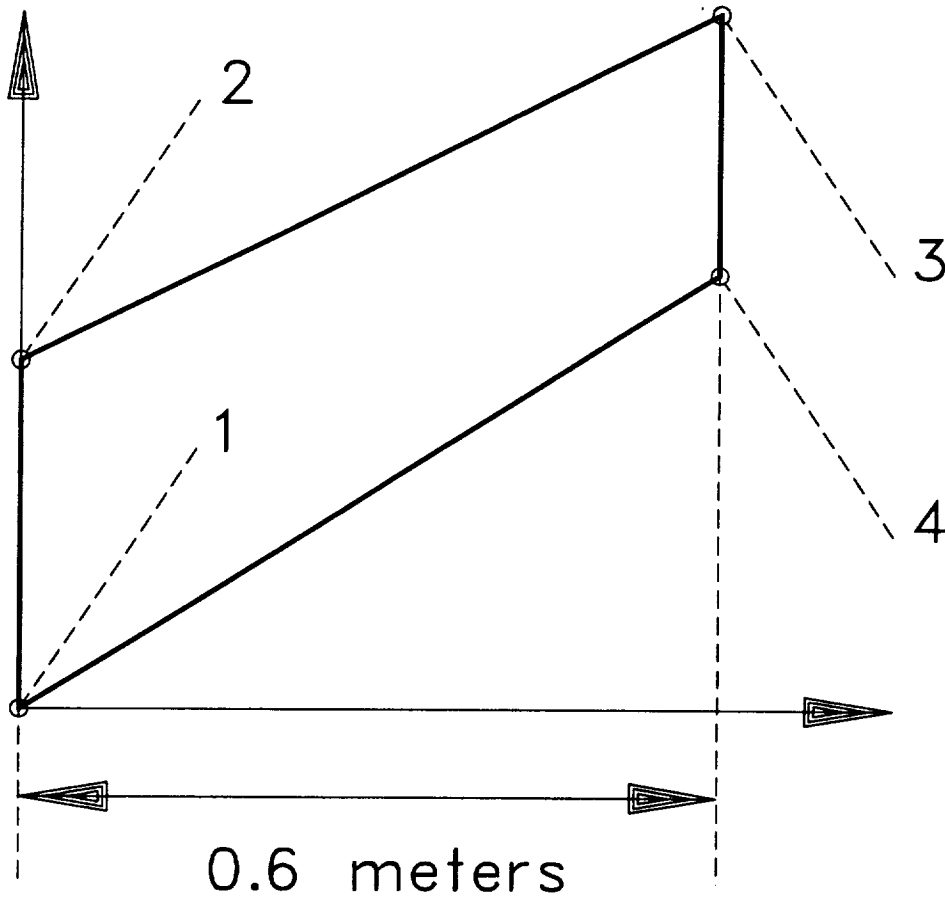

Figure 8.2: The fin design for the esl helicopter. The leading y-location for the fin is 3.5 meters, the attachment angle is 40 degrees, and the fin inclination with the +x-axis is also 40 degrees.

CHAPTER 8. COMPLETE EXAMPLES

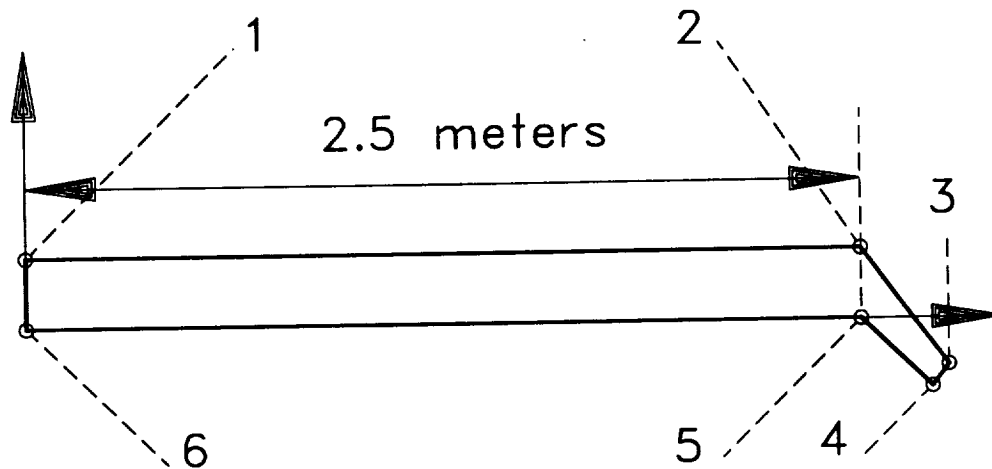

Figure 8.3: The rotor blade design for the es/ helicopter. The y-location for the rotor is 1.2 meters, the angle with the +x-axis is 90 degrees, and the height of the rotor is 0.24 meters.

created by Option 4_2. To view this model for correctness, Options 4_3 and 4_4 are used. To do the field calculations for the example es/ helicopter invoke Option 5_2 at this time and take the default responses for each question. These calculations will take a few minutes to complete. Option 3_5 can be used to check the progress of the run. After the run has completed, Option 6_3 can be used for hardcopy output. See Section 8.8 for details. The output should appear like that in Figure 8.4.

8.6 Building the UTD Model

From the **HARP Main Menu** select Option M_4. Then from the **Model Comparison Menu** select Option 4_5 to calculate the UTD ellipsoid. Before calculating this ellipsoid, however, a new antenna needs to be selected. **Warning!** This antenna *must* be $\leq \frac{1}{4}\lambda$. Thus the antenna specified for the low frequency MM calculations cannot be used. Invoke Option 4_1 and specify a new antenna in the same way as shown in Section 8.4 with the following data. Be sure to take the defaults for the fins and rotor blades. **Warning!** At

CHAPTER 8. COMPLETE EXAMPLES

the present time, the plates generated with Option 4_1 are not incorporated into the input data for the NEWAIR code. Work is currently in progress to add this capability to the HARP code.

⇒ Enter antenna y value in meters:

⇒ Attachment angle from +x-axis around body (degrees):

⇒ Enter antenna length in meters:

⇒ Enter angle with + x-axis (phi):

⇒ Enter angle with + z-axis (theta):

The above two angles should be entered; however, the NEWAIR code does not use them because it is assumed that the antenna is directed normal to the surface.

⇒ Do you wish to save the antenna data to a file? [Y]

Now Option 4_5 can be invoked to calculate the UTD ellipsoid.

⇒ Enter frequency (Mhz):

Now select , the **non-rotated ellipse** option from the **Methods for the X-Z ellipse** menu. The default should be accepted for all other questions by hitting . The resulting ellipsoid can be viewed by invoking Option 4_6 where it is displayed with the physical body it represents.

8.7 Making the UTD Calculations

Now the UTD calculations can be made using Option 5_3.

⇒ The plate data file `esl.plates` does not exist...

⇒ Continue anyway ? [Y]:

CHAPTER 8. COMPLETE EXAMPLES

⇒ Frequency: 2000.000 MHz

⇒ Available Pattern Cuts:

⇒ 1.) Theta fixed (az-cut)

⇒ 2.) Phi fixed (el-cut)

⇒ 3.) Abort run

⇒ Enter choice now [1]:

⇒ Enter theta fixed angle now (in degrees) [90.0]:

The UTD code will then run to completion in the foreground almost immediately. This is unlike the MM code which is launched in the background because it can take minutes or hours to complete. The hardcopy output described next should appear like that in Figure 8.5.

8.8 Field Plots and Hardcopy Output

Select Option M_6 from the HARP Main Menu for the Field Display Menu. Option 6_1 will display the field patterns calculated by the MM code on the screen, while Option 6_2 will display those calculated by the UTD code. To get hardcopy, output Options 6_3 and 6_4 are used. Assume first that a postscript printer has been set up as your default printer. Further assume that the following environment variable was “exported” before HARP was invoked:

```
$ export HARP_PLOT="plot2ps | lpr"
```

Now plots will automatically be queued to your postscript printer when Option 6_3 or 6_4 is invoked. The HARP hardcopy output should look like that in Figures 8.4 and 8.5.

HARP

Helicopter Antenna Radiation Prediction

Family name: esl

Freq: 200.00 MHz

MM computation in AMC

Comments: Low frequency patterns for the esl helicopter.

Antenna Data:

Type: Monopole
Length: 0.375 m
User's placement:
y = 2.70 m @ 90.0 deg.
 Θ : 90.0, Φ : 20.0 deg.
Base: (0.00,2.70,0.04) m
Top: (0.00,2.83,0.39) m

Pattern Data:

Azimuth plane pattern
 Θ fixed at 90.0 deg.

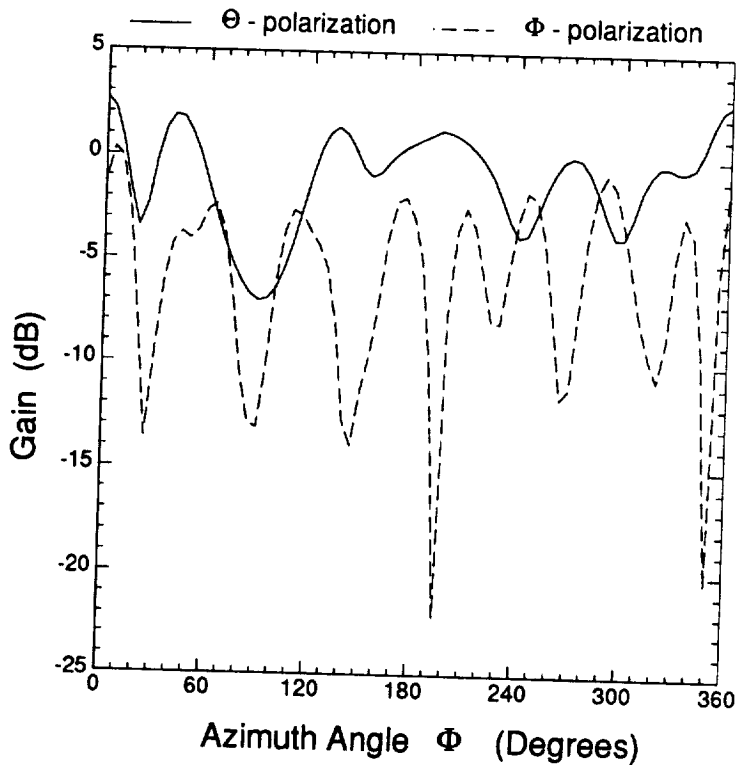

Node: tesla
Sysname: tesla, 3.2e
Machine: XD88/30

Plot number: 712620844
Friday Jul 31, 06:14 PM

Figure 8.4: The MM hardcopy output for the example in the text.

HARP

Helicopter Antenna Radiation Prediction

Family name: esl

Freq: 2000.00 MHz

UTD computation in NEWAIR

Comments: High frequency patterns for the esl helicopter.

Antenna Data:

Type: Monopole
Length: 0.030 m

User's placement:
y = 1.30 m @ 90.0 deg.
 Θ : 90.0, Φ : 20.0 deg.

Base: (0.00, 1.30, 0.55) m
Top: (0.00, 1.31, 0.57) m

Pattern Data:

Azimuth plane pattern
 Θ fixed at 90.0 deg.

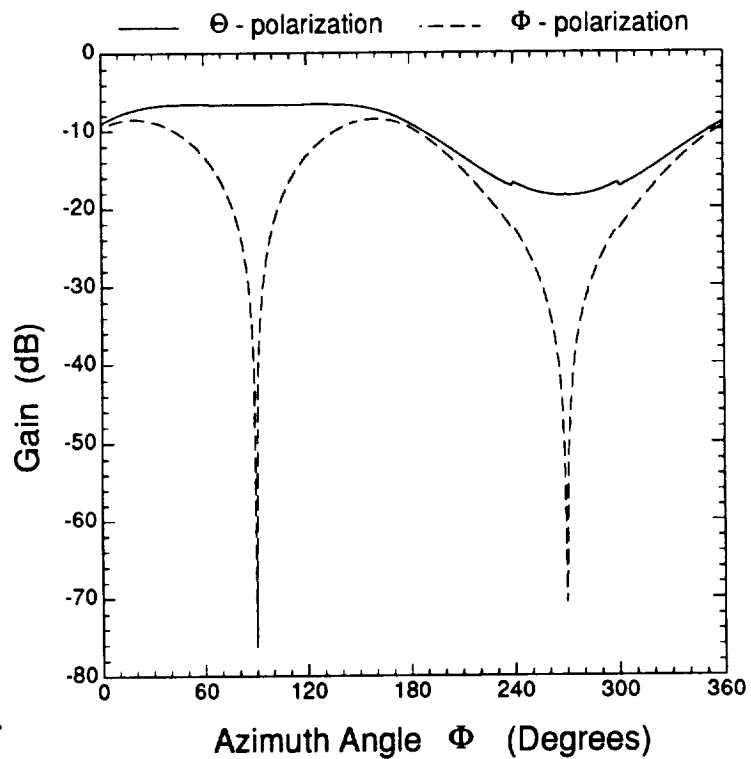

Node: tesla
Sysname: tesla, 3.2e
Machine: XD88/30

Plot number: 712965296
Tuesday Aug 04, 05:54 PM

Figure 8.5: The UTD hardcopy output for the example in the text.

Bibliography

- [1] M. Peters and E.H. Newman, "A User's Manual for the Method of Moments Aircraft Modeling Code," Ohio State Univ. Research Foundation Report 716199-14, prepared under grant NSG 1498 between the Ohio State University Research Foundation and the National Aeronautics and Space Administration, Langley Research Center, September 1989.
- [2] W.D. Burnside, J.J. Kim, B. Grandchamp, R.G. Rojas and P.H. Law, "Airborne Antenna Radiation Pattern Code User's Manual," OSU-ESL Technical Report 716199-4, generated under Grant NSG 1498, for NASA Langley Research Center, Sept. 1985.

Appendix A

Dial Box and Function Keys

HARP is designed to operate efficiently with a dial box, and it is assumed that your workstation is equipped with such a device. The Tektronix dial box is a gray box with eight knobs and two liquid crystal display (LCD) panels. This box is interfaced to the XD88 workstation's graphics system, and is used to manipulate the various 3D images created by HARP. The user has the flexibility to inspect the models by rotating, translating, and zooming in on any interesting aspect of the model. The function of each knob is labeled just above it on the LCD screen. The function of the dial box varies slightly from Option to Option. For each Option in HARP that uses the dial box, a complete description is provided in this chapter of the functions provided.

The keyboard of the Tektronix XD88 has several function keys. These keys, marked F1 through F8 plus the "Help" key, have been programmed to provide additional functionality and flexibility to the HARP user. The operation of these function keys is also described in this chapter. When functions are active, their operation is summarized by a legend at the bottom of the screen (unless they have been toggled off with the Help key).

Each of the Options that use these capabilities will be described here with the convention that D5, for example, will mean dial box knob number 5. The function keys will be specified similarly. All Options that are capable of displaying 3D graphics have the *same* functions programmed into the same dial box knobs. Options 4_1, 4_2, 4_5, 5_1, 6_1, and 6_2 all have the same dial box function for the same knobs. These functions are as follows:

D1 translates the aircraft model along the HARP x-axis.

APPENDIX A. DIAL BOX AND FUNCTION KEYS

D2 translates the aircraft model along the HARP y-axis.

D3 translates the aircraft model along the HARP z-axis.

D4 has no currently programmed function.

D5 sets the roll plane of the aircraft model. Adjusting this knob rolls the model in place.

D6 sets the pitch plane of the aircraft model. Adjusting this knob rotates the model in place, end over end.

D7 sets the yaw plane of the aircraft model. Adjusting this knob turns the model to port or starboard about its midpoint.

D8 is the zoom control which essentially adjusts the magnification of the image on the screen.

For Option 4_1 the following function keys have been programmed:

F1 rotates the main rotor blades for helicopter models.

F2 toggles the main rotor blades on and off.

F3 toggles between top and side views of the aircraft model

F4 places the model in the standard position and attitude it had when it was first drawn on the screen.

Help toggles the key labels at the bottom of the screen on and off.

For Options 4_2, and 5_1 the following function keys have been programmed:

F3 toggles between top and side views of the aircraft model

F4 places the model in the standard position and attitude it had when it was first drawn on the screen.

Help toggles the key labels at the bottom of the screen on and off.

Option 4_5 has the most function keys programmed:

APPENDIX A. DIAL BOX AND FUNCTION KEYS

F1 toggles the translucency of the aircraft body on and off so that its closeness of fit with the UTD ellipsoid can be more easily ascertained.

F2 toggles the graphical segment highlighting on and off. This feature enhances the appearance of the model when it is on and allows for more rapid movement of the model with the dials when it is off.

F3 toggles between top and side views of the aircraft model

F4 places the model in the standard position and attitude it had when it was first drawn on the screen.

F5 toggles the rotor blades on and off

F6 toggles the body of the aircraft model on and off.

F7 toggles the UTD ellipsoid on and off.

F8 toggles auxiliary plates used in the UTD code on and off.

Help toggles the key labels at the bottom of the screen on and off.

Options 6_1 and 6_2 have the following function keys programmed:

F1 toggles between displaying the θ and ϕ polarizations.

F4 places the model in the standard position and attitude it has when it is first drawn on the screen.

Help toggles the key labels at the bottom of the screen on and off.

Function keys and dials that have not been programmed have no effect on the operation of HARP. The function keys that have been programmed are always labeled at the bottom of the screen. The dial box knobs that have been programmed are always labeled in the LCD screen above the knobs. While not exactly function keys, there are two other functions that are initiated at the menus by typing designated characters. At the **HARP Main Menu** entering `v return` will display the HARP version number and other data. At *any* HARP menu the graphics images can be cleared by entering `c return`. HARP is not case sensitive to these inputs.

Appendix B

The HARP Executable Images

Each of the menu options in HARP is tied to one or more executable images that are located in \$HARP_BIN. In the following list the Option number is followed by the name(s) of the executable image(s) tied to it in boldface.

- 1_1 **enter_xct** enters body cross-sections.
- 1_2 **build_master** builds/modifies the master file.
- 1_3 **silhouette** shows 2D silhouettes of the fuselage.
- 1_4 **pre_viper**, **viper** makes new cross-section files by interpolating two original cross-section files.
- 3_1 **set_cfn** sets family name and preferred distance units.
- 3_2 **set_units** sets user's preferred units for distance.
- 3_3 **harp_shell** temporarily exits HARP to user's shell.
- 3_4 **bug_report** sends a bug report via email to Ohio State.
- 3_5 **predict** predicts completion times for MM calculations.
- 3_6 **noah** archives/recovers data files for a given family name.
- 3_7 **harp_status** writes a summary sheet of HARP data.
- 3_8 **write_amc_defaults** sets temporary AMC defaults.

APPENDIX B. THE HARP EXECUTABLE IMAGES

- 4_1 **erb** makes the fuselage model and allows addition of fins, antennas, and a rotor.
- 4_2 **mrb** makes the AMC input file and displays its geometry.
- 4_3 **find_ellipse** calculates NEWAIR ellipsoid parameters.
- 4_4 **gtd_platemaker** calculates NEWAIR plates.
- 4_5 **gtd_model** shows the complete NEWAIR model.
- 4_6 **towelbar** provides the user with a graphical way to enter a "towelbar" antenna to be used by the AMC code.
- 5_1 **amc_preprocess, amc, modes, geom** shows the AMC output model.
- 5_2 **amc_preprocess, amc** makes the MM calculation with AMC.
- 5_3 **newair_manager, newair_preprocess, air7, newair_postprocess** makes the UTD calculation with NEWAIR.
- 6_1 **insitu** shows the AMC (MM) results on the screen.
- 6_2 **insitu** shows the NEWAIR (UTD) results on the screen.
- 6_3 **harp_unixplot** prepares hardcopy output of AMC (MM) results.
- 6_4 **harp_unixplot** prepares hardcopy output of NEWAIR (UTD) results.

You will notice that a number of different menu options call the *same* executable image or images. What makes these options different is that each uses a different *internally* generated command line argument. For instance, Options 5_1 and 5_2 both call **amc_preprocess**, but Option 5_1 uses *pre-run* as an argument while Option 5_2 uses *full-run*. After preprocessing, **amc** is internally called to do the appropriate calculations. Similarly, Options 6_2 and 6_3 both call **insitu** with arguments *.amc_plot* and *.newair_plot*, respectively.

Choosing Option 5_3 to do the UTD calculations actually invokes four separate executable images. **Newair_manager** calls **newair_preprocess** to prepare an input file and then calls **air7** to actually do the calculations. Finally **newair_postprocess** is invoked to translate the output into HARP coordinates.

Appendix C

Data Files Used by the HARP System

The data used by HARP is kept in a number of different files. Three of these files, **CFN**, **UNITS**, **harp.plot**, and **AMC_temp_defaults** are common to *all* family names in a given directory. The rest of the files are always specific to a family name. Assuming a family name of /em esl, the following files could exist:

- **AMC_temp_defaults** is a temporary file that should exist only if Option 3_8 is used to set new defaults for the AMC code. This file is only used in Option 5_2 where it modifies the standard defaults for the MM code.
- **CFN** contains data on the current family name and expert level. It is used by all HARP codes to automatically pick up the family name.
- **UNITS** contains flags for the current default unit for distance.
- **esl.001 - esl.012** are the cross-section data files created by Option 1_1.
- **esl.amc_currents** contains the amplitudes of the current modes calculated by the AMC MM code. This file is not currently used by HARP.
- **esl.amc_errors** contains all the warnings and errors generated by the AMC MM code. In rare circumstances the MM code may run to completion, but yield strange results. Clues to the possible reason for these results may be contained in this file.

APPENDIX C. DATA FILES USED BY THE HARP SYSTEM

- **esl.amc_fullrun** is the input file used for complete MM field calculations.
- **esl.amc_geom** is the output file generated by the AMC MM code that contains geometry information about the model. It is this file that is displayed by Options 4_3 and 4_4.
- **esl.amc_output** is the general output file for the MM code and contains a wealth of information about modes, cross-sections, sources, and more.
- **esl.amc_plot** contains the electromagnetic field data calculated by the AMC MM code.
- **esl.amc_prerun** is the input file for the AMC MM code used when only the geometry is to be verified.
- **esl.amc_status** contains status information on the progress of the MM field calculations in AMC. This file is used by Option 3_5 to predict the completion time for the current field calculations.
- **esl.ant** contains data completely describing the current antenna.
- **esl.ellip** contains data specifying the composite ellipsoid used by the UTD code NEWAIR3.
- **esl.fins** contains all the control fin data for the aircraft model.
- **esl.master** contains a list of all the current cross-section files along with their y coordinate values used for the current physical model of the aircraft. This file is generated by Option 1_2.
- **esl.newair_aux** contains data used in creating the UTD NEWAIR3 code input file.
- **esl.newair_errors** contains error statements generated by the operation of the UTD NEWAIR3 code.
- **esl.newair_in** is the input file for the UTD NEWAIR3 code.

APPENDIX C. DATA FILES USED BY THE HARP SYSTEM

- **esl.newair_log** contains key data logged by the UTD code NEWAIR3 as it runs.
- **esl.newair_out** is the NEWAIR3 code's binary output file. It is *not* readable by the user.
- **esl.newair_plot** contains the electromagnetic field data calculated by the UTD code NEWAIR3.
- **esl.phys_body** contains graphics data for the aircraft model body generated by and used by Option 4_1 as well as others. This data is generated each time Option 4_1 is invoked after a new master file has been created by Option 1_2. Thereafter, time is saved by reading this file instead of recalculating the data.
- **esl.rotor** contains all the rotor blade data for the model.
- **esl.towelbar** contains all the towelbar antenna data for the model.
- **harp.plot** is the unixplot output file used for hardcopy output.

All of these files except **esl.newair_out** and **harp.plot** can be viewed with your editor or echoed to the screen with UNIX *pg* or *cat* commands.

Appendix D

HARP Directory Tree

The binaries and source files that make up HARP are located in specific directories which group certain functions together. The top directory, denoted `$HARP_CODES` here, is the site-specific directory where HARP has been installed. All sub-directories of this directory are identical to those listed below at all sites. This complete HARP directory tree and the general function of the code in each of these sub-directories is listed below:

```
$HARP_CODES ... main site HARP directory
| amc_code ... sources for MM executable
|   | predict ... predictor for MM completion
| bin ... all HARP executable binaries
| body_code ... 3D fuselage and attachments
|   | gtd_body ... 3D UTD model
|   | tbar ... towel bar antenna for MM code
| file_io ... major HARP io system
|   | archiver ... file storage and recovery
| gtd_code ... contains only sub-directories
|   | ellipse_code ... UTD ellipse generator
|   | exe_code ... sources for UTD executable
|   | plate_code ... UTD plate generator
|   | prep_code ... UTD input file generator
| lib ... location of HARP libraries
|   | srcs ... sources for the HARP libraries
| menus ... main menu system
```

APPENDIX D. HARP DIRECTORY TREE

- | **mode_geo** ... MM 3D model
- | **plot_code** ... screen plot
 - | **hardcopy** ... paper output
- | **x_sect** ... fuselage cross-section entry

Index

- accuracy, 40, 54, 77
- archive
 - c-reate, 35
 - d-elete, 35
 - h-elp, 34
 - l-ist, 36
 - t-able, 36
 - x-tract, 36
- background job, 15, 69, 70
- bash, 74
- bug, 12, 30, 33
- build master
 - b-uild, 24, 82
 - c-opy, 25, 81
 - d-elete, 27
 - e-xit, 28
 - i-nfo, 26
 - l-ist, 24, 81
 - n-ame, 26
 - r-edraw, 27
 - y-location, 25
- cat, 34
- caveat, 70, 73, 74, 79
- compress, 34
- cpio, 34
- current modes, 63
- derivatives, 55
- dial box, 93
- directory, 8, 11, 12, 30, 73, 74, 76
- distance, 12, 20, 31, 42, 48, 56
- edit fins
 - a-dd, 47
 - d-elete, 46
 - e-xit, 47
 - l-ist, 46
 - m-irror, 47, 83
 - t-oggle, 46
- ellipse, 56–58, 88
- ellipsoid, 14, 55, 56, 58, 60, 87, 88
- executable images, 1, 8, 96
- exit, 11, 12, 30, 32
- expert, 30
- extension, 19, 20, 23–25, 27, 77, 79
- fin
 - active, 46, 47, 54
- fins, 13, 40, 41, 46, 47, 53, 54
- flexibility, 30, 71, 72, 93
- frequency, 13, 48, 54, 55, 64, 69, 70
- function keys, 93
- harp.plot, 73, 74
- HARP_PLOT, 73, 74, 89
- impedance matrix, 65, 69, 70
- iterations, 58

INDEX

limit, 19, 26
linear, 10, 28, 50

master file, 10, 13, 17, 24, 28, 80
monopole, 41

novice, 30, 31

origin, 80

pg, 34
plates, 53
polarization, 71, 72
polygon, 53
postscript, 72-74, 89
pwd, 30, 73

rotor blades, 13, 40, 41, 49-51, 53

shell, 12, 27, 32, 73
sides, 47, 53, 54
silhouette, 10, 17, 28
summary page, 37

tablet, 2, 10, 12, 17, 20, 27, 42, 47,
50
tag, 44
tilt, 41, 53
towelbar, 60
translucent, 14, 60

warning, 26, 29, 53, 60, 87
wires, 53

zero, 20