

N93-31558



PROGRESS IN THE MEASUREMENT OF SSME TURBINE HEAT FLUX WITH PLUG-TYPE SENSORS

Curt H. Liebert
NASA Lewis Research Center
Cleveland, Ohio 44135

71-35
11-100

Data reduction has been completed for tests of plug-type heat flux sensors (gauges) in a turbine blade thermal cycling tester (TBT). This TBT is located at NASA/Marshall Space Flight Center. A typical gauge is illustrated in figure 1. These tests were discussed last year at the 1990 Advanced Earth-to-Orbit Propulsion Technology Conference. This is the first time heat flux has been measured in a space shuttle main engine (SSME) turbopump turbine environment. The tests were highly successful.

The development of the concept for the gauge was done in a heat flux measurement facility located at Lewis. This facility was described at the 1987 Structural Integrity and Durability of Reusable Space Propulsion Systems Conference. In this facility, transient and steady state absorbed surface heat flux information was obtained from transient temperature measurements taken at points within the gauge. Figure 2 shows a gauge that has been placed at the external focus of an elliptical reflector in a lamp head attached to the side of a service module in the lamp system. A 100-kW Vortek arc lamp is used as a source of transient and steady state thermal radiant energy which impinges onto the active surfaces of heat flux gauges.

A schematic of the TBT is presented in figure 3. Three test blades with gauges built into their airfoils were located in position B of figure 3. On the upper blade, the active surface of the gauge is positioned on the airfoil pressure surface at midspan and midchord. Another gauge is mounted on the suction surface of the middle blade at the throat between the airfoil root and midspan. The gauge on the lower airfoil is positioned on the suction surface at midspan and midchord. The TBT was operated for 2½ cycles for a total test time of 48 seconds. A ruptured seal on a TBT component caused shutdown prior to the usual 5 cycle test series.

Plots of the absorbed surface heat flux measured on the three blades tested in the TBT are shown in figure 4. The uncertainty in the measurements is believed to be 7 to 30 percent (ref. 1). In general, the heat fluxes measured on all three blades followed nearly the same transient and quasi-steady state energy pattern. During startup, the transient heat flux varied irregularly as TBT gas pressure and temperature fluctuated through rapidly varying transients. After startup, the TBT operated at quasi-steady combustion conditions resulting in a smooth decrease in heat flux as the gauges and blades reached thermal equilibrium with their quasi-steady hot gas surroundings. The sign of the heat flux measured during this startup and quasi-steady portion of the cycle was positive which signifies that heat is being gained (absorbed) by the blades. Maximum temperatures achieved by the gauges were about 1460 K (2180 °F) as the blades approached equilibrium conditions with their hot surroundings. At this maximum temperature, measured heat flux was about 0.17 MW/m². This is about the lowest absolute value of heat flux that can be meaningfully measured with these gauges in the TBT. Negative values of tran-

[REDACTED]

sient heat flux (fig. 4) were generally obtained during the cooling part of the cycle when combustion is stopped and then very cold gas is admitted to the TBT. These negative values indicate that heat is being lost from the active surface of the gauge. The lowest temperatures measured with the gauges was about 93 K (-293 °F).

The solid line in figure 4 passes through the center blade heat flux data and is the most representative of the SSME turbopump turbine conditions. Center blade peak heat fluxes were measured as 14 and -14.7 MW/m² at maximum heating and cooling conditions. These values are in reasonable agreement with SSME design calculations. High quality heat flux values were measured on all three blades. The experiments demonstrated that reliable and durable gauges can be repeatedly fabricated into the airfoils. The experimental heat flux data are being used for verification of SSME analytical stress, boundary layer, and heat transfer design models. The measured heat flux of 14 MW/m² is 50 to 100 times those encountered in aircraft engines.

Future efforts include plans for using these gauges for absorbed surface heat flux measurement in SSME testbed engine turbopump nozzles at Marshall. Figure 5 shows a rear view of a plug gauge mounted into an SSME vane airfoil for heat flux measurement on the pressure surface. Figure 5 also shows a nozzle segment from which a vane was cut for mounting and testing in the heat flux measurement facility at Lewis. The heat flux tests demonstrated that the gauge was of high quality.

Research is continuing on the development of a rational basis for steady state and transient calibration of heat flux sensors. This research involves round robin tests with Pratt & Whitney and Case Western Reserve University. For this round robin, four gauges are being fabricated at Lewis. Each gauge is first being tested in the Lewis facility. Figure 6 shows some representative data obtained at low arc lamp input currents. Agreement of this data with the data taken with commercial Hi-Cal gauges is satisfactory. These measurements were obtained at the lower limit of arc lamp energy output thus demonstrating that heat fluxes can be satisfactorily measured for several seconds at lower levels of quasi-steady heating (and cooling) conditions such as occurred in the TBT.

Finally, these gauges are being considered for radial turbine rotor, advanced short takeoff and vertical landing aircraft research and for thin film heat flux gauge and thin film thermocouple experiments at Lewis.

REFERENCES:

1. Liebert, C. H.: Heat Flux Measurement in SSME Turbine Blade Tester. NASA TM-103274, 1990.

Plug Heat Flux Gage

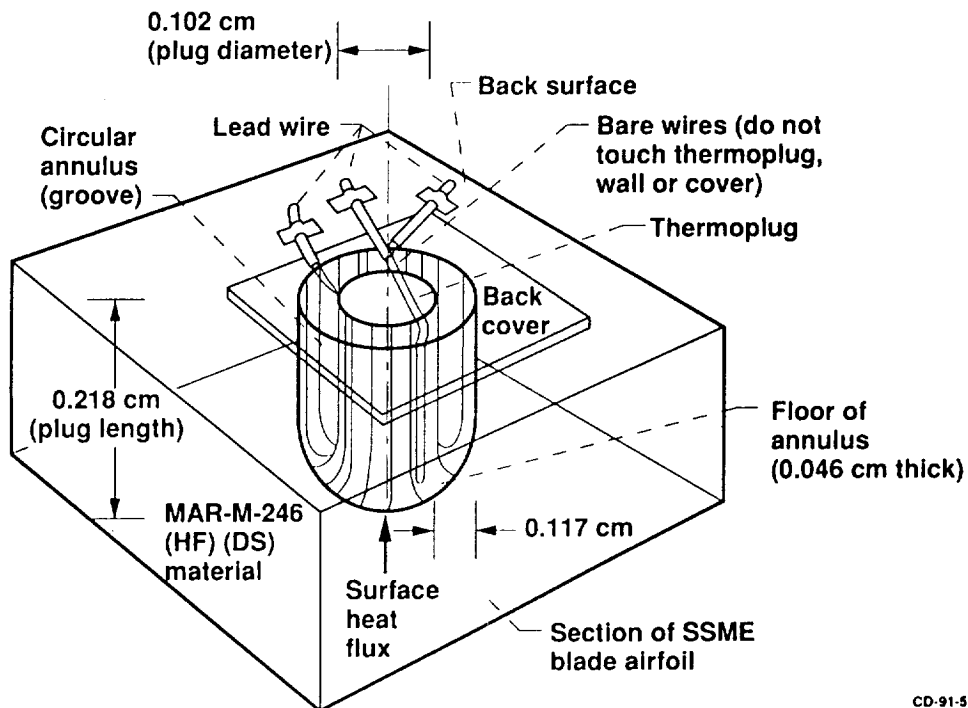

Figure 1

Lamphead and Positioning Arm

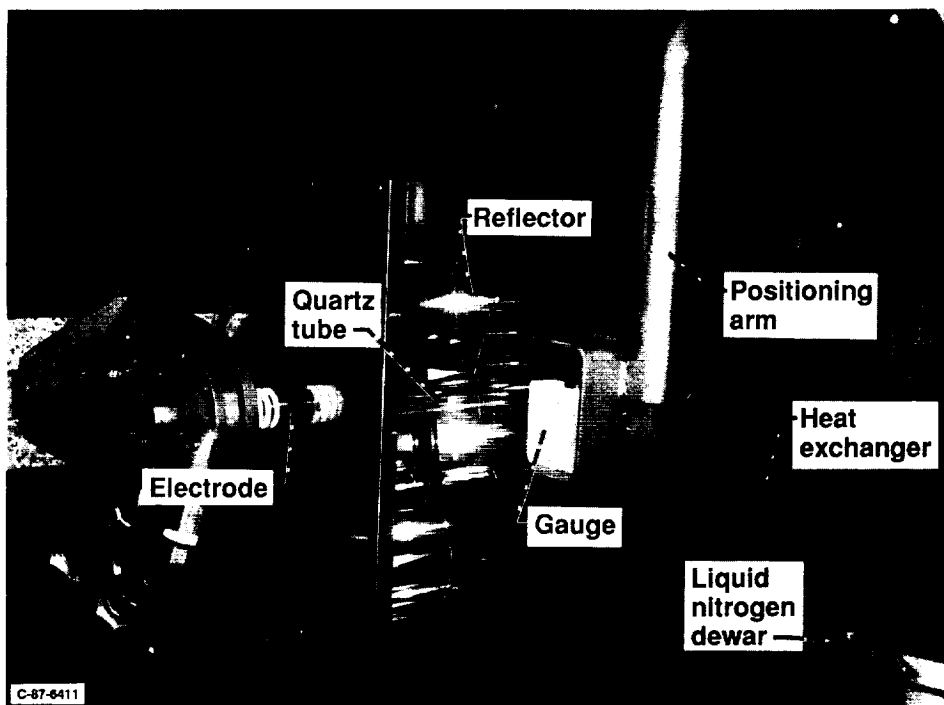

Figure 2

Plug Gauge in SSME Nozzle Vane

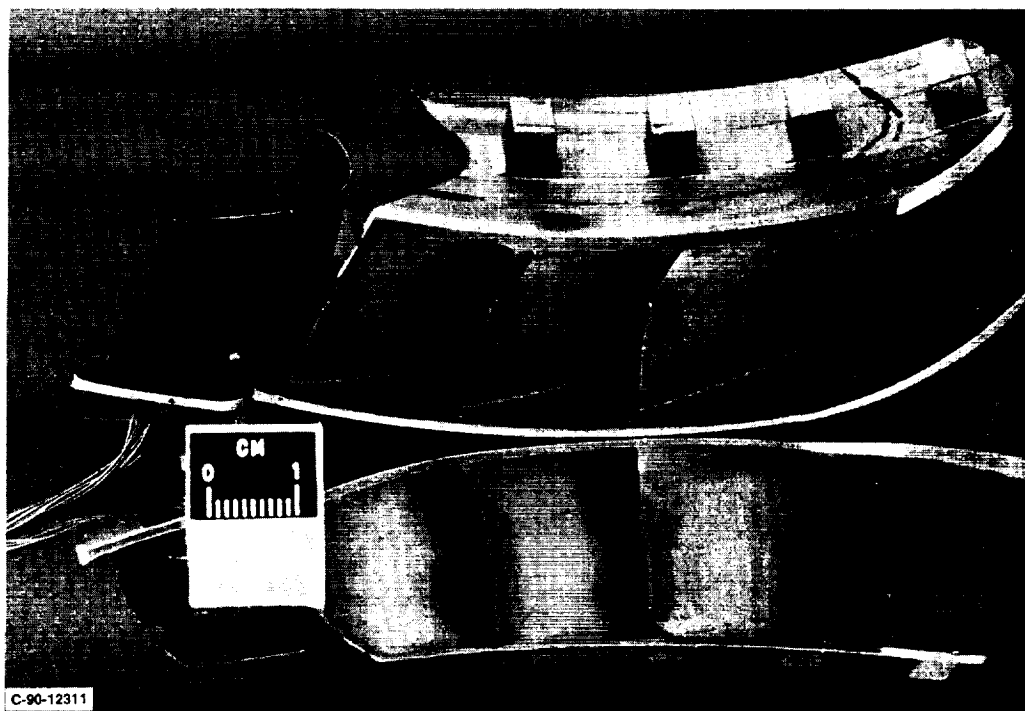
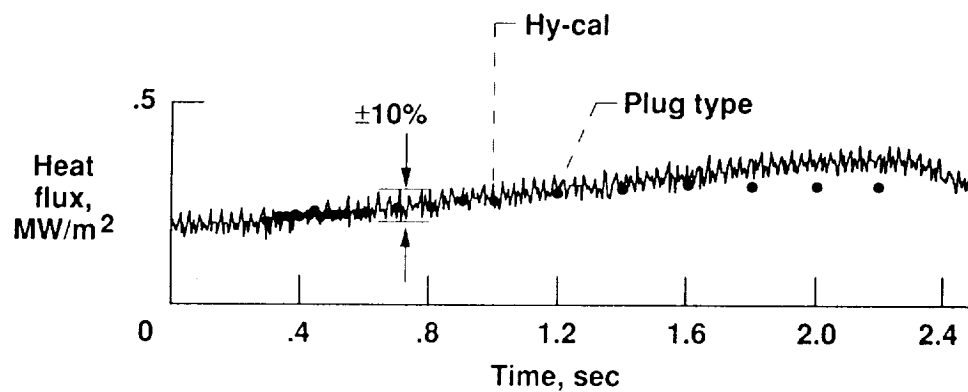

Figure 5

ORIGINAL PAGE
BLACK AND WHITE PHOTOGRAPH

Heat Flux Measurements on Three Blades



CD-91-52054

Figure 6

