

NASA Technical Memorandum 106041

Noise Trends of a 0.5-m- (20-in.-) Diameter Supersonic Throughflow Fan as Measured in an Unmodified Compressor Aerodynamic Test Facility

James H. Dittmar
*Lewis Research Center
Cleveland, Ohio*

David G. Hall
*Sverdrup Technology, Inc.
Lewis Research Center Group
Brook Park, Ohio*

and

Royce D. Moore
*Lewis Research Center
Cleveland, Ohio*

Restriction changed to Unclassified/Unlimited per
DAA modified May 19, 2006, by authority of the
NASA Glenn Research Center, Programs and Projects
Directorate Office.

LIMITED DISTRIBUTION DOCUMENT

~~Because of its significant technological potential, this information which has been developed under a U.S. Government program is being given a limited distribution whereby advanced access is provided for use by domestic interests. This legend shall be marked on any reproduction of this information in whole or in part.~~

April 1993

Date for general release April 1998



NOISE TRENDS OF A 0.5-m- (20-in.-) DIAMETER SUPERSONIC THROUGHFLOW FAN AS MEASURED IN AN UNMODIFIED COMPRESSOR AERODYNAMIC TEST FACILITY

James H. Dittmar
National Aeronautics and Space Administration
Lewis Research Center
Cleveland, Ohio 44135

David G. Hall
Sverdrup Technology, Inc.
Lewis Research Center Group
Brook Park, Ohio 44142

and

Royce D. Moore
National Aeronautics and Space Administration
Lewis Research Center
Cleveland, Ohio 44135

SUMMARY

The tone noise levels of a supersonic throughflow fan were measured at subsonic and supersonic axial duct Mach numbers. The noise in the inlet plenum showed no blade passing and harmonic tones at subsonic or supersonic axial flow conditions. At subsonic axial flow conditions, the supersonic throughflow fan showed no inlet plenum tones at fan operating conditions where tone noise had been previously measured for a subsonic fan design. This lower inlet-quadrant noise level for the supersonic throughflow fan was the result of high subsonic inlet velocities acting to reduce the noise propagating out the inlet. The fan noise, which was prevented from propagating upstream by the high subsonic inlet velocities, appeared to increase the noise in the exhaust duct at subsonic throughflow conditions. The exhaust duct noise decreased at supersonic axial throughflow Mach numbers, with the lowest blade passing and harmonic tones levels being observed at the design axial Mach number of 2.0. Multiple pure tone noise was observed in the inlet duct at subsonic axial flow Mach numbers but was seen only in the exhaust duct at supersonic axial flow conditions.

INTRODUCTION

Various propulsion systems have been considered to power the next generation of commercial supersonic transports (refs. 1 to 5). Of the several cycle concepts investigated, a cycle including a supersonic throughflow fan was shown to have a significant advantage (ref. 6). The NASA Lewis Research Center has an ongoing program to design, build, and test a fan stage that has supersonic axial velocities from inlet to exit. The design of such a fan is described in reference 7, and the aerodynamic testing of such a fan is reported in references 8 and 9.

Because the noise of the next generation of supersonic airplanes might represent a barrier to their acceptance (ref. 10), some preliminary noise measurements were made on a supersonic

throughflow fan stage. These measurements were made in an unmodified, hard-walled, compressor aerodynamic test facility. The noise trends observed during this testing are presented in this report.

APPARATUS AND PROCEDURE

Supersonic Throughflow Fan

References 7 to 9 describe the fan details; only a brief description is included here. The fan rotor (fig. 1) has 44 blades, and the fan stator (fig. 2) has 52 vanes. The rotor-stator interaction tone is, therefore, "cut on" in the duct (i.e., it does not decay exponentially as it passes down the duct). The design tip speed is 457 m/sec (1500 ft/sec), so the rotor-only tones are cut on at 72 percent of design speed and above. The inlet strut wake-rotor interaction is also cut on. The overall design parameters for the stage are given in table I.

Test Facility and Acoustic Instrumentation

A schematic and photograph of the fan test facility are shown in figure 3. The laboratory central air system provides dry air for the facility. The air enters the inlet plenum, then passes through the fan test package and through the collector where it is removed by the laboratory altitude exhaust system. A photograph of the supersonic throughflow fan test package and a sketch of its incorporation in the facility are shown in figure 4.

Pressure transducers were installed in the plenum chamber, on the outer wall of the test package, and in the altitude exhaust collector. Figure 5 shows the location of the transducers in the facility. The transducer (A) installed in the plenum chamber upstream of fan test package, was located 40.6 cm (16 in.) from the outside wall. This location was used in a similar plenum chamber to obtain reverberant room noise levels for some subsonic fans (refs. 11 and 12). An inlet transducer (B) was installed flush with the outer wall in the fan inlet duct upstream of the rotor. This transducer was between the variable nozzle and the rotor when the fan was operated subsonically. Another transducer (C) was installed flush with the outer wall at a location halfway between the rotor trailing edge and the stator leading edge. A downstream transducer (D) was installed behind the stator trailing edge, and the final transducer (E) was installed in the collector outer wall. These locations are shown in figure 5.

The noise signals from these pressure transducers were recorded on magnetic tape for off-line analysis. The noise from all of the test conditions was analyzed and converted to narrowband spectra with a range of 0 to 40 000 Hz and a bandwidth of 128 Hz. For those conditions where the blade passing frequency was below 10 000 Hz, the data were also converted to spectra with a 0 to 10 000 Hz range and a 32-Hz bandwidth. In addition, some specific conditions, as described later, were analyzed with zoom spectral techniques (400-Hz range centered on a tone frequency) to improve the tone-level to background-noise ratio.

Operating Conditions

Acoustical data were taken with the fan operating at the 12 conditions shown in figure 6. This plot, which was taken from reference 9, shows the fan pressure ratio plotted against the fan inlet Mach number. A description of each of the test conditions follows:

Condition I—This test point is at 40 percent fan speed with a fan inlet axial Mach number of 0.47. At this low speed, the axial flow through the entire device is subsonic.

Condition II—This test point is at 50 percent fan speed with a fan inlet axial Mach number of 0.53. The axial flow is subsonic through the entire device.

Condition III—This test point is at 60 percent fan speed with a fan inlet axial Mach number of 0.61. The axial flow is subsonic through the entire device.

Condition IV—This test point is at 75 percent fan speed with a fan inlet axial Mach number of 0.82. At this condition, the fan has relative supersonic flow near the tip and has a transonic fan, but all of the axial flows in the device are subsonic.

Condition V—This test point is at 75 percent fan speed with a fan inlet axial Mach number of 0.83. Here the rotor has axial supersonic flow inside the rotor passage but is subsonic elsewhere in the fan.

Condition VI—This test point is at 75 percent fan speed with a fan inlet axial Mach number of approximately 0.83. The flow at this condition is axially supersonic inside the rotor and the stator but subsonic in front of the rotor and behind the stator. Note that the pressure ratio has gone up from condition V when the supersonic flow extends through the stator.

Condition VII—This test point is at 75 percent fan speed with a fan inlet axial Mach number (downstream of the nozzle) of 0.84. This is roughly the same operating condition as condition VI, but the inlet variable nozzle has been moved to form supersonic flow in the nozzle. The flow is then subsonic upstream of the nozzle, supersonic in the nozzle, subsonic between the nozzle and the fan face, supersonic through the rotor and the stator, and subsonic behind the stator.

Condition VIII—This test point is at 75 percent fan speed with a fan inlet axial Mach number of 1.4. The inlet variable nozzle has been moved closer to the fan at this condition, and the flow is axially supersonic from the nozzle downstream throughout the entire fan. This is the first stable supersonic throughflow condition.

Condition IX—This test point is a supersonic throughflow condition at 75 percent fan speed with the design fan inlet axial Mach number of 2.0.

Condition X—This test point is at 100 percent fan speed with a fan inlet axial Mach number of 0.83. This condition is similar to condition VI at 75 percent fan speed, with axially supersonic flow inside the rotor and the stator.

Condition XI—This test point is at 100 percent fan speed with a fan inlet axial Mach number of 1.4. It is the first stable supersonic throughflow test condition at this speed.

Condition XII—This test point is at 100 percent fan speed with a fan inlet axial Mach number of 2.0. It is the design supersonic throughflow condition.

RESULTS AND DISCUSSION

Inlet Plenum Blade Passing Tones

Previous noise measurements in the inlet plenum of a similar test facility showed that this location (A) (fig. 5) could be used to provide reverberant inlet sound power levels for fan stages (ref. 11). Therefore location A was expected to provide similar information for the supersonic throughflow fan. However, no tone noise was observed in the inlet plenum for any of the test conditions. The tone noise levels for the conditions tested are found in table II. Figure 7 is a 0- to 10 000-Hz plot of the sound pressure level in the plenum for condition IV. This test condition is a 75 percent speed point with a pressure ratio of approximately 1.7. At this condition, the blade passing tone should appear at 9500 Hz; and, as can be seen, no tone is visible above the background noise.

These data were compared with the QF-1 fan noise data of reference 11. Fan noise increased significantly with increasing fan speed, and the QF-1 tone noise was only observed above 70 percent speed. The noise of the supersonic throughflow fan would then only be expected above 70 percent speed. The blade passing tone and harmonics were observed for the QF-1 fan operated at 70 percent and higher speeds. Figure 16 of reference 11 shows a 120-dB sound pressure level for the blade passing tone of the QF-1 fan at 70 percent speed on a 20 000-Hz spectrum with a 50-Hz bandwidth. No tone noise was observed for the supersonic throughflow fan in the inlet plenum. A possible reason for the noise not being detected on the supersonic throughflow fan is the high relative background noise level in the supersonic throughflow experiment. The broadband noise level was approximately 100 dB near the tone in the QF-1 experiment, whereas the level seen in figure 7 is approximately 125 dB at the frequency where the tone should appear. The reason for the higher broadband level in the supersonic throughflow experiment is not known at this time. The higher level could be from a noisier facility, self noise from the transducer probe, or higher broadband noise levels from the fan itself. It is unlikely, for reasons that will be discussed later, that the additional broadband noise level is the result of a noisier fan. However, it is not known if the additional noise is from the test facility or the transducer support.

For lowering the broadband-noise to tone-noise ratio, a 400-Hz spectrum, centered on the expected tone frequency was obtained. This spectrum from 9300 to 9700 Hz is shown in figure 8. Here the broadband level is reduced to about 105 dB, but still no tone noise is observed. This figure shows that the tone noise is lower than 105 dB and indicates that the supersonic throughflow fan at 75 percent speed is at least 15 dB quieter than the QF-1 fan at 70 percent speed.

A calculation based on 10 log of the thrust ratio was used to estimate the relative noise levels expected from the two fans. The pressure ratio of the QF-1 fan at 70 percent speed was 1.2, and its hub-to-tip ratio was 0.5. The supersonic throughflow fan had a 1.7 pressure ratio and a 0.7 hub-to-tip ratio. The diameters of the two fans were equal. The thrust was estimated by the change in pressure across the stage multiplied by the annulus area. The result of this calculation was that the supersonic throughflow fan should generate 3.8 dB more noise than the QF-1 fan. The supersonic throughflow fan also had a higher tip speed (457 m/sec (1500 ft/sec) versus 335 m/sec (1100 ft/sec) at design; 342 m/sec (1125 ft/sec) versus 235 m/sec (770 ft/sec) at the compared conditions). According to the prediction methods, these higher tip speeds should make the supersonic throughflow fan even noisier. Despite this prediction, the inlet noise level of the supersonic throughflow fan was at least 15 dB quieter than the QF-1 fan, indicating a

definite inlet noise advantage of the supersonic throughflow fan. The reason for the lower supersonic throughflow fan noise is discussed in the next section.

Inlet Duct Blade Passing Tones

Noise in the inlet duct was measured with a pressure transducer embedded flush in the outer wall at location B (fig. 5). This transducer was not expected to give a reverberant level but only the noise on the outer duct wall. It may indicate the relative noise levels at different conditions, but it will not properly weight the acoustic modes in the duct. For this reason, the total sound power was not accurately represented by the wall measurement. The measurements in the duct may also be biased by pressure fluctuations that do not propagate to the far field as sound. Despite the possible limitations of the measurements on the duct wall, comparisons between the levels at different conditions may provide relative information concerning the supersonic throughflow fan noise.

The 0- to 10 000-Hz noise spectra measured at transducer B for conditions I to IV are shown in figure 9 (data from the 0- to 40 000-Hz spectra are in table II). The blade passing tone can be seen for 40, 50, and 60 percent fan speed (conditions I to III). At condition I the tone is 132 dB, at condition II the tone is 137 dB, and at condition III the tone is 135 dB. The noise first rises with increasing speed, as it should, but then it starts to go back down at condition III. The second harmonic also shows a reduction at condition III (table II). No blade passing tone is visible above the broadband at the 75 percent speed condition (condition IV) nor at any of the other conditions at 75 or higher percent speed.

The reason for the lack of tone is shown in figure 6. As the percent speed was increased, the inlet Mach number increased. As the Mach number was increased, the noise did not propagate as freely out the inlet. Various studies of sonic inlets have shown large noise reductions and have indicated that the Mach number does not have to be 1 or above for the reductions to occur. Reference 13 shows a peak angle reduction in the blade passing tone of over 29 dB at an average throat Mach number of 0.82. This is approximately the same as the Mach numbers encountered here at 75 percent speed. Reference 14 shows a reduction of 17 dB at an inlet Mach number of 0.8 and a 15 dB reduction at a Mach number of 0.7. Condition III at 60 percent speed had an inlet Mach number of approximately 0.7. The high inlet Mach numbers of the supersonic throughflow fan caused the tone noise generated by the fan to be attenuated as it went out the inlet. The supersonic throughflow fan should generate more noise than a transonic fan like QF-1, but the high subsonic inlet Mach numbers of the supersonic throughflow fan attenuated this noise and resulted in lower inlet noise levels.

Reference 13 shows approximately the same broadband noise level reductions at frequencies near the tone as does the tone itself. If we assume that this would be the case here, then if the tone is visible above the fan broadband-noise at condition III in the duct then it should be visible above the fan broadband noise in the plenum. For this reason it is unlikely that the high broadband-noise level in the inlet plenum is from the fan itself.

Blade Passing Tone Levels Behind the Fan

The noise levels behind the fan were measured with a transducer embedded flush with the outside wall at position D. Like the transducer at location B, this transducer was not expected to give a reverberant level but only the noise on the outer duct wall. The transducer may

indicate the relative noise levels at different conditions, but it will not properly weight the acoustic modes in the duct. For this reason the total sound power was not accurately represented by the wall measurement. The hard wall measured levels would also be 6 dB above the free field level. The measurements in the duct may also be biased by pressure fluctuations that do not propagate to the far field as sound. Despite the possible limitations of the measurements on the duct wall, comparisons between the levels at different conditions may provide relative information concerning the supersonic throughflow fan noise.

Comparisons of the in-duct noise levels in front of the fan (position B) and behind the fan (position D) seen in table II indicate that the noise levels behind the fan are much larger than those in the inlet. If we assume that these wall measurements are indicative of the relative sound power levels, the supersonic throughflow fan will be aft noise dominant.

The behavior of the noise behind the fan also indicates what happens to the noise that was prevented from propagating upstream by the high inlet flow velocities. This can be seen in table II. As the fan inlet flow Mach number increased, the noise was prevented from going upstream. This can be seen strongly between conditions III and IV where the noise in the inlet dropped below the broadband level. In the downstream location (position D), the blade passing tone noise took a sharp rise—going from 148 dB at condition III to 163 dB at condition IV. This is a much larger rise than would be expected, but it indicates that some of the noise that was prevented from going upstream has been convected downstream through the fan adding to the aft noise dominance of the supersonic throughflow fan. This behavior is also seen in the harmonic noise levels where the tone has increased at condition IV.

The increased tone level in the aft duct also existed at condition V where the flow was supersonic through the rotor but was subsonic through the stator. As can be seen in table II, conditions IV and V were the only two conditions where the blade passing tone was observed in the collector (position E). Tones were not observed above the broadband level at other conditions at position E because the collector tone levels were lower than the position D levels as a result of the larger flow area and because the broadband levels were higher. For example, the broadband level near the tone for condition III was approximately 130 dB at position D but was approximately 140 dB at position E.

The noise level at position D went back down again at condition VI where the flow was axially supersonic through both the rotor and the stator. The noise stayed down at the lower levels for the rest of the 75 percent speed conditions where the flow was supersonic through the fan. The physical mechanism for this lower noise is not known. It may be the result of attenuation as it passes downstream through the stators where the flow is supersonic, or it may be that when the stator has supersonic flow it no longer generates as much noise from the interaction with the rotor wakes and vortexes. There also might be some reason why the transducer measured less of the noise power at this condition than it did previously. Whatever the reason, the measured blade passing tone and harmonics noise levels at the conditions where the stator had supersonic throughflow were back down to the low-speed levels. When the fan was operated at its design throughflow Mach number (2.0) at 75 percent speed (condition IX), the tone noise dropped even further. The blade passing tone at condition IX was 138 dB, approximately the same as the inlet duct noise level that existed at 50 percent speed (condition II) and over 20 dB lower than at the peak exhaust level of condition V. It should be further cautioned here that the accuracy of noise measurements on a wall inside a boundary layer with supersonic free stream flow has not been verified. If, however, the far field sound power levels were behaving similarly to these duct wall levels, the supersonic throughflow fan would be a relatively quiet device at the design throughflow Mach number at 75 percent speed.

The trend at 100 percent speed is not quite as clear. Here the blade passing noise at condition XII (design condition) was about the same as the first stable supersonic condition (condition XI) and did not show the 10 dB drop that existed between the first stable supersonic condition at 75 percent speed (condition VIII) and the design Mach number condition at 75 percent speed (condition IX). The drop was observed at two and three times the blade passing frequency. The blade passing tone at condition XII was, however, down to 140 dB. These levels are almost the same as those for condition IX (the design Mach number condition at 75 percent speed), which indicates that the design point at 100 percent speed was also a relatively quiet condition.

Blade Passing Tone Levels Between the Rotor and Stator

The noise levels between the rotor and stator were measured with a transducer embedded flush with the outside duct wall at position C. Like the transducers at locations B and D, this transducer was not expected to give a reverberant level but only the noise on the outer duct wall. The transducer may indicate the relative noise levels at different conditions, but it will not properly weight the acoustic modes in the duct. For this reason, the total sound power was not accurately represented by the wall measurement. The hard wall measured levels would also be 6 dB above the free field level. The measurements in the duct may also be biased by pressure fluctuations that do not propagate to the far field as sound. This measurement of pressure fluctuations may be worse here between the rotor and the stator because of the proximity of the transducer to the blade rows. Despite the possible limitations of the measurements on the duct wall, comparisons between the levels at different conditions may provide relative information concerning the supersonic throughflow fan noise.

The behavior of the noise between the blade rows is not as clearly explainable as that upstream and downstream of the fan, but some trends are observed. The tone noise began to increase as the speed was increased (conditions I to II). The noise was assumed to come from the rotor-stator interaction and was expected to increase with speed. The noise, however, started to go down from conditions II to IV. Here again, the high axial Mach numbers began to impede the noise generated on the stators from going upstream to the transducer. The noise then went back up in level at condition V. This is the condition where the rotor first had supersonic axial flow. The increase in level combined with the fact that the rotor-only and strut-rotor interaction tones propagate at this condition may indicate that this is rotor-only noise, which previously went upstream, but is now convected downstream to transducer position C. It also may be that, with the supersonic flow in the rotor, the generated noise was now louder both from the rotor-only and the rotor-stator interaction mechanisms.

When the supersonic throughflow fan achieved stable supersonic axial flow through the entire device (condition VIII), the noise went down. This phenomenon may indicate that less noise was being generated. The condition of 75 percent fan speed with an axial Mach number of 2.0 (condition IX) produced the lowest noise measured between the blades. This condition also produced the lowest noise measured in the aft position (D) and further indicates that the far field noise at this condition may be low. The same general behavior can be seen in the 100 percent fan speed data, where condition XII, the design condition, had the least noise.

Multiple Pure Tone Behavior

Multiple pure tones, tones at shaft passing frequency and harmonics, started to form at the first 75 percent speed point (condition IV). Figure 10 shows their presence at position B in front of the rotor and at position C between the rotor and stator. Few, if any, multiple pure tones are seen at position D behind the stator. As discussed previously, the blade passing tone was missing from the position B spectrum at this condition because of the high inlet Mach number. Here, in comparing position C and B spectra, the sound pressure level of the multiple pure tone activity has been decreased, but it is still present in the inlet (position B). The multiple pure tones appear to be more persistent in moving upstream in the high subsonic Mach number flow than are the blade passing tones. The multiple pure tones also appear to be controlling the inlet noise level in the duct. No multiple pure tones were observed in the inlet plenum (position A) at any of the conditions tested.

Multiple pure tones were observed in the inlet duct (position B) until the axial flow in the duct became supersonic. Figure 11 shows the data at the first supersonic throughflow condition (condition VIII). No multiple pure tones were observed in the inlet duct at position B, even when strong, multiple pure tone activity was observed at position C between the rotor and stator.

Strong, multiple pure tone activity was observed in the duct aft of the stators (position D) (fig. 11(c)). This activity is assumed to be a result of the multiple pure tones that were traveling upstream, being swept downstream by the supersonic axial flow. This large amount of multiple pure tone activity in the aft duct, while none is seen in the inlet, is a unique feature of the supersonic throughflow fan. This phenomenon is not observed with a subsonic axial flow fan. This large amount of multiple pure tone activity in the aft duct would contribute significantly to the total fan noise.

CONCLUDING REMARKS

The noise levels of a supersonic throughflow fan were measured at subsonic and supersonic axial duct Mach numbers in a compressor test facility. The noise was measured with transducers located (1) in an inlet plenum (approximately a reverberant environment), (2) on the outside duct wall (with locations in front of the rotor, between the rotor and stator, and downstream of the stator), and (3) in an exhaust collector. The measurements on the outer duct wall and in the collector do not represent reverberant levels and only indicate the level on the wall. The duct wall measurements do not measure the sound power level and are only used here to indicate the relative noise behavior. Also, not all of the pressure fluctuation measurements on the duct walls represent acoustic levels that would propagate to the far field. Therefore, the measurements on the wall are not conclusive proof of the overall behavior but only give relative indications of the fan noise behavior.

No tone noise, at subsonic or supersonic conditions, was visible above the broadband levels in the inlet plenum despite the fact that tones were measured in a similar facility for a conventional subsonic fan. This indicated that the supersonic throughflow fan is quieter, in the inlet quadrant, than a subsonic fan even though the supersonic throughflow fan should have produced more noise. The apparent reason for this is that the high inlet Mach numbers in the supersonic throughflow fan, even at subsonic conditions, reduce the amount of the noise that propagates upstream.

The transducer on the inlet duct wall only showed blade passing and harmonic tones through the 60 percent fan speed condition. At 75 percent and higher fan speeds, no blade passing or harmonic tone noise was visible in the inlet duct. At the 75 percent fan speed, the axial inlet duct Mach number was 0.82, a level that has been previously shown to significantly reduce the noise propagating upstream.

The tone noise measured in the exhaust duct behind the stator increased when the noise level was reduced in the inlet. In other words, the noise that would have propagated out the inlet was apparently convected downstream out the exhaust. The increased tone noise in the aft duct continued for the various test conditions until supersonic axial velocities were achieved throughout the entire fan stage. Then the tone noise in the aft duct decreased, and the lowest exhaust blade passing tone levels were achieved at the design axial throughflow Mach number of 2.0. Here the exhaust tone noise, which was over 20 dB less than that measured at the peak noise condition, indicates that the design Mach number of 2.0 is the condition to operate the fan for the least fan noise.

Multiple pure tones were visible in the inlet duct spectra when the fan relative speed at the tip exceeded the speed of sound. These multiple pure tones diminished in passing upstream against the high subsonic inlet Mach number flow but were not reduced as much as were the blade passing tones. The multiple pure tones were not seen in the inlet duct for supersonic axial flow velocities but were observed in the exhaust duct at these conditions.

This report provides some insight into the noise generated by a supersonic throughflow fan. It does not, however, give accurate indications of the sound power level. Therefore, to completely access supersonic throughflow fan noise, it will be necessary to perform an experiment in an acoustic facility where far field noise levels can be obtained.

REFERENCES

1. Smith, M.G., Jr.: 21st Century High Speed Transport Propulsion. AIAA Paper 88-2987, July 1988.
2. Trucco, H.: Study of Variable Cycle Engines Equipped With Supersonic Fans. (ATL TR-201, Advanced Technology Labs.; NASA Contract NAS3-17559), NASA CR-134777, 1975.
3. Mclean, F.E.: Supersonic Cruise Technology. NASA SP-472, 1985.
4. Calder, P.H.; and Gutpa, P.C.: Engine Options for Supersonic Cruise Aircraft. AIAA Paper 78-1054, July 1978.
5. Howlett, R.A.; and Smith, M.G., Jr.: Advanced Supersonic Transport Propulsion Systems. SAE Paper 771010, Nov. 1977.
6. Franciscus, L.C.: The Supersonic Through-Flow Turbofan for High Mach Propulsion. AIAA Paper 87-2050, June 1987. (Also NASA TM-100114, 1987.)
7. Schmidt, J.F., et al.: Supersonic Through Flow Fan Design. AIAA Paper 87-1746, June 1987. (Also NASA TM-88908, 1987.)

8. Moore, R.D.; and Tweedt, D.L.: Aerodynamic Performance of a Supersonic Throughflow Fan Rotor. NASA TP-3115, 1991.
9. Moore, R.D.; Schmidt, J.F.; and Tweedt, D.L.: Aerodynamic Performance of a Supersonic Throughflow Fan Stage. NASA TP-3308, 1993.
10. Smith, M.J.T., et al.: Future Supersonic Transport Noise—Lessons from the Past. AIAA Paper 88-2989, July 1988.
11. Gelder T.F.; and Soltis, R.F.: Inlet Noise of 0.5-Meter-Diameter NASA QF-1 Fan As Measured in an Unmodified Compressor Aerodynamic Test Facility and in an Anechoic Chamber. NASA TN D-8121, 1975.
12. Gelder T.F.; and Soltis, R.F.: Inlet Plenum Chamber Noise Measurement Comparison of 20-Inch Diameter Fan Rotors With Aspect Ratios 3.6 and 6.6. NASA TM X-2191, 1971.
13. Miller, B.A.; and Abbott, J.M.: Aerodynamic and Acoustic Performance of Two ChokedFlow Inlets Under Static Conditions. NASA TMX-2629, 1972.
14. Study and Development of Turbofan Nacelle Modifications to Minimize Fan-Compressor Noise Radiation. Vol. 5—Sonic Inlet Development. NASA CR-1715, 1971.

TABLE I.—OVERALL SUPERSONIC THROUGHFLOW
FAN DESIGN CONDITIONS

Blade number	
Rotor	44
Stator	52
Pressure ratio	2.45
Tip speed, m/sec (ft/sec)	457 (1500)
Inlet axial Mach number	2.0
Diameter, cm (in.)	50.8 (20)
Hub-tip ratio	0.7

TABLE II.—TONE LEVELS
[Sound pressure level, dB ref. 2×10^{-5} N/m²]
(a) At blade passing frequency.

Test condition	Percent of design speed	Inlet axial Mach number	Transducer position					Comments
			A	B	C	D	E	
I	40	0.47	(a)	132	146	156	(a)	Supersonic flow in rotor passages; subsonic elsewhere
II	50	.53	↓	138	156	150	(a)	
III	60	.61	↓	135	153	148	(a)	
IV	75	.82	↓	(a)	149	163	149	
V	↓	.83	↓	↓	155	165	148	
VI	↓	.83	↓	↓	154	148	(a)	
VII	↓	.84	↓	↓	154	148	↓	
VIII	↓	1.4	↓	↓	148	148	↓	
IX	↓	2.0	↓	↓	139	138	↓	
X	100	.83	↓	↓	149	(b)	↓	
XI	100	1.4	↓	↓	153	139	↓	
XII	100	2.0	↓	↓	138	140	↓	

^aNo tones visible above broadband (see text for discussion).

^bTransducer not functioning.

TABLE II.—Continued.
(b) At twice blade passing frequency.

Test condition	Percent of design speed	Inlet axial Mach number	Transducer position					Comments
			A	B	C	D	E	
I	40	0.47	(a)	139	145	139	(a)	Supersonic flow in rotor passages; subsonic elsewhere Supersonic flow in rotor and stator; subsonic elsewhere Supersonic flow in rotor, stator, and inside inlet nozzle; subsonic elsewhere Supersonic flow in rotor and stator; subsonic elsewhere
II	50	.53	↓	131	151	144	↓	
III	60	.61	↓	(a)	151	147	↓	
IV	75	.82	↓	↓	149	150	↓	
V	↓	.83	↓	↓	143	153	↓	
VI	↓	.83	↓	↓	149	142	↓	
VII	↓	.84	↓	↓	148	141	↓	
VIII	↓	1.4	↓	↓	148	140	↓	
IX	↓	2.0	↓	↓	148	131	↓	
X	100	.83	↓	↓	151	(b)	↓	
XI	100	1.4	↓	↓	155	143	↓	
XII	100	2.0	↓	↓	146	132	↓	

^aNo tones visible above broadband (see text for discussion).

^bTransducer not functioning.

TABLE II.—Continued.
(c) At three times blade passing frequency.

Test condition	Percent of design speed	Inlet axial Mach number	Transducer position					Comments
			A	B	C	D	E	
I	40	0.47	(a)	125	138	141	(a)	Supersonic flow in rotor passages; subsonic elsewhere Supersonic flow in rotor and stator; subsonic elsewhere Supersonic flow in rotor, stator, and inside inlet nozzle; subsonic elsewhere Supersonic flow in rotor and stator; subsonic elsewhere
II	50	.53		(a)	143	140		
III	60	.61			138	139		
IV	75	.82			135	144		
V		.83			149	146		
VI		.83			140	144		
VII		.84			140	143		
VIII		1.4			145	143		
IX		2.0			141	123		
X	100	.83			149	(b)		
XI	100	1.4			148	143		
XII	100	2.0			136	132		

^aNo tones visible above broadband (see text for discussion).

^bTransducer not functioning.

TABLE II.—Concluded.
(d) At four times blade passing frequency.

Test condition	Percent of design speed	Inlet axial Mach number	Transducer position					Comments
			A	B	C	D	E	
I	40	0.47	(a)	(a)	130	132	(a)	Supersonic flow in rotor passages; subsonic elsewhere Supersonic flow in rotor and stator; subsonic elsewhere Supersonic flow in rotor, stator, and inside inlet nozzle; subsonic elsewhere Supersonic flow in rotor and stator; subsonic elsewhere
II	50	.53	↓	↓	145	138	↓	
III	60	.61	↓	↓	147	135	↓	
IV	75	.82	↓	↓	133	(a)	↓	
V	↓	.83	↓	↓	140	142	↓	
VI	↓	.83	↓	↓	139	138	↓	
VII	↓	.84	↓	↓	138	138	↓	
VIII	↓	1.4	↓	↓	141	136	↓	
IX	↓	2.0	↓	↓	139	130	↓	
X	100	.83	↓	↓	(c)	(b)	(c)	
XI	100	1.4	↓	↓	(c)	(c)	(c)	
XII	100	2.0	↓	↓	(c)	(c)	(c)	

^aNo tones visible above broadband (see text for discussion).

^bTransducer not functioning.

^cTone frequency higher than range analyzed.

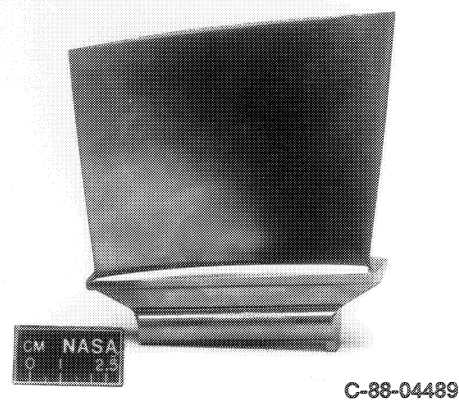
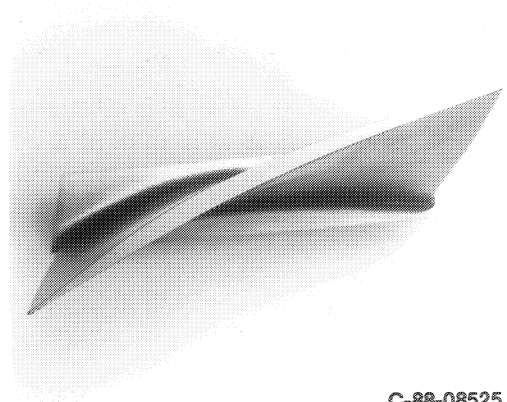
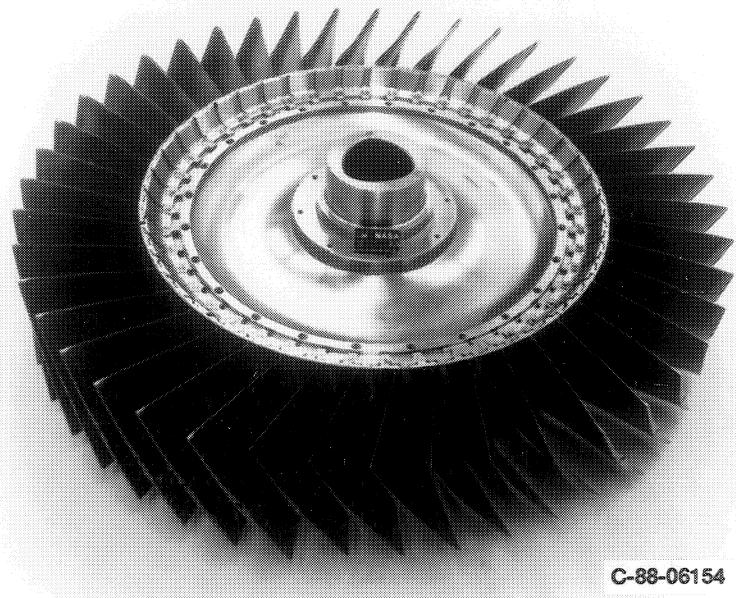

Figure 1.—Supersonic throughflow fan rotor.

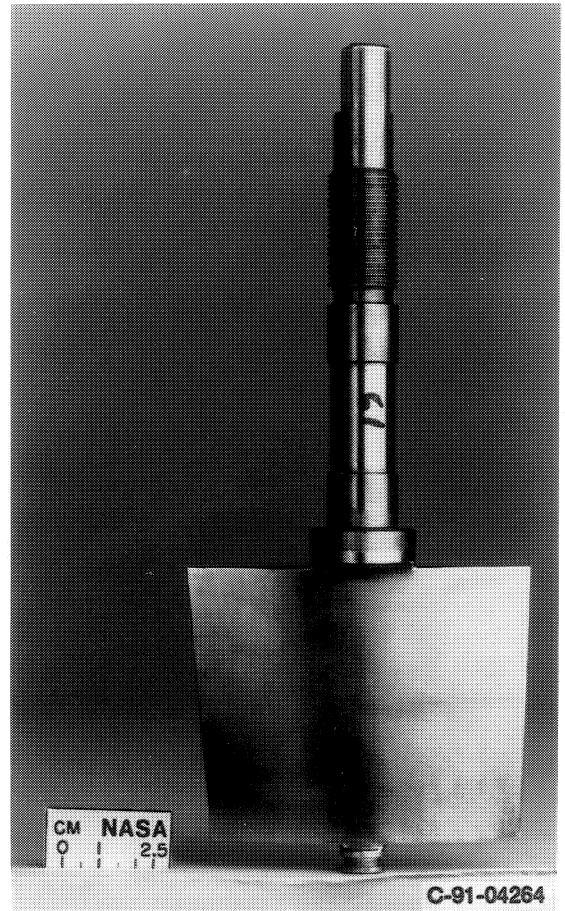
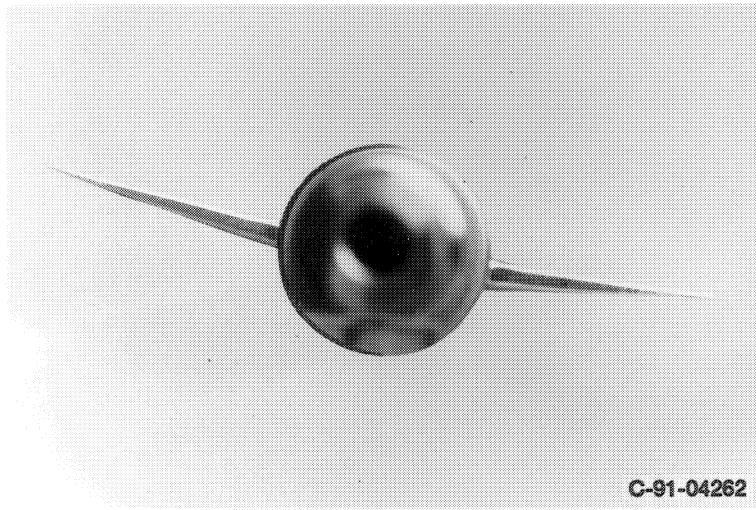

Figure 2.—Supersonic throughflow fan stator.

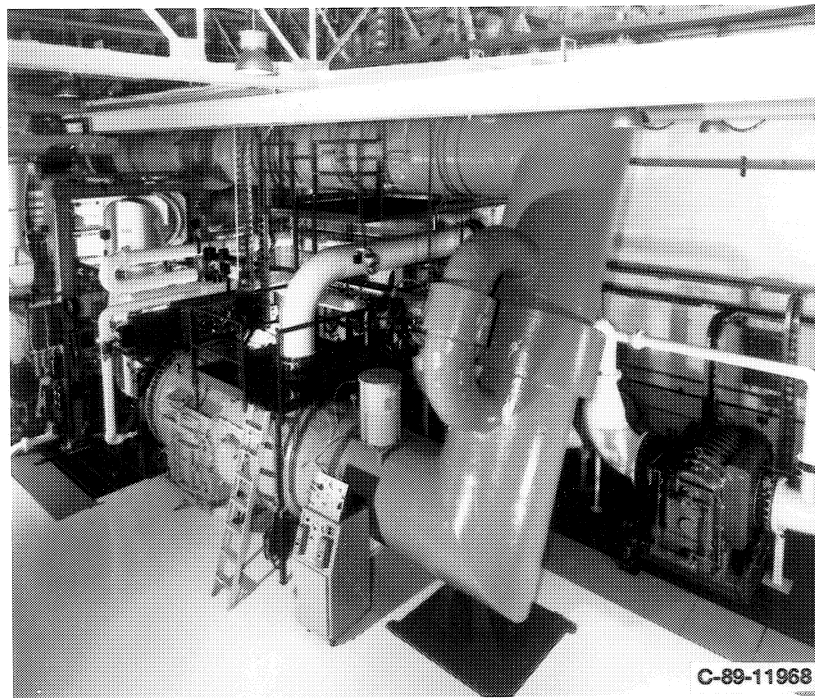
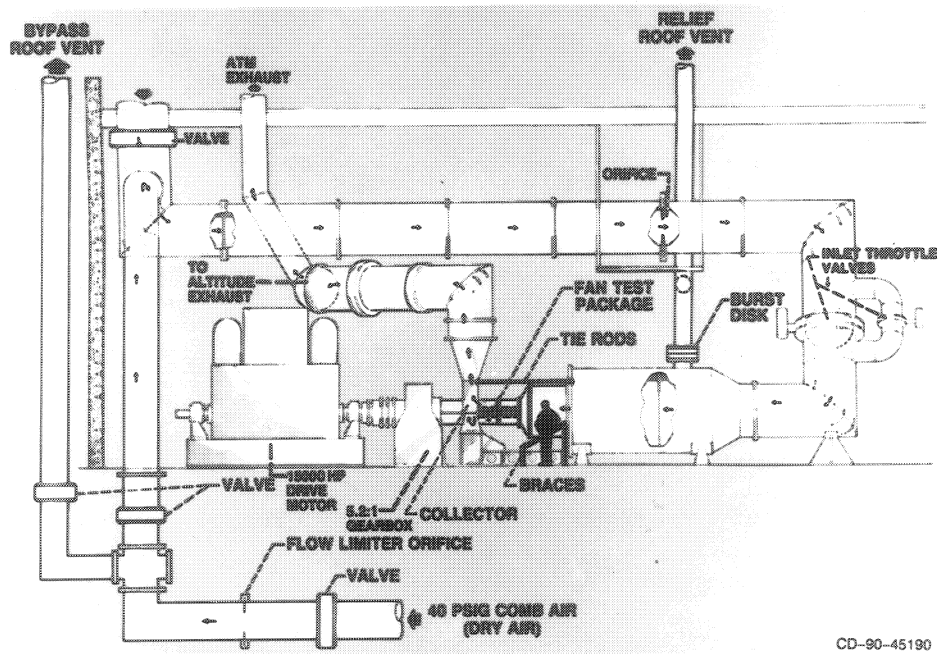
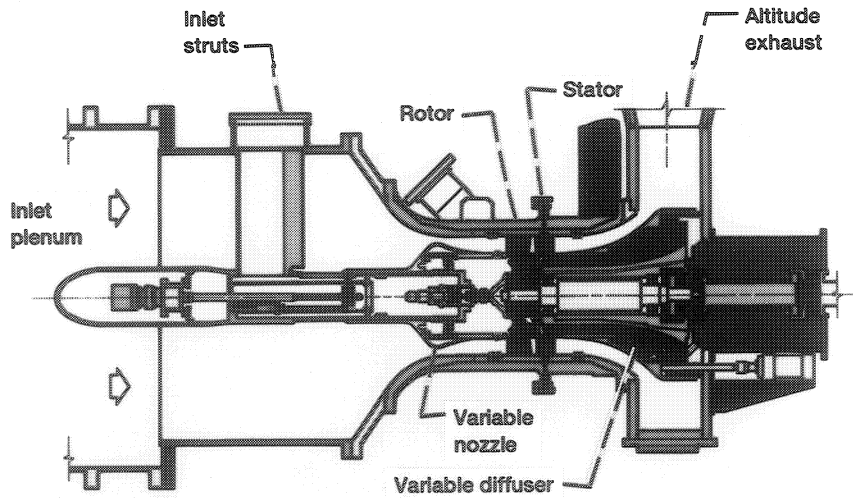
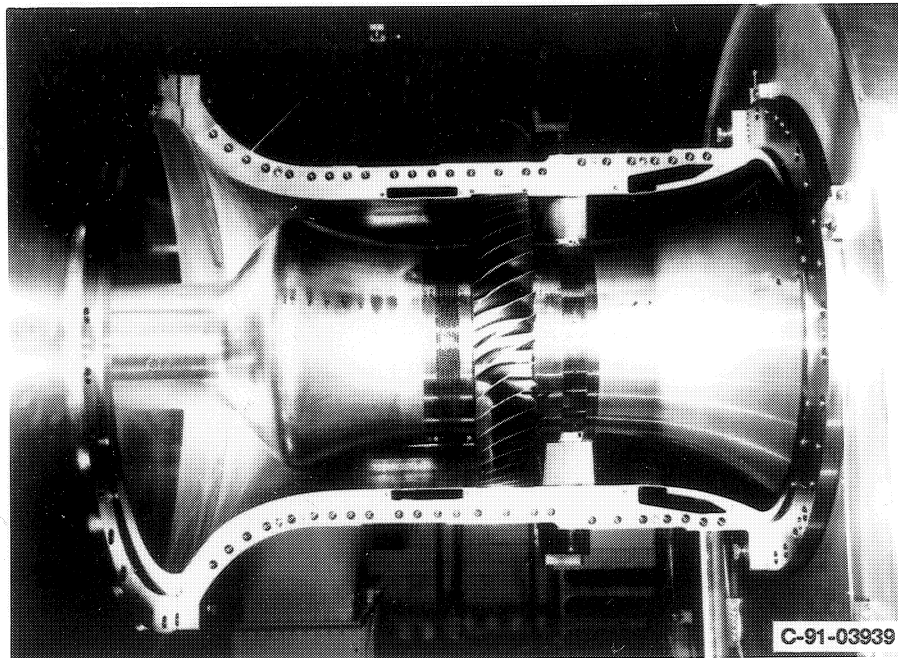

Figure 3.—Supersonic throughflow fan test facility.



C-89-12110



C-91-03939

Figure 4.—Supersonic throughflow fan test package.

Transducer	Position ^a z	
	cm	in.
A	-203.2	-80.0
B	-20.3	-8.0
C	10.7	4.2
D	30.0	11.8
E	82.6	32.5

^aPosition from rotor leading edge at hub

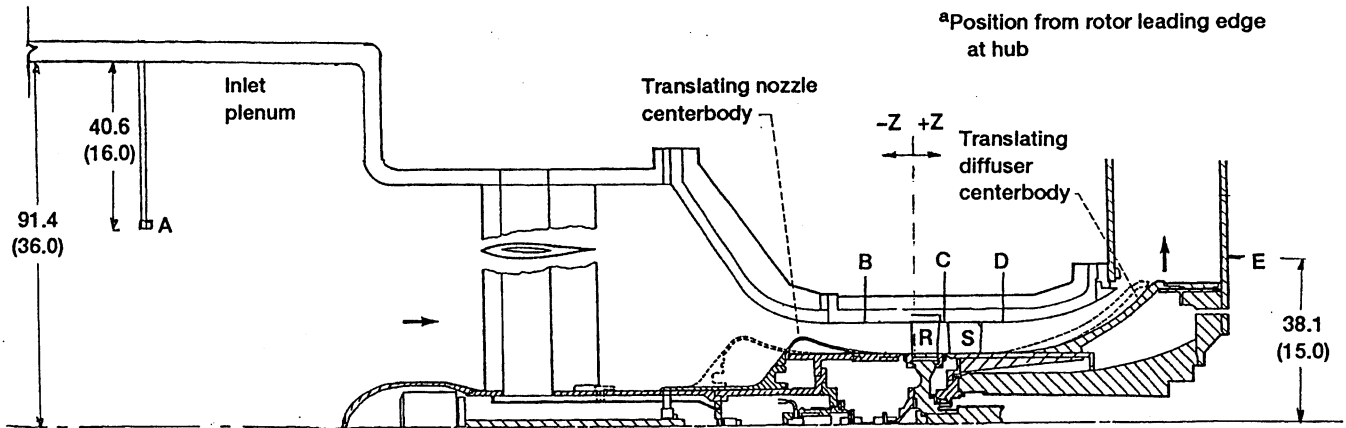

Figure 5.—Transducer positions. All dimensions in centimeters (inches).

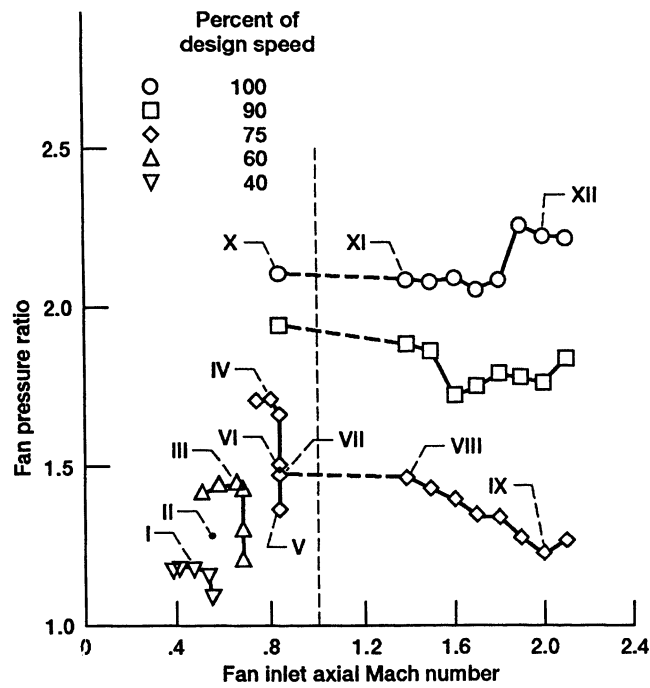

Figure 6.—Test conditions.

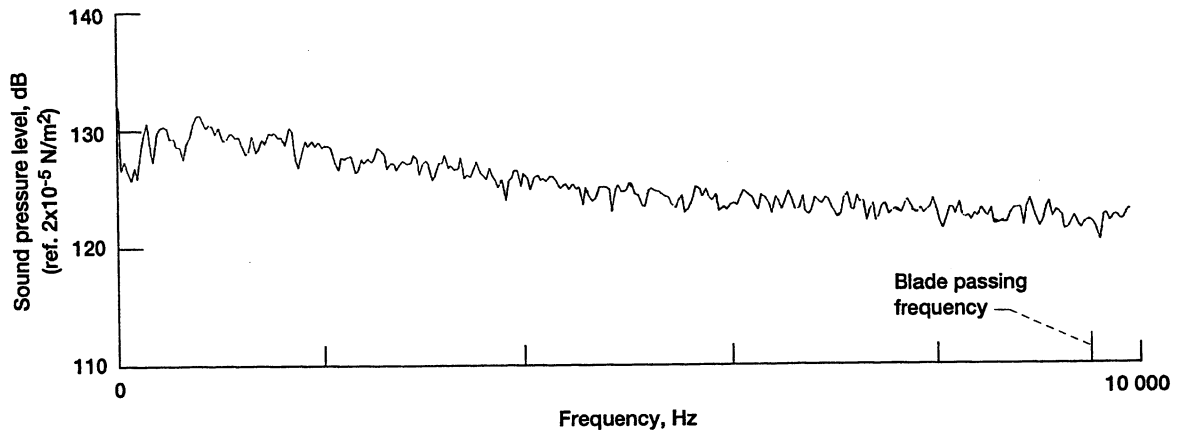

Figure 7.—Spectra for transducer A at condition IV (0 to 10 000 Hz).

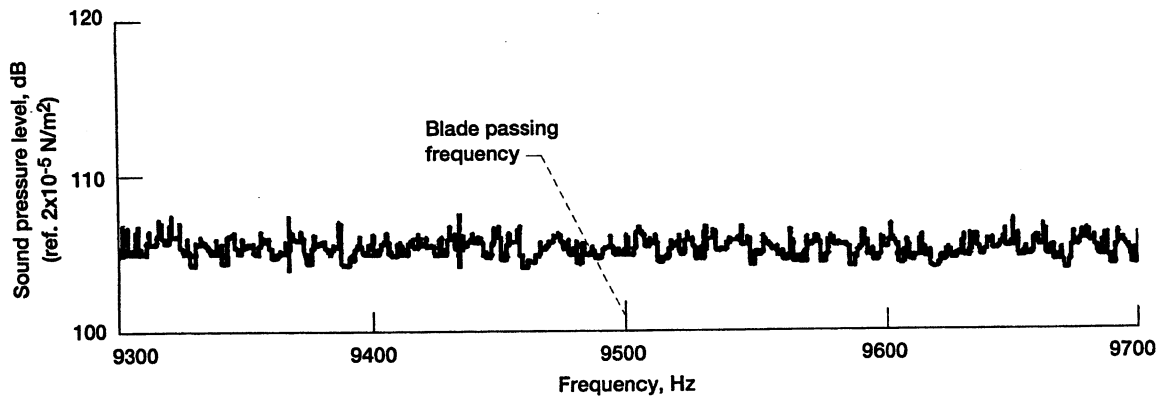

Figure 8.—Zoom spectra for transducer A at condition IV.

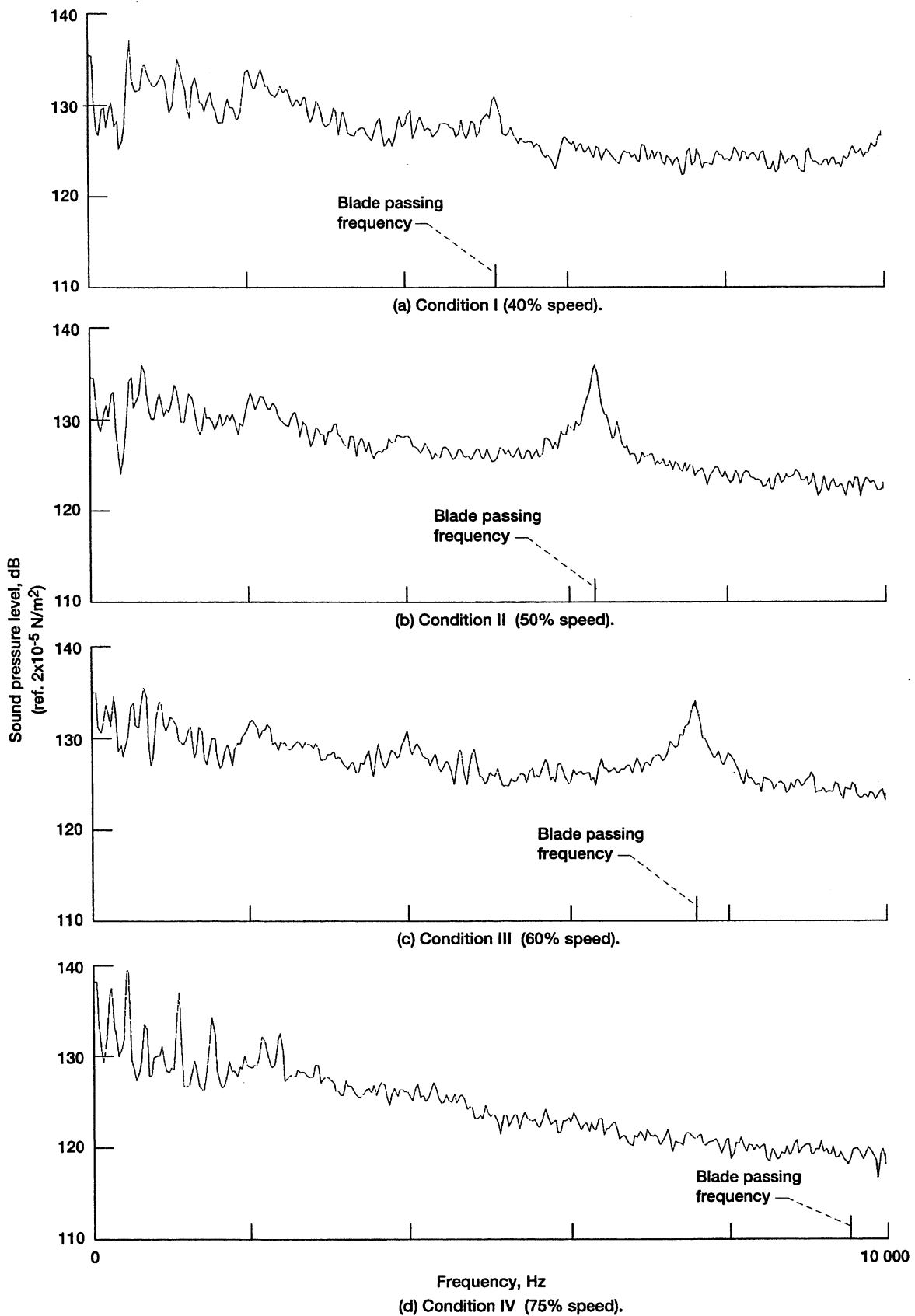

Figure 9.—Spectra for transducer B.

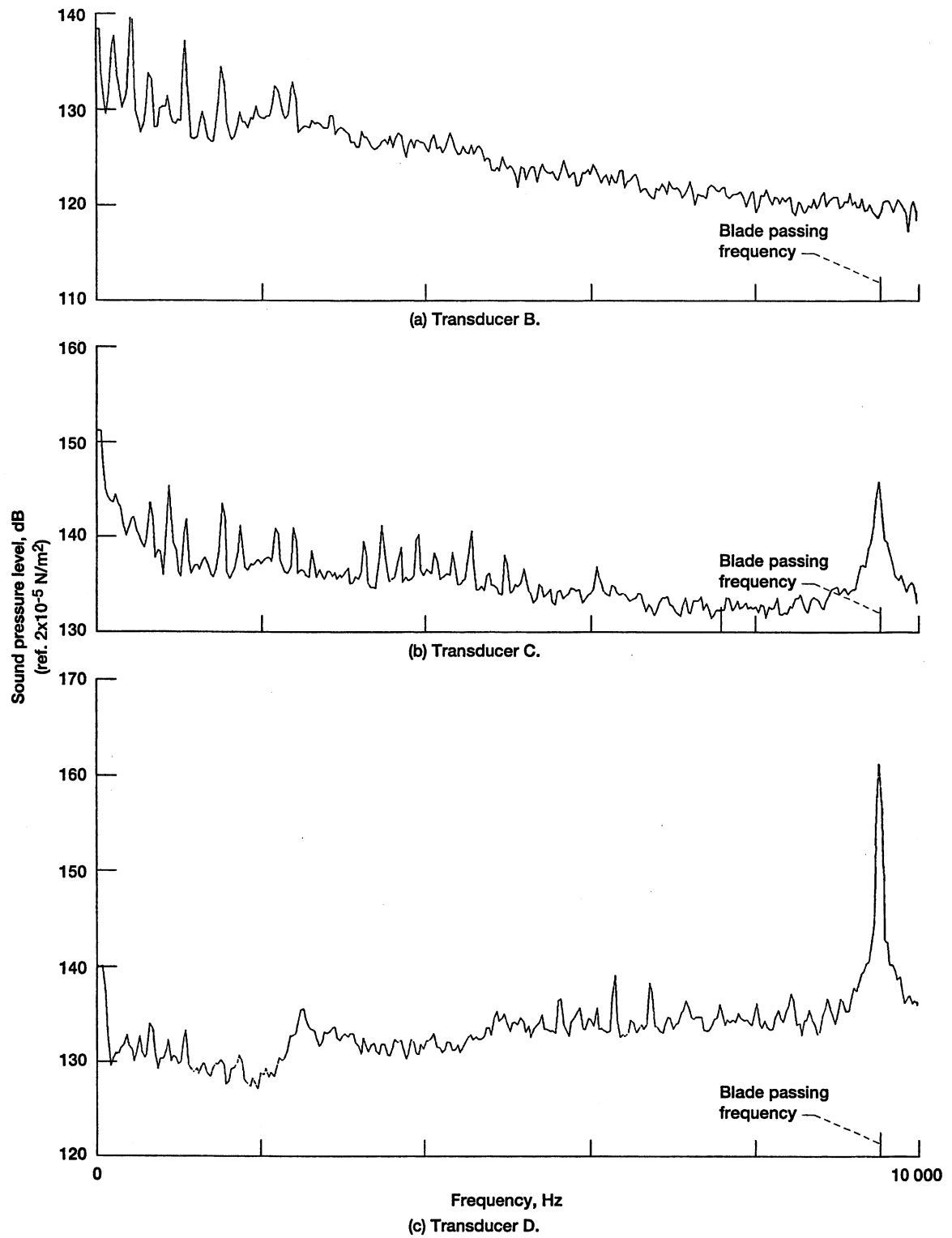

Figure 10.—Spectra at condition IV.

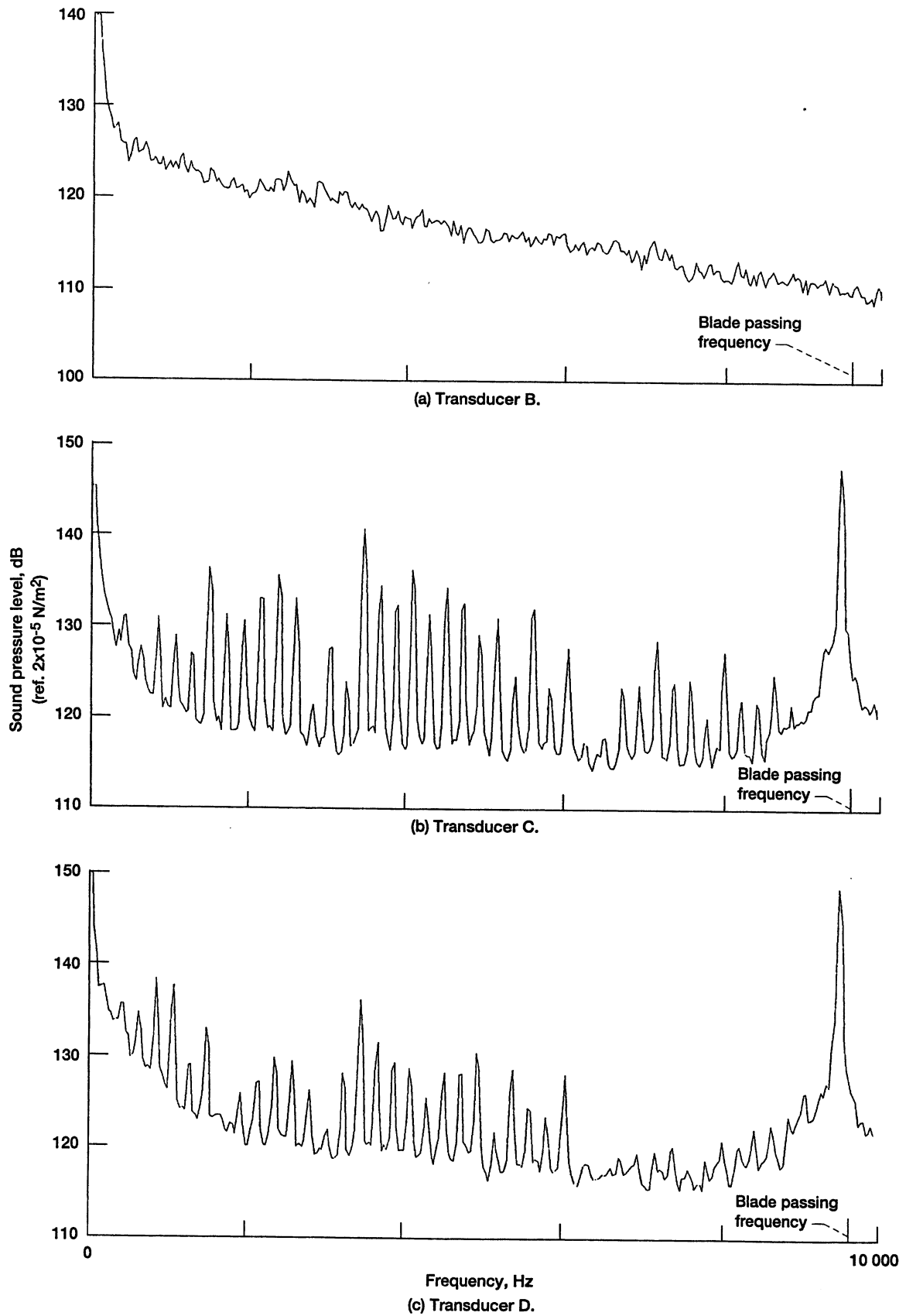

Figure 11.—Spectra at condition VIII.

REPORT DOCUMENTATION PAGE

Form Approved
OMB No. 0704-0188

Public reporting burden for this collection of information is estimated to average 1 hour per response, including the time for reviewing instructions, searching existing data sources, gathering and maintaining the data needed, and completing and reviewing the collection of information. Send comments regarding this burden estimate or any other aspect of this collection of information, including suggestions for reducing this burden, to Washington Headquarters Services, Directorate for Information Operations and Reports, 1215 Jefferson Davis Highway, Suite 1204, Arlington, VA 22202-4302, and to the Office of Management and Budget, Paperwork Reduction Project (0704-0188), Washington, DC 20503.

1. AGENCY USE ONLY (<i>Leave blank</i>)		2. REPORT DATE April 1993	3. REPORT TYPE AND DATES COVERED Technical Memorandum	
4. TITLE AND SUBTITLE Noise Trends of a 0.5-m- (20-in.-) Diameter Supersonic Throughflow Fan as Measured in an Unmodified Compressor Aerodynamic Test Facility			5. FUNDING NUMBERS WU-535-03-10	
6. AUTHOR(S) James H. Dittmar, David G. Hall, and Royce D. Moore				
7. PERFORMING ORGANIZATION NAME(S) AND ADDRESS(ES) National Aeronautics and Space Administration Lewis Research Center Cleveland, Ohio 44135-3191			8. PERFORMING ORGANIZATION REPORT NUMBER E-7618	
9. SPONSORING/MONITORING AGENCY NAME(S) AND ADDRESS(ES) National Aeronautics and Space Administration Washington, DC 20546-0001			10. SPONSORING/MONITORING AGENCY REPORT NUMBER NASA TM-106041	
11. SUPPLEMENTARY NOTES James H. Dittmar and Royce D. Moore, NASA Lewis Research Center and David G. Hall, Sverdrup Technology, Inc., Lewis Research Center Group, 2001 Aerospace Parkway, Brook Park, Ohio 44142. Responsible person, David M. Elliott, organization code RTA, 216-433-8711.				
12a. DISTRIBUTION/AVAILABILITY STATEMENT Restriction changed to Unclassified/Unlimited per DAA modified May 19, 2006, by authority of the NASA Glenn Research Center, Programs and Projects Directorate Office. LIMITED DISTRIBUTION DOCUMENT Because of its significant technological potential, this information, which has been developed under a U.S. Government program, is being given a limited distribution whereby advance access is provided for use by domestic interests. This legend shall be marked on any reproduction of this information in whole or in part. Date for general release _____ April 1998 _____ Available electronically at http://gltrs.grc.nasa.gov This publication is available from the NASA Center for Aerospace Information, 301-621-0390. Subject Category 71			12b. DISTRIBUTION CODE	
13. ABSTRACT (<i>Maximum 200 words</i>) The tone noise levels of a supersonic through flow fan were measured at subsonic and supersonic axial duct Mach numbers. The noise in the inlet plenum showed no blade passing and harmonic tones at subsonic or supersonic axial flow conditions. At subsonic axial flow conditions, the supersonic throughflow fan showed no inlet plenum tones at operating conditions where tone noise had been previously measured for a subsonic fan design. This lower inlet-quadrant noise level for the supersonic throughflow fan was the result of an high subsonic inlet velocities acting to reduce the noise propagating out the inlet. The fan noise, which was prevented from propagating upstream by the high subsonic inlet velocities, appeared to increase the noise in the exhaust duct at subsonic throughflow conditions. The exhaust duct noise decreased at supersonic axial throughflow Mach numbers, with the lowest blade passing and harmonic tones levels being observed at the design axial Mach number of 2.0. Multiple pure tone noise was observed in the inlet duct at subsonic axial flow Mach numbers but was seen only in the exhaust duct at supersonic axial flow conditions.				
14. SUBJECT TERMS Noise; Fans; Supersonic			15. NUMBER OF PAGES 25	
			16. PRICE CODE	
17. SECURITY CLASSIFICATION OF REPORT Unclassified	18. SECURITY CLASSIFICATION OF THIS PAGE Unclassified	19. SECURITY CLASSIFICATION OF ABSTRACT Unclassified	20. LIMITATION OF ABSTRACT	