

N 62 52233

NATIONAL ADVISORY COMMITTEE  
FOR AERONAUTICS

TECHNICAL NOTES

APR 18 1926

NATIONAL ADVISORY COMMITTEE FOR AERONAUTICS

CASE FILE  
COPY

\_\_\_\_\_  
No. 233  
\_\_\_\_\_

N.A.C.A. FLIGHT-PATH-ANGLE AND AIR-SPEED RECORDER

By Donald G. Coleman  
Langley Memorial Aeronautical Laboratory

\_\_\_\_\_  
Washington  
April, 1926



NATIONAL ADVISORY COMMITTEE FOR AERONAUTICS.

---

TECHNICAL NOTE NO. 233.

---

N.A.C.A. FLIGHT-PATH-ANGLE AND AIR-SPEED RECORDER.

By Donald G. Coleman.

Summary

A new trailing bomb-type instrument for photographically recording the flight-path angle and air speed of aircraft in unaccelerated flight is described. The instrument consists essentially of an inclinometer, air-speed meter, constant-speed motor and a film-drum case. The inclinometer carries an oil-damped pendulum which records optically the flight-path angle upon a rotating motor-driven film drum. The air-speed meter consists of a taut metal diaphragm of high natural frequency which is acted upon by the pressure difference of a Prandtl type Pitot-static tube. The inclinometer record and air-speed record are made optically on the same sensitive film. Two records taken by this instrument are shown.

Introduction

This instrument was designed and built by members of the staff of the National Advisory Committee for Aeronautics at its research laboratory, Langley Field, Virginia, in order to have an accurate means available for recording the flight-path



angle and air speed of an airplane. The flight-path angle and air speed being desired for the determination of the lift and drag characteristics of an airplane in flight (Reference 1).

This trailing flight test instrument is of the photographic type, giving a simultaneous single record of the flight-path angle and air speed of an airplane in unaccelerated flight. The main body of the instrument is of streamline form which permits the instrument, when suspended from an airplane in flight, to assume a position as nearly under the center of gravity of the airplane as possible.

The instrument has an over-all length of 41 3/4 in., and has a maximum diameter of 5.4 in. The total weight of the instrument is 18 1/4 lb. Projecting from the streamline body is a monel metal Prandtl type Pitot-static tube. The distance (17 in.) from the static openings on the Pitot tube to the maximum diameter of the instrument permits the readings of the pressure head to be practically free from interference (Reference 2). The operating mechanism, shown in Figs. 1 and 2, is housed in an aluminum casting the interior of which contains a small constant-speed motor, a film drum, three light sources, an inclinometer and an air-speed capsule. The tail is made of four aluminum stabilizing fins which maintain the axis of the instrument parallel to the direction of the flight-path angle.



## Inclinometer

The inclinometer unit (Fig. 3), which records the flight-path angle, consists of an oil-damped pendulum carrying a mirror system which reflects a light beam to the photographic film. The pendulum bob is made of a steel block, the top of which is drilled to take the aluminum alloy pendulum arm which is securely riveted into position. On the front and back surfaces as well as on each end of the pendulum bob are machine-cut grooves which serve as damping vanes. These vanes are supplemented by two thin aluminum plates placed parallel to the pendulum bob and riveted to the pendulum arm. Cemented to the hub of the pendulum are three  $3/16$  in. by  $1/8$  in. plane silvered mirrors placed parallel to the axis of the pendulum movement, the outer mirrors forming obtuse angles with the center mirror. Three mirrors are used to permit a greater film range per degree mirror deflection. The pendulum is suspended upon hardened steel pivots which engage in highly polished sockets on the inclinometer case. The entire pendulum and mirror system is enclosed in an oil-tight aluminum alloy case. The case has a  $1/8$  in. diameter window consisting of a lens and holder of similar construction to that in the air-speed capsule described later in this paper. The window permits a light beam, reflected by the mirrors, to reach the film. The inclinometer case is completely filled with a transparent damping fluid. An



aluminum alloy reservoir containing the damping fluid is connected to the inclinometer case. This reservoir insures the inclinometer case being completely filled and allows for the temperature expansion changes of the damping fluid. The selection of the damping fluid depends upon sensitivity and the temperature at which the instrument is to be used; a mixture of 80 per cent Nujol and 20 per cent gasoline was found to be quite satisfactory for actual flight tests made between the temperatures of  $+40^{\circ}\text{C}$  and  $-18^{\circ}\text{C}$ . Experiments on viscosity-temperature change, however, are now being conducted to obtain a damping medium/<sup>suitable</sup> for a greater temperature range.

#### Air-Speed Meter

The air-speed meter used in the flight-path-angle recorder is of the most recent National Advisory Committee for Aeronautics design. As this capsule-type instrument, shown diagrammatically in Fig. 4, is of general usefulness in recording pressure difference a complete description is given. It consists essentially of a flat circular metal diaphragm (A) supported near the periphery and enclosed within a metal case (B). One side of this diaphragm rests on a ledge forming an airtight joint. On the other side there is a paper gasket and a thin steel washer (C). This washer has on its circumference a small nib which engages a drill hole on the case. The back of the



capsule consists of a large diameter screw plug, threaded into a ring (D). The ring bears against the washer, thus rigidly clamping the metal diaphragm. A small stylus (E) is attached to the center of the diaphragm and the point presses against the back of a small mirror (F) which is free to rotate. The point of contact of the stylus is offset from the axis of rotation of the mirror, thus a forward movement of the stylus imparts a rotational motion to the mirror. Contact between the mirror and the stylus point is maintained by a delicate hair-spring (G) fastened to the mirror and case. Near the movable mirror there is a smaller mirror (H) rigidly secured to the case. The face of the case contains a convex lens (I) which, together with the mirrors form an optical system of short focal length. Two short tubes at the back of the case lead respectively to the airtight chambers on either side of the diaphragm. The exterior ends of the tubes are connected to a Pitot-static head. Any difference of pressure between the two airtight chambers causes movement of the free mirror, and this movement is recorded photographically on a rotating film; a light beam being directed on to the mirrors, the stationary one providing a reference line from which to measure the deflection of the recording beam. The sensitivity of the air-speed capsule may be changed by means of adjusting screws (J) which move the entire mirror system with respect to the stylus point.

Fig. 5 shows the capsule parts while Fig. 6 shows the as-



sembled capsule.

The thickness of the diaphragm used may vary with the pressure to be recorded. Steel diaphragms ranging in thickness from .00125 in. to .10000 in. have been used with success in this type of capsule. The air-speed capsule of the flight-path-angle and air-speed recorder is equipped with a diaphragm of .002 in. gauge whose sensitivity can be adjusted over a pressure range of from 2 in. to 14 in. of water head pressure for  $2 \frac{7}{16}$  in. full-scale deflection. The natural frequency of this diaphragm and mirror is about 270 vibrations per second.

#### Optical System

Both the inclinometer and the air-speed capsule have separate light sources which are so arranged as to permit the light from each lamp to pass through the lens to the mirror of their respective units from which it is reflected back through the same lens to the film. In addition to the above light sources there is a timing lamp. The timing lamp is protected by a slitted metal shield which allows its intermittent light beam to strike directly across the film and thus record a time scale. Each lamp consists of a 3.8 volt bulb designed to give a straight line source.



### Film Drum

A removable section in the instrument case allows easy access to the film drum (Fig. 9). The film drum is housed in a light-tight film case which contains a slit (Fig. 7). The drum revolves once in six minutes by means of a geared shaft which is driven by a small N.A.C.A. constant-speed motor (Reference 3). The film, when stretched smoothly and tightly about the drum with sensitive side outward, is secured by means of a clip. The film and drum are placed in the film case and automatically locked into position by a spring catch. An automatic shutter is attached to the slit on the film case and is normally closed by a spring. When the film case is put in position in the instrument the shutter is automatically opened, thus allowing a quick interchange of drums without danger of fogging. The film drum being in place the removable section in the instrument case is locked into position by a nut which streamlines the nose.

### Calibration

The air-speed meter unit of the instrument is calibrated in the laboratory by balancing the pressure on the capsule diaphragm against a water or alcohol column of a manometer by means of a tube connection temporarily placed between the Pitot tube of the instrument and the manometer. The diaphragm de-



flection produced by a known manometer pressure is photographically recorded on the film as a short line. From the scaled values of several such lines each representing a different pressure but recorded on the same film, a calibration curve is plotted, as shown in Fig. 8.

A laboratory calibration of the inclinometer unit is obtained by leveling the fully assembled instrument upon a calibration stand as shown in Fig. 9. This stand permits the instrument to be rotated about a central axis through a range of  $\pm 16^\circ$ , the change of angle with respect to the horizontal is then read from a graduated scale. A photographic record is made at  $2^\circ$  intervals.

Each new instrument is suspended in a wind tunnel to determine whether the true aerodynamic axis of the instrument corresponds to the geometric axis. When there is any deviation from the geometric axis a correction to the calibration is applied as shown in Fig. 10. During the wind tunnel tests the air-speed meter of the instrument is checked against a Pitot tube in the tunnel.

#### Operation

A record of the horizontal position of the instrument while on the calibration stand is taken just prior to the flight and is repeated at the end of the flight merely as a check upon the operation of the instrument during the flight. When the air-



plane is taking off or landing the instrument is held in a cradle beneath the fuselage as shown in Fig. 11. During flight, when it is desired to operate the instrument it is lowered by means of a  $3/16$  in. outside diameter armored cable passing over a windlass which is operated from within the fuselage. The cable is secured to the instrument by a steel T-shaped arm on which two angular ball bearings are mounted so that the instrument may pivot about its center of mass through a range of  $\pm 20^\circ$ . The center of the cable contains two insulated copper wires connected to the instrument through the T-shaped arm. The wires as well as the armored cable serve as battery leads thus allowing the instrument to be operated from the fuselage by merely closing a switch connected to an 8-volt storage battery. The cable used is about 30 ft. in length, which permits the instrument when suspended from the airplane to reach the least disturbed air of any trailing type of flight test instrument heretofore used at this laboratory. The forces acting upon the suspended instrument impart an oscillation of six-second period to the instrument.

Two records obtained in free flight are shown in Figs. 12 and 13.

#### Precision

The air-speed capsule pressure readings as recorded upon  $2\ 7/16$  in. wide film used in this instrument are accurate to



within 1 per cent of full-scale deflection.

In spite of the oscillation of the entire instrument when suspended from the airplane the accuracy of the inclinometer readings can be scaled to within  $\pm 1/10$  of a degree by taking the mean of the extreme points on the record.

#### Uses for the Instrument

In many flight tests it is necessary to know the flight-path-angle and the air speed in order to analyze the forces acting on the airplane. The instrument herein described records directly the flight-path angle from which the lift and drag characteristics of the airplane may be determined. A knowledge of the lift and drag characteristics is of great importance to the designer of the full-size airplane and is also used for the comparison of the data obtained from tests on airplane models in wind tunnels with the data obtained in flight tests.

The instrument may also be used to provide a check on the level flight path of an airplane which is of great value in many flight tests.

The lift and drag characteristics as obtained by the flight-path-angle and air-speed recorder can also be used for the determination of propeller characteristics on the full-scale propellers while in flight (Reference 4).

The instrument has been successfully used on numerous tests



and has furnished very accurate information with the least effort on the part of the observer of any flight-path-angle and air-speed recorder available at the present time. The instrument is further recommended for ease of installation and reproducibility of records.

#### References

1. Green, Maurice W.: Determination of the Lift and Drag Characteristics of an Airplane in Flight. N.A.C.A. Technical Note No. 223. 1925.
2. Reid, E. G.: Interference Tests on an N.A.C.A. Pitot Tube. N.A.C.A. Technical Report No. 199. 1925.
3. Norton, F. H.: N.A.C.A. Recording Air-Speed Meter. N.A.C.A. Technical Note No. 64. 1921.
4. Durand, W. F.  
and : Comparison of Tests on Airplane Propellers in Flight with Wind Tunnel Model  
Lesley, E. P. Tests on Similar Forms. N.A.C.A. Technical Report No. 220. 1926.



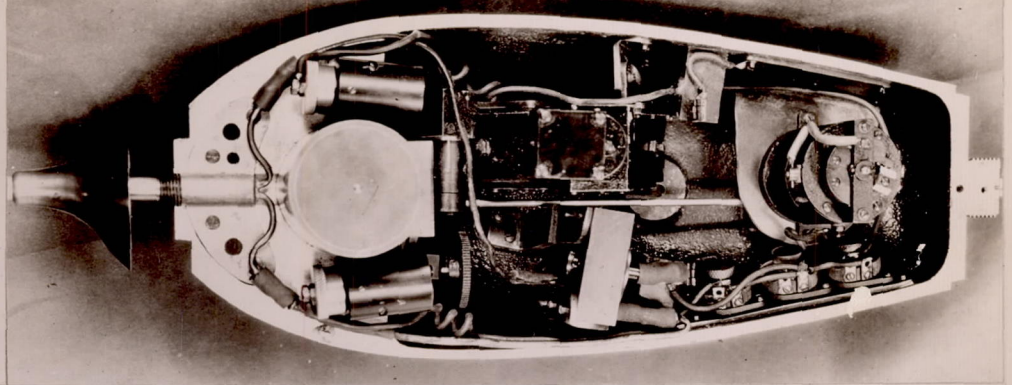

Fig.1 Operating mechanism of the flight-path-angle and air-speed recorder.

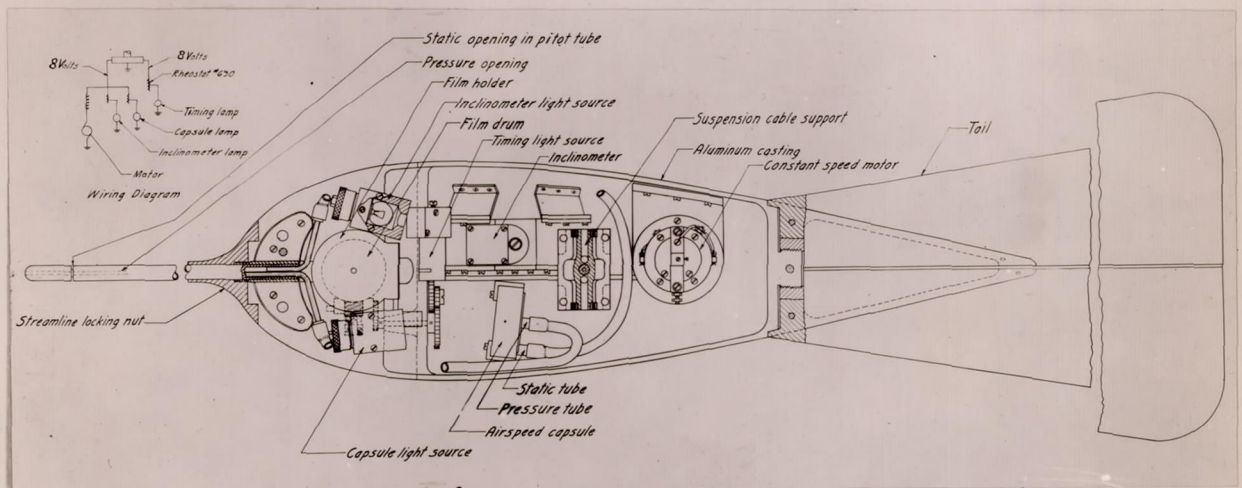

Fig.2 Flight-path-angle and air-speed recorder.

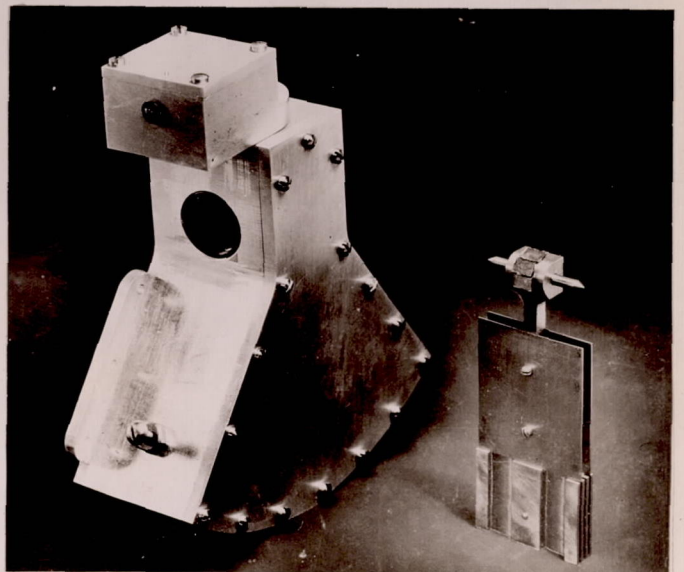

Fig.3 Inclinometer unit with pendulum detached.

2480 A.S.



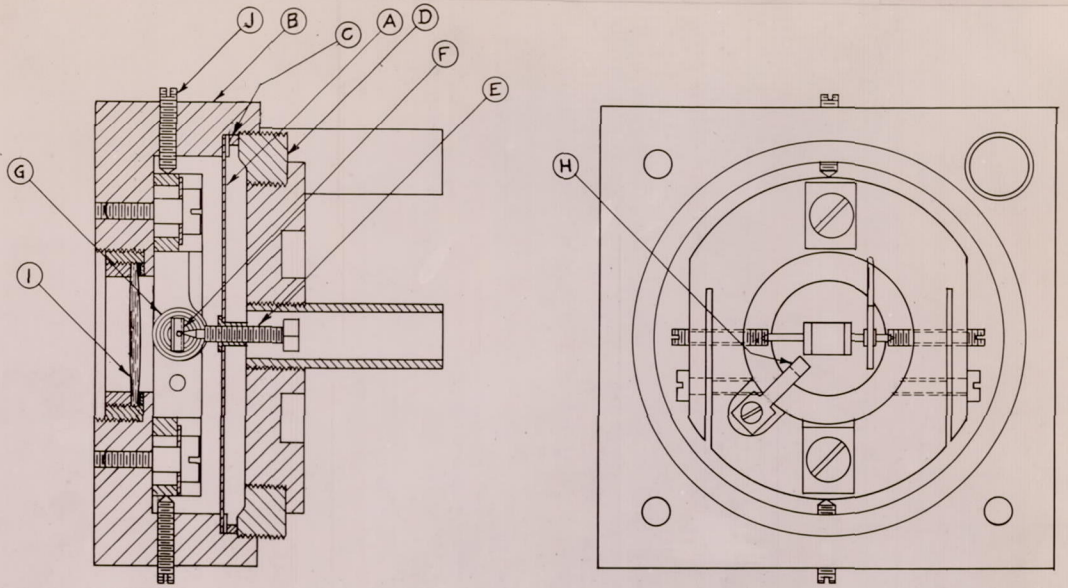

Fig.4 N.A.C.A. Capsule.

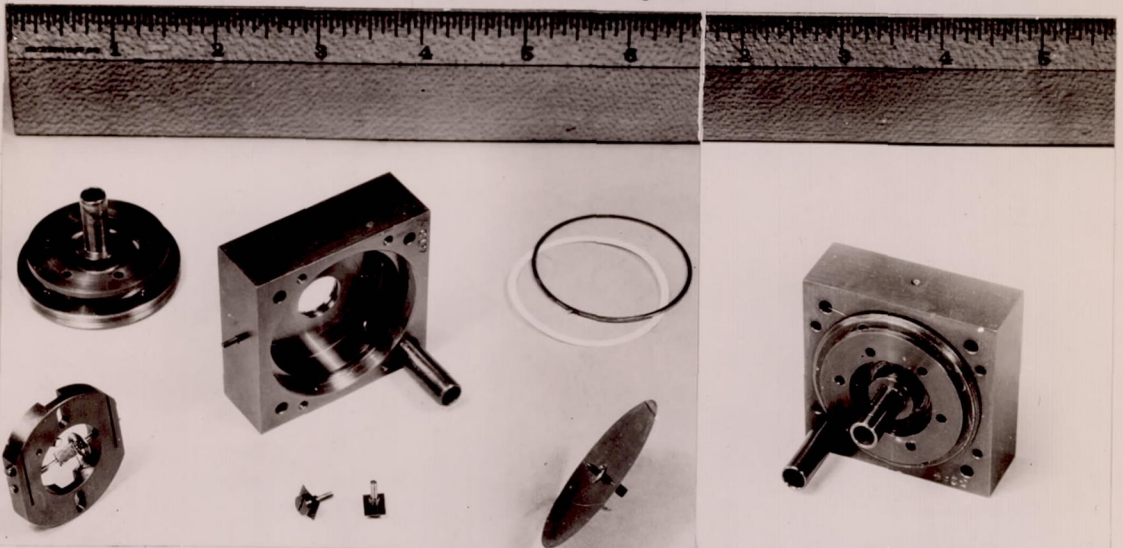

Fig.5 Capsule parts.

Fig.6 Assembled N.A.C.A. capsule.

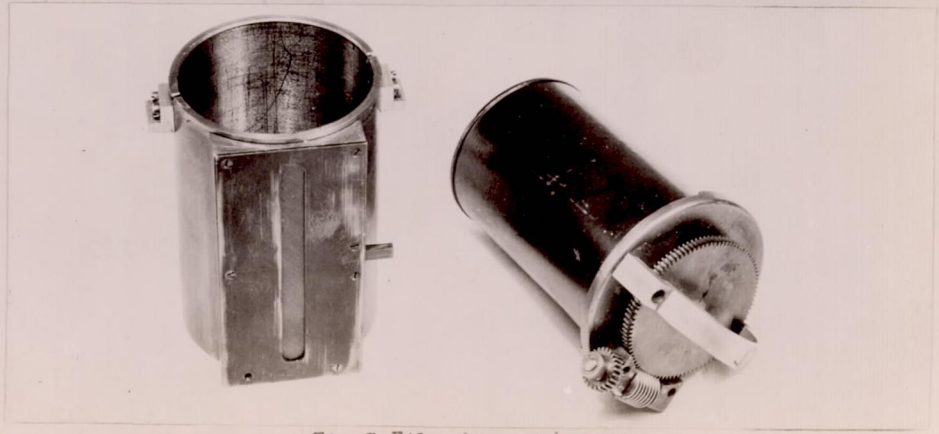

Fig.7 Film drum and case.



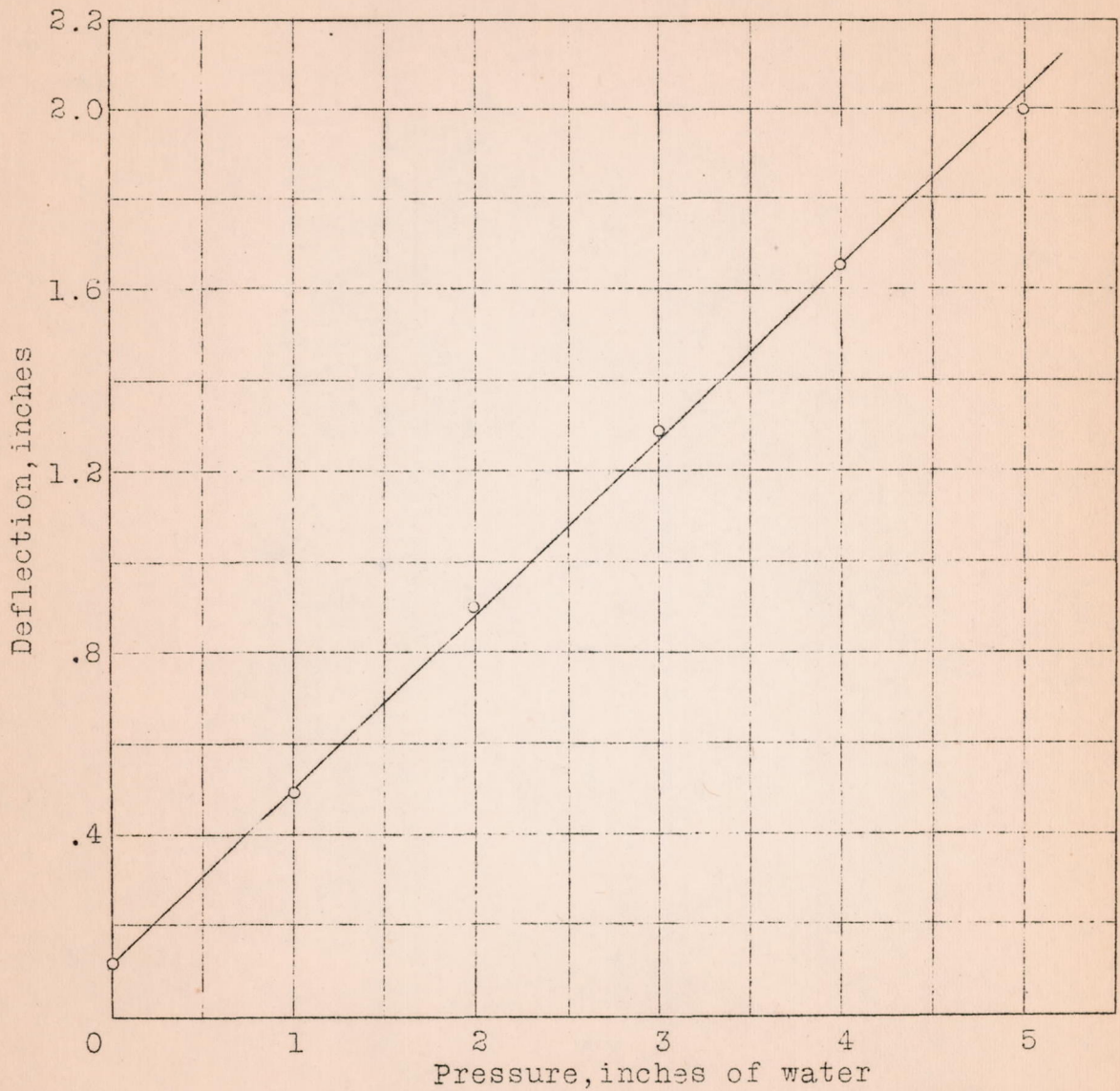

Fig.8 Calibration of air-speed capsule No.G7. Flight-path-angle and air-speed recorder, instrument No.148.



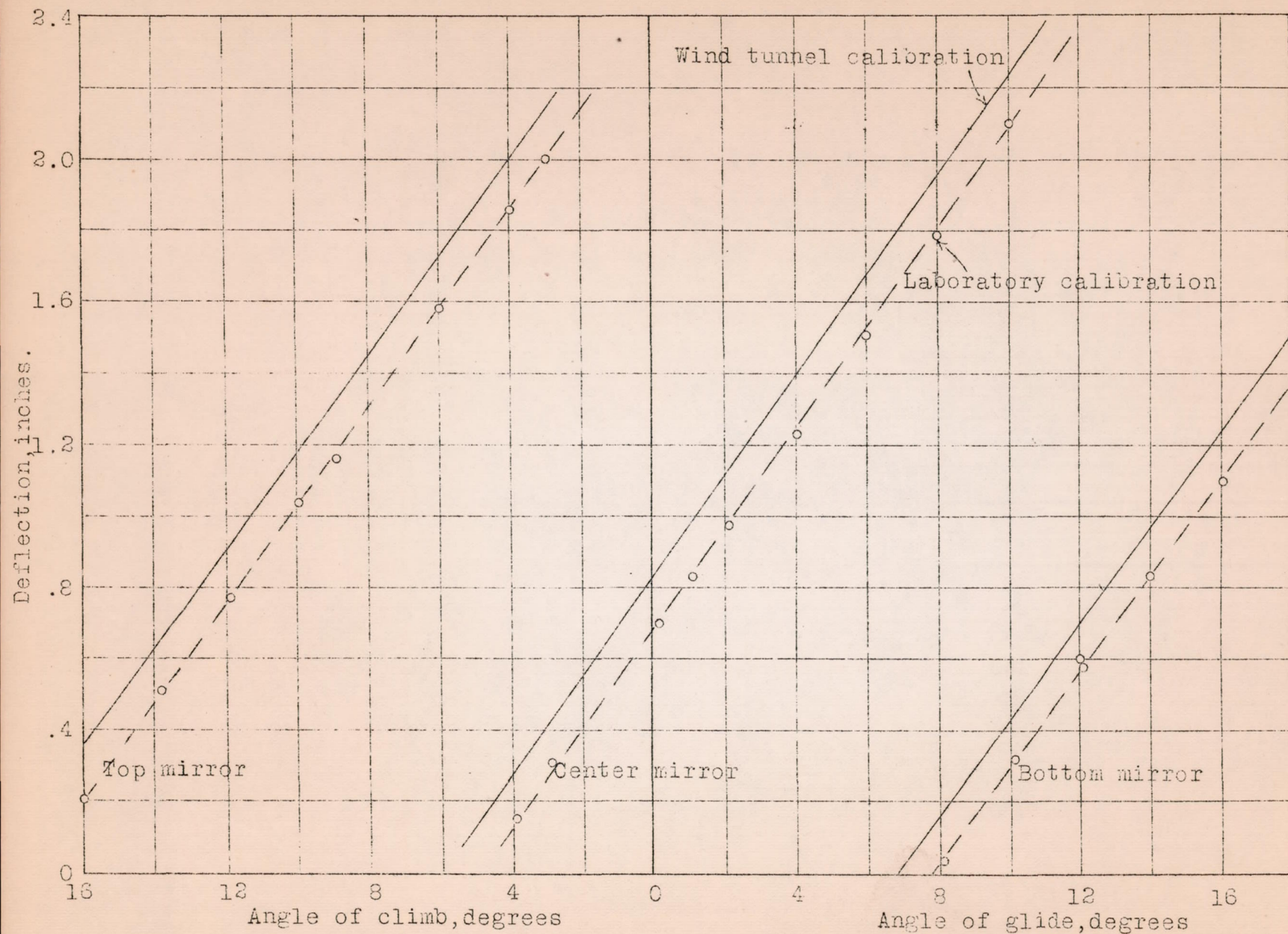

Fig. 10 Calibration of inclinometer. Flight-path-angle and air-speed recorder, instrument No. 148.



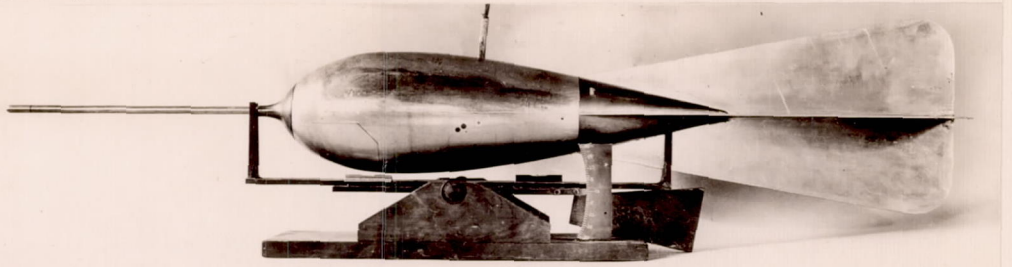

Fig.9 Flight-path-angle and air-speed recorder mounted on calibration stand, showing locking nut and detachable section for film loading.



Fig.11 Flight-path-angle and air-speed recorder mounted in cradle, ready for taking off and landing.

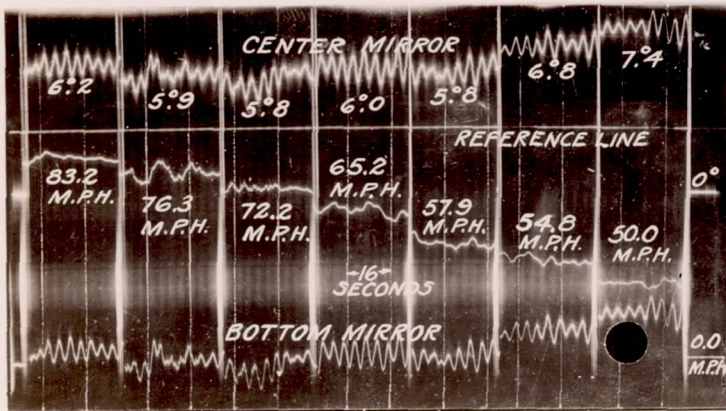

Fig.12 VE-9 airplane. Recorder No.145

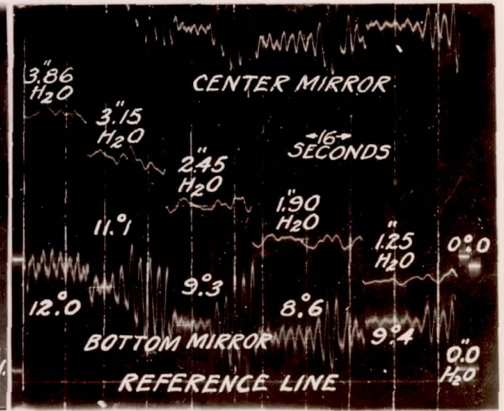

Fig.13 Sperry Messenger airplane. Recorder No.148

Free flight records obtained by flight-path-angle and air-speed records.