

ADDITIONAL COPY
NO. 6

TECHNICAL NOTES

NATIONAL ADVISORY COMMITTEE FOR AERONAUTICS

No. 268

THIS DOCUMENT ON LOAN FROM THE FILES OF

NATIONAL ADVISORY COMMITTEE FOR AERONAUTICS
LANGLEY MEMORIAL AERONAUTICAL LABORATORY
LANGLEY FIELD, HAMPTON, VIRGINIA

RETURN TO THE ABOVE OFFICE

REQUESTS FOR REPRODUCTION OF THIS DOCUMENT
AS FOLLOWS.

NATIONAL ADVISORY COMMITTEE FOR AERONAUTICS
1224 P STREET, N.W.
WASHINGTON, D. C.

MASS DISTRIBUTION AND PERFORMANCE OF FREE FLIGHT MODELS

By Max Scherberg and R. V. Rhode
Langley Memorial Aeronautical Laboratory

Washington
October, 1927

NATIONAL ADVISORY COMMITTEE FOR AERONAUTICS.

TECHNICAL NOTE NO. 268.

MASS DISTRIBUTION AND PERFORMANCE OF FREE FLIGHT MODELS.

By Max Scherberg and R. V. Rhode.

Summary

This note deals with the mass distribution and performance of free flight models. An airplane model which is to be used in free flight tests must be balanced dynamically as well as statically, e.g., it must not only have a given weight and the proper center of gravity but also a given ellipsoid of inertia. Equations which relate the motions of an airplane and its model are given. Neglecting scale effect, these equations may be used to predict the performance of an airplane, under the action of gravity alone, from data obtained in making dropping tests of a correctly balanced model.

It is shown how a light model, built with little regard to its mass distribution, may be loaded with masses of predetermined weight, shape, position and attitude to give the distribution desired.

It is indicated how this method of distributing the mass in a body to obtain a desired distribution, together with the model dropping tests may be used to determine the most desirable inertia characteristics of an airplane of given shape.

Introduction

Model dropping tests were recently instituted at the Langley Memorial Aeronautical Laboratory as a means of studying the spinning characteristics of airplanes. The model was dropped in the spinning attitude from approximately 100 feet height and motion pictures were taken of its descent (results soon to be published).

In free flying models, the mass forces and their moments greatly affect the performance, and therefore the quantity and distribution of mass cannot be overlooked in the construction of the model. Since any motion may be considered as made up of a series of steady helical motions which take place during infinitesimal time increments, the kinetics of the problem will be dealt with in two parts. First, the mass distribution required for the simulation of a steady helical motion of the airplane will be developed. Second, it will then be shown that the distribution found for this case is satisfactory for the simulation of any motion whether steady or not and whatever the path.

The equations relating to the motions of the airplane and its model are given and it is shown how a model may be statically and dynamically balanced by means of two simple blocks of loading material.

PART I.

Mass Distribution for a Steady Helical Motion

It will be considered that this type of motion is obtained in the normal tail spin. Hence this treatment will indicate the distribution desired for the imitation of a normal tail spin.

It is desired to so adjust the quantity and distribution of the mass of a model having linear dimensions N times those of the full-scale airplane that the model will be in kinetic equilibrium in a steady helical motion which is geometrically similar to that described by the airplane.

In order that the motions shall be similar the helix angles of homologous point paths must be equal.

Hence

$$\frac{\omega l}{V} = \frac{\omega_m l_m}{V_m} \quad \text{or} \quad \frac{\omega}{\omega_m} = \left(\frac{V}{V_m} \right) N \quad (1)$$

in which V is the vertical velocity, ω the angular velocity about the spin axis and l a representative linear dimension; the subscript m refers to the model. The directions of the vectors representing the gravitational, centripetal and aerodynamic forces are identical in both cases because the motions are similar. Their resultants must be zero as the motions are steady. The vector diagrams of the forces are therefore similar triangles. As the aerodynamic forces are proportional to $l^2 V^2$ (scale effect neglected), the gravitational forces proportional to the

mass (M), and the centripetal forces to $M \omega^2 l$,

$$\frac{M}{M_m} = \frac{l^2 V^2}{l_m^2 V_m^2} \quad (2)$$

and

$$\frac{M \omega^2 l}{M_m \omega_m^2 l_m} = \frac{l^2 V^2}{l_m^2 V_m^2} \quad (3)$$

From the equations (1), (2), and (3):

$$\omega = \omega_m \sqrt{N} \quad (4)$$

$$V = V_m / \sqrt{N} \quad (5)$$

and

$$M = M_m / N^3 \quad (6)$$

The relationships which must exist between the angular and linear velocities and the masses have now been established.

The relations, however, suffice only to insure zero resultant forces; the conditions which must exist in order that the resultant moments corresponding to these forces shall be zero have yet to be established.

As the aerodynamic moment must be equilibrated by the inertia couple and as the direction of the aerodynamic moment vector is fixed by the air flow over the airplane or model, the inertia couple vector has the same directions in both cases.

Thus, if the equations for equality of the inertia couple and aerodynamic moment in one plane through the spin axis be satisfied, the components of the resultant moments in all other planes will likewise sum up to zero and all the conditions for a

steady helical motion will have been satisfied. During steady motion, the inertia couple is a reaction couple due to forced rotation about an axis other than a principal one. For a set of components, which must not be zero, corresponding to any one plane through the spin axis, the following equation holds

$$\frac{P}{P_m} \frac{\omega^2}{\omega_m^2} = \left(\frac{l}{l_m}\right)^2 \left(\frac{V}{V_m}\right)^2 \left(\frac{l}{l_m}\right), \quad (7)$$

P and P_m are the products of inertia for the plane in which the components were taken. The product of inertia taken as designated in Figure 1, corresponds to moment components parallel to the $i j$ plane. The left side of the equation expresses the ratio of the centrifugal couples while the right side gives the ratio of the aerodynamic moments. Introducing the ratios derived above, it is found that

$$\frac{P}{P_m} = \frac{l}{N^5} \quad (8)$$

Hence it may be concluded that at corresponding points the momental ellipsoid of the model must be similar in shape and parallel in attitude to that of the full size airplane and have a linear scale ratio to it of N^5 . The model must be effectively an exact model, that is, one having the mass equivalent of the exact model (Reference 1).

PART II.

Mass Distribution for any Motion

The problem may now be generalized. It will be shown that a model so balanced may be used to simulate all no thrust power maneuvers and that equations (4) and (5) are applicable thereto.

It may be assumed to begin with that at some instant (1), (4), and (5) are true and that the gravity vectors for the model and the airplane are similarly located. This assumption merely presupposes corresponding initial conditions according to (1), (4), and (5).

The forces and moments are similarly located, and as before the force and moment diagrams must be similar. This means of course, the accelerating forces and couples bear the proportionalities of the diagrams and are similarly located. By equating the ratios of representative vectors in the two diagrams, it is found that

$$\begin{aligned}
 \frac{F}{F_m} &= \left(\frac{M a}{M_m a_m} \right) = \frac{M g}{M_m g} = \frac{1}{N^2}, \\
 a &= a_m, \\
 \text{and} \quad \frac{F l}{F_m l_m} &= \frac{I \alpha}{I_m \alpha_m} = \frac{\alpha}{N^2 \alpha_m}, \\
 \alpha &= N \alpha_m,
 \end{aligned}
 \tag{10}$$

$F_m = FN^2$

where I is the moment of inertia for the instantaneous axis about which the mass is undergoing an angular acceleration α ;

F is the accelerating force through the center of gravity of the mass which is being given a linear acceleration a ; l is a representative length on the force diagram and hence the product $F l$ may be used as representative of the moment vector diagram. During the increments of time Δt and Δt_m the motion will be, to the first degree of approximation, similar steady helical motions. Hence the displacement increments of the mass particles will be

$$\Delta d_m = N \Delta d \quad (11)$$

in which d is either a linear or circular ($l\omega$) displacement.

Dividing (11) by (4) or (5) gives the equation

$$\sqrt{N} \Delta t = \Delta t_m \quad (12)$$

The new velocities, accelerations and positions at the end of the time intervals fulfill the conditions previously assumed.

$$V_{\Delta t} = V + \Delta V = V + a \Delta t \quad (13)$$

$$V_{\Delta t_m} = V_m + \Delta V_m = \sqrt{N} V + \sqrt{N} a \Delta t \quad (14)$$

Hence

$$\frac{V_{\Delta t}}{V_{\Delta t_m}} = \frac{1}{\sqrt{N}} \quad \text{or} \quad V_{\Delta t} = \frac{V_{\Delta t_m}}{\sqrt{N}} \quad (15)$$

In like manner it may be shown that all the other conditions will repeat themselves. Thus, equations (4) and (5) completely correlate, neglecting for scale effect, the relationships between the motion of an airplane maneuvering under the

action of gravity alone and that of its model which has an equivalent quantity and distribution of mass.

PART III.

Obtaining the Desired Mass Distribution

A model has an equivalent quantity of mass if this quantity satisfies equation $M = M_m/N^3$.

The criterions for equivalent distributions of mass in a model may be stated as follows:

The model must have a center of gravity which is similarly located to that of the modeled body. It must have a momental ellipsoid at its center of gravity which is an N^5 scaled image of the momental ellipsoid at the center of gravity of the modeled body.

The ellipsoids must have similar attitudes relative to the shapes of the body and its model.

An exact model obviously satisfies the above conditions. However, to build a model geometrically scaled down in mass density distribution would be difficult, impractical, and unnecessary. It is only necessary to build a light model and so load it as to obtain the desired quantity and distribution of mass.

Let it be assumed first, that a light N^{th} scale model of mass M_3 has been built; second, that the mass M_1 , of the full size airplane is known; and third, that the expressions for their momental ellipsoids Φ and Ψ at corresponding points

(say the c.g. of the full sized airplane and the corresponding point in the model) have been computed (Reference 2). Figure 2 is a sketch of the momental ellipsoid for a typical airplane.

Let I_1 and I_3 be the moments of inertia for representative axes of the airplane and light model, respectively.

Figure 3 represents, superimposed upon each other, a light model whose center of gravity is (O_3) and an exact model whose center of gravity is (O_2) . (O_4) is the center of gravity of a load (M_4) which is to be so disposed as to bring the center of gravity of the light model to O_2 and to make its momental ellipsoid identical with that of the exact model. The exact model has a mass $N^3 M_1$ and moments of inertia $N^5 I$ at O_2 . The position, mass and momental ellipsoid (θ_2) of M_4 at O_2 are readily computed.

They are

$$M_4 = N^3 M_1 - M_3 \quad (16)$$

$$d = \overline{O_2 O_4} = \frac{M_3 (\overline{O_2 O_3})}{N^3 M_1 - M_3} \quad (17)$$

$$\theta_2 = N^5 \psi - \phi \quad (18)$$

To determine the shape and attitude of M_4 it is best to compute its momental ellipsoid (θ_4) at O_4 .

Let

$$\begin{aligned} \frac{1}{r_2^2} = N^5 \psi &= A_2 \alpha^2 + B_2 \beta^2 + C_2 \gamma^2 - 2D_2 \alpha\beta - 2E_2 \alpha\gamma - 2F_2 \beta\gamma \\ &= N^5 I_1 \end{aligned} \quad (19)$$

$$\text{and } \frac{1}{r_3^2} = \phi = A_3 \alpha^2 + B_3 \beta^2 + C_3 \gamma^2 - 2D_3 \alpha\beta - 2E_3 \alpha\gamma - 2F_3 \beta\gamma = I_3 \quad (20)$$

Hence

$$\begin{aligned} \theta_2 = N^5 \psi - \Phi = & (A_2' - A_3) \alpha^2 + (B_2 - B_3) \beta^2 + (C_2 - C_3) \gamma^2 \\ & - 2 (D_2 - D_3) \alpha \beta - 2 (E_2 - E_3) \alpha \gamma - \\ & - 2 (F_2 - F_3) \beta \gamma \end{aligned} \quad (21)$$

α , β and γ are the direction cosines with the usual reference axes taken for an airplane (Figure 1). r_2 and r_3 are the radii vectors of the ellipsoids. Again, let the direction cosines of the line $\overline{O_2 O_3}$ be (l, m, n) while (l_1, m_1, n_1) , (l_2, m_2, n_2) - - - - - (l_6, m_6, n_6) are the direction cosines for six arbitrary axes through O_4 . The moments of inertia for these axes are obtained by subtracting from the corresponding moments of inertia at O_2 the following expressions:

$$\begin{aligned} & M_4 d^2 \sin^2 \cos^{-1} (ll_1 + mm_1 + nn_1) & (22) \\ & M_4 d^2 \sin^2 \cos^{-1} (ll_2 + mm_2 + nn_2) \\ & - - - - - \text{etc.} - - - - - \\ & M_4 d^2 \sin^2 \cos^{-1} (ll_6 + mm_6 + nn_6) \end{aligned}$$

This will give six equations of the type

$$\begin{aligned} \theta (l_1, m_1, n_1) - M_4 d^2 \sin^2 \cos^{-1} (ll_1 + mm_1 + nn_1) & (23) \\ = A_4 l_1^2 + B_4 m_1^2 + C_4 n_1^2 - 2D_4 l_1 m_1 - 2E_4 l_1 n_1 - 2F_4 m_1 n_1 \end{aligned}$$

in which A_4, B_4, C_4 - - - - - $-2E_4$ are the coefficients of the momental ellipsoid (e_4) of M_4 at O_4 with the reference axes translated to O_4 .

For simplicity, the six axes may be chosen by the direction cosines $(0, 0, 1)$, $(0, 1, 0)$, $(1, 0, 0)$, $(\frac{1}{2}\sqrt{2}, \frac{1}{2}\sqrt{2}, 0)$, $(\frac{1}{2}\sqrt{2}, 0, \frac{1}{2}\sqrt{2})$ and $(0, \frac{1}{2}\sqrt{2}, \frac{1}{2}\sqrt{2})$. When placed in the equations (23) six simultaneous equations containing the constants A_4, B_4, \dots, F_4 are obtained. On solving, it is found that

$$C_4 = C_2 - C_3 - M R^2 (1 - n^2) \tag{24}$$

$$B_4 = B_2 - B_3 - M R^2 (1 - m^2)$$

$$A_4 = A_2 - A_3 - M R^2 (1 - l^2)$$

$$D_4 = D_2 - D_3 - M R^2 l m$$

$$E_4 = E_2 - E_3 - M R^2 l n$$

$$F_4 = F_2 - F_3 - M R^2 m n$$

where

$$M R^2 = \frac{M_3^2 (O_2 O_3)^2}{M_1 N^3 - M_3}$$

The principal moments and axes of the ellipsoid may be computed from these coefficients. The airplane in general has a plane of symmetry, the X Z plane, and therefore D_4 and F_4 are zero while B_4 is a principal moment of inertia. The Y axis is a principal axis. The other two principal axes are in the X Z plane and make the angles H_1 and H_2 with the X axis; these angles are given by the equations

$$\tan 2 H_1 = \frac{2 E_4}{C_4 - A_4} \tag{25}$$

Substituting the direction cosines of the three principal axes in the equation for θ_4 , the three principal moments of inertia are obtained. They are

$$I_b = B_4 \quad (26)$$

$$I_a = A_4 \cos^2 H_1 - 2E_4 \cos H_1 \sin H_1 + C_4 \sin^2 H_1$$

$$I_c = A_4 \cos^2 H_2 - 2E_4 \cos H_2 \sin H_2 + C_4 \sin^2 H_2$$

The subscripts a, b, and c indicate the principal centroidal axes of M_4 .

It is necessary to state that the coefficients given by (24) will not always be those of a momental ellipsoid. Care must be taken in building the light model. The surface of Φ must not intersect that of $N^s \psi$ and therefore the mass of the light model should be kept as close to the desired c.g. (O_2) as possible. A_4 , B_4 , and C_4 must each be positive. No one of them must be greater than the sum of the other two and the expression $A_4 - \frac{E_4^2}{C_4}$ must be greater than zero.

There is considerable choice regarding the dimensions of M_4 . First a loading material with a mass density great enough to insure complete concealment must be chosen. This choice is chiefly influenced by the quantity of mass to be added. Having decided upon the density (ρ) a further choice as to the shape is present. Construction will be the chief guide here. As an example, the two simple blocks shown in Figure 4 will be considered.

The three centroidal principal moments of inertia of this system are

$$I_b = \frac{M_4}{12} (a^2 + c^2) + \frac{M_4}{4} (c + K)^2 \quad (27)$$

$$I_c = \frac{M_4}{12} (a^2 + b^2)$$

$$I_a = \frac{M_4}{12} (b^2 + c^2) + \frac{M_4}{4} (c + K)^2$$

$$M_4 = 2 a b c \rho$$

Solving for a , b , c , and K it is seen that

$$a = \sqrt{\frac{6}{M_4} (I_c + I_b - I_a)} \quad (28)$$

$$b = \sqrt{\frac{6}{M_4} (I_a + I_c - I_b)}$$

$$c = \frac{M_4}{2 a b \rho}$$

$$K = \sqrt{\frac{4I_a}{M_4} - \frac{1}{3} (c^2 + b^2) - c}$$

Inserting the values (26) into (28) the dimensions of the blocks are obtained. The light model when loaded with two blocks in a manner prescribed by the above results will then become effectively an exact model since it will have the equivalent quantity and distribution of mass of the airplane for which it was modeled.

It will often occur that the dimensions of the loading blocks as determined by the first solution will be such as to

destroy the aerodynamic characteristics of the model (see Appendix). In such cases the mass distribution of the light model must be altered by the addition of small masses in order to bring it closer to that required. The first solution will give a clue as to the proper disposition of these added masses. A second solution will then determine loading blocks which will be completely concealed within the model.

To determine the most desirable inertia characteristics for a given airplane shape, a model may be constructed with an adjustable loading, permitting an arbitrarily chosen mass distribution, and dropping tests made until a distribution is finally obtained which gives the model the most desired gravity performance. The useful load of the airplane might then be located to obtain a like distribution. For a distributed useful load the dimensions of the pattern of distribution could readily be computed from the inertia characteristics of the individual loads.

Conclusion

The maneuvers of a full scale airplane under the action of gravity alone may be completely simulated by a model which has been prepared to contain a mass quantity N^3 times the mass quantity of the full scale airplane; to have a center of gravity which is similarly located to that in the full scale airplane, to have a centroidal ellipsoid of inertia whose linear dimen-

sions are N^5 times those of the centroidal ellipsoid of the full scale airplane and whose attitude in the model is similar to that of the momental ellipsoid in the full scale airplane.

The simulation will be in accordance with the following equations:

$$V = V_m / \sqrt{N}$$

$$\omega = \omega_m \sqrt{N}$$

$$t = t_m / \sqrt{N}$$

$$l_m = N l$$

$$\omega_m = \frac{l}{\sqrt{N}} \omega$$

V and V_m are the linear velocities at homologous points of the paths, ω and ω_m the angular velocities at these points. l and l_m are representative dimensions of their paths while t and t_m are the times occupied in traversing homologous path increments.

These relations may be used to compute the velocities, the turns, the times and the distances for complete maneuvers, or homologous portions of maneuvers.

Definition of Symbols

PART I.

The subscript m designates symbols referring to the balanced model.

- N = scale ratio of model to airplane.
- V = linear velocity.
- ω = angular velocity.
- l = a representative linear dimension.
- M = mass.
- P = product of inertia.

PART II.

- F = force.
- a = linear acceleration.
- l = a representative length on force diagram.
- α = angular acceleration.
- t = time.
- Δd = displacement increment of mass particle.
- $M, a, N,$ and V as in I.

PART III.

The subscripts 1, 2, 3, and 4 designate the full scale airplane, exact model, light model, and loading mass, respectively.

- M_1 = mass of full scale airplane.
- M_3 = mass of light model.
- M_4 = mass of loading material.

PART III (Cont.)

- ψ = designation for momental ellipsoid of full scale airplane.
- ϕ = designation for momental ellipsoid of light model.
- I_1 = moments of inertia of full scale airplane.
- I_3 = moments of inertia of light model.
- O_2 = center of gravity of exact model.
- O_3 = center of gravity of light model.
- O_4 = center of gravity of M_4 .
- θ_2 = designation for momental ellipsoid of M_4 at O_2 .
- θ_4 = designation for momental ellipsoid of M_4 at O_4 .
- α, β, γ = direction cosines.
- l, m, n = direction cosines.
- A_2, B_2, C_2 = moments of inertia of exact model about XX, YY, and ZZ, respectively.
- D_2, E_2, F_2 = products of inertia of exact model for the planes XZ and YZ, XY and ZY, and YX and ZX.
- A_3, B_3, C_3 = moments of inertia of light model about XX, YY, and ZZ, respectively.
- D_3, E_3, F_3 = products of inertia of light model for the planes XZ and YZ, XY and ZY, and YX and ZX.
- A_4, B_4, C_4 = moments of inertia of M_4 with respect to reference axes translated to O_4 .
- D_4, E_4, F_4 = products of inertia of M_4 with respect to reference axes translated to O_4 .
- I_a, I_b, I_c = principal moments of inertia of M_4 .
- a, b, c, K = dimensions of M_4 .
- ρ = density of loading material.

References and Bibliography

- Reference 1. Zahm, A. F. : Periodic Stresses in Gyroscopic Bodies with Application to Air Screws. N.A.C.A. Technical Report No. 19 (1918).
- Reference 2. Green, M. W. : Measurement of the Moments of Inertia of Full Scale Airplanes. N.A.C.A. Technical Note No. 265 (1927).
- Reference 3. Ziwet, Alexander : Theoretical Mechanics. The Macmillan Company, New York (1914).
- Munk, Max M. : Comparing the Performance of
and : Geometrically Similar Air-
Warner, Edward P. : planes. N.A.C.A. Technical
Note No. 190 (1924).

A p p e n d i x

Procedure for the Construction and Loading of the Model

A light model is built with its mass content as close to the desired c.g. O_3 , as is possible. Its XZ plane must be a plane of symmetry. The coefficient of the momental ellipsoids of the light model and the full scale airplane must next be determined.

The coefficients D_1 , D_3 , F_1 , and F_3 of the equations (19) and (20) will be zero because of the plane of symmetry (the XZ plane). To determine the other coefficients it is necessary to measure the moments of inertia for four arbitrary axes (not in one plane) through O_3 in the light model and for four axes through the c.g. of the full scale airplane (References 2 and 3). The values are substituted in (19) and (20) and the coefficients determined.

Equations (16) and (17) will give the mass quantity and the position in the model of the center of gravity of the load M_4 . If the block shapes are chosen, equations (24), (25), (26), and (28) are to be used in the order indicated to determine the dimensions of the mass M_4 and the angles that the edges a , b , and c make with the reference axes of the model. b is parallel to the Y axis while a and c make the angles H_1 and H_2 with the X axis (Figure 5).

If other shapes are chosen the equation (20) must be changed accordingly. The equations (27) corresponding to the

particular shapes chosen must next be set down and the corresponding equations (28) obtained from them.

Problem

The following case is worked out to make clear the process of solving for the dimensions and position of the mass M_4 .

The data have been determined experimentally and are given as follows:

For the full scale airplane (O-2 observation),

$$A_1 = I_{xx} = 5090 \text{ slugs feet}^2$$

$$B_1 = I_{yy} = 4800 \text{ slugs feet}^2$$

$$C_1 = I_{zz} = 8260 \text{ slugs feet}^2$$

$$I_{xz} = 5370 \text{ slugs feet}^2$$

where the \overline{XZ} axis is inclined $+7^\circ 45'$ to the \overline{XX} axis.

$$M_1 = \frac{W}{g} = \frac{4676}{32.2} = 145.2 \text{ slugs.}$$

For the light model,

$$A_3 = I_{xx} = .0140 \text{ slugs feet}^2$$

$$B_3 = I_{yy} = .0130 \text{ slugs feet}^2$$

$$C_3 = I_{zz} = .0240 \text{ slugs feet}^2$$

$$I_{xz} = .0180 \text{ slugs feet}^2$$

where the \overline{XZ} axis is inclined $+45^\circ$ to the \overline{XX} axis.

$$M_3 = \frac{W}{g} = \frac{1.15}{32.2} = .0357 \text{ slugs.}$$

$$N = \text{scale of model} = \frac{1}{12} \text{ full size.}$$

The ellipsoid of inertia for the full scale airplane is given by equation (19),

$$A_1 \alpha^2 + B_1 \beta^2 + C_1 \gamma^2 - 2E_1 \alpha \gamma = I_{xz}.$$

Substituting and solving for E_1 ,

$$5090 \cos^2 7.75^\circ + 8260 \cos^2 (90 - 7.75)^\circ - 2E_1 \cos 7.75^\circ \cos (90 - 7.75)^\circ = 5370$$

$$\underline{E_1} = \underline{-827.5}$$

The ellipsoid of inertia for the light model is given by equation (20),

$$A_3 \alpha^2 + B_3 \beta^2 + C_3 \gamma^2 - 2E_3 \alpha \gamma = I_{xz}.$$

Substituting and solving for E_3 ,

$$.0140 \cos^2 45^\circ + .0240 \cos^2 45^\circ - 2E_3 \cos^2 45^\circ = .0180$$

$$\underline{E_3} = \underline{.0005}$$

The mass quantity of the load M_4 is

$$\begin{aligned} \underline{M_4} &= N^3 M_1 - M_3 & (16) \\ &= \frac{145.2}{12^3} - .0357 \\ &= \underline{.0482 \text{ slugs}} \end{aligned}$$

The position of M_4 is

$$d = \overline{O_2 O_4} = \frac{M_3 (\overline{O_2 O_3})}{M_4} \quad (17)$$

where $\overline{O_2 O_3}$ has been found to be .2695 ft.

$$\begin{aligned} \therefore \underline{a} &= \frac{.0357 \times .2695}{.0482} \\ &= \underline{.200 \text{ ft.}} \end{aligned}$$

The coefficients of the ellipsoid of inertia of M_4 are given by equation (24),

$$C_4 = N^5 C_1 - C_3 - MR^2 (1 - n^2)$$

where

$$MR^2 = \frac{M_3^2 (\overline{O_3 O_5})^2}{M_1 N^3 - M_3} = .00177$$

and n is the direction cosine of the line $\overline{O_2 O_3}$ with respect to the \overline{ZZ} axis, found by measurement to be $\cos 99.6^\circ = -.1668$.

$$\begin{aligned} \therefore \underline{C_4} &= \left(\frac{1}{12}\right)^5 \times 8260 - .0240 - .00177 (1 - .1668^2) \\ &= \underline{.00738} \end{aligned}$$

$$B_4 = N^5 B_1 - B_3 - MR^2 (1 - m^2)$$

where m is the direction cosine of the line $\overline{O_2 O_3}$ with respect to the \overline{YY} axis (1.00).

$$\begin{aligned} \therefore \underline{B_4} &= \left(\frac{1}{12}\right)^5 \times 4800 - .0130 - .00177 \\ &= \underline{.00449} \end{aligned}$$

$$A_4 = N^5 A_1 - A_3 - MR^2 (1 - l^2)$$

where l is the direction cosine of the line $\overline{O_2 O_3}$ with respect to \overline{XX} axis ($\cos - 9.6^\circ = .986$).

$$\begin{aligned} \therefore \underline{A_4} &= \left(\frac{1}{12}\right)^5 \times 5090 - .0140 - .00177 (1 - .986^2) \\ &= \underline{.00640} \end{aligned}$$

$$\begin{aligned}
 \underline{E}_4 &= N^5 E_1 - E_3 - MR^2 (1/n) \\
 &= \left(\frac{1}{12}\right)^5 \times (-827.5) - .0005 - .00177 \times .986 \times .1668 \\
 &= \underline{-.00354}
 \end{aligned}$$

The direction of the principal axis of M_4 is given by equation (25),

$$\begin{aligned}
 \tan 2 H_2 &= \frac{2 E_4}{C_4 - A_4} \\
 &= \frac{2 \times (-.00354)}{.00738 - .00640} = \frac{-.00708}{.00098} = -7.22
 \end{aligned}$$

$$2 H_2 = \tan^{-1} (-7.22) = -82.11^\circ$$

$$\underline{H_2 = -41.06^\circ}$$

from which

$$\underline{H_1 = 90^\circ - 41.06^\circ = 48.94^\circ}$$

I_a , I_b , and I_c , the three principal moments of inertia of M_4 at O_4 , are found from equations (26),

$$I_b = B_4 = .00449 \text{ slugs feet}^2$$

$$\begin{aligned}
 I_a &= A_4 \cos^2 H_1 - 2E_4 \cos H_1 \sin H_1 + C_4 \sin^2 H_1 \\
 &= .0064 \times .6567^2 + .00708 \times .6567 \times .7541 + \\
 &\quad + .00738 \times .7541^2 \\
 &= .01046 \text{ slugs feet}^2
 \end{aligned}$$

$$\begin{aligned}
 I_c &= A_4 \cos^2 H_2 - 2E_4 \cos H_2 \sin H_2 + C_4 \sin^2 H_2 \\
 &= .0064 \times .7541^2 + .00351 + .00738 \times .6567^2 \\
 &= \underline{.01033} \text{ slugs feet}^2
 \end{aligned}$$

The dimensions of the mass M_4 are found from equations (28),

$$\begin{aligned}
 a &= \sqrt{\frac{6}{M_4} (I_c + I_b - I_a)} \\
 &= \sqrt{\frac{6}{.0482} (.01033 + .00449 - .01046)} \\
 &= \underline{.736 \text{ ft.}} \\
 b &= \sqrt{\frac{6}{M_4} (I_a + I_c - I_b)} \\
 &= \sqrt{\frac{6}{.0482} (.01046 + .01033 - .00449)} \\
 &= \underline{1.43 \text{ ft.}} \\
 c &= \frac{M_4}{2 a b \rho} = \frac{.0482}{2 \times .736 \times 1.43 \times \rho}
 \end{aligned}$$

If lead is used as the loading material, ρ can be taken as $\frac{11.4 \times 62.4}{32.2}$ slugs per cu.ft., and c becomes .00104 ft.

$$\begin{aligned}
 k &= \sqrt{\frac{4I_a}{M_4} - \frac{1}{3} (c^2 + b^2)} - c \\
 &= \sqrt{\frac{4 \times .01046}{.0482} - \frac{1}{3} (.00104^2 + 1.43^2)} - .00104 \\
 &= \underline{.430 \text{ ft.}}
 \end{aligned}$$

The solution has given us two sheets of lead .736 feet high, 1.43 feet wide, and .00104 feet thick spaced .430 feet apart. These sheets, if mounted on the model given, will project out of the sides of the fuselage and greatly affect the aerodynamic characteristics of the model. To obviate this

difficulty it will be necessary to alter the mass distribution of the light model and try the solution again. The above solution suggests that small masses placed within the wings near the tips at the leading edge will change the inertia characteristics in the desired direction. When this is done, the four moments of inertia for the altered model are determined and a second solution made. If the blocks are too thin, a less dense material will be used.

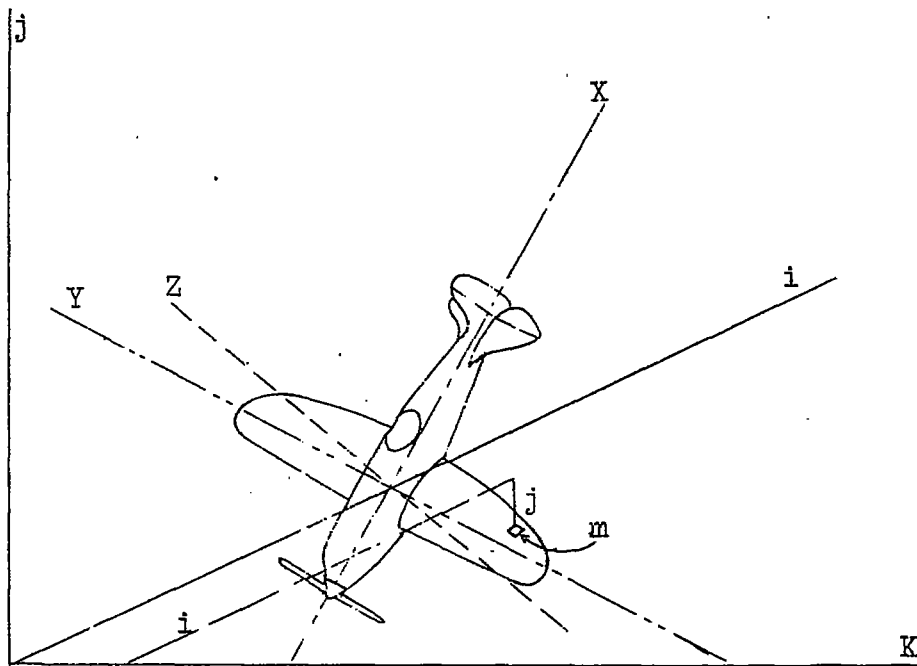

$$P = \sum m_{ij}$$

Fig.1.

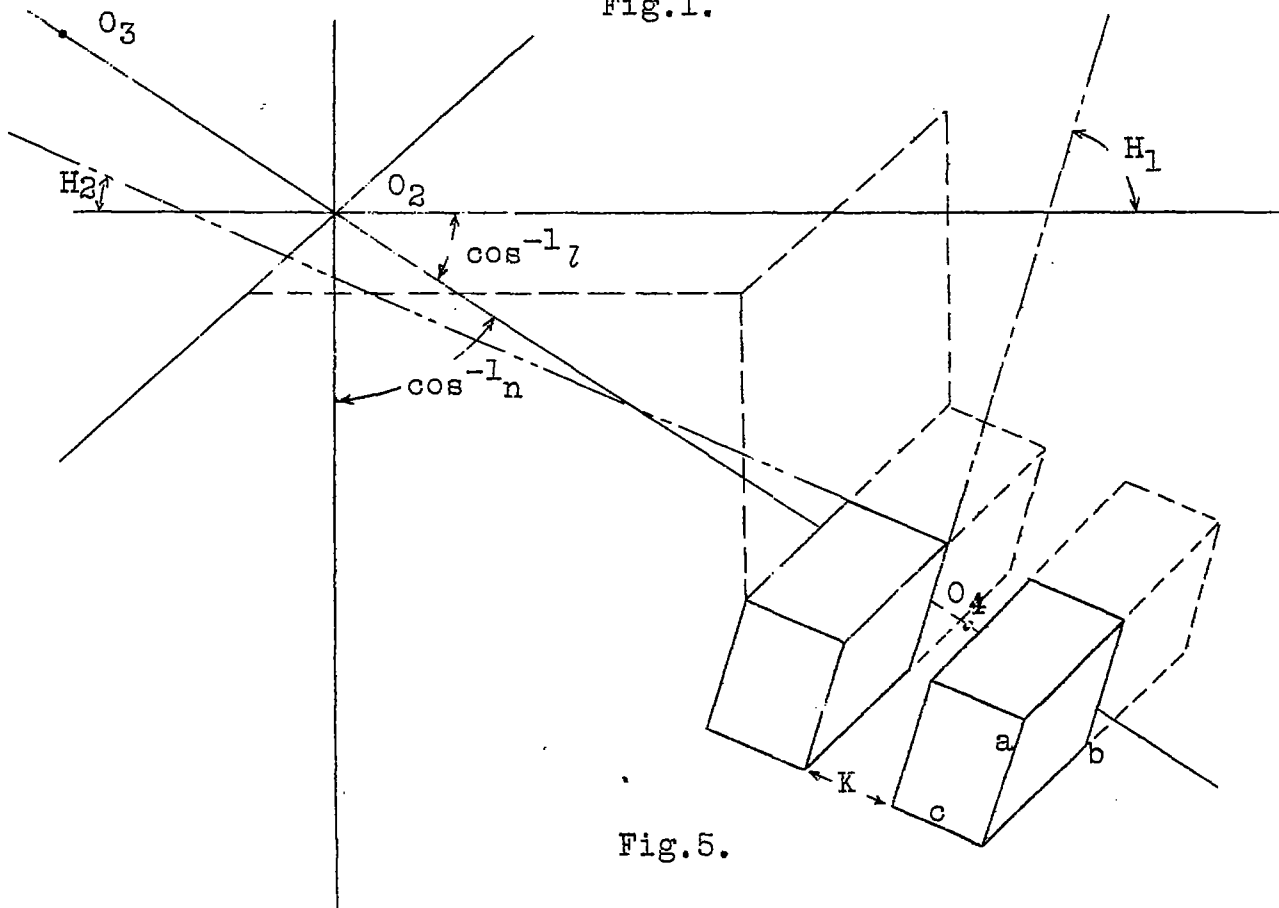
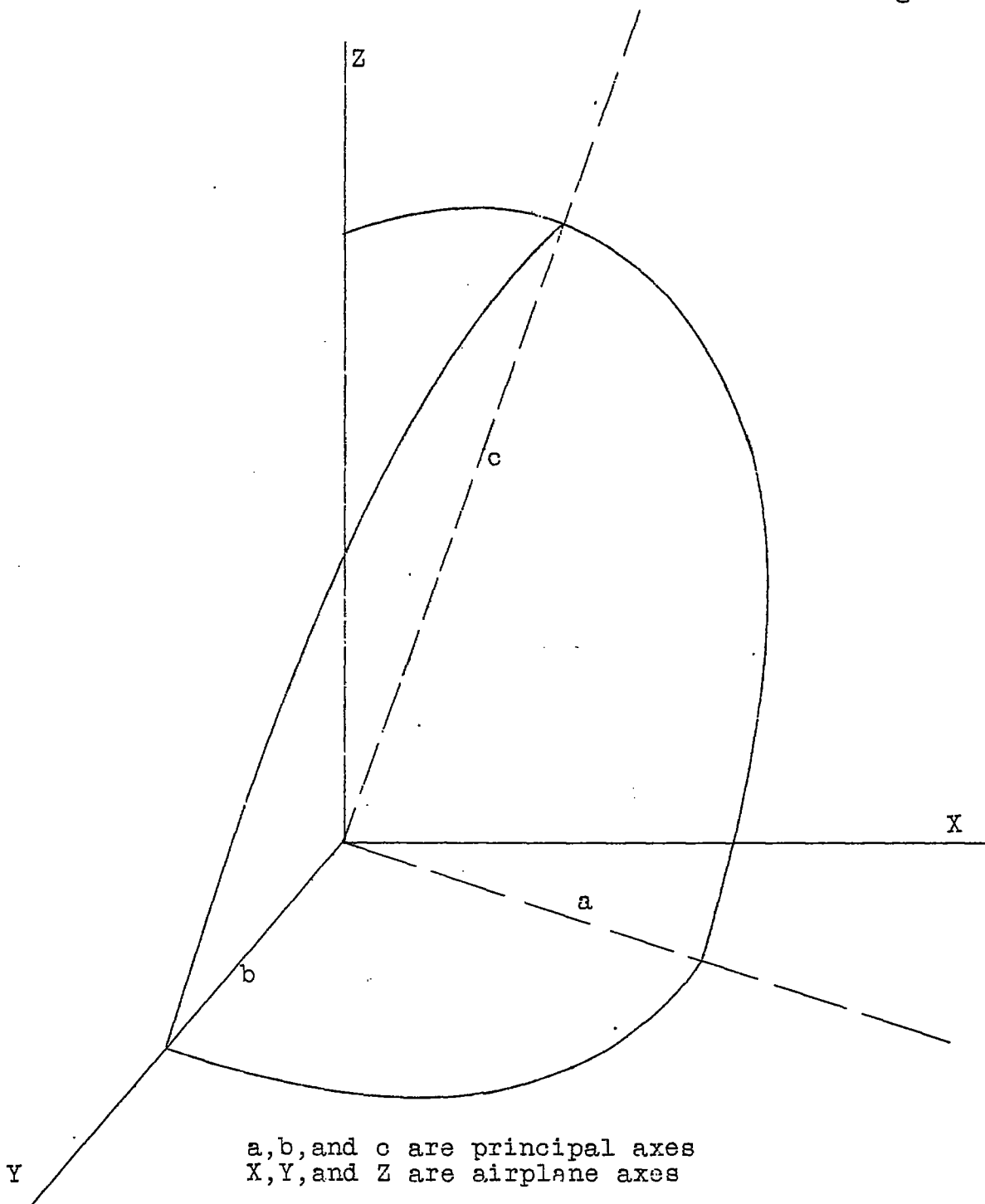

Fig.5.



a,b, and c are principal axes
X,Y, and Z are airplane axes

Fig.2 Quadrant of momental ellipsoid.

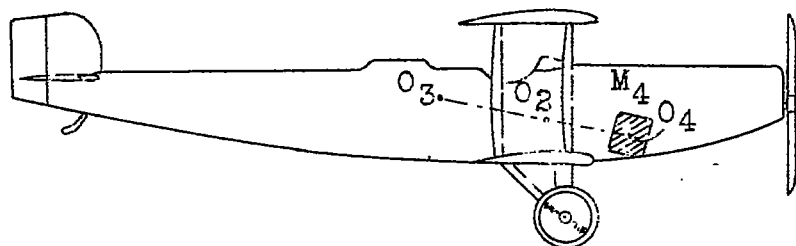

Fig.3

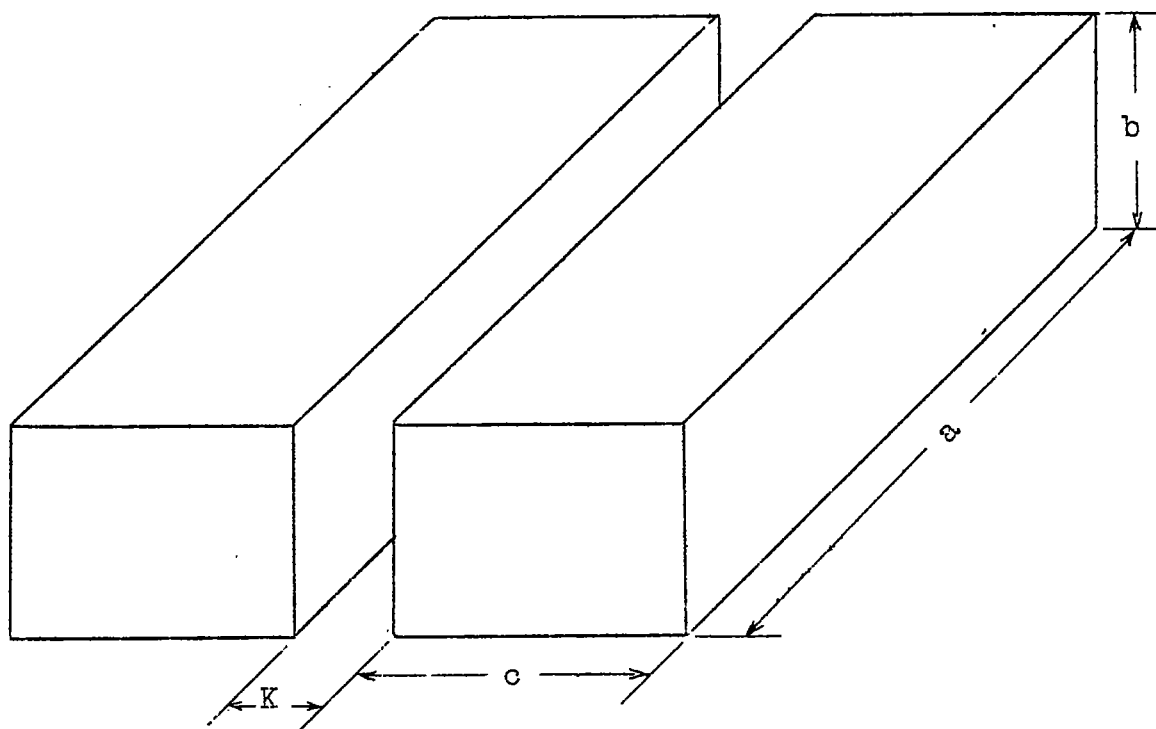

Fig.4