

TOP SECRET

Library P.M.A.L.

TECHNICAL NOTES

NATIONAL ADVISORY COMMITTEE FOR AERONAUTICS

No. 402

THE EFFECTIVENESS OF A DOUBLE-STEM INJECTION VALVE
IN CONTROLLING COMBUSTION IN A COMPRESSION-IGNITION ENGINE

By J. A. Spanogle and E. G. Whitney
Langley Memorial Aeronautical Laboratory

LIBRARY

Returned to
Members of the Langley
Memorial Aeronautical
Laboratory.

Washington
December, 1931



NATIONAL ADVISORY COMMITTEE FOR AERONAUTICS

TECHNICAL NOTE NO. 402

THE EFFECTIVENESS OF A DOUBLE-STEM INJECTION
VALVE IN CONTROLLING COMBUSTION IN A
COMPRESSION-IGNITION ENGINE

By J. A. Spanogle and E. G. Whitney

Summary

An investigation has been made to determine to what extent the rates of combustion in a compression-ignition engine can be controlled by varying the rates of fuel injection. A cam-operated fuel-injection pump was used with a double-stem automatic injection valve, whose concentric spring-loaded lapped stems permitted the successive uncovering of two independent sets of orifices at preadjusted pressures. Fuel sprays were injected into the vertical-disk form of combustion chamber of a single-cylinder test engine. Nozzles were used that gave fuel distribution similar to that obtained from a single-stem valve. For various injection rates, comparison tests were made of engine performance using both single-stem and double-stem valves.

The tests showed that: (1) the double-stem valve operated satisfactorily under all normal injection conditions; (2) the rate of injection has a definite influence on the rate of combustion; (3) the engine performance with the double-stem valve was inferior to that obtained with a single-stem valve; (4) the control of injection rates permitted by an injection valve of two stages of discharge is not sufficient to effect the desired rates of combustion.

Introduction

For an engine of given dimensions, known volumetric efficiency, rate of heat losses, and known heat value of

the fuel burned, instantaneous values of pressure existing in the cylinder can be computed throughout the working cycle for any assumed instantaneous rates of combustion. The area included within the pressure-volume diagram is a measure of the useful work obtained from the fuel burned and consequently indicative of the cycle efficiency. For a given total quantity of fuel burned, the area of the diagram can be made to vary widely by assuming different rates of combustion, and one combination of rates of combustion exists that will give optimum efficiency. Tests indicate that in a compression-ignition engine, combustion should be initiated before injection is completed (see reference 1); therefore, the rate at which fuel is burned should be, in part at least, a function of the rate of fuel injection. Consequently, the possibility should exist of controlling combustion with the injection system and checking the effect on the indicator card.

For any internal combustion engine, maximum efficiency would be obtained by burning the entire fuel charge at constant volume. In a compression-ignition engine of 450 pounds per square inch compression pressure, constant volume combustion would result in explosion pressures exceeding 1,200 pounds per square inch, which would necessitate heavier engine parts than used in conventional aircraft engines or more highly stressed parts for equal weights. Since the maintenance of engine weight and stresses at minimum values is of primary importance, a practical limit of 800 pounds per square inch for peak pressures was established for this investigation. Rates of combustion required to produce the optimum cycle efficiency without exceeding this imposed maximum pressure value were computed and a cam designed and built into a pump to displace fuel at these theoretical rates which were corrected for compressibility of the fuel, injection lag, and ignition lag. Attempts made to produce the theoretical rates of combustion by injecting with this pump and a single-stem automatic injection valve with single-orifice or multicorifice nozzles were unsuccessful and seemed to indicate the inadequacy of one automatic valve with fixed orifice area to properly atomize and distribute fuel at the desired rates without a range of pressures wider than could be accommodated by the injection system. The use of two valves or one valve employing some means of automatically varying the discharge area offered attractive possibilities in providing a wider range of injection rates with the available pressure range.

Double injection has been tried by other investigators. The use of two valves in conjunction with an auxiliary vaporizer or hot bulb to obtain automatic ignition at low compression ratios is described by E. K. Butler. (See reference 2.) Several investigators in Germany have initiated combustion of coal-tar products of high ignition points by injecting 5 per cent of ignition oil into the cylinder immediately preceding injection of the coal-tar product. (See reference 3.) Bird describes the "Sabathé" type injection valve, used with air injection to give two successive discharges, in an effort to depart from the constant-volume cycle. (See reference 4.) None of the investigations, however, shows the effectiveness of double injection in controlling combustion; for this reason this investigation was undertaken.

The development of a suitable injection valve of automatically-variable discharge area and the testing of its effectiveness in controlling combustion in a compression-ignition test engine were undertaken at the Langley Memorial Aeronautical Laboratory during the two-year period included from the middle of 1928 to the middle of 1930.

Apparatus and Tests

Preliminary considerations.-- The engine chosen for this investigation was the Universal test engine, using the N.A.C.A. No. 4 vertical-disk form of combustion chamber fully described in reference 5. As therein mentioned, a multiorifice nozzle is required to obtain the optimum fuel distribution in this cylinder head. A similar multiorifice arrangement, in which the orifices are successively uncovered to permit discharge, might reasonably be expected to give satisfactory results for a valve whose discharge area was automatically varied. Consideration of the combustion rates desired and of the mechanical aspects involved led to the design of a multiorifice valve opening in two stages. The increase in injection pressure is the actuating force that uncovers the sets of orifices.

The determination of the desired combustion rates was made from the theoretical indicator card of Figure 1. This card represents the most efficient operating cycle

for the 5-inch by 7-inch cylinder under the assumed conditions. Combustion of approximately one-fourth full-load charge is required at constant volume to give a pressure at T.C. of 800 pounds per square inch. Continuation of combustion A.T.C. is assumed to be at such a rate as to maintain the maximum pressure constant until all the fuel is burned. The desirable point for the start of burning was considered to be 16° B.T.C. (labelled on Figure 1 "ignition"), giving a calculated value for the start of injection of 40° B.T.C.

To obtain the rates of combustion necessary to give the theoretical indicator card, the injection valve should be able to accommodate a considerable increase in discharge rate after injecting one-fourth of the full-load fuel charge. A constantly increasing discharge area would provide the best means of taking care of these desired increasing injection rates. However, mechanical problems in construction and operation of such a valve that would give suitable spray distribution in the specified combustion chamber were so great that it was decided to design a valve having only two stages of discharge area. The first stage would provide for the small primary quantity of fuel to be burned B.T.C. and the addition of the second would provide for the larger discharge and higher rates required to maintain the constant pressure. Each discharge area would comprise several orifices of number, size, and location to give optimum fuel distribution.

Development of Double-Stem Valve

To satisfy all the requirements of such an experimental valve, twelve different designs were considered, each with its peculiar advantages and limitations. These types included: various combinations of two spring-loaded stems arranged coaxially, side by side, or at an angle, each stem controlling one part of injection; one double spring-loaded stem where the two successive stages of stem lift successively uncovered two sets of orifices; a combination of one spring-loaded stem and one diaphragm-loaded valve sleeve; a combination of one spring-loaded stem and one sleeve extended in tension by oil pressure; and one spring-loaded stem whose lift caused rotation of an orifice-controlling element. Of all types mentioned, the one employing two concentric spring-loaded lapped stems was chosen as best fulfilling all requirements.

The final design is shown in section in Figure 2. The main body carries the oil inlet passage and the lapped stems; the upper part is bored to accommodate the stem springs, threaded inside to take an inner spring-adjusting nut, and slotted and threaded outside to carry the adjusting nuts controlling the outer stem stop as well as those for the outer spring-adjusting collar, and a lock nut for the inner spring-adjusting nut. The valve-body adapter clamps the nozzle against the body and adapts the valve to an 18-millimeter spark-plug hole. The outer stem is hollow, lapped outside to fit the valve body and inside to fit the inner stem. Adjustable springs hold the valve stems against the nozzle where the oil seal is made by a flat lapped seat on either stem. The flat seat was adopted to permit the use of small stem lifts to give the required oil-flow passage. Adjustable stem stops are provided to limit the motion of the two stems to the desired lift.

The nozzle, detailed as D-1 in Figure 3, contains an inner well from which were drilled seven orifices of the sizes and at the angles which at the time were thought to give the best distribution in the N.A.C.A. No. 4 cylinder head. Admission and cut-off of fuel to the well are controlled by the inner stem which forms a circular seat 0.007 inch wide around the outer rim of the well. This seat width was chosen to give a 10,000-pound per square inch static seat stress at 2,000 pounds per square inch valve-opening pressure, this stress having been found desirable for satisfactory sealing against leakage. Just outside the inner stem seat were drilled two 1/64-inch holes; each one leads to two small orifices through which are discharged the small quantities of fuel to be burned at constant volume. Admission and cut-off to these orifices are controlled by the outer stem which seals with a flat ring seat 0.008 inch wide just outside the 1/64-inch drilled leads. A locating pin to fit in a slot in one side of the nozzle insures that the nozzle is always assembled with the same angular relation to the valve-body adapter. This facilitates assembly of the valve in the cylinder head with the spray in the proper plane. The design provides for the interchange of nozzles to adapt the spray to different shapes of combustion chamber.

The valve functions as follows: oil enters from the side and passes through the drilled hole in the body to the annular space surrounding the outer stem just above the nozzle. The force created by the pressure acting on the exposed surface of the outer stem causes the latter

to lift against its spring load and allows the oil access to the primary orifices. Simultaneously the oil pressure acts upon the exposed lifting surface of the inner stem, tending to force it from its seat. Injection occurs through the primary orifices until the increasing oil pressure becomes sufficiently high to overcome the spring force holding the inner stem on its seat, at which time the latter lifts and allows the oil to discharge through the additional seven orifices. By adjusting the spring forces acting on the two stems, the proportion of the fuel injected through the primary orifices may be varied.

The lifts of the stems were calculated to give a flow area through the seat restriction of four times the nozzle orifice-discharge area, to minimize pressure loss due to throttling. This ratio fixed the lift for the outer stem at 0.0097 inch and for the inner stem at 0.0135 inch.

Considerations of permissible stem diameters, available hydraulic lifting areas, desired valve-opening pressures, available space for stem seats, mechanical limitations in constructing stem seats, static seat stress at the designed valve-opening pressure, and space limitations for accommodation of the springs, determined the spring loadings for the two stems. They were 35 pounds for the inner spring at an opening pressure of 4,000 pounds per square inch and 40 pounds for the outer spring at an opening pressure of 2,000 pounds per square inch. Stresses in the springs were kept sufficiently low to allow satisfactory operation at valve-opening pressures of twice the designed values.

The stem loadings determine the rapidity with which the stems will close for any rate-of-pressure drop, i.e., the sharpness of cut-off. A sharp cut-off without bouncing of the stem is required to prevent dribbling, with its attendant late burning of the last entering fuel and resultant deleterious effect on combustion efficiency. Assuming no stem friction and an instantaneous pressure drop in the injection line, these designed forces would close the stems from their calculated maximum lifts in less than $1\frac{1}{2}$ crank-angle degrees at an engine speed of 1,500 r.p.m.

Test Procedure

The completed valve was given a preliminary test by injecting into the atmosphere; fuel was supplied by a cam-operated plunger pump having a variable rate of plunger displacement, and the spray was observed with an oscilloscope. (See reference 6.) Opening pressures of the two stems were then varied over the adjustable range and the functioning observed at various injection rates.

In order to study the sprays issuing successively from the primary and main orifices and the time interval between the first appearances of the primary and main jets, attempts were made to photograph sprays from the fuel valve by means of the N.A.C.A. high-speed photographic equipment. (See reference 7.) However, as this apparatus supplies oil to the valve at a constant pressure, no combinations of valve-opening pressures on the primary and main stems of the valve would permit sufficient time to elapse between successive stem lifts to give measurable double injection. The greatest time interval photographed between starts of the two stages of injection was less than one half-thousandth second.

The valve was next installed in the vertical-disk form combustion chamber of the single-cylinder test engine for a preliminary test under engine power. Nozzle No. D-1 (fig. 3) was used. This nozzle was designed to have the same total discharge area as had the best performing nozzle of previous experiments with single-stem injection valves, but the size and angles of the individual orifices were not identical. To this resultant difference in fuel distribution within the combustion chamber the inferior performance of the engine with the double-stem valve was at first attributed. Two additional nozzles were consequently tested, so constructed as to give distribution similar to that from two of the best performing single-stem valve nozzles. These additional nozzles are shown in Figures 3 and 4. The D-2 nozzle of Figure 3 has the same size and number of orifices as the No. 9 nozzle described in reference 5, as well as identical angular relation between the sprays. The only difference is that the two outer or 0.008-inch orifices do not emanate from the central well but are directly supplied by individual wells leading to the space between the inner and outer valve-stem seats, so that they act as distributors

of the primary fuel. This arrangement directs the primary sprays so that their combustion should heat the relatively cool outer part of the combustion chamber prior to the combustion of the main sprays.

The third nozzle, D-3, constructed for use with the double-stem valve and illustrated in Figure 4, is similar to the single-stem valve nozzle designated E-8 in reference 8. It has two 0.005-inch orifices for primaries which inject vertically into the combustion chamber, whereas E-8 has two 0.007-inch orifices placed at an angle of 10° to the vertical - the size and arrangement of the six remaining orifices are identical. The reason for substituting the 0.005-inch orifices in D-3 for the 0.007-inch orifices of E-8 was to maintain more similar distribution of fuel. The proper size was determined by a consideration of the lower initial injection pressures of the double-stem valve and the longer duration of injection through the first-opened orifices. Calculations showed that the 0.005-inch orifices should permit the passage of a fuel quantity approximately equal to that through the 0.007-inch orifices of E-8. The arrangement of the primary orifices of this nozzle is such as to direct the sprays into the combustion chamber across the heads of the inlet and exhaust valves so that their combustion would create a superheated region into which the main jets must discharge.

Fuel was supplied to the valve by a cam-operated plunger pump. Two pump cams were used to explore a wide range of injection rates; their comparative rates of displacements are shown by the curves of Figure 5. The curve of No. 1 cam shows only the portion of the available displacement that was used in the tests; the curve extended would be a straight line indicating zero plunger displacement at zero crank degrees. The pump permitted control of the start and termination of pressure build-up in the plunger cylinder through the adjustment of the time of closing and opening of a poppet-type by-pass valve. By a change in the setting of the by-pass controls it was possible to investigate any displacement rate provided by the cam-plunger curve. In this investigation, tests were made with the start of fuel compression in the pump occurring at 225, 270, 285, 300, 360 and 400. These values, hereinafter called start settings, refer to the crank degrees indicated on the curve, and are reference numbers only; they should not be taken to mean the corresponding

point in the combustion cycle, as the angular relation between the pump cam and the crankshaft is variable for earlier or later injection as desired.

By the use of these nozzles and pump-displacement rates described, the effectiveness of the two-stem valve in improving engine performance and controlling the shape of the indicator card was investigated. Engine-operating temperatures of oil, water, and air were maintained constant at the standard test values and the engine speed was held at 1,500 r.p.m. With the pump-start control set to give the injection rates desired, the fuel quantity was adjusted to the maximum amount that would allow smokeless exhaust with just a trace of flame, and the injection timing was advanced far enough to cause a light knock. Power and economy data were recorded. Values of indicated mean-effective pressure were calculated from these data, assuming that the indicated mean-effective pressure equalled the sum of the brake and friction mean effective pressures.

The pressure-time card for the cycle was simultaneously taken with the Farnboro indicator, using the altered pressure element. (See reference 9.) The drum carrying the card was driven from the engine dynamometer shaft and the disk valve installed in the upper side hole of the cylinder head. For each condition of engine performance recorded, several time-pressure cards were taken to check their reproducibility. A sample card is shown in Figure 6; from this record the P-V card for the double-stem valve performance was taken shown in Figure 9.

This procedure was followed for each of the double-stem valve nozzles and over the complete range of injection rates available. The individual tests were then repeated with the single-stem valve, using the nozzles comparable from a distribution standpoint and maintaining the same standards of combustion conditions as evidenced by the exhaust and by the engine knock. Cards taken for all conditions were then transferred to the P-V basis for comparison with the theoretical card and with each other. A comparative maximum power test for the single-stem valve and the double-stem valve was included, together with a test of the single-stem valve to show the effect on the P-V card of advancing the injection beyond the point of chosen standard engine knock.

With the valves injecting into the atmosphere and the pump settings and timing reproduced, oscilloscope

determinations of the time of start and cut-off of injection were made for each condition of test. The oscilloscope, driven directly from the engine camshaft, permitted a direct determination of the start and stop of injection with respect to the piston position.

To determine the actual rates at which fuel was being introduced into the cylinder for each of the tested conditions, pump settings and timings were again reproduced and the fuel injected through the respective valves and nozzles into air at atmospheric pressure and temperature by a revolving cup whose timing in the cycle could be varied. This apparatus, described in reference 10, enables the determination of the increment of fuel injected for each crank degree over the entire injection period. Instantaneous injection rates in fuel per cycle per crank degree were calculated from the data so obtained and were plotted against crank degrees.

Results and Discussion

The preliminary tests showed the double-stem valve to operate quite satisfactorily with the cam-operated plunger pump. The stems functioned without mutual interference and the flat seats gave a good cut-off with no leakage or dribble. There was, however, a greater tendency for the primary orifices to clog than evidenced by previous experience with holes of the same diameter radiating from a larger though shallower supply well. Careful cleaning of the fuel obviated this difficulty.

For a given setting of spring tensions on the two stems, the interval between starts of primary and main injections was dependent upon the rate of pump-plunger displacement. The slower the rate-of-pressure rise, the longer the time interval between the opening of the primary and of the main stems, and hence the greater the proportion of total fuel injected through the primary orifices. As the rate of pump displacement was increased, the lag between the lifting of the two stems decreased until, at a rate of pump-plunger displacement of between 10.0 and 10.5 cubic inches per second, the two valve stems lifted simultaneously, though set at a 2,000-pound per square inch difference in opening pressure. The closing of the two stems was always simultaneous, irrespective of valve-opening pressures or displacement rates.

The interval between successive stem lifts could be varied by changing the difference in tensions between the two springs. This control was most effective at low rates of pump displacement and was negligible at high rates. In all cases this range of control was narrow, as primary stem-opening pressures below 1,500 pounds per square inch gave undesirably poor atomization and distribution, and main stem-opening pressures above 5,000 pounds per square inch resulted in the development of injection pressures that produced undesirably high stresses in the valve and injection system.

When tested in the single-cylinder test engine, the valve operated normally. Engine performance, however, was inferior to that obtained with the single-stem valve. For the same injected maximum-power fuel quantity, the i.m.e.p. obtained was 11.5 per cent lower with the double-stem valve; furthermore, combustion was poorer, evidenced by black smoke and dull red flame. The maximum i.m.e.p. obtained with the double-stem valve was 114 pounds per square inch, contrasted to an i.m.e.p. of 129 pounds per square inch for a similar single-stem valve nozzle. The inferior performance of the engine with the double-stem valve and the inefficient combustion as indicated by the smoky and red exhaust were probably due to improper fuel distribution.

When used with the highest pump-displacement rates, the double-stem valve acted as a single-stem valve, discharge occurring from all orifices simultaneously, irrespective of the fact that the opening pressures of the two stems were adjusted to a difference of 2,000 pounds per square inch. Engine performance under the chosen standard of fuel quantity and knock, however, was still 11 per cent lower with the double-stem valve, due, perhaps, to the additional supply wells in the nozzle affecting the pressure, causing the discharge of the individual orifices.

The comparative indicator cards of engine performance with the single and double-stem valves at 400 start setting are shown plotted on the P-V basis in Figure 7. The single-stem valve used E-8 nozzle and the double-stem valve used its analogue, D-3 nozzle. As both stems of the double-stem valve lifted simultaneously at these injection rates, the resultant cards are quite similar, the higher pressures of the double-stem valve card being caused by a 2° earlier injection. In both cases, pres-

sure rise due to combustion is delayed until the piston has passed T.C. and started down on the expansion stroke, a condition found typical of the indicator cards taken with the single-stem valve. If the fuel were injected earlier, the engine would knock badly and the pressures would rise to undesirable values. This effect will be discussed later.

The corresponding instantaneous injection rates for the single and double-stem valve performances of Figure 7 are shown in Figure 8. The rates are somewhat greater for the double-stem valve, which partially accounts for the difference in the indicator cards. This dissimilarity in rates of injection is most likely a consequence of the difference between the injection pressure and discharge characteristics of the two nozzles considered, because the same pump and displacement rates were employed and similar orifices were used in the two nozzles.

It was hoped, by the use of the double-stem valve, to initiate combustion earlier by the ignition of a small well-atomized fuel quantity that would apply explosion pressures gradually early in the stroke and allow the remainder of the fuel to be burned efficiently within the time available with the more rapid combustion permissible later in the stroke. That this object could be accomplished to some extent is demonstrated by the cards of Figure 9. These show respective performances of the single and double-stem valves using a 360 start setting. With the single-stem valve it is seen that the pressure drops on the power stroke to 50 pounds per square inch below the compression pressure before it is allowable for combustion pressures to be built up. Earlier initiation of combustion would result in excessive knock. With the double-stem valve, however, the injection of a small primary charge 8° earlier, and addition of the main spray some 11° after this, enables the pressure to be maintained above the compression-pressure value and results in the card shown. However, the control of combustion is insufficient to permit of the pressure being built up to the T.C. value of the theoretical card without the pressures immediately A.T.C. reaching excessive values and the accompanying engine knock becoming prohibitive. Engine output in this case likewise favors the single-stem valve, which shows an i.m.e.p. of 109 pounds per square inch contrasted to 91 pounds per square inch for the double-stem valve.

The curves of Figure 10 show the effect of the double-stem valve in changing the injection rates at 360 start setting. The decrease in rate from 12° to 10° B.T.C. for the double-stem valve curve may be caused by bouncing of the outer stem before the opening of the inner stem. It will be noted that the maximum rate obtained with the double-stem valve is greater than that obtained with the single-stem valve.

Figures 11 and 12 show pressures developed at a lower rate of injection - 300 start setting. Figure 11 presents three cards taken with the same single-stem valve and nozzle with successively earlier timing of injection with respect to the piston position. Engine performance of the three tests was characterized by no change in brake power output, but with increasing knock of so heavy an intensity at the earliest injection condition that it was thought inadvisable to advance injection further. That the heavy knock was accompanied by a maximum pressure of but 620 pounds per square inch demonstrates the inability of the recording instrument to follow the extremely rapid shock pressures. (See reference 12.) The true shape of the card is, therefore, not recorded, which probably explains the successive 5 per cent decreases in card area as the injection is advanced. The upper and middle cards retain the characteristic of expansion along the compression line before combustion starts. The lower card, however, shows combustion initiated in time to build up pressure from T.C. (although at first but slightly faster than the adiabatic expansion of the compressed gas) with a resulting heavy knock and higher maximum cylinder pressure. Ricardo, Whatmough, and Janeway emphasize the necessity of control of rate-of-pressure rise in a spark-ignition engine to eliminate knock and rough running. (See reference 11.) In a spark-ignition engine, the rate-of-pressure build-up is limited to the rate-of-flame spread, and pressure rises of the order of 35 to 50 pounds per square inch per degree are considered. In a compression-ignition engine, rates-of-pressure rise several times those of the spark-ignition engine may be experienced. Whether the knock is due to rates-of-pressure rise or accelerations in rate-of-pressure rise can not be determined from the indicator cards. The fact remains that, with high injection rates, a destructive knock can be completely eliminated by retarding injection until a later time in the cycle, in which event neither the rate-

of-pressure rise nor the acceleration of the rate-of-pressure rise could be so high as with an earlier timing. The effect on performance, however, is to reduce the power output and cause late burning, as is evidenced by the flame and smoke in the exhaust.

The effect of using the double-stem injection valve with the medium rates of pump displacement is shown in Figure 12. In this case the injection of a small primary charge starting 13° earlier than the main spray builds up the pressure to 500 pounds per square inch at T.C. but allows it to drop below the compression-pressure value before combustion of the main charge. This condition indicates an insufficient flexibility of the injection system at these pumping rates. The primary discharge is too small to maintain the pressure A.T.C. and the main charge is so large as to require undesirably late injection to prevent too rapid initial pressure rise. Combustion in this case, however, allows an increase of 35 per cent in fuel charge over that allowable with the single-stem valve without smoking in the exhaust. The comparatively low initial rates of injection of the double-stem valve at this pump setting are shown in Figure 13.

Figure 14 shows cards at 225 start setting with single and double-stem valves. These cards are comparable only on a basis of pump displacement rates, since the fuel quantities were not equal, and for the double-stem valve card the injection was so far advanced as to produce bad knocking and rough running. The value of these cards lies in demonstrating the general form of card at low injection rates and the effect of low injection rates on the time of successive starts of primary and main fuel sprays.

The comparative effectiveness of the double-stem valve for the assumed operating condition and maximum power settings is demonstrated by Figure 15. Both cards show the same injection rates (360 start position). The maximum-power performance, however, has the injection start advanced 3° over those of the lower load and injection continues 10° longer to inject full-load fuel. The greatest difference in the cards lies in the higher pressures at all points along the expansion curve of the maximum-power card, indicating continued burning of a larger portion of the fuel during expansion. This in turn may be attributed to lack of efficiency in securing thorough mixture

of air and fuel, resulting in slow chemical union with the last air to be reached. Although the maximum power card shows an increase of 23 pounds per square inch i.m.e.p. over the condition of less fuel injected, the gain in power is accompanied by a drop in thermal efficiency from 32.6 per cent to 21.5 per cent.

The injection-rate curves, shown in Figure 16, are quite similar with the exception that the curve for full loads extends over a longer injection period. Other differences in the curves may be attributed to the use of different nozzles in the injection valve for the two tests, nozzle No. D-3 having been used for the part-load run and No. D-2 having been used for the full-load run.

A comparison of the maximum-power cycles, using single and double-stem injection valves, may be obtained from the cards in Figure 17. Identical pump displacement rates and similar nozzles were used in the two cases although the longer time of injection through the 0.008-inch orifices with the double-stem valve resulted in different fuel distribution. The characteristic necessary lateness of ignition is evident on the single-stem injection valve record, with a slight expansion loss before the ignition point. The expansion curve after the peak-explosion pressure has been reached, however, indicates less late burning than with the double-stem valve. The higher efficiency of burning with the single-stem valve is shown in the power output. The single-stem valve gives an i.m.e.p. of 129 pounds per square inch, whereas the double-stem valve gives a maximum of 114 pounds per square inch. The injection-rate curves for the two valves are shown in Figure 18 for comparison. The characteristic pump at the start of injection and the longer injection period required by the double-stem valve are clearly shown. *dump -*

The effect of rate-of-pump displacement on the shape of the indicator card may be seen by a comparison of cards of Figure 19. These cards show cylinder pressures with the double-stem valve at pump-start settings of 225, 270, 300, 360 and 400. The three lower cards have a 1,000-pound per square inch difference in stem-opening pressures, but for the two higher rates-of-pump displacement shown, it was necessary for the difference to be increased to 2,000 pounds per square inch. Even then, the higher rates

of injection when using the 400 start setting resulted in simultaneous opening of the primary and main stems.

A consideration of all the cards shown reveals a strikingly constant period of delay between the point of first introduction of the fuel and start-of-pressure rise due to combustion. The average time interval for this ignition lag for eight cards from which it may be read is $29.5 \pm 1.5^\circ$, or 0.00327 second, 5.5° longer than the lag assumed in computing the theoretical indicator card. An exception to this experimental average is found in the card of Figure 14 for the double-stem valve. Bird's experiments showed that for the injection of fuel into air of constant density and temperature, the ignition lag is much greater for high air-fuel ratios than for richer mixtures (see reference 13), which may partially explain the greater lag found at the low-injection rate under engine power conditions. The earlier start of injection which places the fuel in contact with the air during the early part of the compression stroke when the air temperature is comparatively low, doubtless affects the time required to heat the fuel to the ignition temperature.

Conclusions

From this investigation the following conclusions may be drawn:

1. Satisfactory mechanical operation may be obtained from an automatic-injection valve employing two concentric individually spring-loaded lapped stems.
2. Flat stem seats are quite satisfactory in preventing dribble and enable the use of smaller lifts than the conical seat. Wear due to erosion, however, is greater than with a conical seat.
3. With the injection system used in this investigation and with a 2,000-pound per square inch difference between opening pressures of the two sets of orifices, two stages of injection may be obtained when the fuel is displaced by the pump at a rate not in excess of 10.3 cubic inches per second. At faster rates of displacement both stems lift simultaneously.

4. The use of the double-stem valve in an engine under power permitted control of the shape of the indicator card within limits. Engine performance suffered, however, due to the late burning and poorer distribution incurred through this process.

5. When ignition is initiated before completion of injection, the rate-of-pressure rise in the engine cylinder is affected by the rate-of-fuel injection; hence, the rate of injection has a definite influence on the rate of combustion.

6. The control of injection rates permitted by this double-stem injection valve is not sufficient to effect the desired rates of combustion under the conditions of these tests.

Langley Memorial Aeronautical Laboratory,
National Advisory Committee for Aeronautics,
Langley Field, Va., October 5, 1931.

References

1. Rothrock, A. M.: Combustion in a High-Speed Compression Ignition Engine. T.R. No. 401, N.A.C.A., 1931
2. Butler, E. K.: Internal Combustion Engine Design and Practice. Charles Griffin and Co., Ltd., London, 1920, pp. 126, 127.
3. Butler W. H.: Fuels for Automotive Diesel Engines. Paper read at meeting of Society of Automotive Engineers, at White Sulphur Springs, W. Va., June 14-19, 1931.
4. Bird, A. L.: Oil Engines. Meuthen and Co., Ltd., London, 1923, pp. 128, 129.
5. Spanogle, J. A., and Foster, H. H.: Performance of a High-Speed Compression-Ignition Engine Using Multiple Orifice Fuel Injection Nozzles. T.N. No. 344, N.A.C.A., 1930.
6. Hicks, C. W., and Moore, C. S.: The Determination of Several Spray Characteristics of a High-Speed Oil Engine Injection System with an Oscilloscope. T.N. No. 298, N.A.C.A., 1928.
7. Beardsley, E. G.: The N.A.C.A. Photographic Apparatus for Studying Fuel Sprays from Oil Engine Injection Valves and Test Results from Several Researches. T.R. No. 274, N.A.C.A., 1927.
8. Spanogle, J. A., and Foster, H. H.: Basic Requirements of Fuel-Injection Nozzles for Quiescent Combustion Chambers, T.N. No. 382, N.A.C.A., 1931.
9. Collins, J. H., jr.: Alterations and Tests of the Farnboro Engine Indicator. T.N. No. 348, N.A.C.A., 1930.
10. Gerrish, H. C., and Voss, F.: Investigation of the Discharge Rate of a Fuel-Injection System. T.N. No. 373, N.A.C.A., 1931.
11. Taub, Alex: Combustion Chamber Progress Correlated. S.A.E. Journal, October, 1930.

12. Hicks, C. W.: The Measurement of Maximum Cylinder Pressures. T.R. No. 294, N.A.C.A., 1928.
13. Bird, A. L.: Some Characteristics of Nozzles and Sprays for Oil Engines. Transactions, Second World Power Conference, V.D.I. - Verlag G.M.B.H., Berlin, 1930, p. 267.

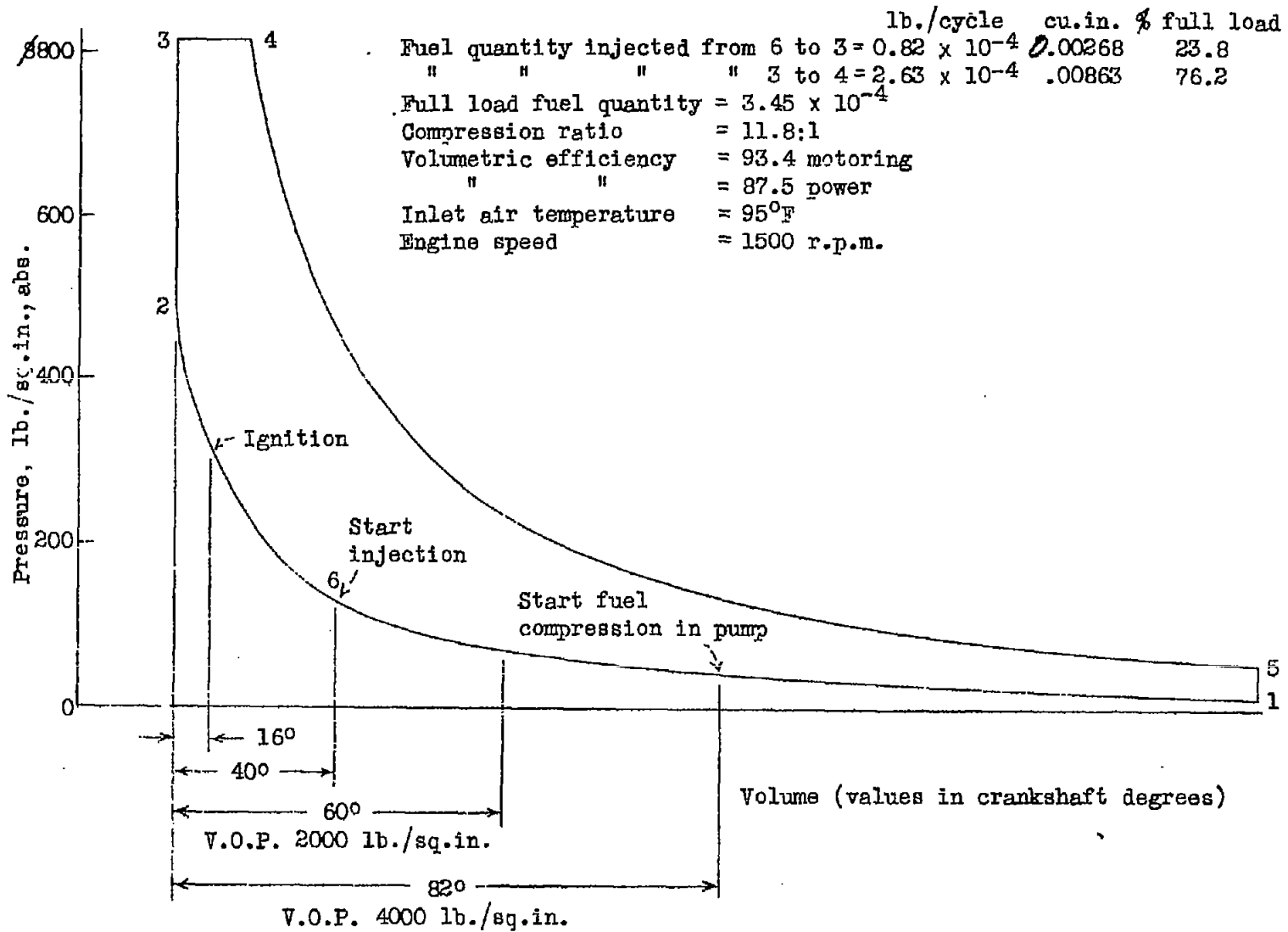

Fig. 1 Theoretical indicator card

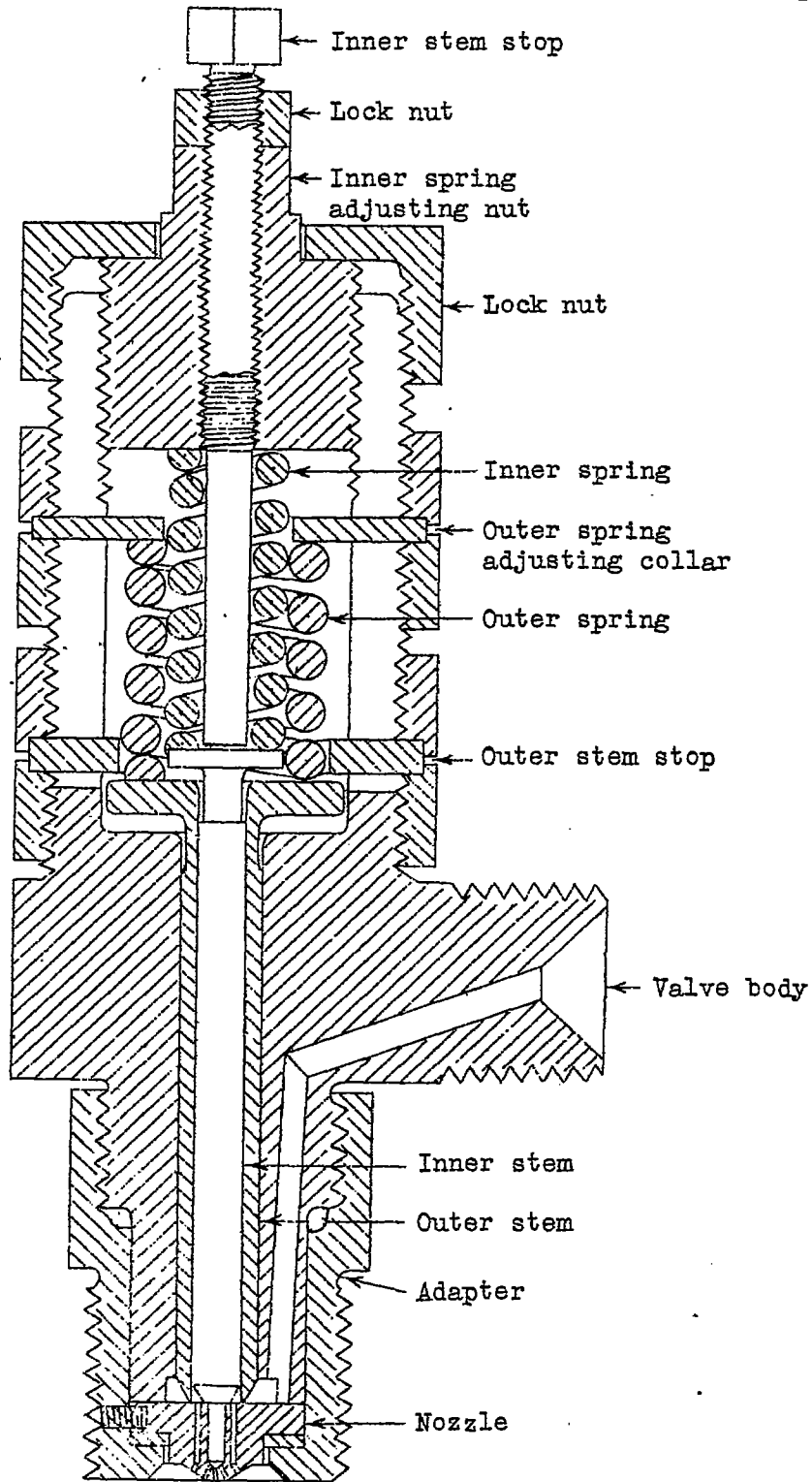

Fig. 2 Double-stem valve

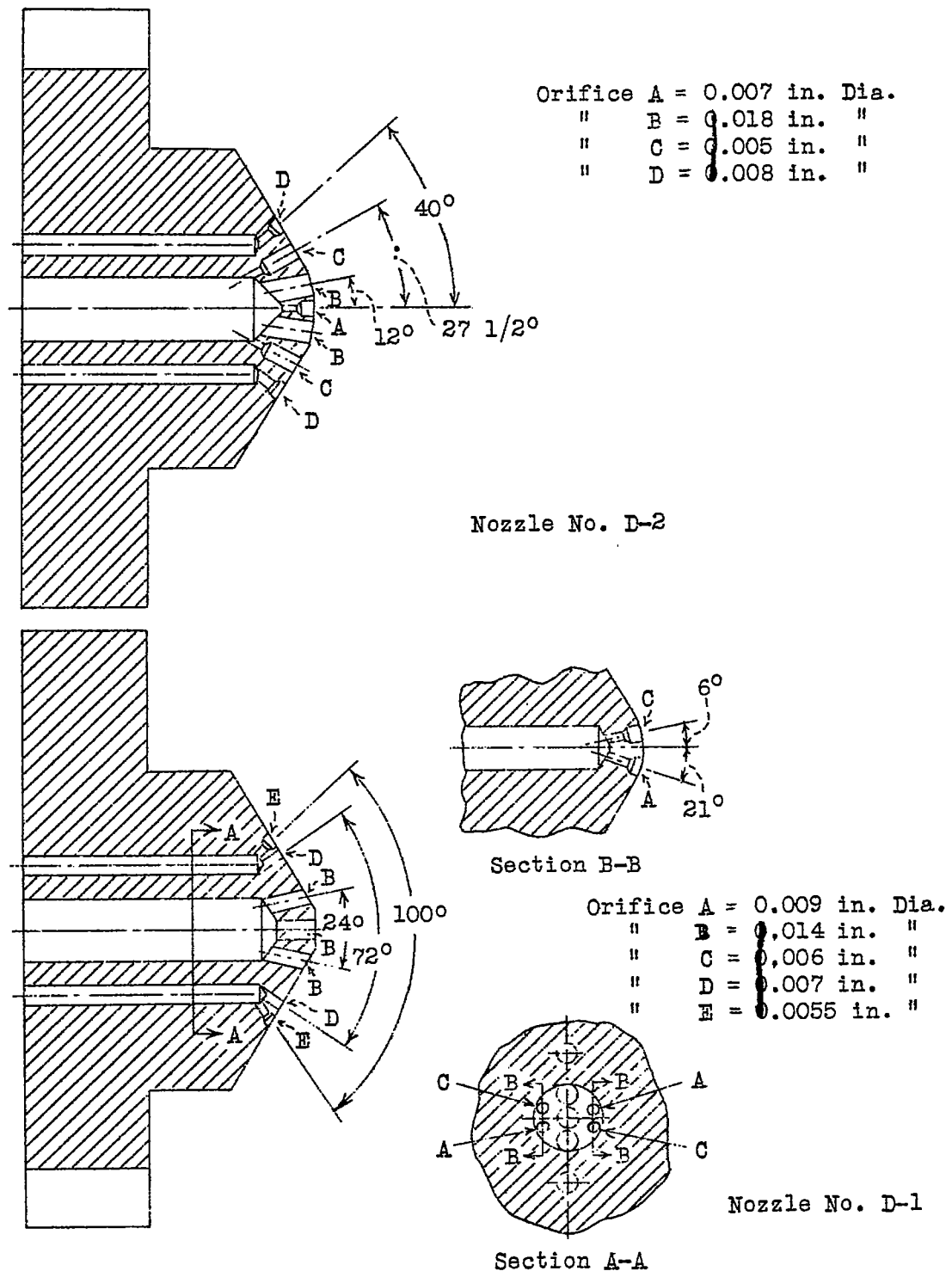
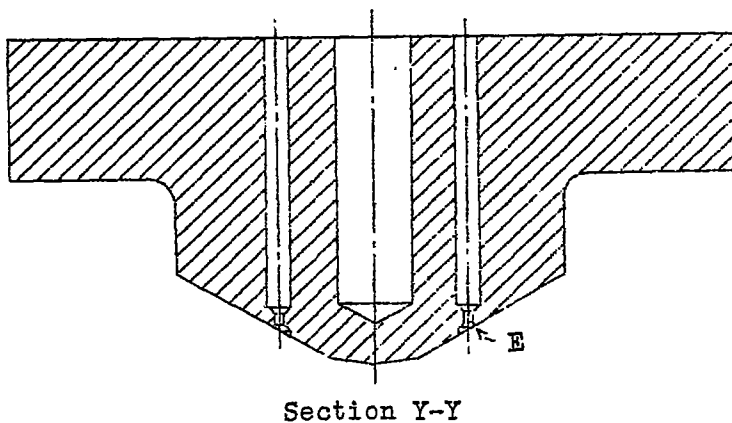
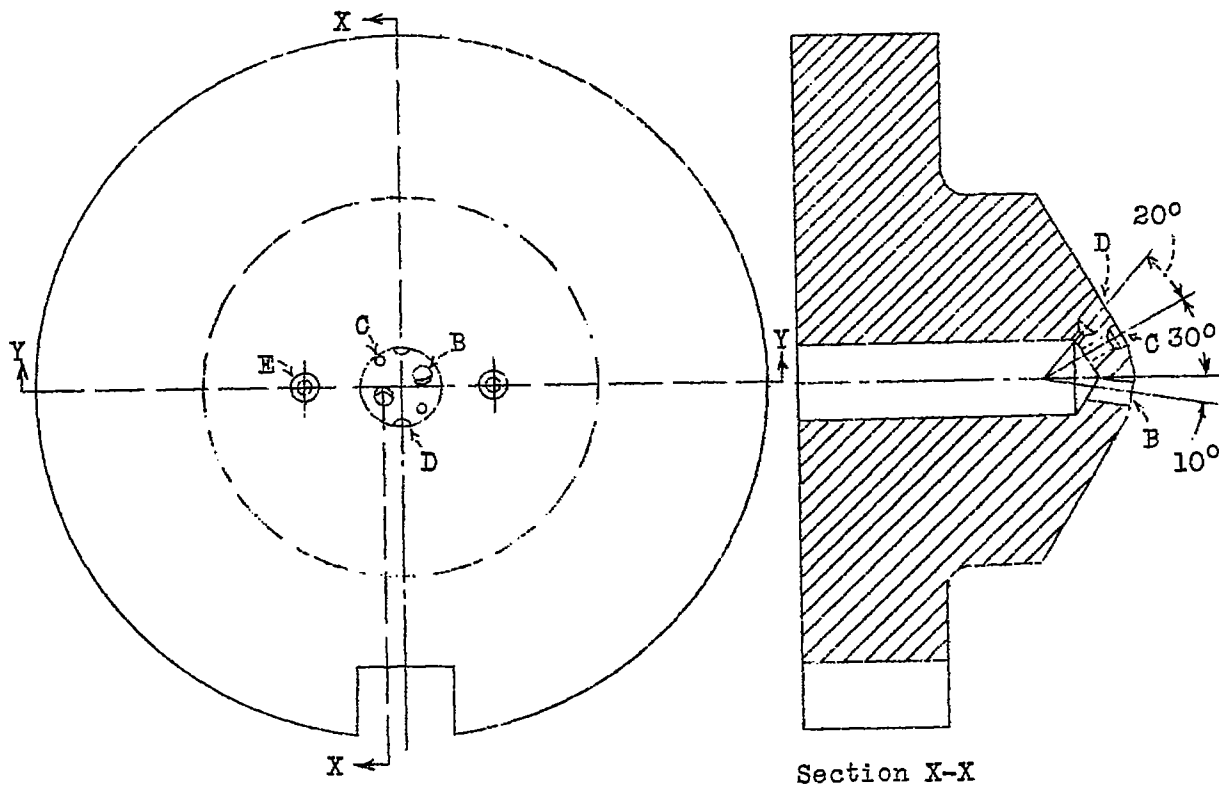
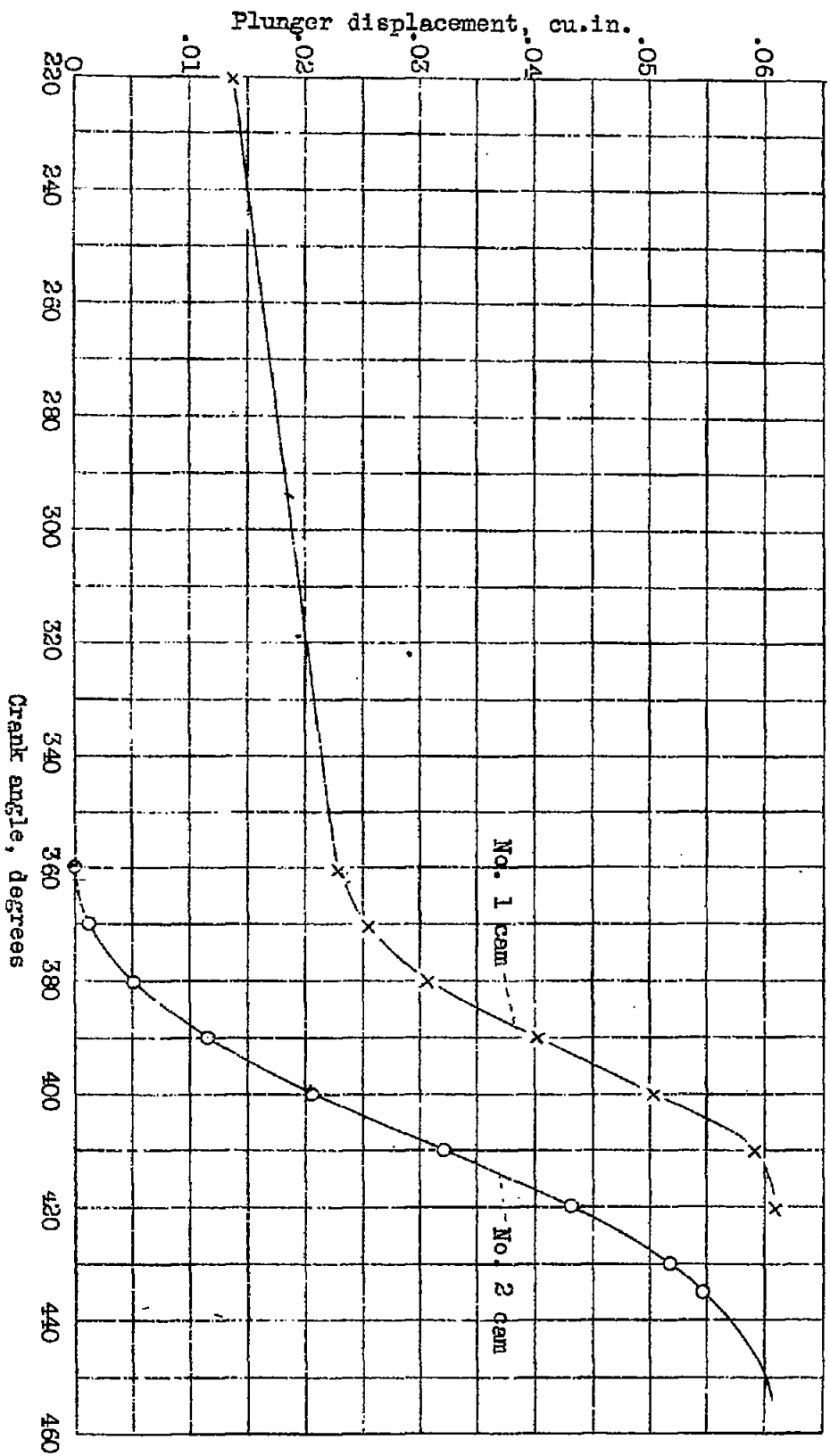

Fig. 3 Nozzles No. D-1 and D-2



Orifice B = 0.018 in. Dia.
 " C = 0.010 in. "
 " D = 0.006 in. "
 " E = 0.005 in. "

Fig. 4 Nozzle No. D-3



N.A.C.A. Technical Note No. 402

Fig. 5

Fig. 5 Fuel pump displacement

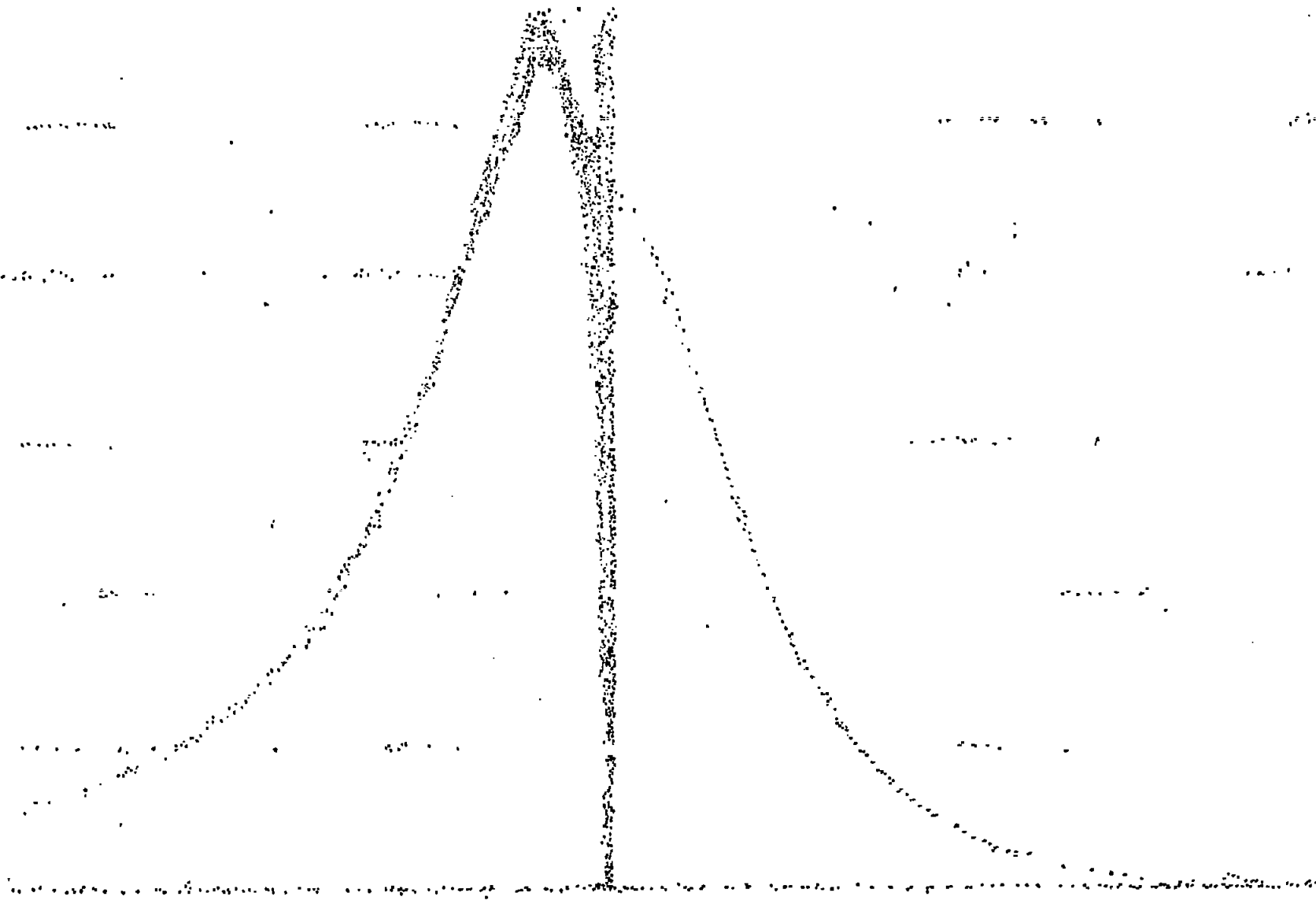

Fig. 6

Fig. 6 Original pressure time card

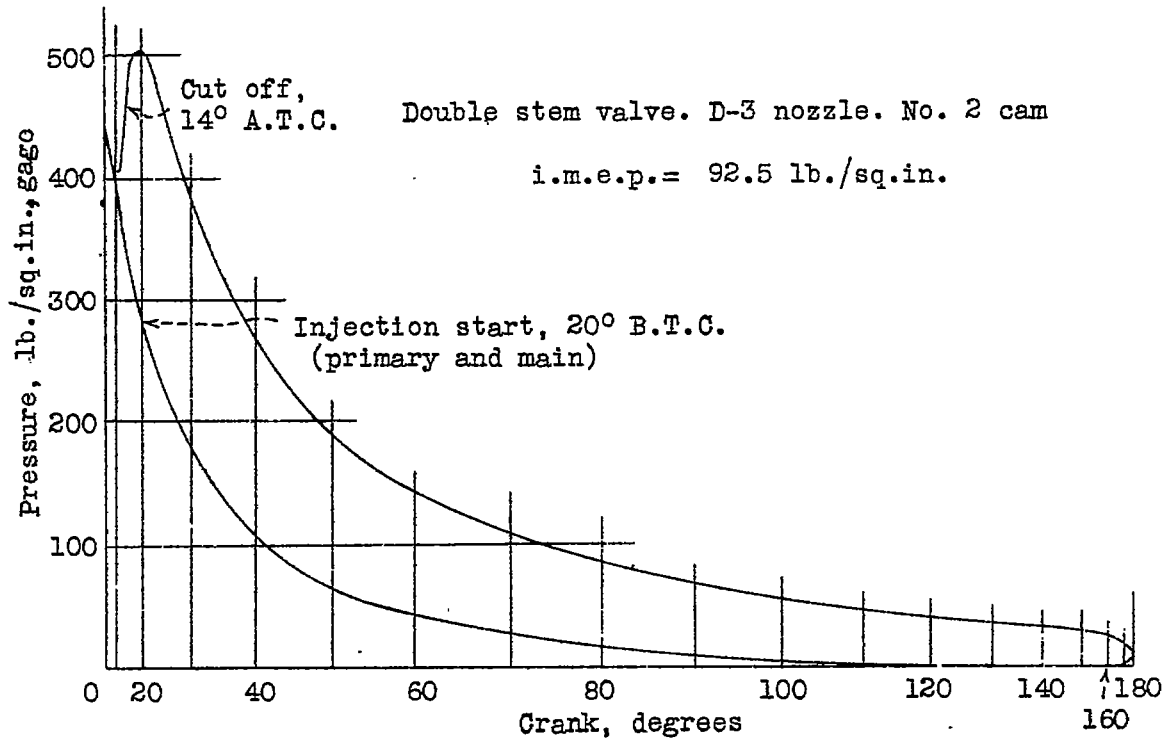
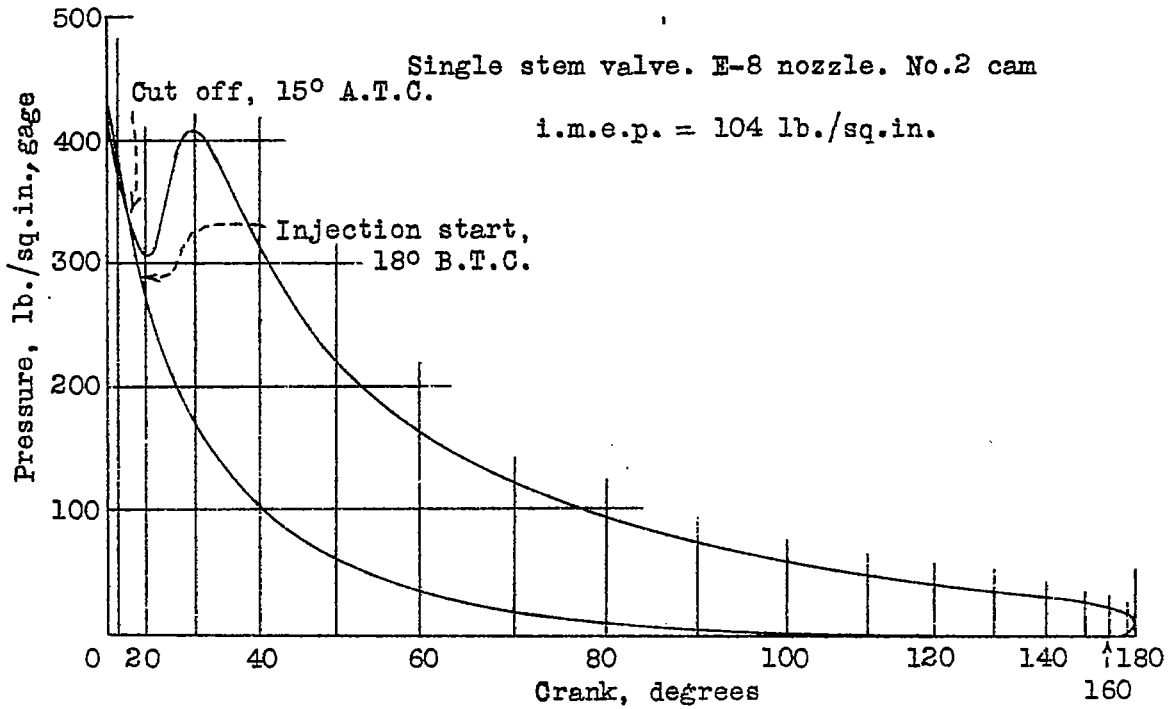

Fig. 7 Effect of double injection on P-V cards at 400 start setting

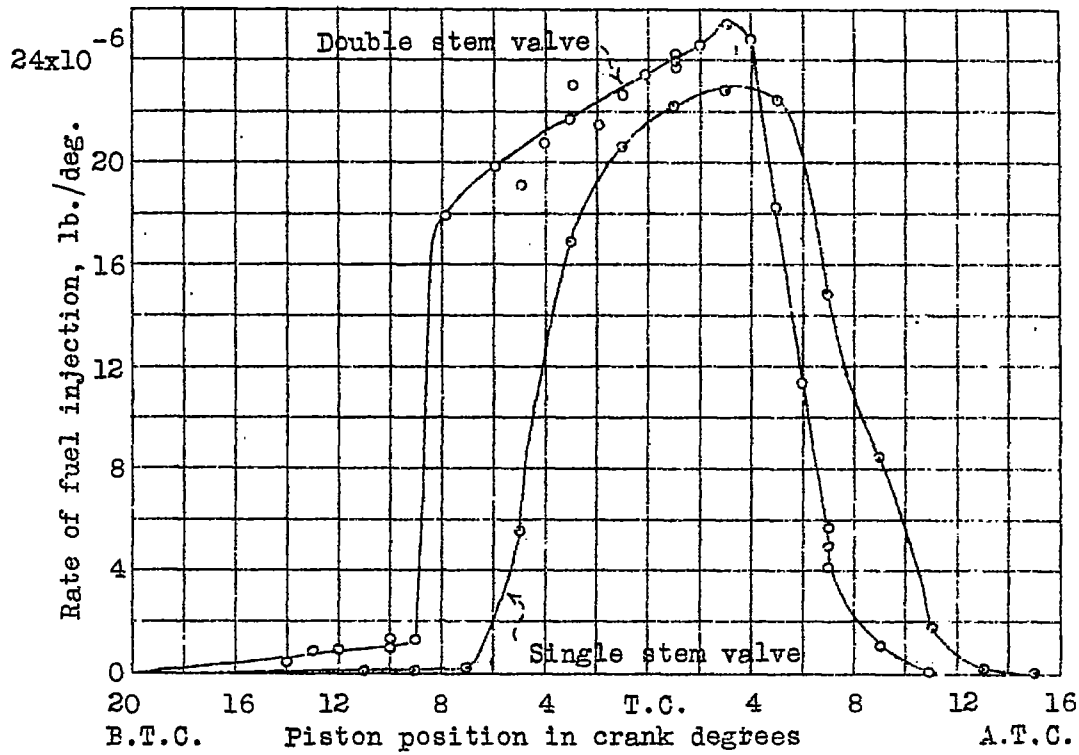

Fig. 8 Fuel injection rate curves for cards of Fig. 7

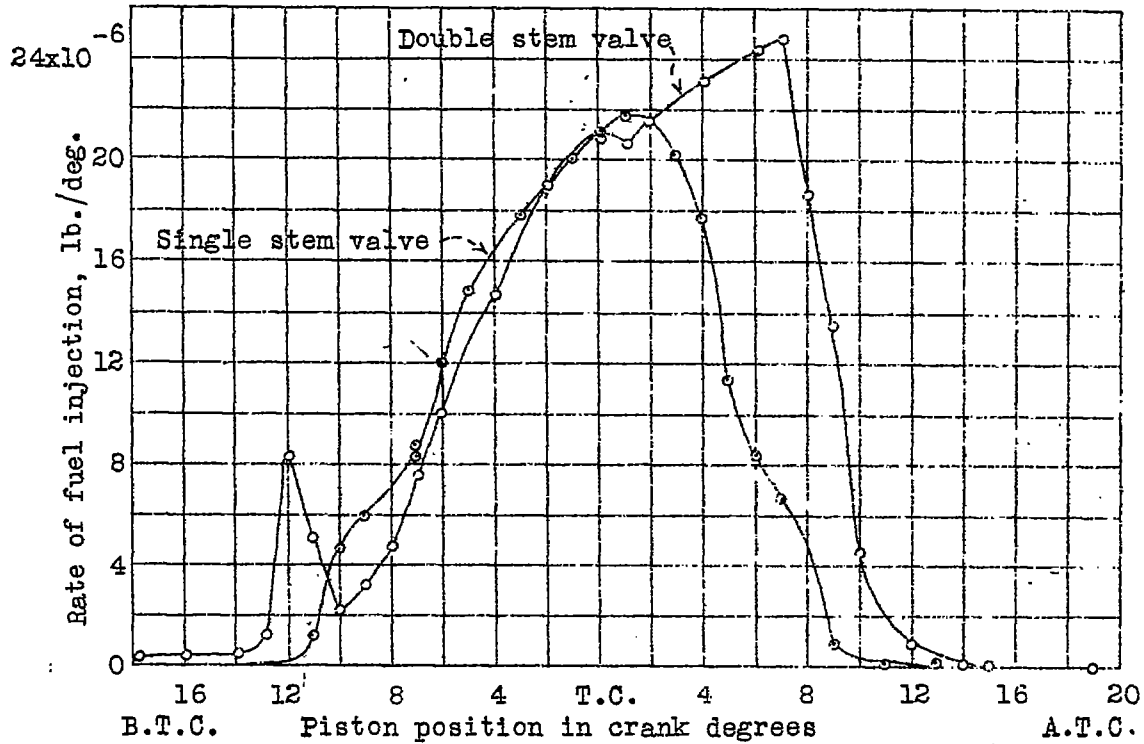

Fig. 10 Fuel injection rate curves for cards of Fig. 9

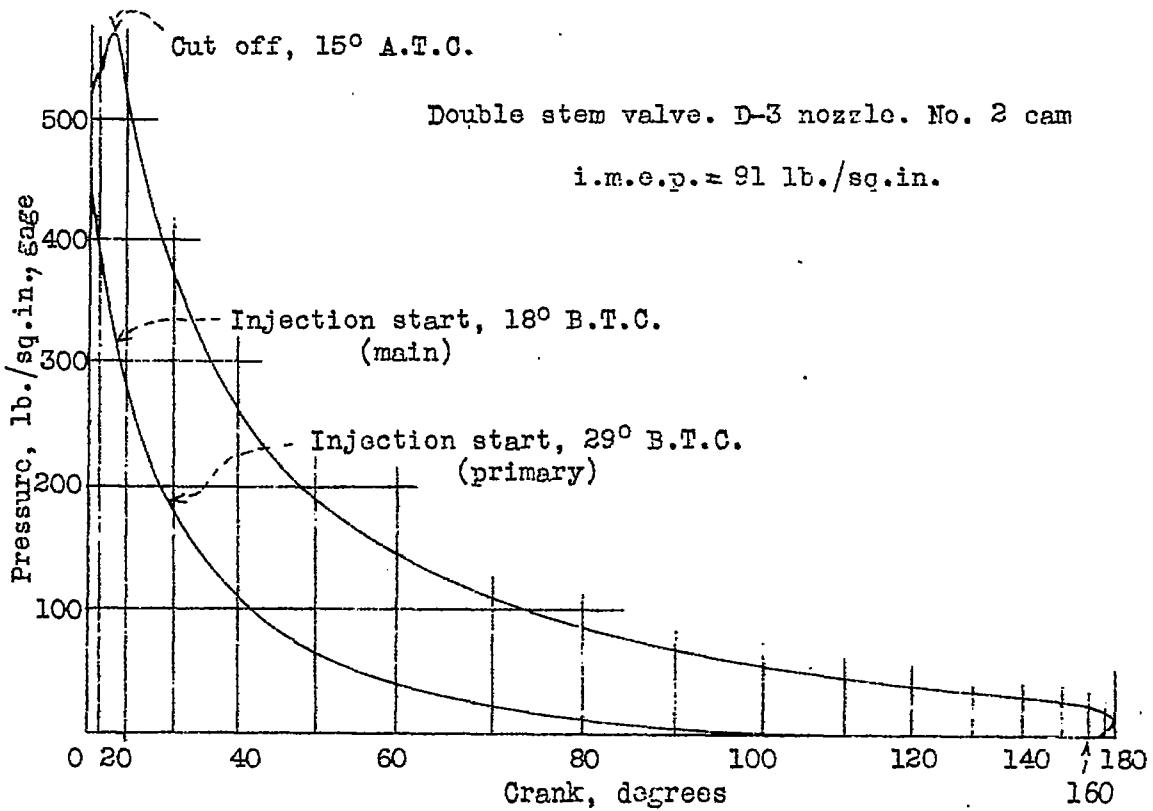
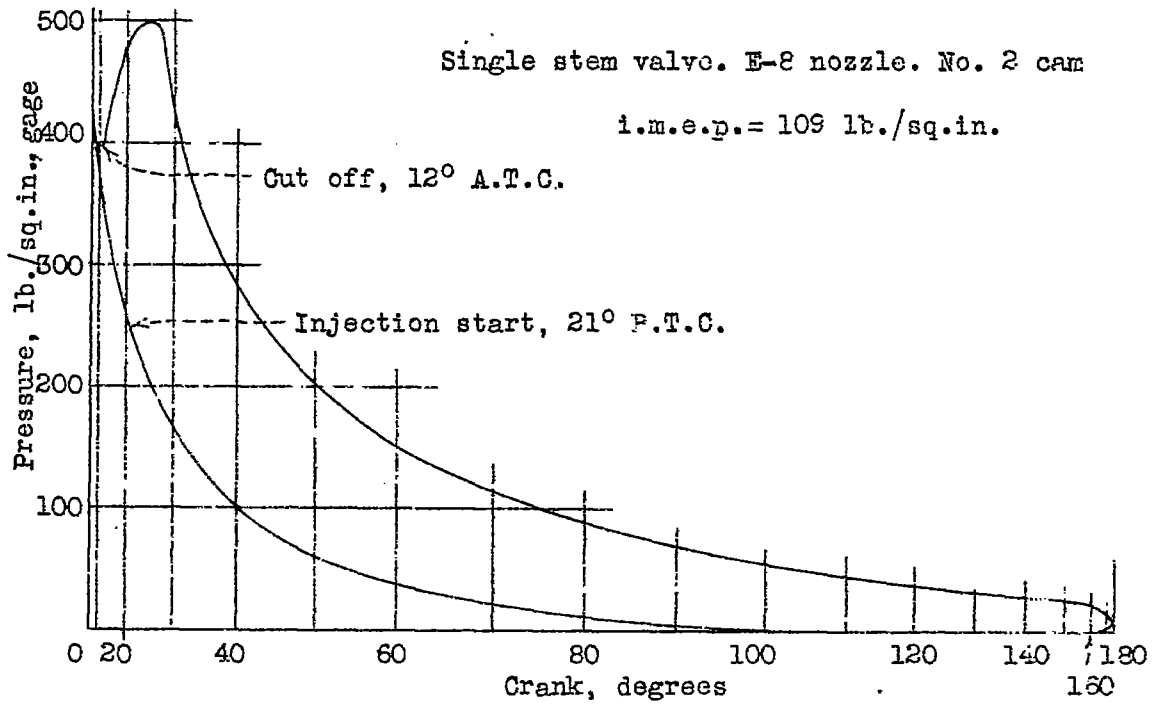

Fig. 9 Effect of double injection on P-V cards at 360 start setting

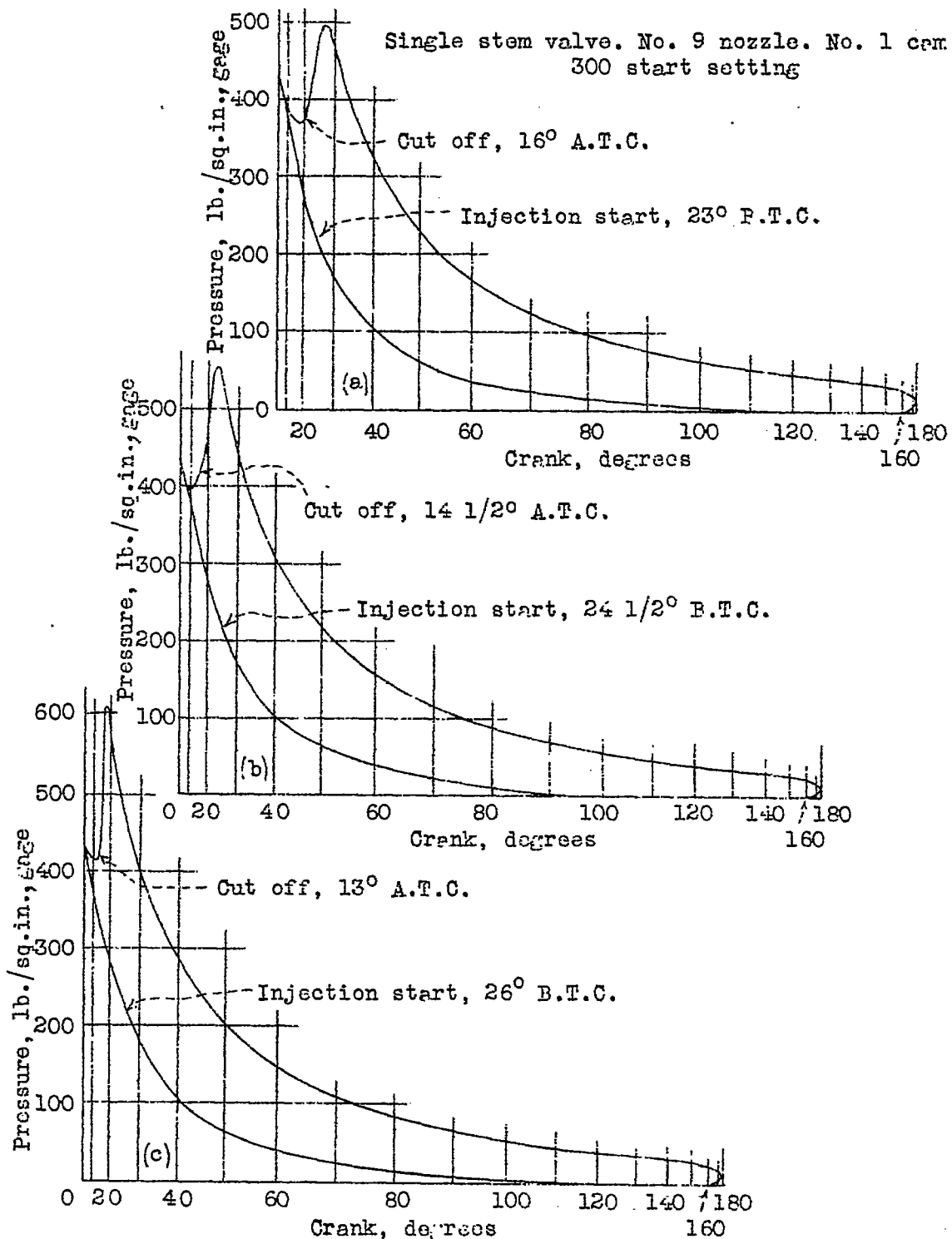

Fig. 11 Effect on P-V cards of advancing the time of injection
i.m.e.p. = 106 lb./sq.in.

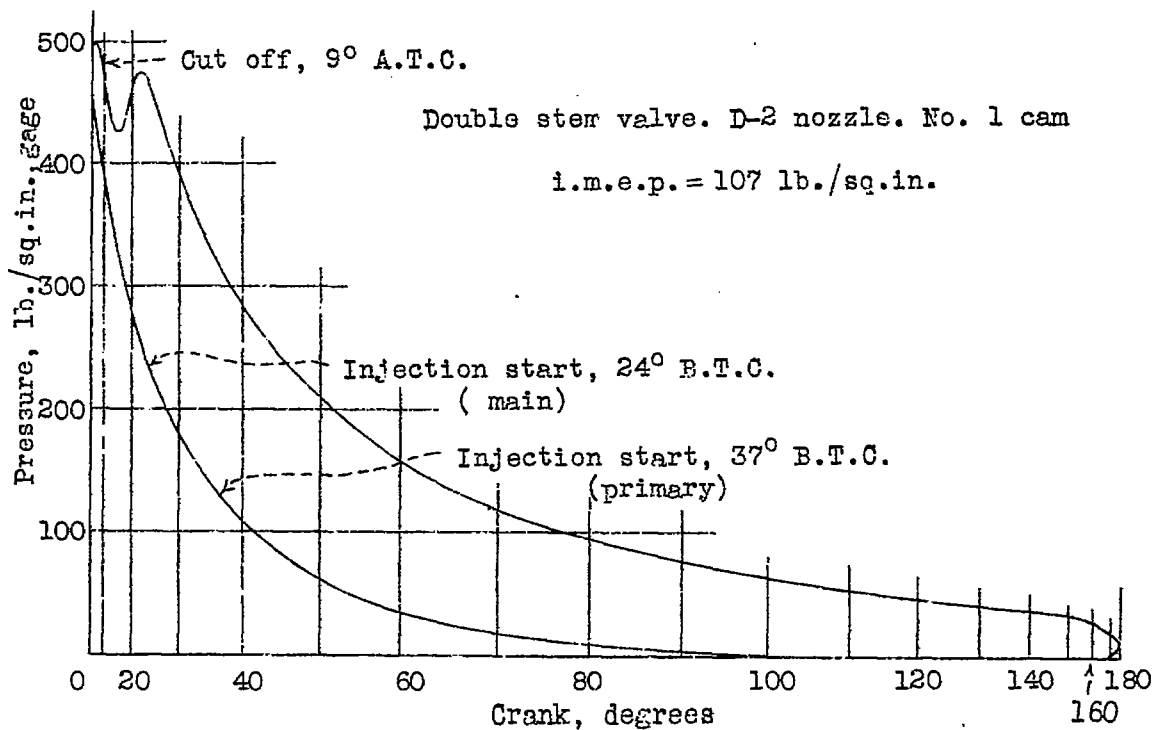
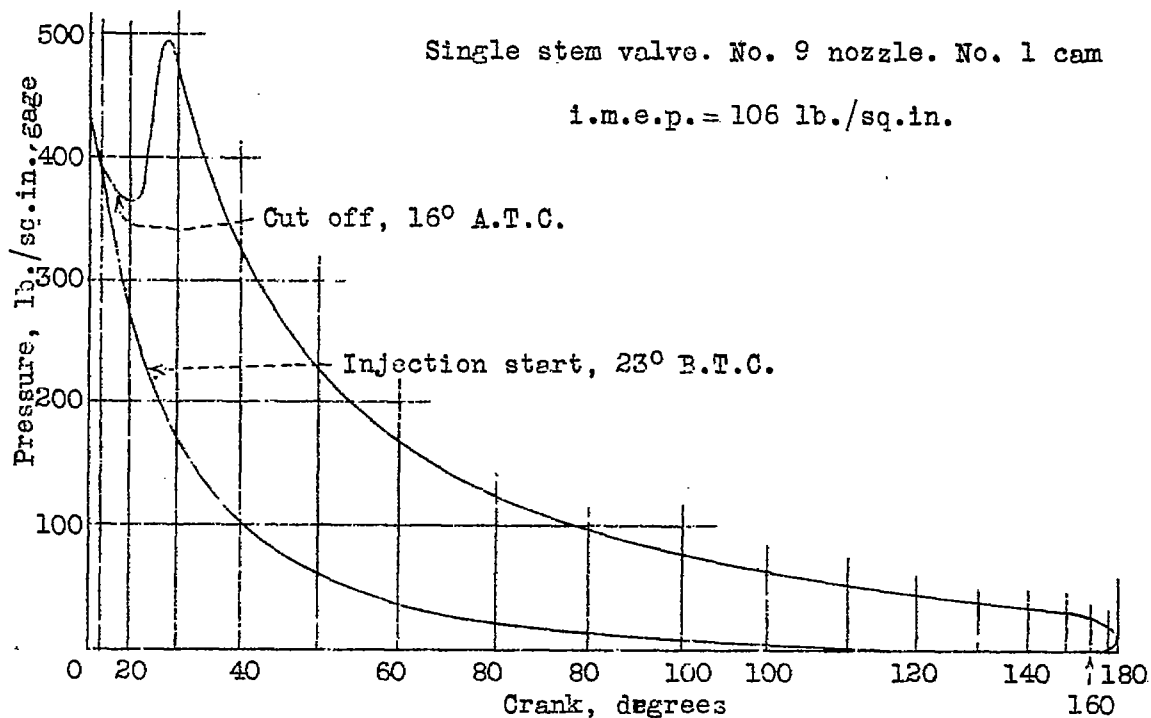

Fig. 12 Effect of double injection on the P-V card at 300 start setting

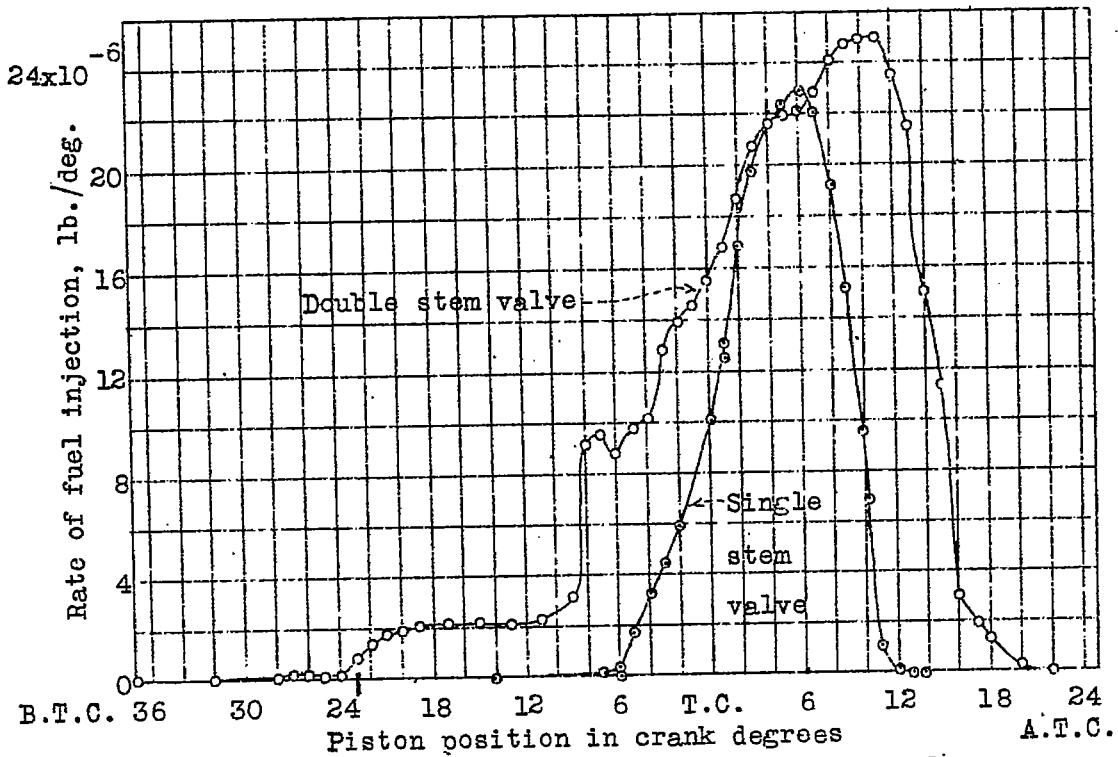

Fig. 13 Fuel injection rate curves for cards of Fig. 12

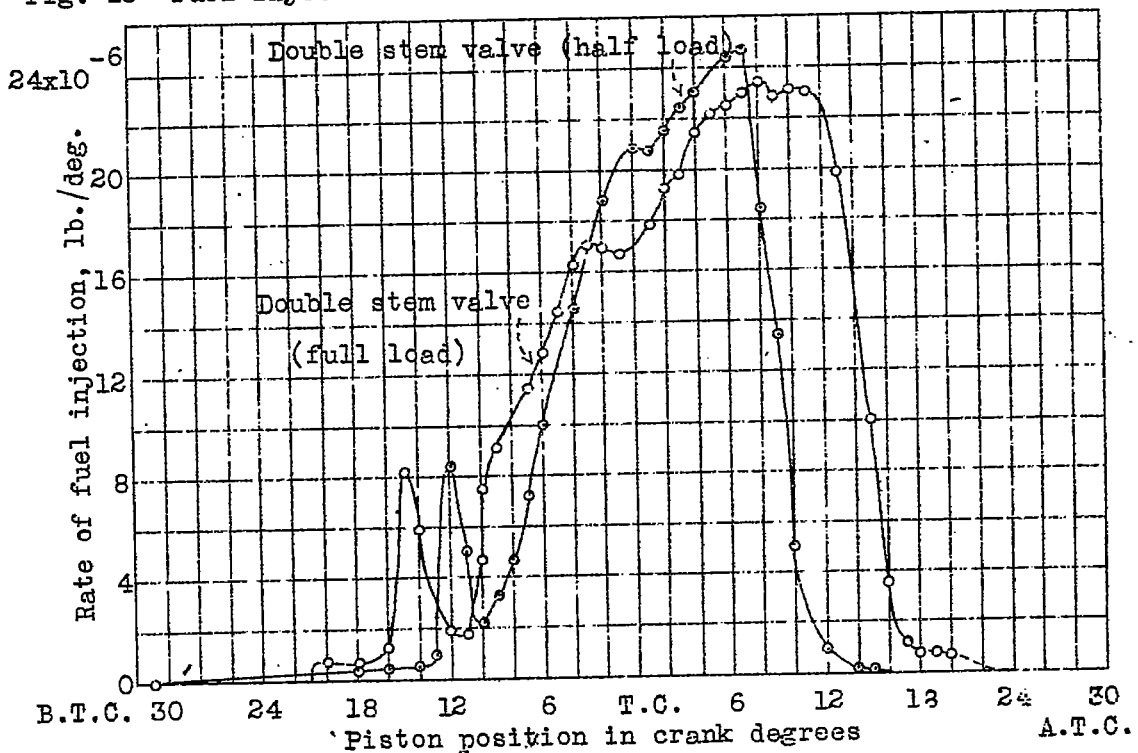

Fig. 16 Fuel injection rate curves for cards of Fig. 15

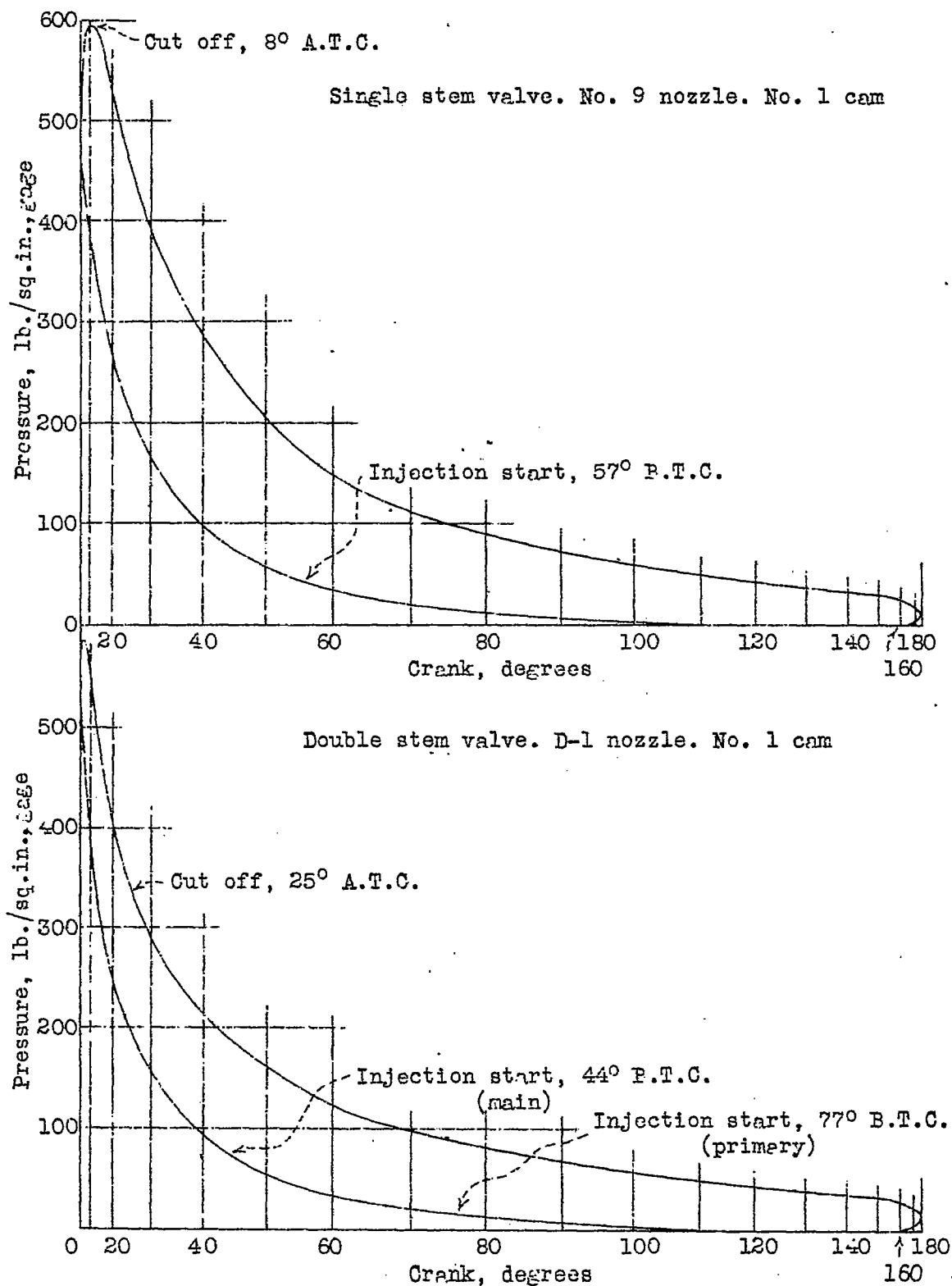

Fig. 14 Effect of double injection on P-v cards at 225 start setting

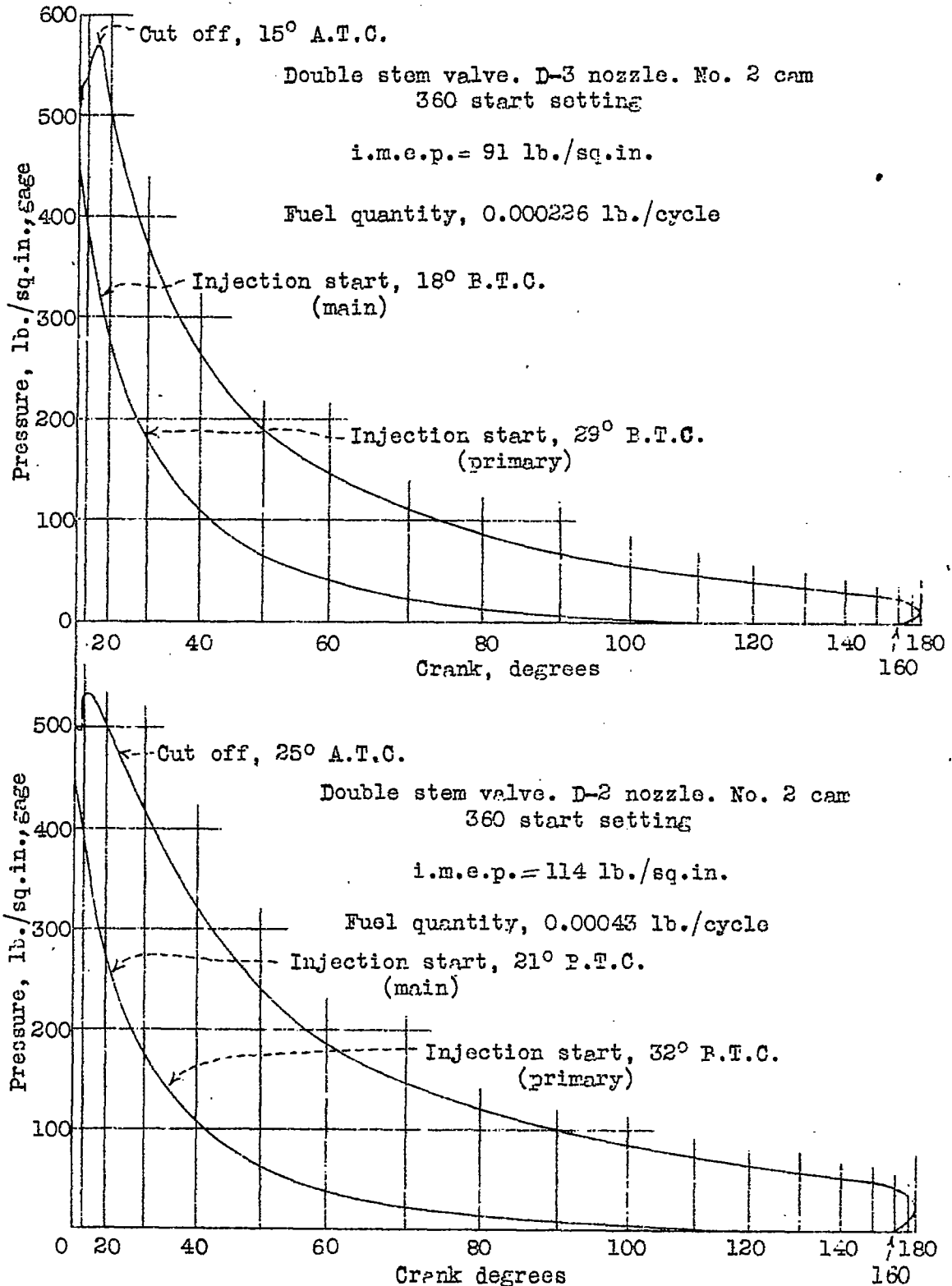

Fig. 15 Effect of load on P-V cards with double injection

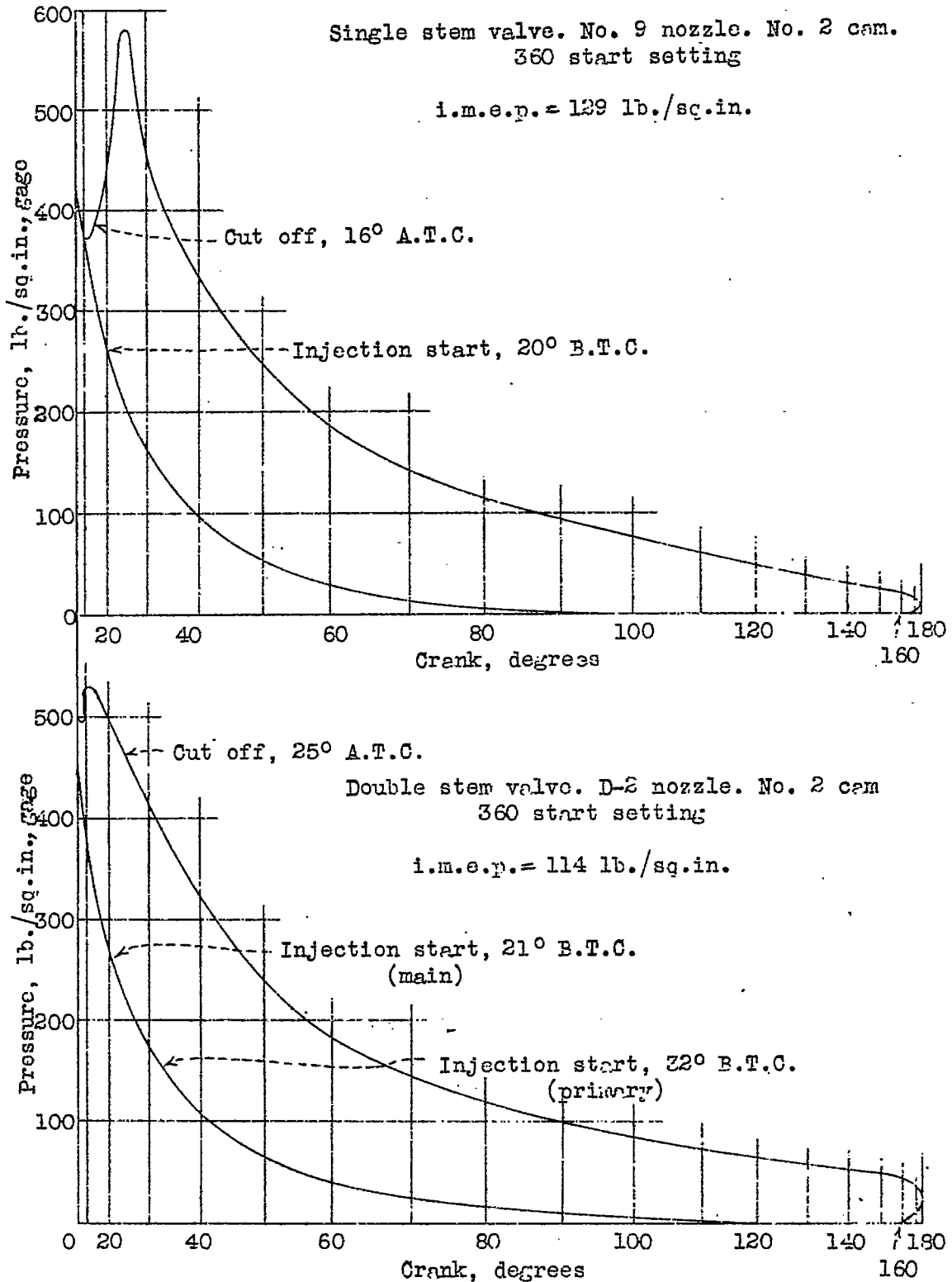

Fig. 17 Effect of double injection on P-V card at maximum engine power

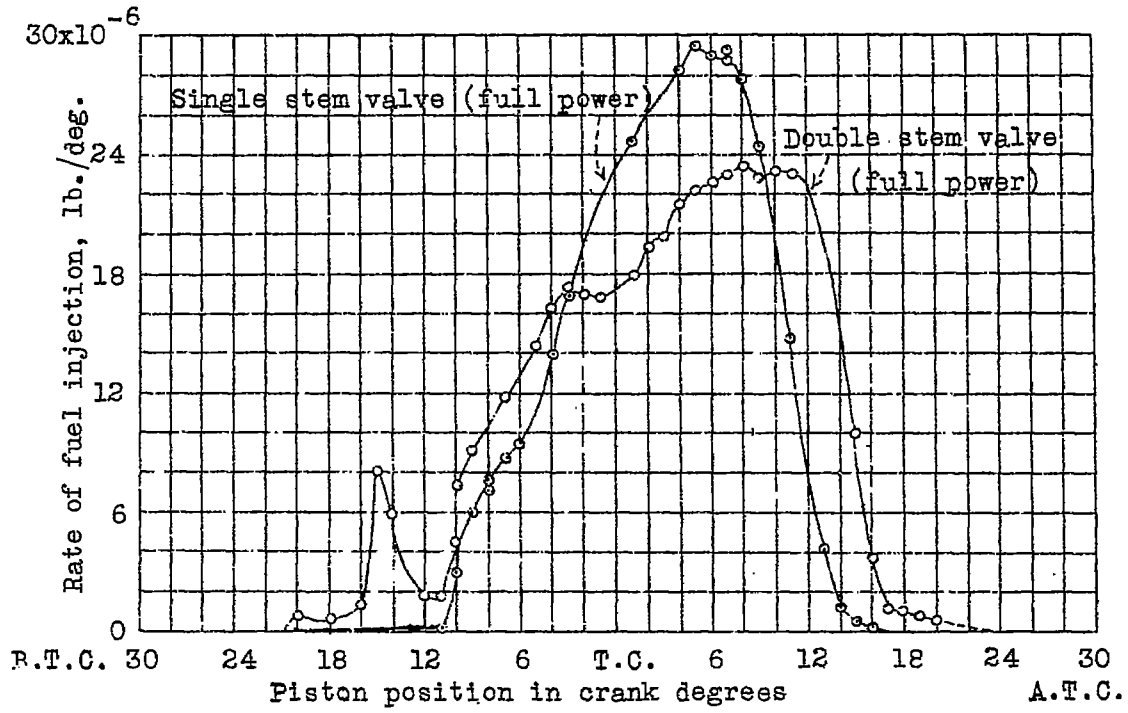

Fig. 18 Fuel injection rate curves for cards of Fig. 17

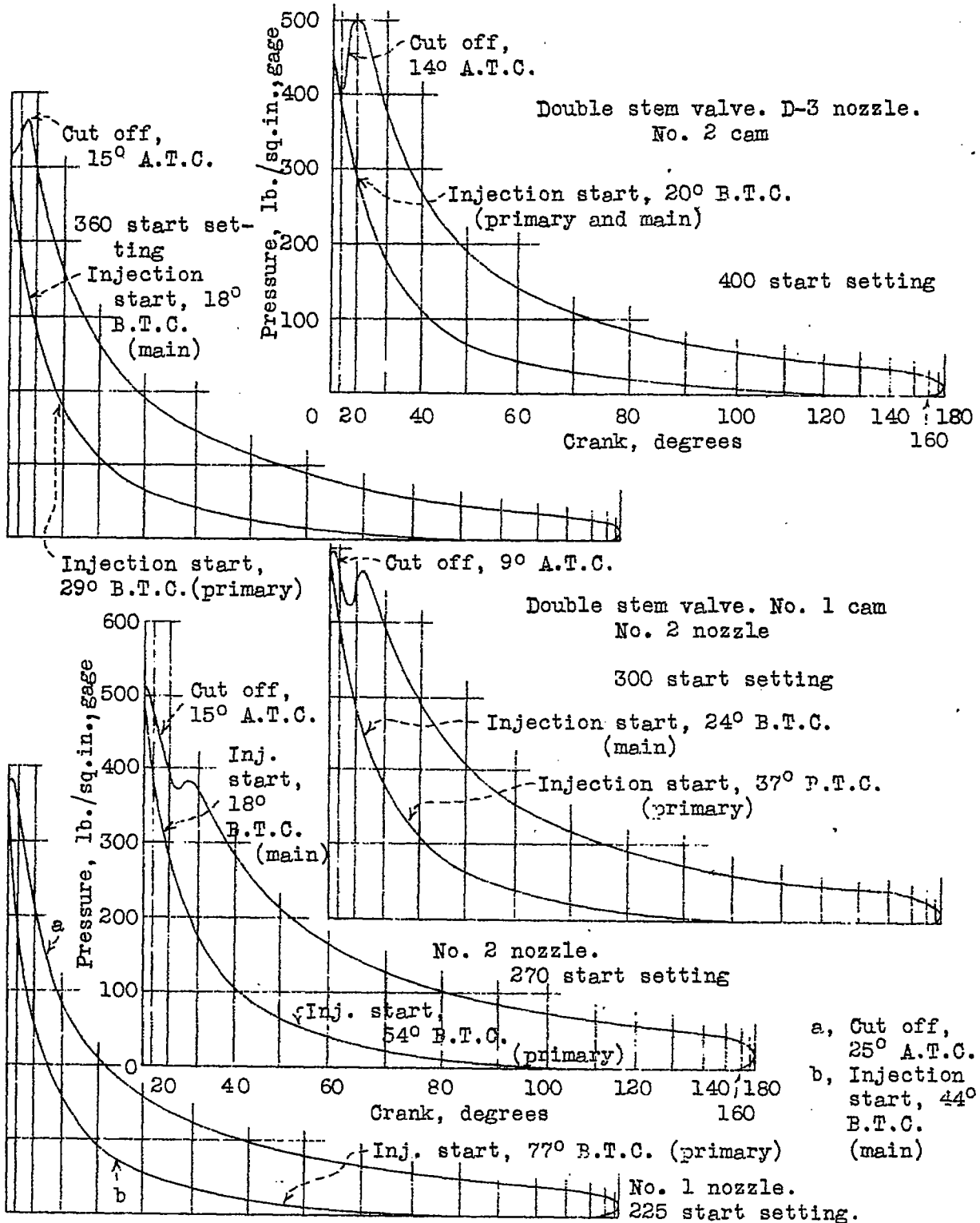

Fig. 19 Effect of rate of pump displacement on P-V cards with double injection