

3

~~N 62 52447~~

447

TECHNICAL NOTES

NATIONAL ADVISORY COMMITTEE FOR AERONAUTICS

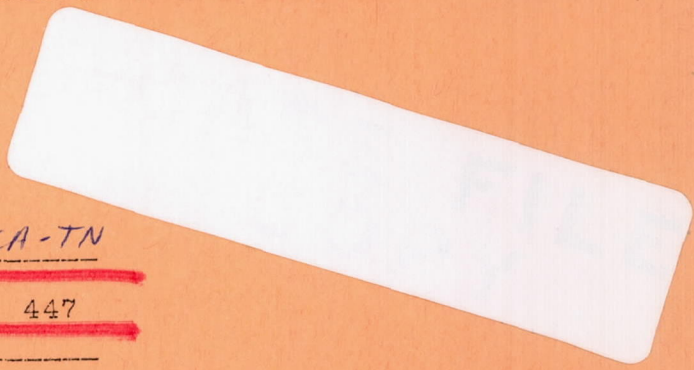

files as: NACA-TN
No. 447

THE EFFECT ON LIFT, DRAG, AND SPINNING CHARACTERISTICS
OF SHARP LEADING EDGES ON AIRPLANE WINGS

By Fred E. Weick and Nathan F. Scudder
Langley Memorial Aeronautical Laboratory

Reproduced by
**NATIONAL TECHNICAL
INFORMATION SERVICE**
U S Department of Commerce
Springfield VA 22151

Washington
February, 1933

26

E R R A T A

NATIONAL ADVISORY COMMITTEE FOR AERONAUTICS

TECHNICAL NOTE NO. 447

THE EFFECT ON LIFT, DRAG, AND SPINNING CHARACTERISTICS
OF SHARP LEADING EDGES ON AIRPLANE WINGS

Page 13, Table I: Under "Momenta ellipsoid constants" insert "A" in the first column, "B" in the second column, and "C" in the third column, immediately above and in the same box as "slug ft.²."

NATIONAL ADVISORY COMMITTEE FOR AERONAUTICS

TECHNICAL NOTE NO. 447

THE EFFECT ON LIFT, DRAG, AND SPINNING CHARACTERISTICS
OF SHARP LEADING EDGES ON AIRPLANE WINGS

By Fred E. Weick and Nathan F. Scudder

SUMMARY

An investigation with special reference to autorotation and spinning was conducted in two wind tunnels and in flight to find the aerodynamic effects of adding a sharp leading edge to a wing section.

In the wind-tunnel investigation free-autorotation tests, forced-rotation tests, and lift and drag tests were made on modified Clark Y airfoils in the 7 by 10 foot wind tunnel, and check tests on the lift and drag characteristics at several values of the Reynolds Number were made in the variable-density wind tunnel. Two different forms of sharp leading edge were tried. Both reduced the maximum unstable rolling moment tending to start autorotation, but neither had a substantial effect on the final rate of free autorotation.

In the spin tests in flight, which were made on a small training biplane, the addition of sharp leading edges produced favorable effects, causing a decrease in the angle of attack and rate of rotation and making the controls more effective. The flight and wind-tunnel tests agreed in showing that the use of the sharp leading edges is accompanied by a substantial reduction in the maximum lift coefficient.

INTRODUCTION

Two commercial airplane manufacturing organizations have recently reported the elimination of undesirable spinning characteristics of certain of their airplanes by adding sharp leading edges to the wings. Since these reports, tests have been made in the variable-density wind tunnel on

the lift and drag characteristics of a Göttingen 398 airfoil with two different sharp leading edges added. (Reference 1.) With either of the sharp leading edges the maximum lift coefficient was reduced to the point where there was little negative slope to the curve of lift coefficient against angle of attack beyond the stall, indicating that the tendency to autorotate had been considerably reduced.

The investigation has been extended by finding the effect of a sharp leading edge on the autorotational characteristics of an airfoil in a wind tunnel and also on the spinning characteristics of an airplane in flight. The wind-tunnel experiments include both free-autorotation tests and forced-rotation tests, as well as lift and drag tests in the 7 by 10 foot atmospheric wind tunnel. The basic airfoil used in these tests was the Clark Y and two different sharp leading edges essentially similar to those used on the Göttingen 398 airfoil in the variable-density wind tunnel tests were added. The tests of the modified Clark Y airfoil in the 7 by 10 foot tunnel, however, showed greater negative slope to the lift curve at angles of attack just above the stall than would have been expected from the variable-density tunnel tests on the modified Göttingen 398. In order to obtain a direct check on this point additional tests were made in the variable-density tunnel on the modified Clark Y section having the sharper of the two sharp leading edges tested in the 7 by 10 foot tunnel.

In the flight tests, measurements were made to determine the effect on the steady spin and on the performance in normal flight of the addition of a sharp leading edge, corresponding to the sharper of the two used in the wind-tunnel tests, to the wings of a small biplane. The effect of the sharp nose on the performance of the airplane was obtained by simple measurements of the minimum speed in gliding flight and of the maximum speed in level flight.

The results of all the above-mentioned tests are given in this paper, the material being divided for convenience into two parts, Part I dealing with the wind-tunnel tests and Part II dealing with the flight tests.

PART I - WIND-TUNNEL TESTS SHOWING EFFECT ON
LIFT, DRAG, AND AUTOROTATION

By Fred E. Weick

Apparatus and Methods

Tests in the 7 by 10 foot tunnel.- The sharp-nosed models were formed by adding Plasticine to the leading edge of a 10 by 60 inch laminated mahogany Clark Y airfoil, as shown in Figure 1. With the first modification, the Clark Y-A, the sharp leading edge was 1 per cent of the wing chord ahead of the original leading edge, and with the second modification, the Clark Y-B, this projection was 2 per cent.

The 7 by 10 foot wind tunnel together with its balances and rotation gear is described in reference 2. For free-autorotation tests the model is mounted on a shaft parallel to the air flow and supported freely on ball bearings. The forced-rotation tests are made with the same shaft driven by an electric motor.

All the present tests were made at the same air speed (80 m.p.h.). The forced-rotation tests, which were made to show the tendency of the rotation to increase or to damp out, all were made at one rotational velocity corresponding to a value of the coefficient

$$\frac{p'b}{2V} = 0.05$$

where p' is the angular velocity about the wind axis, b is the span of the wing, and V is the air velocity. This value has been indicated by flight experiments to be the highest rolling velocity likely to be encountered in flight in gusty air while the pilot is attempting to hold a steady course.

Test in the variable-density tunnel.- The variable-density tunnel and the methods used in the airfoil tests are described in reference 3.

Results

Lift.- Values of the lift and drag coefficients for the different angles of attack are given for the original Clark Y airfoil and the two modifications in Figure 2, the coefficients for all the airfoils being based on the total area. Both modifications give maximum lift coefficients 13 per cent lower than the original Clark Y but their lift curves still have a definite negative slope just above the stall. The curves of the normal-force coefficient against angle of attack (fig. 3) also have decided negative slopes in the region just above the stall. This result indicates that under the conditions of the present test the sharp leading edges should reduce the autorotation tendencies somewhat but not to the extent indicated by the variable-density tunnel tests with the modified Göttingen 398, where the maximum lift coefficient was reduced 26 per cent and the negative slope of the normal-force coefficient curve was reduced to a relatively small value. For this reason the following check tests were made with a model of the Clark Y-B airfoil in the variable-density tunnel.

Check tests in variable-density tunnel.- A 5 by 30 inch aluminum alloy model was tested at the Reynolds Number of the 7 by 10 foot tunnel tests (609,000), and at Reynolds Numbers of 167,000 (1 atmosphere) and 3,120,000 (20 atmospheres). As shown on Figure 4, at a Reynolds Number of 609,000 the value of C_{Lmax} and the angle at which it occurred were approximately the same as in the 7 by 10 foot tunnel test, but the lift coefficient did not decrease as rapidly beyond the maximum.

It was thought that the leading edge of the variable-density tunnel model might have been appreciably sharper than that of the 7 by 10 foot tunnel model which was formed of Plasticine. The leading edge of the variable-density tunnel model was therefore rounded until the chord was shortened by 0.010 inch. The form of the point is shown by the magnified sketch on Figure 4. This model was then tested at 1 and at 20 atmospheres. The lift-curve peak was flattened at 20 atmospheres and sharpened at 1 atmosphere, but the shape beyond the stall was not altered appreciably. It is concluded that the discrepancy between the curves from the variable-density tunnel and 7 by 10 foot tunnel tests should be attributed to a difference in the nature of the air flow in the tunnels.

Drag.- The profile-drag coefficients are plotted against lift coefficient for both the 7 by 10 foot tunnel tests and the high Reynolds Number variable-density tunnel tests in Figure 5. The values are, of course, lower for the variable-density tunnel tests made at a large value of the Reynolds Number, but the results from both tunnels agree in showing a slightly lower minimum profile drag for the sharp leading-edge section than for the original Clark Y.

Forced rotation.- The results of the forced-rotation tests are given in terms of a coefficient of rolling moment due to rolling

$$C_{\lambda} = \frac{\text{rolling moment}}{q b S}$$

where q is the dynamic pressure, b is the span, and S is the area of the wing. Moments aiding rotation are considered positive. The values of C_{λ} plotted against angle of attack are given for both directions of rotation in Figure 6. The maximum values of C_{λ} indicating instability which were found with either of the sharp leading-edge airfoils are only about one-third that for the original Clark Y. The tendency to autorotate is therefore greatly reduced with either form of sharp leading edge, both being about the same in this respect. The angle of attack for initial instability is about the same for the original Clark Y and the Clark Y-A, but the Clark Y-B becomes unstable at a slightly lower angle of attack, as would be expected from an examination of the lift and normal-force curves.

Free autorotation.- The rate of autorotation is shown for each of the airfoils by the curves of $\frac{p' b}{2 v}$ against angle of attack in Figure 7. It will be noticed that even though the tendency to start to autorotate, as shown by Figure 6, is greatly reduced by the addition of either of the sharp leading edges, the final rate of free autorotation is about the same as that of the original Clark Y throughout most of the angle-of-attack range. The maximum rotational velocities are definitely lower with the sharp leading edges, but not by a great amount.

The Clark Y-B started to autorotate at an angle of attack 3° lower than either the original Clark Y or the Clark

Y-A, which is in approximate agreement with the indications given by both the forced rotation and the lift and drag tests.

Conclusions

1. Both the sharp leading edges tested reduced the maximum unstable rolling moment tending to start autorotation to about one-third the value for the original Clark Y airfoil, but neither had a substantial effect on the final rate of free autorotation.

2. Both the sharp leading edges reduced the maximum lift coefficient 13 per cent in the 7 by 10 foot tunnel tests. The high Reynolds Number test of the Clark Y-B in the variable-density tunnel showed a reduction of 29 per cent.

PART II - FLIGHT TESTS SHOWING EFFECT ON THE SPIN AND PERFORMANCE OF THE XN2Y-1 AIRPLANE

By Nathan F. Scudder

Apparatus and Method

The airplane with which these tests were made was a small Naval training biplane powered with a Warner engine. The dimensions and arrangement of the airplane are given in the 3-view drawing of Figure 8. The basic airfoil section of the wings of this airplane was presumably the Clark YM-15 but the nature of the wing construction was such as to permit of considerable fabric sag with the result that the wing sections were different from the Clark YM-15 section and also from the sections tested in the wind tunnels. An additional effect of the fabric sag was to produce a marked irregularity of the nose portion of the wing midway between the ribs. This irregularity will be discussed later.

The leading-edge modification was built up by bending strips of thin sheet duralumin on the smallest possible radius to form a V and mounting these strips on triangular blocks having one edge formed to fit the nose of the wing. The strips were put in place on the nose of the wing and

made secure with pieces of fabric doped down over the leading-edge strips and back on the upper and lower surfaces of the wing.

The leading-edge strips were of such dimensions and were mounted in such a position on the nose of the wings as to conform with a section derived by choosing a point 2 per cent of the chord ahead of the nose and 3.2 per cent of the chord above the chord line of the basic airfoil, and drawing two straight lines from this point tangent to the upper and lower profile curves. The new profile thus formed, as well as the basic profile, is shown in Figure 9. Ordinates for the basic airfoil are given in reference 4.

The section of the original wing was measured at several representative ribs to determine how uniform the rib shapes were and how well the wing corresponded to the specified ordinates. The results of the measurements were as follows: (a) Aft of the front spar, which is about 11 per cent of the chord back of the leading edge, the deviations of the individual ribs measured from a fair line were small; (b) forward of the front spar the ribs showed deviations of as much as 0.12 inch; and (c) the fair line deviated as much as 0.15 inch from the specified section ordinates. Between the ribs the shape was more irregular than at the ribs. The combined effect of a rather large fabric sag (approximately $\frac{3}{8}$ inch) and a narrow strip of metal used as a nose former caused a sharp break in the wing profile at about 1.25 per cent of the chord back of the leading edge on both the upper and lower surfaces. The photograph, Figure 10, shows this condition.

The instruments for the spin measurements consisted of a specially arranged pin-hole camera which gave measurements of the rate and axis of rotation by recording a trace of the image of the sun, an N.A.C.A. 3-component accelerometer (reference 5), a sensitive altimeter, and a stop watch. The function of the instrument installation was the same as that of reference 6; namely, the complete measurement of forces, angular velocity, and vertical velocity of the spinning airplane, from which the moments, attitude angles, and flight path could be computed. The use of the pin-hole camera represents a departure from the practice described in reference 6, since the three angular velocity recorders were replaced by this instrument. The camera was provided with a tilting base and a rotating-disk shutter so arranged that the rate of rotation and direction of the axis of rotation could be determined from the setting of the camera and

the trace of the sun image on the plate. This camera was operated during only one turn of the spin and since the accelerometer record covered 1,000 feet of spin a means of synchronizing the two instruments was necessary. The synchronization was accomplished by means of an auxiliary light in the accelerometer connected in parallel with the camera shutter circuit.

The instruments were mounted in accordance with the requirements outlined in references 6 and 7, the most important one being that the accelerometer should be mounted a known and small as possible distance from the center of gravity. The pinhole camera was mounted at the trailing edge of the upper wing at the center section to avoid the occurrence of shadows on the camera.

The apparatus used for measuring high speed in level flight and minimum speed in a glide consisted in an N.A.C.A. trailing air-speed head (Pitot-static) connected to an N.A.C.A. recording air-speed meter (reference 8) by means of small rubber tubes attached to the suspension cable. Level flight for the high-speed runs was maintained by means of a sensitive statescope. The other instruments employed were a sensitive altimeter and a thermometer.

The spin tests were made by the same flight procedure as used in the tests of references 6 and 7. Except for the slight difference involved in using the pinhole camera records, the computations were made in the same manner as in references 6 and 7. Since results of tests with several different ballast conditions without the sharp leading-edge strips were available, tests with several ballast conditions were made with the leading-edge strips for comparison.

Because of the occurrence of oscillations in the spins, the tests reported herein were restricted to a smaller number than that preferred for this type of investigation. The oscillations seemed to be induced by the entry unless extreme care was exercised to avoid "whipping," or by atmospheric turbulence at any stage of the spin. Once started, the oscillations would usually persist for the remainder of the spin, but in a few cases the spin became steady after having been unsteady for a number of turns. On account of this tendency to oscillate, the spins were made in still air early in the morning whenever possible.

The high speed in level flight was obtained by taking

the average speed over a 30-second test (made after high-speed equilibrium had been established) in which level flight was maintained by means of a statorscope to approximately 12 feet of altitude. The possible error in these tests resulting from variation of engine performance with air temperature and density was held at a minimum by choosing conditions for tests such that the variation of these factors was very small. The tests were run under practically standard sea-level conditions.

The maximum lift coefficient was calculated from data obtained in glides in which the velocity along the flight path was recorded by means of the instrument connected to the trailing Pitot-static head, and the vertical velocity was determined by timing a 500-foot loss of altitude as indicated by the sensitive altimeter. The minimum air speed and corresponding glide angle were determined from a fair curve drawn through a vector plot of the velocity along the flight path and the vertical component measured in several glides at angles of attack near that for maximum lift coefficient. (Fig. 11.) As C_L at minimum gliding speed is very close to C_{Lmax} (within 0.5 per cent) the calculated value for that condition was taken as the maximum lift coefficient. The airplane weight used in the calculations was corrected for the weight of fuel consumed in flight. During the glides the propeller was operating close to the V/nD for zero thrust.

Precision

The estimated precision of the spin measurements was summarized in reference 7 as follows: "angular velocity, 3 per cent for each component; acceleration 0.05 g; interval of altitude, 5 per cent; weight 1 per cent; moments of inertia 1 per cent." The precision of the angular velocity measurement in the present case is probably slightly better than in former tests owing to the use of the pinhole camera. The improvement is indicated by the fact that the calculated vertical-force component showed less variation from unity than formerly. The estimated precision of the other quantities is as quoted from reference 7.

For comparative purposes the value of V_{max} and C_{Lmax} can be regarded as accurate to within ± 0.6 m.p.h.

and ± 3 per cent, respectively. The absolute values are probably only slightly less accurate.

Results and Discussion

The results of the measurements for the steady spin are given in Table I (airplane condition), II (instrument data), and III (computed results). The effect of the sharp leading edge on recovery was to give a pronounced increase in effectiveness of the controls. With the sharp leading edge in place it was necessary to manipulate the elevator with care to avoid coming out of the spin in a steep dive. In spite of this increased elevator effectiveness approximately the same height was required for recovery with the sharp leading edge as without it.

The performance results are as follows:

	Max. speed m.p.h.	C_{Lmax}
With sharp leading edge	94.0	1.10
Without sharp leading edge	98.2	1.19

The effect of the sharp leading edge on the spin shown by the results in Table III may be summarized as follows: Angle of attack was decreased about 10° for the case of the normal airplane loading (25° for the extreme condition); sideslip changed from inward to outward; rate of rotation decreased to roughly 85 per cent of rate of rotation without the sharp nose. All of these are desirable changes in the spin. The change to outward sideslip is especially desirable, since the effectiveness of the fin and rudder is greater with outward than with inward sideslip. The vertical velocity, on the other hand, was greater with the sharp leading edge than without it. A further result was that with the sharp leading edge the spin was insensitive to the addition of ballast along the lateral axis. This condition

follows from the fact that sideslip was outward and that q , the angular velocity in pitch, was almost zero.

The improved effectiveness of the controls may be expected as a result of the lower angle of attack, and the outward sideslip of the spin as a result of the sharp leading edge. The tendency of the airplane in this condition to terminate the recovery in a steep dive offsets any improvement in altitude required for recovery that may have resulted from the improved control effectiveness. Since in its normal condition the airplane required only a trifle over one turn to recover, it was difficult to detect a real difference in the number of turns for recovery.

The sharp leading edge produced a detrimental effect on the high speed and C_{Lmax} . The reduction in high speed was unexpected inasmuch as the wind-tunnel tests indicated a slightly favorable rather than a detrimental effect on minimum drag. At present no satisfactory explanation of this apparent discrepancy seems possible, although it is worth noting that because of the irregular shape of the airplane wings the sharp nose installation on the airplane can not be considered equivalent to that on the wind-tunnel models. The reduction in C_{Lmax} found in the flight tests agrees with the wind-tunnel results except in magnitude. This difference may be attributed to such factors as bi-plane effect, difference in Reynolds Number, and irregularity of the surfaces of the airplane wings. These disadvantages found with the sharp leading edges indicate a very limited applicability of the device as a method of controlling dangerous spins.

Conclusions

1. A sharp leading edge added to a thick or moderately thick wing produces favorable effects on the spin. It causes a decrease in angle of attack and rate of rotation, induces outward sideslip, and makes the controls more effective.

2. The effect of a sharp leading edge on the general performance of the airplane was unfavorable. The maximum speed was decreased 4 per cent and the value of C_{Lmax} was decreased about 7.5 per cent on the airplane tested.

REFERENCES

1. Jacobs, Eastman N.: The Characteristics of Two Sharp-Nosed Airfoils Having Reduced Spinning Tendencies. T.N. No. 416, N.A.C.A., 1932.
2. Harris, Thomas A.: The 7 by 10 Foot Wind Tunnel of the National Advisory Committee for Aeronautics. T.R. No. 412, N.A.C.A., 1931.
3. Jacobs, Eastman N., and Abbott, Ira H.: The N.A.C.A. Variable-Density Wind Tunnel. T.R. No. 416, N.A.C.A., 1932.
4. Anderson, Raymond F.: The Aerodynamic Characteristics of Airfoils at Negative Angles of Attack. T.N. No. 412, N.A.C.A., 1932.
5. Reid, H. J. E.: The N.A.C.A. Three-Component Accelerometer. T.N. No. 112, N.A.C.A., 1922.
6. Soulé, Hartley A., and Scudder, Nathan F.: A Method of Flight Measurement of Spins. T.R. No. 377, N.A.C.A., 1931.
7. Scudder, Nathan F.: A Flight Investigation of the Spinning of the NY-1 Airplane with Varied Mass Distribution and Other Modifications, and an Analysis Based on Wind-Tunnel Tests. T.R. No. 441, N.A.C.A., 1932.
8. Norton, F. H.: N.A.C.A. Recording Air-Speed Meter. T.N. No. 64, N.A.C.A., 1921.

TABLE I
Airplane Conditions

Group	Test numbers	Ballast position	c.g. per cent mean chord	$\frac{W}{S}$ lb./ft. ²	Momentary ellipsoid constants*				τ deg.
					slug ft. ²	slug ft. ²	slug ft. ²	slug ft. ²	
A	45	10 lb. in rear	38.0	7.95	836	985	1,425	0	} With sharp nose
B	50, 53	134 lb. at wing tips	31.5	8.62	1,252	940	1,796	0	
C	54, 56, 58	48 lb. in rear	40.0	8.20	836	1,150	1,590	0	
D	59	No ballast	31.5	7.95	836	940	1,380	0	} Without sharp nose
B ₀	82, 84, 85	134 lb. at wing tips	31.5	8.88	1,258	943	1,813	0	
C ₀	88, 89, 90	48 lb. in rear	40.0	8.88	842	1,154	1,608	0	
D ₀	38, 40, 41	No ballast	31.5	7.74	829	941	1,384	0	

*See reference 6 for definitions of constants.

TABLE II
Instrument Data

Test No.	Accelerometer readings			Angular velocity readings			Vertical velocity ft./sec.
	$\frac{X}{W}$	$\frac{Y}{W}$	$\frac{Z}{W}$	p rad./sec.	q rad./sec.	r rad./sec.	
45	0.105	0.066	1.43	-1.95	-0.042	-1.85	89.4
50	.078	.032	1.43	-2.14	-.011	-1.91	90.9
53	.094	.024	1.39	-2.08	.023	-1.91	87.0
54	.086	.034	1.28	-1.50	.008	-1.60	84.7
56	.085	.023	1.28	-1.52	.072	-1.62	87.0
58	.089	.030	1.33	-1.55	.059	-1.50	87.0
59	.091	.024	1.35	-2.01	-.068	-1.91	87.7
82	.026	.042	1.14	-1.46	.738	-3.82	66.8
84	.056	.037	1.13	-1.53	.758	-4.32	66.7
85	.042	.054	1.14	-1.46	.770	-4.20	67.6
88	-.172	-.064	1.12	-1.27	.790	-2.76	74.9
89	-.154	-.055	1.15	-1.23	.815	-2.83	75.8
90	-.153	-.022	1.17	-1.37	.719	-2.73	74.7
38	-.054	-.012	1.30	-1.82	.531	-2.54	75.8
40	-.045	-.024	1.30	-1.71	.497	-2.49	73.8
41	-.042	.009	1.31	-1.66	.341	-2.37	75.1

TABLE III

Computed Spin Results

Group	Test numbers	Resultant angular vel. Ω rad./sec.	Angle of attack α_x deg.*	Angle of sideslip β deg.	Glide path angle γ deg.	Velocity along flight path V ft./sec.	Radius ft.	Spin coefficient Λ $\frac{\Omega b}{2V}$	Moment coefficient		
									C_l	C_m	C_n
A	45	2.69	43.1	8.3	-82.6	90.1	4.3	0.416	0.000690	-0.355	-0.000246
B	50, 53	2.84	41.8	7.0	-82.8	89.6	3.9	.444	-.000208	-.330	.000081
C	54, 56 58	2.19	45.3	7.1	-81.8	87.1	5.6	.351	-.000682	-.397	-.000477
D	59	2.77	43.5	8.3	-83.1	88.4	3.8	.439	.00119	-.324	.000297
B _o	82, 84 85	4.44	68.7	-7.7	-87.1	67.1	0.7	.926	-.0975	-.911	.0127
C _o	88, 89 90	3.15	63.4	-9.3	-84.9	75.4	2.2	.586	-.0279	-.739	-.00890
D _o	38, 40 41	3.05	53.8	-2.3	-83.6	75.4	2.8	.565	-.0143	-.578	-.00257

* Angle of attack referred to x axis (parallel to principal axis and thrust line).

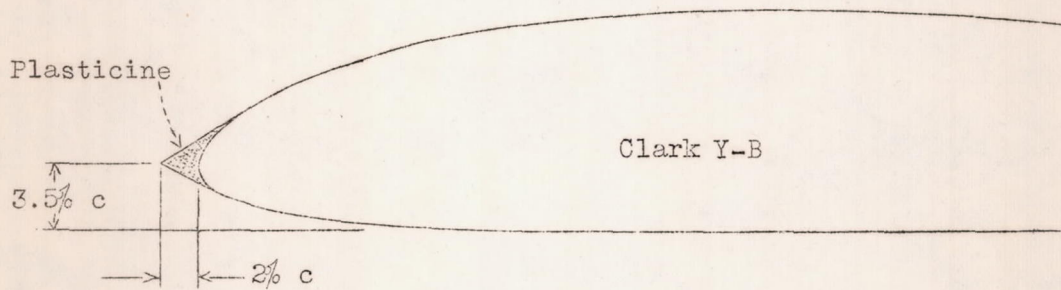
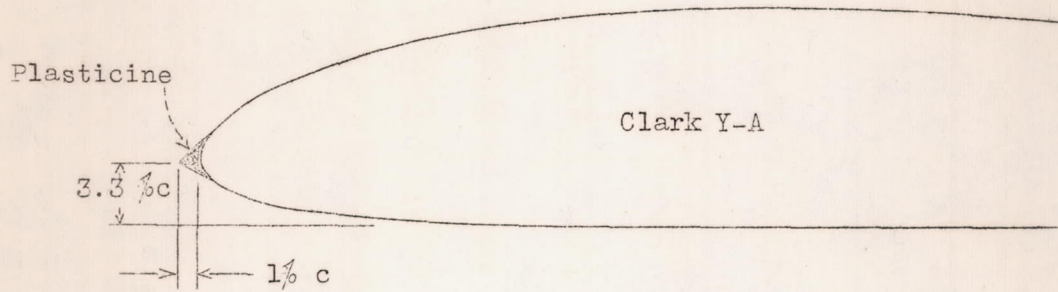

Figure 1.-Sketch showing method of forming sharp leading edges.

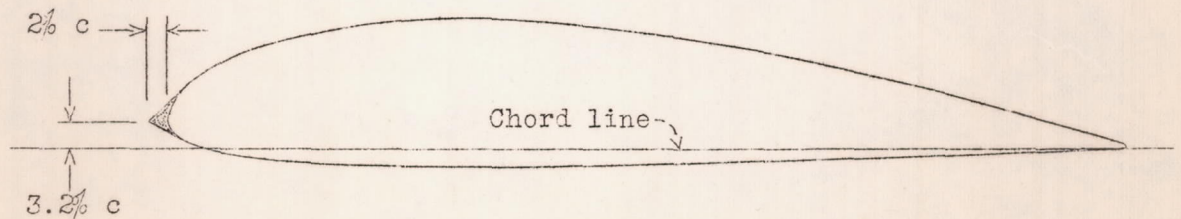

Figure 9.-Clark YM-15 airfoil with 2 per cent chord sharp nose strip added.

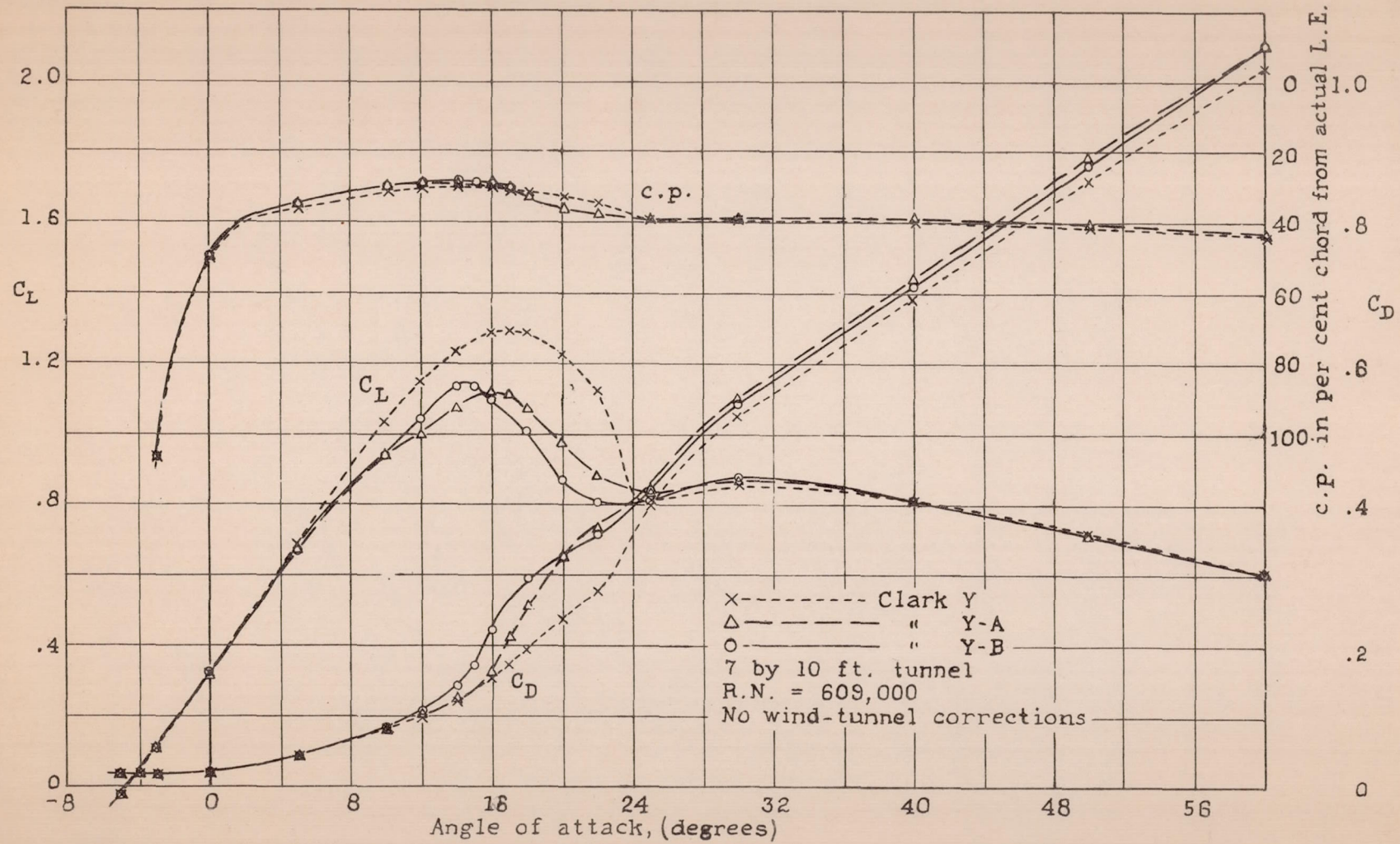

Figure 2.- Aerodynamic characteristics of the Clark Y, Clark Y-A and Clark Y-B airfoils.

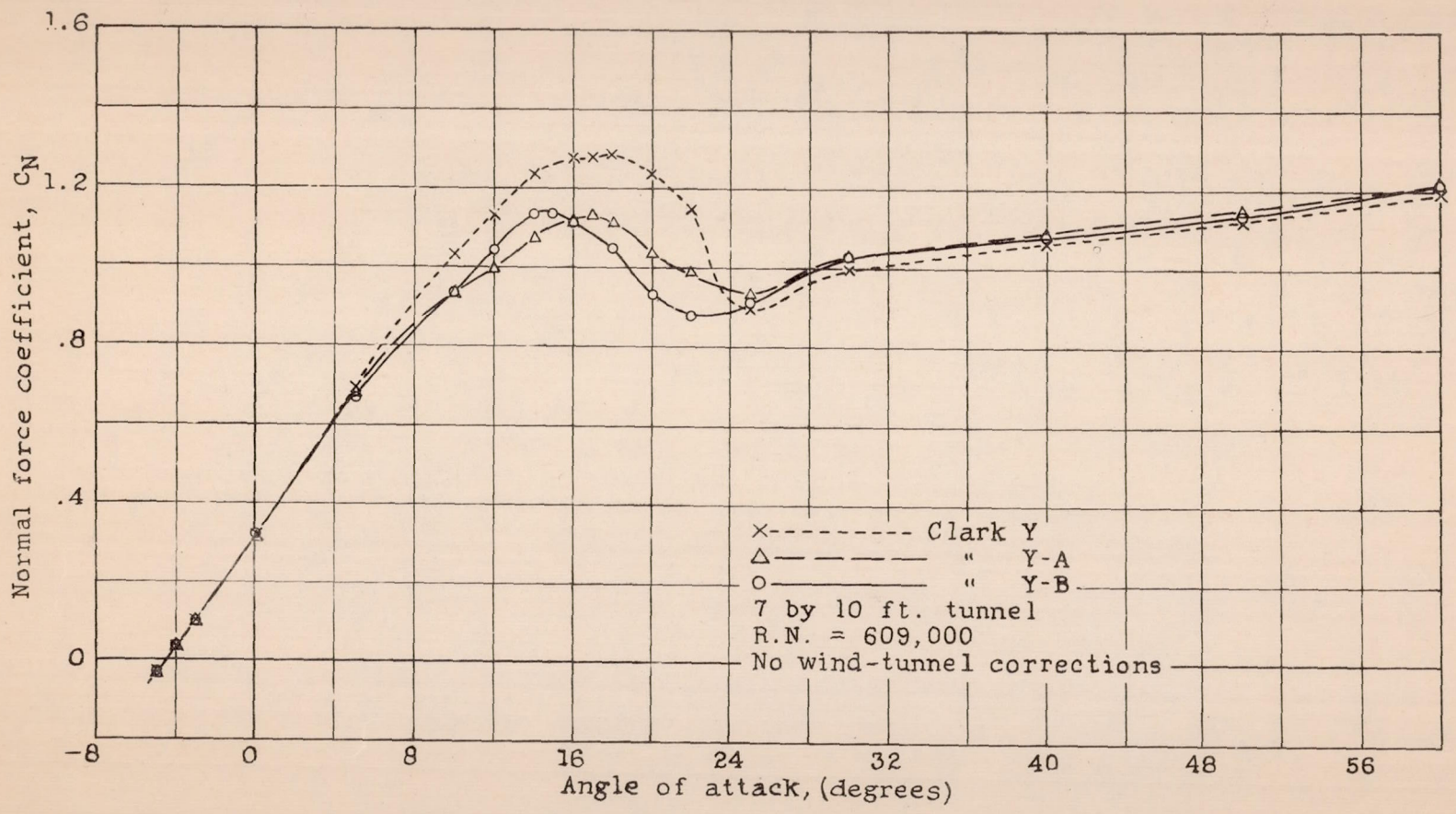
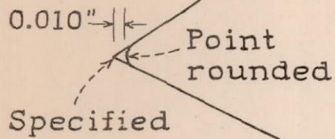

Figure 3. - Variation of normal force coefficient with angle of attack.

Enlarged sketch
of leading
edge



Clark Y-B airfoil
Variable-density tunnel tests

	Pressure	R.N.	Test
Leading edge as specified.	△ 1.00 Atm.	169,000	838-3
	× 3.54 "	609,000	838-1
	○ 20.5 "	3,120,000	838-2
Leading edge, point rounded	▽ 1.00 Atm.	164,000	846-2
	----- 20.8 "	3,100,000	846-1

No wind-tunnel corrections

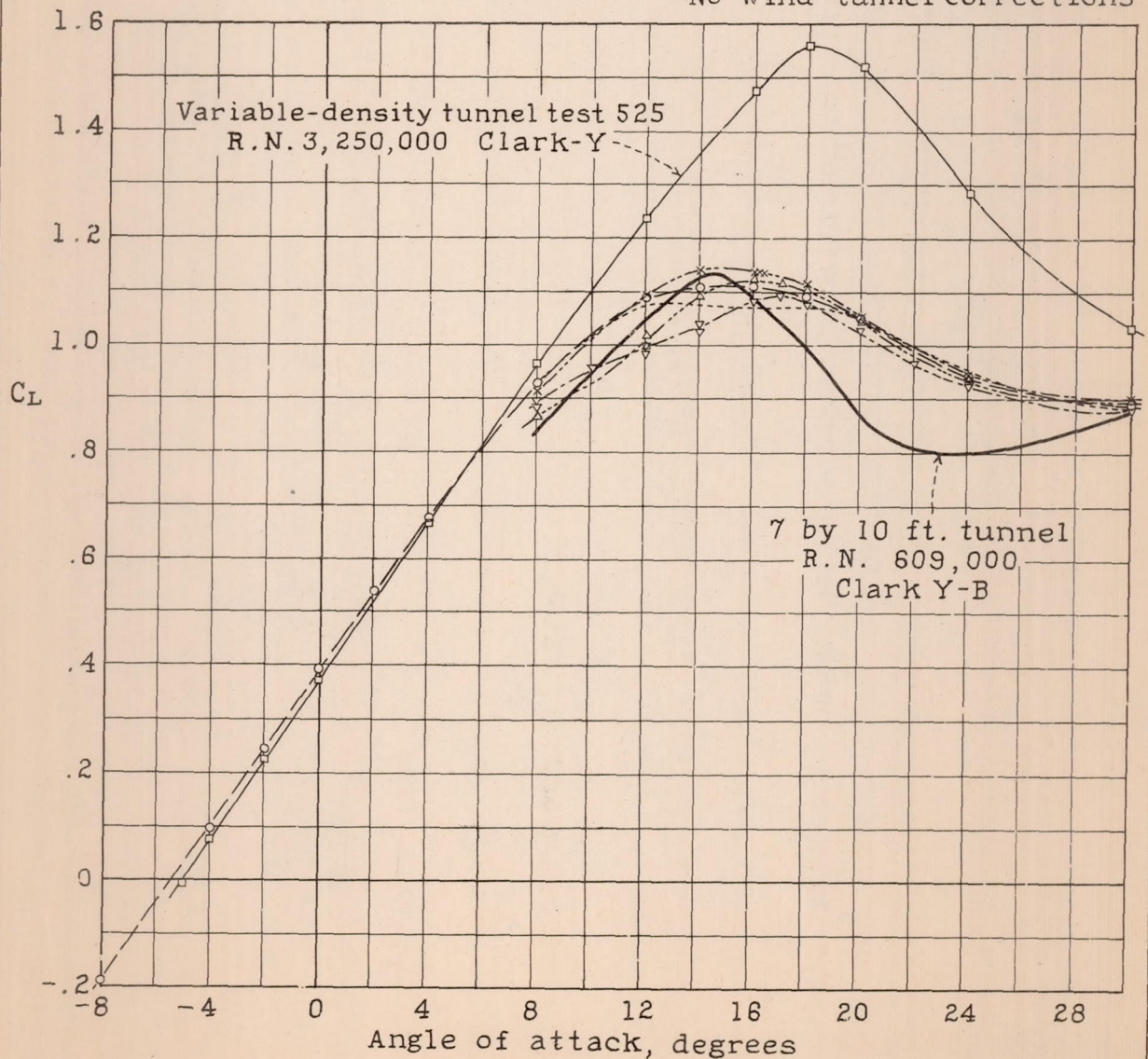

Figure 4.-Comparison of lift curves for the airfoils tested under different conditions

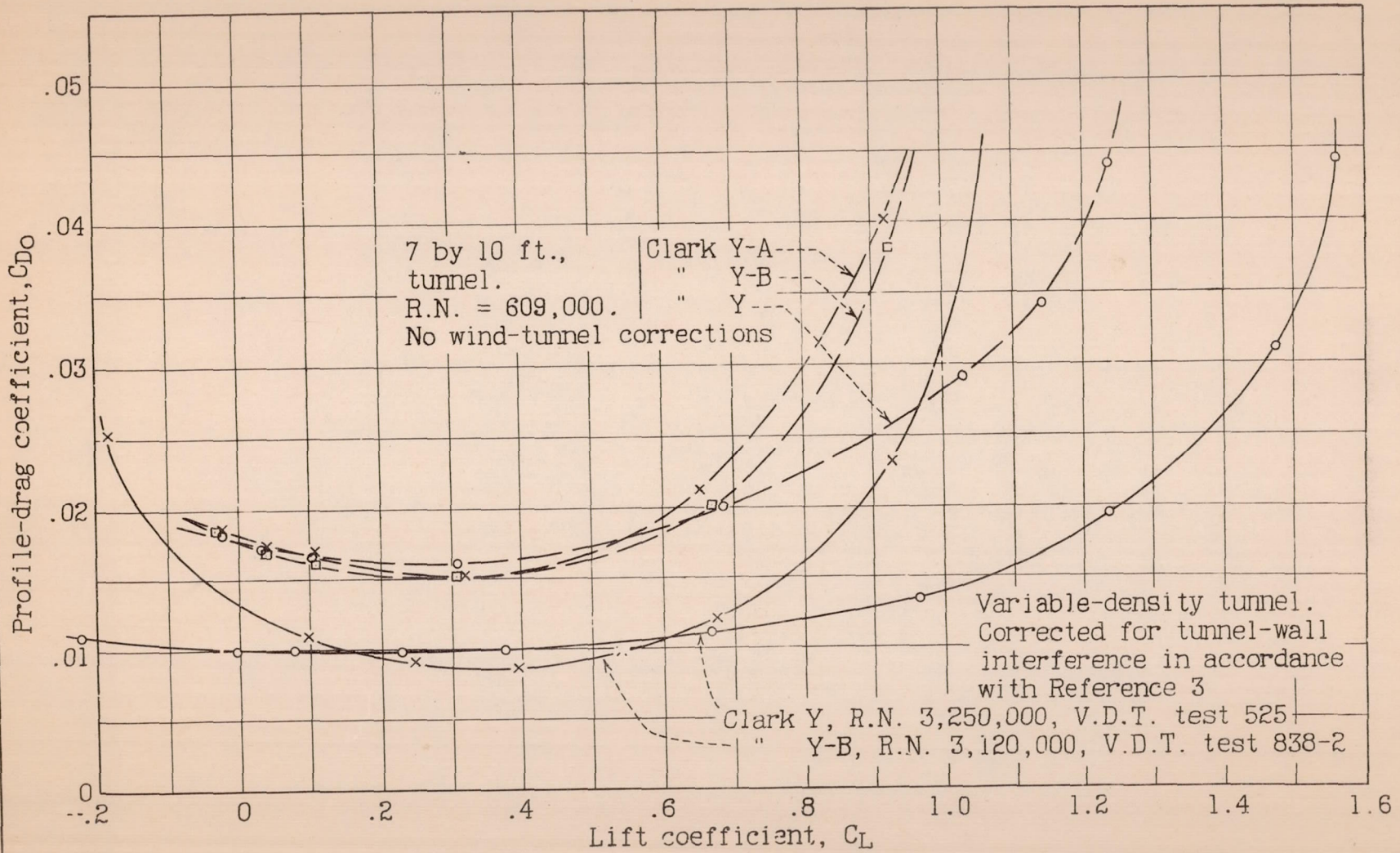

Figure 5 -Profile drag

20

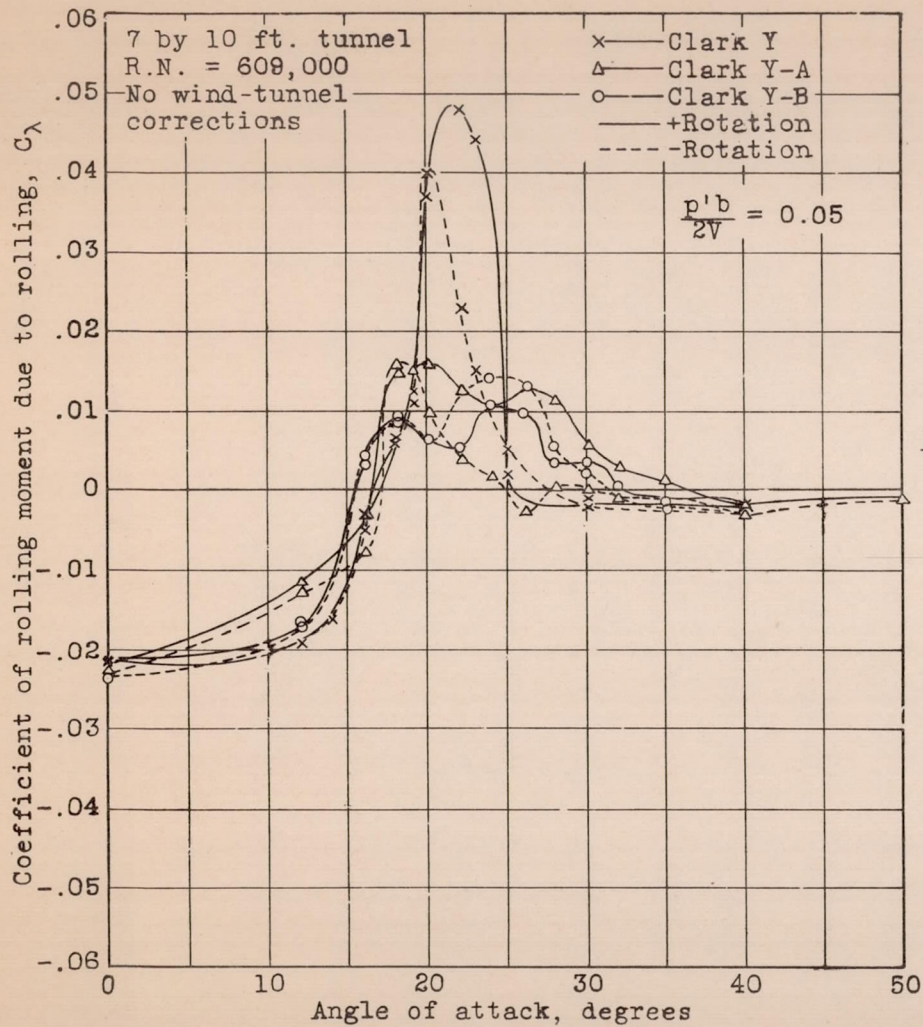

Figure 6.—Variation of rolling moment due to rolling with angle of attack. Forced rotation tests.

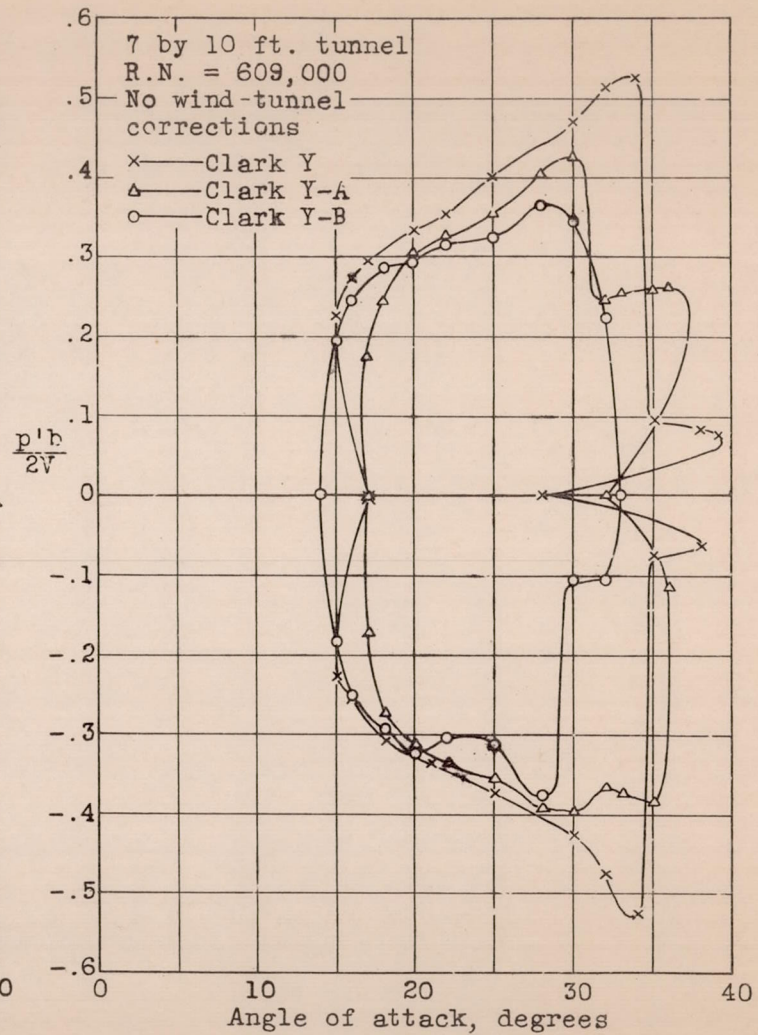
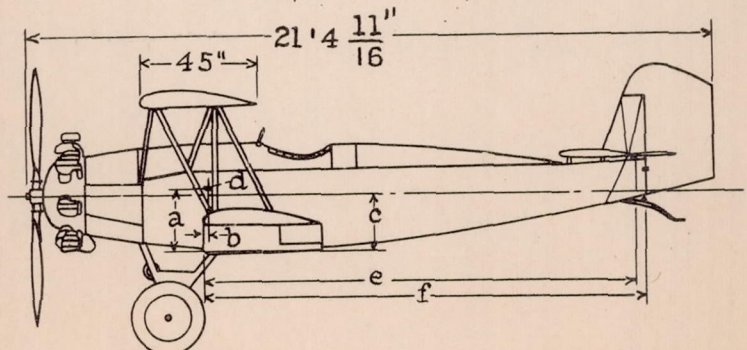
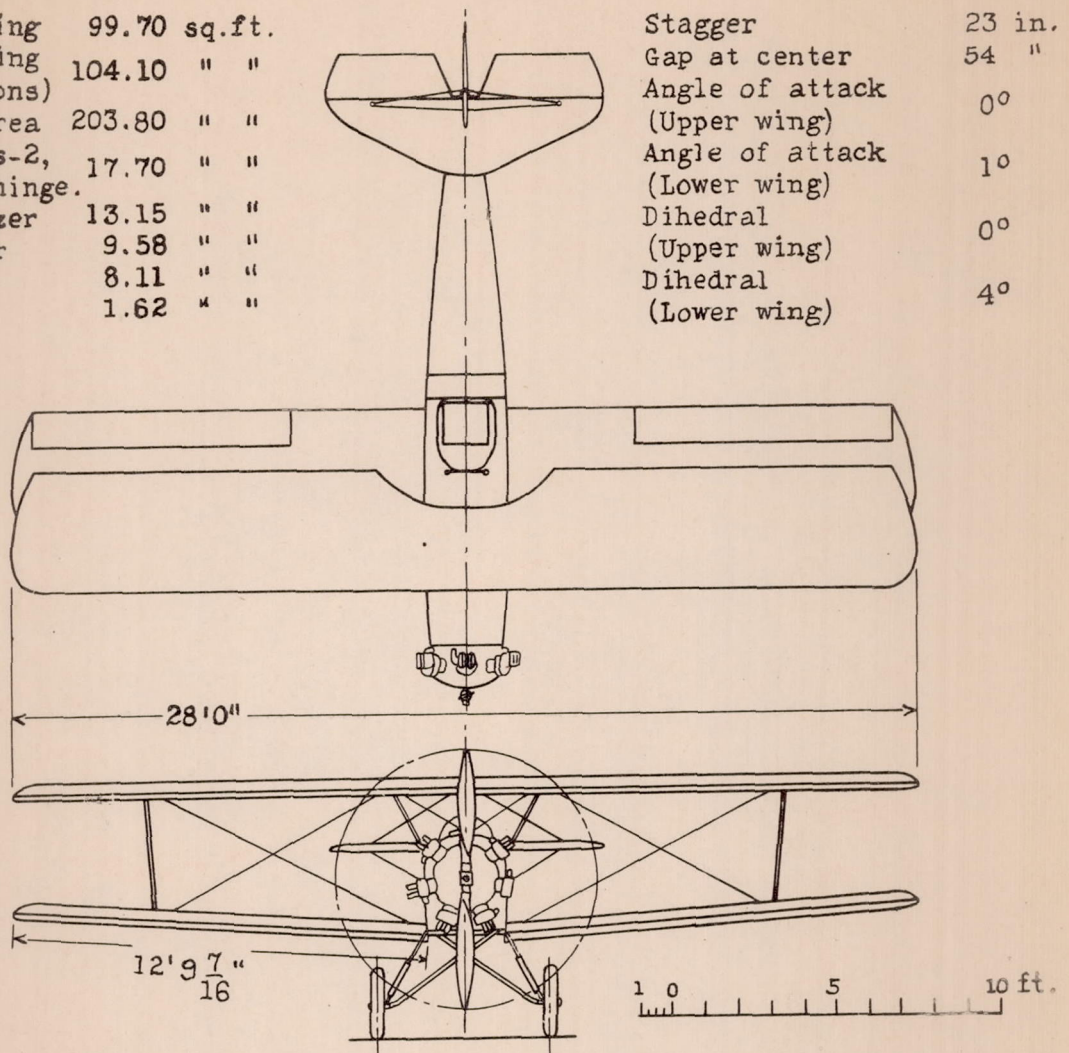

Figure 7.—Variation of the ratio $\frac{p'b}{2V}$ with angle of attack. Free rotation tests.

12

Upper wing	99.70	sq.ft.
Lower wing	104.10	" "
(& ailerons)		
Total area	203.80	" "
Ailerons-2,	17.70	" "
aft of hinge.		
Stabilizer	13.15	" "
Elevator	9.58	" "
Rudder	8.11	" "
Fin	1.62	" "

Stagger	23 in.
Gap at center	54 "
Angle of attack	0°
(Upper wing)	
Angle of attack	1°
(Lower wing)	
Dihedral	0°
(Upper wing)	
Dihedral	4°
(Lower wing)	



a, $20 \frac{15}{16}$ " b, $2 \frac{1}{4}$ " c, $22 \frac{1}{32}$ " d, c.g. e, $13'6 \frac{3}{8}$ " f, $13'10 \frac{3}{8}$ "

Figure 8.-Three-view drawing of XN2Y-1 airplane.

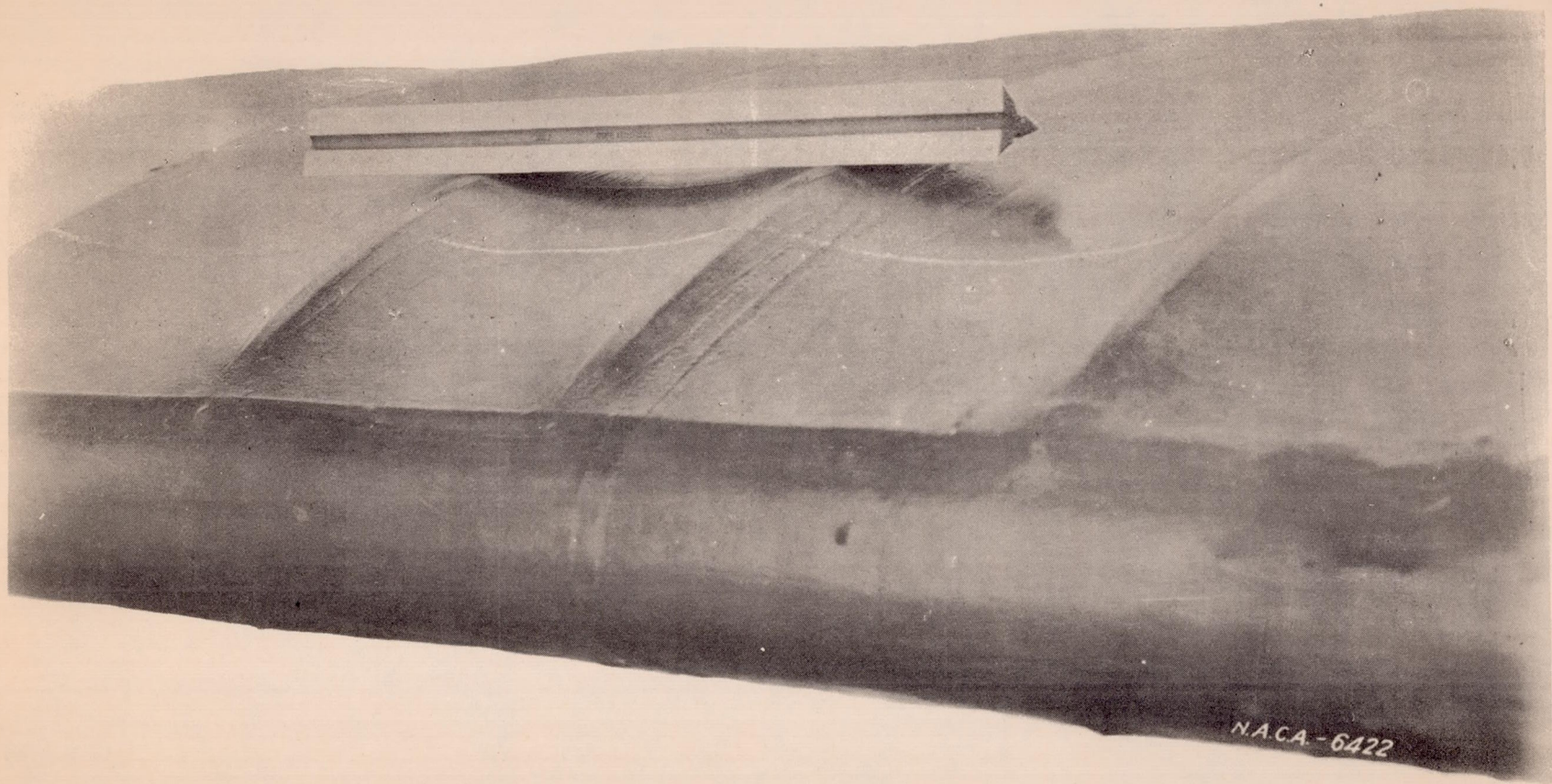

FIG. 10

Figure 10.-Nose of airplane wing before the addition of the sharp leading edge.

23

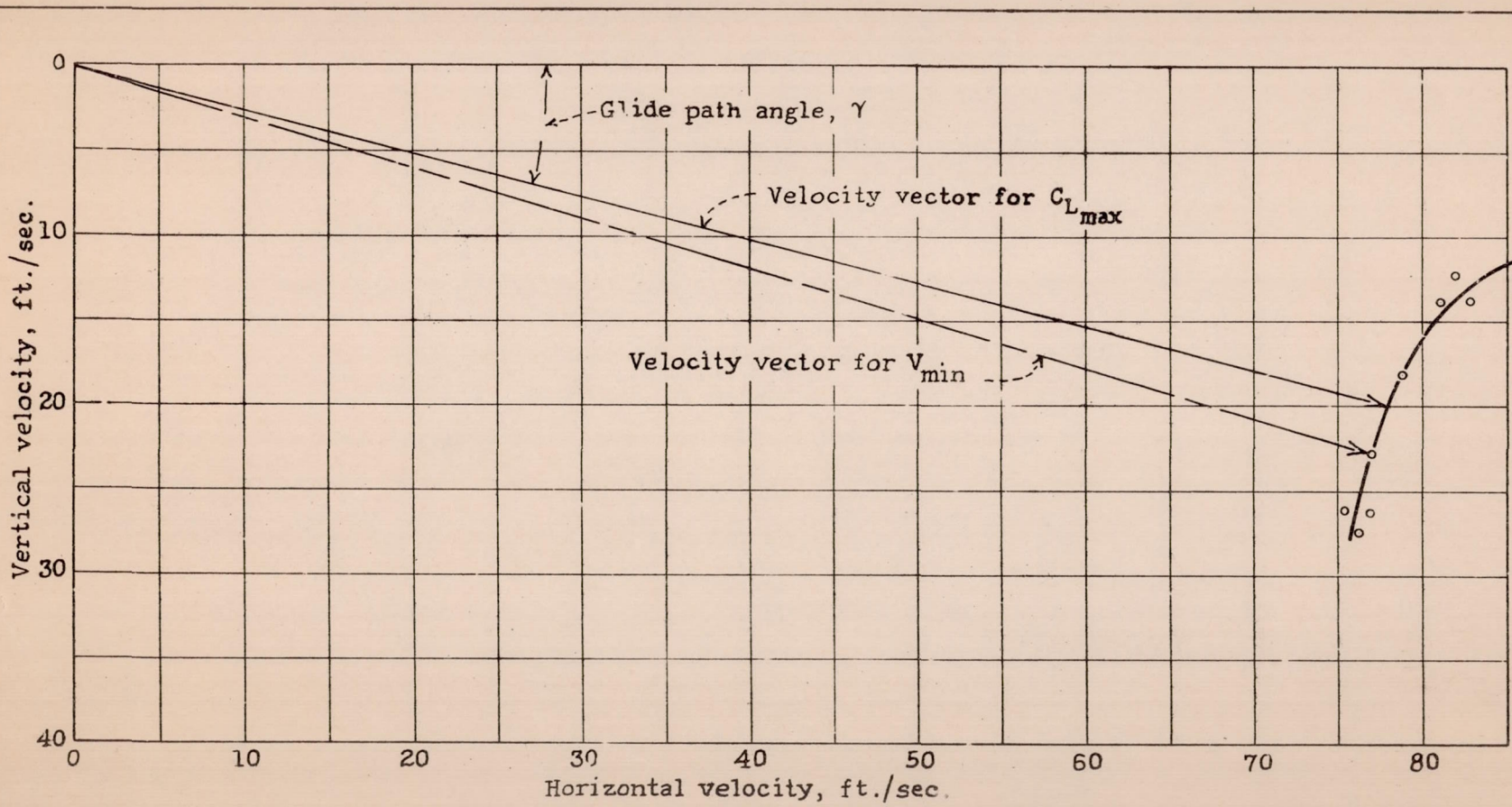

Figure 11 - Typical velocity diagram for XN2Y-1 airplane.

24