

POST OFFICE
AERONAUTICS

MAILED

AUG 28 1931

L. M. L.

Langley 11/3/31
74

TECHNICAL NOTES

NATIONAL ADVISORY COMMITTEE FOR AERONAUTICS

No. 387

THE PRESSURE DISTRIBUTION OVER A MODIFIED ELLIPTICAL
WING TIP ON A BIPLANE IN FLIGHT

By Richard V. Rhode and Eugene E. Lundquist
Langley Memorial Aeronautical Laboratory

FILE COPY

To be returned to
the files of the Langley
Memorial Aeronautical
Laboratory.

Washington
August, 1931



NATIONAL ADVISORY COMMITTEE FOR AERONAUTICS

TECHNICAL NOTE NO. 387

THE PRESSURE DISTRIBUTION OVER A MODIFIED ELLIPTICAL
WING TIP ON A BIPLANE IN FLIGHT

By Richard V. Rhode and Eugene E. Lundquist

SUMMARY

This note presents the results of flight pressure-distribution tests on the right upper wing panel of a Douglas M-3 airplane equipped with a modified elliptical tip having a slight amount of washout.

The results are given in tables and curves in such form that the load distribution for any normal force coefficient within the usual range encountered in flight may be determined.

The test results presented here were obtained at Langley Field, Va., by the National Advisory Committee for Aeronautics in April and May, 1931.

Introduction

To supply reliable and systematic information on the effect of changes in wing-tip plan form on the load distribution, a flight investigation of the pressure distribution over wing tips has been undertaken by the National Advisory Committee for Aeronautics at Langley Field, Va. This investigation has been outlined to include pressure measurements on the right upper panel of a Douglas M-3 airplane with several variations in tip form. These variations are systematic in the main, but also include a few odd shapes, either because such forms are commonly used or because information of value could be obtained with little additional work.

The results of tests on four tips have already been reported: The "Douglas" tip in reference 1; the square tip with faired end and the square tip without faired end,

in reference 2; and the semicircular tip in reference 3. This paper, the fourth in the series, comprises the data obtained on a modified elliptical tip having a slight amount of washout.

During these tests a rounded tip of the "Douglas" form (see reference 1) was used on the right lower panel. However, as was shown in previous tests (reference 2), the results obtained on the upper wing may be considered as unaffected by the shape of the lower tip.

Methods and Apparatus

The M-3 airplane used in these tests is a normal biplane having, however, an aspect ratio somewhat higher than usual. The characteristics of this airplane are given in Table I. The shape of the wing-tip plan form is given in Figure 1 and the ordinates of the profiles in Table II. The Clark Y section was maintained throughout the span. The sections were so located vertically that the points of maximum mean camber lay in a plane parallel to the main chord of the wing.

The wings were rigged with a washin of about 0.2° independent of the washed-out tip. Deflection measurements previously made (reference 1) indicated that this amount would be sufficient to approximately cancel the torsional deflection at the low angles of attack. However, at high angles of attack the torsional deflection is virtually zero (reference 1), and the rigged washin therefore resulted in an "effective twist." This twist was such a small percentage of the high angles of attack that it had a negligible influence on the results, and consequently they can be considered to represent closely the conditions for zero wing twist throughout the investigated range of angle of attack.

The same procedure was followed in these tests as was used in previous tests in this series. (See references 1, 2, and 3.) As in the case of the square and semicircular tips, the extra pressure rib X was connected in place of rib C in approximately one-half of the runs. Although it was not possible to measure simultaneously the pressures at ribs X and C, sufficient information was obtained on both ribs to establish the span load and the moment curves at stations X and C.

Precision

The discussion of precision given in reference 1 applies to the measurements presented herein as no changes have been made in apparatus, method, or procedure.

Results

The results are given in Figures 2a to 4, inclusive, and in Tables IV, V, and VI. The coefficients there referred to are defined as follows:

$$\text{Wing } C_N = \frac{\text{wing normal force}}{q \times \text{wing area}}$$

$$\text{Rib } C_N = \frac{\text{rib normal force}}{q \times \text{rib chord}}$$

$$\text{Rib } C_M = \frac{\text{moment of rib normal force about rib L.E.}}{q \times (\text{rib chord})^2}$$

Figures 2a to 2j, inclusive, show representative pressure plots throughout the range of C_N investigated; the pressures for these cases are tabulated in Table IV. Figures 3 and 4 show the variation of rib C_N with wing C_N and rib C_M with rib C_N , respectively. These curves were established by a large number of points, as in Figures 6 and 7 of reference 1, but the points were omitted to avoid confusion. The curves for the root section were obtained by extrapolating span C_N curves and span C_M curves from considerable data. Owing to the extrapolation, the curves do not represent the true conditions near the fuselage and in the slipstream, but they represent more nearly the ideal conditions in which there is no effect from fuselage and propeller.

Tables V and VI give coordinates of the curves of Figures 3 and 4 to allow their construction on a larger and more accurate scale, if so desired. To use Figures 3

and 4: for any wing C_N (or, practically speaking, for any wing lift coefficient) the span- C_N distribution may be obtained from Figure 3 by plotting the corresponding values of rib C_N at their proper locations on the span base line as determined from Figure 1. The values of rib C_M corresponding to these values of rib C_N may be determined from Figure 4, and the center of pressure locus can be drawn from the relation $C_D = C_M/C_N$. To obtain the span-load distribution, the ordinates of the span- C_N curve must be reduced at the tip in the same ratio as the reduction in chord length.

Langley Memorial Aeronautical Laboratory,
National Advisory Committee for Aeronautics,
Langley Field, Va., July 30, 1931.

References

1. Rhode, Richard V., and Lundquist, Eugene E.: The Pressure Distribution over a Douglas Wing Tip on a Biplane in Flight. N.A.C.A. Technical Note No. 347, August, 1930.
2. Rhode, Richard V., and Lundquist, Eugene E.: The Pressure Distribution over a Square Wing Tip on a Biplane in Flight. N.A.C.A. Technical Note No. 360, January, 1931.
3. Rhode, Richard V., and Lundquist, Eugene E.: The Pressure Distribution over a Semicircular Wing Tip on a Biplane in Flight. N.A.C.A. Technical Note No. 379, May, 1931.

TABLE I

Characteristics of Douglas M-3 Airplane

Type - - - - -	Biplane
Airfoil - - - - -	Clark Y
Span (upper and lower) - - - - -	45 ft. 10 in.
Chord (upper and lower) - - - - -	5 ft. 8 in.
Gap - - - - -	6 ft. 0 in.
Stagger - - - - -	None
C.G. in per cent of chord - - - - -	29

	Original	*Modified elliptical
Areas (sq.ft.):		Right upper
Right upper wing, including aileron - - - - -	126.4	125.2
Right lower wing, including aileron - - - - -	126.4	126.4
Total wing area - - - - -	505.6	504.4
Horizontal tail surfaces - - - - -		58
Vertical tail surfaces - - - - -		17.7
Weight during tests - - - - -		4,840 lb.
Engine - - - - -		Liberty
Rated hp at 1,750 r.p.m. - - - - -		420
Power loading - - - - -		11.52 lb./hp
Wing loading - - - - -		9.57 lb./sq.ft.

*Left wing panels remain unchanged.

TABLE II

Ordinates of Pressure Ribs

Sta- tion in % chord	Clark Y		Rib X		Rib A		Rib B		Rib C		Rib D		Rib E		Rib F	
	Upper	Lower	Upper	Lower	Upper	Lower	Upper	Lower	Upper	Lower	Upper	Lower	Upper	Lower	Upper	Lower
0.00	3.50	3.50	3.40	3.40	3.49	3.49	3.36	3.36	3.49	3.49	3.11	3.11	3.19	3.19	3.85	3.85
1.25	5.45	1.93	5.47	1.84	5.56	1.93	5.34	1.79	5.42	1.84	5.53	1.80	5.62	1.91	5.78	2.47
2.50	6.50	1.466	6.53	1.29	6.52	1.47	6.38	1.33	6.43	1.38	6.46	1.26	6.54	1.28	6.78	1.94
5.00	7.90	.933	7.90	.87	8.00	.97	7.90	.83	8.00	.87	7.86	.78	7.99	.82	8.07	1.20
7.50	8.25	.629	8.22	.51	9.05	.65	8.91	.28	8.96	.46	8.79	.48	9.04	.46	8.99	.91
10.00	9.60	.42	9.65	.41	9.74	.46	9.65	.32	9.65	.32	9.52	.25	9.73	.24	9.63	.73
15.00	10.695	.15	10.61	.18	10.76	.28	10.67	.14	10.62	.18	10.48	.05	10.54	.00	10.66	.47
20.00	11.26	.053	11.21	.05	11.26	.09	11.26	.05	11.26	.05	11.12	.00	11.12	-.17	11.27	.26
30.00	11.70	.00	11.67	.00	11.73	.00	11.81	.00	11.81	.00	11.55	.00	11.58	-.17	11.92	.09
40.00	11.40	.00	11.30	.00	11.36	.00	11.40	.05	11.45	.00	11.16	.05	11.23	-.11	11.86	.00
50.00	10.515	.00	10.48	.00	10.48	.00	10.58	.03	10.58	.05	10.29	.05	10.54	-.11	10.74	.00
60.00	9.148	.00	9.19	.00	9.19	-.05	9.42	.09	9.25	.14	8.84	.00	9.15	-.17	9.37	.00
65.00	8.30	.00	8.27	.05	8.27	.00	8.54	.09	8.45	.14	8.06	.05	8.34	-.17	8.63	.00
70.00	7.55	.00	7.35	.09	7.36	.00	7.68	.09	7.67	.14	7.08	.20	7.41	-.17	7.90	.00
80.00	5.216	.00	5.38	.00	5.33	.00	5.65	.18	5.70	.23	5.48	.43	5.34	-.17	5.70	.00
90.00	2.802	.00	2.90	.00	2.80	-.05	3.51	.23	3.31	.18	3.68	.73	3.02	-.17	3.76	-.09
95.00	1.494	.00	1.65	.00	1.52	-.09	2.02	.14	2.02	.09	2.58	.73	1.80	-.17	2.76	-.09
100.00	.12	.00	.37	.00	.23	-.23	.74	.00	.65	.00	1.16	.68	.41	-.24	1.12	-.26

Note: All ordinates given are in per cent of chord.

TABLE III

Orifice Locations in Per Cent Chord

Orifice No.	Rib						
	X	A	B	C	D	E	F
1	1.47	1.54	1.47	1.47	1.51	1.91	3.02
2	2.94	3.06	2.94	3.02	2.95	7.01	5.29
3	4.41	4.45	4.41	4.49	4.42	8.86	7.05
4	6.62	6.69	6.70	6.69	10.84	10.81	9.34
5	13.24	13.31	13.30	13.30	18.60	16.42	14.33
6	25.00	25.00	25.00	25.00	27.87	21.96	26.07
7	41.18	41.30	41.40	41.30	41.90	33.23	40.70
8	58.95	59.50	59.10	58.80	60.50	49.95	58.40
9	72.30	73.70	72.00	72.30	82.20	66.50	76.10
10	94.20	94.40	94.50	94.40	---	83.30	---

TABLE IV

Recorded Pressures in Multiples of q

Wing $C_N = -0.02$						
Orifice	Rib					
	X	A	B	D	E	F
1	-2.15	-2.12	-2.24	-2.09	-2.11	-1.61
2	-1.72	-1.50	-1.41	-1.77	-.72	-1.34
3	-1.08	-1.05	-.92	-1.06	-.48	-.82
4	-.65	-.70	-.63	-.38	-.39	-.62
5	-.21	-.23	-.27	-.08	-.08	-.28
6	.20	.13	.15	.13	.02	.21
7	.07	.27	.28	.22	.13	.22
8	.20	.30	.21	.12	.23	.19
9	.14	.12	.16	.05	.19	.09
10	.05	.08	.05	--	.09	--

TABLE IV (cont.)

Recorded Pressures in Multiples of q

Wing $C_N = 0.08$						
Orifice	Rib					
	X	A	B	D	E	F
1	-1.50	-1.75	-1.63	-1.49	-1.59	-1.24
2	-1.16	-1.06	-.97	-1.40	-.46	-.95
3	-.60	-.66	-.51	-.69	-.31	-.60
4	-.26	-.36	-.34	-.19	-.21	-.42
5	.04	.02	-.11	.08	.05	-.15
6	.38	.24	.29	.18	.15	.16
7	.14	.31	.35	.23	.20	.24
8	.23	.21	.21	.08	.22	.17
9	.17	.14	.14	.08	.17	.12
10	.06	.07	.07	--	.10	--

TABLE IV (cont.)

Recorded Pressures in Multiples of q

Wing $C_M = 0.22$						
Orifice	Rib					
	X	A	B	D	E	F
1	-0.51	-0.79	-1.01	-0.90	-1.02	-0.58
2	-.37	-.40	-.46	-.85	-.09	-.56
3	.09	.03	.08	-.24	.04	-.30
4	.28	.19	.12	.07	.09	-.17
5	.40	.38	.19	.21	.27	.06
6	.62	.42	.41	.34	.26	.32
7	.27	.43	.41	.33	.24	.29
8	.30	.27	.21	.11	.26	.18
9	.20	.18	.15	.09	.18	.12
10	.06	.08	.08	--	.09	--

TABLE IV (Cont.)

Recorded Pressures in Multiples of q

Wing $C_M = 0.40$						
Orifice	Rib					
	A	B	C	D	E	F
1	0.17	-0.04	-0.11	-0.10	-0.37	-0.17
2	.33	.20	.04	-.17	.24	-.09
3	.49	.48	.31	.20	.40	.03
4	.59	.52	.45	.43	.39	.06
5	.71	.40	.55	.49	.44	.28
6	.58	.57	.48	.55	.44	.46
7	.70	.55	.36	.44	.40	.39
8	.35	.32	.30	.21	.40	.24
9	.26	.20	.25	.12	.25	.19
10	.09	.06	.07	--	.13	--

TABLE IV (cont.)

Recorded Pressures in Multiples of q

Wing $C_N = 0.60$						
Orifice	Rib					
	A	B	C	D	E	F
1	1.23	0.81	0.79	0.86	0.49	0.46
2	1.28	1.04	.82	.64	.81	.51
3	1.40	1.23	1.00	.99	.91	.49
4	1.48	1.15	1.08	.85	.78	.44
5	1.20	.78	.88	.74	.74	.59
6	.87	.83	.73	.73	.66	.64
7	.86	.67	.47	.56	.55	.48
8	.43	.38	.38	.28	.48	.32
9	.32	.23	.26	.14	.27	.25
10	.09	.06	.06	--	.16	--

TABLE IV (cont.)

Recorded Pressures in Multiples of q

Wing $C_F = 0.78$						
Orifice	Rib					
	X	A	B	D	E	F
1	2.64	2.05	1.46	1.36	1.03	0.99
2	2.24	2.04	1.69	1.23	1.16	1.00
3	2.30	2.04	1.74	1.39	1.23	.91
4	2.18	1.97	1.56	1.14	1.18	.71
5	1.73	1.59	1.13	1.03	.98	.87
6	1.45	1.15	1.10	.86	.85	.90
7	1.26	.93	.79	.67	.64	.62
8	.59	.51	.42	.30	.55	.36
9	.42	.36	.24	.15	.35	.31
10	.13	.08	.06	--	.21	--

TABLE IV (cont.)

Recorded Pressures in Multiples of q

Wing $C_N = 0.93$						
Orifice	Rib					
	X	A	B	D	E	F
1	3.69	3.19	2.38	2.47	1.88	1.57
2	3.09	2.80	2.42	1.96	1.70	1.65
3	2.97	2.67	2.50	2.05	1.64	1.39
4	2.75	2.62	2.21	1.53	1.74	1.07
5	2.04	2.00	1.48	1.14	1.19	1.09
6	1.68	1.31	1.23	.98	1.04	1.03
7	.87	1.02	.87	.74	.74	.67
8	.65	.58	.45	.34	.54	.42
9	.44	.40	.31	.16	.37	.36
10	.15	.10	.13	--	.19	--

TABLE IV (cont.)

Recorded Pressures in Multiples of q

Wing $C_N = 1.15$						
Orifice	Rib					
	A	B	C	D	E	F
1	4.13	3.15	3.15	3.32	2.75	2.24
2	3.80	3.36	2.80	2.69	2.25	2.11
3	3.60	3.27	2.86	2.79	2.23	1.98
4	3.51	3.02	2.79	2.00	1.93	1.55
5	2.52	2.01	1.85	1.39	1.50	1.45
6	1.61	1.41	1.37	1.21	1.30	1.26
7	1.30	1.01	.72	.89	.99	.90
8	.62	.49	.35	.50	.74	.72
9	.38	.28	.34	.23	.49	.73
10	.07	--	.11	--	.27	--

TABLE IV (cont.)

Recorded Pressures in Multiples of q

Wing $C_M = 1.38$						
Orifice	Rib					
	A	B	C	D	E	F
1	5.34	4.11	4.09	4.34	3.64	3.17
2	4.89	4.41	3.90	3.58	2.86	3.02
3	4.55	4.22	3.74	3.62	2.79	2.44
4	4.26	3.96	3.37	2.49	2.45	2.04
5	3.06	2.47	2.37	1.88	1.88	2.09
6	2.02	1.82	1.66	1.44	1.66	1.62
7	1.31	1.11	.85	1.05	1.08	1.20
8	.66	.48	.57	.50	.83	.91
9	.44	.26	.35	.25	.58	1.40
10	.16	.23	.15	--	.31	--

TABLE IV (cont.)

Recorded Pressures in Multiples of q

Wing $C_M = 1.65$						
Orifice	Rib					
	X	A	B	D	E	F
1	7.46	6.85	5.23	5.21	4.61	4.50
2	6.79	6.29	5.08	4.61	3.81	3.89
3	6.42	5.78	5.21	4.47	3.36	3.32
4	5.59	5.31	4.82	3.10	3.05	2.86
5	3.84	3.83	3.25	2.23	2.42	2.37
6	2.29	2.37	1.98	1.73	2.03	1.90
7	1.36	1.52	1.27	1.22	1.45	1.40
8	.75	.77	.61	.59	1.08	1.18
9	.71	.53	.46	.38	.88	1.53
10	.51	.31	.21	--	.58	--

TABLE V
Coordinates of Curves of Figure 3

Wing C _N	Rib C _N							
	Root	X	A	B	C	D	E	F
0	0.010	0.010	0.010	0.005	-0.006	-0.019	-0.037	-0.039
.1	.125	.122	.113	.088	.072	.055	.037	.010
.2	.240	.234	.216	.171	.151	.127	.110	.066
.3	.355	.346	.318	.254	.228	.201	.182	.128
.4	.470	.458	.421	.335	.305	.274	.256	.199
.5	.586	.571	.524	.418	.381	.348	.331	.274
.6	.701	.683	.627	.501	.462	.427	.407	.360
.7	.813	.795	.730	.588	.543	.507	.488	.446
.8	.931	.907	.832	.671	.627	.583	.568	.540
.9	1.046	1.019	.935	.758	.711	.671	.651	.648
1.0	1.161	1.131	1.038	.846	.794	.755	.736	.761
1.1	1.276	1.243	1.141	.931	.876	.840	.826	.880
1.2	1.390	1.354	1.242	1.017	.960	.924	.920	1.006
1.3	1.500	1.451	1.343	1.109	1.044	1.011	1.019	1.139
1.4	1.605	1.568	1.446	1.202	1.135	1.102	1.121	1.280
1.5	1.700	1.663	1.549	1.300	1.230	1.196	1.230	1.423
1.6	1.786	1.754	1.648	1.403	1.332	1.292	1.355	1.570

TABLE VI

Coordinates of Curves of Figure 4

Rib C_N	Rib C_M							
	Root	X	A	B	C	D	E	F
0	-0.071	-0.070	-0.069	-0.065	-0.063	-0.060	-0.056	-0.043
.1	-.094	-.092	-.091	-.085	-.083	-.076	-.076	-.065
.2	-.116	-.114	-.112	-.105	-.102	-.093	-.097	-.090
.3	-.139	-.137	-.133	-.125	-.122	-.111	-.120	-.118
.4	-.161	-.158	-.155	-.144	-.142	-.131	-.143	-.149
.5	-.184	-.181	-.176	-.164	-.161	-.151	-.167	-.182
.6	-.206	-.202	-.198	-.184	-.181	-.173	-.193	-.217
.7	-.229	-.224	-.219	-.203	-.201	-.195	-.219	-.254
.8	-.251	-.246	-.240	-.223	-.221	-.218	-.246	-.291
.9	-.274	-.268	-.262	-.243	-.240	-.242	-.274	-.330
1.0	-.296	-.290	-.283	-.262	-.260	-.267	-.303	-.369
1.1	-.319	-.312	-.305	-.282	-.280	-.292	-.333	-.409
1.2	-.341	-.334	-.326	-.302	-.300	-.317	-.363	-.448
1.3	-.364	-.356	-.348	-.322	-.319	-.343	-.394	-.490
1.4	-.386	-.378	-.369	-.341	--	--	-.426	-.531
1.5	-.409	-.400	-.390	--	--	--	--	-.572
1.6	-.431	-.422	-.412	--	--	--	--	--
1.7	-.454	-.444	--	--	--	--	--	--
1.8	-.476	--	--	--	--	--	--	--

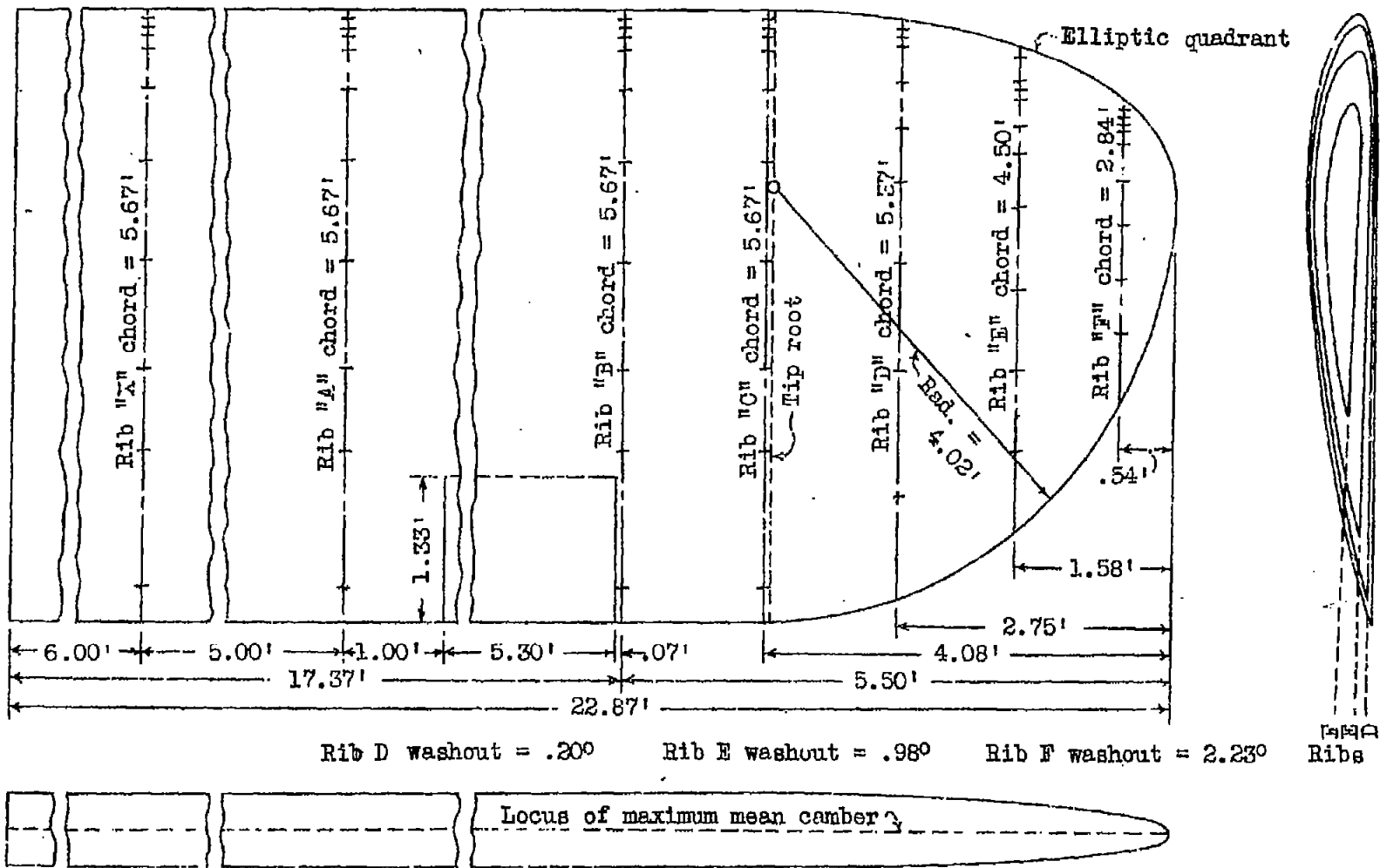
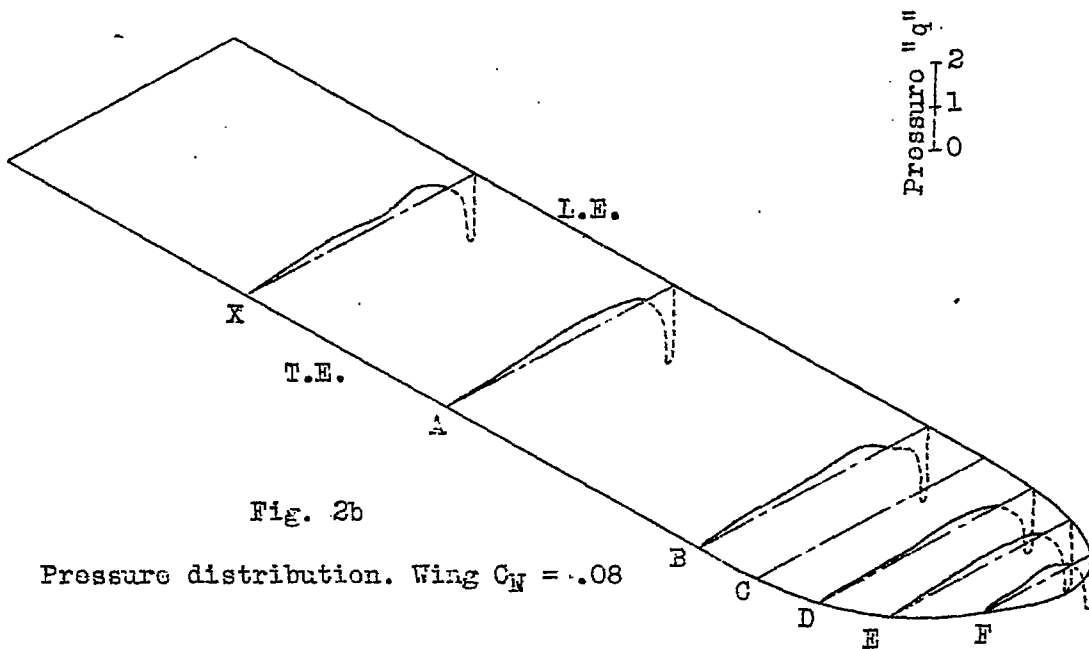
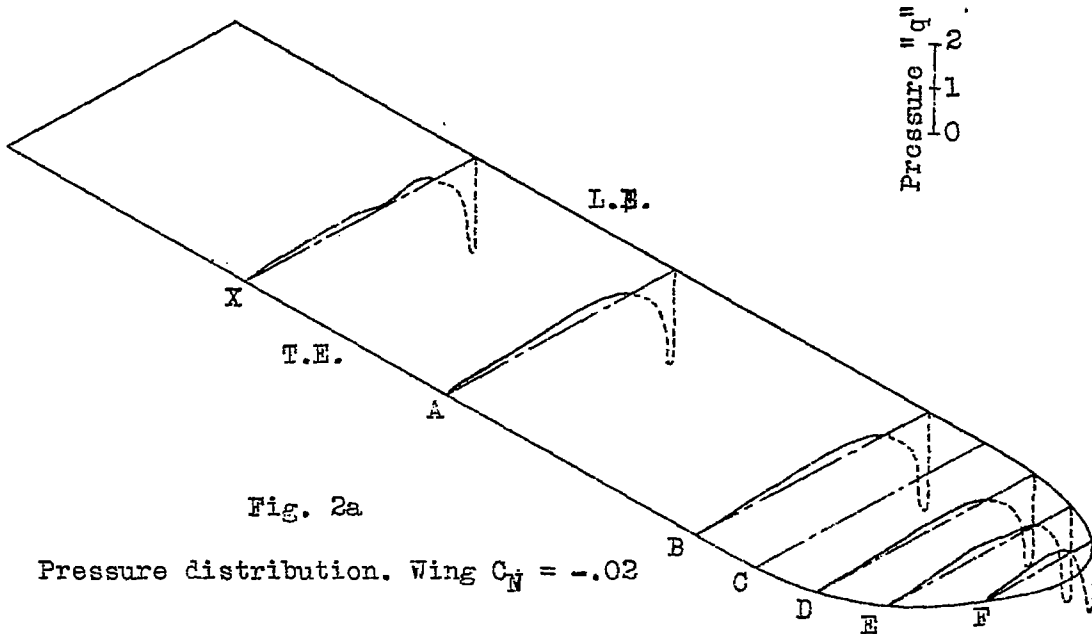
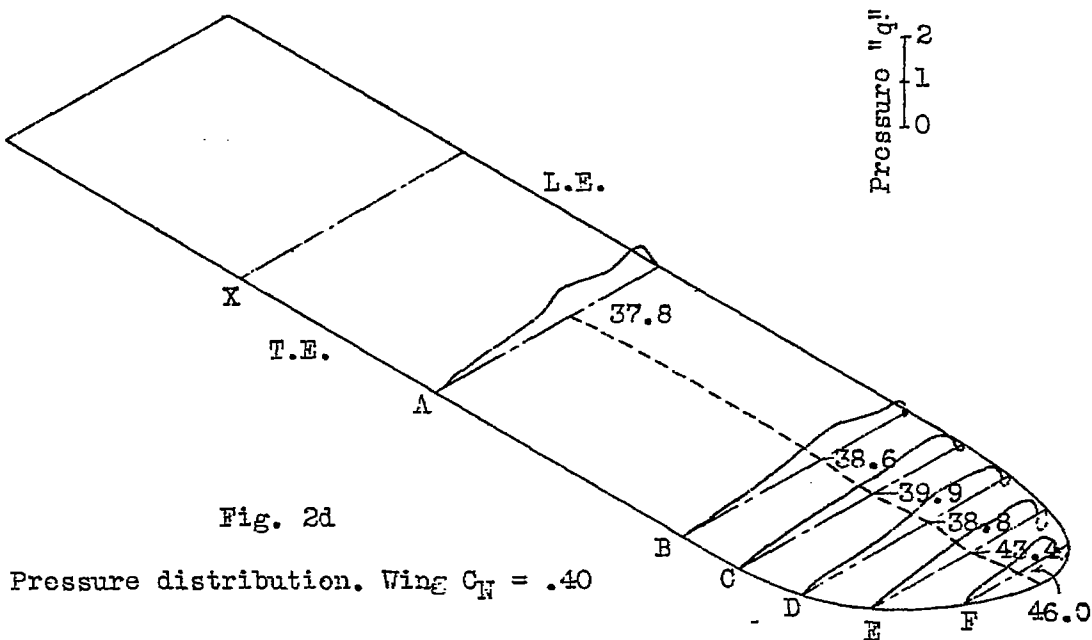
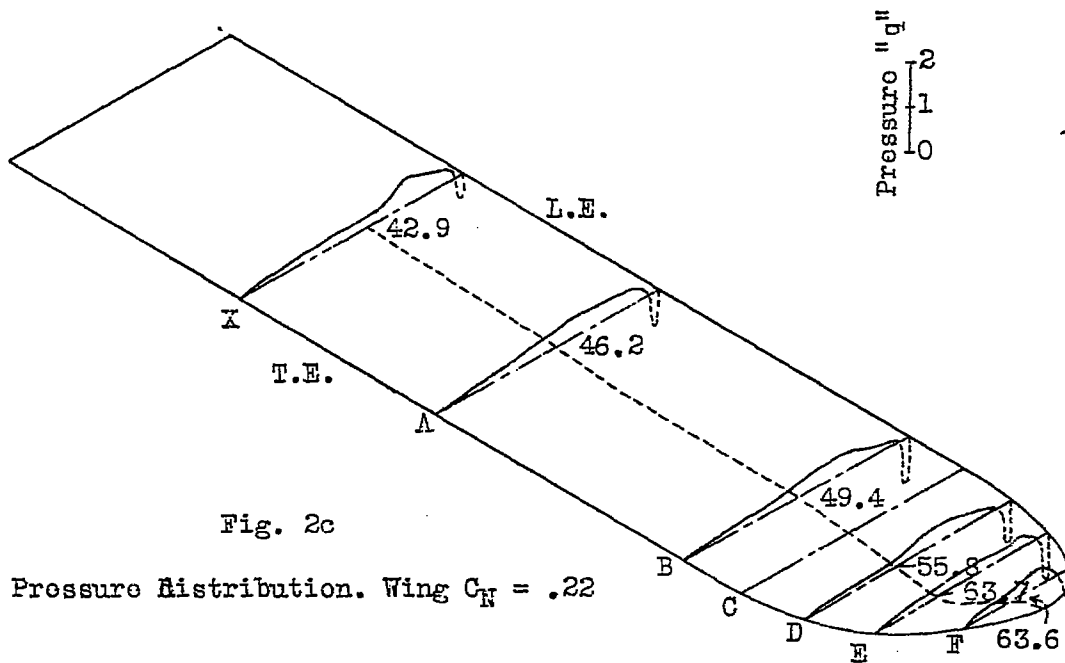
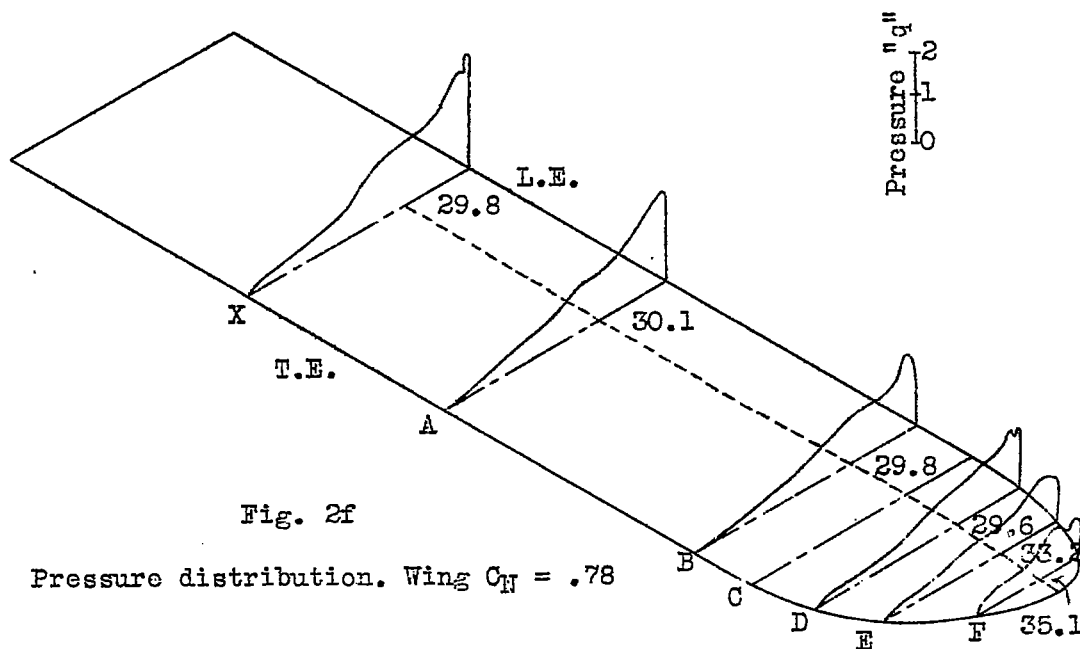
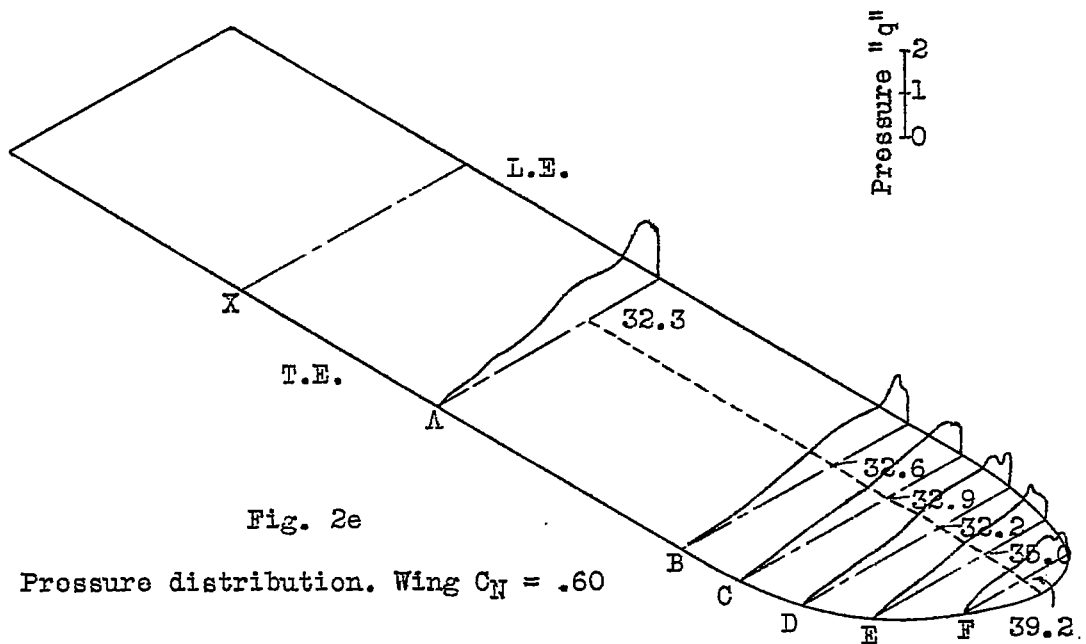
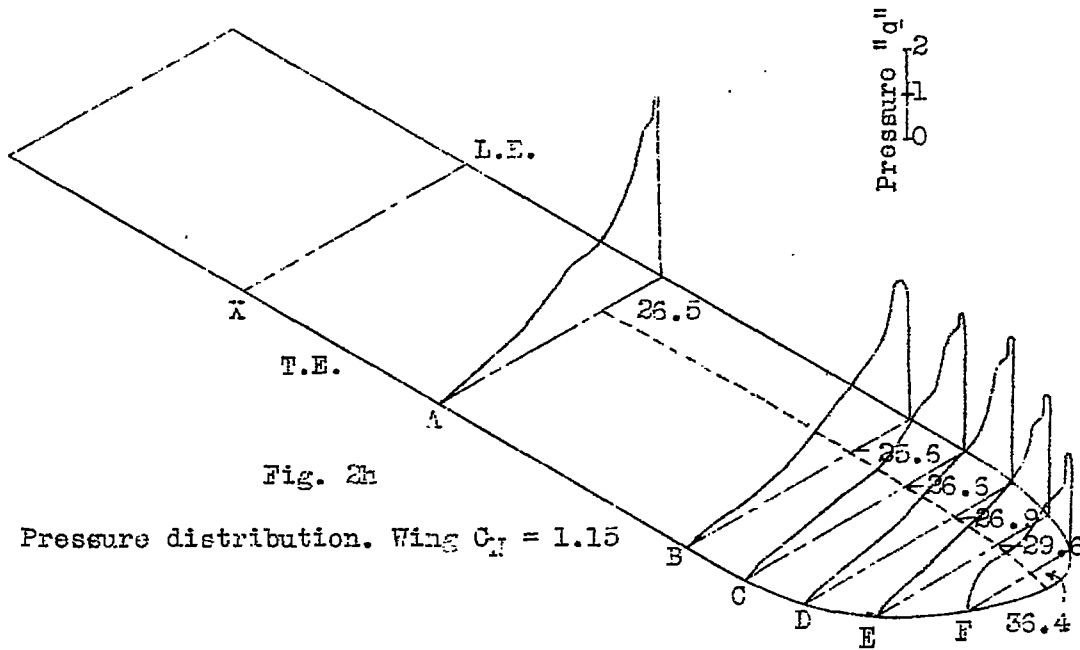
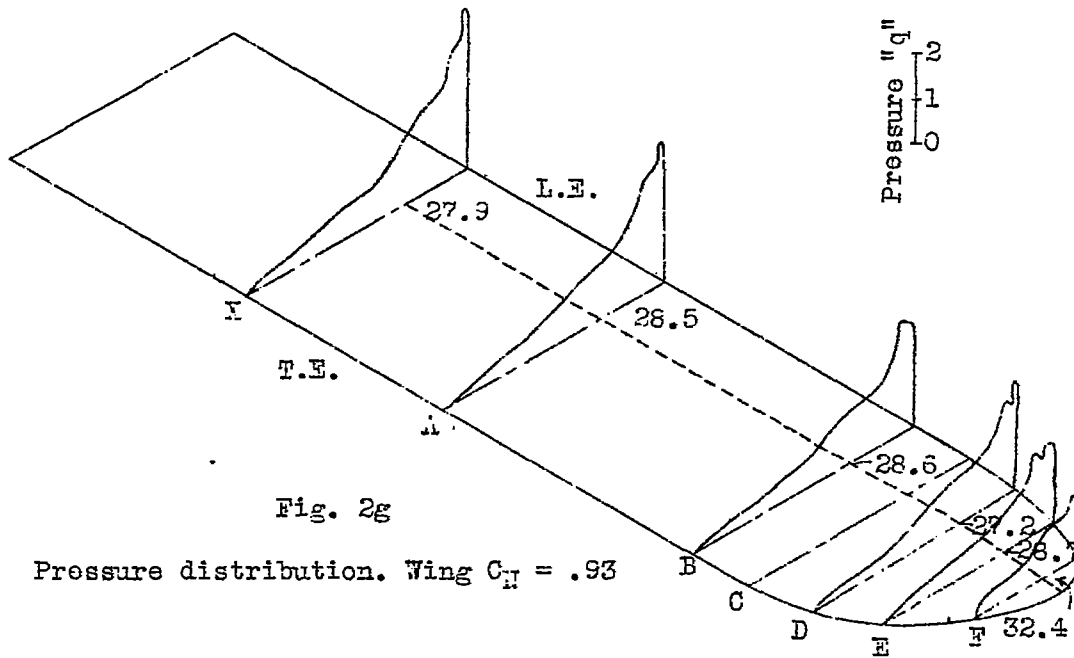

Fig. 1 M-3 wing with pressure ribs and orifice locations (modified elliptical tip with washout)









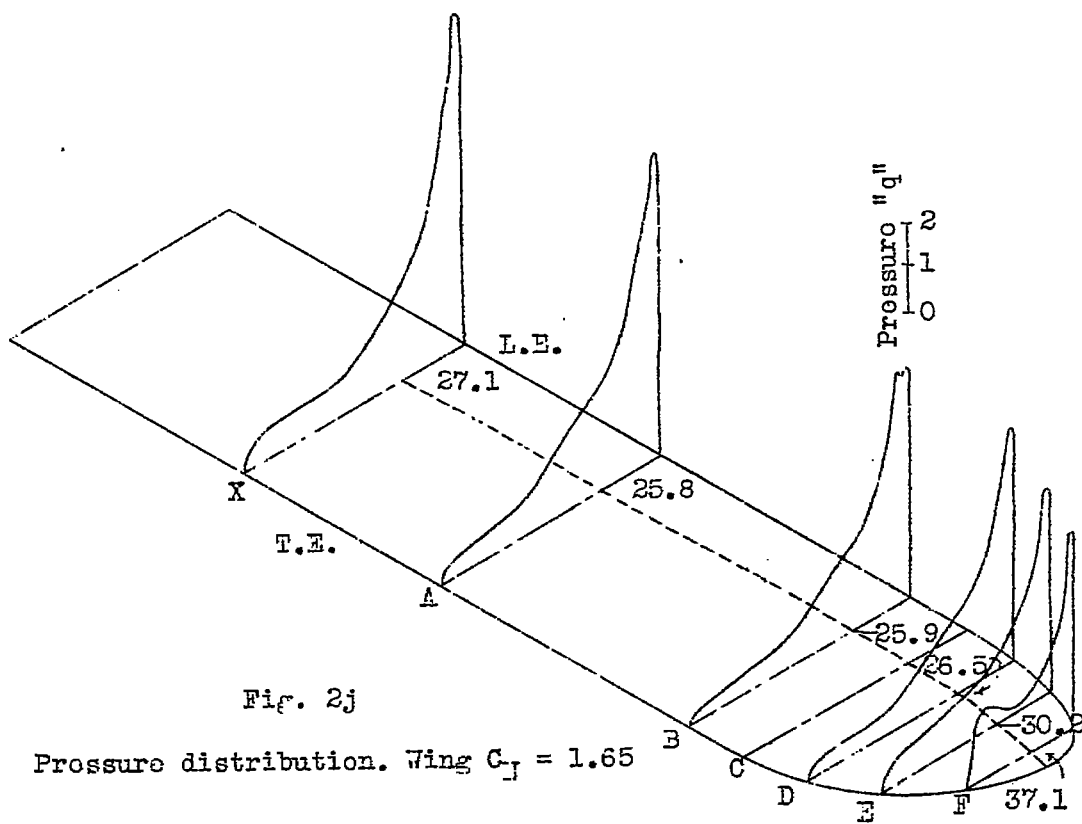
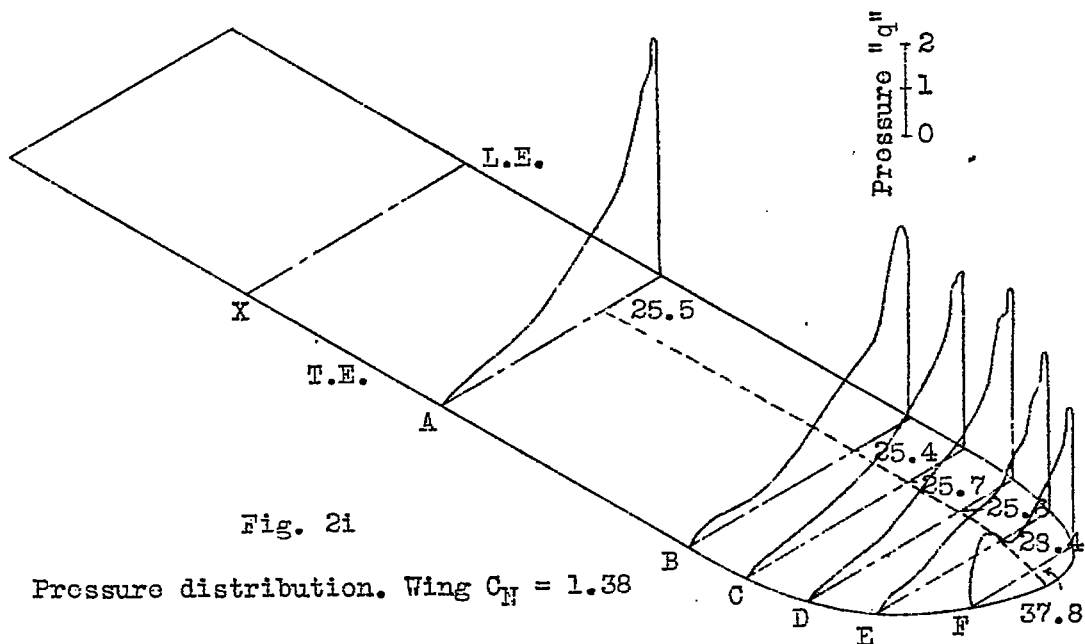

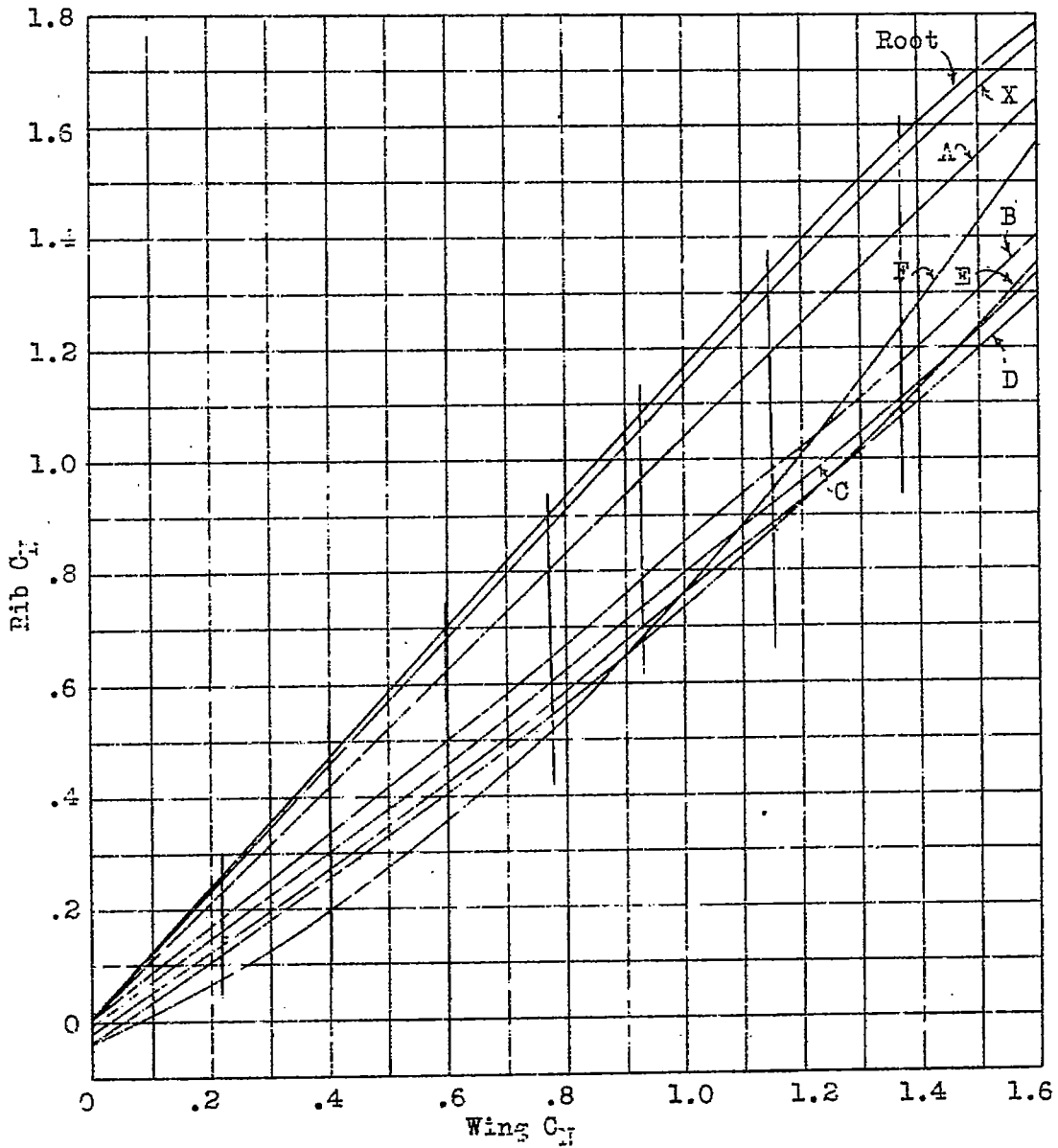

Fig. 3

Rib C_{L_i} vs. wing C_{L_i}

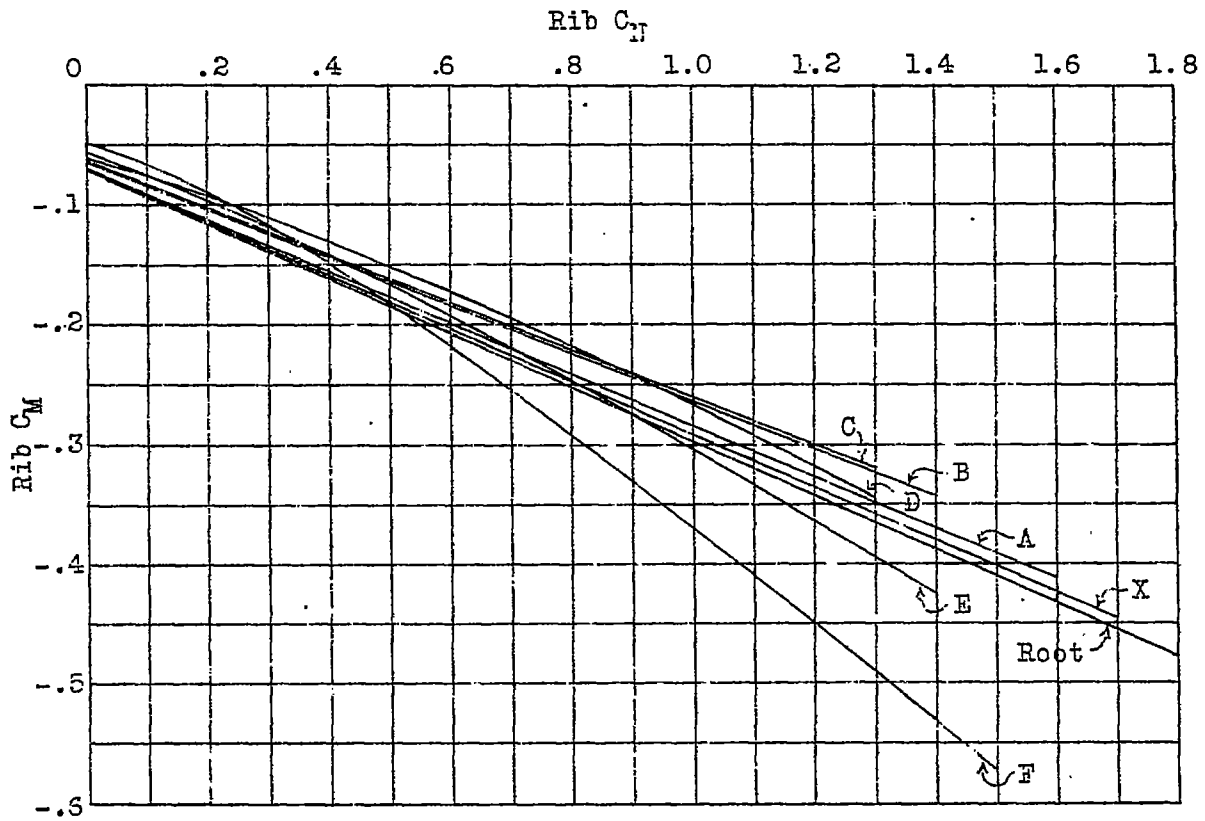

Fig. 4

Rib C_M vs. rib C_N