

1935 FEB 27

To: *Library, L. M. A. 1*

TECHNICAL NOTES

NATIONAL ADVISORY COMMITTEE FOR AERONAUTICS

No. 518

PERFORMANCE TESTS OF A SINGLE-CYLINDER
COMPRESSION-IGNITION ENGINE WITH A DISPLACER PISTON

By C. S. Moore and H. H. Foster
Langley Memorial Aeronautical Laboratory

To be returned to
the Library
National Aeronautical
Laboratory.

Washington
February 1935



3 1176 01433 6508

NATIONAL ADVISORY COMMITTEE FOR AERONAUTICS

TECHNICAL NOTE NO. 518

PERFORMANCE TESTS OF A SINGLE-CYLINDER
COMPRESSION-IGNITION ENGINE WITH A DISPLACER PISTON

By C. S. Moore and H. H. Foster

SUMMARY

Engine performance was investigated using a rectangular displacer on the piston crown to cause a forced air flow in a vertical-disk combustion chamber of a single-cylinder, 4-stroke-cycle compression-ignition engine. The optimum air-flow area was determined first with the area concentrated at one end of the displacer and then with the area equally divided between two passages, one at each end of the displacer. Best performance was obtained with the two-passage air flow arranged to give a calculated maximum air-flow speed of 8 times the linear crank-pin speed. With the same fuel-spray formation as used without the air flow, the maximum clear exhaust brake mean effective pressure at 1,500 r.p.m. was increased from 90 to 115 pounds per square inch and the corresponding fuel consumption reduced from 0.46 to 0.43 pound per brake horsepower-hour. At 1,200 r.p.m., a maximum clear exhaust brake mean effective pressure of 120 pounds per square inch was obtained at a fuel consumption of 0.42 pound per brake horsepower-hour. At higher specific fuel consumptions the brake mean effective pressure was still increasing rapidly.

INTRODUCTION

Until recently the investigations of the National Advisory Committee for Aeronautics for the development of the 4-stroke-cycle compression-ignition engine for aircraft use have been conducted on engines of the prechamber and quiescent-chamber types. (See references 1 and 2.) The prechamber depends upon high-velocity forced air flow to obtain the necessary mixing of the fuel and air. The quiescent chamber has comparatively no effective air flow at the time of injection of the fuel and must therefore

depend almost entirely upon the number, size, and direction of the fuel sprays used to obtain the required mixing of fuel and air. Each type possesses certain attractive characteristics; the prechamber has high-velocity air flow, an important aid to good fuel and air mixing; the quiescent chamber has good scavenging, easy starting, and low mechanical losses.

It was believed that these attractive characteristics could be combined in one combustion chamber by the proper application of the displacer-piston principle. (See references 3, 4, and 5.) The restricting passage formed by the displacer and the walls of the combustion chamber would exist for only a fractional part of the stroke and produce a substantial and well-timed air flow with a minimum of pumping losses. It was believed that if the combustion chamber were compact and of such shape as to conserve the air flow, the displacer type offered possibilities for obtaining performance superior to that of either the prechamber or quiescent-combustion chamber. As the quiescent-combustion chamber of reference 2 (N.A.C.A. cylinder-head design no. 4) with a displacer piston seemed capable of filling the requirements fairly well, the engine-performance possibilities were investigated.

The work presented in this report is the result of an investigation of the effect of restricting passage area on the motoring and general performance characteristics of the engine. Tests were made for two series of passages, first with the passage at one end of the rectangular displacer, and second with two equal passages, one at each end of the displacer.

This work was done during the first half of 1934 in the engine-research laboratory at Langley Field, Va.

AIR-FLOW ANALYSIS

Before starting the displacer investigation it was desired to know the relationship between passage area and resulting forced air-flow speeds at different crank positions of the compression stroke of the 5-inch bore by 7-inch stroke test engine. Such a displacer height was arbitrarily chosen that the displacer would enter the throat at 42° before top center. This height trapped 22.0 cubic

inches of air below the throat, which started a throttled flow into 10.8 cubic inches of air above the displacer. Air-flow speeds for a series of passage sizes were calculated using the following method:

$$V = (A - A_d) D + V_m + V_c$$

in which V is the total volume of air at any crank angle θ .

A_d is the displacer area and, in this analysis, is treated as zero except when the displacer is in the throat.

A is the piston area including A_d .

V_m is the volume in the mechanical clearance.

V_c is the volume in and above the throat at any crank angle θ .

D is the linear piston displacement from top center at any crank angle θ .

and
$$D = L + R - \sqrt{L^2 - R^2 \sin^2 \theta} - R \cos \theta$$

where R is one half the engine stroke

and L is the length of the connecting rod.

The rate of change of displacement with respect to θ is:

$$\begin{aligned} \frac{dD}{d\theta} &= \frac{d}{d\theta} (L + R - \sqrt{L^2 - R^2 \sin^2 \theta} - R \cos \theta) \\ &= R \sin \theta \left(1 + \frac{\cos \theta}{\sqrt{\left(\frac{L}{R}\right)^2 - \sin^2 \theta}} \right) \end{aligned}$$

where $\frac{dD}{d\theta}$ is in unit length per radian.

It is assumed that when there is a change in air volume $\Delta V_p + \Delta V_d$ (fig. 1), ΔV_p will be transmitted to V_c according to the ratio $\frac{V_c}{V}$ and that ΔV_d will be transmitted to $V - V_c$ according to the ratio $\frac{V - V_c}{V}$. The rate of volume inflow to V_c is, therefore,

$$\frac{V_c}{V} (A - A_d) \frac{dD}{d\theta} - \left(\frac{V - V_c}{V} \right) A_d \frac{dD}{d\theta}$$

Collecting terms, this expression becomes

$$\left(\frac{V_c}{V} A - A_d \right) \frac{dD}{d\theta}$$

The linear speed S of inflow through the passage is the volume speed divided by the passage area a (included in the passage area a is the area of all clearances between the displacer and the throat).

$$S = \frac{1}{a} \left(\frac{V_c}{V} A - A_d \right) \frac{dD}{d\theta}$$

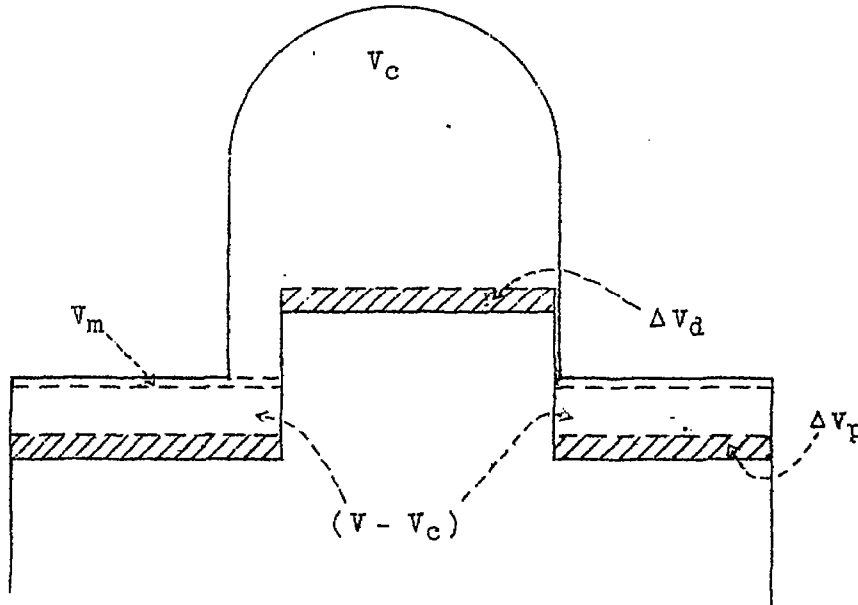

Figure 1. Diagrammatic representation of the displacer combustion chamber.

The curves a, b, c, and d of figure 2 are the calculated air-flow speeds through displacer passages of different areas during the compression stroke for an engine speed of 1,500 r.p.m. Curve e shows the relatively low air-flow speeds obtained through the large throat if the displacer is not used. Before the 50° position the flow area (throat area) is the same for each of the curves a, b, c, d, and e. The cause of the separation of the curves before this point is the variable value of $\frac{V_c}{V}$. The curve f is the calculated air-flow speed through the connecting passage of a prechamber type of engine of equivalent compression ratio with a connecting-passage area selected to give the same maximum air-flow speed as that of curve a. An analysis of these curves from considerations of energy and pumping losses shows that more energy would be required to generate the air flow of curve f than that of curve a because the prechamber passage restriction exists throughout the entire compression stroke; whereas the displacer passage restriction exists for only a small part of the compression stroke. There should be little pumping loss at the end of the exhaust and beginning of the intake strokes because the gas pressures are low and again the restriction occurs only during a small part of the strokes.

Furthermore, the air flow of the displacer curve a is more usefully phased than that of the prechamber curve f, because there is no need for flow early in the compression stroke and much need for flow during the injection period, which starts near the end of the compression stroke. This forced air flow, occurring late in the compression stroke, may be used directly to distribute fuel or it may be conserved by properly shaping the combustion chamber to form residual air flow to persist after top center when the forced flow has ceased.

APPARATUS AND METHODS

Figure 3 shows an improvised displacer piston with the cylinder head that was formerly used with a flat-top piston as a quiescent chamber. (See reference 2.) As shown, the first-design formed a single passage at one end of the displacer, all other sides having only mechanical clearance with the walls of the combustion-chamber throat. This arrangement was designated the "single-passage displacer."

Later, a similar passage was formed at the opposite end of the displacer (fig. 6) and this arrangement was designated the "double-passage displacer." In order to insure rapid change of flow area as the displacer entered the throat, a new throat orifice with vertical sides was substituted for the one with flared sides previously used with the quiescent chamber. The width of the throat orifice was held constant at $7/8$ inch for all displacer passages; the other passage dimension, designated passage width, was varied by altering the length of the displacer. Tests were conducted in which the width of the single passage was increased from $3/8$ to $3/4$ inch by $1/16$ -inch increments, and the widths of the double passage from $1/32$ to $1/2$ inch were increased by smaller increments.

For each passage size, motoring and power data were obtained over a speed range from 900 to 1,800 r.p.m. Data were also obtained for each of the injection-valve positions. Brief tests were also made with a displacer altered to provide, first, a single passage along one side and, later, two equal side passages. The engine performance was so much inferior to that with the end passages that the results have been omitted. In general, the test procedure for each passage size was the same, except for the very small flow areas in which the restricting action was sufficiently severe to cause damage to the displacer. In these instances, the duration of the tests at rated speed and load was limited to the time required to record the data. Later tests at continuous operation using a Y-alloy piston with integral displacer showed, however, that the accuracy of the data was not impaired.

In order to obtain an indication of the relative intensity of the air flow as the passage sizes were changed, brass fins of uniform size but of variable thickness were fixed alternately in each injection-valve location so that the air stream would impinge on the flat side of the fin and bend it. The amount of angular bend was taken as an indication of the relative air-flow intensity.

During all tests with both the quiescent and displacer chambers the same operator judged the operating characteristics, such as combustion sound, idling, and ease of starting. The exhaust gases were observed through a peephole located in the exhaust pipe about 11 inches from the exhaust-valve port. The limit of the clear-exhaust range, as used in this report, was marked by the first appearance of short flashes of flame and haze at the peephole.

The test equipment and general test methods were the same as those used in the quiescent-chamber tests (references 2 and 6) except as specifically noted. In order to permit a direct comparison of the displacer engine performance with that obtained with the quiescent chamber, the same approximate values of compression ratio and maximum cylinder pressure were used. For convenience of reference the standard test conditions are listed below:

Engine	Single cylinder, 5 inches by 7 inches
Engine speed	1,500 r.p.m.
Compression ratio (at optimum passage size)	15.2 (varies from 14.8 to 15.7)
Fuel	Auto diesel fuel, 0.847 specific gravity, 41 seconds Saybolt Universal viscosity at 80° F.
Standard fuel quantity (5.8 percent excess air)	0.000325 lb./cycle (air/fuel = 15.3)
Fuel-injection period (at 1,500 r.p.m.)	24 crankshaft degrees
Fuel nozzle (optimum of quiescent-chamber series)	6 orifices in one plane, with 25° between the spray axes
Orifice diameters.	The two main orifices are 0.019; the two intermediate orifices, 0.014; and the two outside orifices, 0.008 inch
Valve-opening pressure	3,000 lb. per sq. in.
Inlet air temperature	Room temperature
Temperature and pressure corrections	None

RESULTS AND DISCUSSION

Single passage displacer.— Figure 3 shows diagrams of the single-passage combustion chamber with the optimum fuel-spray axes indicated for the top fuel-injection valve location. The arrows on the diagrams indicate the direction of the air flow in the combustion chamber as determined

by the bending of the copper fins. Owing to the circular shape of the combustion chamber, the forced air flow should become a rotational swirl of residual air flow. This air swirl should persist well into the injection period and should help distribute the fuel to the regions of air between the sprays and in the top of the chamber.

Figure 4 is a summary of the single-passage displacer test results for fuel quantities at which the exhaust ceases to be clear. For each of the injection-valve locations investigated, optimum engine performance was obtained at a definite and different air-flow passage width, the topmost location of the fuel valve giving the best performance and requiring the largest flow area with its correspondingly lower air speed. Too small an area of flow evidently results in rapid motion of the air at the circumference of the chamber but leaves the air in the central part of the chamber comparatively undisturbed. The results show that the optimum passage width for this height displacer is $5/8$ inch. The calculated maximum air-flow speed through this passage is 350 feet per second at 1,500 r.p.m. engine speed, which is equivalent to 7.6 times the linear velocity of the crankpin. The maximum performance was obtained with the top fuel-valve location and an injection nozzle that was optimum for the quiescent-chamber operation. The intermediate fuel-valve location was inferior to either the top or bottom location.

As the passage size was increased, the engine operation became smoother. The engine operation at the optimum passage size was quite similar to that of the quiescent chamber with regard to smoothness. The decrease in friction mean effective pressure (f.m.e.p.) with increase in passage size results from a decrease in pumping losses. It may be noted in figure 4 and subsequent figures that the compression pressure, measured above the restricting passage, remains fairly constant despite an increase in passage size and consequent increase in combustion-chamber volume. It is believed this condition is caused by pressure loss through the restricting passage. Prechamber results (reference 7) in which the pressures were recorded above and below the passage showed that there was a considerable pressure difference which decreased with increase in passage size.

In addition to the multiple-orifice fuel-injection nozzles that had been designed for use with the quiescent chamber, nozzles having 1, 2, and 3 orifices were tested in each injection-valve location. In general, the trend of the results was the same as that for the quiescent

chamber; that is, the spray formation that gave the best fuel distribution in the quiescent chamber gave optimum results with the displacer.

Figure 5 shows a comparison of the optimum engine performance of the quiescent chamber and the single-passage displacer. The displacer increased the brake mean effective pressure from 104 to 120 pounds per square inch and decreased the corresponding fuel consumption from 0.54 to 0.46 pound per brake horsepower-hour for operation at standard fuel quantity (air/fuel = 15.3 in both cases). The clear exhaust brake mean effective pressure was increased from 90 to 109 pounds per square inch while with the specific fuel consumption decreased from 0.46 to 0.44 pound per brake horsepower-hour. Although the use of the displacer caused a 9-percent increase in friction mean effective pressure, the net gain in brake mean effective pressure was sufficient to increase the mechanical efficiency from 76.4 to 77.4 percent. Since the compression ratio was nearly the same for both the quiescent and displacer chambers and the maximum cylinder pressure somewhat lower with the displacer, it is concluded that the improvement in performance was probably due very largely to an improvement in fuel and air mixing which permitted the fuel charge to burn more efficiently.

The air-flow passage was placed on the opposite side of the combustion chamber by rotating the piston through 180°. This arrangement changed the relative position of the flow passage and the middle and bottom injection-valve locations. In effect, two additional injection-valve locations were added and afforded a further means of investigating to what extent the air swirl persisted around the circumference of the chamber. Brass fins placed in the middle and bottom holes were bent slightly downward by the air flow, indicating that the swirl still persisted at the farthest removed valve location but with a considerably diminished intensity. Trial power tests made with the injection valve in each of these two new locations showed the general performance and engine-operating characteristics to be inferior to those obtained with the valve in the other positions.

Double-passage displacer.— Figure 6 shows outlines of the combustion chamber formed by the double-passage displacer. The probable air-flow paths are indicated for successive piston positions during the compression stroke. The outward rotations of the air flow (fig. 6c) occur before the fuel is injected but each rotation changes to inward (fig. 6d) before the start of injection which is ap-

proximately 10° before top center. It is possible that this last air flow persists as two orderly air swirls in the central part of the chamber. The action of the air flow upon the fuel sprays is probably such that the fuel distribution throughout the combustion chamber is more complete than that of the quiescent chamber, especially in the top of the chamber. The fuel-nozzle orifice sizes and directions and the relative spray lengths at piston top center are indicated in figure 6d. This fuel nozzle, one of a series designed for quiescent-chamber operations, was not only the optimum for the quiescent-chamber tests but was also the optimum for the displacer tests.

Figure 7 shows that the highest brake mean effective pressure and the lowest specific fuel consumption were obtained with $19/64$ -inch passages, which gave at 1,500 r.p.m. a calculated maximum air-flow speed of 368 feet per second or 8 times the linear speed of the crankpin. The 5-pound-per-square-inch increase in friction mean effective pressure as the passage width was decreased from $1/2$ to $19/64$ inch was more than compensated for by the increase in maximum clear exhaust brake mean effective pressure from 104 to 115 pounds per square inch. For passage widths smaller than $19/64$ inch, the increase in friction mean effective pressure accounts for part of the decrease in brake mean effective pressure, but the greatest decrease is probably due to the poorer mixing ability of the greatly reduced cross section of the air stream.

Figure 8 shows a comparison of the engine performance obtained with the quiescent chamber and with the double-passage displacer chamber under similar operating conditions. At the standard fuel quantity the brake mean effective pressure of 104 pounds per square inch has been increased to nearly 123 pounds per square inch and the corresponding fuel consumption has been decreased from 0.54 to 0.46 pound per brake horsepower-hour, by the use of the displacer. Furthermore, the maximum clear exhaust brake mean effective pressure of the quiescent chamber increased from 90 to 115 pounds per square inch, or 27.8 percent; and despite an 8.6-percent increase in friction mean effective pressure, the mechanical efficiency increased from 76.4 to 77.8 percent. Considering the improvement with respect to equivalent exhaust conditions, the use of the displacer allowed 22 percent more fuel per cycle to be burned with a 6.5-percent decrease in the specific fuel consumption. It may be noted also that the brake mean effective pressure curve of the quiescent chamber has nearly ceased to rise at the standard fuel quantity of 0.000325 pound per cycle; whereas that of the displacer is still rising steeply at that fuel quantity.

Figure 9 presents a summary of the results obtained at an engine speed of 1,200 r.p.m. The trends are the same in all respects as those at 1,500 r.p.m. except that the performance at passage sizes below the optimum falls off less rapidly. Values of brake mean effective pressure, however, are 4 to 6 pounds per square inch higher and the specific fuel consumptions correspondingly lower. This improvement at the slower speed is believed to be due to a lower friction mean effective pressure, better air charging, and a longer time available for effective combustion.

Variable-fuel-quantity curves (fig. 10) show the high performance at 1,200 r.p.m. and the reserve power beyond the clear-exhaust range as evidenced by the steep slope of the mean effective pressure curves. The curves were not peaked over because it was not desired to risk damaging the improvised displacer piston. At a fuel quantity of 0.00035 pound per cycle the brake mean effective pressure is 132 pounds per square inch and the corresponding fuel consumption, 0.46 pound per brake horsepower-hour. The maximum clear exhaust brake mean effective pressure is 120 pounds per square inch with a fuel consumption of 0.42 pound per brake horsepower-hour. At the point of minimum fuel consumption, 0.41 pound per brake horsepower-hour, the brake mean effective pressure is 108 pounds per square inch.

Figure 11 shows the results of variable-speed tests for maximum load with clear exhaust and for operation at a fuel quantity of 0.000325 pound per cycle. The injection advance angle (i.a.a.) was increased with increase in engine speed to keep the maximum cylinder pressures constant. At 1,800 r.p.m. it may be noted that there is a considerable decrease in the fuel quantity per cycle burned with a clear exhaust as compared with that at the lower speeds. The rate of burning is apparently lowered, but by what factors is not definitely known. The effect of engine speeds above 1,500 r.p.m. on engine performance will be further investigated.

For all speeds the engine performance and exhaust conditions with fuel injection from the middle and bottom valve locations were considerably inferior to those with injection from the top hole and the general performance decreased more rapidly as the passage size was increased. With the fuel valve in the middle and bottom locations, the two similar streams of air flow acted upon unlike

parts of the fuel spray to give uneven distribution and poor performance.

Particular notice was taken of the exceptionally good starting characteristic of the engine with the optimum double passages and fuel spray. With the entire engine, water, air, etc. at room temperature (about 70° F.), regular firing would begin with the first compression from a standing start.

Comparison of single- and double-passage displacer results.- There is little difference in the engine-operating characteristics for either type of displacer for the same air-flow speeds but the performance values were slightly better for the double-passage than for the single-passage combustion chamber. When considered with regard to fuel spray and air-flow relation, it is conceivable that the double-passage displacer gave the best performance because it gave a perfectly symmetrical relation of fuel spray to air flow. Both sides of the spray were acted upon by similar streams of air flow.

The shapes of the carbon formations on the piston crown were quite definite indications of the gas flow in the cylinder during the first part of the expansion stroke. Apparently, the issuing gases divide at the passage exit and form one large eddy on each side of the single-passage displacer. In the double-passage type two eddies are formed on each side of the displacer. Other investigations at this laboratory have shown this swirl in the cylinder to be ineffective in burning the cylinder air (reference 1).

Attaching the displacer to a stock piston gave a top-heavy construction and may have accentuated some of the difficulties encountered. In the single-passage tests there was evidence of the pistons being forced to the side opposite the passage; whereas with the double-passage type, rubbing was more uniform all around, indicating that two passages are better with respect to balanced gas forces on the piston. Piston-ring wear was excessive for both improvised displacers but was much less for the double-passage displacer.

After a 5-hour full-load test at 1,500 r.p.m. with a two-passage displacer that was integral with the piston, an inspection showed no sign of erosion or burning. The engine performance checked that of the improvised displacer

piston. This test and subsequent tests showed that the piston-ring wear was not excessive.

Typical indicator cards with and without air flow are shown for comparison in figures 12, 13, and 14. All indicator cards show two distinct rates-of-pressure rise, although this characteristic is much more pronounced in the displacer combustion-chamber cards than in the quiescent combustion-chamber cards. The maximum rate-of-pressure rise is about the same for all three, 50 pounds per square inch per degree at 1,500 r.p.m. The principal difference from the quiescent combustion-chamber cards is the characteristic early breakaway of both the displacer-power cards, believed to be due to the residual heat in the displacer.

Further work is planned to determine the optimum displacer height, the optimum fuel-spray formation, and the engine performance for boosted and scavenged operation with the optimum displacer and fuel spray.

CONCLUSIONS

1. Air flow generated by the use of a displacer piston can be used to increase the power output and to decrease the specific fuel consumption of a high-speed 4-stroke-cycle compression-ignition engine having a vertical disk form of combustion chamber.
2. The optimum maximum calculated air-flow speed was 7.5 times the linear speed of the crankpin for the single-passage displacer and 8 times for the double-passage displacer.
3. The double-passage displacer was slightly superior to the single-passage displacer with respect to engine performance and service.
4. Erosion or burning of the displacer or piston crown will not be encountered if the displacer is made integral with the piston.
5. The optimum fuel-valve nozzle developed for the quiescent-combustion chamber was also the optimum of the

some development series for the double-passage displacer combustion chamber.

Langley Memorial Aeronautical Laboratory,
National Advisory Committee for Aeronautics,
Langley Field, Va., January 22, 1935.

REFERENCES

1. Moore, C. S., and Collins, J. H., Jr.: Effect of Combustion-Chamber Shape on the Performance of a Prechamber Compression-Ignition Engine. T.N. No. 514, N.A.C.A., 1934.
2. Spanogle, J. A., and Foster, H. H.: Basic Requirements of Fuel-Injection Nozzles for Quiescent Combustion Chambers. T.N. No. 382, N.A.C.A., 1931.
3. Buchner, Dr.: The Fundamental Principles of High-Speed Semi-Diesel Engines. T.M. No. 358, F.A.C.A., 1926.
4. The Modern Diesel. Second Edition, Iliffe and Sons Limited, Dorset House, Stamford St., London, 1933.
5. Heldt, P. M.: High-Speed Diesel Engines. First Edition, P. M. Heldt, Philadelphia, 1932.
6. Spanogle, J. A., and Foster, H. H.: Performance of a High-Speed Compression-Ignition Engine Using Multiple Orifice Fuel Injection Nozzles. T.N. No. 344, N.A.C.A., 1930.
7. Moore, C. S., and Collins, J. H., Jr.: Effect of Connecting-Passage Diameter on the Performance of a Compression-Ignition Engine with a Precombustion Chamber. T.N. No. 436, N.A.C.A., 1932.

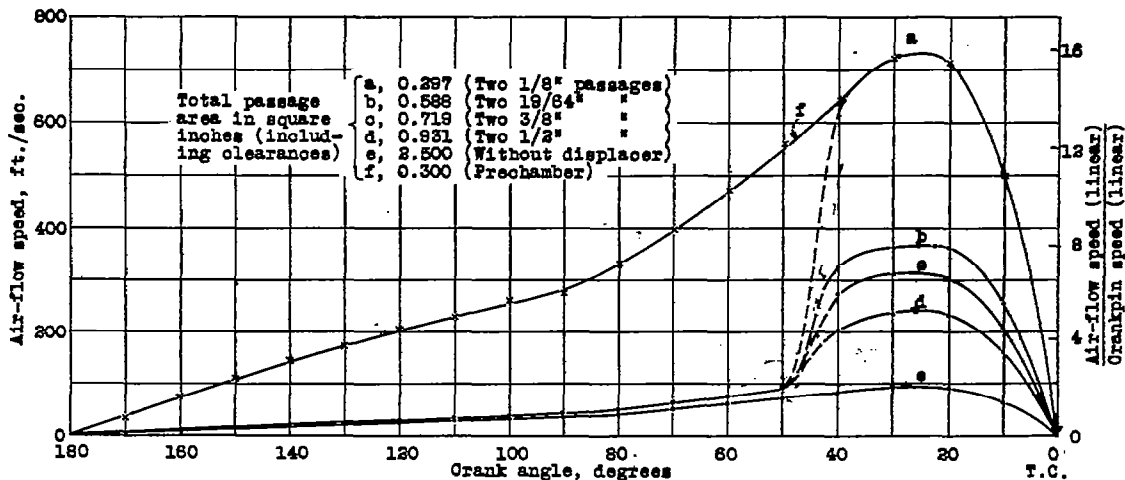

Figure 2.- Relationship of air-flow speed to crank position and passage area during the compression stroke of a 5 by 7 engine with a 12-inch connecting rod. (Engine speed, 1,500 r.p.m.; displacer height, 1 3/16 inches).

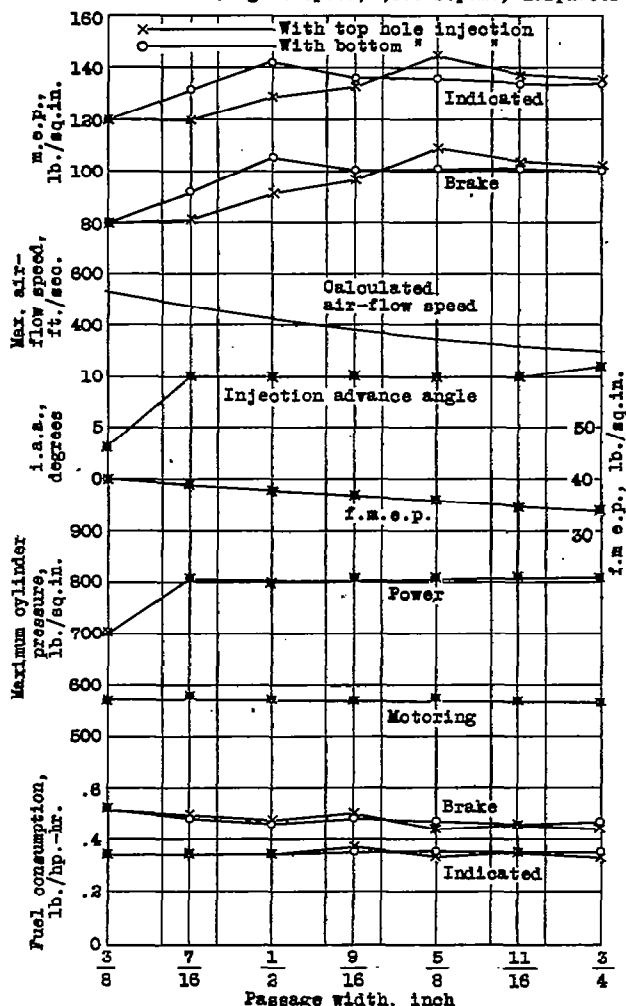

Figure 4.- Effect of passage width and injection-valve location on clear-exhaust engine performance. (Single-passage displacer, 1,500 r.p.m.).

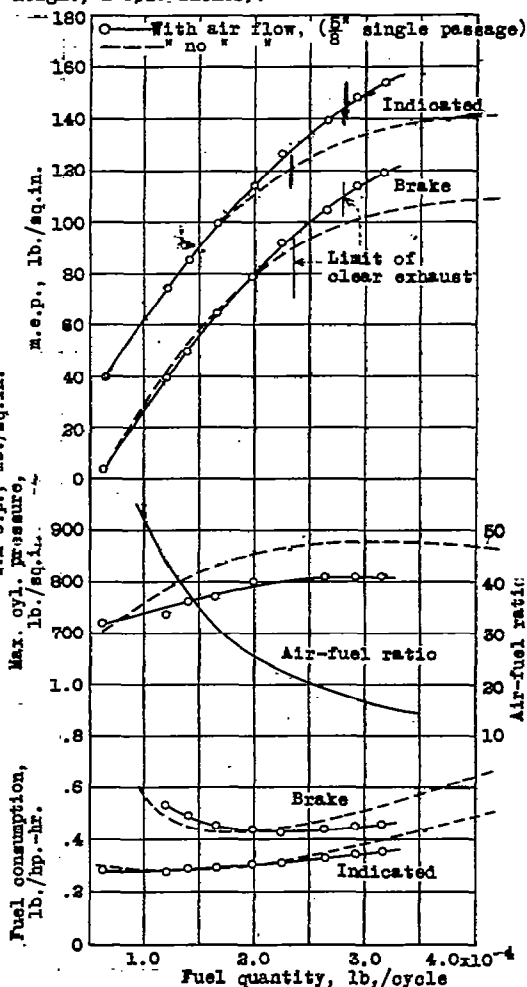

Figure 5.- Comparison of engine performance with and without air flow. (Single-passage displacer, 1,500 r.p.m.).

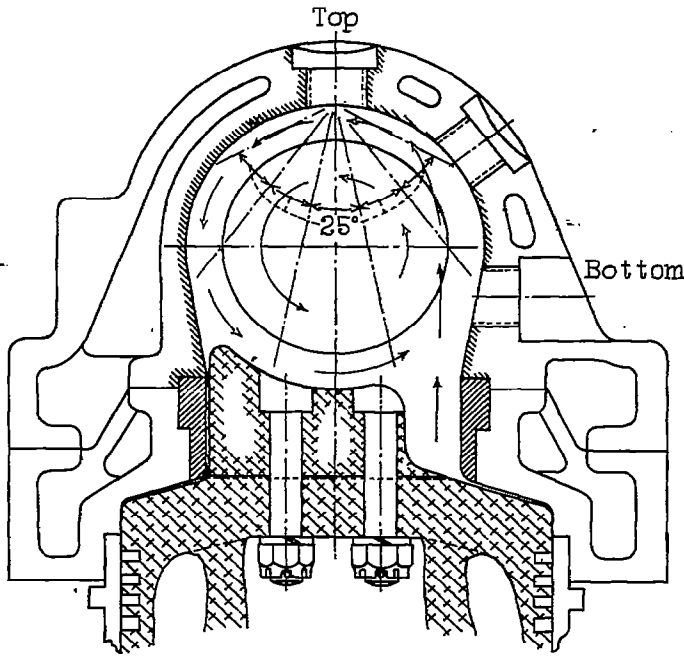
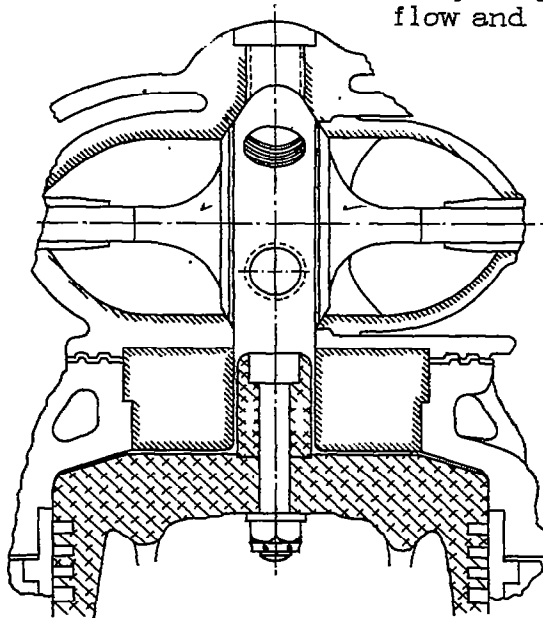

Figure 3. (Side)



(End)

Figure 3.- Single-passage displacer combustion chamber.

a, 42° B.T.C.
Displacer
enters
throat.

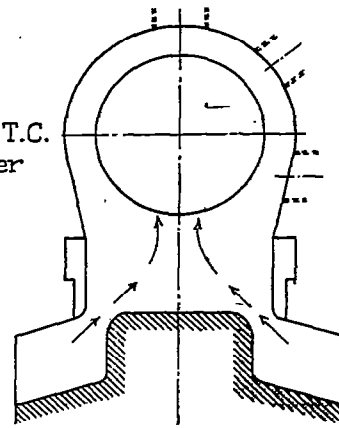

b, 35° B.T.C.

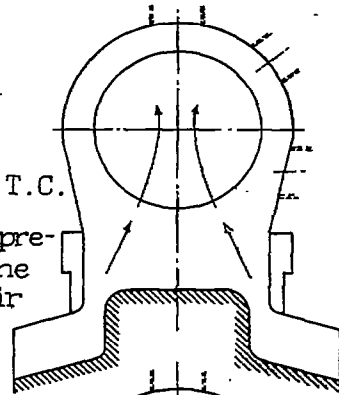
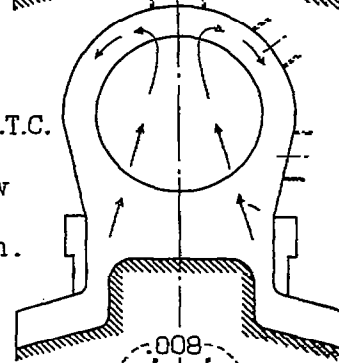
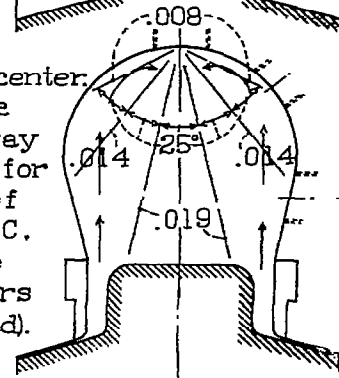

Figure 6.-Diagrammatic representation of the two-passage displacer air flow and fuel sprays.

c, 30° B.T.C.
Maximum
air-flow
speed
position.



d, Top center.
Relative
fuel-spray
lengths for
i.e.a. of
10° B.T.C.
(Orifice
diameters
indicated).



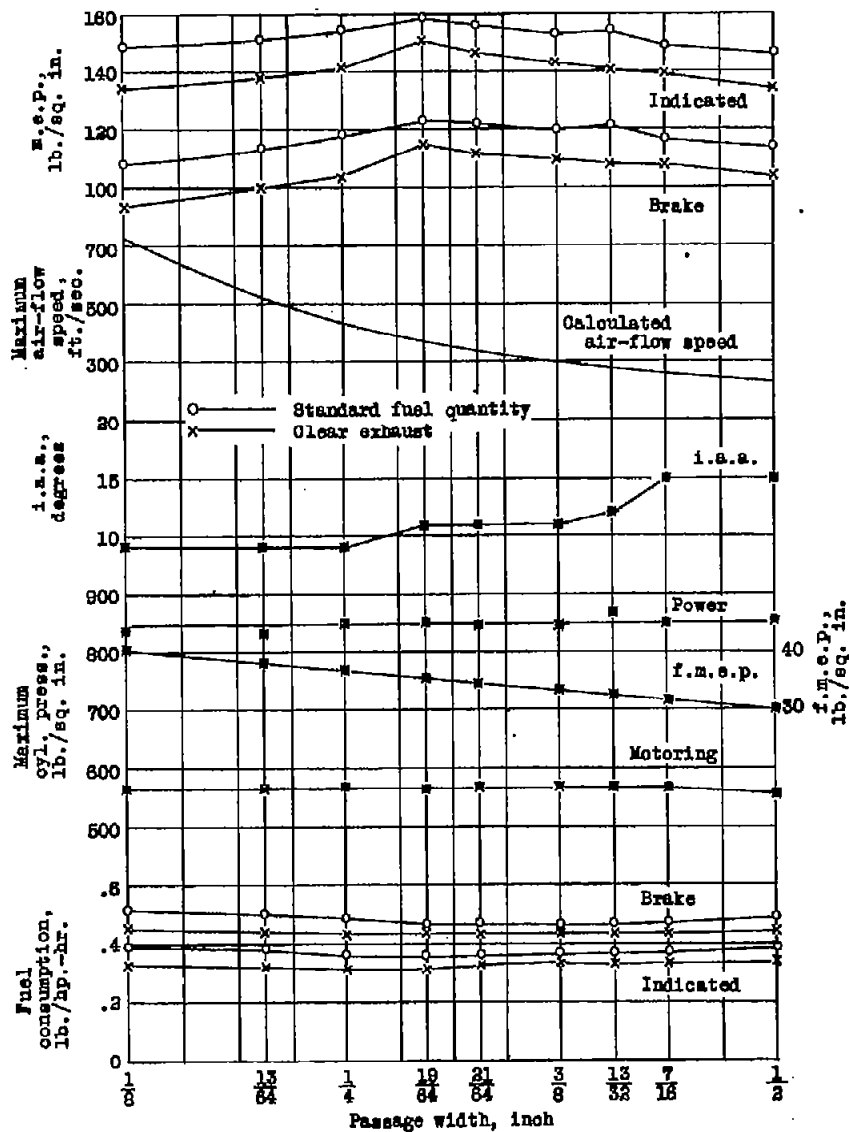

Figure 7.- Effect of passage size on engine performance.
(double-passage displacer 1,500 r.p.m.)

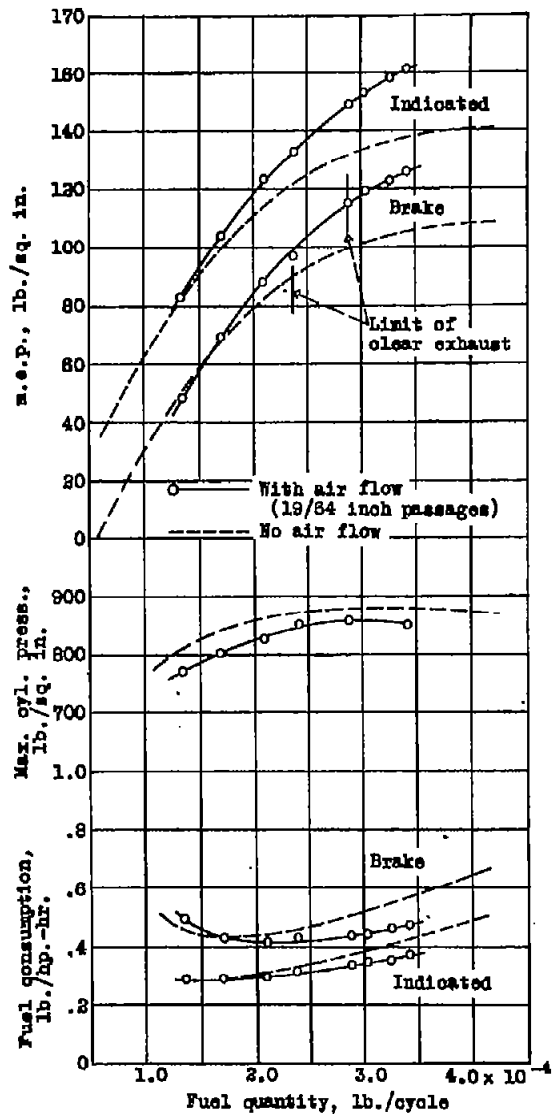

Figure 8.- Comparison of engine performance with
and without air flow.
(double-passage displacer 1,500 r.p.m.)

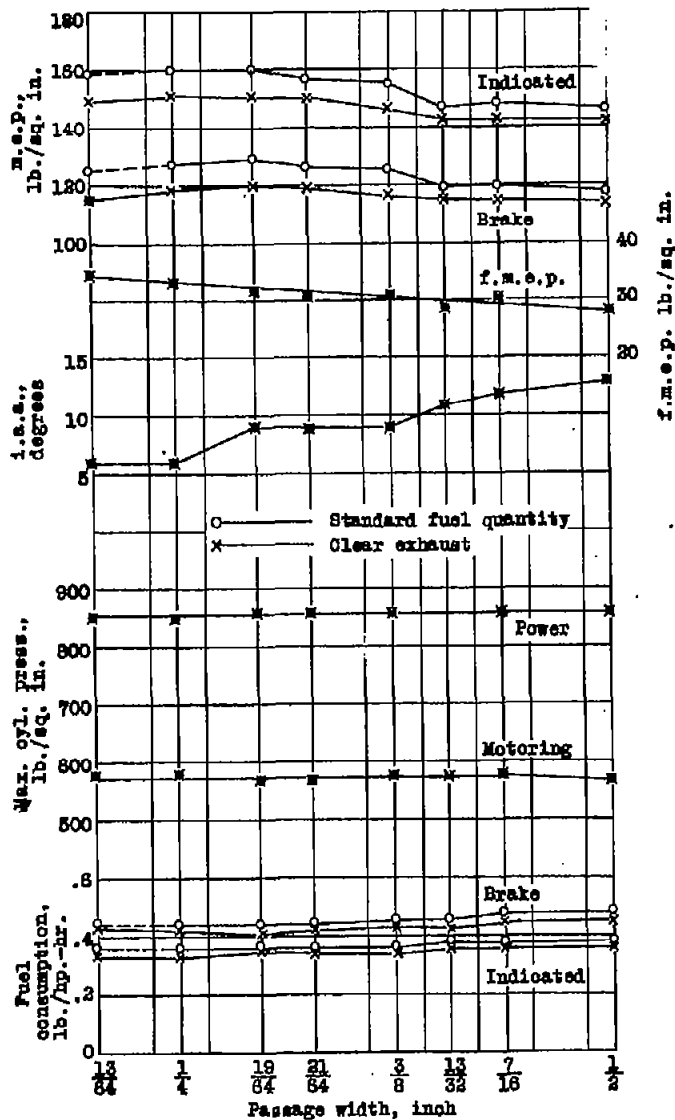

Figure 9.- Effect of passage size on engine performance, (double-passage displacer, 1,200 r.p.m.)

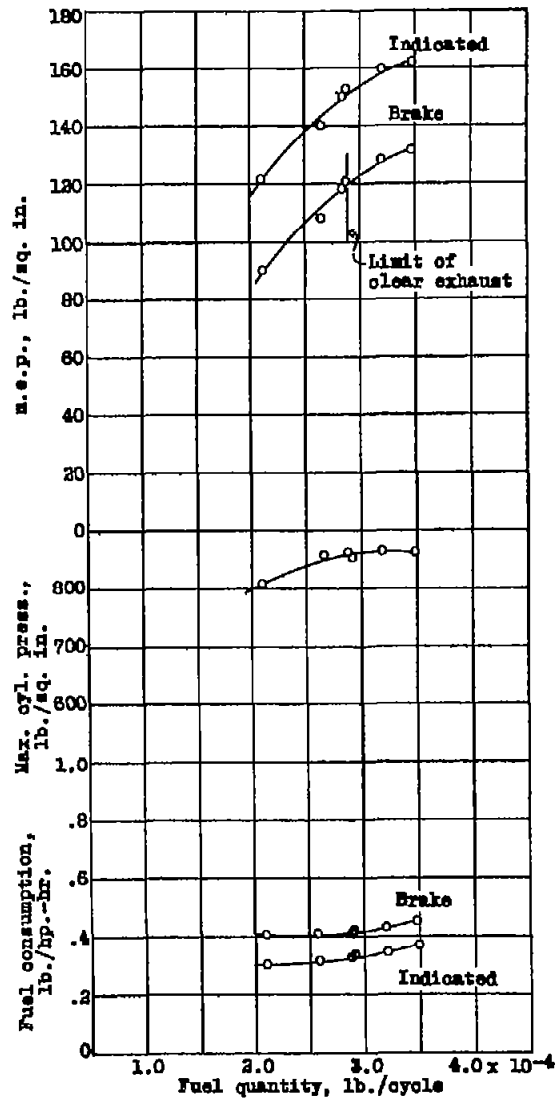

Figure 10.- Effect of fuel quantity on engine performance, (19/64 inch double-passage displacer, 1,200 r.p.m.)

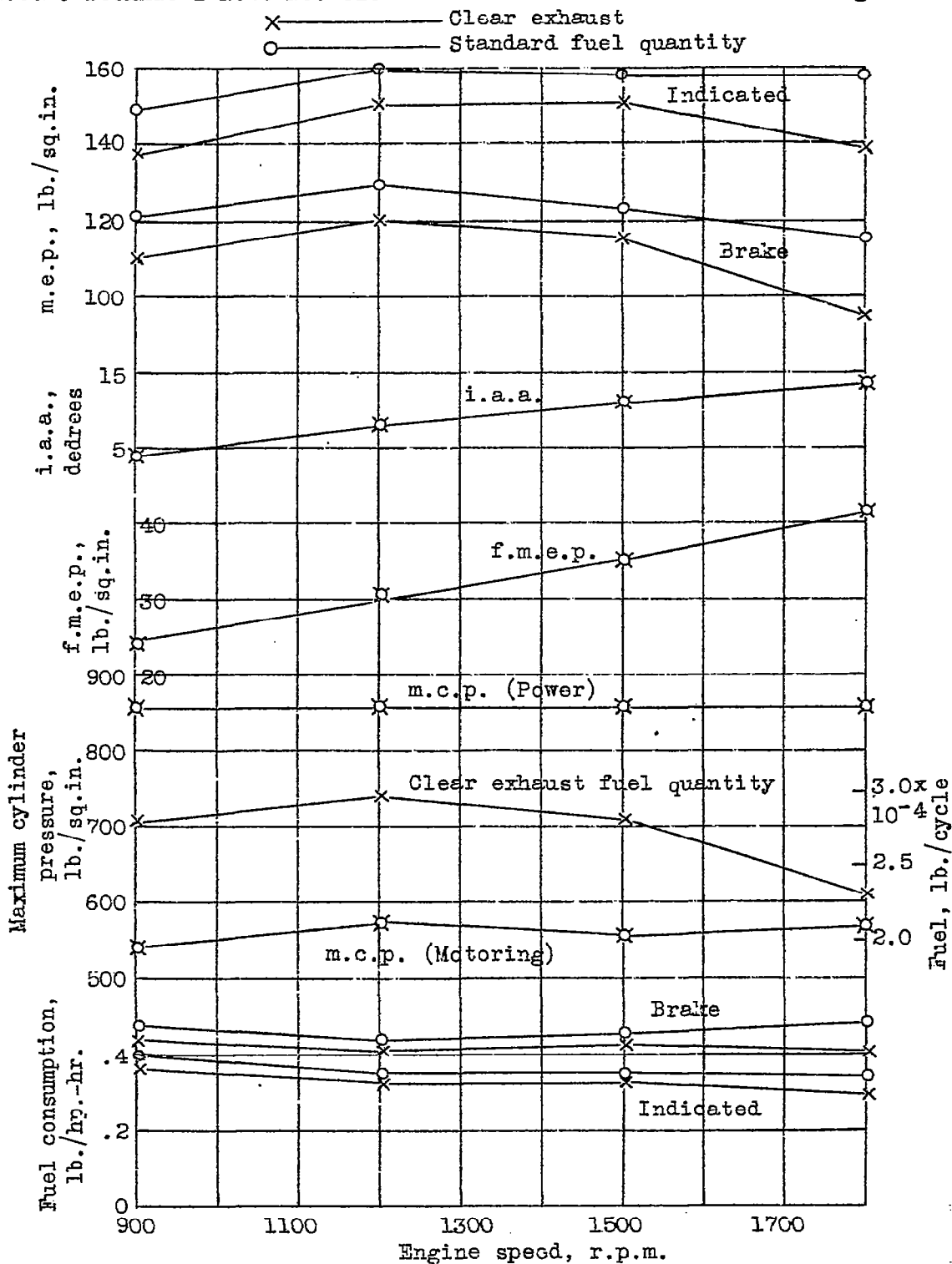

Figure 11.- Effect of engine speed on performance. (19/64 inch double-passage displacer).

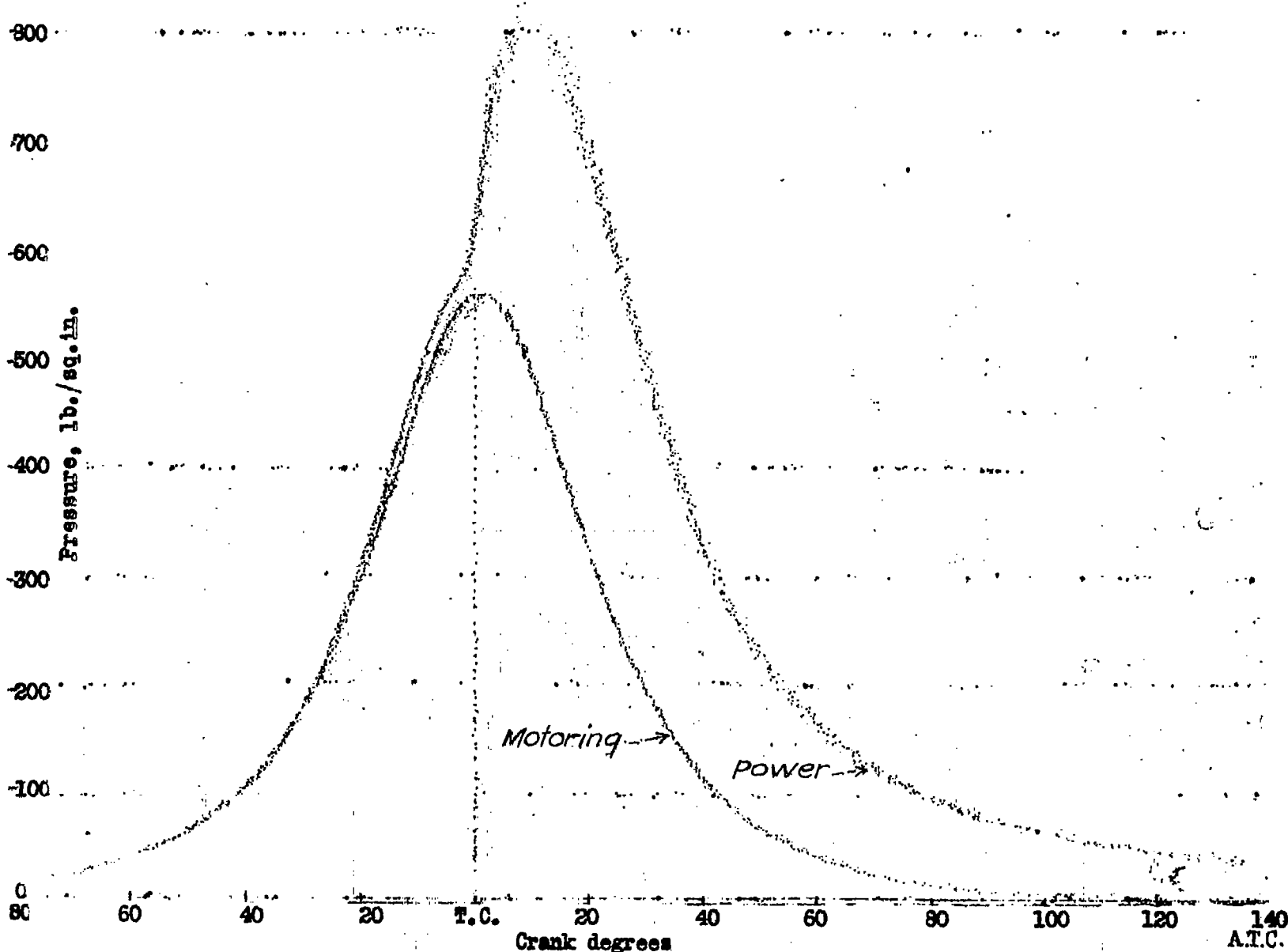

Figure 12.- Typical power-motoring indicator card of the single-passage displacer.

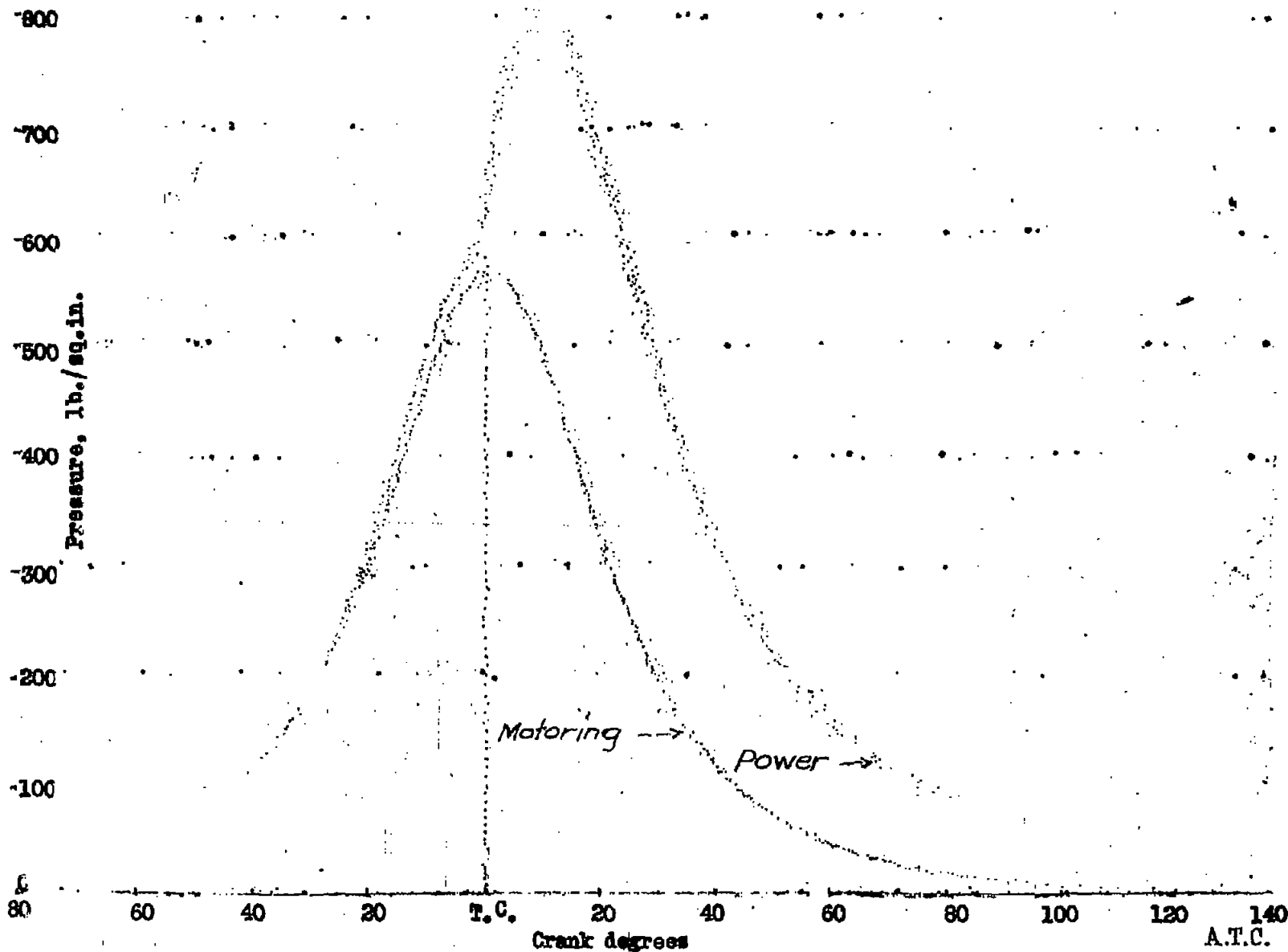

FIG. 13

Figure 13.- Typical power-motoring indicator card of the double-passage displacer.

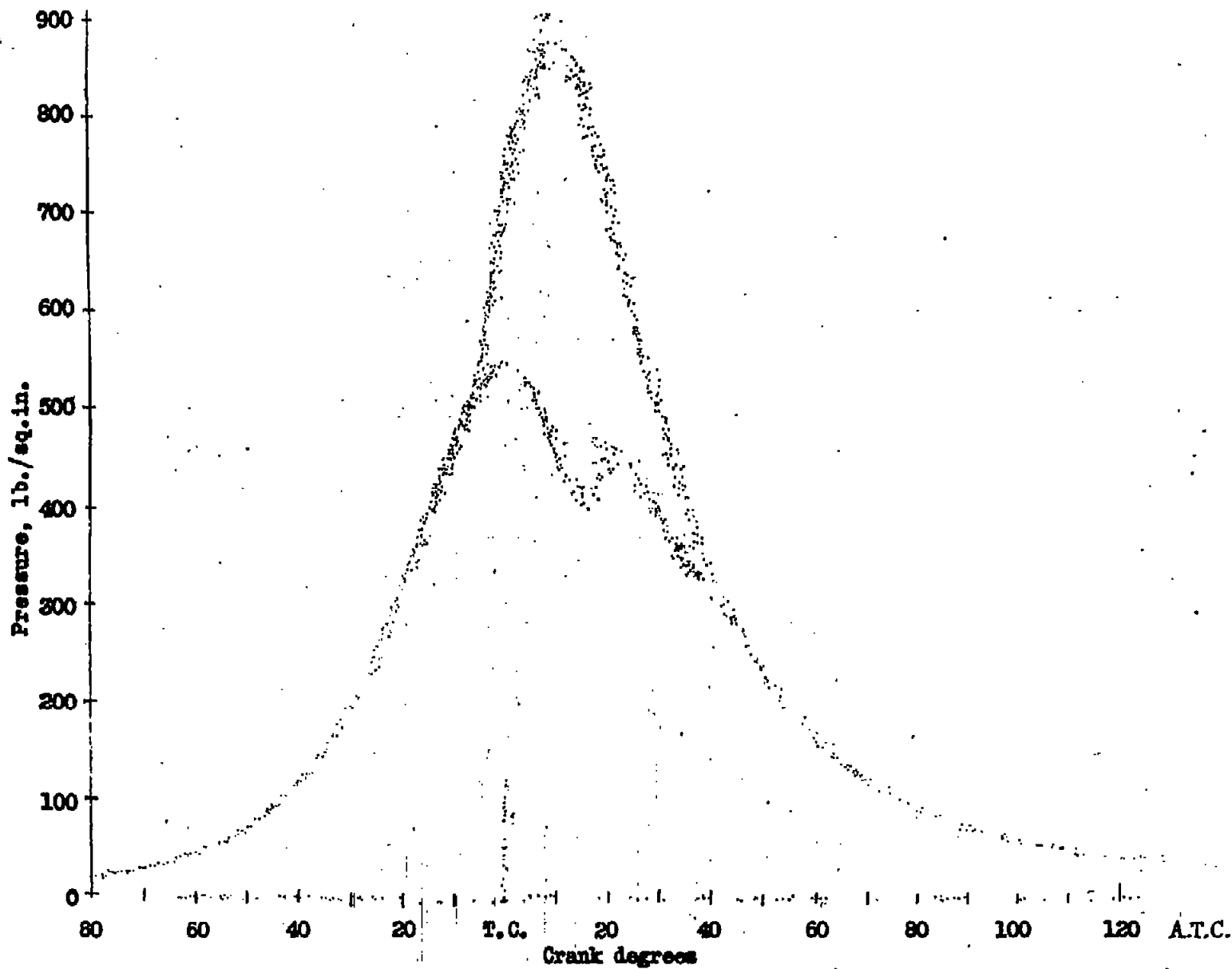

Figure 14.- Typical quiescent combustion chamber indicator card. (Optimum and retarded i.a.a.).