

Y3.N 21/5:6/608

GOVT. DOC.

NG08

for Aeronautics
MAILED
AUG 28 1937

To: Stanford Public Library

TECHNICAL NOTES
NATIONAL ADVISORY COMMITTEE FOR AERONAUTICS

No. 608

FREE-SPINNING WIND-TUNNEL TESTS OF A LOW-WING MONOPLANE
WITH SYSTEMATIC CHANGES IN WINGS AND TAILS

I. BASIC LOADING CONDITION

By Oscar Seidman and A. I. Neihouse
Langley Memorial Aeronautical Laboratory

Washington
August 1937

BUSINESS, SCIENCE
& TECHNOLOGY DEPT.

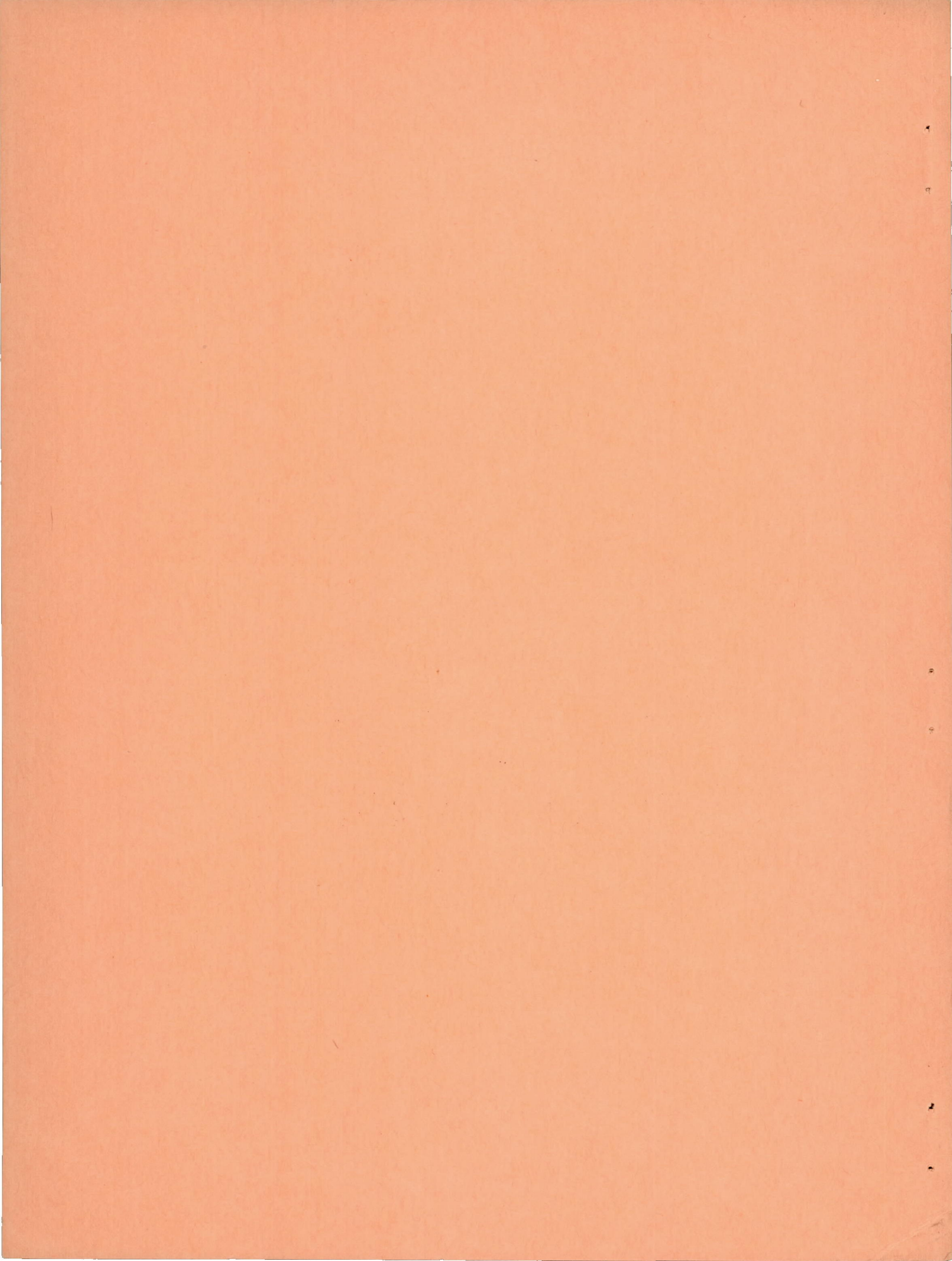

NATIONAL ADVISORY COMMITTEE FOR AERONAUTICS

TECHNICAL NOTE NO. 608

FREE-SPINNING WIND-TUNNEL TESTS OF A LOW-WING MONOPLANE
WITH SYSTEMATIC CHANGES IN WINGS AND TAILS

I. BASIC LOADING CONDITION

By Oscar Seidman and A. I. Neihouse

SUMMARY

A series of tests was made in the N.A.C.A. free-spinning tunnel to determine the effect of systematic changes in wing and tail arrangement upon steady-spinning and recovery characteristics of a conventional low-wing monoplane model for a basic loading condition. Eight wings and three tails, covering a wide range of aerodynamic characteristics, were independently ballasted so as to be interchangeable with no change in mass distribution. For each of the 24 wing-tail combinations, observations were made of steady spins for four control settings and of recoveries for five control manipulations. The results are presented in the form of charts comparing the spin characteristics.

The results showed that, with a poor tail arrangement, wing plan form and tip shape had considerable effect on the spinning characteristics. A wing with rectangular plan form gave noticeably steeper spins and faster recoveries than the same wing with Army tips. Poorest recoveries were obtained for a wing with 5:2 plan-form taper and no thickness taper; rapid recoveries were obtained with a wing having 2:1 taper in both plan form and thickness. For all the wings tested, satisfactory recoveries could be obtained by the use of a tail with a deepened fuselage and a raised stabilizer. Holding the elevators up resulted in the steepest spins from which, by reversal of both controls, the most rapid recoveries were obtained. Steepest spins were generally, though not always, associated with most rapid recovery, but there appeared to be no relation between the sideslip of the steady spin and the turns required for recovery.

INTRODUCTION

As a result of extensive research performed in recent years in flight, on spinning balances, and in free-spinning wind tunnels, a considerable body of data (references 1 to 14 as well as unpublished results from the N.A.C.A. free-spinning tunnel) has been accumulated regarding the effects of inertial and dimensional modifications on the spinning properties of specific airplanes. The information available at present is not, however, sufficient to predict accurately the spinning characteristics of an untried airplane design and actual full-scale or model testing must be resorted to, unless the design incorporates extreme features known to be beneficial in the spin.

In order to secure more comprehensive data that might form the basis for developing design criterions, the N.A.C.A. has undertaken a systematic investigation of which the tests herein reported constitute the first part. The general plan is to determine, by major independent variations, which of the dimensional and mass characteristics most greatly affect the spin. The effects of some minor changes will subsequently be investigated.

It is planned to supplement the preliminary investigation of a low-wing monoplane by brief tests to show comparative effects with a high-wing monoplane and ultimately to extend the investigation to biplanes as well.

The major wing variables selected include tip shape, section, plan form, and flaps. The program included tests of an Army standard tapered wing (reference 15) that combines changes in plan form and thickness. The three tested tail arrangements range from a combination utilizing full-length rudder and raised stabilizer on a considerably deepened fuselage, designed to be extremely efficient in providing yawing moment for recovery, to a more nearly conventional type with rudder completely above a shallow fuselage and badly shielded by the horizontal surfaces.

The present report gives results of tests of eight wings and three tails for the basic loading condition.

The basic loading condition is representative of an average of values for 21 American airplanes for which the moments of inertia were available. Eight other loading conditions to be investigated involve independent varia-

tions of relative density, center-of-gravity location, and moments of inertia. The range to be covered is based on the values for these airplanes.

APPARATUS AND METHODS

A general description of model construction and spin-test technique in the N.A.C.A. free-spinning tunnel is given in reference 11. Since the publication of reference 11 it has been found possible to expedite testing by launching models directly by hand, obviating the use of the launching spindle.

The models are made of balsa, reinforced with spruce and bamboo. In order to secure lightness, the fuselage and wings are hollowed out as necessary, external contours being maintained by means of silk tissue paper on reinforcing ribs. The desired loading is attained by the proper distribution of load weights.

As can be seen in figures 1 to 5, the wing and tail units were independently removable and interchangeable to permit the testing of any combination. The wings and tails were also independently ballasted so that exchange of units could be made without change in mass distribution.

A clockwork delay-action mechanism was installed to actuate the controls for recovery, simulating the rapid motions that would be imparted by a pilot.

The low-wing monoplane model was not scaled from any particular airplane but was designed simply to be a representative low-wing cabin monoplane with cowled radial engine and with landing gear retracted. Over-all dimensions are given in figure 1.

For convenience in making comparisons the model may be considered to be a 1/15-scale model of either a fighter or a four-place cabin airplane, tested at an altitude of 6,000 feet. In this case the full-scale characteristics with the basic loading and tail C would be:

Weight (W)	4,720 lb.
Mean chord (c)	75 in.

Span (b)	37.5 ft.
Wing area (S)	234.4 sq. ft.
Aspect ratio	6
Distance from c.g. to elevator hinge	16.6 ft.
Distance from c.g. to rudder hinge	16.9 ft.
Fin area	6.8 sq. ft.
Rudder area	6.9 sq. ft.
Stabilizer area	19.8 sq. ft.
Elevator area	12.9 sq. ft.
Control travel	Rudder: $\pm 30^\circ$ Elevator: 30° up, 20° down

Principal moments of inertia:

A	2,760 slug-ft. ²
B	3,970 slug-ft. ²
C	6,150 slug-ft. ²
x/c	0.25
z/c	0

The quantity x/c is the ratio of the distance of the center of gravity back of the leading edge of the mean chord to the mean chord; and z/c is the ratio of the distance of the center of gravity below the thrust line to the mean chord.

Figures 1 and 4 show the model with the basic wing (wing 1) and the smallest tail (tail C) installed. This wing is of N.A.C.A. 23012 section with rectangular plan form and Army tips. (The tip contour is derived as described in reference 16.) In common with the seven other

wings tested, it had an area of 150 square inches, a span of 30 inches, and no dihedral, twist, or sweepback.

The seven remaining wings (figs. 2 and 5) have varied dimensional characteristics as follows:

- Wing 2: N.A.C.A. 23012 section, rectangular with Army tips, 20 percent split flaps deflected 60° .
- Wing 3: N.A.C.A. 23012 section, rectangular with rectangular tips.
- Wing 4: N.A.C.A. 23012 section, rectangular with faired tips.
- Wing 5: N.A.C.A. 0009 section, rectangular with Army tips.
- Wing 6: N.A.C.A. 6718 section, rectangular with Army tips.
- Wing 7: N.A.C.A. 23012 section, 5:2 taper with Army tips.
- Wing 8: N.A.C.A. 23018-09 section, Army standard plan form (square center section; 2:1 taper in both plan form and thickness, and rounded tip).

The three tails tested are designated A, B, and C. The conventional arrangement of a shallow fuselage with rudder completely above the tail cone is represented by tail C. The dimensional characteristics of this tail are:

Vertical tail area, 6 percent wing area (3 percent rudder and 3 percent fin).

Fuselage side area, back of leading edge of stabilizer, 2 percent wing area.

Vertical tail length (from quarter-chord point to rudder hinge axis), 45 percent wing span.

Horizontal tail area, 14 percent wing area (5.5 percent elevator and 8.5 percent stabilizer).

Horizontal tail length (from quarter-chord point to elevator hinge axis), 44 percent wing span.

Tail B (figs. 3 and 5) was derived from tail C by increasing the fuselage depth, raising the stabilizer and elevators, and installing approximately the original fin and rudder atop the deepened fuselage.

For tail B with the same tail lengths as tail C, the dimensional characteristics are:

Vertical tail area, 6 percent wing area.

Fuselage side area, 5.5 percent wing area.

Horizontal tail area, 14 percent wing area.

Tail A (figs. 3 and 5), with same tail lengths as for B and C, was similar to tail B except for full-length rudder construction and slightly increased elevator cut-out:

Vertical tail area, 8.0 percent wing area (5 percent rudder and 3 percent fin).

Fuselage side area, 3.4 percent wing area.

Horizontal tail area, 14 percent wing area.

The model loading (for the equivalent test altitude of 6,000 feet) corresponded to the following mass-distribution parameters at zero altitude ($\rho = 0.002378$):

$$\mu = \frac{W}{g\rho S b} = 7$$

$$\frac{W b^2}{g(C - A)} = 61$$

$$\frac{C - B}{C - A} = 0.64$$

$$\frac{b}{k_X} = 8.7 \text{ (where } k_X \text{ is the radius of gyration about the X axis)}$$

$$x/c = 0.25$$

$$z/c = 0$$

RESULTS AND PRECISION

For each wing and tail combination, spin tests were made for four control settings:

- (a) rudder 30° with the spin and elevators neutral.
- (b) rudder 30° with the spin and elevators 20° down.
- (c) rudder 30° with the spin and elevators 30° up.
- (d) rudder neutral and elevators neutral.

Recovery from conditions (a) and (b) was attempted by reversal of the rudder, from (c) by complete reversal of both controls and also by neutralizing both controls, and from (d) by moving both controls to fully deflected against the spin. All tests were for right spins.

The angle of attack α , angle of sideslip β (positive inward in a right spin), turns for recovery, spin coefficient $\Omega b/2V$, and rate of descent V are plotted in 12 charts (figs. 6 to 17) grouped so as to permit ready comparison of the effects of tip shape, section, plan form, flaps, and Army wing.

The data on these charts are believed to represent the true model values within the following limits (see reference 11):

α	$\pm 3^\circ$
β	$\pm 1-1/2^\circ$
Turns for recovery	$\pm 1/4$ turn
$\frac{\Omega b}{2V}$	± 3 percent
V	± 2 percent

For certain spins that are difficult to control in the tunnel, owing to high air speed or wandering motion, the foregoing limits may be exceeded.

DISCUSSION

Tests with tail A (figs. 6 to 9).- A comparison of the results given in figure 6 for tail A and different wings (for rudder 30° with and elevators neutral) shows that the rectangular wings with rectangular or faired tips (wings 3 and 4) gave the steepest spins ($\alpha = 47^\circ$ compared with 60° for the flattest) and the fastest recoveries (1-1/2 turns). The wing of N.A.C.A. 6718 section (wing 6) gave the least outward sideslip; the wing with 5:2 taper (wing 7) and the wing with flaps (wing 2) gave the slowest recoveries (4 turns).

With elevators 20° down (fig. 7) the spins were very similar to those for elevators neutral. Elevators up (fig. 8) definitely steepened the spins (by about 8° for the flatter spins) and gave rapid recoveries by reversal of both controls. With controls neutral (fig. 9) a spin could be obtained only with the 5:2 taper wing, the model recovering of its own accord when forced into a spin for all other cases.

For all control settings, rectangular and faired tips gave the steepest spins and best recoveries (no more than 1-1/2 turns). The wing of N.A.C.A. 6718 section gave the least outward sideslip of all wings and a slightly lower angle of attack than the two comparable wings of N.A.C.A. 23012 and of N.A.C.A. 0009 sections, but airfoil section had no apparent effect on the turns for recovery. The poorest recoveries were obtained for the wing with flaps and the wing of 5:2 taper but the Army tapered wing (wing 8) was similar in behavior to the basic rectangular N.A.C.A. 23012 wing with Army tips (wing 1).

Tests with tail B (figs. 10 to 13).- Figure 10 gives results for the various wings with tail B for rudder with the spin and elevators neutral and shows general agreement with the results for tail A (fig. 6) except that the spins were roughly 10° steeper. This result is not unexpected as the control position might be interpreted as resulting from neutralizing the lower half of the full-length rudder of tail A.

As with tail A, the rectangular and faired tips gave the steepest spins. Although the rate of descent was too great for complete testing of the model, it is believed that recovery would have been rapid.

With elevators down (fig. 11) the spins were similar to those for elevators neutral. (The rectangular wing with faired tips appeared to give a critical spin condition: the model would sometimes continue to spin but generally would recover of its own accord after a number of turns.) Deflecting the elevators up (fig. 12) steepened the spin, making it, in general, too fast and oscillatory to be maintained in the tunnel.

With both controls neutral, tail B is almost identical in configuration and dimensions with tail A except for the slightly larger elevator cut-out of tail A. As might be anticipated, the steady-spin results in figure 13 are almost identical with the corresponding results given for tail A in figure 9: a spin could be obtained only for the case of the wing of 5:2 taper. It is worth noting that, with tail B, for both controls neutral, several of the wings (1, 6, and 8) appeared to give inconsistent results and additional tests were therefore performed. It was observed that, although a steady spin could sometimes be obtained by the use of extreme care in launching, the model generally would not spin. The apparent slight inferiority of tail B as compared with tail A is possibly attributable to the relatively larger rudder-shielding effect due to the smaller elevator cut-out of tail B.

For all control settings the rectangular wing with rectangular or faired tips again gave the steepest spins and the quickest recoveries and the N.A.C.A. 6718 wing gave the least outward sideslip. For controls with the spin there was little other effect of section, and the flaps again retarded recovery. As before, the wing of 5:2 taper gave poorest recovery, but the Army standard tapered wing was satisfactory.

Tests with tail C (figs. 14 to 17).-- With tail C the effects of individual wing differences were more apparent. Figure 14 (rudder with and elevators neutral) again shows the steepest spins ($\alpha = 40^\circ$) and quickest recoveries (2 turns) for rectangular wings with rectangular or faired tips. By comparison the Army tip ($\alpha = 60^\circ$ and 10-turn recovery) was considerably poorer.

As before, the N.A.C.A. 6718 wing gave the least outward sideslip. There is a definite effect of section on recovery, N.A.C.A. 0009 being the best (5 turns) and N.A.C.A. 6718 the worst (no recovery) although the angle of attack was smaller for the N.A.C.A. 6718 than for the

other two sections. The 5:2 taper and flaps are again adverse, giving no recovery.

Elevator-down spins (fig. 15) were very similar to elevator-neutral spins except that recovery was, in general, somewhat faster. Deflecting the elevators up (fig. 16) steepened the spin, making it difficult, in some cases, to test the model in the tunnel. (Recovery was considerably more rapid when the controls were reversed than when they were merely neutralized.) With both controls neutral (fig. 17), spins could not be obtained for the wings with rectangular and faired tips.

For all control settings the rectangular wings with rectangular or faired tips gave the steepest spins and most rapid recoveries. The N.A.C.A. 0009 wing gave fair recoveries, but the remaining wings were unsatisfactory with tail C, except for the case of complete reversal of both controls from fully deflected with to fully deflected against the spin, a procedure that gave good recoveries for all except the wing with flaps.

CONCLUSIONS

By a comparative analysis of the data presented, the general effects of wing or tail arrangement and of control position and the apparent relationships between spin characteristics may be determined for the basic loading condition.

Effects of wings:

1. Tip shape.-- Rectangular and faired tips give the steepest spins ($\alpha < 48^\circ$) and the most rapid recoveries (turns $< 2\frac{1}{2}$). The Army tip gives consistently flatter spins (α to 60°) and slower recoveries (to 10 turns). There is no consistent effect of tip shape on sideslip.

2. Section.-- With tail C the N.A.C.A. 6718 wing gives a steeper spin than the other two sections but no recovery; the N.A.C.A. 0009 section gives fair recovery, and the 23012 section gives poor recovery. The N.A.C.A. 6718 section consistently gives the least outward sideslip.

3. Flaps.-- Flaps tend to retard recovery.

4. Plan form.— The wing of 5:2 taper consistently gives the poorest recoveries.

5. Army standard wing.— The Army standard wing is equal to or slightly better than the rectangular wing with Army tips.

Effects of tail arrangement:

For controls with the spin, tail B gives steeper spins than tail A and recovery is generally satisfactory for either tail. Tail C generally gives slower recoveries than either tails A or B.

Effects of control settings:

1. For certain wings, recovery is slightly more rapid from spins with elevators down than from spins with elevators neutral, but in general there is little difference.

2. Holding elevators up results in the steepest spins from which, by reversal of both controls, are obtained the most rapid recoveries.

Relationships between spin characteristics:

1. Steep spins are associated with high rate of descent and low $\Omega b/2V$.

2. There appears to be no direct relationship between sideslip of the steady spin and turns required for recovery.

3. Except for the case of the N.A.C.A. 6718 wing with tail C, steeper spins are associated with faster recoveries.

Langley Memorial Aeronautical Laboratory,
National Advisory Committee for Aeronautics,
Langley Field, Va., July 15, 1937.

REFERENCES

1. Stephens, A. V.: Free-Flight Spinning Experiments with Single-Seater Aircraft H and Bristol Fighter Models. R. & M. No. 1404, British A.R.C., 1931.
2. Irving, H. B., Batson, A. S., and Stephens, A. V.: Spinning Experiments on a Single Seater Fighter with Deepened Body and Raised Tailplane. R. & M. No. 1421, British A.R.C., 1932.
3. Stephens, A. V., and Francis, R. H.: Model Spinning Tests of an Interceptor Fighter. R. & M. No. 1578, British A.R.C., 1934.
4. Stephens, A. V.: Recent Research on Spinning. R.A.S. Jour., vol. XXXVII, no. 275, Nov. 1933, pp. 944-955.
5. Bamber, M. J., and Zimmerman, C. H.: Effect of Stabilizer Location upon Pitching and Yawing Moments in Spins as Shown by Tests with the Spinning Balance. T.N. No. 474, N.A.C.A., 1933.
6. Scudder, N. F.: A Flight Investigation of the Effect of Mass Distribution and Control Setting on the Spinning of the XN2Y-1 Airplane. T.R. No. 484, N.A.C.A., 1934.
7. Stephens, A. V.: Das Trudeln von Flugzeugen. Luftfahrtforschung, Bd. 11, Nr. 5, 25 Okt. 1934, S. 140-149.
8. Francis, R. H.: Interim Report on Systematic Model Research in Free Spins: Low Wing Monoplanes. R. & M. No. 1714, British A.R.C., 1936.
9. Scudder, N. F., and Seidman, Oscar: A Flight Investigation of the Spinning of the F4B-2 Biplane with Various Loads and Tail Surfaces. T.R. No. 529, N.A.C.A., 1935.
10. Irving, H. B., Batson, A. S., and Warsap, J. H.: The Contribution of the Body and Tail of an Aeroplane to the Yawing Moment in a Spin. R. & M. No. 1689, British A.R.C., 1936.

11. Zimmerman, C. H.: Preliminary Tests in the N.A.C.A. Free-Spinning Wind Tunnel. T.R. No. 557, N.A.C.A., 1936.
12. Zimmerman, C. H.: Effect in Changes in Tail Arrangement upon the Spinning of a Low-Wing Monoplane Model. T.N. No. 570, N.A.C.A., 1936.
13. Bamber, M. J.: Aerodynamic Effects of a Split Flap on the Spinning Characteristics of a Monoplane Model. T.N. No. 515, N.A.C.A., 1934.
14. Bamber, M. J., and House, R. O.: Spinning Characteristics of the XN2Y-1 Airplane Obtained from the Spinning Balance and Compared with Results from the Spinning Tunnel and from Flight Tests. T. R. No. 607, N.A.C.A., 1937.
15. Matériel Division, U. S. Army Air Corps: Handbook of Instructions for Airplane Designers. Eighth edition, revision 6, vol. I, March 1934, p. 76f.
16. Shortal, Joseph A.: Effect of Tip Shape and Dihedral on Lateral-Stability Characteristics. T.R. No. 548, N.A.C.A., 1935.

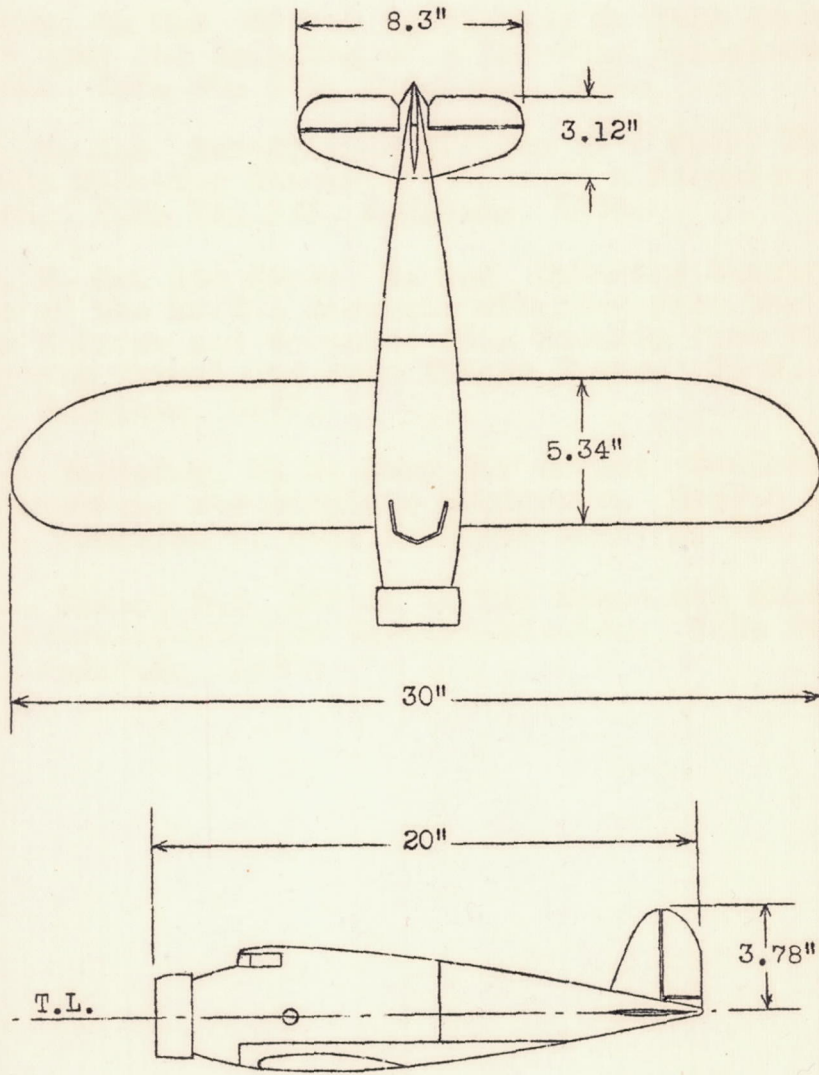

Figure 1.- Low-wing monoplane model with detachable tail and wing.

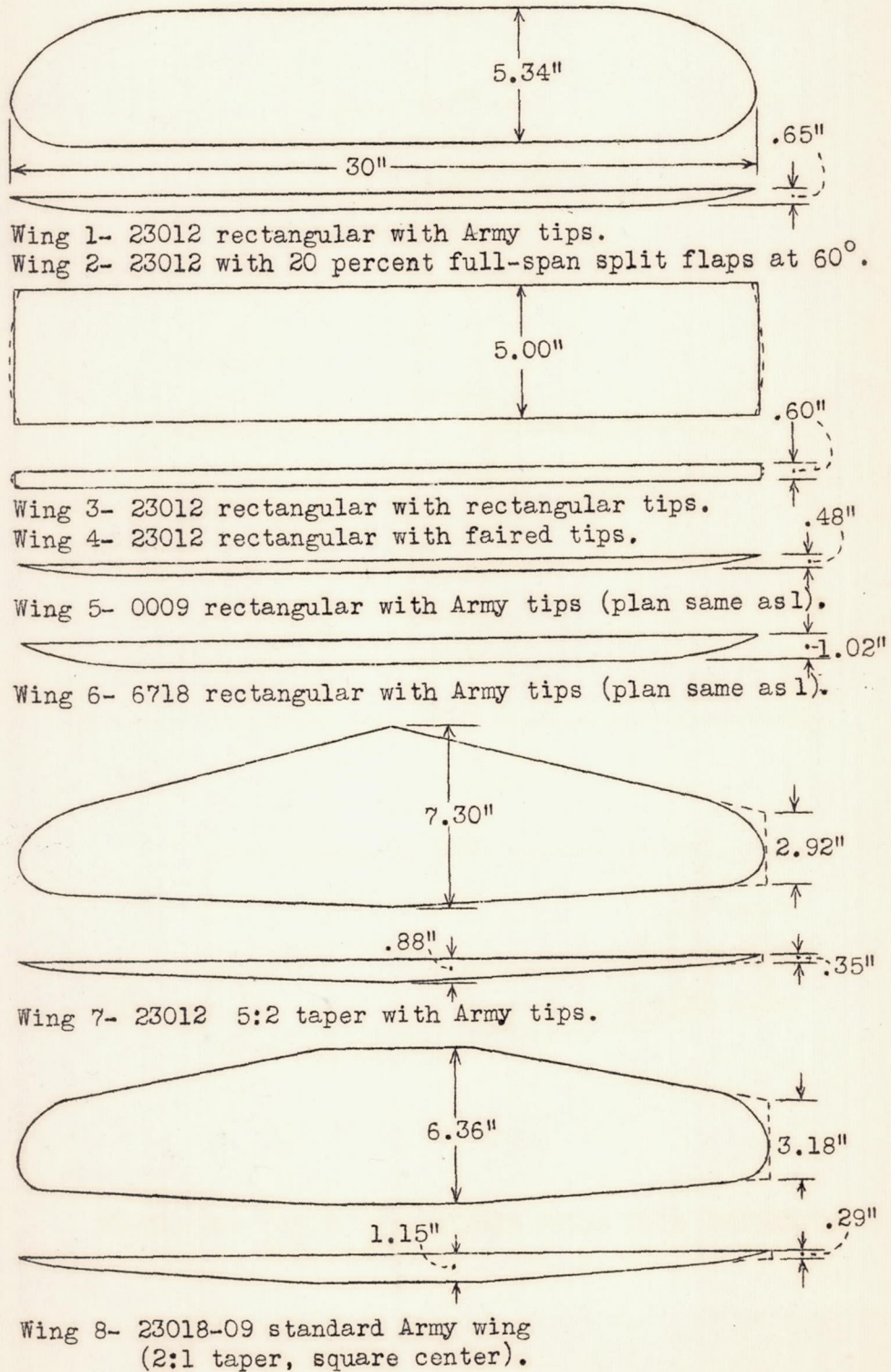

Figure 2.- Wings used on low-wing monoplane.
 N.A.C.A. wing sections.

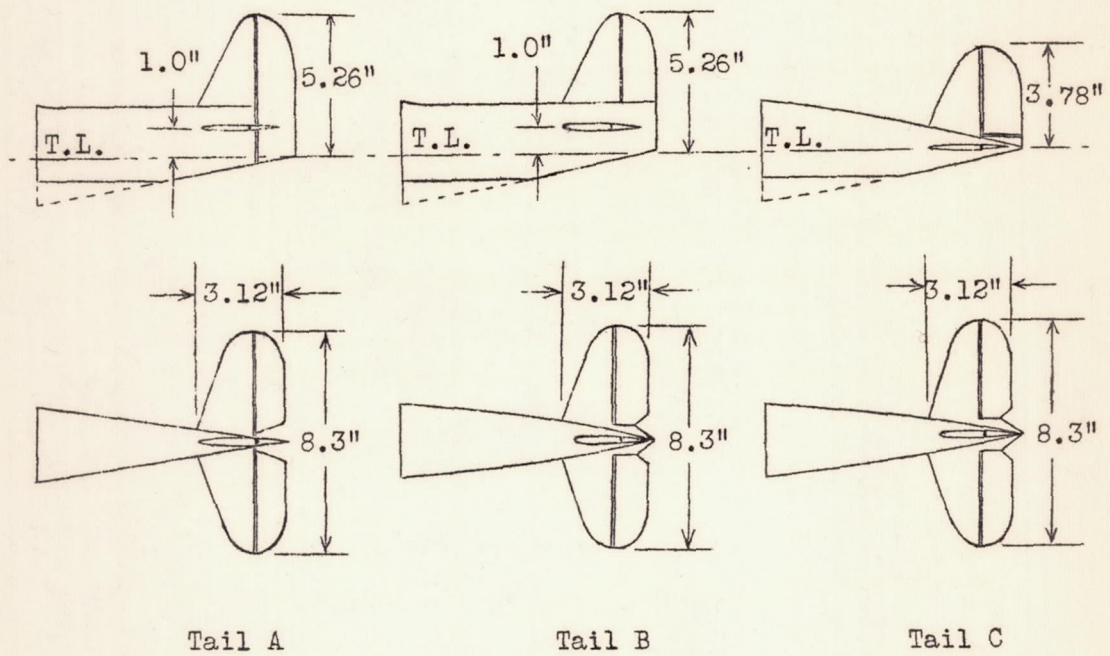
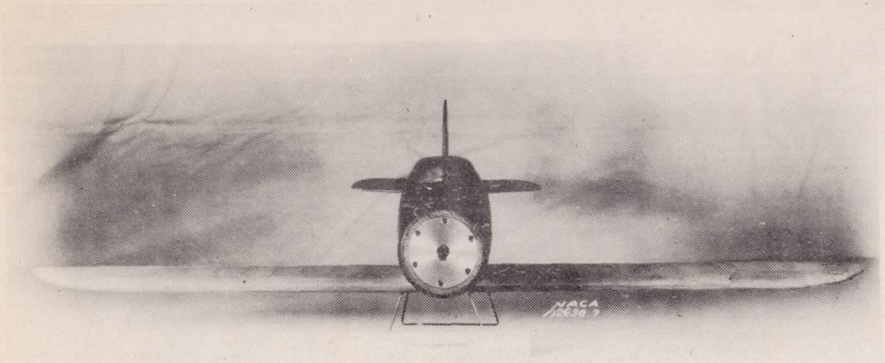
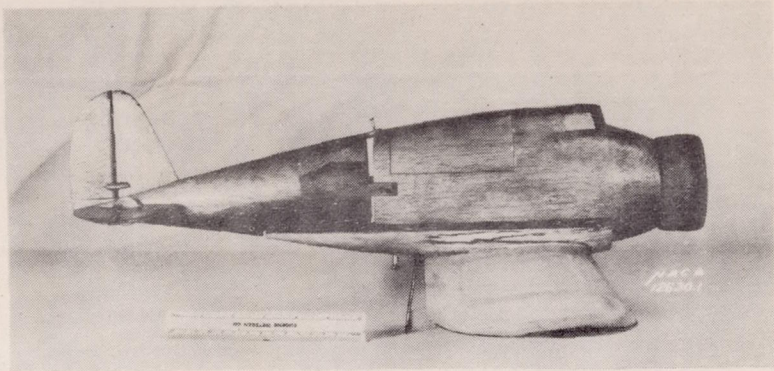

Figure 3.- Tails used on low-wing monoplane.



(a) Front view.



(c) Side view, showing detachable parts.

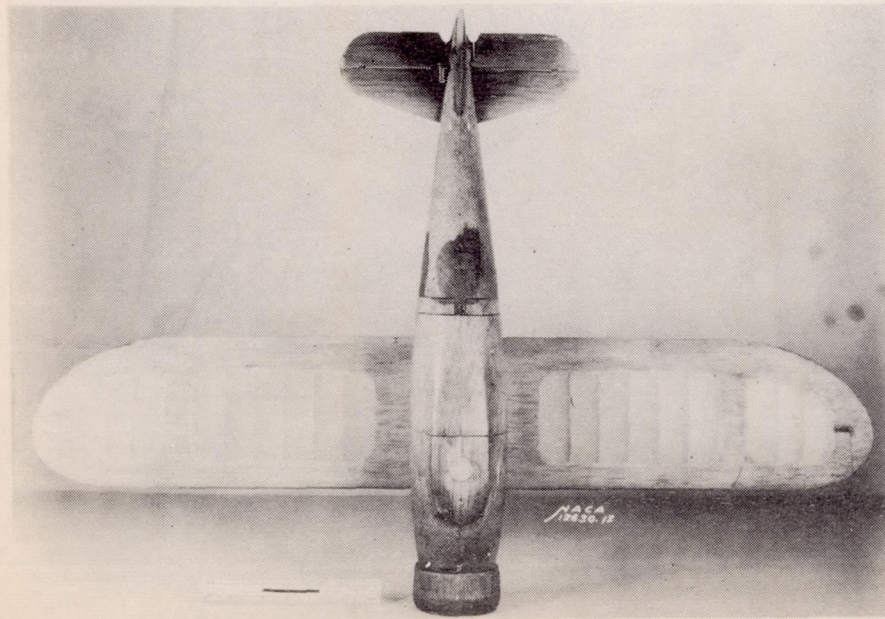

(b) Plan view.

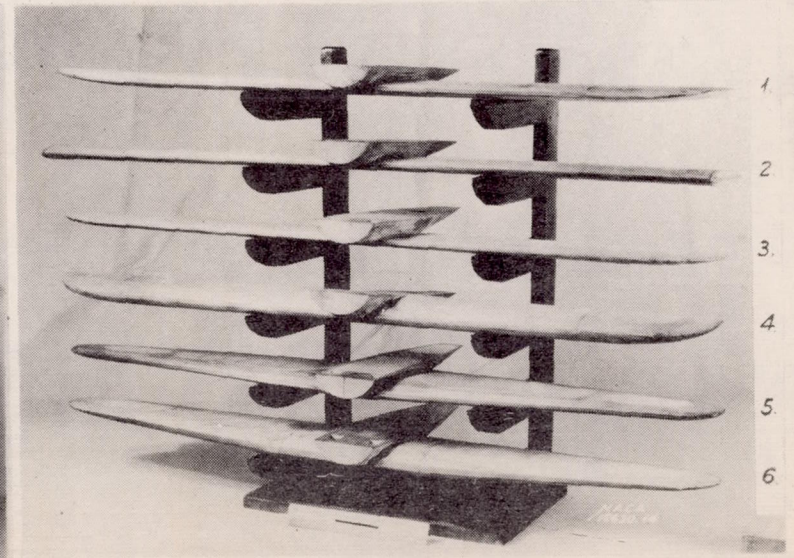

(1) Wings 1 and 2, (2) Wings 3 and 4, (3) Wing 5,
(4) Wing 6, (5) Wing 7 (6) Wing 8.
(d) Low-wing monoplane wings.

Figure 4. - Low-wing monoplane model.

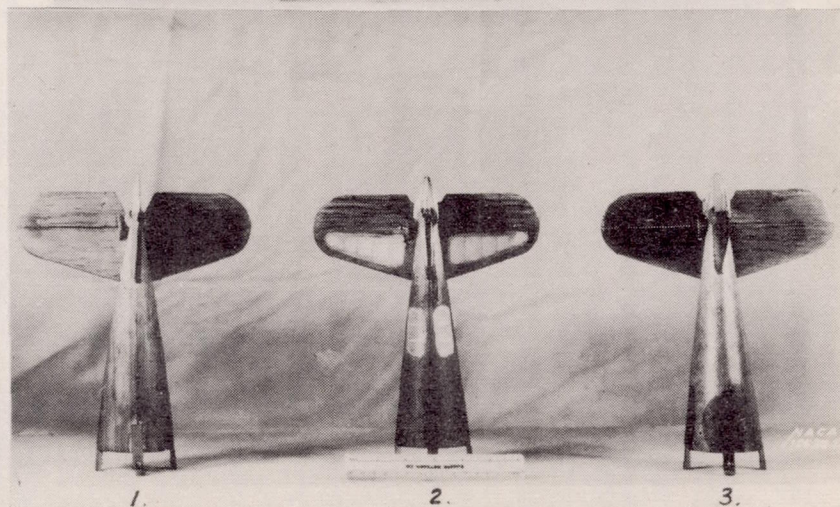
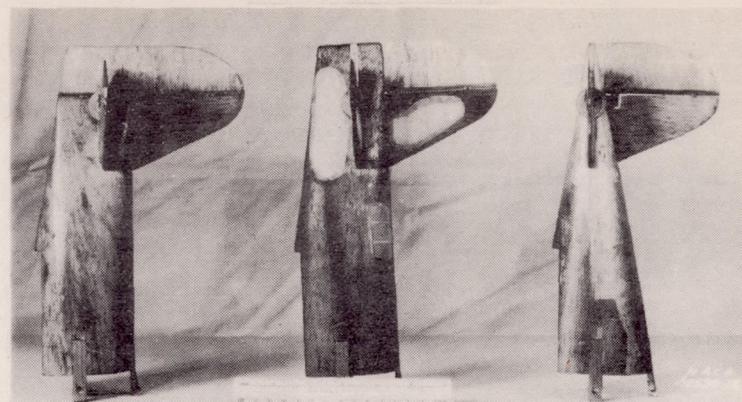
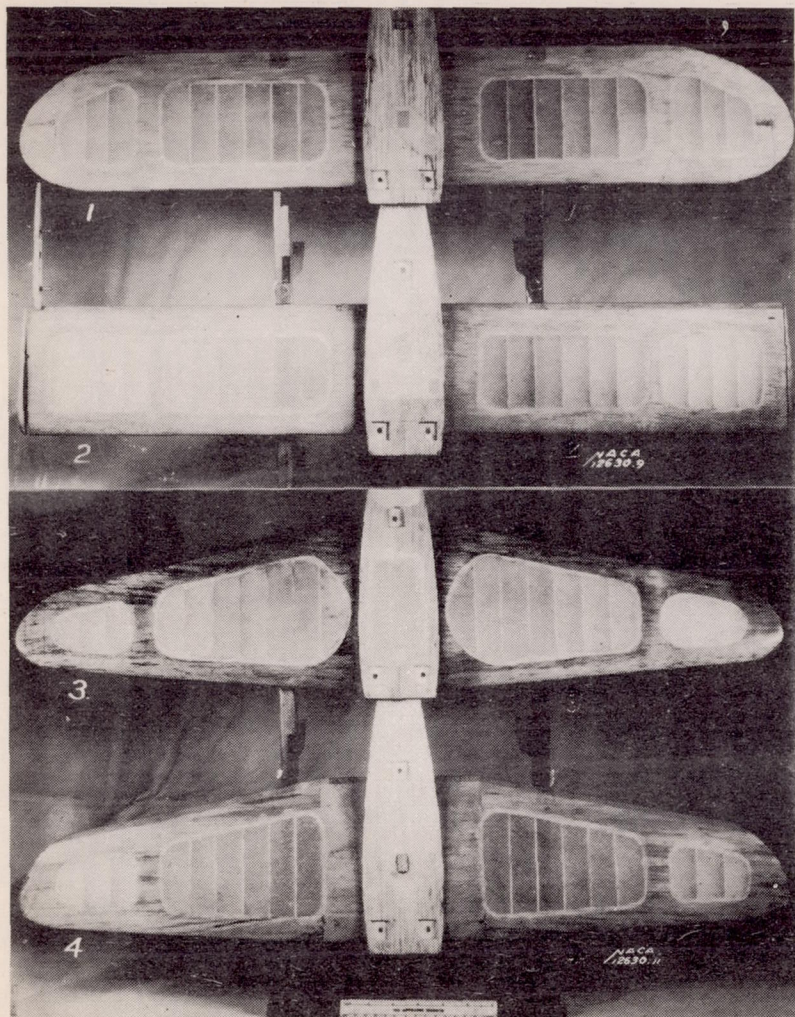

- (b) (1) Tail A, deep fuselage and long rudder.
 (2) Tail B, deep fuselage and short rudder.
 (3) Tail C, shallow fuselage and short rudder.

- (a) (1) Rectangular wing with Army tips. (2) Rectangular wing with interchangeable rectangular and faired tips.
 (3) 5:2 tapered wing with Army tips.
 (4) 2:1 Army standard tapered wing with square center.

Figure 5.- Interchangeable wings and tails of low-wing monoplane model.

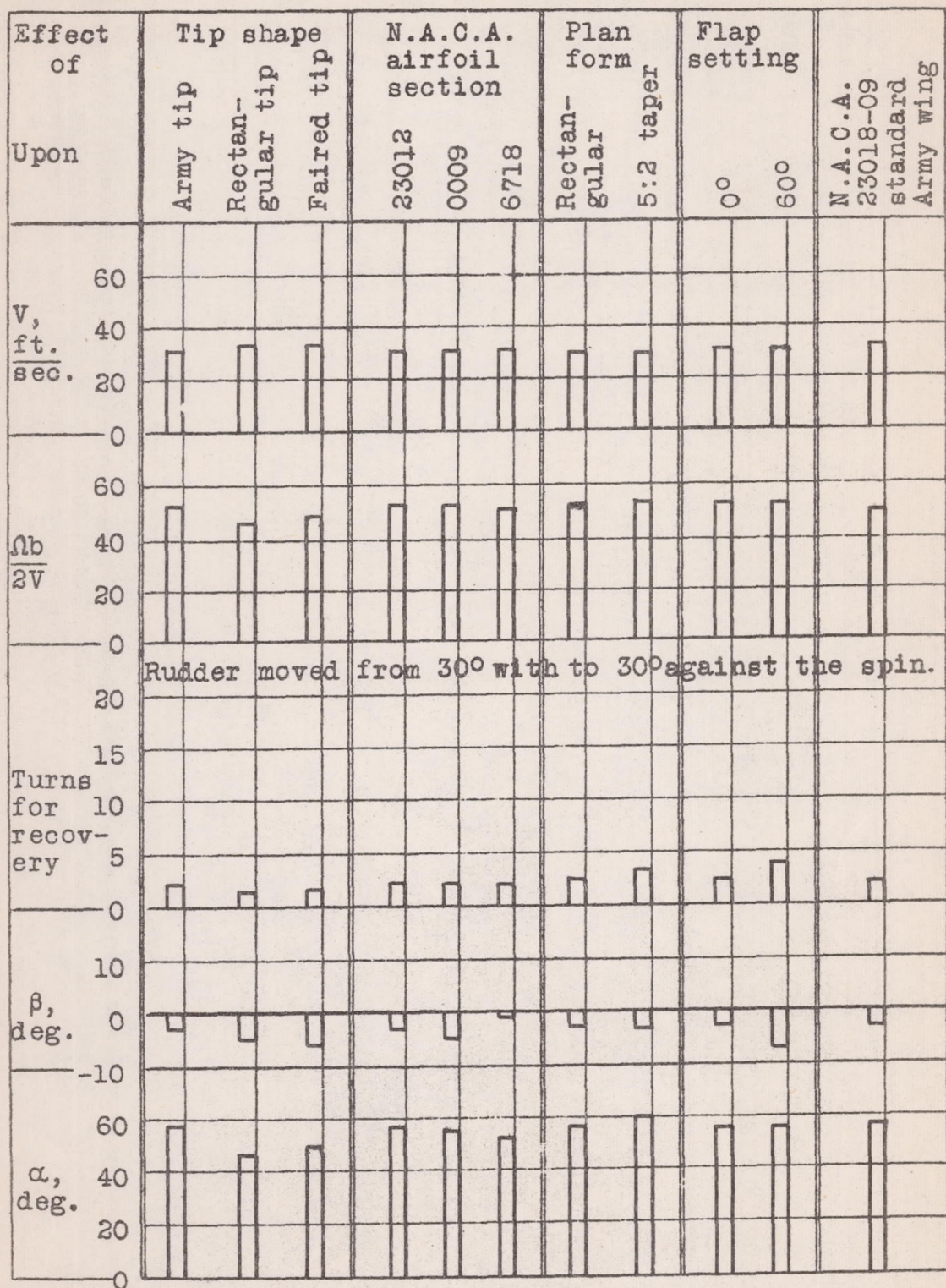

Figure 6 .-The effect of various wings on the spin characteristics. Basic loading condition; tail A, rudder 30° with, elevators 0° , ailerons 0° (Wing has rectangular plan form, Army tips, N.A.C.A.23012 section, except as noted.)

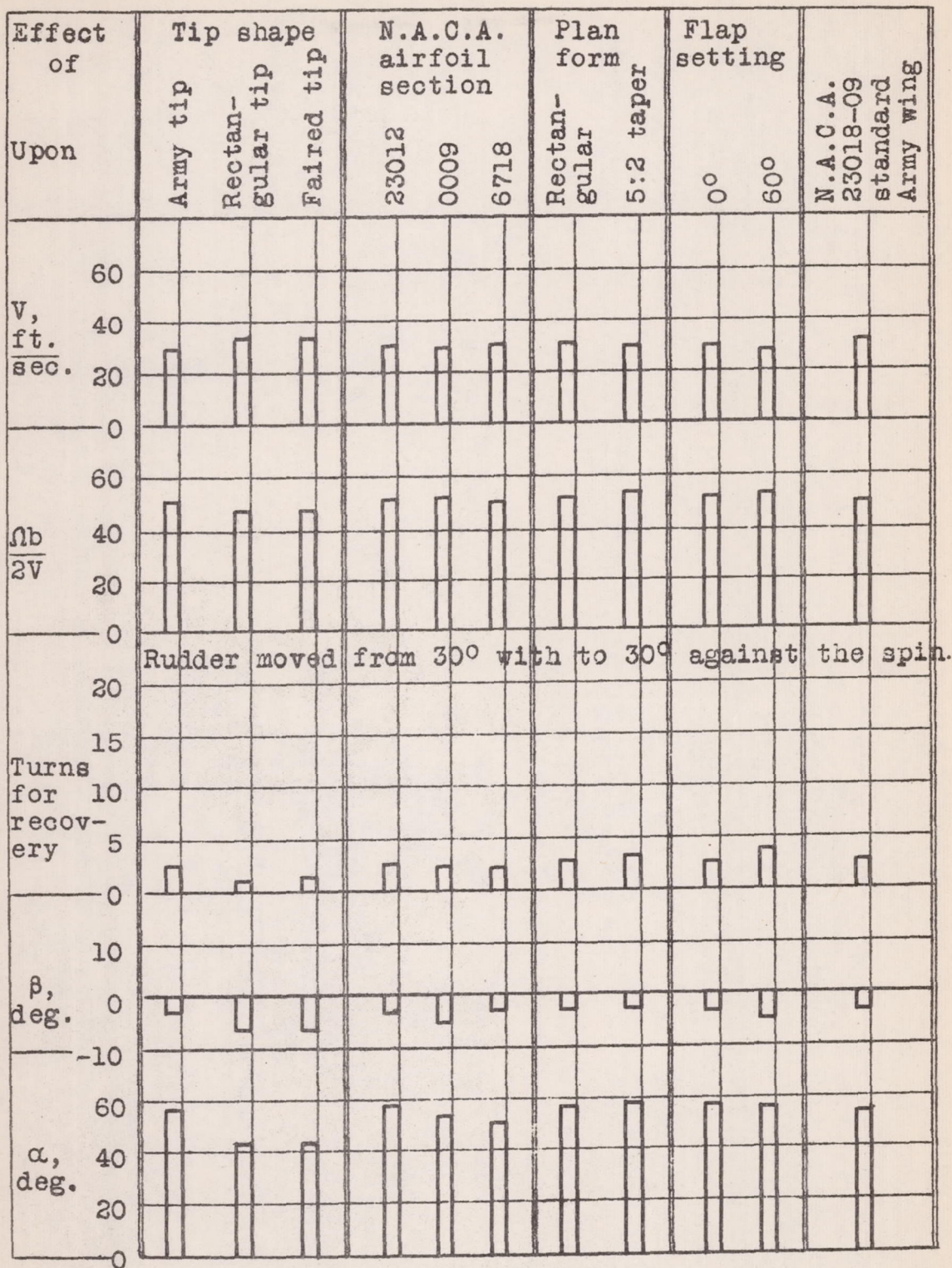

Figure 7 .-The effect of various wings on the spin characteristics. Basic loading condition; tail A, rudder 30° with, elevators 20° down, ailerons 0° (Wing has rectangular plan form, Army tips, N.A.C.A.23012 section, except as noted.)

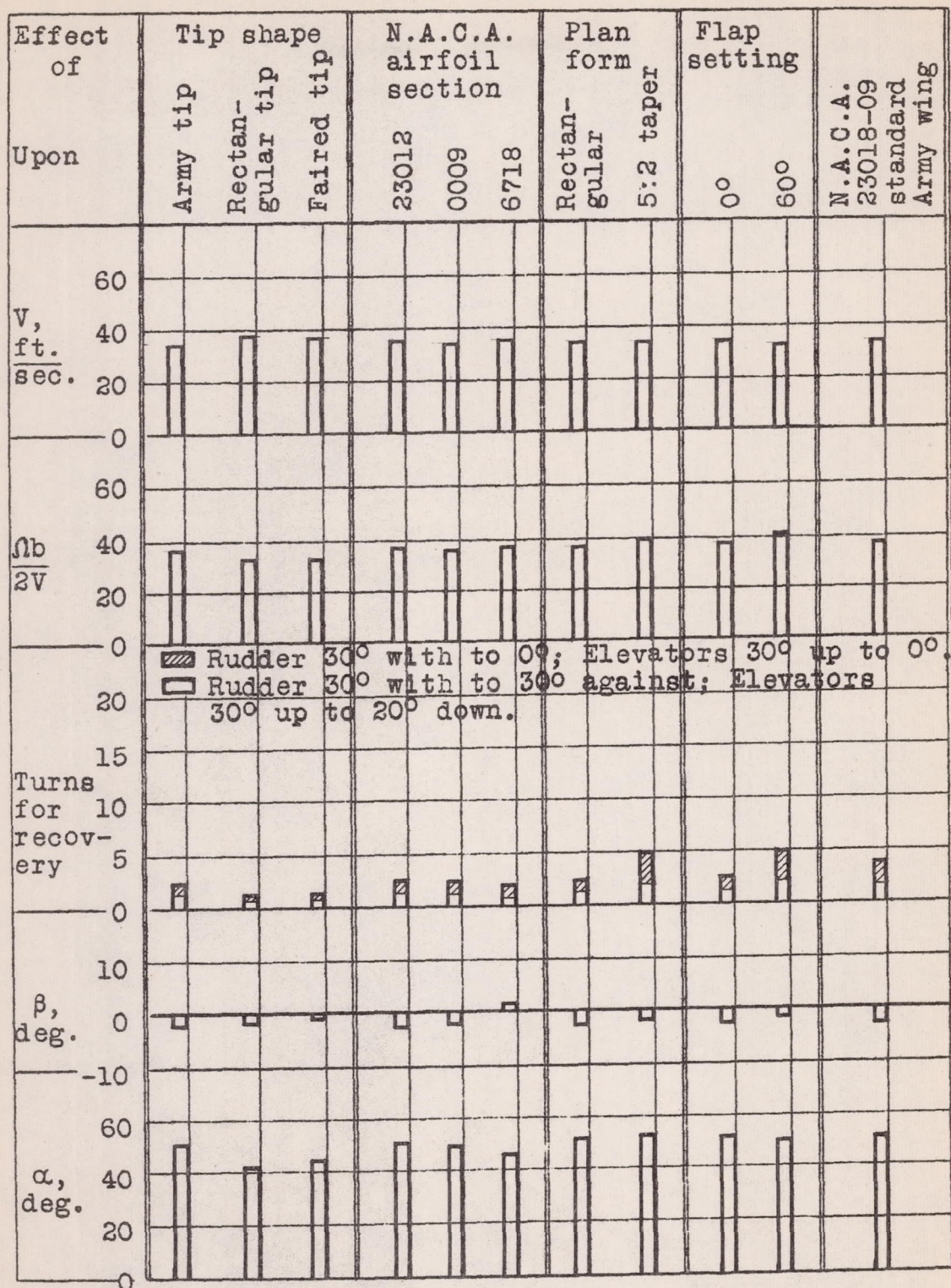

Figure 8 .-The effect of various wings on the spin characteristics. Basic loading condition; tail A, rudder 30° with, elevators 30° up, ailerons 0° (Wing has rectangular plan form, Army tips, N.A.C.A. 23012 section, except as noted.)

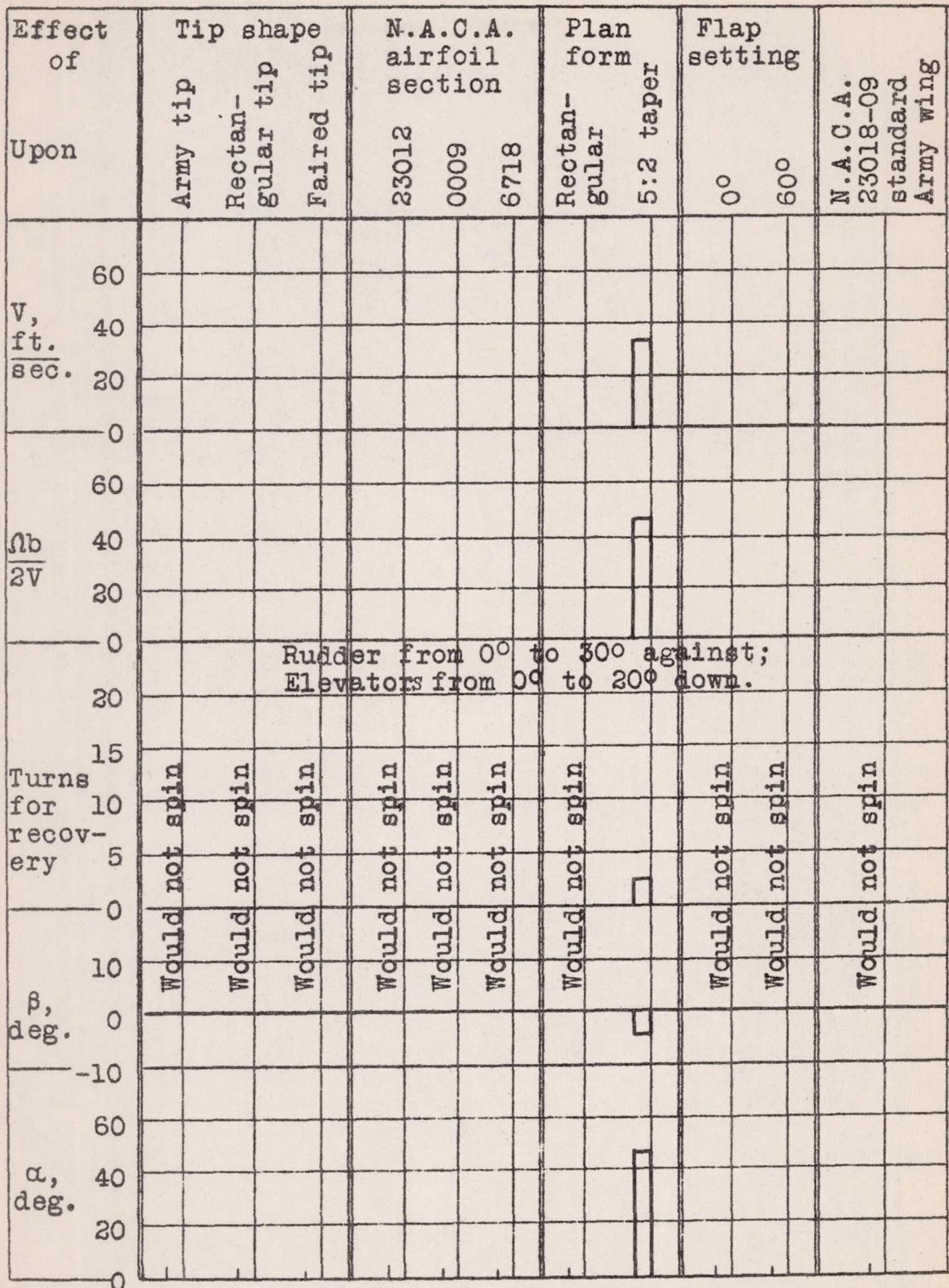

Figure 9 .-The effect of various wings on the spin characteristics. Basic loading condition; tail A, rudder 0° with, elevators 0° , ailerons 0° (Wing has rectangular plan form, Army tips, N.A.C.A.23012 section, except as noted.)

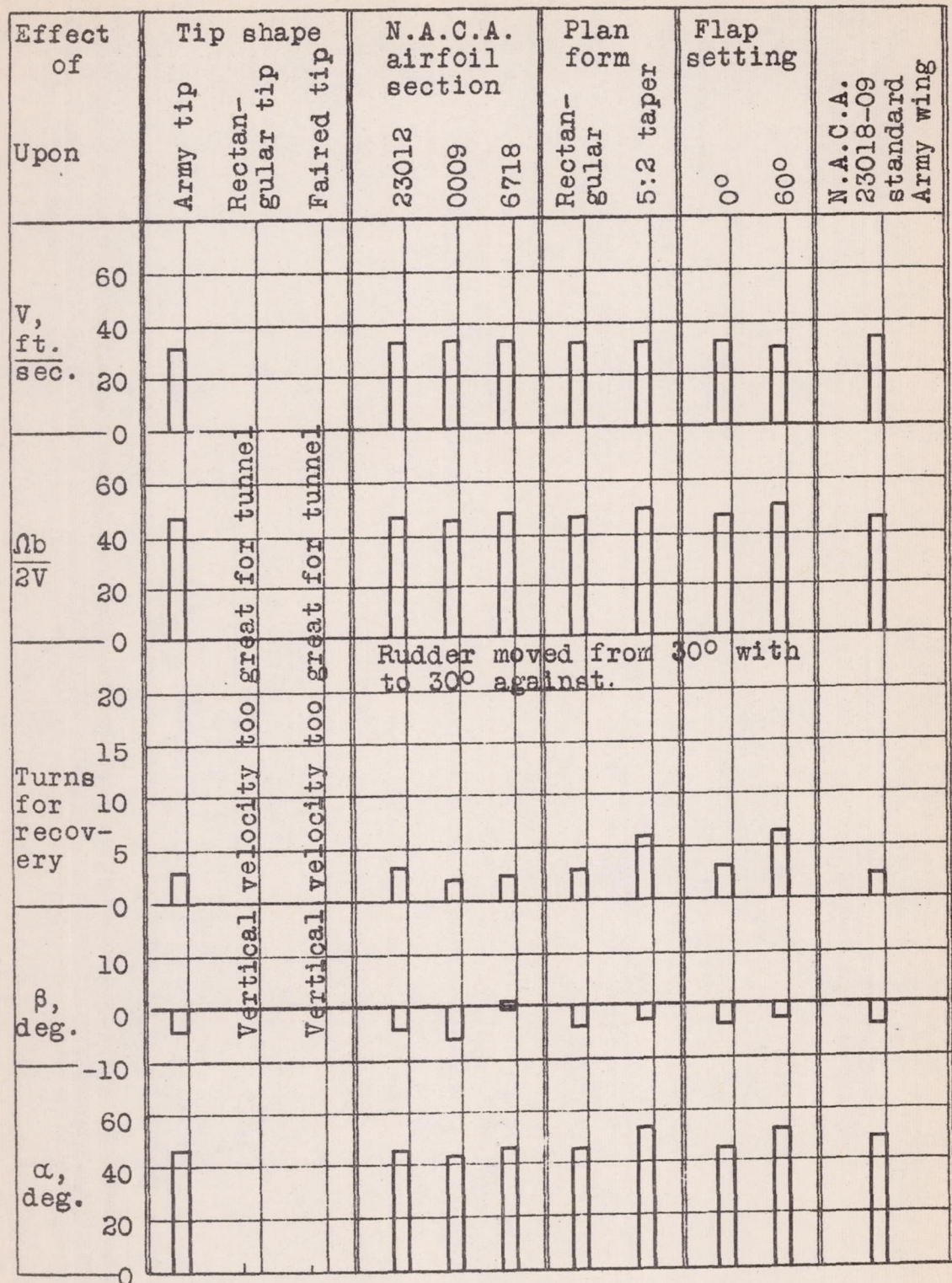

Figure 10 .--The effect of various wings on the spin characteristics. Basic loading condition; tail B, rudder 30° with, elevators 0°, ailerons 0° (Wing has rectangular plan form, Army tips, N.A.C.A. 23012 section, except as noted.)

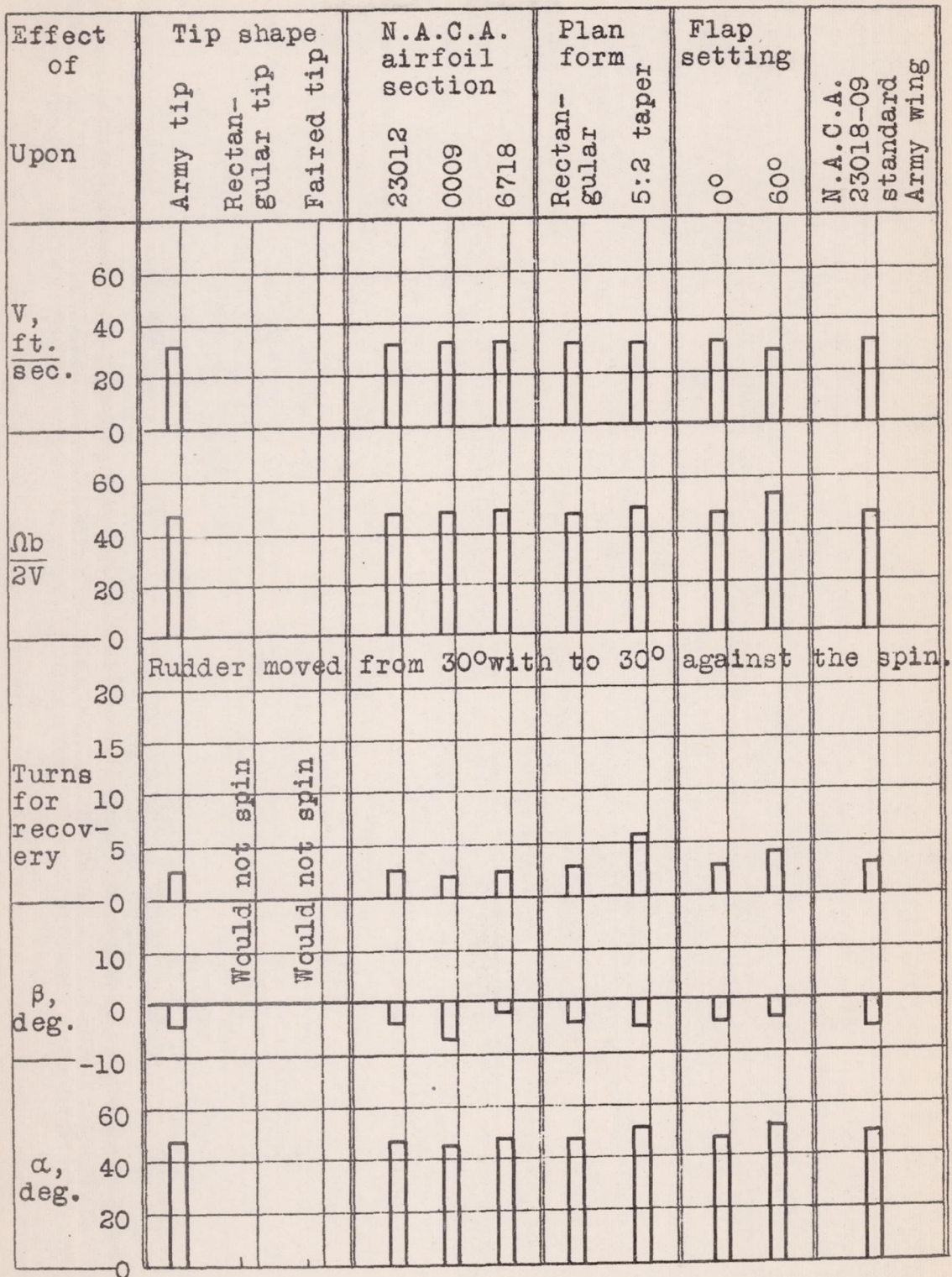

Figure 11 .-The effect of various wings on the spin characteristics. Basic loading condition; tail B, rudder 30° with, elevators 20° down, ailerons 0° (Wing has rectangular plan form, Army tips, N.A.C.A.23012 section, except as noted.)

Effect of	Tip shape			N.A.C.A. airfoil section			Plan form		Flap setting		N.A.C.A. 23018-09 standard Army wing	
	Upon	Army tip	Rectangular tip	Faired tip	23012	0009	6718	Rectangular	5:2 taper	0°		60°
V, ft. sec.	60											
	40											
	20											
	0											
	60											
$\frac{\Omega b}{2V}$	60	for tunnel	for tunnel	for tunnel	for tunnel	for tunnel	for tunnel	for tunnel	for tunnel	for tunnel	for tunnel	for tunnel
	40	great	great	great	great	great	great	great	great	great	great	great
	20	too	too	too	too	too	too	too	too	too	too	too
	0	velocity	velocity	velocity	velocity	velocity	oscillatory	velocity	velocity	velocity	oscillatory	velocity
	20	too	too	too	too	too	to hold in	too	too	too	to hold in	too
Turns for recovery	15	too	too	too	too	too	too	too	too	too	too	too
	10	velocity	velocity	velocity	velocity	velocity	oscillatory	velocity	velocity	velocity	oscillatory	velocity
	5	too	too	too	too	too	to hold in	too	too	too	to hold in	too
	0	vertical	vertical	vertical	vertical	vertical	spin	vertical	vertical	vertical	spin	vertical
	10	too	too	too	too	too	too oscillatory	too	too	too	too oscillatory	too
β , deg.	0	Vertical	Vertical	Vertical	Vertical	Vertical	Spin	Vertical	Vertical	Vertical	Spin	Vertical
	-10	too	too	too	too	too	too	too	too	too	too	too
	60											
α , deg.	40											
	20											
	0											

Figure 12 .--The effect of various wings on the spin characteristics. Basic loading condition; tail B, rudder 30° with, elevators 30° up, ailerons 0° (Wing has rectangular plan form, Army tips, N.A.C.A. 23012 section, except as noted.)

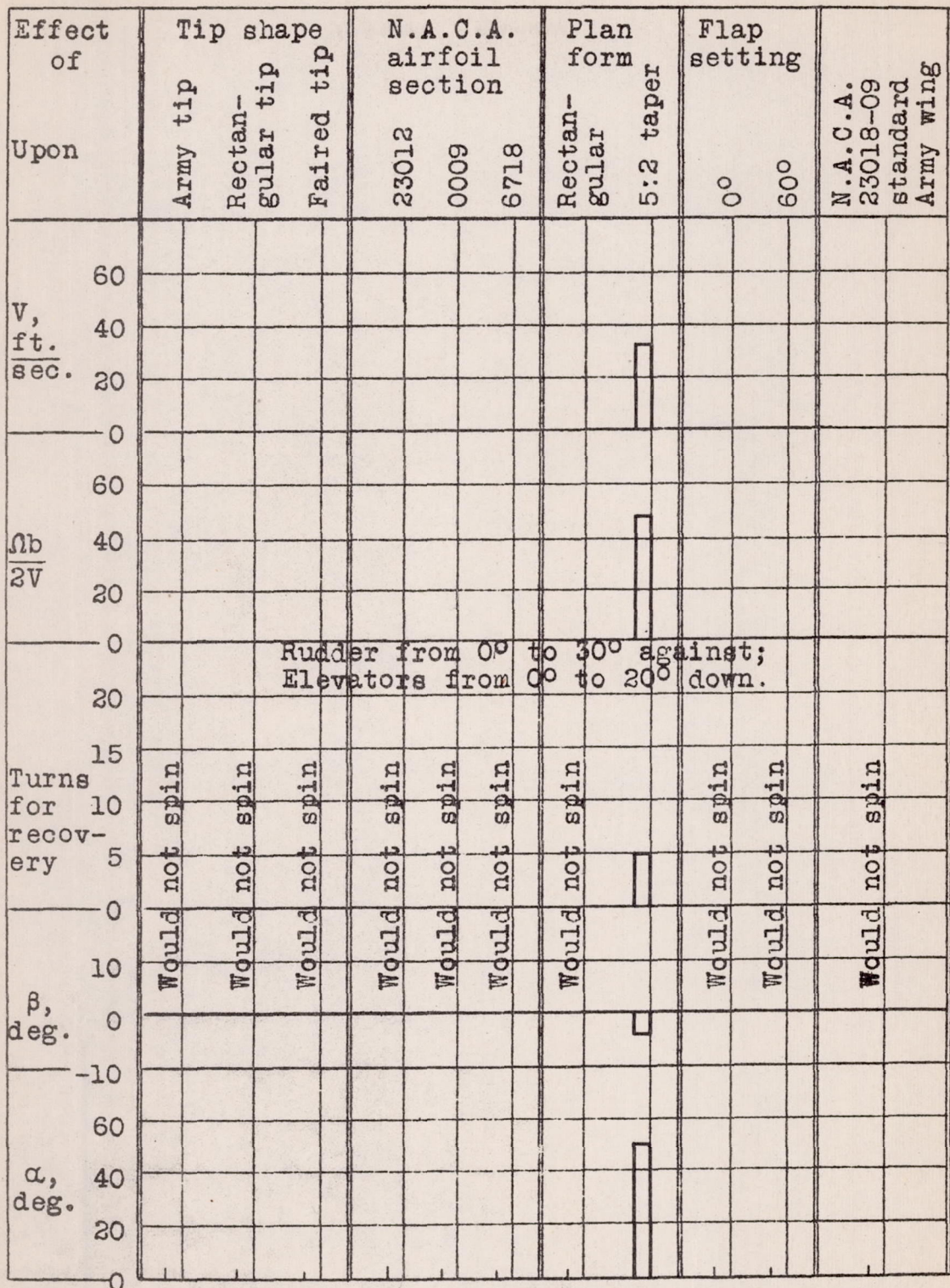

Figure 13 .-The effect of various wings on the spin characteristics. Basic loading condition; tail B, rudder 0° with, elevators 0° , ailerons 0° (Wing has rectangular plan form, Army tips, N.A.C.A.23012 section, except as noted.)

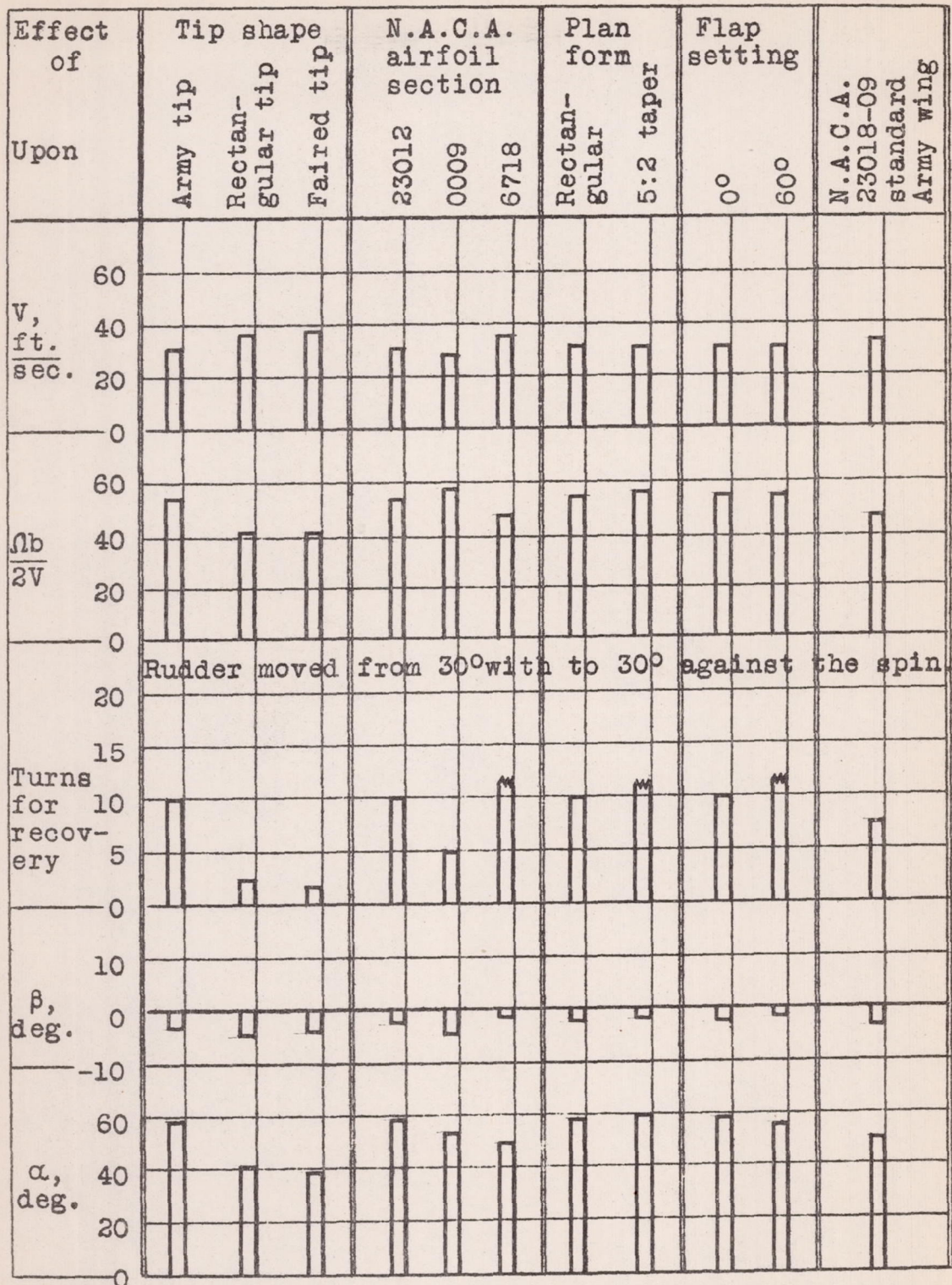

Figure 14 .-The effect of various wings on the spin characteristics. Basic loading condition; tail C, rudder 30° with, elevators 0°, ailerons 0° (Wing has rectangular plan form, Army tips, N.A.C.A.23012 section, except as noted.)

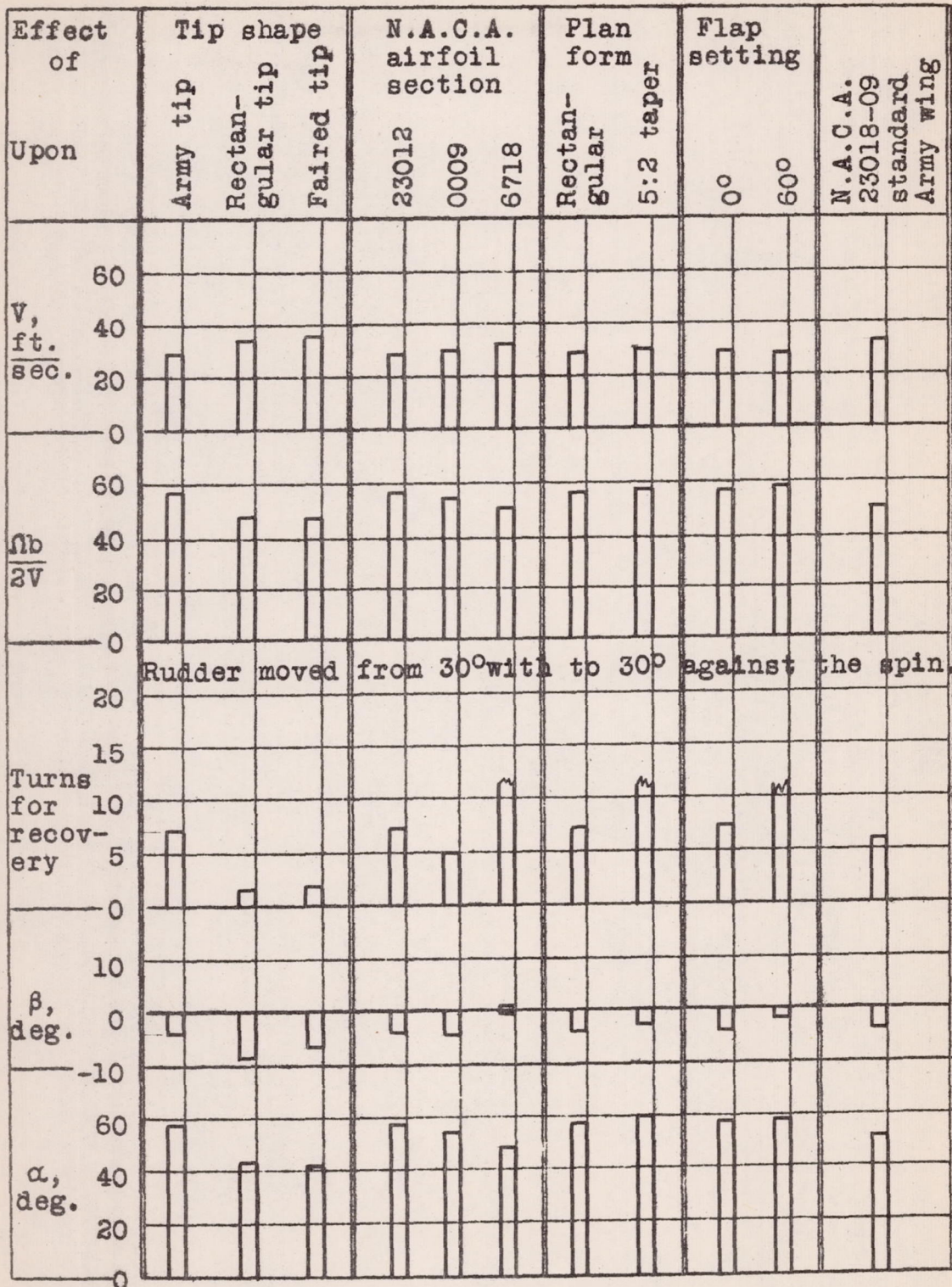

Figure 15 .-The effect of various wings on the spin characteristics. Basic loading condition; tail C, rudder 30° with, elevators 20° down, ailerons 0° (Wing has rectangular plan form, Army tips, N.A.C.A.23012 section, except as noted.)

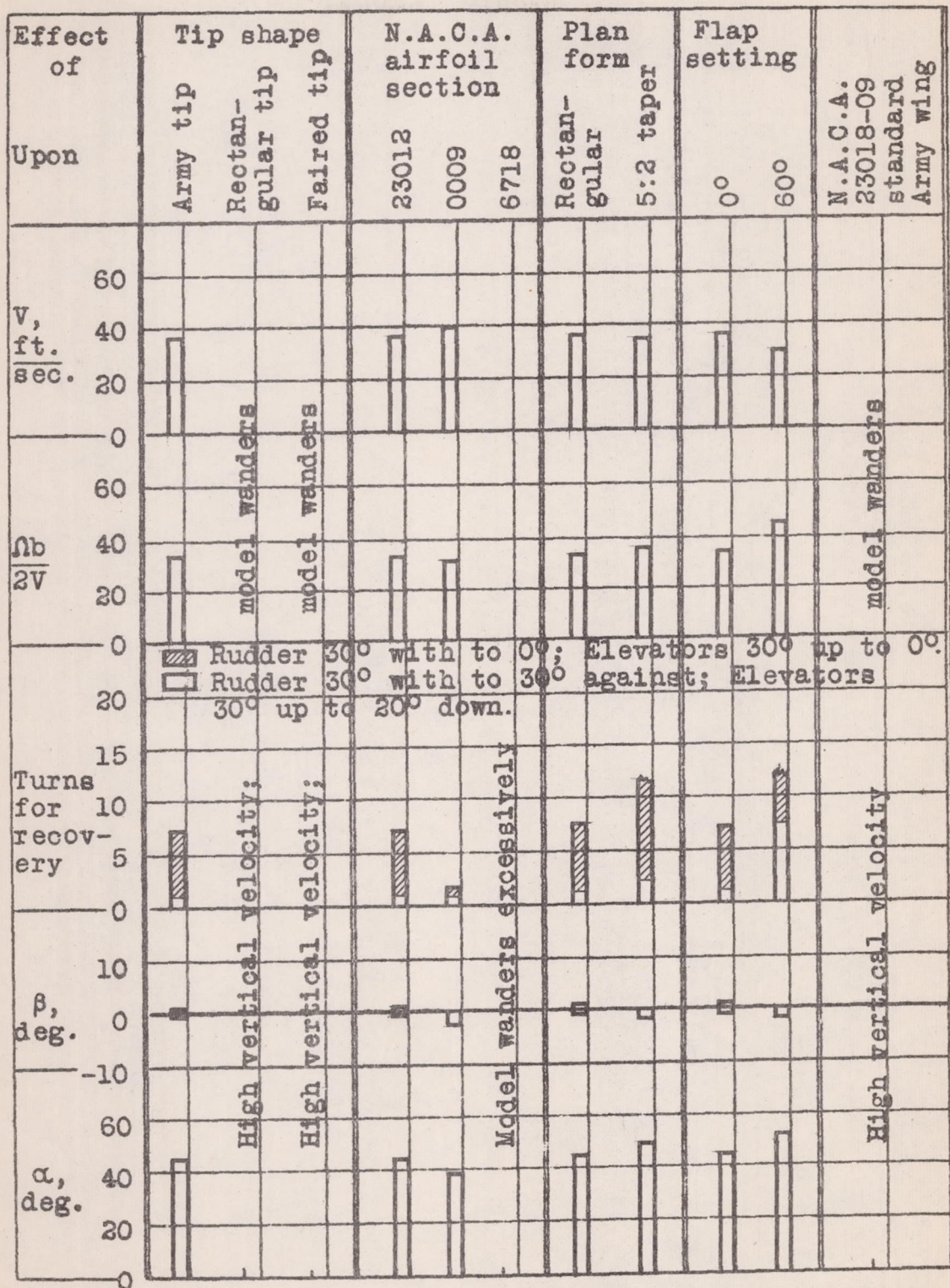

Figure 16 .-The effect of various wings on the spin characteristics. Basic loading condition; tail C, rudder 30° with, elevators 30° up, ailerons 0° (Wing has rectangular plan form, Army tips, N.A.C.A. 23012 section, except as noted.)

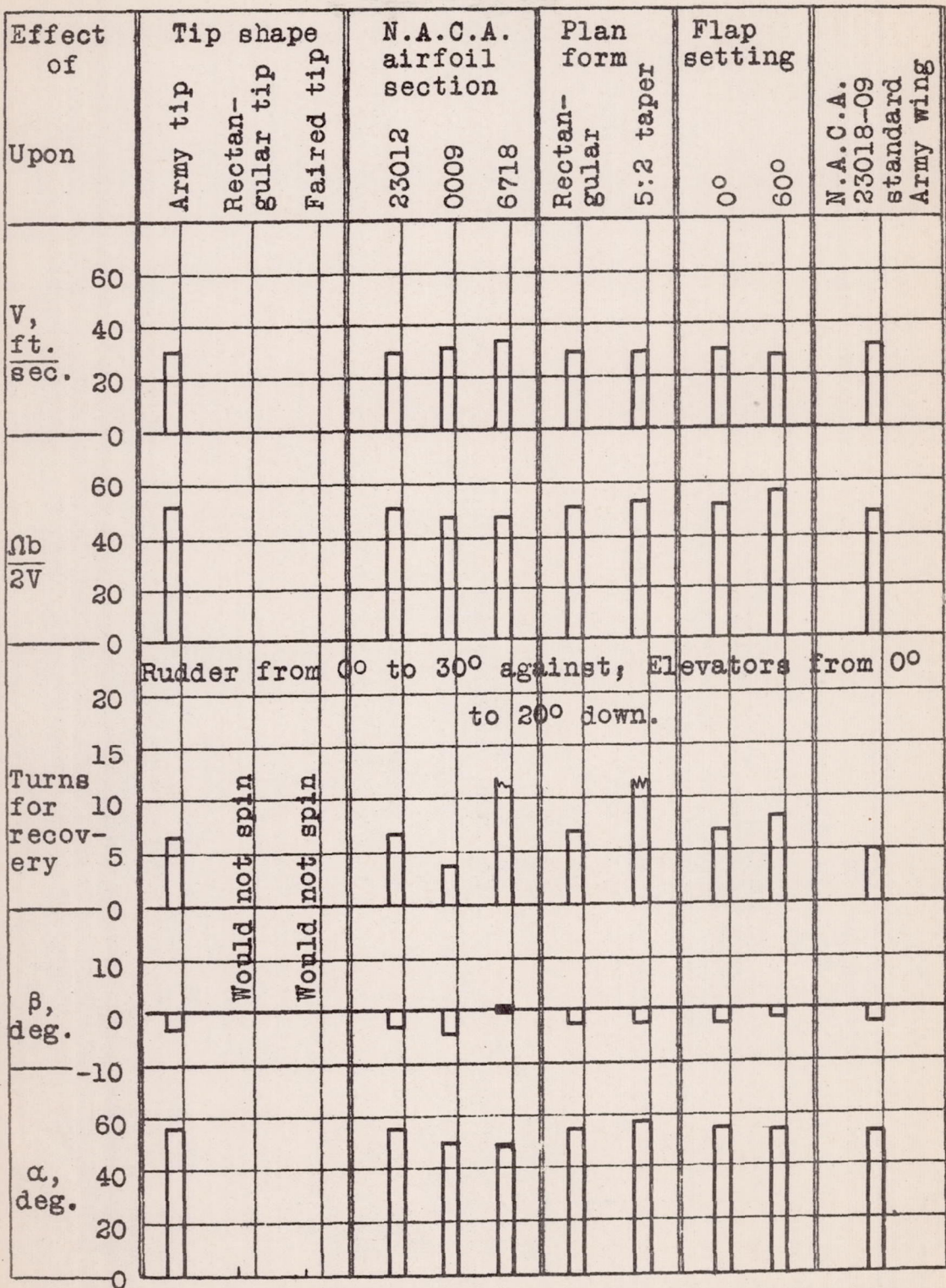

Figure 17 .-The effect of various wings on the spin characteristics. Basic loading condition; tail C, rudder 0° with, elevators 0° , ailerons 0° (Wing has rectangular plan form, Army tips, N.A.C.A.23012 section, except as noted.)