

Y3.N215:6/656

National Advisory Committee

for Aeronautics

1X656

GOVT. DOC.

MAILED

JUL 25 1938

To: Hartford Public Library

TECHNICAL NOTES

NATIONAL ADVISORY COMMITTEE FOR AERONAUTICS

No. 356

HYDRODYNAMIC AND AERODYNAMIC TESTS OF MODELS
OF FLOATS FOR SINGLE-FLOAT SEAPLANES
N.A.C.A. MODELS 41-D, 41-E, 61-A, 73, and 73-A

By J. B. Parkinson and R. O. House
Langley Memorial Aeronautical Laboratory

Washington
July 1938

BUSINESS, SCIENCE
& TECHNOLOGY DEPT.

NATIONAL ADVISORY COMMITTEE FOR AERONAUTICS

TECHNICAL NOTE NO. 656

HYDRODYNAMIC AND AERODYNAMIC TESTS OF MODELS
OF FLOATS FOR SINGLE-FLOAT SEAPLANES

N.A.C.A. MODELS 41-D, 41-E, 61-A, 73, AND 73-A

By J. B. Parkinson and R. O. House

SUMMARY

Tests were made in the N.A.C.A. tank and in the N.A.C.A. 7- by 10-foot wind tunnel of two models of transverse-step floats and three models of pointed-step floats considered to be suitable for use with single-float seaplanes. The models were designed at the N.A.C.A. tank as part of a program having for its object the reduction of the water resistance and spray of single-float seaplanes without reducing the angle of dead rise believed to be necessary for the satisfactory absorption of the shock loads.

The form of N.A.C.A. model 41-D is similar to that of the Navy Mark V float (N.A.C.A. model 41-A) but has more gradual fore-and-aft curvature of the buttock lines near the steps and a lower angle of afterbody keel. N.A.C.A. model 41-E is a modification of model 41-D, the rear step having been eliminated. N.A.C.A. model 61-A has a pointed step with a horizontal afterbody similar to N.A.C.A. model 35-B. N.A.C.A. model 73 is a refinement of the pointed-step form, in which a fairing has been fitted above and behind the step. N.A.C.A. model 73-A is a modification of model 73, the chine being wider and higher near the bow for greater seaworthiness in rough water.

All the models were tested in the N.A.C.A. tank free to trim at one gross load. The results indicated that all the models have less resistance and spray than the model of the Mark V float and that the pointed-step floats are somewhat superior to the transverse-step floats in these respects. Models 41-D, 61-A, and 73 were tested by the general method over a wide range of loads and speeds; the results are presented in the form of curves and charts for use in design calculations.

The aerodynamic drag of the models was determined in the N.A.C.A. 7- by 10-foot wind tunnel at angles of pitch from -10° to 16° . Models 61-A and 73 have the lowest minimum drag coefficient and model 73-A has the highest. The difference between models 41-D and 41-E is negligible.

INTRODUCTION

Tests in the N.A.C.A. tank of models of the Navy Mark V and Mark VI floats for single-float seaplanes and of N.A.C.A. model 35-B under the same conditions of loading are described in reference 1. These tests were the first part of an investigation, undertaken at the request of the Bureau of Aeronautics, Navy Department, to obtain results that could be used to improve the resistance and spray characteristics of single floats without decreasing the angle of dead rise incorporated in the Mark V lines (26° at the keel and $22-1/2^{\circ}$ including flare). The results presented in reference 1 indicate that resistance and spray were adversely affected by the excessive trims assumed at low speeds by the Navy floats and that pointed-step forms with horizontal afterbodies offer some possibility of improvement because of their lower trims.

As a continuation of the investigation, models of several floats were designed for the same service as that of the Mark V float but having certain features suggested by the results of the earlier tank tests. These models were tested in the N.A.C.A. tank to determine their water characteristics and also in the N.A.C.A. 7- by 10-foot wind tunnel to determine their relative aerodynamic drag. The results have been combined in this report so that the various forms may be evaluated from considerations of flight as well as take-off performance.

DESCRIPTION OF MODELS

The lines of the models are shown in figures 1, 2, and 3. Model 41-D (fig. 1) is similar to the Mark V float (N.A.C.A. model 41-A), shown dotted, but the changes in the fore-and-aft curvature of the planing surfaces have been made less abrupt to secure more uniform distribution of the bottom pressures. The design also has a lower angle of afterbody keel for the purpose of reducing the trim

at the hump speed. The forebody buttocks are straighter near the forward step and the short hook forward of the second step found on model 41-A has been replaced by a more gradual hook beginning at station 13. Model 41-E has the same form as model 41-D except that the second step is eliminated by extending the hook back to the tail of the float, resulting in a further reduction in the effective angle of afterbody keel.

In model 61-A (fig. 2) the pointed-step form of N.A.C.A. model 35-B (reference 2) has been adapted to a float form by using a bow with a form similar to that of the Navy Mark VI float (N.A.C.A. model 41-B), a transverse chine flare on the planing bottom, and a rounded deck. It was first tested as model 61 (shown dotted) with a shorter bow similar to that of model 41-D and model 41-A but the extended bow was finally adopted because it was cleaner at very low speeds.

Model 73 (fig. 3) is a further refinement of model 61-A in which the high vertical sides of the pointed step and the deep discontinuity behind the step have been reduced by a suitable fairing. This fairing adds volume to the float and reduces structural discontinuities. A shape that would not impair the hydrodynamic qualities of the pointed-step form was determined from preliminary tests with plasticine fairings on model 61-A. The small vertical side above the chines along the step was found to be necessary to keep the fairing from being wetted at intermediate planing speeds and light loads. The plan form of model 73 was made wider near the tail than that of model 61-A in order to secure more buoyancy aft and more lift from the afterbody at low speeds on the water, although the wider form entails some sacrifice in resistance characteristics at high speeds and light loads because of afterbody interference.

Model 73-A (shown dotted on fig. 3) is a modification of model 73 in which the chine forward of station 6 has been moved upward and outward and a definite horizontal flat has been incorporated in the sections at the chines. This form of bow is considered by the Bureau of Aeronautics to be more seaworthy in rough water than the bow of model 73.

It should be noted that the greater over-all length of the pointed-step floats is a result of the longer bows

used rather than of an increase in the size of the planing surfaces.

The fore-and-aft positions of the center of gravity shown were determined from considerations of trim at low speeds. The height of the center of gravity from the keel for all the models was made the same as that of the original Navy model (model 41-A).

The offsets of the models are given in tables I, II, III, and IV. The important characteristics of their forms, including those of model 41-A are as follows:

N.A.C.A. model	(Mark V) 41-A	41-D	41-E	61-A	73	73-A
Length, in.	76.21	76.53	77.06	80.40	80.40	80.40
Beam, in.	12.00	12.00	12.00	12.00	12.00	12.00
Depth, in.	10.29	10.29	10.29	10.29	10.29	10.29
Angle of dead rise: at keel, deg.	26.0	26.0	26.0	26.0	26.0	26.0
including flare, deg.	22.5	22.5	22.5	22.5	22.5	22.5
Center-of-gravity location:						
above keel, in.	24.43	24.43	24.43	24.43	24.43	24.43
aft of bow, in.	37.37	36.00	36.00	39.45	39.45	39.45
Total volume, cu. in.	4,430	4,690	4,695	4,975	5,480	5,446
Draft at rest, in. (88.6-lb. load)	6.4	6.2	6.2	6.7	6.1	6.2
Trim at rest, deg. (88.6-lb. load)	3.4	3.1	3.0	3.1	2.1	1.9

All the models were made of laminated wood and smoothly finished with gray pigmented varnish.

HYDRODYNAMIC TESTS

Test Procedure

The hydrodynamic tests were made in the N.A.C.A. tank (reference 3) using the towing gear described in reference 4. The models were first tested free to trim at one gross load in order to observe their general behavior and to determine a suitable fore-and-aft position for the center of gravity of the seaplane. Fixed-trim tests were then made by the general method over a wide range of operating conditions in order to obtain data for design calculations.

In the free-to-trim tests, the models were pivoted at a point corresponding to the assumed center of gravity of the seaplane and balanced about this point so that the trim was not affected by a gravity moment. The results then closely represent the characteristics of the seaplane with no control from the pilot because the thrust moment of a float seaplane and the aerodynamic moments at low speeds are both quite small. Several fore-and-aft positions of the pivot were tried in each case to find the best compromise for operation at low speeds with little or no control from the pilot. The final positions chosen are shown in figures 1, 2, and 3. The conditions assumed for these free-to-trim tests were the same as for the earlier tests (reference 1) of model 41-A, as follows:

	Full-size	Model
Gross load, lb.	3,800	88.6
Get-away speed, f.p.s.	89.5	47.8
Linear ratio, full-size to model	3.50	

The wing lift was simulated by a hydrofoil device (reference 4) set to produce a lift equal to the model gross load at the model get-away speed. At intermediate speeds, the lift was measured by a dynamometer inserted in the lift wire. Resistance and trim were measured during runs at constant speed.

In the fixed-trim tests, the resistance, the trimming moment, and the draft of models 41-D, 61-A, and 73 were measured at constant speed for all combinations of trim,

load, and speed thought to be necessary. The static drafts and trimming moments of these models were measured for the same range of loadings in order to obtain data with which to determine load water lines and longitudinal stability for various designs. In the case of model 41-E, a limited amount of data was obtained merely to show the effect of the altered afterbody under representative conditions. Fixed-trim tests of model 73-A were not included in the present program because the free-to-trim tests showed its performance to be essentially the same as that of model 73 under the smooth-water conditions existing in the tank.

Results and Discussion

Free-to-trim tests.— The results of the free-to-trim tests of models 41-D, 41-E, 61-A, and 73 are plotted in figure 4, together with corresponding data from the tests of model 41-A (Mark V float). For clearness, the results of the test of model 73-A are not included in figure 4 but are compared with those of model 73 in figure 5. In figures 4 and 5 the resistance is the water resistance plus the small air drag of the model, and the trim τ is the angle between the base line of the model and the horizontal. The load is the model gross load minus the lift from the hydrofoil device. In the test of model 73-A, the load curve of the previous models was not exactly reproduced, the difference at the hump speed being about 2 percent as indicated in figure 5.

The hump resistance of each of the five floats is lower than that of model 41-A, partly because of the lower trim at which they run. The pointed-step floats have higher maximum resistance but lower resistance at speeds above that of maximum resistance than do the transverse-step floats, models 41-D and 41-E. The bow of model 73-A has slightly higher resistance than that of model 73. If the difference in test loads were taken into account, the difference in resistance at the same load would also be slightly greater than that shown in figure 5. Model 73 has the lowest average resistance through the low-speed range.

The trims of all the models are likewise lower than that of model 41-A. Model 41-E trims lower than model 41-D because of its small increase in afterbody planing surface and its lower effective angle of afterbody keel. Model 73 trims lower than model 61-A because of its fuller

plan form aft. The trims of models 73 and 73-A are essentially the same.

Spray characteristics.— The spray characteristics of the various models are more difficult to evaluate but the general impression gained during the tests was that all the models ran cleaner than model 41-A and that the pointed-step forms were superior to the transverse-step forms. The objectionable flow over the afterdeck at very low speeds, noted on model 41-A in reference 1, was reduced when the trim was reduced and practically disappeared in the case of models 73 and 73-A. The height and volume of the roach or jet of water aft of the tail were less in all cases than that of model 41-A. The roach formed by the pointed-step floats occurred later than that of the transverse-step floats and appeared smaller. The extended bow of models 61-A and 73 appeared to run cleaner even for smooth-water conditions than the bluff bows of models 41-A, 41-D, and 41-E. The bow of model 73-A ran cleanest, probably because of the pronounced flat at the chines in the forward sections. The cleaner forms of bow, however, require greater over-all length of float and hence a small increase in the structural weight. Typical photographs of spray, taken during the free-to-trim tests, are shown in figures 6 to 10.

General tests at fixed trim.— The results of the tests at fixed trim are plotted in figures 11 to 29. The figure numbers are given in the following table:

Trim, τ (deg.)	Figure numbers						
	3	5	7	9	11	13	15
Model 41-D	11	12	13	14	15	16	17
Model 41-E		12	13	14	15	16	
Model 61-A	18	19	20	21	22	23	
Model 73	24	25	26	27	28	29	

The nondimensional coefficients are those generally used for the results of tests of flying-boat hulls and are defined as follows:

$$\text{Resistance coefficient, } C_R = \frac{R}{wb^3}$$

$$\text{Load coefficient, } C_\Delta = \frac{\Delta}{wb^3}$$

$$\text{Trimming-moment coefficient, } C_M = \frac{M}{wb^4}$$

$$\text{Draft coefficient, } C_D = \frac{d}{b}$$

$$\text{Speed coefficient, } C_V = \frac{V}{\sqrt{gb}}$$

where R is the water resistance plus the air drag of the float, lb.

Δ , the load on the float, lb.

M , the trimming moment of the float, lb.-ft.

d , the distance of the keel at the main step below the free water surface, ft.

V , the speed, f.p.s.

b , the maximum beam of the float, ft.

w , the specific weight of water, lb./cu. ft.

g , the acceleration of gravity, 32.2 ft./sec.²

The moments are referred to the center-of-gravity positions shown in figures 1, 2, and 3. Moments tending to raise the bow are considered positive.

The coefficients are based on the maximum beam of the float as the characteristic dimension rather than on the cube root of the total volume in view of the fact that the form above the chines has no effect on the hydrodynamic qualities except at the lowest speeds and may be considerably varied to suit surplus buoyancy requirements for specific designs. When the whole form of the float is considered fixed, as in the aerodynamic tests described later, a system of coefficients based on the total volume is more useful for comparative purposes because this volume is usually fixed in relation to the gross weight of the seaplane regardless of the shape of the float.

The effect of the difference in the form of the afterbody of models 41-D and 41-E is shown in figures 12 to 16. At 5° trim, model 41-E has higher resistance at high speeds because of greater afterbody interference with flow from the forebody. At 7° trim the spray from the forebody apparently clears the afterbody, as no appreciable increase in resistance is found. At higher trims and at low speeds, model 41-E has slightly lower resistance, lower positive trimming moments, and less draft because of the greater lift of its afterbody.

At 9° trim, model 41-D has two regimes for load coefficients 0.3, 0.15, and 0.075 (fig. 14). The upper curves for these load coefficients were obtained with the forebody in the water and spray striking the afterbody. The lower curves were obtained with the forward step clear of the water and with the load borne only by the afterbody. Within the range shown double-valued, the model would be stable at constant speed in either position. Under the same conditions, models 61-A and 73 ran only on the afterbody, even after the forebody was pushed down into the water by hand at the beginning of the run (figs. 21 and 27).

The trimming-moment and draft coefficients at rest of models 41-D, 61-A, and 73 are plotted against load coefficient in figures 30, 31, and 32. Similar data for models 41-E and 73-A have not been included as the data for models 41-D and 73, respectively, may be used with sufficient accuracy. From these figures, the curves of trimming moment and draft against trim may be determined for various sizes and loadings. The corresponding curves for other positions of the center of gravity may also be determined by the use of the proper moment correction.

Data at best trim and at zero trimming moment. - Cross plots of resistance and moment coefficients against trim at various selected speed coefficients were prepared from the general test data for models 41-D, 61-A, and 73 to provide data for comparisons and design calculations. From these cross plots, curves of resistance coefficient and trim at zero trimming moment against speed coefficient (figs. 33 to 35) and curves of resistance coefficient, trim, and trimming-moment coefficient at best trim (trim of lowest resistance) against speed coefficient (figs. 36 to 38) were obtained. Charts for the determination of resistance at zero trimming moment and at best trim are given in figures 39 to 44 in the form of curves against load coefficient. The corresponding data for models 41-E

and 73-A have not been included because of the small differences between their characteristics and those of models 41-D and 73, respectively. The use of the data for various take-off calculations is outlined in reference 1.

In the foregoing data, the best trim is considered to be the trim that results in lowest resistance when the forebody is in contact with the water, although lower resistance may be obtained at high speeds and light loads when the forebody is clear of the water. The condition of the forebody clear of the water results, of course, in higher negative trimming moments and should therefore be the subject of a separate calculation in which the control available from the elevators is considered.

The resistance coefficients of models 41-A, 41-D, 61-A, and 73 at various load coefficients are compared in figure 45. The use of these coefficients provides a comparison on the basis of equal beams; hence, it follows that in this comparison the pointed-step models having higher length-beam ratios are longer and have more total buoyancy than model 41-A. At zero trimming moment, the order of merit of the models is the same as indicated in the results of the specific free-to-trim tests. This order of merit persists and is found even at heavier load coefficients, model 73 having the lowest average resistance and model 41-A the highest. At best trim, model 73 has the lowest low-speed resistance. The differences at intermediate planing speeds are small. At high speeds and light loads ($C_{\Delta} = 0.15$), model 41-D has the same resistance as model 41-A and the pointed-step models have a lower resistance than either of the others. Model 61-A has less resistance in this region than model 73 because of its finer afterbody.

AERODYNAMIC TESTS

Test Procedure

The aerodynamic tests of the models were made in the N.A.C.A. 7- by 10-foot wind tunnel (reference 5) with a closed test section. The air drag was measured at a dynamic pressure of 16.37 pounds per square foot, corresponding to an air speed of 80 miles per hour at standard sea-level atmospheric conditions. The range of pitch angle was from -10° to 16° measured at 2° intervals from the base line.

The models were mounted inverted on the standard single-spindle support in the center of the air stream. A small part of the spindle being exposed to the air, tests were also made with a dummy support in place to obtain the tare drag. Figure 46 shows model 73-A mounted in the tunnel.

Results and Discussion

The data were reduced to coefficient form by means of the relation

$$C_D = \frac{D}{q \text{ vol}^{2/3}}$$

where C_D is the drag coefficient.
 D , drag of float.
 q , dynamic pressure $(\frac{1}{2} \rho V^2)$.
 vol , volume of float.

The drag coefficient is based on volume rather than area because the volume of a float is the more important variable, being determined largely by the weight of the seaplane.

The values of the drag coefficient are plotted against pitch angle in figure 47. The pitch angle was measured from the base line in figure 47(a) and from the angle for minimum drag in figure 47(b). Models 61-A and 73 have the lowest minimum drag and model 73-A has the highest.

The minimum drag coefficient of each model and the angle of pitch at which it occurs are given in the following table.

N.A.C.A. model	(Volume) ^{2/3} (ft) ²	$C_{D \text{ min}}$	Pitch angle (deg.)
41-D	1.947	0.0373	0.5
41-E	1.946	.0370	0
61-A	2.024	.0325	-4
73	2.158	.0330	-1
73-A	2.150	.0400	0

Tests of streamlined bodies of different cross-sectional shape have shown that when the intersections of the surfaces are placed parallel to the air flow the drag caused by sharp or by faired intersections is about the same. When the intersections are placed obliquely to the air stream, however, the drag caused by the sharp intersection is much greater than that caused by the faired intersections (reference 6). The drag of a float would therefore be expected to increase as the angles of keel, chine, deck, and step increase relative to the direction of the air flow.

The effect on drag of eliminating the second step is negligible, as is shown by the curves of models 41-D and 41-E (fig. 47).

The drag is less for model 61-A than for model 41-D at angles of pitch, measured from the base line, below 1° and above 11° and is less at all angles measured from the angle for minimum drag. Part of the difference in drag of the two floats is probably due to the manner in which the air flow is affected by the different angles of afterbody keel of model 61-A and model 41-D.

The drag caused by the transverse step of model 41-D is probably about the same as that caused by the pointed step of model 61-A, for it has been shown that the difference in drag due to pointed and transverse steps is not very great (reference 7). The bluff bow of model 41-D would be expected to affect the drag adversely; the extended bow of model 61-A would be preferable.

The faired step of model 73 adds less drag than the unfaired step of model 61-A for the range of pitch angles from -10° to 7° except at the angle for minimum drag.

At minimum drag the air flow is probably parallel to the cove; consequently, fairing would have very little effect. At all other angles of pitch, the cove is no longer parallel to the free air stream and fairing would be expected to reduce the drag.

The wider afterbody of model 73 probably causes the increase in drag above an angle of pitch of 7° because the air is then flowing at an appreciable angle to the longitudinal direction of the float. The drag at angles of pitch higher than 7° would be unimportant, inasmuch as floats of this type are rarely flown at these attitudes.

Model 73-A is aerodynamically the poorest of the floats tested. Its high drag apparently is caused by the form of its bow, which has higher and wider chines than those of the other models tested.

The order of merit of the floats with respect to low aerodynamic drag is, in general, models 73, 61-A, 41-D, 41-E, and 73-A. The angle to the flight path at cruising speed is the determining factor in the choice of a float, however, and if this angle is known, figure 47(a) may be consulted to find the best float on the aerodynamic basis for the specific condition.

The results of the tests of these models give further evidence of the importance of keeping sharp intersections parallel to the direction of air flow. Making the bow as fine as possible appears to be a way of reducing the bad effects of the chine at the bow. It appears that the angle of minimum drag may be changed by altering the angle of the afterbody keel. When this modification is practicable, the choice of the best angle of afterbody keel might result in an appreciable reduction in drag in the flying range.

CONCLUSIONS

The most suitable form of float for a given design of float seaplane depends on the relative importance of requirements that often conflict, such as low water resistance, low aerodynamic drag, good seaworthiness, low structural weight, and economy of construction. In view of these considerations, the following conclusions are drawn regarding the float forms dealt with in this report:

1. Two of the pointed-step forms, models 61-A and 73, have lower water resistance and lower aerodynamic drag than the transverse-step forms, models 41-D and 41-E.

2. The fairing of the pointed step had only a small effect on the water resistance and aerodynamic drag.

3. The bow of model 73-A will be the most seaworthy in rough water but it has high aerodynamic drag. The bow of models 61-A and 73 will be more seaworthy than the bluff form of models 41-D and 41-E.

Langley Memorial Aeronautical Laboratory,
National Advisory Committee for Aeronautics,
Langley Field, Va., May 4, 1938.

REFERENCES

1. Parkinson, J. B.: Tank Tests of Models of Floats for Single-Float Seaplanes - First Series. T.N. No. 563, N.A.C.A., 1936.
2. Dawson, John R.: Tank Tests of Three Models of Flying-Boat Hulls of the Pointed-Step Type with Different Angles of Dead Rise - N.A.C.A. Model 35 Series. T.N. No. 551, N.A.C.A., 1936.
3. Truscott, Starr: The N.A.C.A. Tank - A High-Speed Towing Basin for Testing Models of Seaplane Floats. T.R. No. 470, N.A.C.A., 1933.
4. Allison, John M.: Tank Tests of a Model of the Hull of the Navy PB-1 Flying Boat - N.A.C.A. Model 52. T.N. No. 576, N.A.C.A., 1936.
5. Wenzinger, Carl J., and Harris, Thomas A.: Tests of an N.A.C.A. 23012 Airfoil with Various Arrangements of Slotted Flaps in the Closed-Throat 7- by 10-Foot Wind Tunnel. T.R. No. (to be published), N.A.C.A., 1938.
6. Wieselsberger, C.: Air Forces Exerted on Streamlined Bodies with Round or Square Cross-Sections, when Placed Obliquely to the Airstream. T.M. No. 267, N.A.C.A., 1924.
7. Hartman, Edwin P.: The Aerodynamic Drag of Flying-Boat Hull Models as Measured in the N.A.C.A. 20-Foot Wind Tunnel - I. T.N. No. 525, N.A.C.A., 1935.

TABLE I
 OFFSETS FOR N.A.C.A. MODEL 41-D SINGLE FLOAT (INCHES)

Station	Dis- tance from F.P.	Distance from base line								Half-breadth				Deck radius		
		Keel	B1 1.00 ^a	B2 2.00	B3 3.00	B4 4.00	B5 5.00	Chine	Deck	Chine	WL1 8.57 ^b	WL2 6.86	WL3 5.14		WL4 3.43	
F.P.	0	2.50							2.50	2.50	tang to F.P.					
1/4	1.07	5.62	4.16	3.39					3.18	1.36	2.56		0.27	1.95	2.71	
1/2	2.15	6.82	5.40	4.42	3.87				3.78	1.00	3.42		1.23		3.49	
1	4.30	8.23	6.97	5.96	5.19	4.82			4.79	.59	4.36		0.86	3.11	4.36	
1-1/2	6.45	9.05	7.97	7.00	6.23	5.73			5.57	.35	4.87	0.43	2.17		4.87	
2	8.60	9.55	8.57	7.71	6.99	6.44	6.19	6.18	.22	5.21	1.00	3.21			5.21	
3	12.90	10.07	9.29	8.55	7.92	7.39	7.06	7.01	.07	5.64	1.97				5.64	
4	17.20	10.26	9.62	9.00	8.43	7.94	7.59	7.49	.02	5.86	2.75				5.86	
5	21.50	10.29	9.76	9.23	8.72	8.24	7.86	7.73	0	5.97	3.32				5.97	
6 to 10F	25.80 43.00	10.29	←—————→				8.34	7.95	7.81	↑	6.00					6.00
10A	43.00	9.36	←—————→						6.44							
11	46.32	8.89	←—————→						6.01	↓	5.90					5.90
11-1/2	50.16	8.35	←—————→						5.59	0	5.66					5.66
12	54.00	7.82	←—————→						5.26	.01	5.25					5.25
12-1/2	57.84	7.28	←—————→						4.98	.04	4.72					4.72
13	61.68	6.83	←—————→						4.86	.15	4.05					4.05
13-1/2	65.52	6.51	←—————→						4.92	.31	3.27					3.27
14	69.36	6.34	←—————→						5.18	.54	2.39					2.39
F 15		6.30							5.48							1.69
A	72.07	5.44	←—————→						4.62	.71	1.69					1.69
16	74.61	4.90	←—————→						4.41	.97	1.00					1.00
A.P.	76.53	4.49							4.49		0.56 Rad.					

ADDITIONAL OFFSETS FOR MODEL 41-E

16	74.61	6.35	←—————→				5.86	1.00							
A.P.	76.53	6.43	←—————→				6.22	.44							

^aDistance from center line (plane of symmetry) to buttock (B).

^bDistance from base line to water line (WL).

TABLE II

OFFSETS FOR N.A.C.A. MODEL 61-A SINGLE FLOAT (INCHES)

Station	Dis- tance from F.P.	Distance from base line										Half-breadths					Deck radius				
		Keel	B1 1.00 ^a	B2 2.00	B3 3.00	B4 4.00	B5 5.00	Main chine	Cove	Upper chine	Deck	Main chine & cove	Upper chine	WL1 8.57 ^b	WL2 6.86	WL3 5.14		WL4 3.43	WL5 1.71		
F.P.	0	1.71									1.71										
a	1.00	4.43	1.03 2.79	2.12 2.23							2.22						0.49	1.76	See upper offsets		
b	3.00	6.36	.52 4.74	1.10 3.74	2.49 3.29						3.20				0.71	2.51	2.54				
1/2	5.15	7.60	.29 6.21	.71 5.13	1.59 4.41						4.13				0.52	1.98	3.90	3.11			
1	7.30	8.46	7.27	6.23	5.46	5.01					4.94				1.37	3.58	4.38	3.56		4.40	
1-1/2	9.45	9.08	8.00	7.07	6.30	5.79					5.62				0.46	2.25	4.91	4.78		3.97	4.43
2	11.60	9.55	8.57	7.71	6.99	6.44	6.19	6.18				↑			1.00	3.21	5.21	5.10		4.29	↑
3	15.90	10.07	9.29	8.55	7.92	7.39	7.06	7.01				↑			1.97						
4	20.20	10.26	9.62	9.00	8.43	7.94	7.59	7.49				↑			2.75						
5	24.50	10.29	9.76	9.23	8.72	8.24	7.86	7.73				↑			3.32						
6	28.80	↑	←————→		8.34	7.95	7.81	4.43	4.43			6.00									
7	33.10	↑	←————→		↑	7.81	4.47				7.81	4.47	↑								
8	37.40	↑	←————→		↓	7.95	7.86	4.69			7.86	4.69	↓								
9	41.70	↑	←————→		8.34		8.10	5.12	4.43			8.10	5.12	↓							
10	46.00	↑	←————→				8.73	5.79	4.47			8.73	5.79								
11	50.30	↑	←————→				9.64	6.70	4.61			9.64	6.70								
11-1/2 ^F		10.29	←————→				10.19	7.25				10.19	7.25								
11-1/2 ^A	52.45	7.35	←————→						4.70					.20	5.44						
12	54.60	↑	←————→						4.81					5.20							
13	58.90	↑	←————→						5.09	0				4.64					4.43		
14	63.20	↑	.20	.69	1.65										3.97	3.80	3.05				
15	67.50	↑	.39	1.17	3.56										3.20	2.97	2.37				
16	71.80	↑	.75	2.95											2.32	2.09	1.67				
17	76.10	↑	2.09												1.34	1.17	.95				
A.P.	80.40	7.35	←————→						7.35					.57 Rad.							

^aDistance from center line (plane of symmetry) to buttock (B). ^bDistance from base line to water line (WL).

TABLE III

OFFSETS FOR N.A.C.A. MODEL 73 SINGLE FLOAT (INCHES)

Station	Distance from F.P.	Distance from base line										Half-breadths						Deck radius	
		Keel	B1 1.00 ^a	B2 2.00	B3 3.00	B4 4.00	B5 5.00	Main chine	Cove	Upper chine	Deck	Main chine & cove	WL1 8.57 ^b	WL2 6.86	WL3 5.14	WL4 3.43	WL5 1.71		Upper chine
F.P.	0	1.65						1.65			1.65	0							
a	1.00		0.96	1.94															
		4.45	2.85	2.27				2.23			.66	2.15				0.53	1.85		
b	3.00		.47	1.00	2.07														
		6.38	4.72	3.77	3.32			3.24			.29	3.48			0.68	2.65	2.75		See upper offsets
1/2	5.15		.20	.59	1.31	2.83													
		7.64	6.14	5.13	4.49	4.21		4.19			.12	4.29		0.47	1.99	4.16	3.37		
1	7.30	8.50	7.17	6.18	5.51	5.10		4.99			.03	4.86		1.30	3.84				4.43
1-1/2	9.45	9.11	7.96	7.03	6.32	5.85	5.66	5.65			0	5.26	0.45	2.21					
2	11.60	9.55	8.55	7.68	6.97	6.47	6.23	6.20			↑	5.55	.97	3.21					
3	15.90	10.06	9.31	8.57	7.92	7.39	7.08	7.03				5.87	2.00						
4	20.20	10.24	←→	9.06	8.47	7.97	7.64	7.52				5.98	2.83						
5	24.50	10.29	←	→	8.76	8.26	7.88	7.75				6.00	3.32						
6	28.80	↑	←	→	8.34	7.95	7.81	7.56				6.00	3.53						6.00
7	33.10	←	→	↑	↓	7.81	7.56					5.90	5.93	5.99					↑
8	37.40	←	→	↓	7.95	7.84	7.59					5.47	5.73	5.98					↓
9	41.70	←	→	8.34		7.35						4.64	5.33	5.94					↓
						8.06	7.81												6.00
10	46.00	←	→	7.63	6.43							3.27	4.67	5.78					5.99
						8.69	8.44	4.43											
11	50.30	←	→	6.63	5.62							1.24	2.08	3.80	5.45				5.90
		↓				9.68	9.43	4.48											
11-1/2	52.45	10.29						10.29	10.04										
		10.04	8.92	7.99	7.09	6.21	5.32			4.52		0	1.37	3.22	5.20				5.83
12	54.60	8.96	←	→								4.57							5.73
12-1/2	56.75	8.19	←	→								4.64							5.57
13	58.90	7.71	←	→								4.74							5.36
14	63.20	7.35	←	→								4.99							4.85
																			4.43
15	67.50	↑	.14	.55	1.37	3.43								4.12	4.00	3.27	4.12		
			←	→															
16	71.80	←	.30	1.05	3.20									3.15	3.04	2.47	3.15		See upper offsets
			←	→															
17	76.10	←	.65											1.94	1.84	1.51	1.94		
			←	→															
17-1/2	78.25	↓	1.71								↓	0			1.20	1.16	1.00	1.20	
			←	→															
A.P.	80.40	7.35									7.35	0.57 Rad.		0.57 Rad.	Constant ←→	0.57 Rad.			

^aDistance from center line (plane of symmetry) to buttock (B). ^bDistance from base line to water line (WL).

TABLE IV

OFFSETS FOR BOW OF MODEL 73-A SINGLE FLOAT (INCHES)

Sta- tion	Dis- tance from F.P.	Distance from base line									Half-breadth						Deck radius	
		Keel	B1 1.00 ^a	B2 2.00	B3 3.00	B4 4.00	B5 5.00	Tan- gency of flat	Chine	Deck	Tan- gency of flat	Chine	WL 1 8.57 ^b	WL 2 6.86	WL 3 5.14	WL 4 3.43		WL 5 1.71
F.P.	0	0.45							0.45	0.45		0						
(a)	1.00	3.87	1.73	1.09				1.07	1.07	.04	2.22	2.72			0.14	1.02	4.11	
(b)	3.00	6.19	4.26	3.03	2.41	2.23		2.23	2.23	.00	3.84	4.34		0.50	1.61	4.43		
1/2	5.15	7.61	5.93	4.68	3.87	3.42	3.34	3.34	3.34	↑	4.64	5.14	0.43	1.59	3.97	↑		
1	7.30	8.51	7.05	5.90	5.07	4.52	4.31	4.31	4.31	↑	5.06	5.56	1.15	2.89		↑		
1-1/2	9.45	9.13	7.88	6.82	6.02	5.45	5.16	5.14	5.14	↑	5.31	5.81	0.43	1.96	5.31			
2	11.60	9.54	8.49	7.55	6.77	6.22	5.90	5.84	5.84	↑	5.44	5.94	.91	2.86				
3	15.90	10.04	9.26	8.52	7.83	7.28	6.93	6.87	6.87	↑	5.50	6.00	1.92					
4	20.20	10.25	↔	9.02	8.43	7.90	7.54		7.44	↓		↑	2.75					
5	24.50	10.29	↔ straight	↔	8.75	8.22	7.85		7.72	.00		↓	6.00	3.31			4.43	

Offsets station 6 and aft same as those of model 73 (table III).

^aDistance from center line (plane of symmetry) to buttock (B).

^bDistance from base line to water line (WL).

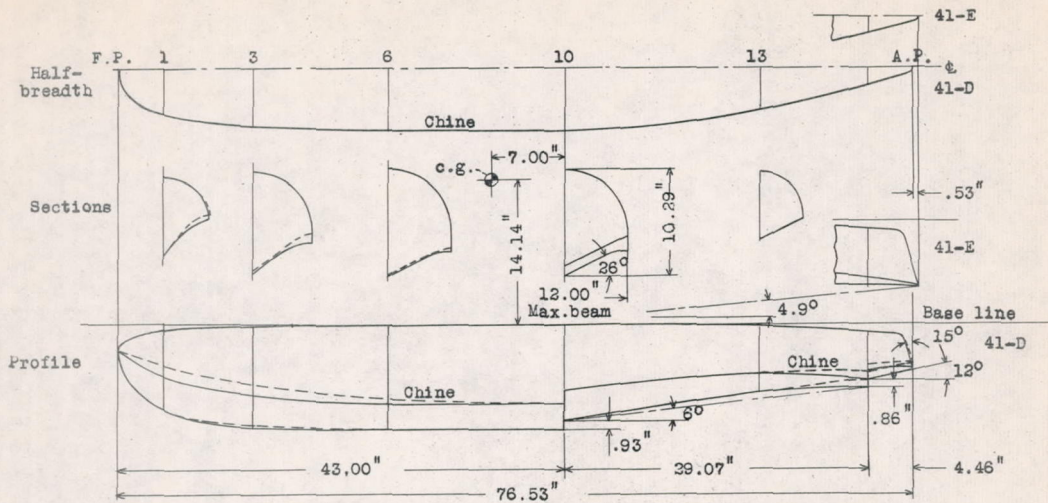

Figure 1.- Lines of model 41-D and model 41-E. Model 41-A (Navy Mark V) shown dotted.

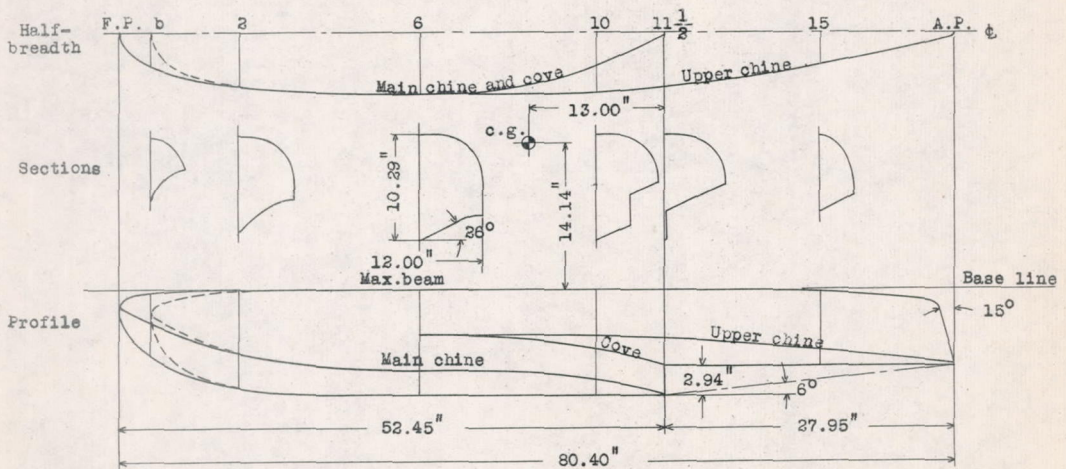

Figure 2.- Lines of model 61-A. Model 61 shown dotted.

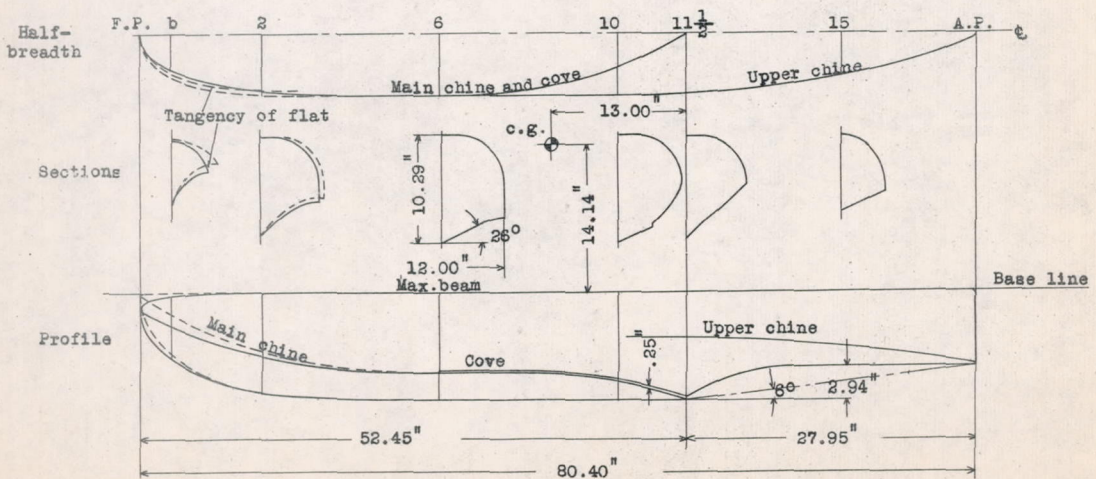

Figure 3.- Lines of model 73. Model 73-A shown dotted.

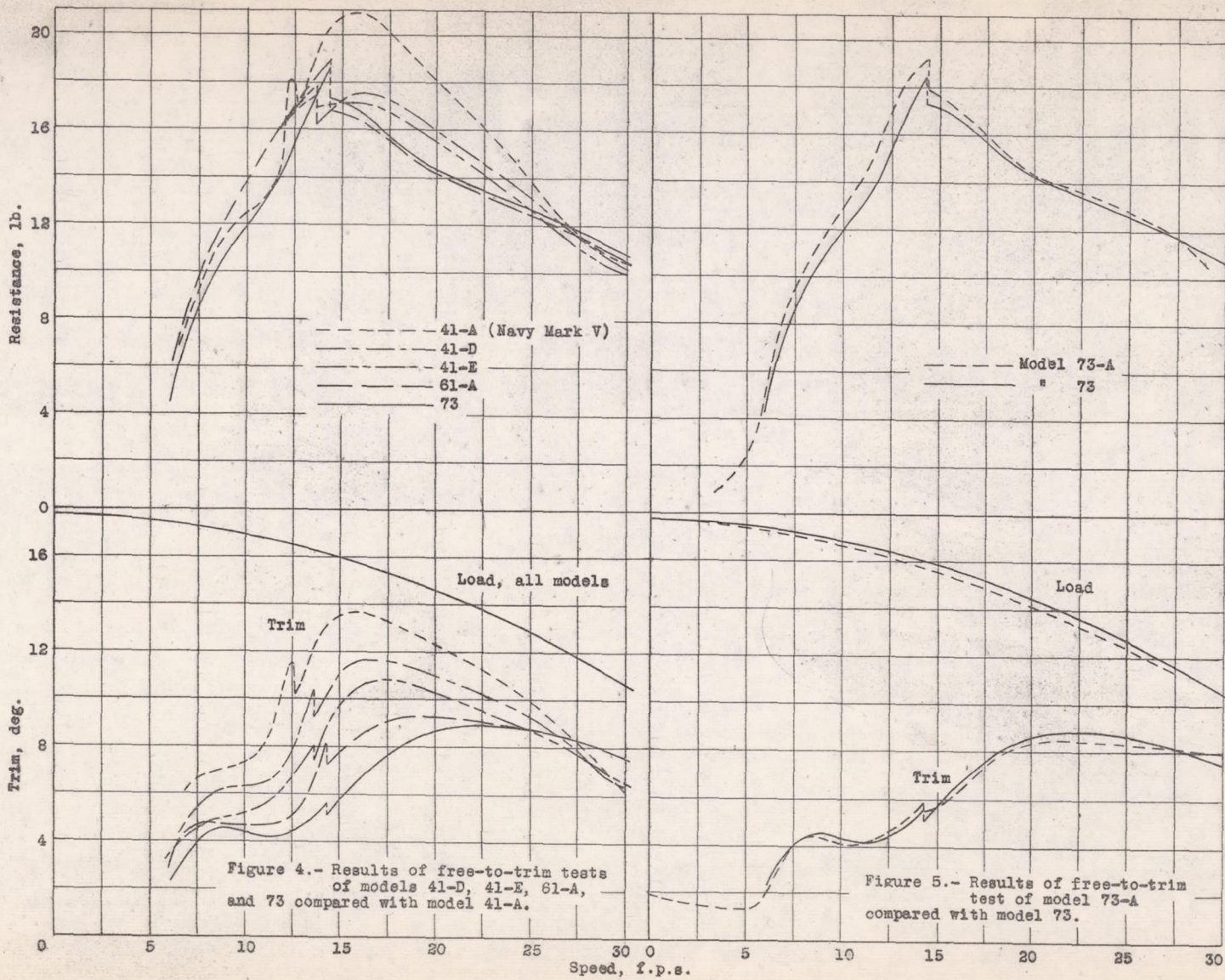
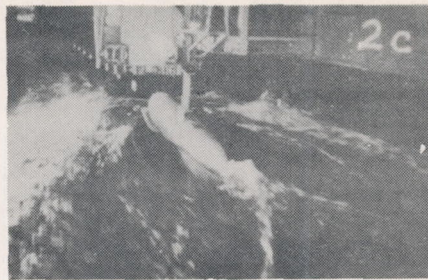
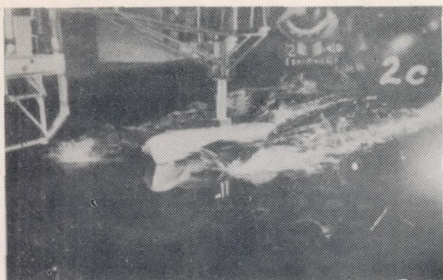
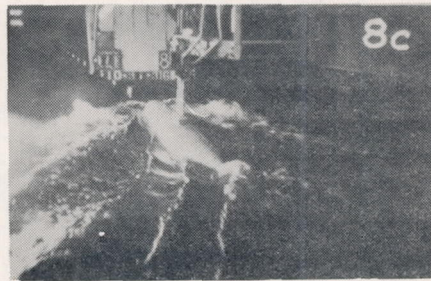
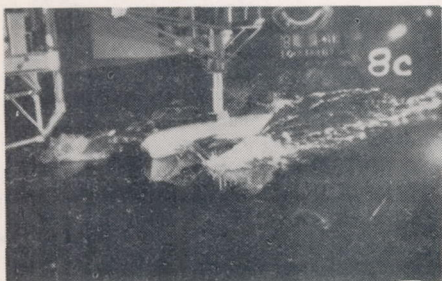

Figure 4.- Results of free-to-trim tests of models 41-D, 41-E, 61-A, and 73 compared with model 41-A.

Figure 5.- Results of free-to-trim test of model 73-A compared with model 73.



Model 41-D; $V=8.0$ f.p.s.; $\tau=5.8^\circ$



Model 41-E; $V=7.3$ f.p.s.; $\tau=4.4^\circ$

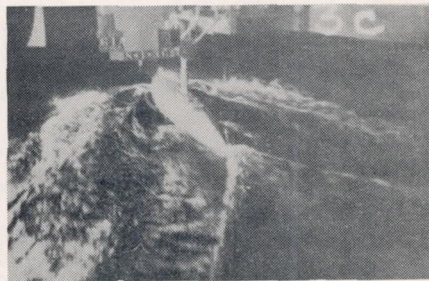
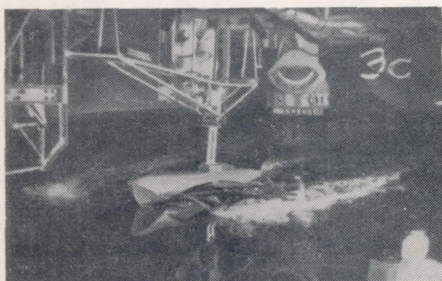

Model 61-A; $V=8.4$ f.p.s.; $\tau=4.9^\circ$

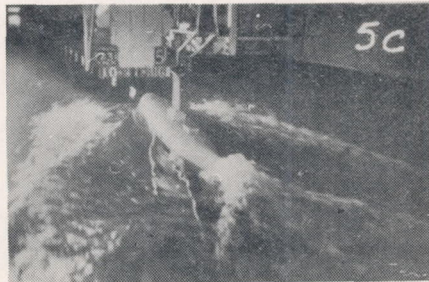
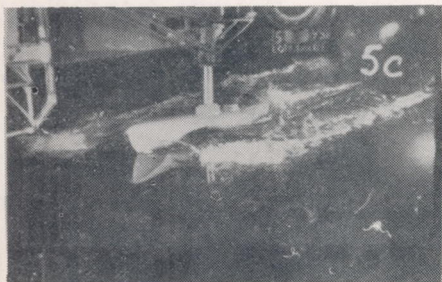

Model 73; $V=8.2$ f.p.s.; $\tau=4.5^\circ$

Figure 6.- Photographs of models free to trim at about 8 f.p.s.

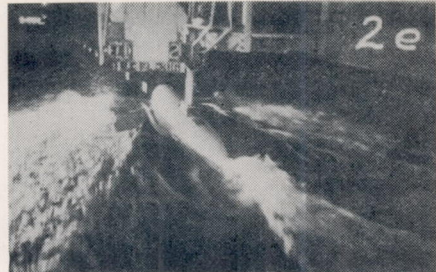
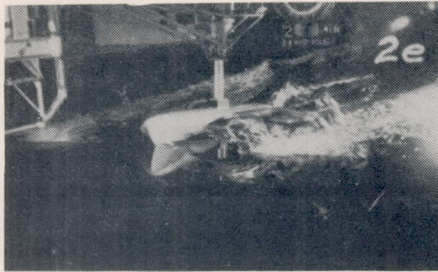

Model 41-D; $V=9.9$ f.p.s.; $\tau=6.3^\circ$

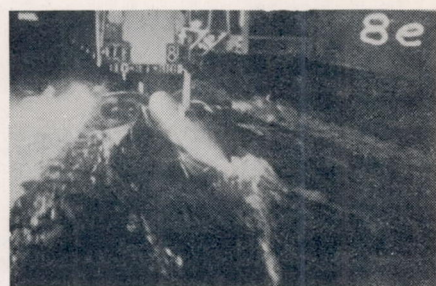
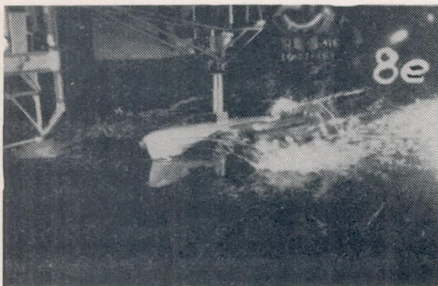

Model 41-E; $V=10.0$ f.p.s.; $\tau=5.2^\circ$

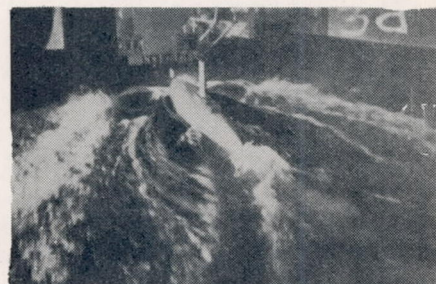
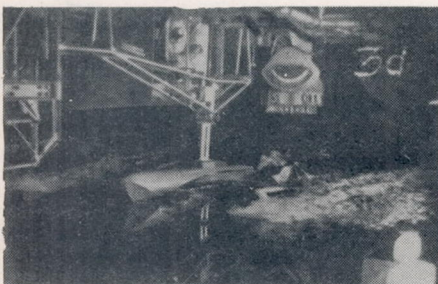

Model 61-A; $V=9.2$ f.p.s.; $\tau=4.7^\circ$

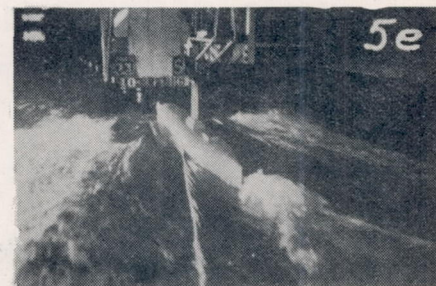
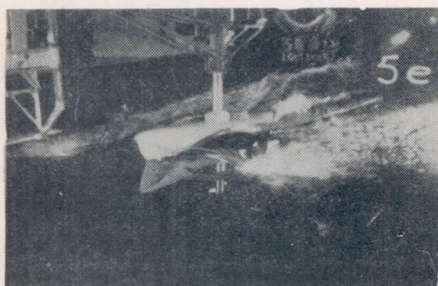

Model 73; $V=10.2$ f.p.s.; $\tau=4.4^\circ$

Figure 7.- Photographs of models free to trim at about 10 f.p.s.

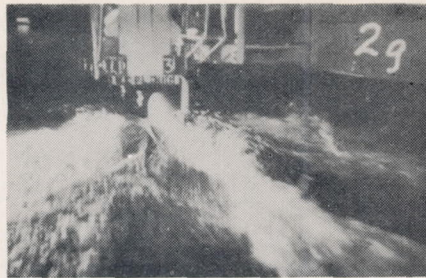
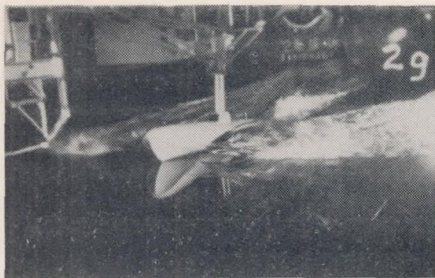

Model 41-D; $V=11.9$ f.p.s.; $\tau=7.1^\circ$

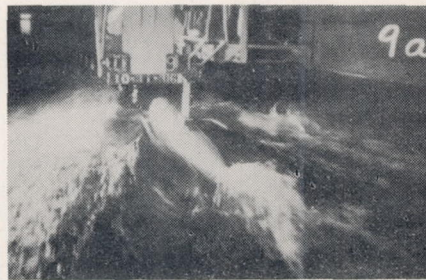
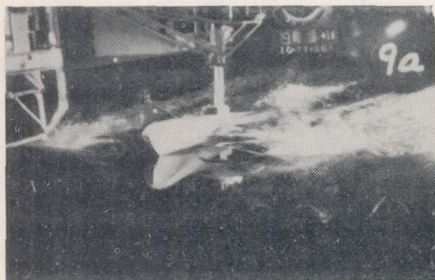

Model 41-E; $V=12.4$ f.p.s.; $\tau=6.7^\circ$

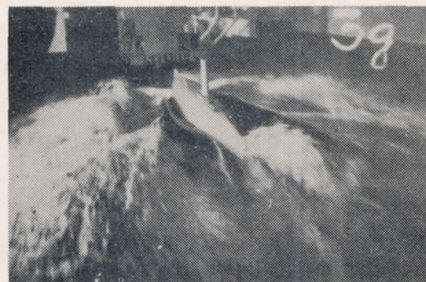
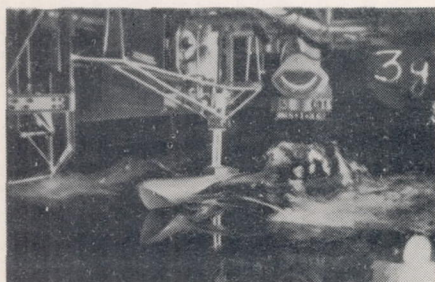

Model 61-A; $V=12.7$ f.p.s.; $\tau=5.3^\circ$

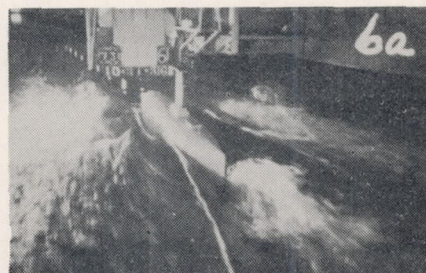
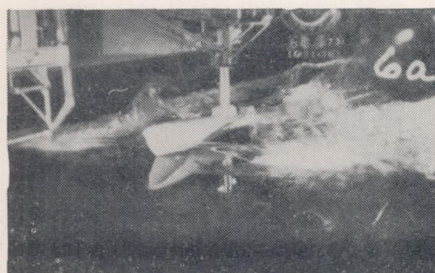

Model 73; $V=12.3$ f.p.s.; $\tau=4.4^\circ$

Figure 8.- Photographs of models free to trim at about 12 f.p.s.

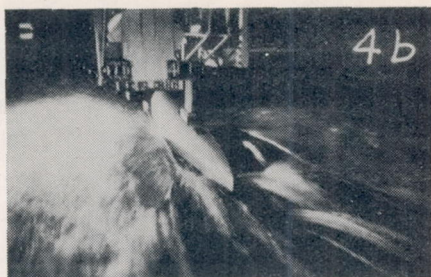
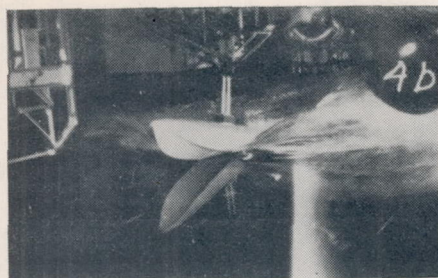

Model 41-D; $V=18.3$ f.p.s.; $\tau=11.5^\circ$

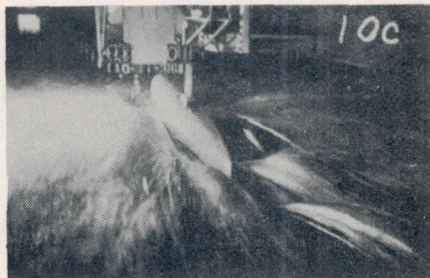
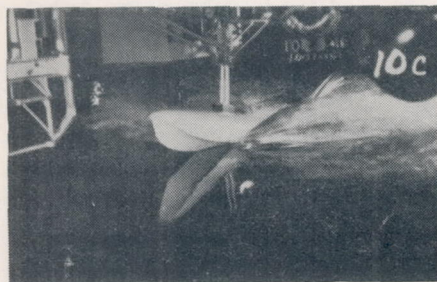

Model 41-E; $V=18.8$ f.p.s.; $\tau=10.6^\circ$

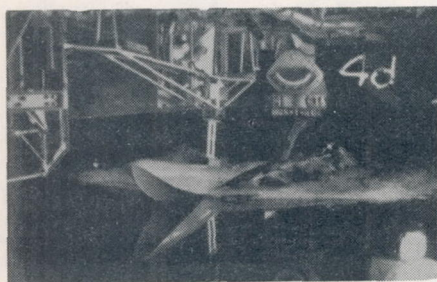

Model 61-A; $V=17.5$ f.p.s.; $\tau=9.1^\circ$

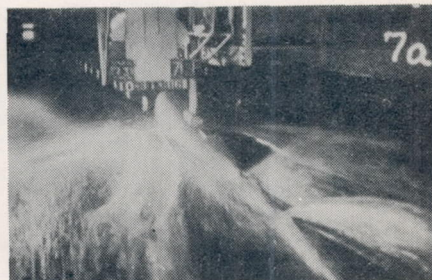
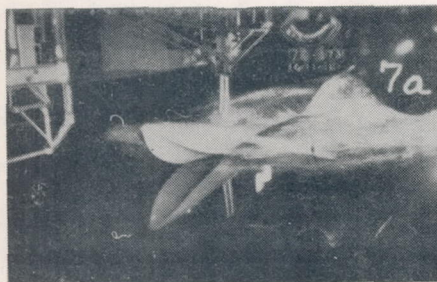

Model 73; $V=19.2$ f.p.s.; $\tau=8.4^\circ$

Figure 9.- Photographs of models free to trim at about 185f.p.s.

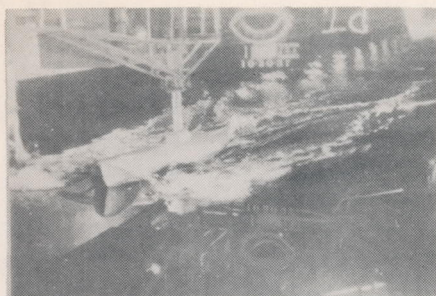

V=6.9 f.p.s.

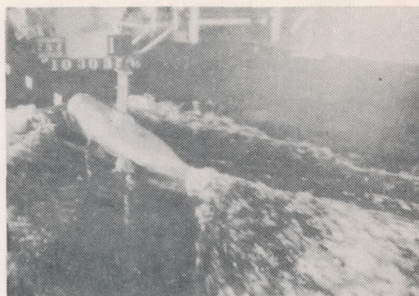

$\tau=3.2^\circ$

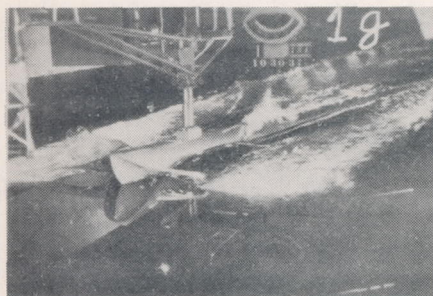

V=9.7 f.p.s.

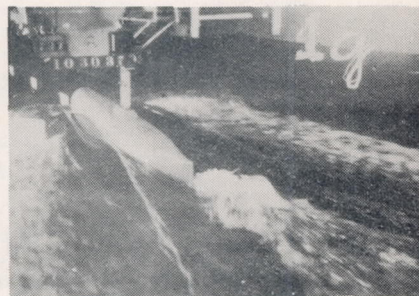

$\tau=4.2^\circ$

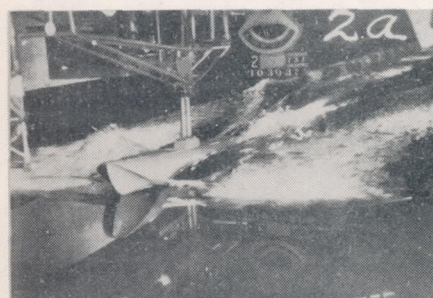

V=13.0 f.p.s.

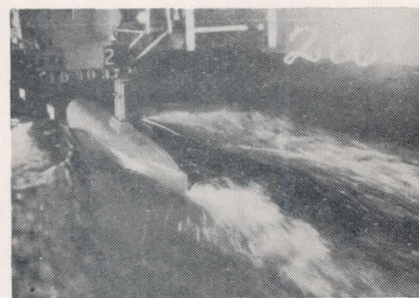

$\tau=4.9^\circ$

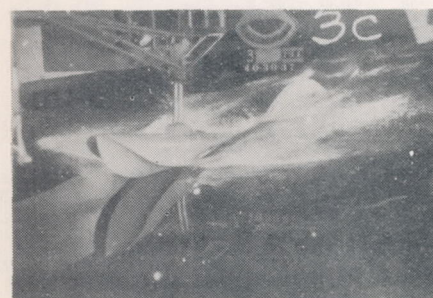

V=19.8 f.p.s.



$\tau=8.4^\circ$

Figure 10.- Photographs of model 73-A free to trim.

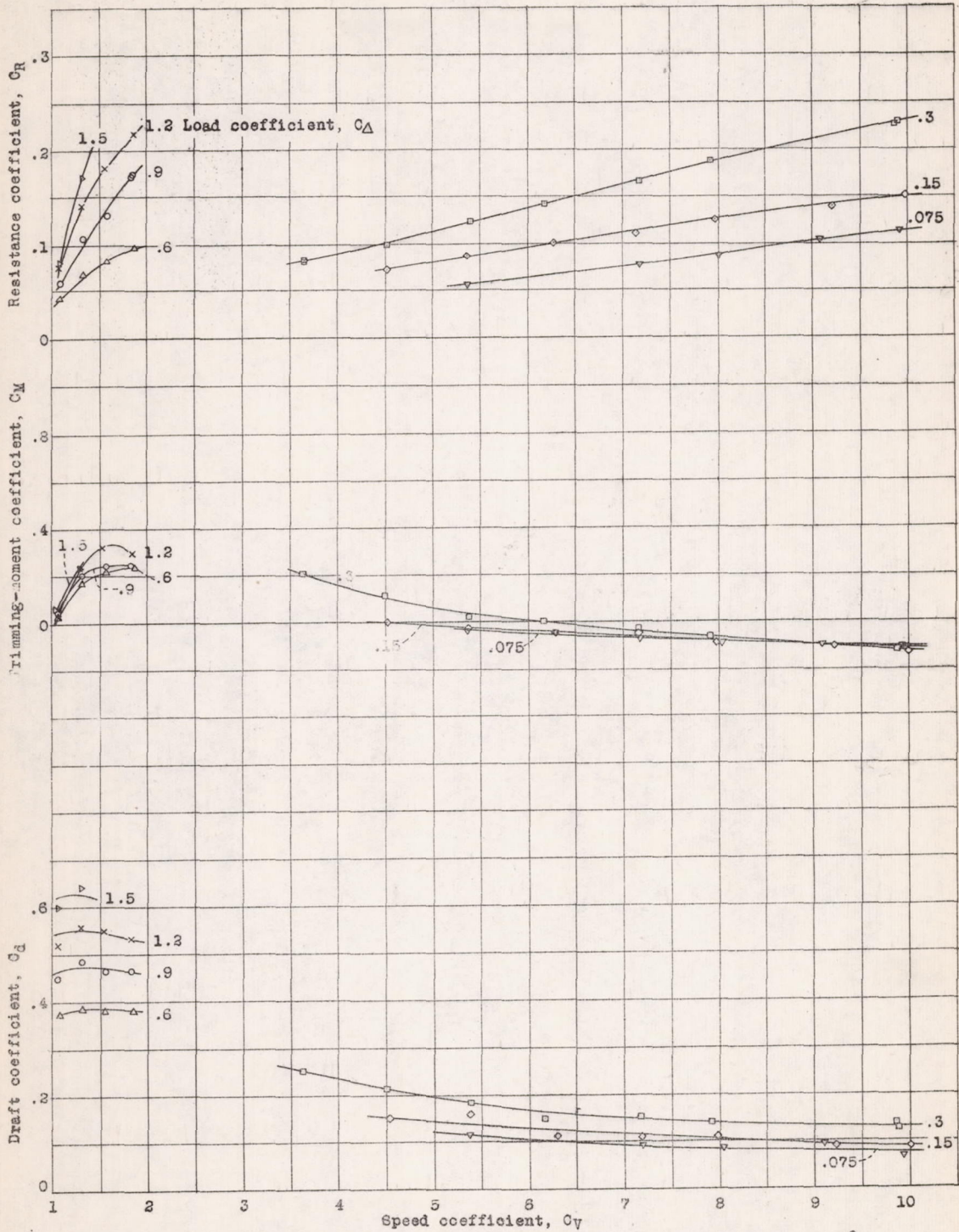

Figure 11.- Model 41-D. Resistance, trimming-moment, and draft coefficients. $\tau = 3^\circ$.

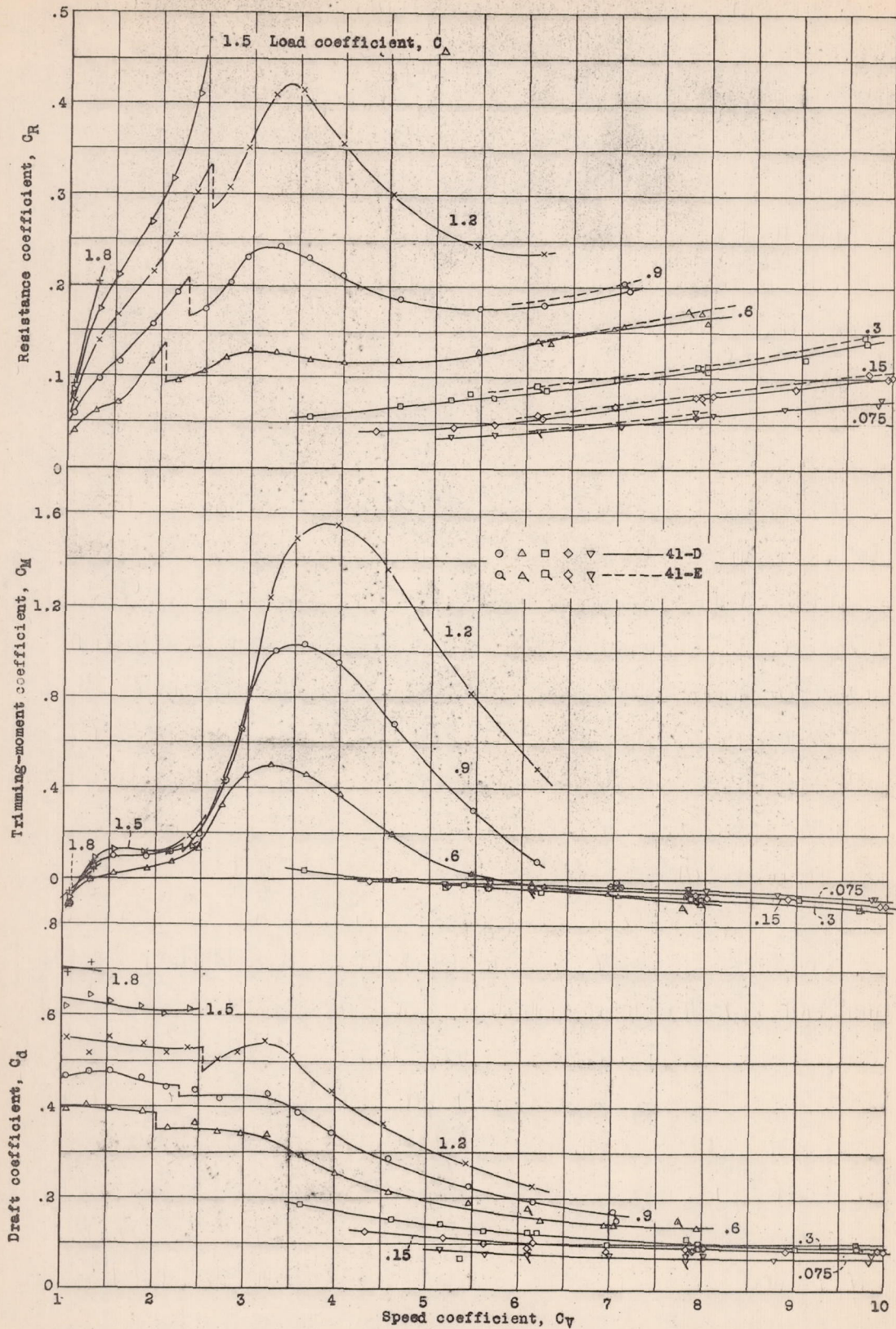

Figure 12.- Models 41-D and 41-E. Resistance, trimming-moment, and draft coefficients. $\tau = 5^\circ$.

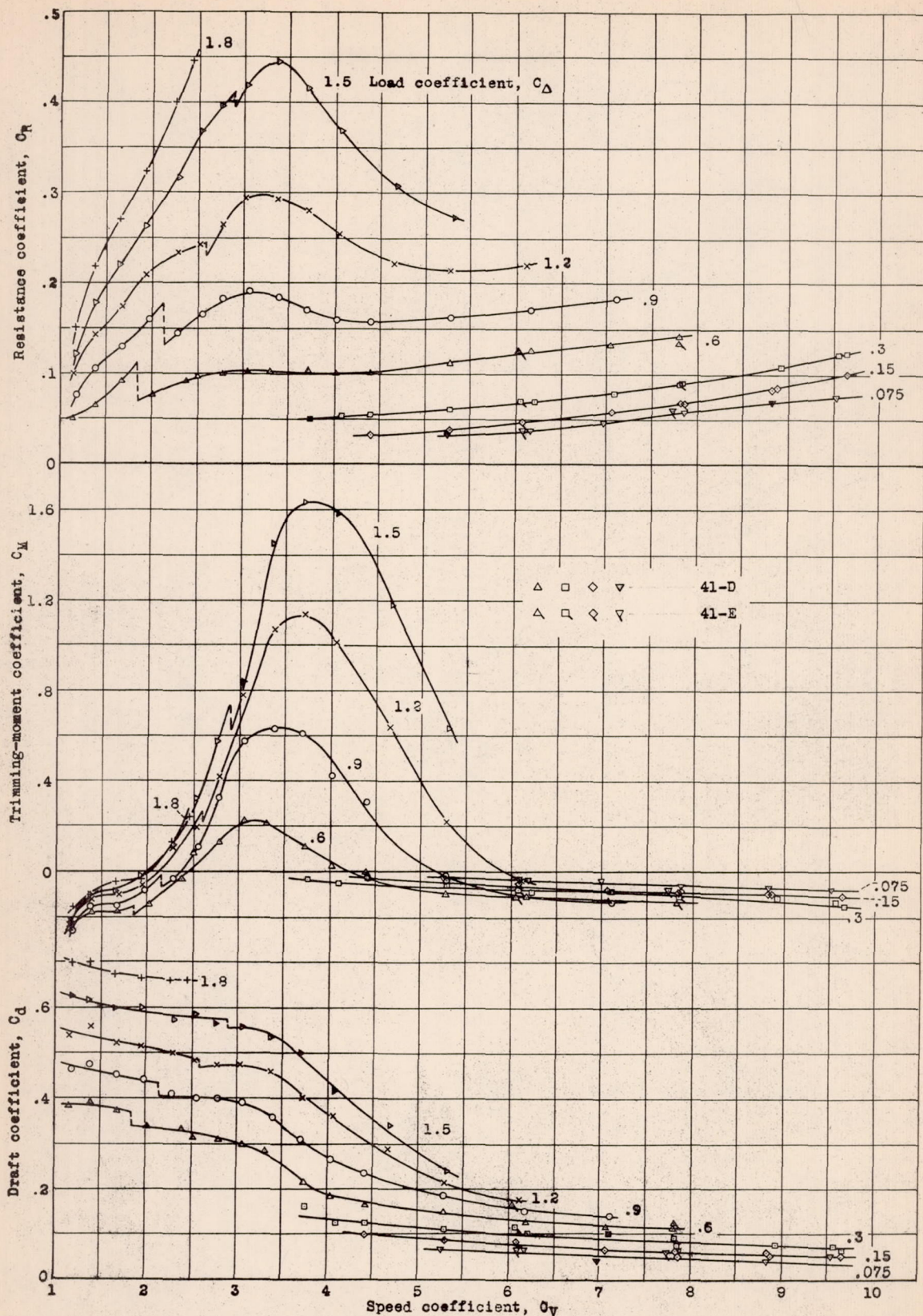

Figure 13.- Models 41-D and 41-E. Resistance, trimming-moment, and draft coefficients. $\tau = 7^\circ$.

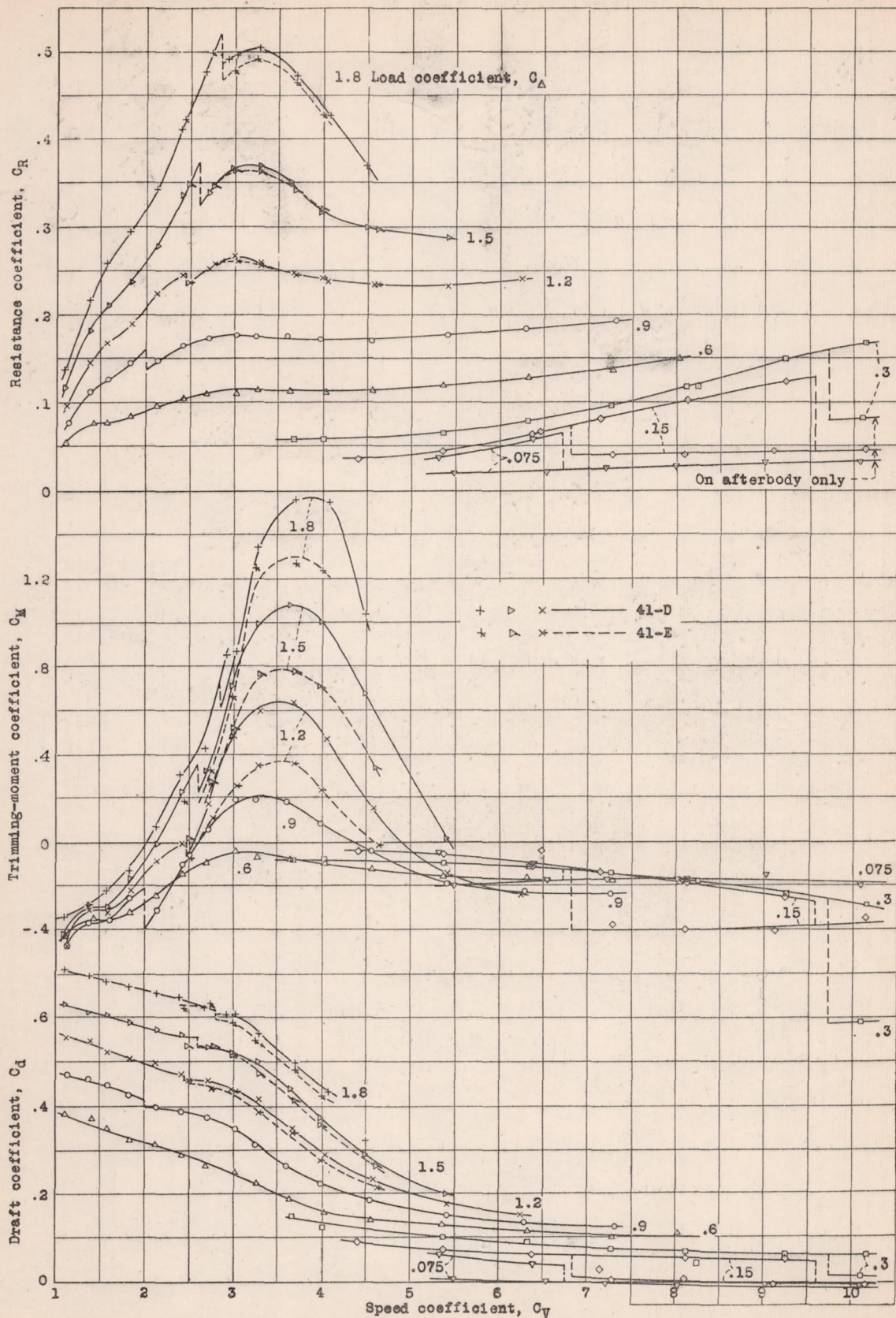

Figure 14.- Models 41-D and 41-E. Resistance, trimming-moment, and draft coefficients. $\tau = 9^\circ$.

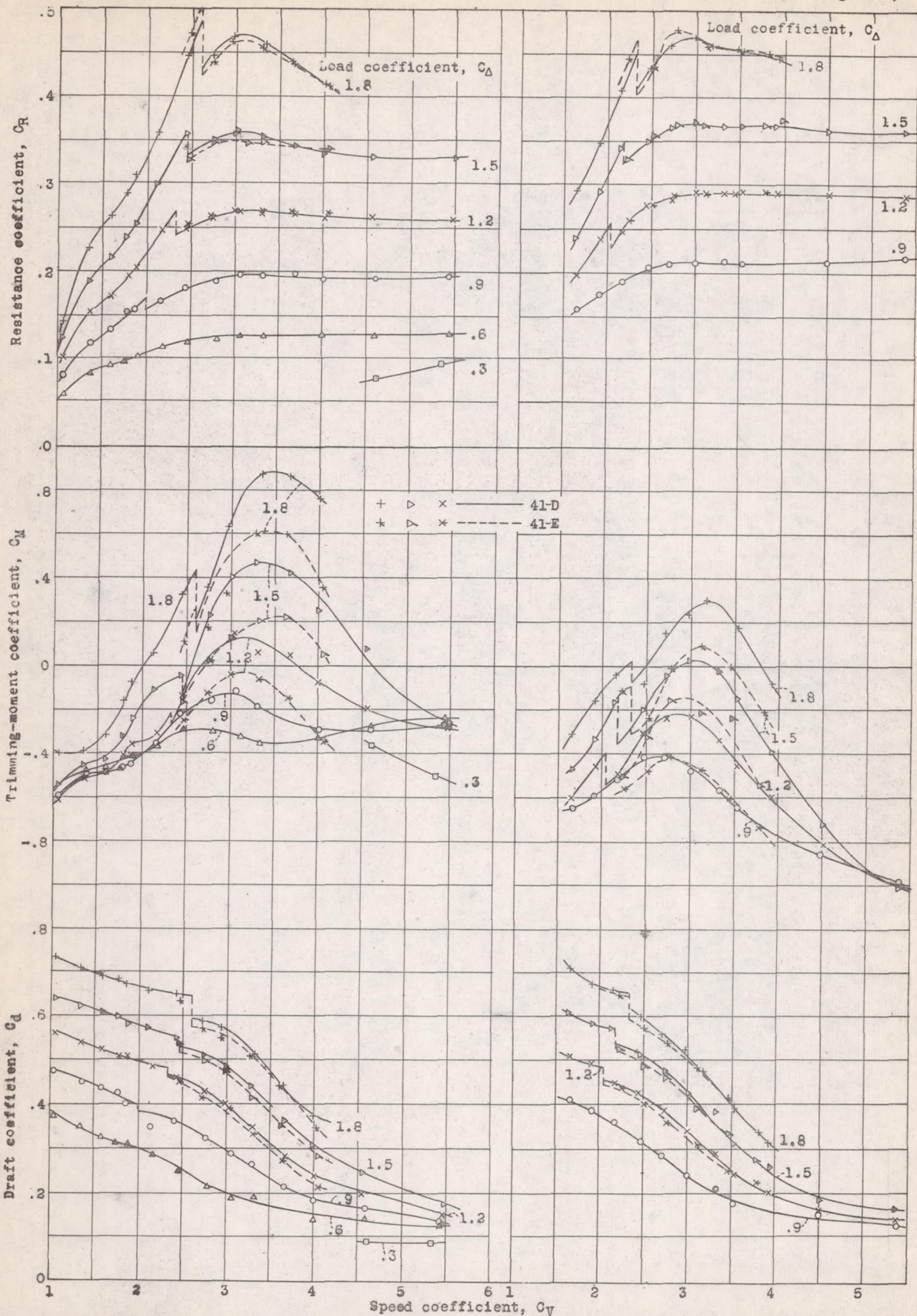

Figure 15.- Models 41-D and 41-E. Resistance, trimming-moment, and draft coefficients. $\tau = 11^\circ$. Figure 16.- Models 41-D & 41-E. Resistance, trimming-moment, and draft coefficients. $\tau = 13^\circ$.

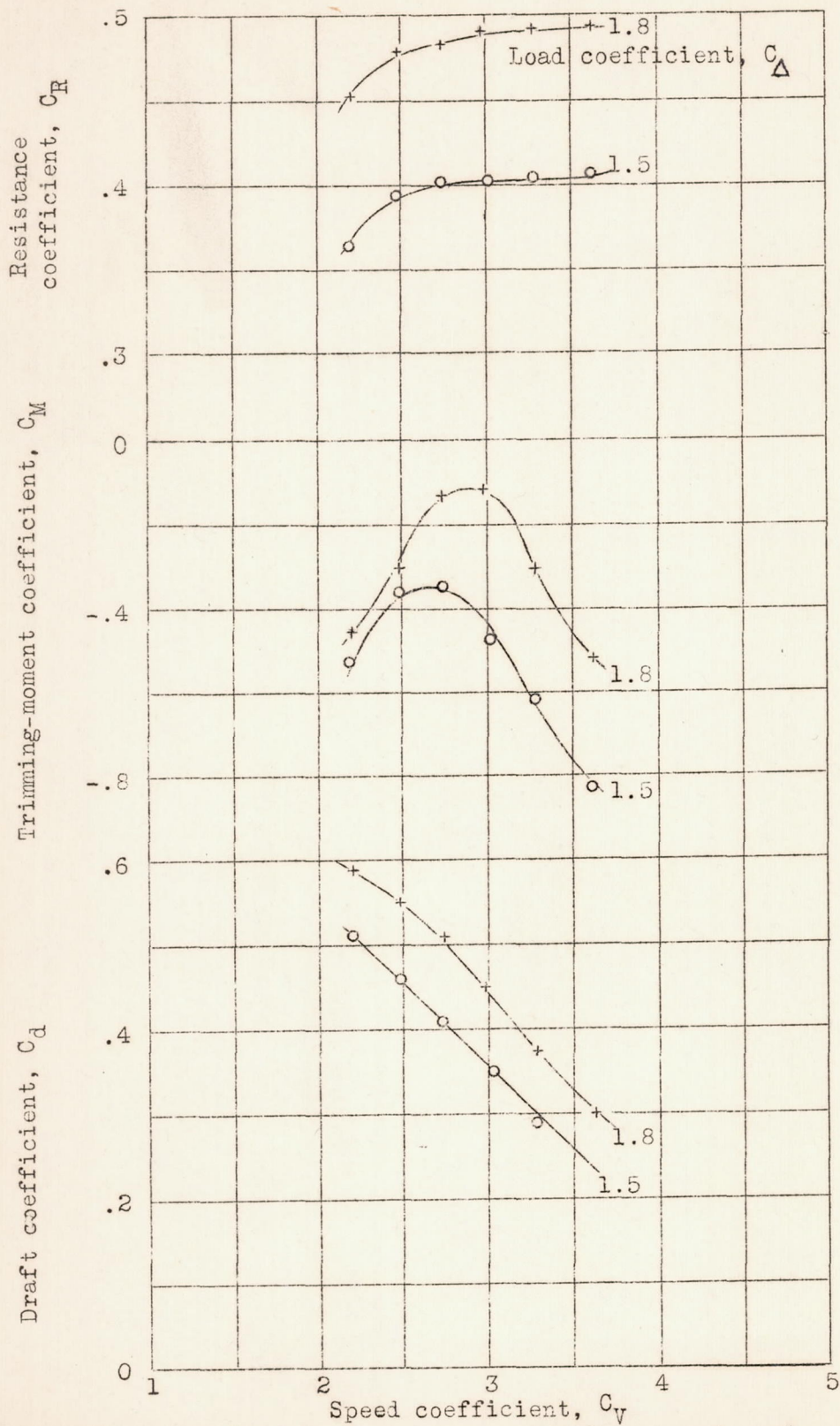

Figure 17.- Model 41-D. Resistance, trimming-moment, and draft coefficients. $\tau = 15^\circ$.

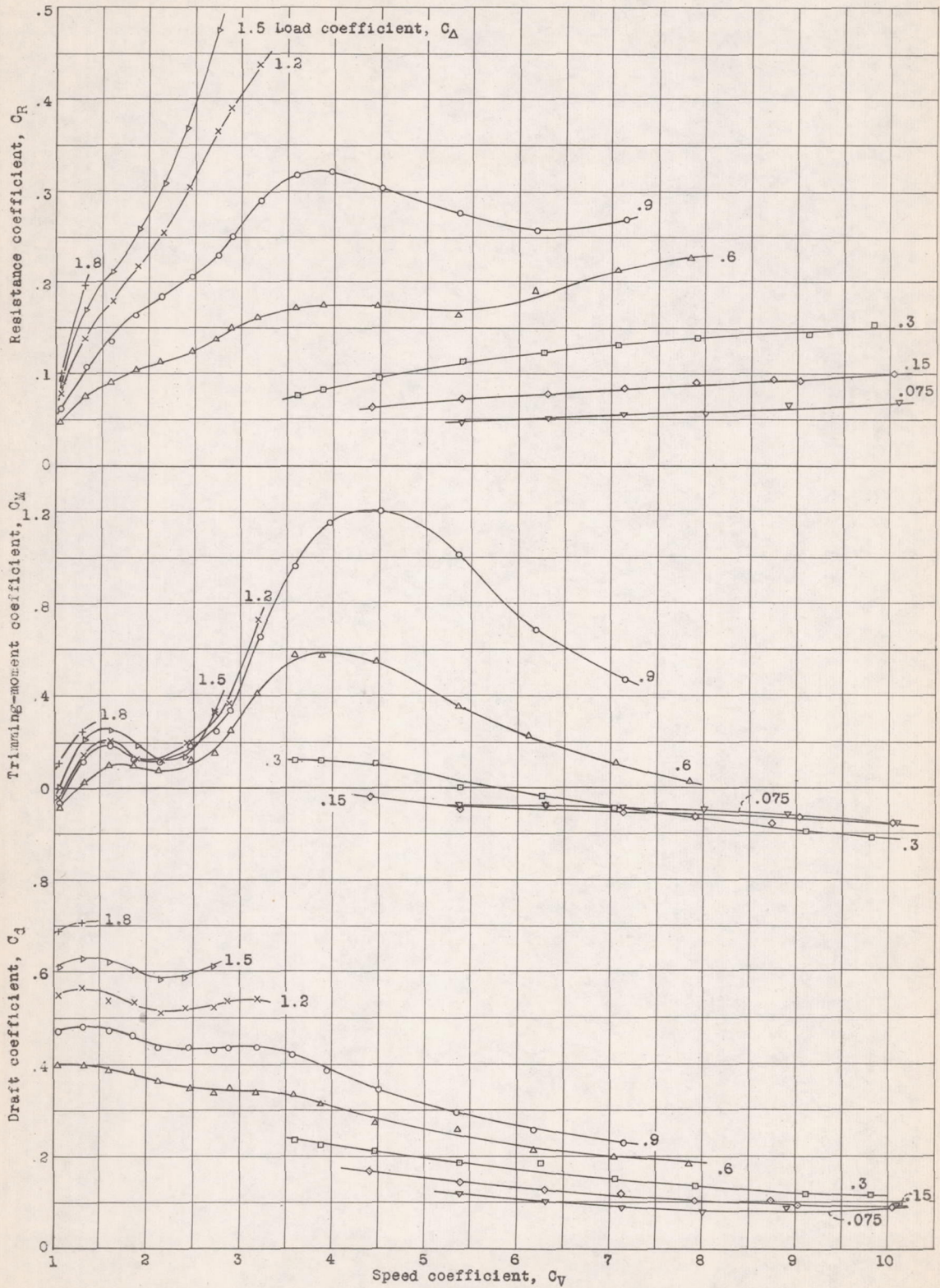

Figure 18.- Model 61-A. Resistance, trimming-moment, and draft coefficients. $\tau = 3^\circ$.

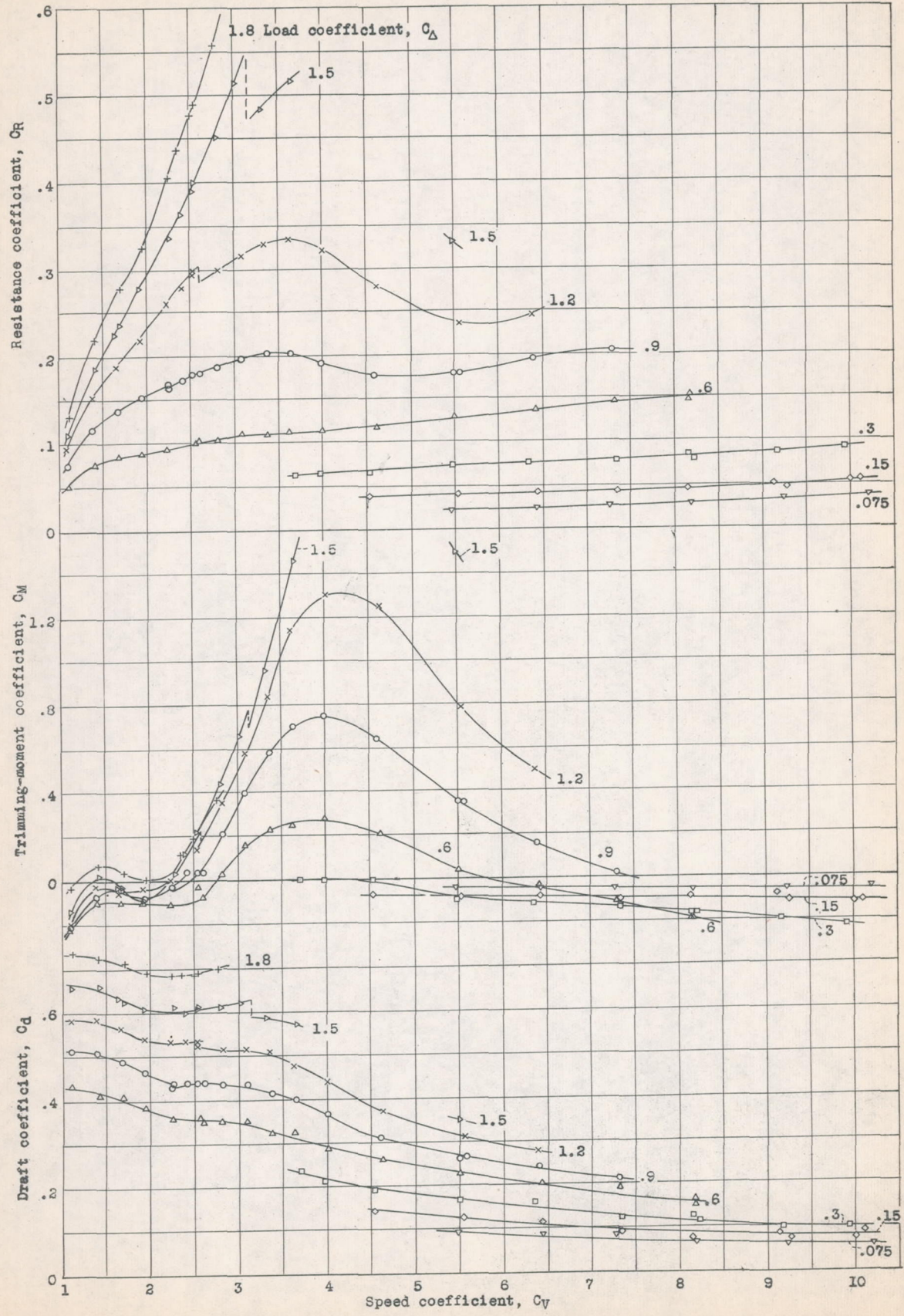

Figure 19.- Model 61-A. Resistance, trimming-moment, and draft coefficients. $\tau = 5^\circ$.

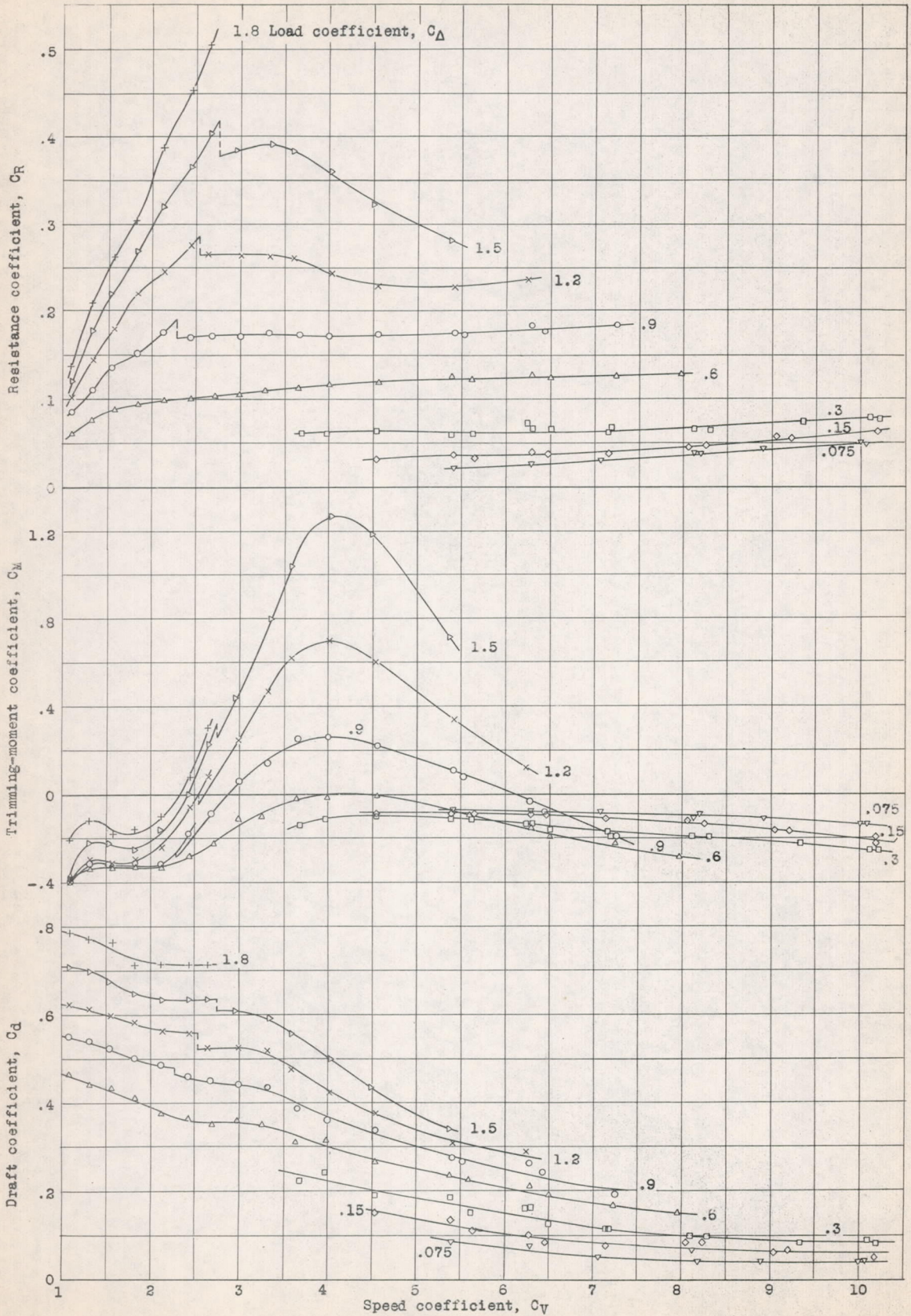

Figure 20.- Model 61-A. Resistance, trimming-moment, and draft coefficients. $\tau = 7^\circ$.

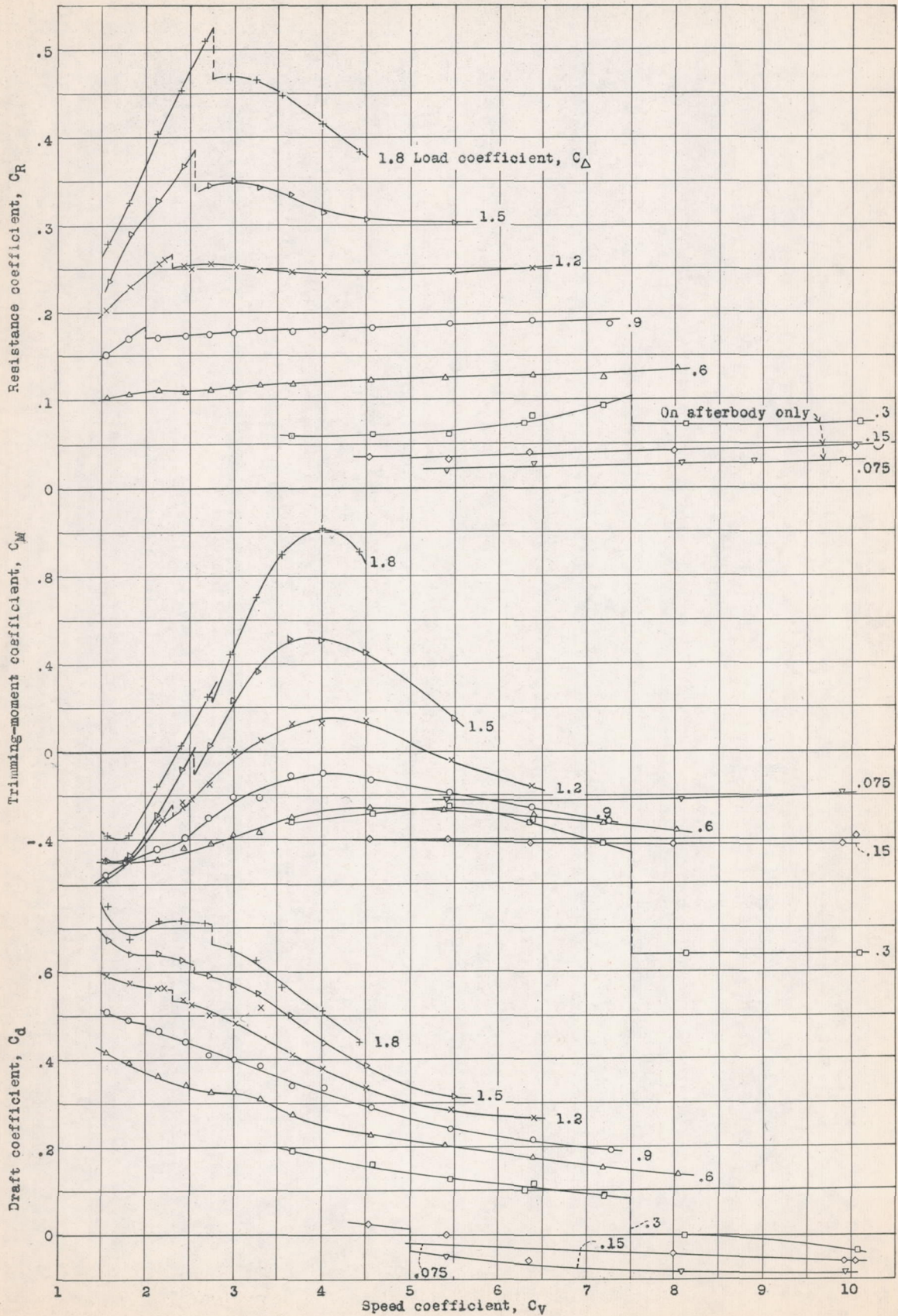

Figure 21.- Model 61-A. Resistance, trimming-moment, and draft coefficients. $\tau = 9^\circ$.

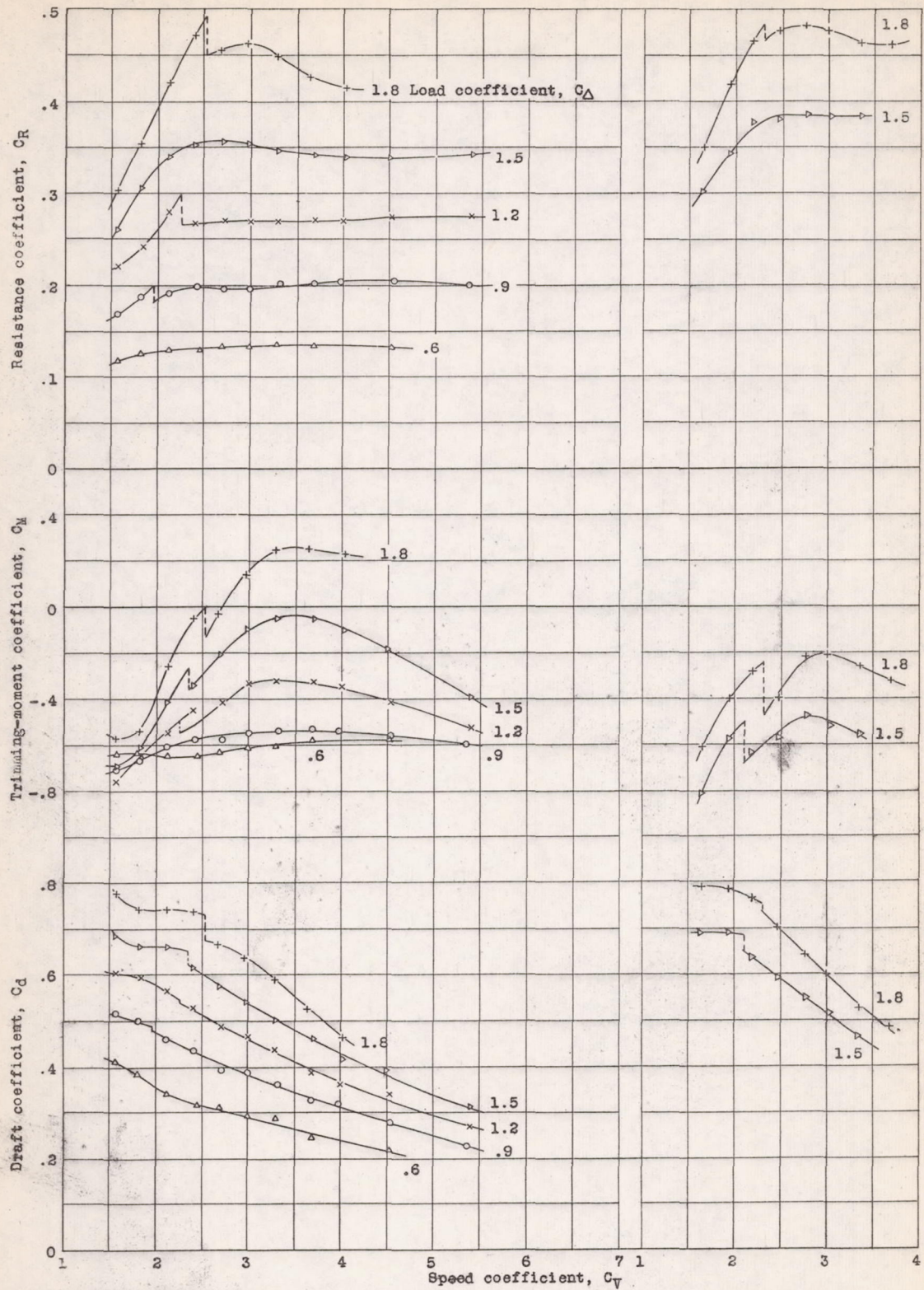

Figure 22.- Model 61-A. Resistance, trimming-moment, and draft coefficients. $\tau = 11^\circ$.

Figure 23.- Model 61-A. Resistance, trimming-moment, and draft coefficients. $\tau = 13^\circ$.

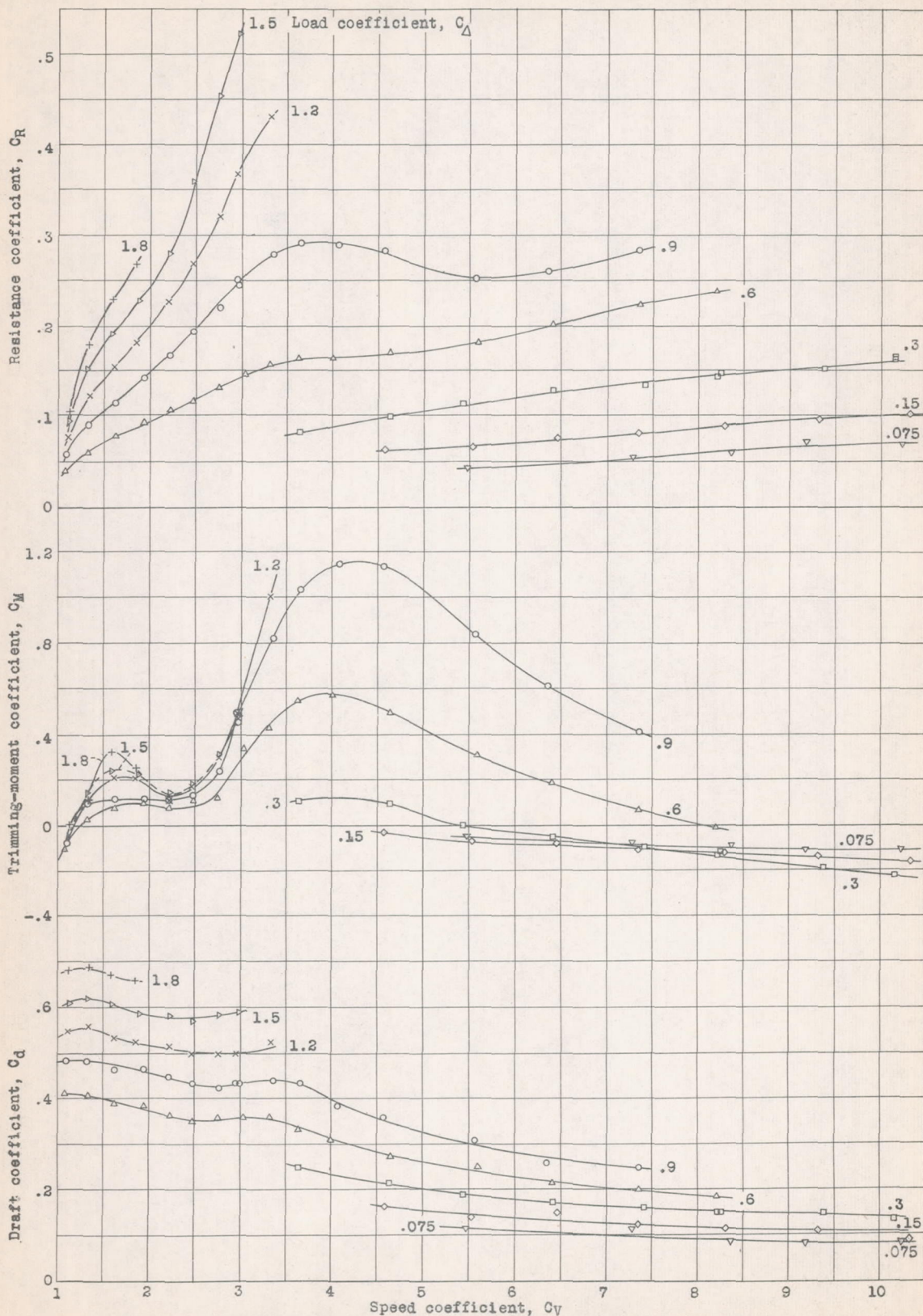

Figure 24.- Model 73. Resistance, trimming-moment, and draft coefficients. $\tau = 3^\circ$.

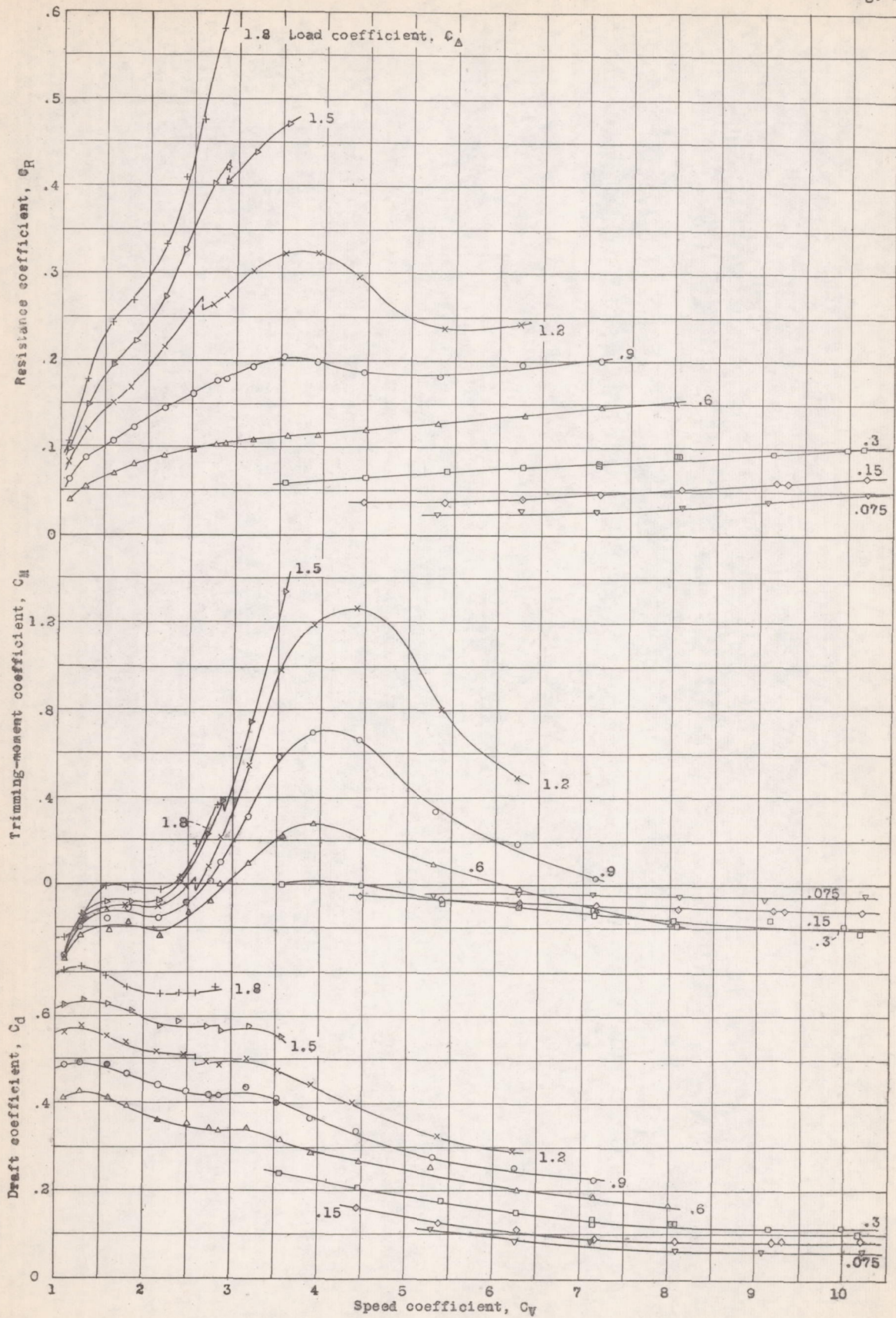

Figure 25.- Model 73. Resistance, trimming-moment, and draft coefficients. $\tau = 5^\circ$.

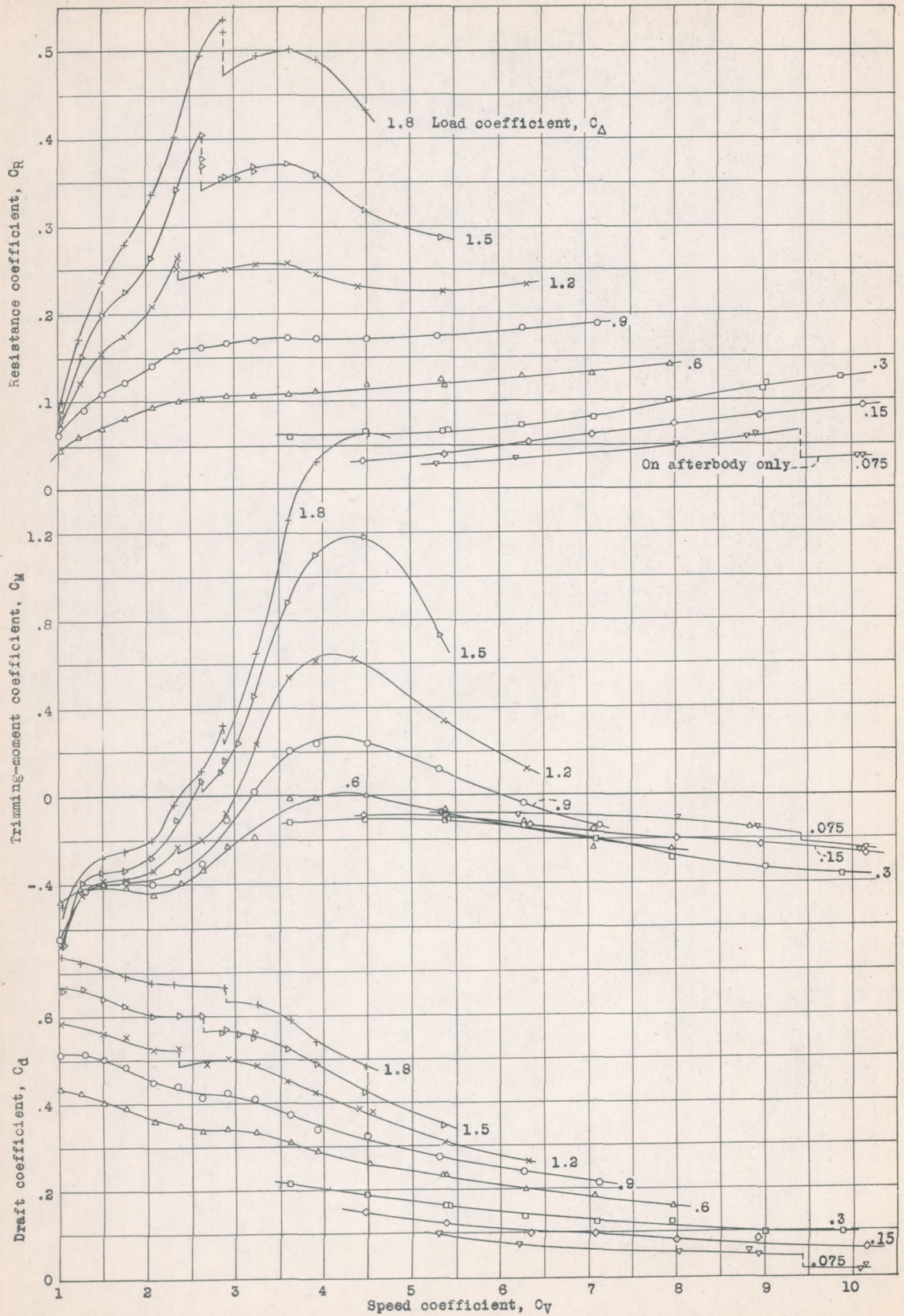

Figure 26.- Model 73. Resistance, trimming-moment, and draft coefficients. $\tau = 7^\circ$.

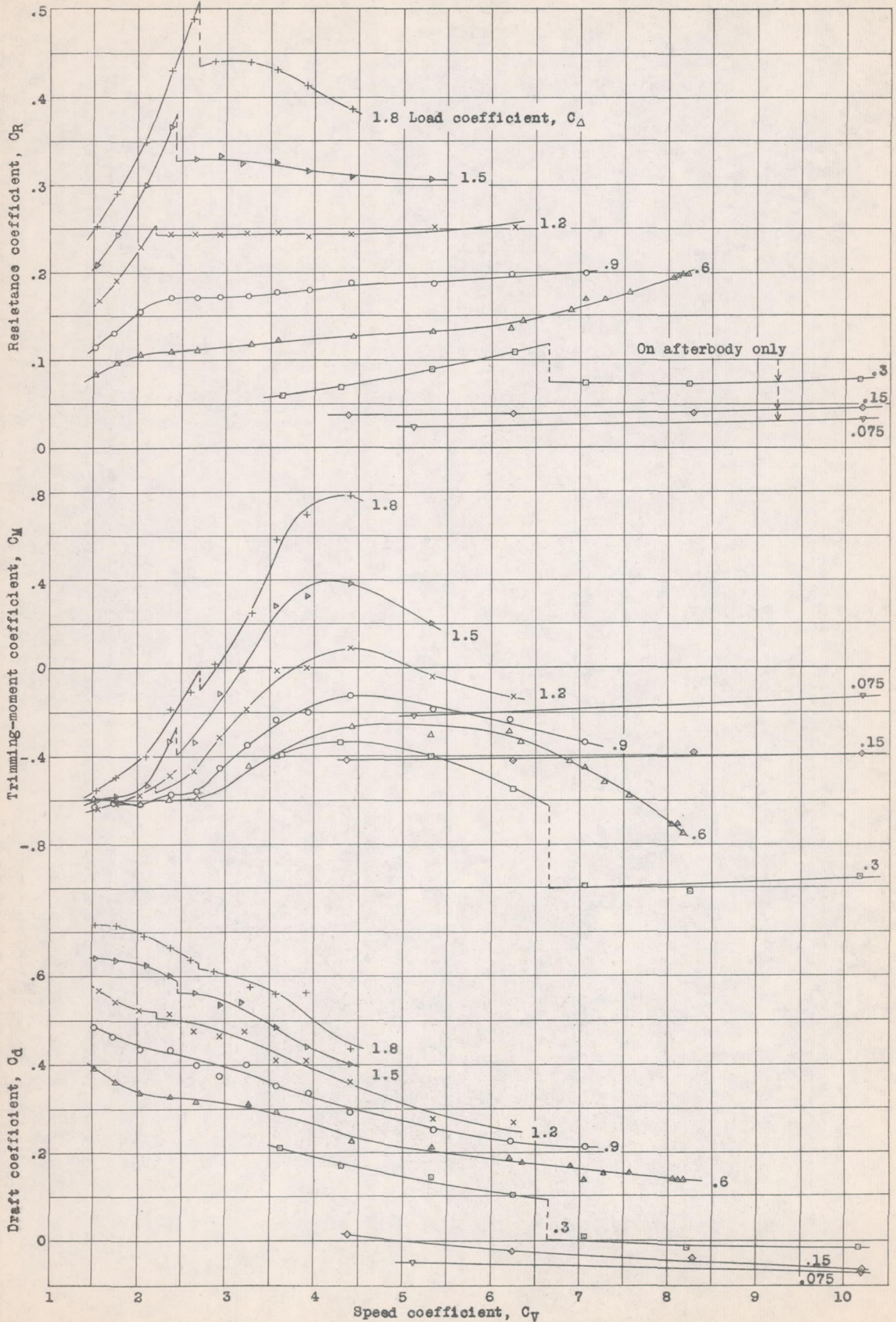

Figure 27.- Model 73. Resistance, trimming-moment, and draft coefficients. $\tau = 9^\circ$.

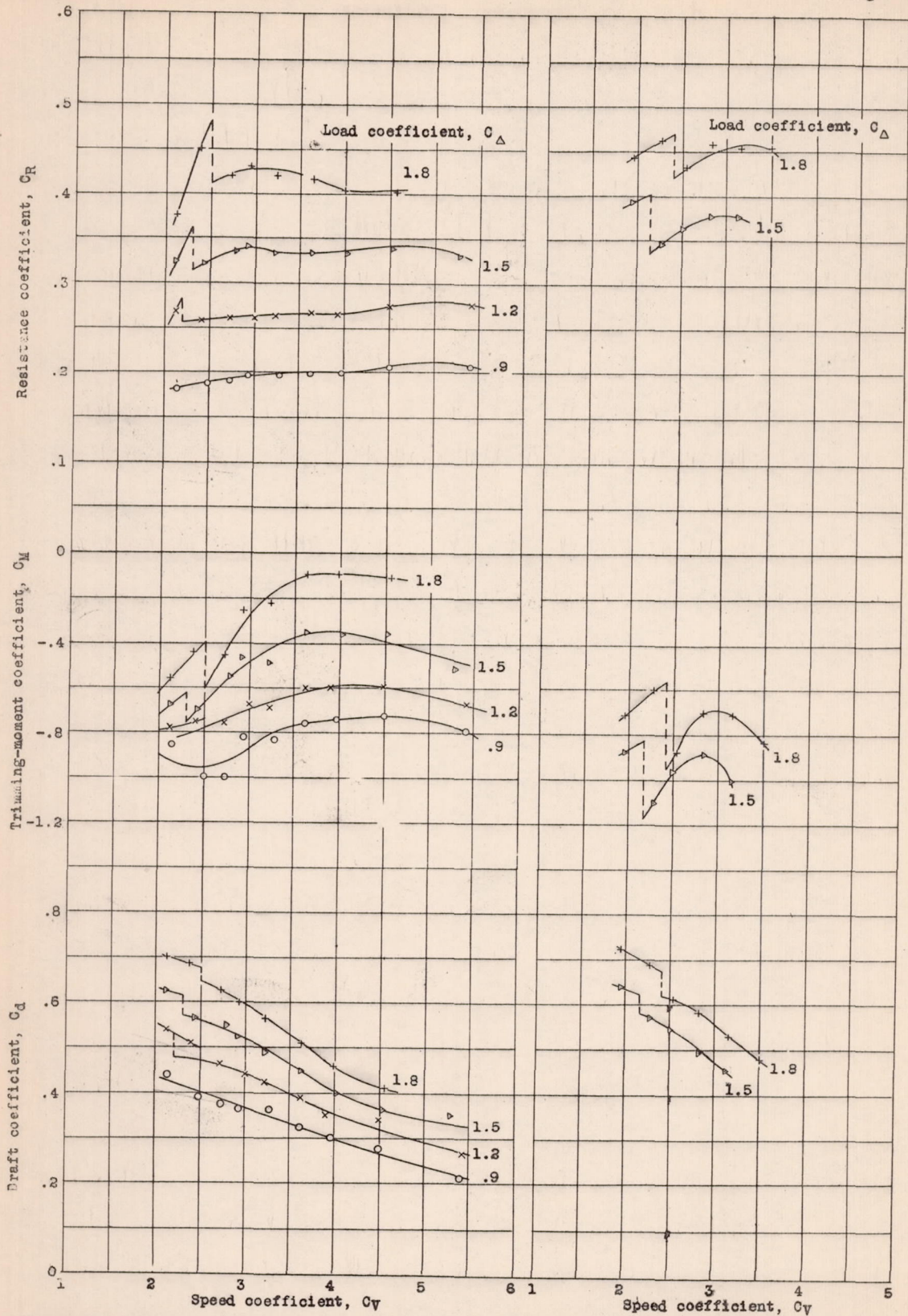

Figure 28.- Model 73. Resistance, trimming-moment, and draft coefficients. $\tau = 11^\circ$.

Figure 29.- Model 73. Resistance, trimming-moment, and draft coefficients. $\tau = 13^\circ$.

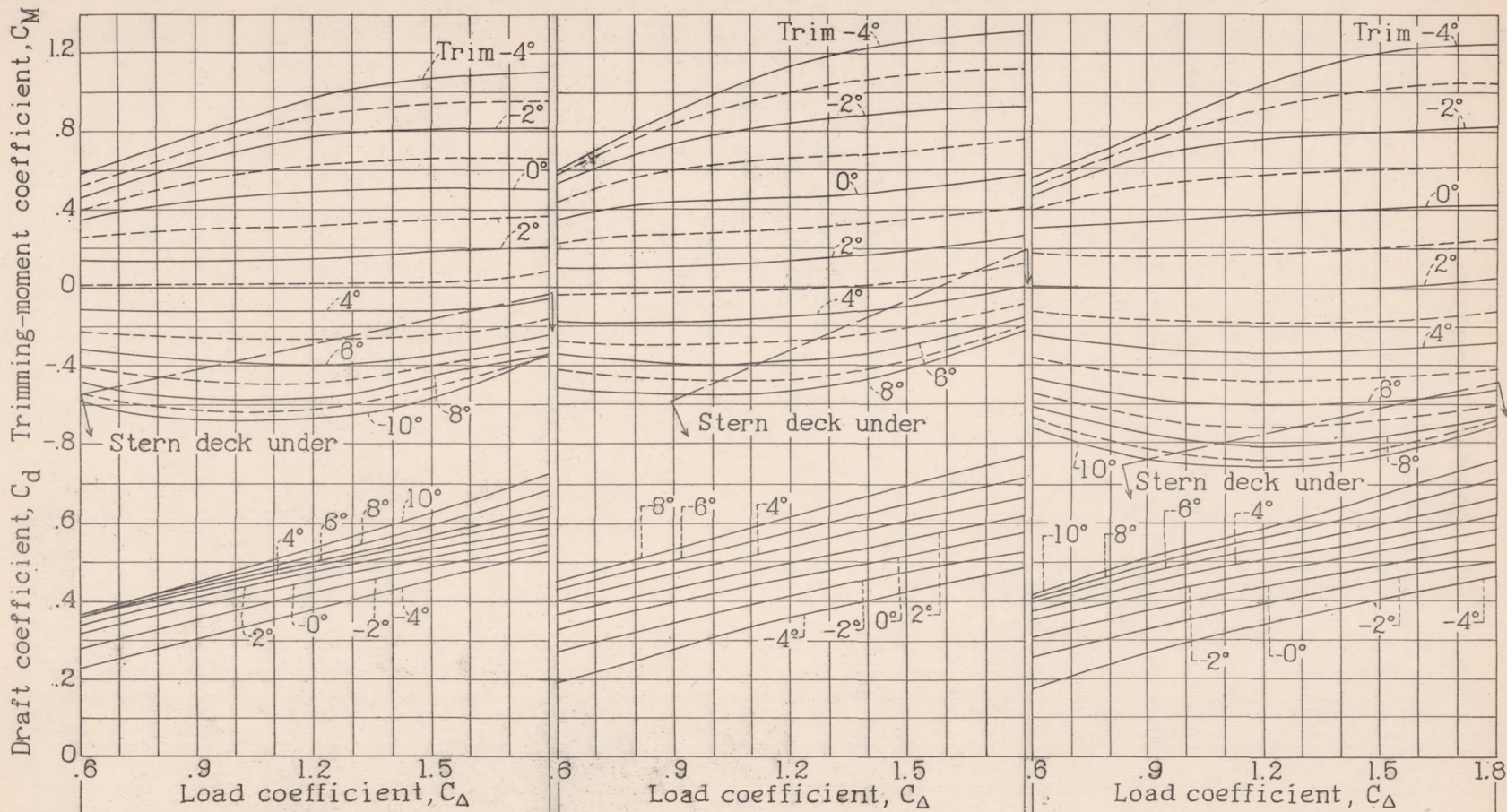

Figure 30.- Model 41-D. Static properties.

Figure 31.- Model 61-A. Static properties.

Figure 32.- Model 73. Static properties.

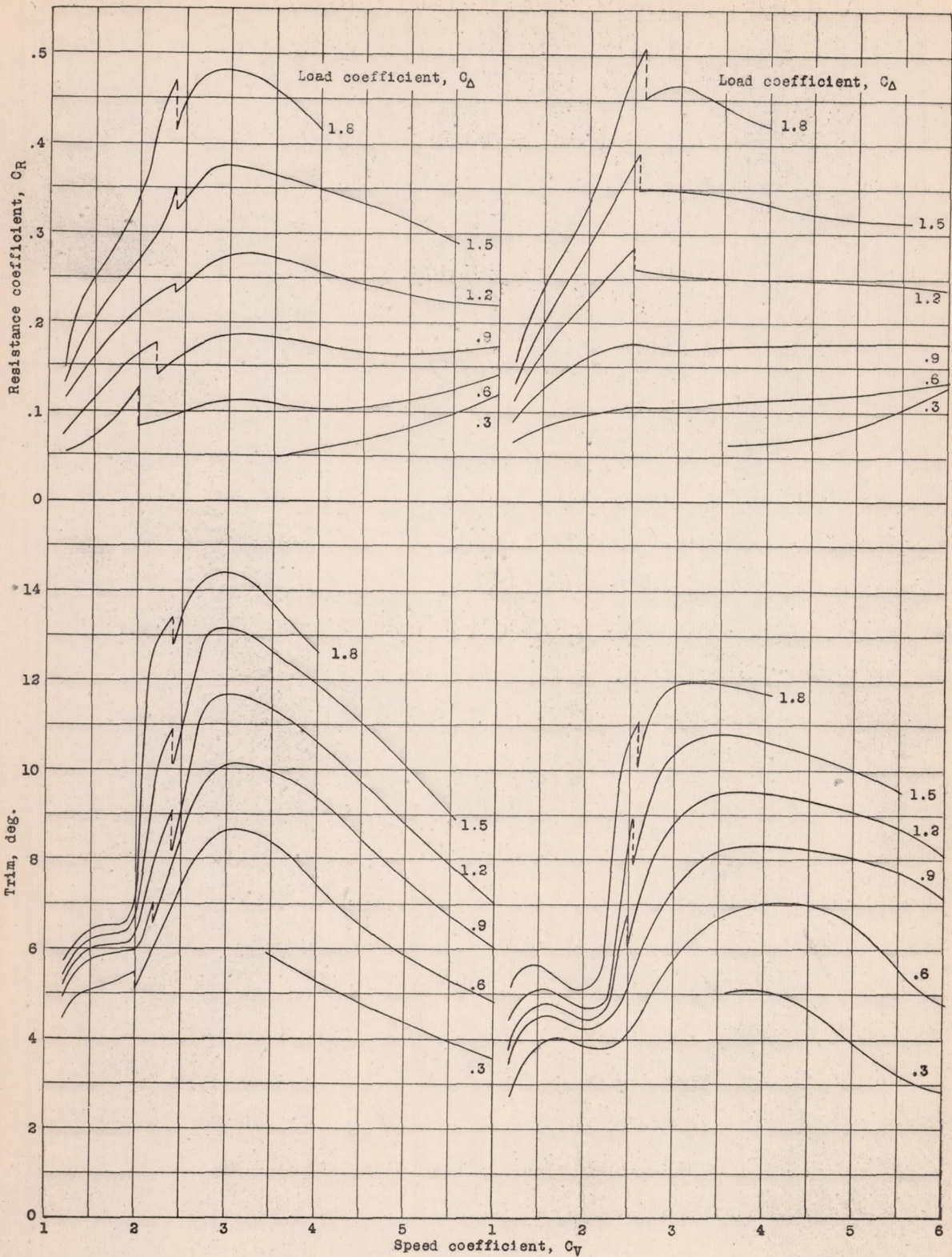

Figure 33.- Model 41-D. Resistance coefficient and trim for zero trimming moment.

Figure 34.- Model 61-A. Resistance coefficient and trim for zero trimming moment.

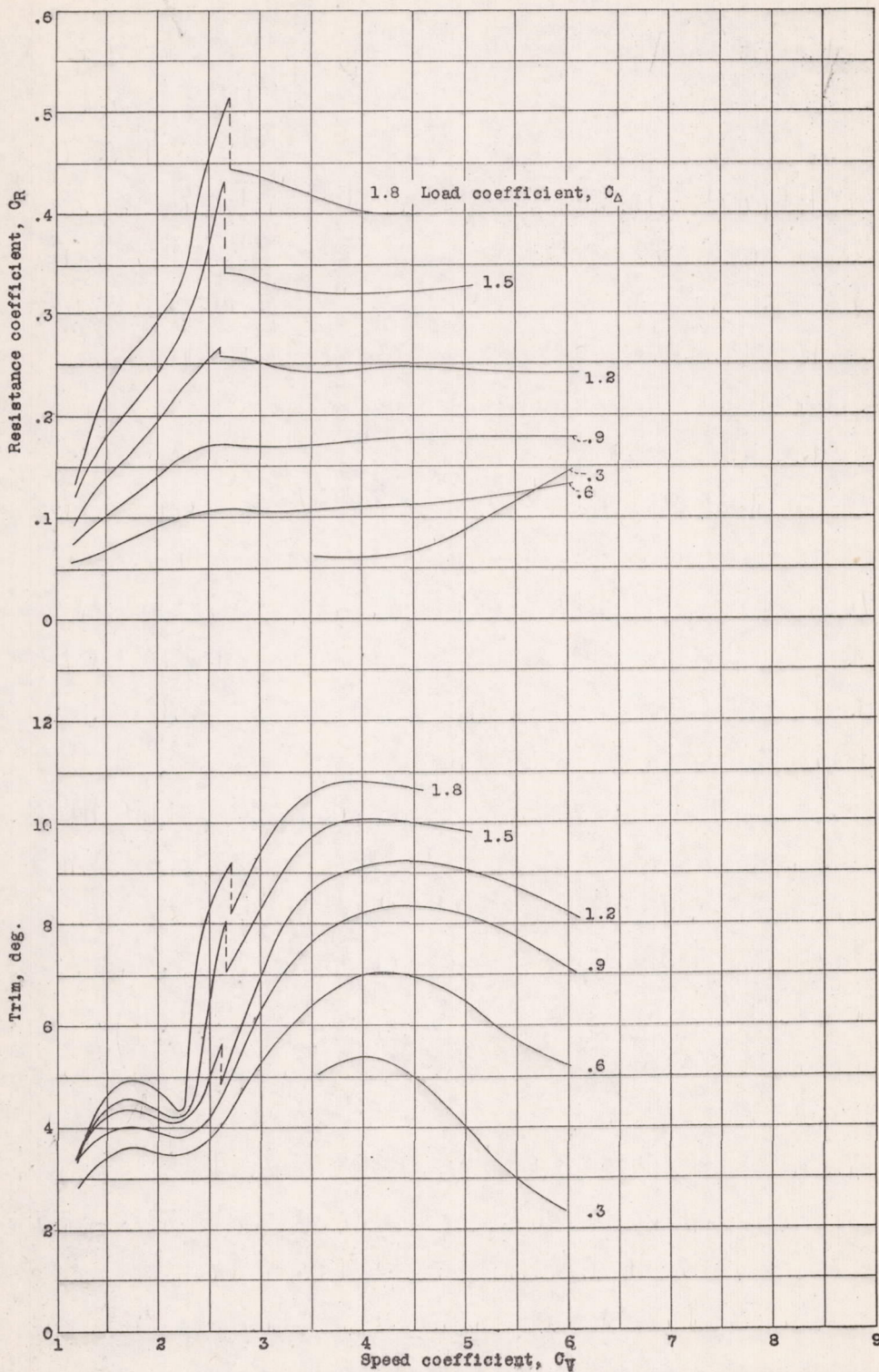

Figure 35.- Model 73. Resistance coefficient and trim for zero trimming moment.

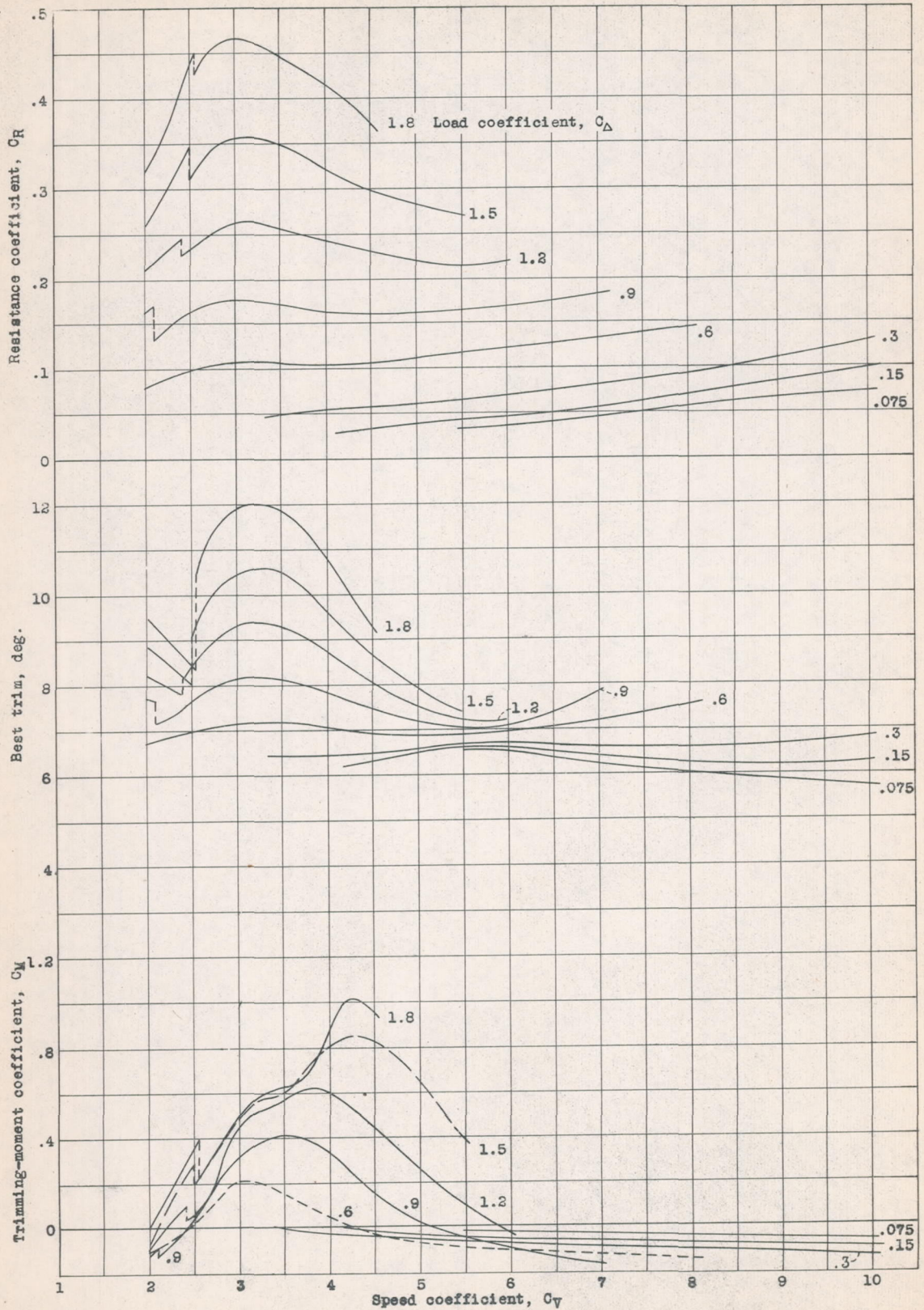

Figure 36.- Model 41-D. Characteristics at best trim with forebody in the water.

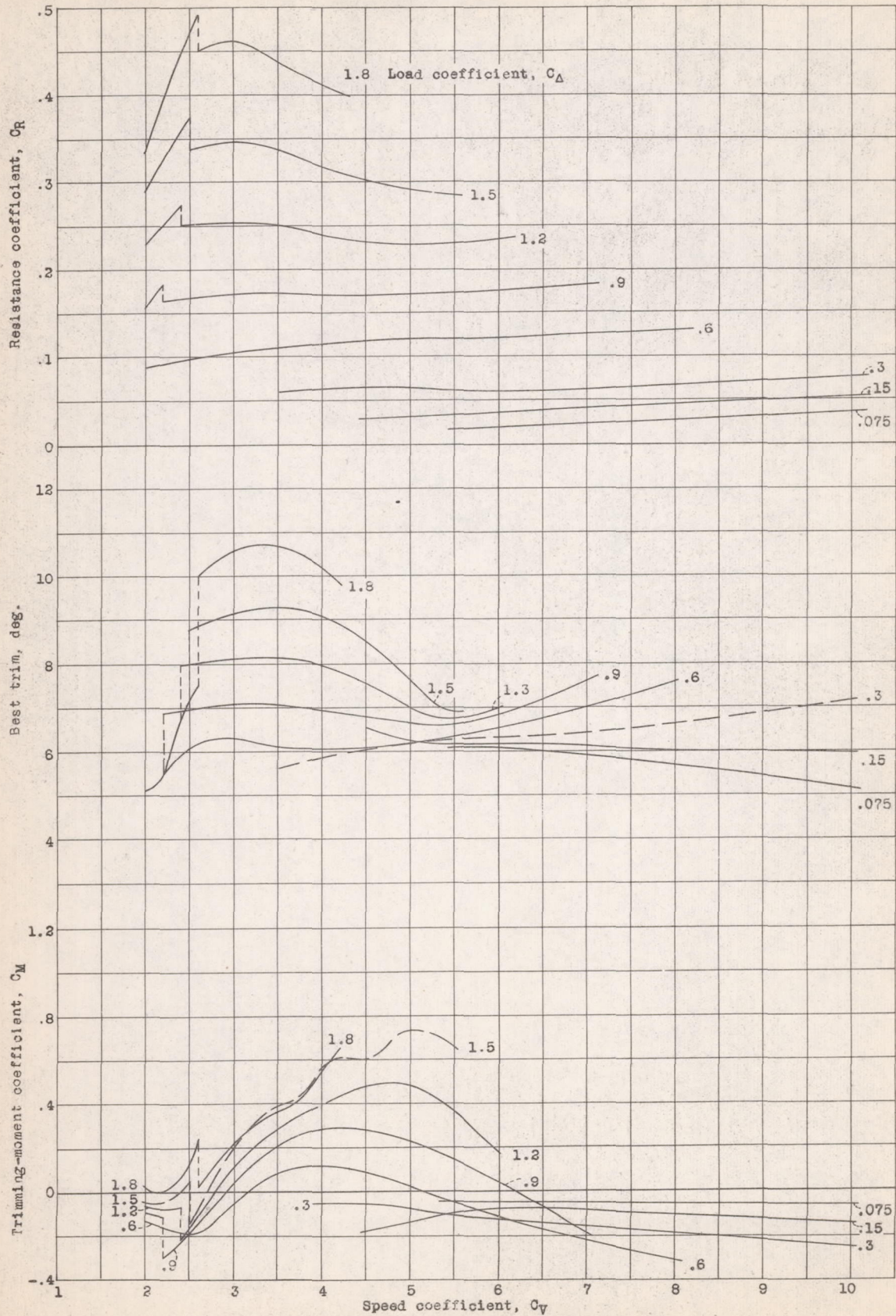

Figure 37.- Model 61-A. Characteristics at best trim with forebody in the water.

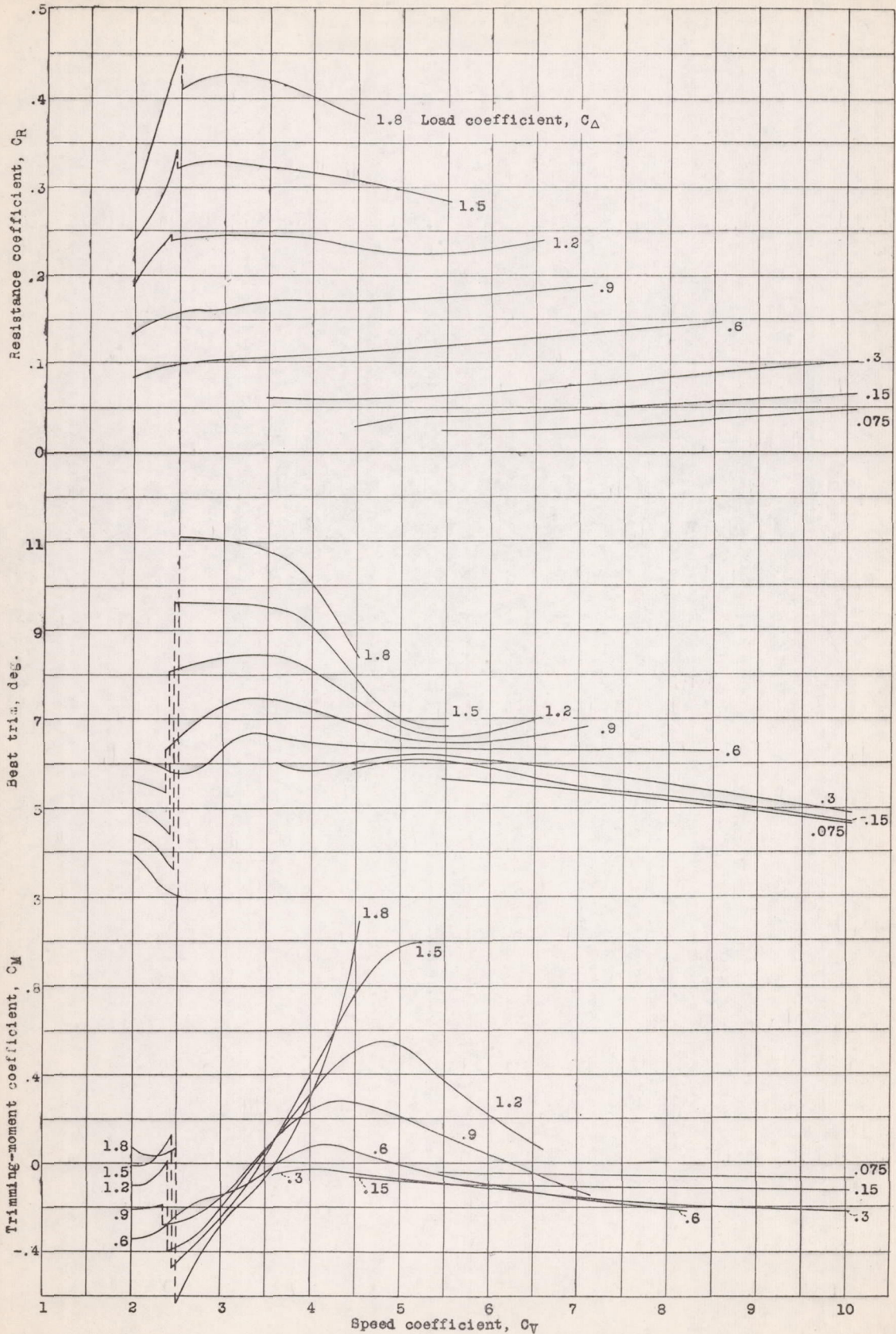

Figure 38.- Model 73. Characteristics at best trim with forebody in the water.

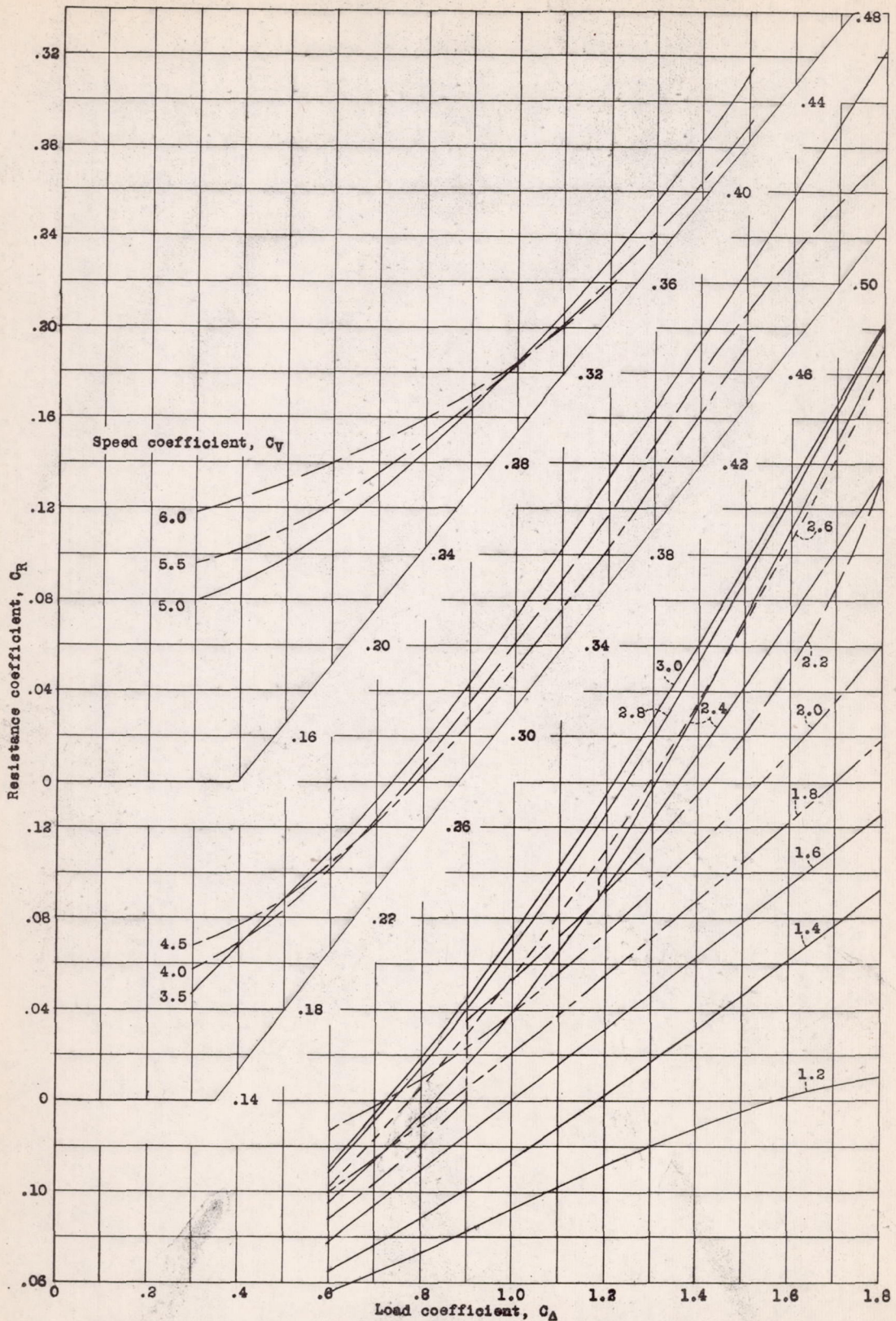

Figure 39.- Model 41-D. Chart for determination of resistance at zero trimming moment.

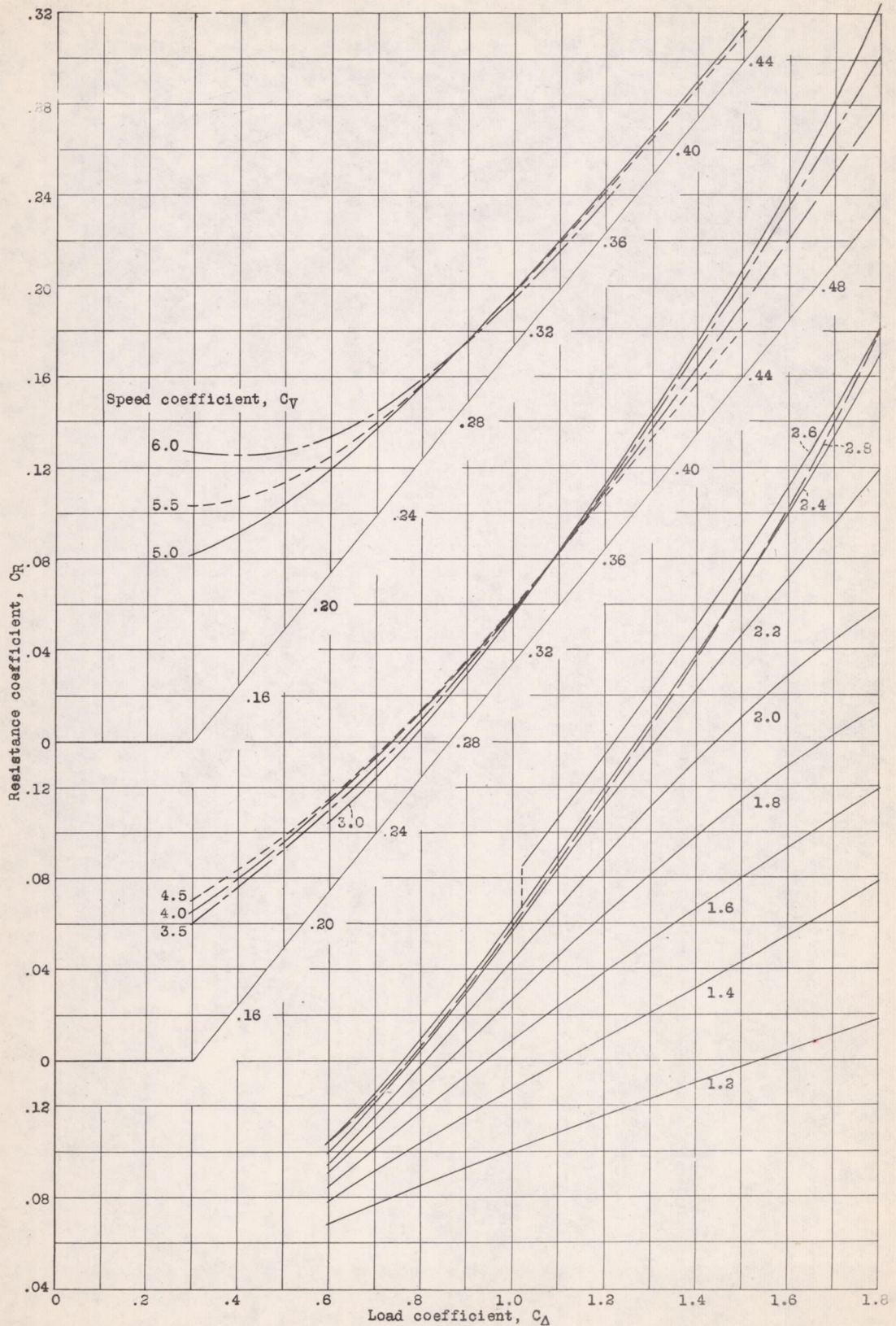

Figure 40.- Model 61-A. Chart for determination of resistance at zero trimming moment.

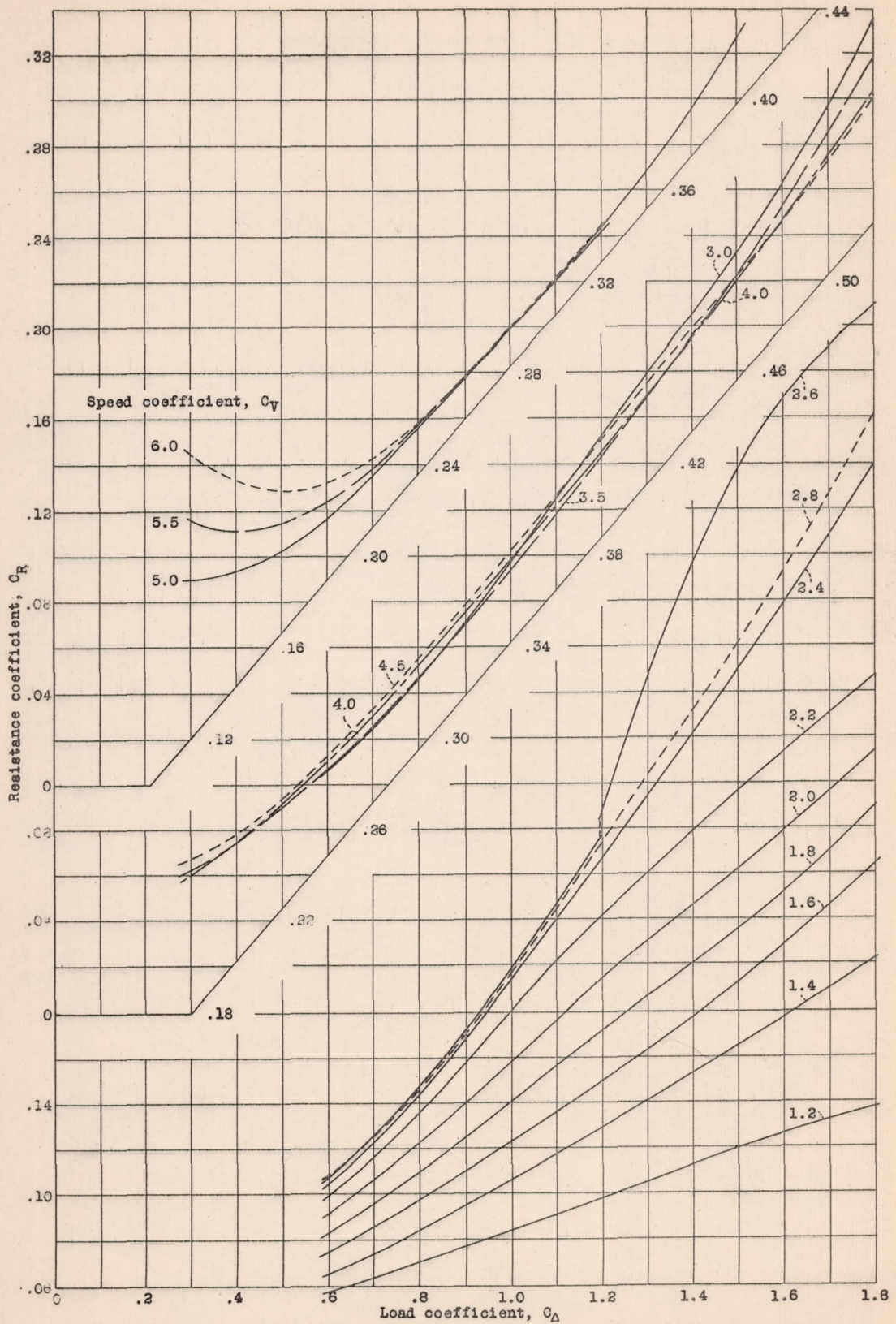

Figure 41.- Model 73. Chart for determination of resistance at zero trimming moment.

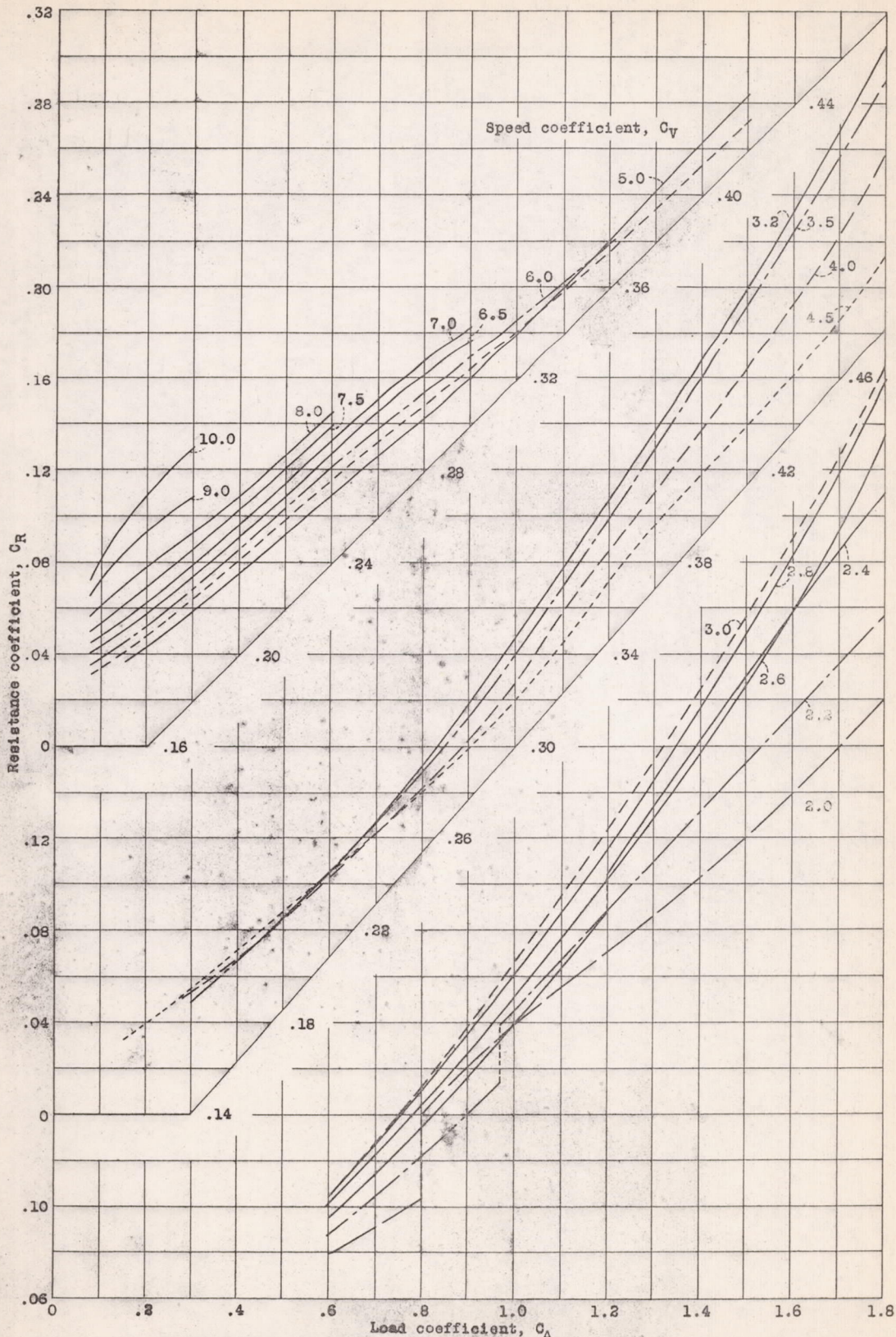

Figure 42.- Model 41-D. Chart for determination of resistance at best trim with forebody in the water.

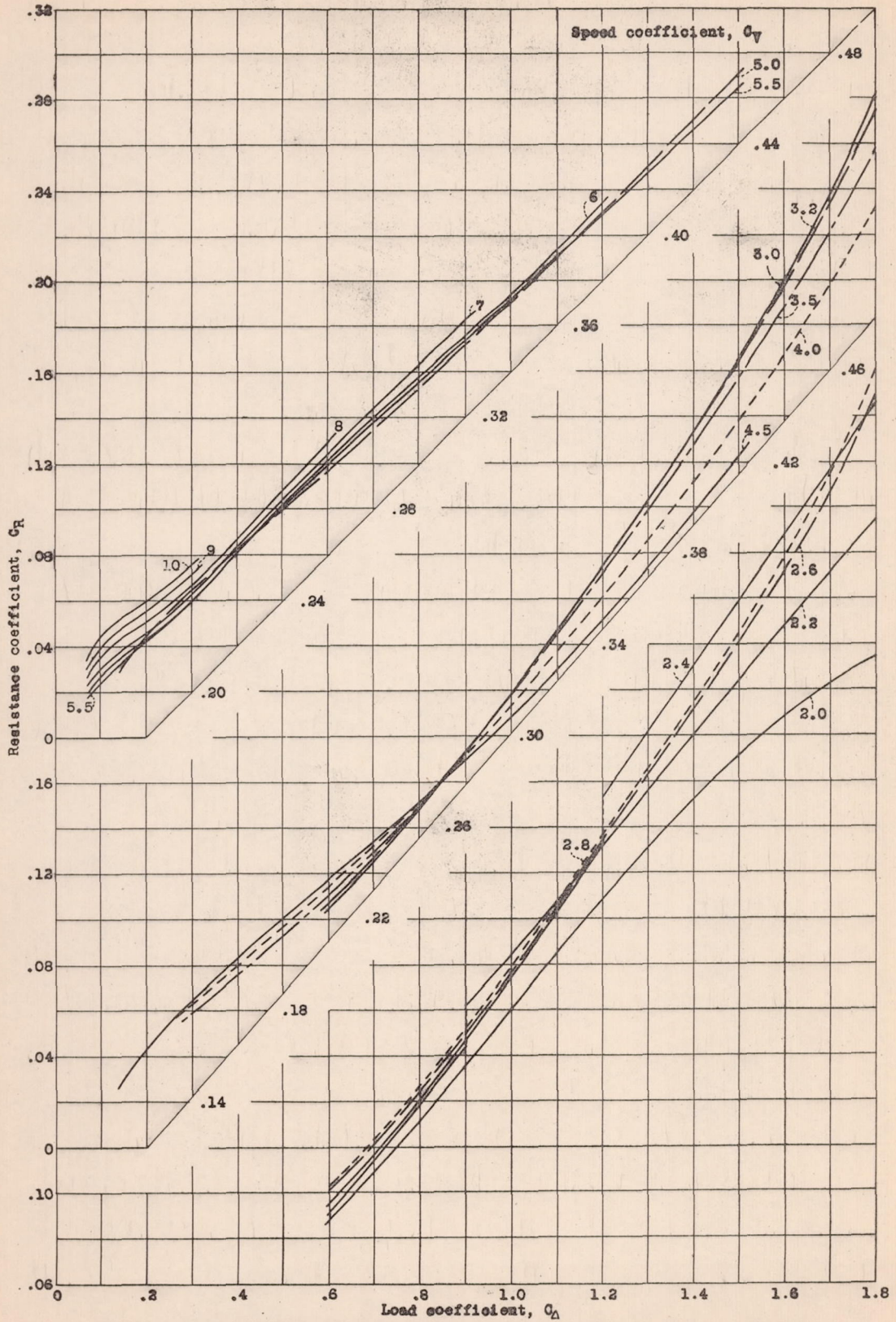

Figure 43.- Model 61-A. Chart for determination of resistance at best trim with forebody in the water.

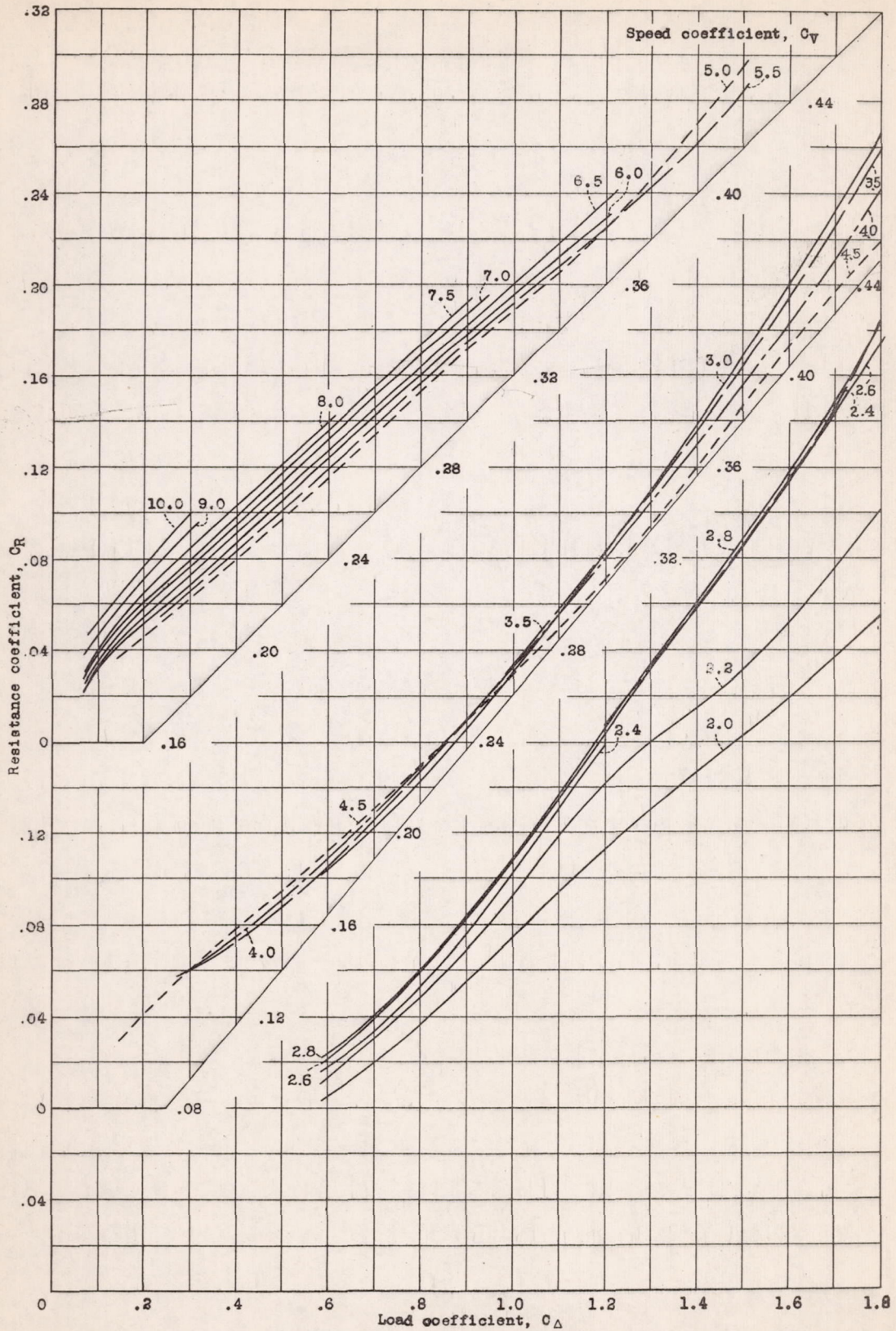

Figure 44.- Model 73. Chart for determination of resistance at best trim with forebody in the water.

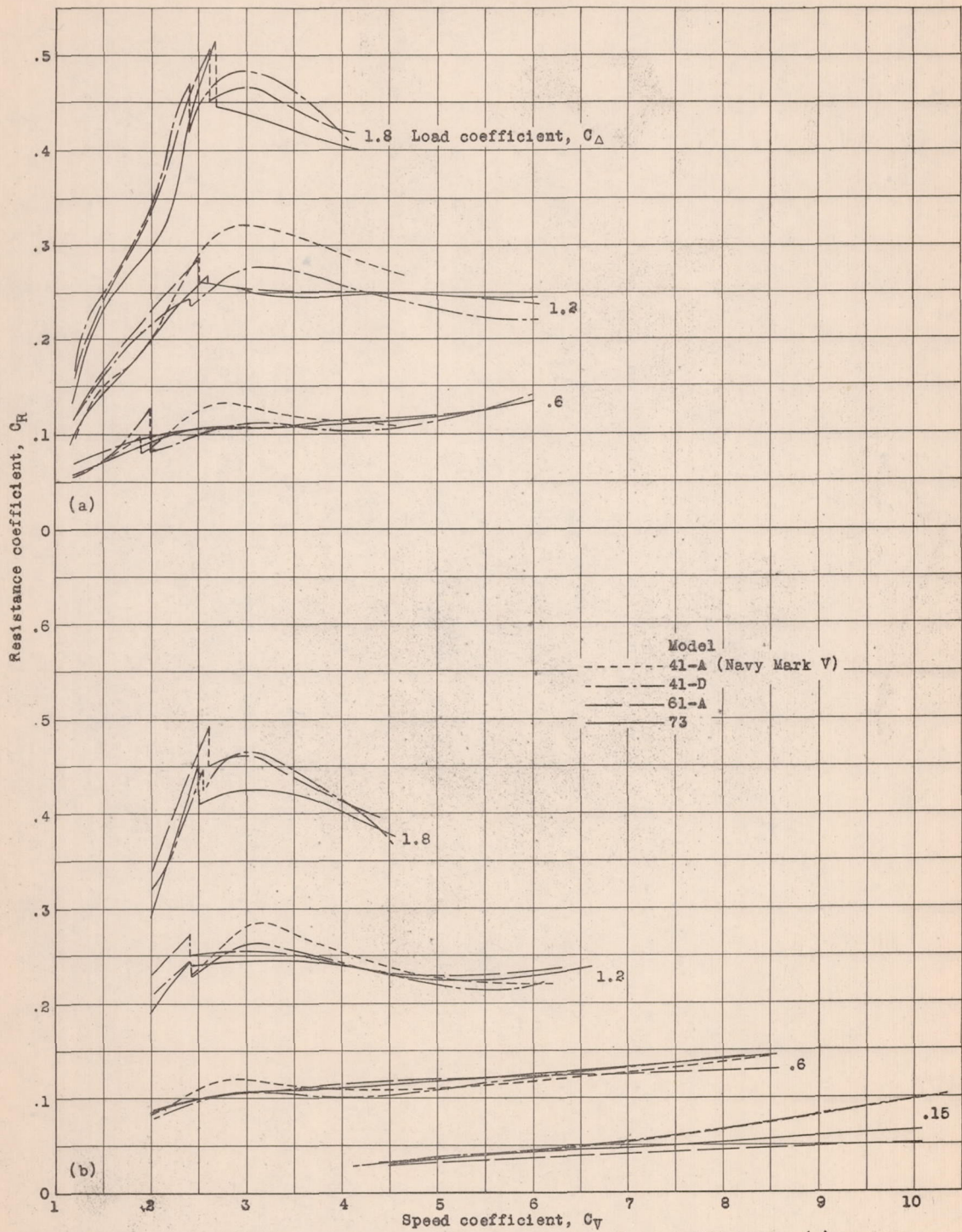

Figure 45a,b.- Comparisons of resistance coefficient at various load coefficients. (a) at zero trimming moment. (b) at best trim.

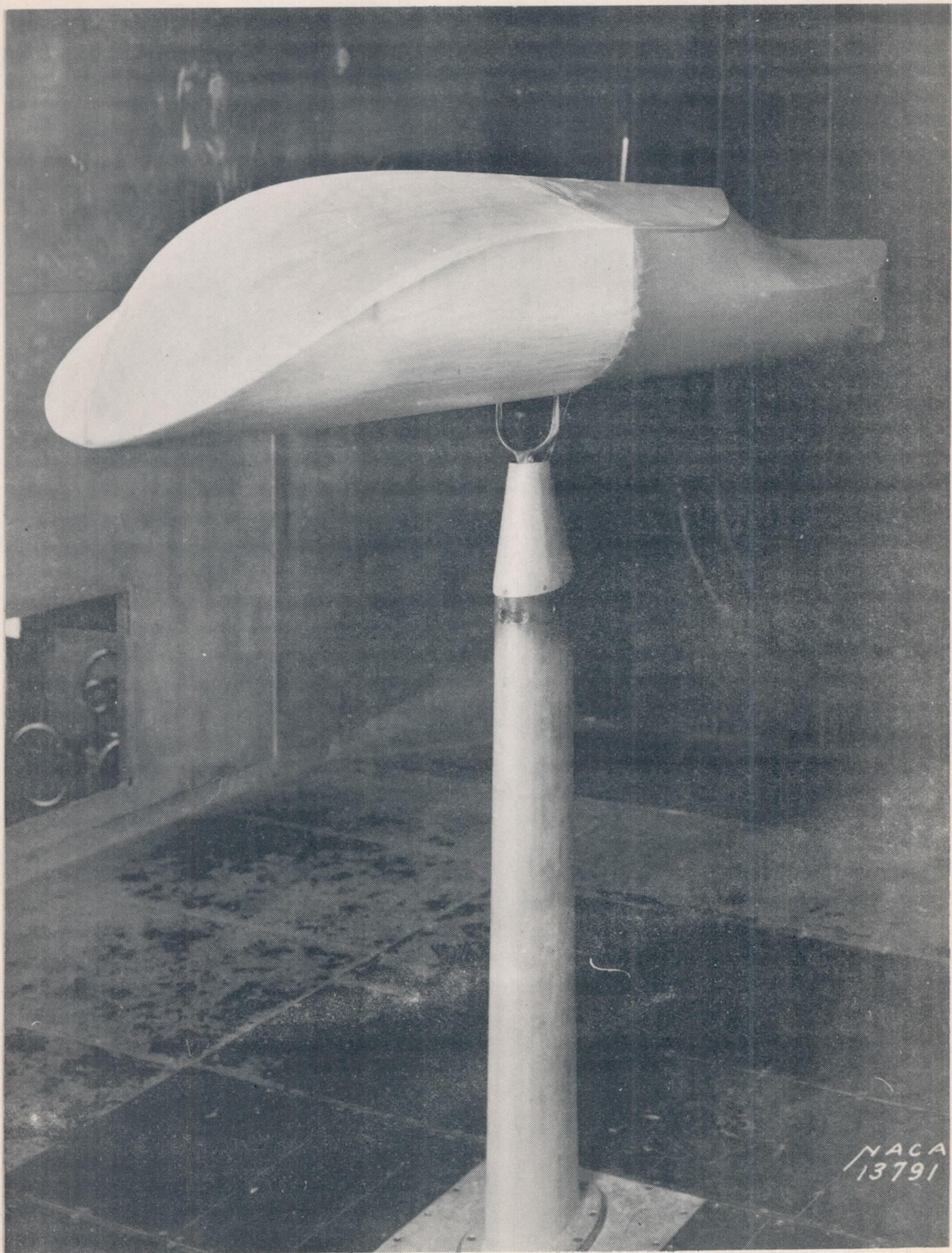

Figure 46.- Model 73-A mounted in the wind tunnel.

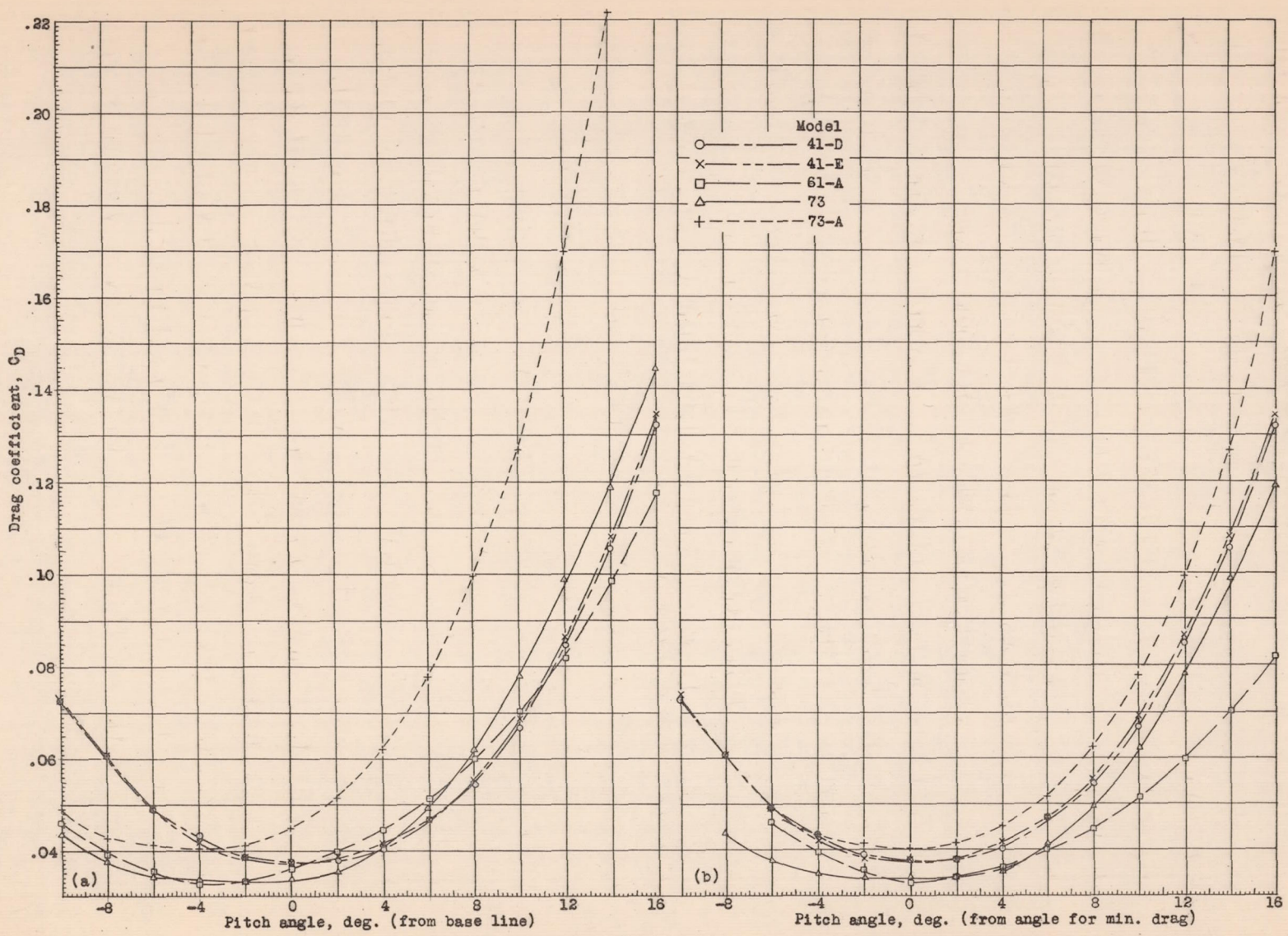

Figure 47a,b.- Variation of air drag coefficient C_D with angle of pitch.