

National Advisory Committee  
for Aeronautics

X705

GOVT. DOC.

MAILED

MAY 10 1939

To Library, *Hartford Public*

TECHNICAL NOTES

NATIONAL ADVISORY COMMITTEE FOR AERONAUTICS

-----  
No. 705  
-----

WIND-TUNNEL INVESTIGATION OF GROUND EFFECT  
ON WINGS WITH FLAPS

By Isidore G. Recant  
Langley Memorial Aeronautical Laboratory

-----

Washington  
May 1939

BUSINESS, SCIENCE  
& TECHNOLOGY DEPT.



NATIONAL ADVISORY COMMITTEE FOR AERONAUTICS

-----  
TECHNICAL NOTE NO. 705  
-----

WIND-TUNNEL INVESTIGATION OF GROUND EFFECT  
ON WINGS WITH FLAPS

By Isidore G. Recant

SUMMARY

An investigation was conducted in the N.A.C.A. 7- by 10-foot wind tunnel to determine the effect of ground proximity on the aerodynamic characteristics of wings equipped with high-lift devices. A rectangular and a tapered wing were tested without flaps, with a split flap, and with a slotted flap. The ground was represented by a flat plate, completely spanning the tunnel and extending a considerable distance ahead and back of the model. The position of the plate was varied from one-half to three chord lengths below the wing.

The results are presented in the form of curves of absolute coefficients, showing the effect of the ground on each wing arrangement. The effect of the ground on lift, drag, and pitching moment is discussed. An appendix gives equations for calculating tunnel-wall corrections to be applied to ground-effect tests conducted in rectangular tunnels when a plate is used to represent the ground.

The tests indicated that the ground effect on wings with flaps is a marked decrease in drag, a decrease in diving moment, and a substantial reduction in maximum lift.

INTRODUCTION

The phenomenon commonly called "ground effect," whereby the aerodynamic characteristics of plain wings undergo marked changes in the presence of the ground, has been subject to considerable investigation (references 1 and 2). Both theory (reference 3) and experiment (references 4, 5, and 6) indicate that the proximity of the ground decreases the drag and increases the slope of the lift curve in the same manner as an increase in aspect ratio would affect the



same factors. In fact, it is customary to predict the effect of the ground on the basis of an apparent increase in aspect ratio (references 3 and 5). Although a wing operating in the vicinity of the ground is subjected to an increase in lift over the free-air value at any given angle of attack, it does not necessarily follow that the maximum lift coefficient is increased. Available evidence indicates that, for wing heights decreasing from infinity to one-half chord length, the maximum lift is unaffected (references 3 and 5) or slightly decreased (references 4, 7, and 8).

Much less study has been devoted to the effect of the ground on airfoils equipped with lift-increasing devices. Viaud (reference 9) found the customary increase in the slope of the lift curve and decrease in the drag for wings with various types of flap. The maximum lift for split and plain trailing-edge flaps increased as the wing approached the ground. For the slotted flap, the maximum lift remained nearly constant; whereas, for the multiple slotted flap, the maximum lift decreased considerably as the ground was approached. For split flaps of the Zap type, Serebrijsky (reference 10) found a decrease in the maximum lift as the ground was approached.

Since almost all present-day airplanes are provided with flaps of one type or another and since the flap effect is of particular importance in the immediate vicinity of the ground, the necessity for further study of the problem is obvious.

The present investigation was made in the N.A.C.A. 7-by 10-foot wind tunnel to study the effect of a simulated ground area on a rectangular and a tapered wing, each equipped successively with full-span split and slotted flaps. It may be pointed out that the tests were run at a comparatively small scale, and the method of ground simulation is not exactly representative of actual flight conditions. Nevertheless, the results are believed to be indicative of the comparative effects on the various devices, but flight tests are required to determine the applicability of the wind-tunnel results.



## APPARATUS AND TESTS

## Models

The wing models used have the N.A.C.A. 23012 profile and are made of laminated mahogany. They have a span of 60 inches, a geometric aspect ratio of 6, and an average chord of 10 inches (fig. 1). They had been used in a previous investigation (reference 11) and were available for the present tests.

The tapered wings (fig. 2) have a root chord of 16.67 inches and are tapered 5:1. The maximum ordinates of all sections on the upper surface are in a horizontal plane and the plan form is symmetrical about a line perpendicular to the root chord at its 50-percent point.

The split-flap models are shown in figures 1(b) and 2(b). The flaps are full span; their chords are 20 percent of the wing chord; and they are located at 80 percent of the wing chord. The flaps were set at  $60^\circ$ , which is the deflection necessary for maximum lift. On the tapered wing the flap also has a taper of 5:1.

The slotted-flap models are shown in figures 1(c) and 2(c). This flap is designated 2-h in reference 12, which gives the slot shape, the flap profile, and the path of the flap nose for various deflections. The flap chord is 25.56 percent of the wing chord and the deflection is  $40^\circ$ , which is the angle necessary for maximum lift. On the tapered wing the flap also has a taper of 5:1.

## Wind Tunnel

The tests were made in the N.A.C.A. 7- by 10-foot closed-throat wind tunnel described in reference 12. The model was mounted on the regular 6-component balance (reference 13) that measures the aerodynamic forces and moments independently and simultaneously with respect to the wind axes of the model.

## Ground Representation

The most common methods of ground representation are the flat-plate and the reflection methods. These methods are compared by Raymond (reference 6) and Cowley and Lock



(reference 14); both references show a discrepancy between the two methods. Cowley and Lock impute the discrepancy to a shift in the angle of zero lift that is due to the deflection of the air stream by the plate, but Raymond's tests also show a shift in zero lift with the reflection method.

In the present tests the ground was simulated by a flat plate. The most obvious objection to the plate is the fact that the air moves with respect to it, creating a boundary layer; such a condition does not exist in actual flight. A survey of the boundary layer over the plate, however, showed the maximum thickness under the trailing edge of the wing to be about 1 inch. Since the models were always at least 2 inches from the plate, it is unlikely that the results were greatly affected. The present tests, moreover, are comparative and, under these circumstances, the plate method is considered valid.

The plate is made of 3/8-inch plywood, is 7 feet long and 10 feet wide, completely spanning the tunnel width. The leading edge of the plate has a faired nosepiece 4 inches long and 2 inches thick. The plate was fastened to a steel frame; vertical steel rods passed through the plate and the frame at each corner and were rigidly attached to the tunnel floor and roof. The plate was free to slide on the rods in order to vary the distance from it to the wing, which was mounted on the tunnel center line. The plate was held in any desired position by set screws that clamped it to the vertical rods. Two vertical rods under the plate at its longitudinal center line kept it from sagging. The model was mounted about four chord lengths back of the leading edge of the plate. Figure 3 shows the plate and the method of mounting it in the tunnel.

#### Tests

Dynamic-pressure surveys at the location of the model were made for each position of the ground plate. The dynamic pressure was maintained constant throughout the tests at 16.37 pounds per square foot, corresponding to an air speed of 80 miles per hour at standard sea-level conditions. The average test Reynolds Number was 609,000 based on a mean wing chord of 10 inches. The effective Reynolds Number due to the turbulence of the tunnel was approximately 974,000. A survey of the boundary layer over the plate at the trailing edge of the wing was made.



The rectangular and the tapered wings were tested plain and then successively with full-span split flaps and full-span slotted flaps. Each arrangement was tested in the clear tunnel and then with the ground plate at one-half, one, two, and three chord lengths below the wing. Distances were measured from the quarter-chord point of the model to the ground plate. Lift, drag, and pitching moments were measured for an angle-of-attack range from  $-6^\circ$  to the stall in  $2^\circ$  increments.

## RESULTS AND DISCUSSION

### Coefficients and Symbols

The results are given in absolute nondimensional coefficient form.

$C_L$ , lift coefficient  $(L/qS)$ .

$C_D$ , drag coefficient  $(D/qS)$ .

$C_{m(a.c.)_o}$ , pitching-moment coefficient about aerodynamic center of plain wing  $(M_{(a.c.)_o}/qc_w S)$ .

where

$L$  is lift.

$D$ , drag.

$M_{(a.c.)_o}$ , pitching moment about aerodynamic center of plain wing.

$S$ , wing area.

$c_w$ , mean geometric chord of airfoil with flap fully retracted.

$q$ , dynamic pressure  $(\frac{1}{2} \rho V^2)$ .

and  $\alpha$  is angle of attack.

$\delta_f$ , flap deflection.

$h$ , distance of quarter-chord point from ground.



### Ground Distance

The distance of the wing from the ground is expressed as a ratio  $h/c_w$ , where  $h$  is the distance from the ground to the quarter-chord point of the wing. The choice of the reference point from which to measure the ground distance is somewhat arbitrary and varies with different investigators. The nose of the wing was chosen in reference 9; the quarter-chord point was used in references 6 and 7; the half-chord point was used in references 3 and 8; and Dätwyler, whose work is summarized in references 1 and 2, chose the trailing edge. Regardless of the point selected, the ground distance will evidently vary as the angle of attack is changed unless the wing is rotated about that point in changing the angle. For long ground distances, the choice of reference point is not likely to make any appreciable difference in the results. For short ground distances, however, different results may be expected for each reference point chosen. Since the lift caused by the change in the angle of attack acts at approximately the quarter-chord point and the lift that is due to the wing curvature acts at about the half-chord point (reference 15), the quarter-chord point seems convenient as a reference. When the quarter-chord point is used as a reference point, the ground distance to the point of action of the lift that is due to the angle of attack will not change and the ground distance to the point of action of the lift that is due to the curvature will change only slightly with a change in the angle of attack. No substantiated theory indicates any one reference point to be preferable, but it is well to keep in mind the reference points used when test results are compared.

### Wind-Tunnel Corrections

The tests run without the ground plate in the tunnel were corrected for tunnel effect to aspect ratio 6 in free air. The normal jet-boundary corrections were applied (reference 11). The tests run with the ground plate in the various positions below the wing were not corrected because the tunnel-wall interference factors calculated for these conditions were small enough to be disregarded. The method of calculating the interference factors for the ground-board installation is given in the appendix.



## Precision

Experimental errors in the results presented in this report are believed to be within the following limits:

|                 |           |                                       |
|-----------------|-----------|---------------------------------------|
| $\alpha$        | - - - - - | $\pm 0.1^\circ$                       |
| $C_L$           | - - - - - | $\pm 0.001$                           |
| $C_{L_{max}}$   | - - - - - | $\pm 0.005$                           |
| $C_D$           | - - - - - | $\pm 0.001$                           |
| $C_{D_{min}}$   | - - - - - | $\pm 0.0005$ ( $\delta_f = 0^\circ$ ) |
| $C_{m(a.c.)_0}$ | - - - - - | $\pm 0.001$                           |
| $\delta_f$      | - - - - - | $\pm 1.0^\circ$                       |
| $h$             | - - - - - | $\pm 1/16$ inch                       |

The ground plate was parallel to the tunnel axis within  $\pm 0.1^\circ$ .

No tests were made to determine the effect of the flap fittings. Because the tests are comparative, the effect of the fittings would probably not materially change the results.

## Aerodynamic Effects of the Proximity of the Ground

Lift-curve slope.- The effect of the ground on the slope of the lift curve is shown in figures 4 to 9. For the plain wings (figs. 4 and 5) the slope increases as the ground distance decreases. In general, this effect is in agreement with the Wieselsberger theory (reference 3). The increase, especially for the shorter ground distances, is numerically greater than predicted by the theory. This discrepancy may be due to the fact that the theory is based only on the effect of the trailing-vortex system and neglects the effect of streamline curvature due to the ground. (See references 7 and 8.) This effect will tend to increase the slope further. Reference 7 gives theoretical equations that indicate an increase in the angle of zero lift as the ground is approached; this increase is due to the thickness of the wing. The present tests show no such shift.



For the wings with the slotted and the split flaps (figs. 6 to 9), the lift curves in general appear to be parallel but displaced from each other as the ground distance decreases. These tests, however, were not run below a lift coefficient of 0.6; and, if no shift in the angle of zero lift (as is indicated by the plain-wing tests) is assumed, the slopes below  $C_L = 0.6$  would increase with a decrease in ground distance.

Drag.— The effect of the ground on drag is shown in figures 4 to 9. As indicated by theory, the drag for all the wing arrangements was substantially reduced as the ground distance decreased. The reduction in drag of the plain wings is somewhat greater than the theoretical estimate that is based solely on an apparent increase in the aspect ratio; whereas, the reduction for the wings with flaps averages 40 percent greater than Wieselsberger's theory indicates. The results of Raymond (reference 6) as well as those of Cowley and Lock (reference 14) tend to show that the plate method of ground representation gives a greater decrease in drag than does the reflection method. It is doubtful, however, that the discrepancy between Wieselsberger's theory and the present tests is entirely due to the method of ground representation, as Le Sueur (reference 1), using the reflection method, reports similar discrepancies with the theory. It is likely that the difference between the theoretical and the experimental results is due to the fact that the Wieselsberger theory neglects the effect of flow curvature and the change in the longitudinal velocity (reference 7) that are due to the presence of the ground.

Maximum lift.— The effect of the ground on maximum lift is shown in figures 10 and 11. For the plain wings,  $C_{L_{max}}$  is nearly constant to within two chord lengths from the ground. As the distance becomes less, the lift drops slightly. At still shorter distances the lift begins to increase. This increase is probably a manifestation of the effect reported by Datwyler (see references 1 and 2) whereby, for very small distances,  $C_{L_{max}}$  increases rapidly. For all practical purposes, however, the present tests indicate that the maximum lift of plain wings is little affected by the presence of the ground.

For the wings with flaps, the maximum lift is substantially decreased as the distance from the ground decreases (fig. 10). The decrease is greater for the slotted-flap



wings than for the split-flap wings. At  $h/c_w = 0.7$ , the  $C_{L_{max}}$  of the rectangular slotted-flap wing is decreased 21 percent, whereas the  $C_{L_{max}}$  of the rectangular split-flap wing is decreased 18.5 percent. For either type of flap, the decrease in lift is greater for the rectangular than for the tapered wing; the lift of the tapered slotted-flap wing is reduced 12.5 percent, and that of the tapered split-flap wing 8.7 percent.

The trailing edges of the wings with flaps were considerably closer to the ground plate than the trailing edges of the plain wing because of the flap deflections. It is therefore possible that the wings with the flaps are more greatly affected by the boundary layer and this effect caused the greater loss in the lift. The tests by Dätwyler indicate, however, that the lift increases rather than decreases as the trailing edge approaches the plate.

For a constant distance from the ground, the decrease in  $C_{L_{max}}$  might be expected to be a function of the  $C_{L_{max}}$  that the wing possesses in free air. (See fig. 11.) It is evident from figure 11, however, that the free-air value of  $C_{L_{max}}$  is not the only factor involved; otherwise, the curve for the tapered wing would coincide with the one for the rectangular wing.

The theoretical work reported in reference 7 probably does not apply to the maximum lift of a wing nor to a wing equipped with flaps; nevertheless, it does suggest the nature of ground effect. For a given height, the ground effect may be broken down into the following:

1. Flow-curvature effect, which in most cases tends to increase the lift for a given angle of attack and is very nearly a function of  $(C_L - KC_L^2)$ .
2. Wing-thickness effect, which tends to decrease the lift and is constant for a fixed height.
3. Induced longitudinal-velocity effect, which tends to decrease the lift for a given angle and is a function of  $C_L^2$ .
4. Trailing-vortices effect, which tends to increase the lift for a given angle of attack and is a function of  $C_L$ .



For the plain wings, the trailing-vortices effect is most likely to be predominant; whereas, for the wings with flaps with their considerably higher lift coefficients, the induced longitudinal-velocity effect, varying as the square of the lift coefficient, probably takes precedence and causes a loss in lift.

Lift-drag ratio at maximum lift.- The effect of the ground on the lift-drag ratio at maximum lift is shown in figure 12. The approach of the ground increases the value of  $L/D$  sharply for all wings. The increase in the  $L/D$  of the wings with flaps caused by the ground, in spite of the decrease in the lift, indicates how markedly the drag is decreased. The similarity in the shapes of the curves of figure 12 indicates that the phenomenon of "floating" is to be expected on airplanes equipped with flaps as well as on those without flaps.

Pitching moment.- The effect of the ground on the pitching moment is shown in figures 4 to 9. For the plain wings, the change in pitching moment due to the ground is not large. For a given angle of attack, the diving moment increases as the ground distance decreases. For the wings with flaps (especially the rectangular wings), the effect of the ground is quite marked. The diving moment is decreased and the slope of the moment curves is increased. If the change in the lift is caused by the ground, the change in the moment is to be expected.

## CONCLUSIONS

The tests reported herein showed that:

1. The approach of the ground increased the slope of the lift curves of the plain wings but had little effect on the slope of the curves of the wings with flaps over the range of angles of attack tested.
2. The approach of the ground reduced the drag of all the wings tested; the magnitude of the reduction varied with the lift coefficient.
3. The approach of the ground had small effect on the pitching moments of the plain wings but decreased the diving moments of the wings equipped with split or slotted flaps.



4. The approach of the ground had almost no effect on the maximum lift of the plain wings but reduced the maximum lift coefficient of the wings equipped with split or slotted flaps.

5. The reduction in the maximum lift coefficient was greater for rectangular wings with flaps than for tapered wings with flaps.

6. The reduction in the maximum lift coefficient was greater for wings equipped with slotted flaps than for wings equipped with split flaps.

Langley Memorial Aeronautical Laboratory,  
National Advisory Committee for Aeronautics,  
Langley Field, Va., March 11, 1939.

#### APPENDIX

##### Tunnel-Wall Corrections for Test Installation Used

When ground-effect tests are made in a wind tunnel, the question of tunnel-wall interference corrections always arises. Some investigators have used no correction; others have used the standard form of correction. In an effort to determine their magnitude, the corrections were calculated from the theoretical equations given in references 16 and 17.

The general problem for a wind tunnel is the determination of a stream function that, when added to the flow produced by the airfoil in an unlimited stream, satisfies the conditions existing at the boundaries of the air stream. The boundaries may be replaced by the stream function and the effect on the airfoil computed.

In the case of ground effect, it is desired to determine a stream function that, when added to the flow produced by the airfoil operating near an infinite plane, will satisfy the boundary conditions.

Thus, if the floor of the tunnel represents the ground and if the function that represents the effect of the ground plane is deducted from the stream function that satisfies the conditions for the boundaries of a closed rectangular tunnel, the remainder should give the correction due to the tunnel walls.



In the present tests, the wing was mounted in the center of the tunnel and the ground plane was moved to vary the distance of the wing from the ground. Thus, at each position of the ground plane, there was, in effect, a new tunnel with a new height-to-width ratio and a different distance from the wing to the tunnel center line. These conditions are shown in figure 13.

Now, if a closed rectangular tunnel with a wing displaced from the center is considered, an infinite pattern of images may be arranged to satisfy the boundary conditions (reference 16). Such a system is shown in figure 14.

According to reference 16, the equation for the interference due to the system of vortices symmetrical about line A-A is:

$$\delta_1 = - \frac{1}{4\pi r \sigma^2} \left[ \log \frac{\sinh \frac{\pi r \sigma}{2}}{\frac{\pi r \sigma}{2}} + \sum_1^{\infty} \log \left( 1 - \frac{\sinh^2 \frac{\pi r \sigma}{2}}{\sinh^2 \frac{\pi r n}{2}} \right) \right] \quad (1)$$

where

$$r = b/h$$

$$\sigma = 2s/b$$

and  $h$  is height of tunnel.

$b$ , width of tunnel.

$s$ , semispan of wing.

The equation for the interference caused by the system of vortices symmetrical about line B-B is:

$$\delta_2 = \frac{1}{8\pi r \sigma^2} \left[ \log \frac{\left[ \cosh \pi r \sigma + \cos 2\pi r \frac{d}{b} \right]}{\left[ 1 + \cos 2\pi r \frac{d}{b} \right]} + \sum_1^{\infty} \log \frac{\left[ \cosh \pi r (n+\sigma) + \cos 2\pi r \frac{d}{b} \right] \left[ \cosh \pi r (n-\sigma) + \cos 2\pi r \frac{d}{b} \right]}{\left[ \cosh \pi n r + \cos 2\pi r \frac{d}{b} \right]^2} \right] \quad (2)$$



where  $d$  is the distance of the wing from the center line.

The correction for the complete tunnel is then  $\delta_1 + \delta_2$ .

In order to eliminate the effect of the ground plane, the effect of the single ground image  $C_1 - C_2$  is calculated as follows. (See fig. 14.)

The vertical velocity  $v_1$  at any point  $F$  on the real wing due to vortex  $C_1$  of strength  $\Gamma$  is:

$$\begin{aligned} v_1 &= \frac{\Gamma}{4\pi} \frac{1}{\sqrt{(x+s)^2 + (h-2d)^2}} \frac{(x+s)}{\sqrt{(x+s)^2 + (h-2d)^2}} \\ &= \frac{\Gamma}{4\pi} \frac{(x+s)}{(x+s)^2 + (h-2d)^2} \end{aligned}$$

The vertical velocity  $v_2$  at the point  $F$  due to vortex  $C_2$  of strength  $\Gamma$  is:

$$\begin{aligned} v_2 &= \frac{\Gamma}{4\pi} \frac{1}{\sqrt{(s-x)^2 + (h-2d)^2}} \frac{s-x}{\sqrt{(s-x)^2 + (h-2d)^2}} \\ &= \frac{\Gamma}{4\pi} \frac{s-x}{(s-x)^2 + (h-2d)^2} \end{aligned}$$

The total vertical velocity  $v_T$  at  $F$  is

$$v_T = v_1 + v_2 = \frac{\Gamma}{4\pi} \frac{x+s}{(x+s)^2 + (h-2d)^2} + \frac{\Gamma}{4\pi} \frac{s-x}{(s-x)^2 + (h-2d)^2}$$

The downflow over the entire span is:



$$\begin{aligned}
 D &= \int_{-s}^s v_T dx \\
 &= \frac{\Gamma}{4\pi} \int_{-s}^s \frac{x+s}{(x+s)^2 + (h-2d)^2} + \frac{\Gamma}{4\pi} \int_{-s}^s \frac{s-x}{(s-x)^2 + (h-2d)^2} \\
 &= \frac{\Gamma}{8\pi} \left\{ \log \left[ \frac{(x+s)^2 + (h-2d)^2}{(s-x)^2 + (h-2d)^2} \right] \right\}_{-s}^s \\
 &= \frac{\Gamma}{8\pi} \left[ \log \frac{(x+s)^2 + (h-2d)^2}{(s-x)^2 + (h-2d)^2} \right]_{-s}^s \\
 &= \frac{\Gamma}{8\pi} \log \frac{[4s^2 + (h-d)^2]^2}{(h-2d)^4}
 \end{aligned}$$

or

$$D = \frac{\Gamma}{8\pi} \psi$$

where

$$\psi = \log \frac{[4s^2 + (h-d)^2]^2}{(h-2d)^4}$$

From the relation

$$\Gamma 2s \rho V = \frac{1}{2} C_L \rho V^2 S$$

where  $V$  is velocity;  $\rho$ , density; and  $S$ , area of the airfoil, is obtained

$$\Gamma = \frac{C_L V S}{4s}$$

Therefore,

$$D = \frac{C_L V S}{32\pi S} \psi$$



$$\Delta \alpha = \frac{v_T}{V} = \frac{D}{2sV} = \frac{C_L S}{64\pi s^2} \psi = \frac{C_L S}{64\pi s^2} \frac{bh}{bh} \psi = \delta_3 \frac{C_L S}{C}$$

$$\delta_3 = \frac{bh}{64\pi s^2} \psi = \frac{1}{16\pi\sigma^2 r} \psi$$

$$\delta_3 = \frac{1}{16\pi\sigma^2 r} \log \frac{[4s^2 + (h - 2d)^2]^2}{(h - 2d)^4}$$

or

$$\delta_3 = \frac{1}{16\pi\sigma^2 r} \log \frac{\left[ \sigma^2 + \left( \frac{1}{r} - \frac{2d}{b} \right)^2 \right]^2}{\left( \frac{1}{r} - \frac{2d}{b} \right)^4} \quad (3)$$

The net correction is then

$$\delta_1 + \delta_2 - \delta_3 = \delta_N$$

and

$$\Delta \alpha = \delta_N \frac{S}{C} C_L \times 57.3$$

$$\Delta C_D = \delta_N \frac{S}{C} C_L^2$$

where  $S$  is the wing area.

$C$ , the tunnel cross-sectional area.

Figure 13 gives the correction factors for the various positions of the ground plane. It can be seen that most of the tunnel interference is due to the ground plane, especially when the distance from the wing to the ground is short and that, when the ground-plane correction,  $\delta_3$ , is subtracted from the total tunnel correction ( $\delta_1 + \delta_2$ ), the net correction,  $\delta_N$ , is so small as to be negligible.

## REFERENCES

1. Le Sueur, Maurice: Ground Effect on the Take-Off and Landing of Airplanes. T.M. No. 771, N.A.C.A., 1935.
2. Pistolesi, E.: Ground Effect - Theory and Practice. T.M. No. 828, N.A.C.A., 1937.
3. Wieselsberger, C.: Wing Resistance near the Ground. T.M. No. 77, N.A.C.A., 1922.
4. Tonnes, E.: Effect of the Ground on an Airplane Flying Close to It. T.M. No. 674, N.A.C.A., 1932.
5. Reid, Elliot G.: A Full-Scale Investigation of Ground Effect. T.R. No. 265, N.A.C.A., 1927.
6. Raymond, Arthur E.: Ground Influence on Aerofoils. T.N. No. 67, N.A.C.A., 1921.
7. Tani, Itiro, Taima, Masuo, and Simidu, Sodi: The Effect of Ground on the Aerodynamic Characteristics of a Monoplane Wing. Report No. 156, (vol. XIII, 2.), Aero. Res. Inst., Tokyo Imperial Univ., Sept. 1937.
8. Tomotika, Susumu, Nagamiya, Takeo, and Takenouti, Yositada: The Lift on a Flat Plate Placed near a Plane Wall, with Special Reference to the Effect of the Ground upon the Lift of a Monoplane Aerofoil. Report No. 97, (vol. VIII, 1.), Aero. Res. Inst., Tokyo Imperial Univ., Aug. 1933.
9. Viaud, Louis: Étude en soufflerie des caractéristiques aérodynamiques de quelques dispositifs hypersustentateurs placés au voisinage du sol. Comptes Rendus: Tome 206, No. 25, 20 June 1938, pp. 1877-80; and Tome 207, No. 1, 4 July 1938, pp. 37-39.
10. Serebrijsky, I.: Ground Effect on the Aerodynamical Characteristics of an Aeroplane (in Russian). Report No. 267, Central Aero-Hydrodynamical Inst. (Moscow), 1936.
11. Wenzinger, Carl J., and Ames, Milton B.: Wind-Tunnel Investigation of Rectangular and Tapered N.A.C.A. 23012 Wings with Plain Ailerons and Full-Span Split Flaps. T.N. No. 661, N.A.C.A., 1938.



12. Wenzinger, Carl J., and Harris, Thomas A.: Wind-Tunnel Investigation of an N.A.C.A. 23012 Airfoil with Various Arrangements of Slotted Flaps. T.R. No. 664, N.A.C.A., 1939.
13. Harris, Thomas A.: The 7 by 10 Foot Wind Tunnel of the National Advisory Committee for Aeronautics. T.R. No. 412, N.A.C.A., 1931.
14. Cowley, W. L., and Lock, C. N. H.: Cushioning Effect of Aeroplanes Close to the Ground. R. & M. No. 754, British A.R.C., 1921.
15. Munk, Max M.: Elements of the Wing Section Theory and of the Wing Theory. T.R. No. 191, N.A.C.A., 1924.
16. Silverstein, Abe, and White, James A.: Wind-Tunnel Interference with Particular Reference to Off-Center Positions of the Wing and to the Downwash at the Tail. T.R. No. 547, N.A.C.A., 1935.
17. Theodorsen, Theodore: Interference on an Airfoil of Finite Span in an Open Rectangular Wind Tunnel. T.R. No. 461, N.A.C.A., 1933.

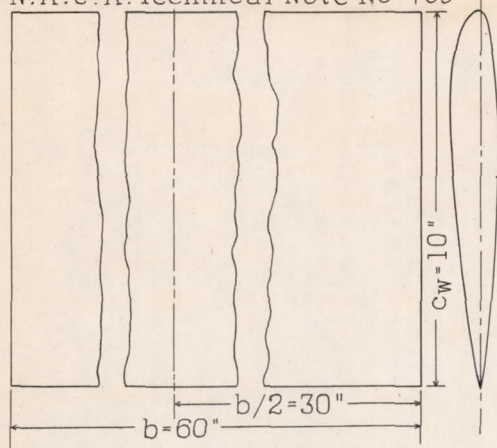

(a) Plain rectangular wing.

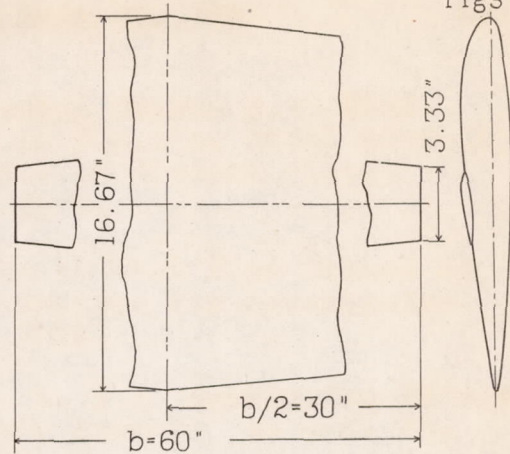

(a) Plain tapered wing.

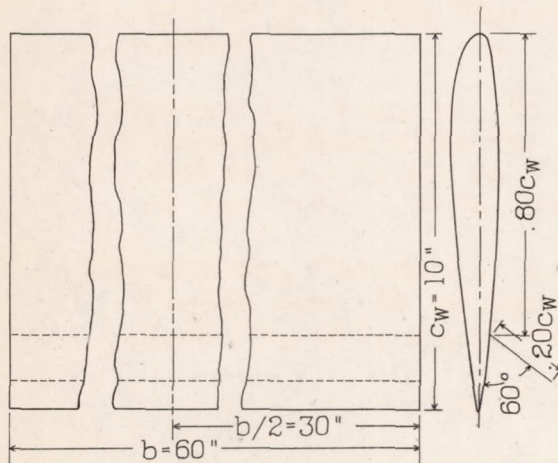

(b) Rectangular wing with  $0.20c_w$  split flap.

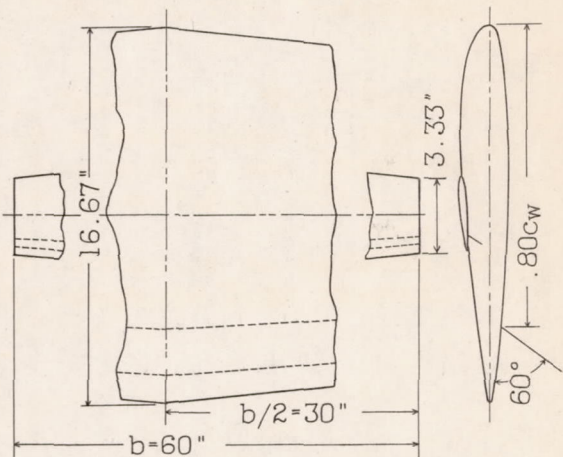

(b) Tapered wing with  $0.20c_w$  split flap.

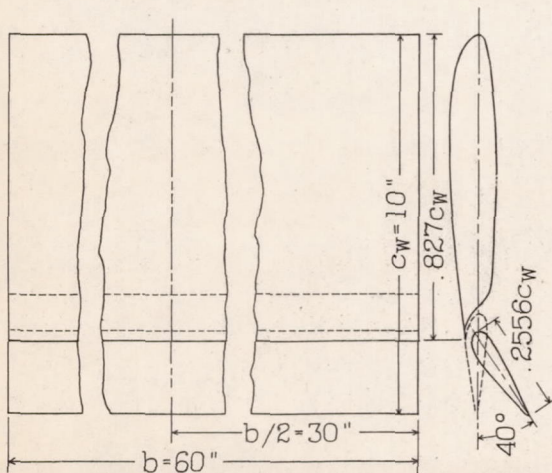

(c) Rectangular wing with  $0.2556c_w$  slotted flap.

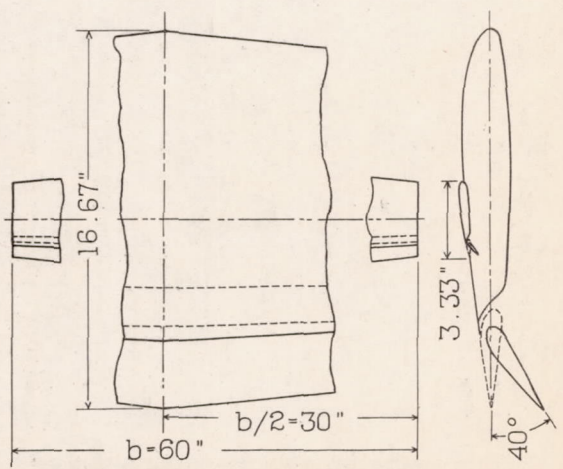

(c) Tapered wing with  $0.2556c_w$  slotted flap.

Figure 1. - N.A.C.A. 23012 rectangular wing models.

Figure 2. - N.A.C.A. 23012 tapered wing models.



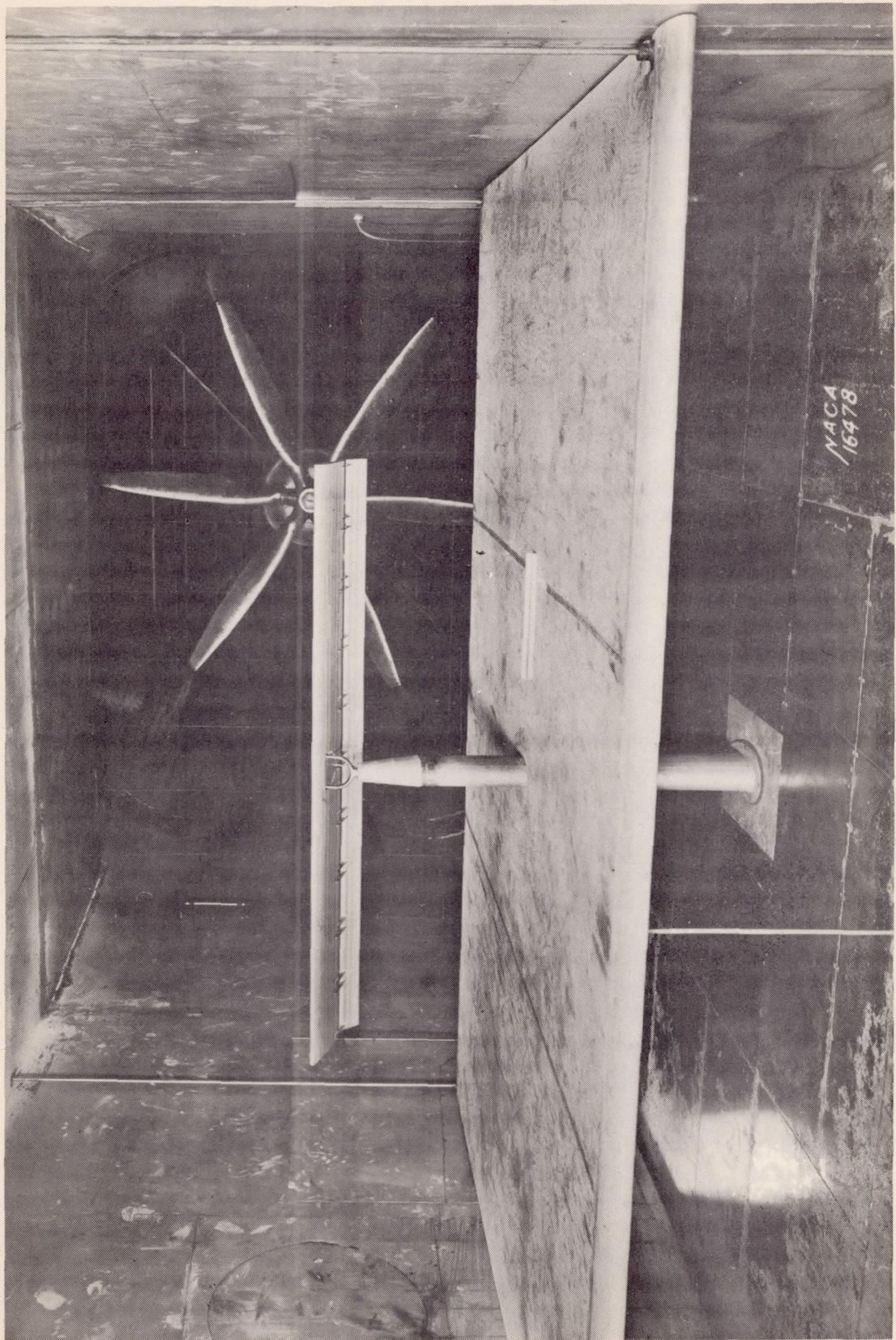

Figure 3.- Method of mounting ground plane in tunnel.



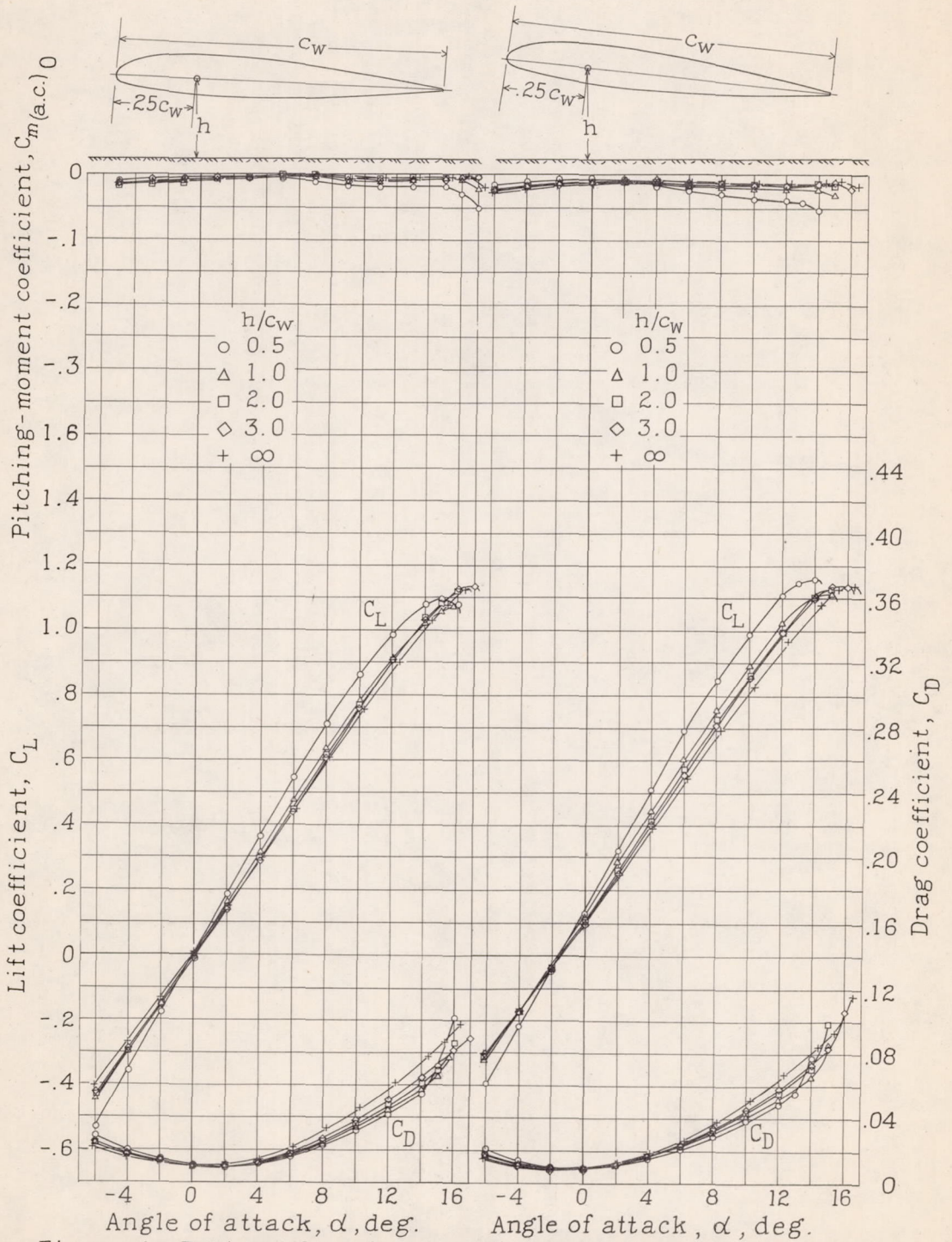

Figure 4.- Rectangular wing.

Figure 5.- Tapered wing;  
taper ratio, 5:1.

Effect of ground proximity on aerodynamic characteristics of N.A.C.A. 23012 wing.



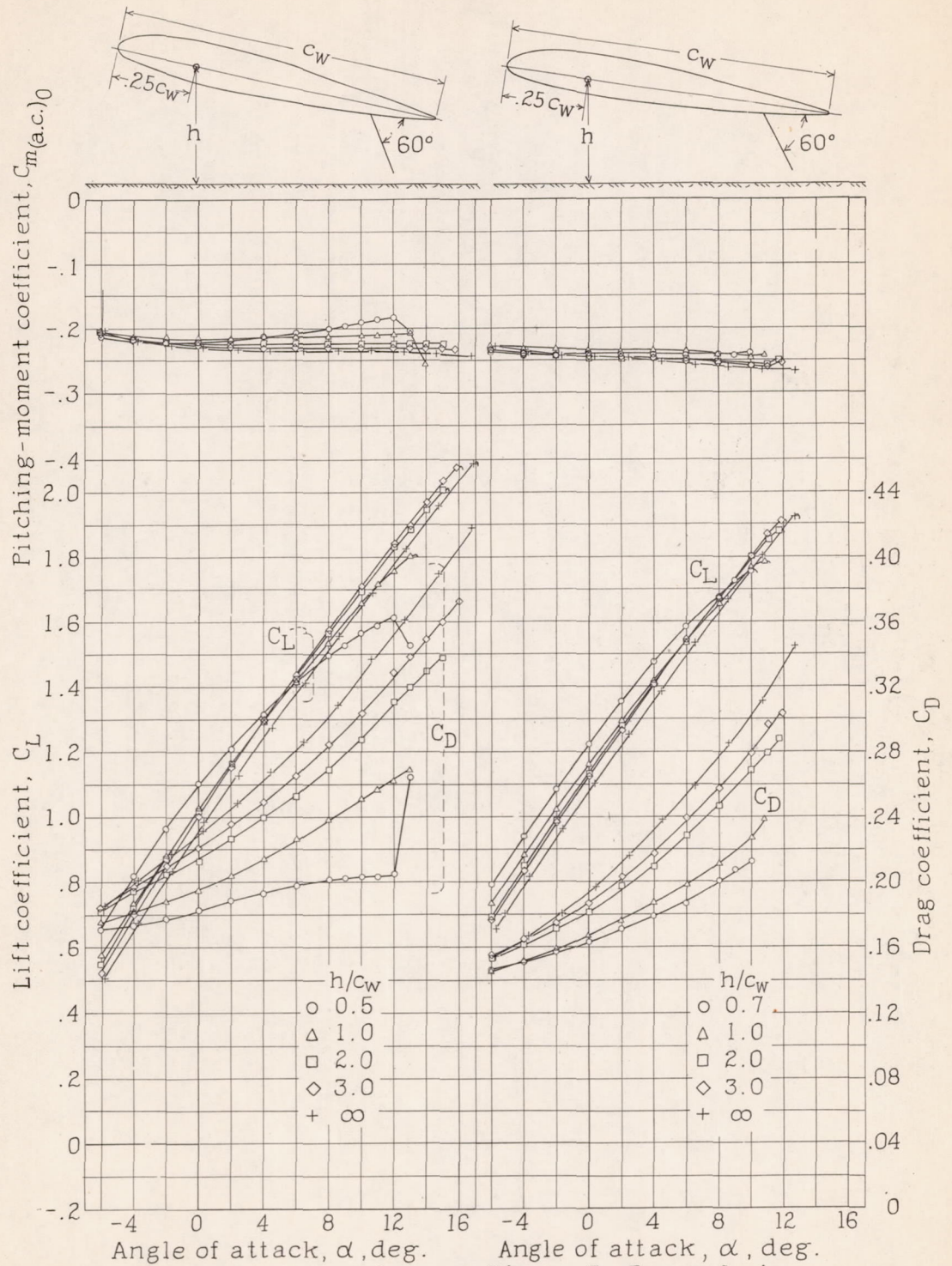

Figure 6. - Rectangular wing.

Figure 7. - Tapered wing;  
taper ratio, 5:1.

Effect of ground proximity on aerodynamic characteristics of N.A.C.A. 23012 wing with full-span  $0.20c_w$  split flap.

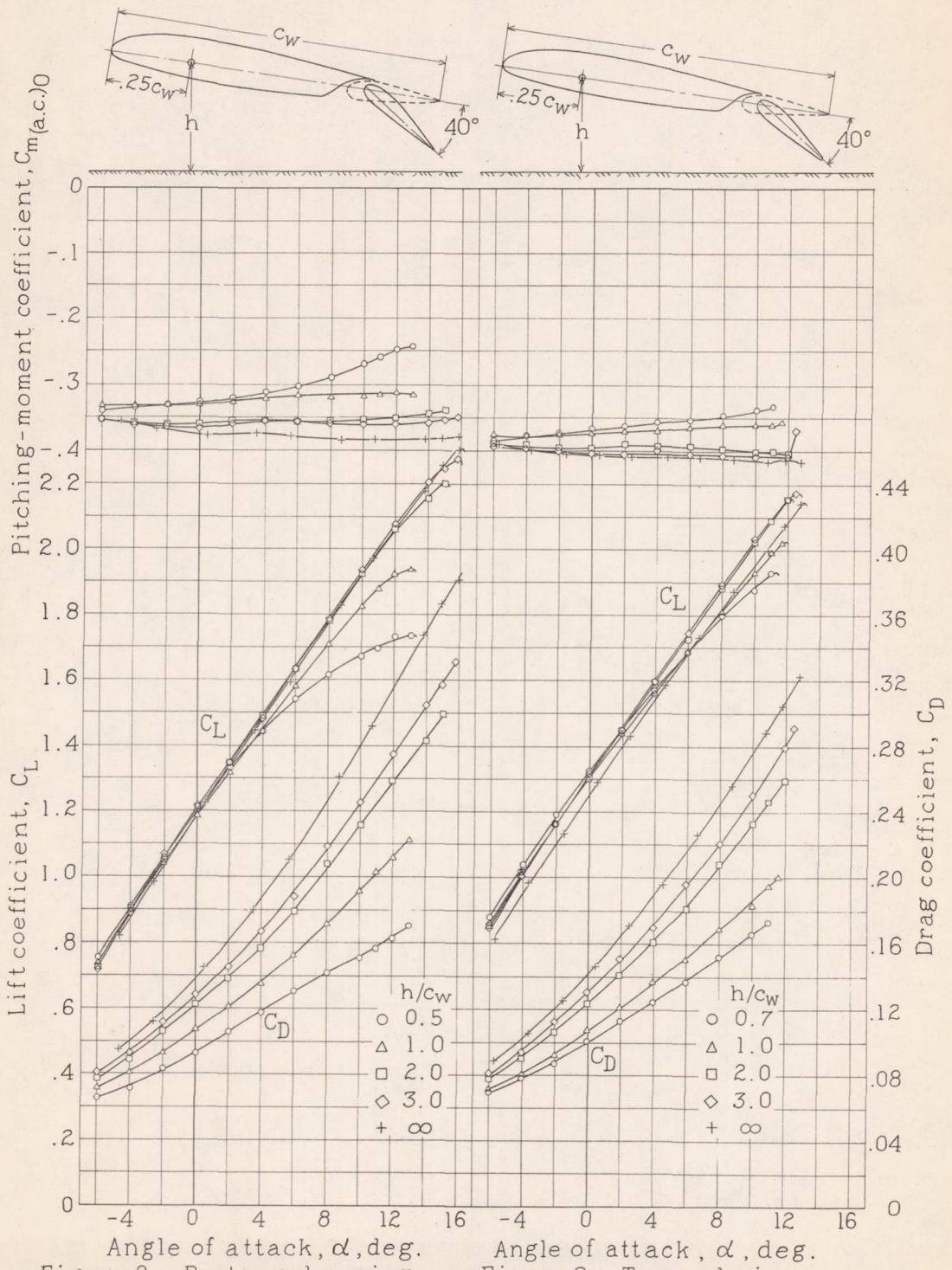

Figure 8. - Rectangular wing.

Figure 9. - Tapered wing; taper ratio, 5:1.

Effect of ground proximity on aerodynamic characteristics of N.A.C.A. 23012 wing with full-span  $0.2556c_w$  slotted flap.



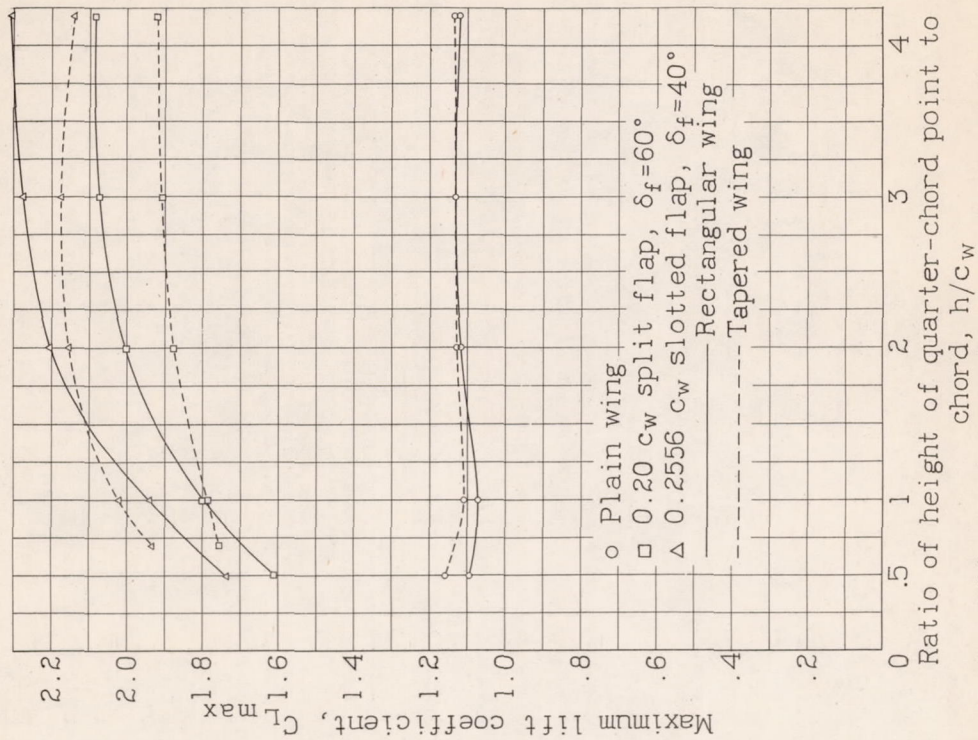

Figure 10.- Effect of ground proximity on maximum lift coefficients of N.A.C.A. 23012 wings.

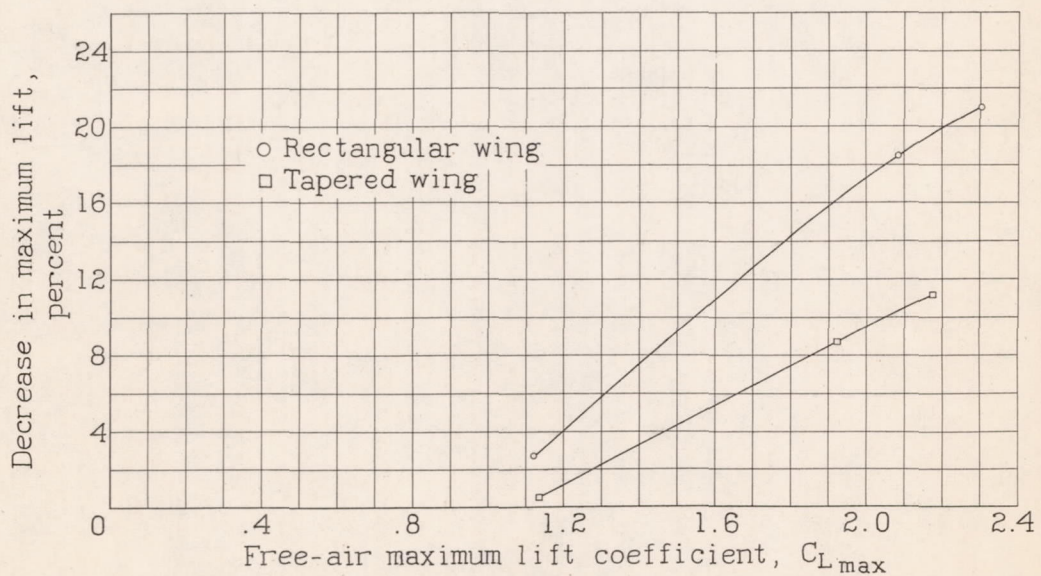
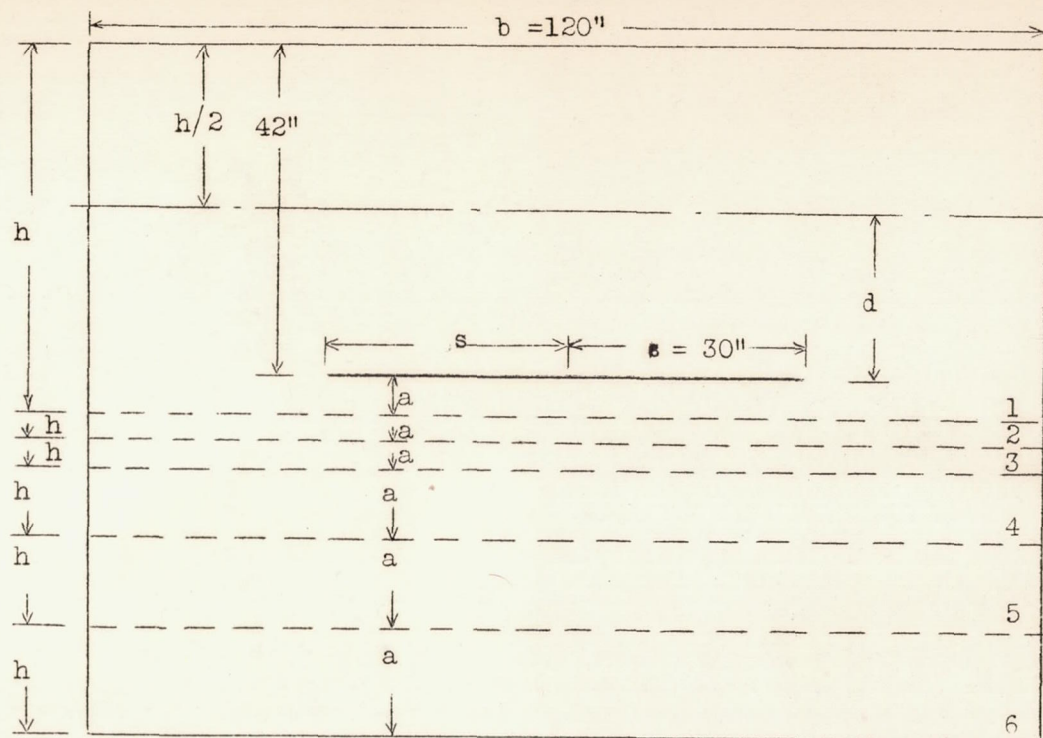

Figure 11.- Effect of free-air maximum lift coefficient on decrease in maximum lift due to ground effect at 0.7  $c_w$  below wing.





Figure 13.- Effective tunnel dimensions and wall-correction factors for various positions of ground board.



| Case | a(in.) | h(in.) | d(in.) | r=b/h | d/b   | $\sigma = \frac{1.65s}{b}$ | C = bh (sq.in.) | s/C   | $\delta_1$ | $\delta_2$ | $\delta_1 + \delta_2$ | $\delta_3$ | $\delta_N = \delta_1 + \delta_2 - \delta_3$ | $\delta_N s/C$ |
|------|--------|--------|--------|-------|-------|----------------------------|-----------------|-------|------------|------------|-----------------------|------------|---|----------------|
| 1    | 5      | 47     | 18.5   | 2.55  | 0.154 | 0.412                      | 5,640           | 0.106 | -0.075     | 0.376      | 0.301                 | 0.298      | 0.003                                       | 0.00032        |
| 2    | 7      | 49     | 17.5   | 2.45  | .146  | .412                       | 5,880           | .102  | -.072      | .326       | .254                  | .249       | .005  | .00051         |
| 3    | 10     | 52     | 16     | 2.31  | .133  | .412                       | 6,250           | .096  | -.068      | .275       | .207                  | .199       | .008  | .00077         |
| 4    | 20     | 62     | 11     | 1.94  | .092  | .412                       | 7,450           | .086  | -.054      | .192       | .138                  | .112       | .026  | .0022          |
| 5    | 30     | 72     | 6      | 1.67  | .050  | .412                       | 8,640           | .069  | -.042      | .155       | .113                  | .073       | .040  | .0027          |
| 6    | 42     | 84     | 0      | 1.43  | 0     | .412                       | 10,090          | .059  | -.028      | .140       | .112                  | .049       | .063  | .0037          |

Fig. 13