

1338
Library, R. M. A. L.

Gracey
1338
1338

TECHNICAL NOTES
NATIONAL ADVISORY COMMITTEE FOR AERONAUTICS

No. 632

IMPROVEMENT OF AILERON EFFECTIVENESS BY THE
PREVENTION OF AIR LEAKAGE THROUGH THE
HINGE GAP AS DETERMINED IN FLIGHT

By H. A. Soulé and W. Gracey
Langley Memorial Aeronautical Laboratory

Washington
January 1938



NATIONAL ADVISORY COMMITTEE FOR AERONAUTICS

TECHNICAL NOTE NO. 632

IMPROVEMENT OF AILERON EFFECTIVENESS BY THE
PREVENTION OF AIR LEAKAGE THROUGH THE
HINGE GAP AS DETERMINED IN FLIGHT

By H. A. Soulé and W. Gracey

SUMMARY

A flight investigation was made of the increase in effectiveness of ailerons that can be obtained by preventing flow of air through the wing at the hinges and of the possibility of reducing the aileron operating force by replacing ailerons having normal open hinge gaps with narrower but equally effective ailerons having sealed hinge gaps. Tests were made with a Fairchild 22 airplane with two sizes of plain unbalanced ailerons, one set having a chord equal to 0.18c and the other a chord equal to 0.09c.

The results of the investigation show that improvement in the lateral-control effectiveness is obtained by completely preventing the flow of air through the wing at the hinge axis of conventional ailerons. The magnitude of the improvement depends on the aileron chord. For the 0.18c ailerons the gain in aileron effectiveness due to sealing the gap at the hinge axis was of the order of one-fifth and for the 0.09c ailerons the gain was about one-third. The importance of sealing the gap was demonstrated by the fact that the 0.09c ailerons with a slight increase in deflection range were made as effective as the 0.18c ailerons with an unsealed gap but required only about one-third as large an operating force.

INTRODUCTION

It has been appreciated for a considerable time that, at least for wind-tunnel models, a gap in the wing contour at the hinge axis of the plain unbalanced aileron causes some decrease in aileron effectiveness. A recent study of the lateral-control problem (reference 1) has shown that

the loss of rolling moment due to a clearance between the wing and aileron as small as is practicable for wind-tunnel models is almost as serious as a wide gap. The loss of rolling moment per unit deflection increases as the aileron chord decreases and, with an aileron chord equal to 10 percent of the wing chord, is of the order of one-third the rolling moment obtainable with the gap at the aileron-hinge axis sealed. The results of the study indicated that, on the basis of the rolling moment obtained per unit operating force, a plain aileron of narrow chord with gap sealed was comparable with the best types of balanced and slotted ailerons. The reason for this condition is that, when balances are used, the reduction in hinge moment for a given aileron deflection is offset to a large extent by the loss in effectiveness per unit deflection so that a greater deflection is required. It was suggested that, if an improvement of the same order of magnitude were found in flight, it would be advantageous to replace plain ailerons having unsealed hinges with narrow-chord ailerons having sealed hinges.

The present flight tests were undertaken to determine whether the losses due to the gap between the aileron and the main portion of the wing for a typical case, where the clearances are proportionally smaller than they are for the wind-tunnel models, were as great as was indicated in the model tests. In addition, the possibility of utilizing the beneficial effects of sealing the aileron gap to reduce the operating force for a given effectiveness was investigated.

The investigation was made with one of the Committee's Fairchild 22 airplanes. Tests were made of the standard ailerons for this airplane and with ailerons of approximately one-half the chord of the standard ailerons. In both cases the tests were made with the gap sealed and unsealed, the sealing being accomplished by fastening a strip of fabric between the main portion of the wing and the leading edge of the aileron. The effectiveness of the ailerons was measured and an indication of the control forces was obtained by pilots' observations.

APPARATUS AND METHOD

The Fairchild 22 airplane used in the investigation is a small, externally braced, parasol monoplane (fig. 1).

For the investigation it was equipped with a wing of N.A.C.A. 2R₁12 airfoil section. This wing, which differed from the standard wing for the airplane only in section, was rectangular in plan form with semicircular tips. The span was 32 feet 10 inches, the chord 5 feet 6 inches, and the area 171 square feet.

The plain ailerons with which the wing was initially provided are shown in figures 1 and 2. The aileron chord was 0.18c and the span $0.82 b/2$. Figure 2 shows the type of gap at the aileron hinge and the manner in which it was sealed with fabric for the investigation. The ailerons were differentially operated through a total angular range of 25.7° . The variation of the aileron positions with control-stick position is given in figure 3.

For the second phase of the investigation, these ailerons were replaced by the 0.09c ailerons shown in figure 4. The span and the location of the ailerons on the wing trailing edge were the same as for the original ailerons. Approximately the same differential deflections were employed (fig. 5). For reasons that will be explained later, the deflection range of the narrower ailerons after the completion of preliminary tests was increased to 31.2° .

Similar tests were made with each set of ailerons and with the aileron-hinge gaps both open and sealed. They consisted of the measurement of the angular motion of the airplane in rolling and yawing following an abrupt aileron displacement. Two series of test runs were made. The first series was made to determine the variation of aileron effectiveness with deflection at two speeds, one representative of high-speed and the other of low-speed flight. The second series of runs was made to determine the maximum effectiveness of the ailerons at various speeds throughout the speed range.

The instruments used for the measurements were two angular-velocity recorders, one to record the rolling motion and the other the yawing motion; a control-position recorder to record the aileron deflection; and a device to time and synchronize the records. An attempt was made to measure the forces required to operate the ailerons but it was abandoned because, with the small operating forces experienced, the weight of the instrument introduced relatively large errors.

There are several bases upon which the relative roll-

ing effectiveness of the ailerons for the four test conditions might be judged, as, for example, the angle of bank attained in 1 second or the rolling-moment coefficient. All such possible bases of comparison are, of course, related and should show the same general trends, although greater variations may be found for one basis than for another. In order to obtain a more complete indication of the effect of sealing the aileron-hinge gap than would be possible from any one criterion, the maximum rolling velocities, the maximum rolling accelerations, the angles of bank attained in 1 second, and the rolling-moment coefficients were determined for each test condition. The maximum rolling velocities were obtained directly from the angular-velocity records. The maximum rolling accelerations and the angle of bank attained in 1 second were determined by differentiation and integration of these records, respectively. The rolling-moment coefficients were computed from the records, using the method described in reference 2. No attempt was made at evaluating the yawing records, which were used only to show the direction of the initial yawing motion. Pilots' observations were used as a measure of the relative magnitude of the forces required to operate the ailerons.

RESULTS AND DISCUSSION

A comparison of the results obtained with the different arrangements tested is shown graphically in figures 6 to 9. Figure 6 shows the maximum angular velocities in roll; figure 7, the maximum angular accelerations in roll; figure 8, the displacement in roll in 1 second; and figure 9, the rolling-moment coefficients. In each figure the results for the four arrangements tested are presented.

It will be noted that angular velocities and angular accelerations were not affected correspondingly proportionate amounts when the aileron gaps were sealed. Conclusions concerning the improvement due to sealing the gap therefore depend to some extent on the basis of comparison. In general, for the 0.18c ailerons, the improvement due to sealing the gap appears to be an increase of the order of one-fifth of the effectiveness of the unsealed aileron. On the basis of wind-tunnel tests of a wing alone, it was expected that the improvement would be of the order of two-fifths. The yawing characteristics of the ailerons appeared to be unaffected by the sealing of the hinge gap.

With the O.09c ailerons, the improvement in aileron effectiveness due to sealing the hinge gap was at least one-third. Here again the improvement was approximately one-half as great as was indicated by the tunnel tests. The hinge gap with the narrow-chord ailerons was shaped in a manner similar to that of the original O.18c ailerons but, for practical reasons, no attempt was made to hold the same relative clearances. The gap therefore was somewhat larger in proportion to the aileron chord than it was with the O.18c ailerons.

These results are believed to be representative of the improvement that may be expected in ordinary installations of plain ailerons. What the result would have been had the aileron hinge gaps been larger or smaller is not shown, but the wind-tunnel results seem to indicate that any gap is undesirable. Although the improvement obtained was only about half of that expected on the basis of the tunnel results reported in reference 1, it is still sufficiently large to be well worth while, particularly with the narrow-chord ailerons.

Before the influence of the narrow-chord ailerons on the aileron operating forces is discussed, it seems advisable to review the problem briefly in order to indicate more clearly how the reduction of operating force arises. First of all, it is assumed that the motion of the pilot's hand is limited so that any change in the range of deflections must be achieved by varying the linkage ratios and, hence, by changing the mechanical advantage of the control system. Thus, any increase in deflection range with a given size of aileron tends to increase the operating force because of the reduced mechanical advantage of the system as well as because of the increase of hinge moment due to the greater deflection. The next principle to consider is that the variation of the rolling moment obtainable with a given aileron deflection varies by less than the first power of the chord. Since improvement can be obtained by sealing the aileron hinge gap, it follows that with a decrease in chord the necessity for increasing the deflection range may be offset by sealing the hinge gap. Then, it may be possible to obtain the same effectiveness with the narrow aileron without any increase in the range of deflection. The hinge moment varies approximately as the square of the chord so that a very marked reduction in aileron operating force would be expected.

An analysis made for the present investigation on the

basis of the data given in reference 1, and in accordance with the foregoing principles, indicated that, with no change in the deflection range, the 0.09c ailerons with sealed hinge gap would be as effective as the original 0.18c ailerons with hinge gap open. Thus, it was expected that the required operating force with the narrow-chord ailerons would be approximately one-fourth as great as that with the original ailerons. The results of preliminary tests, however, showed that the gain due to sealing the hinge gap was somewhat less than was anticipated, so that it was necessary to increase the deflection range of the narrow-chord ailerons by an appreciable amount in order to obtain the same effectiveness as that of the original installation. For the rest of the tests, therefore, the maximum deflection range of the narrow-chord ailerons was increased from 25.7° to 31.2° in order to make the maximum angular velocities obtained equal to those of the original aileron installation. The maximum rolling velocities obtained with the initial and final deflections are shown in figure 10. Pilots' observations of the stick forces indicated that, with the final arrangement, the operating forces were only about one-third of those for the original aileron.

As an independent indication of the importance of sealing the hinge gap of the 0.09c ailerons, it is interesting to note that the pilots reported a very marked deficiency of the lateral control when the hinge gaps were unsealed. The pilots' impression, without reference to the actual measured results, was that the effectiveness of the narrow ailerons with the hinge gap sealed was equal to that of the original installation; whereas, with the hinge gap unsealed, there was a marked deficiency in lateral control. In fact, with the hinge gaps unsealed, the aileron power was not sufficient to bank the airplane to more than 60° .

CONCLUSIONS

1. Sealing the aileron-hinge gap of a conventional unbalanced aileron increased the aileron effectiveness about one-fifth for an aileron of 0.18c and about one-third for an aileron of 0.09c.
2. The 0.09c ailerons with sealed hinge gaps and a deflection range of 31.2° were as effective in producing angular velocity in roll as were the original 0.18c ailer-

ons with open hinge gaps with a deflection range of 25.7° ; the operating forces with the narrow ailerons were about one-third of those with the original ailerons.

Langley Memorial Aeronautical Laboratory,
National Advisory Committee for Aeronautics,
Langley Field, Va., December 22, 1937.

REFERENCES

1. Weick, Fred E., and Jones, Robert T.: Résumé and Analysis of N.A.C.A. Lateral Control Research. T.R. No. 605, N.A.C.A., 1937.
2. Soulé, H. A., and McAvoy, W. H.: Flight Investigation of Lateral Control Devices for Use with Full-Span Flaps. T.R. No. 517, N.A.C.A., 1935.

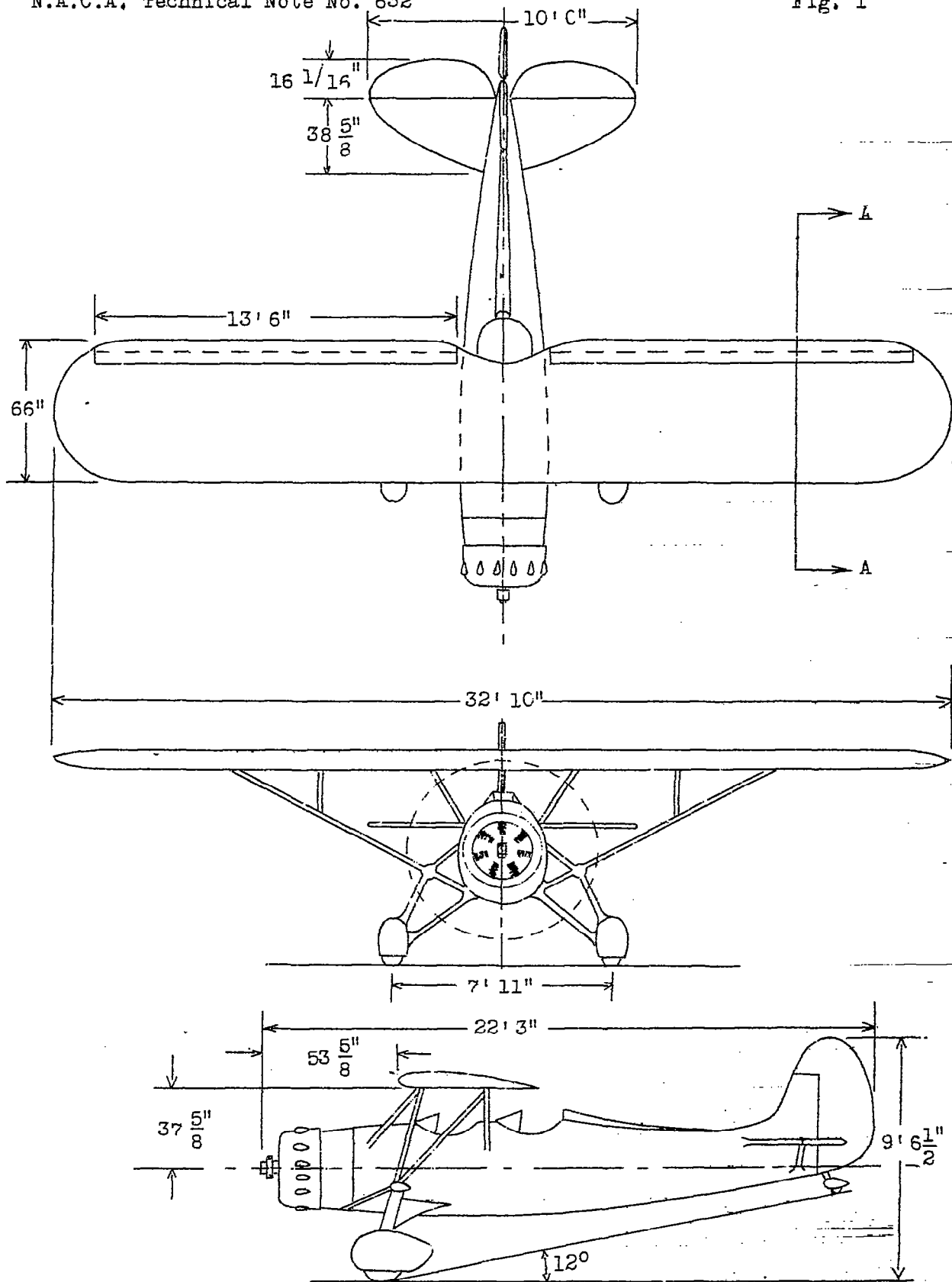
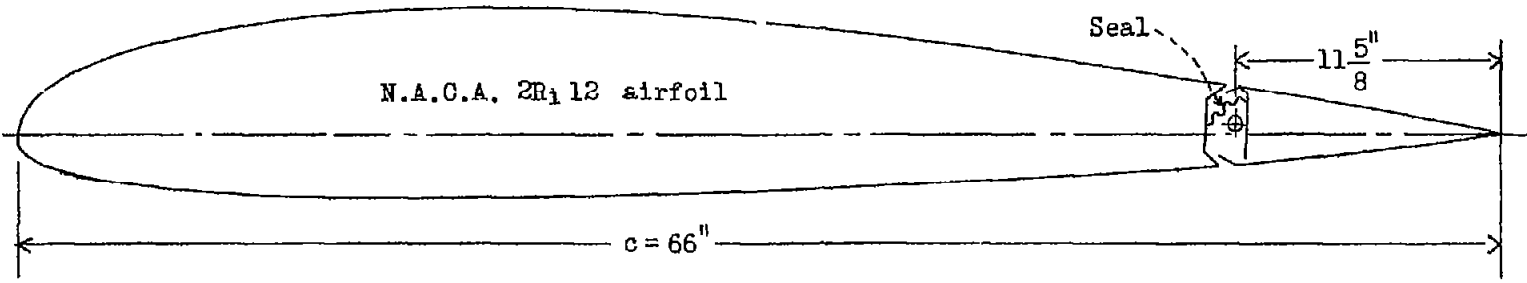
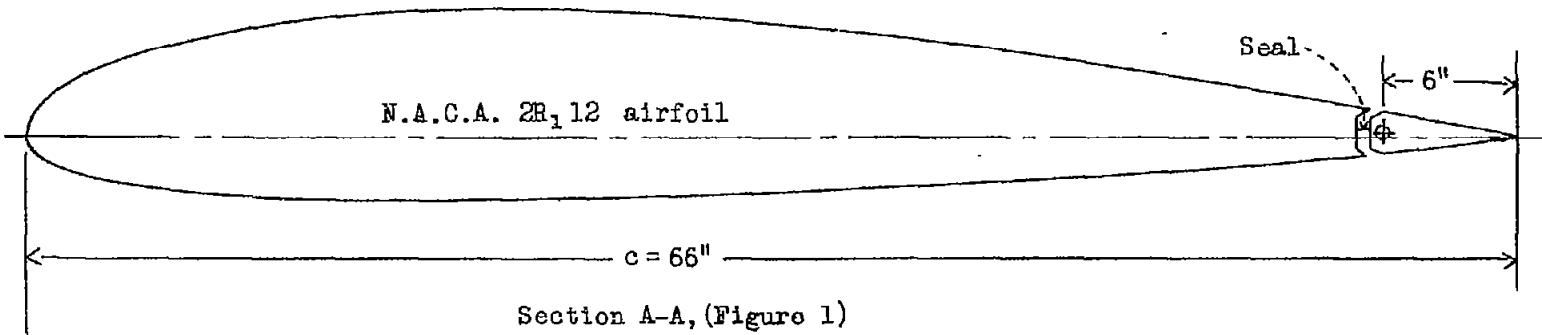

Figure 1.- Three-view drawing of the Fairchild 22 airplane.



Section A-A, (Figure 1)

Figure 2.- Section of wing with 0.18c aileron.



Section A-A, (Figure 1)

Figure 4.- Section of wing with 0.09c aileron.

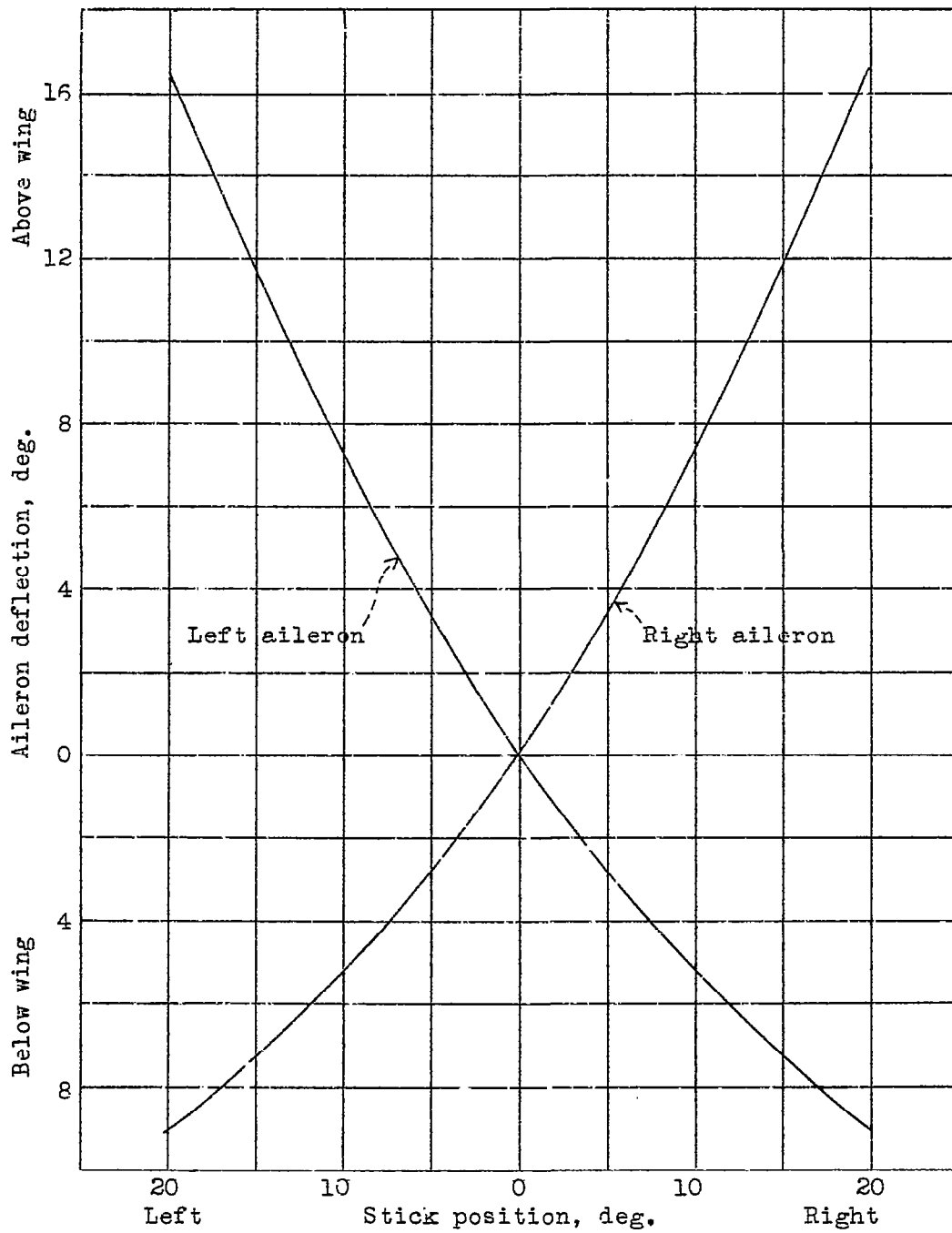

Figure 3.- Variation of aileron position with control-stick position with 0.18c ailerons.

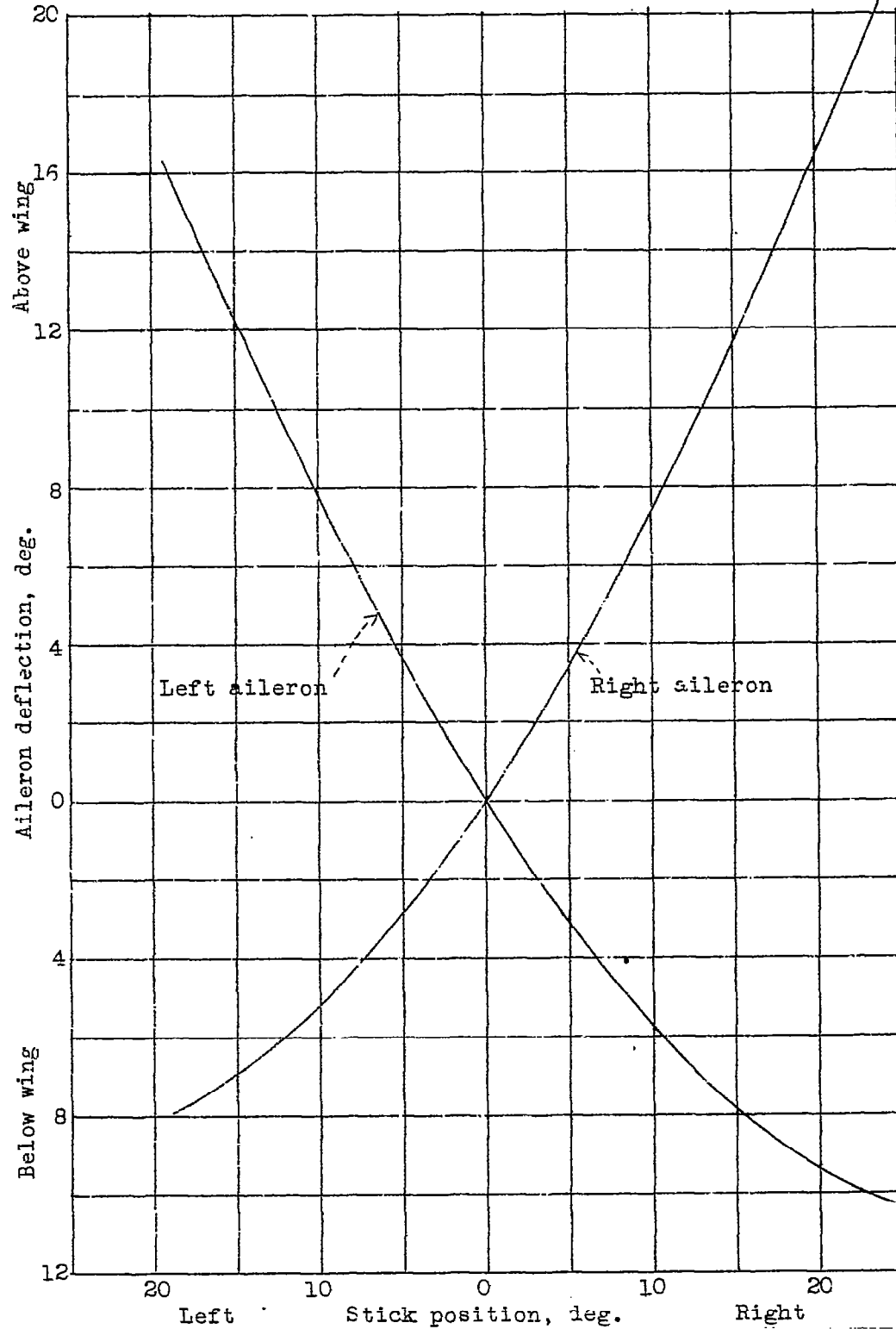

Figure 5.- Variation of aileron position with control-stick position with 0.09c ailerons.

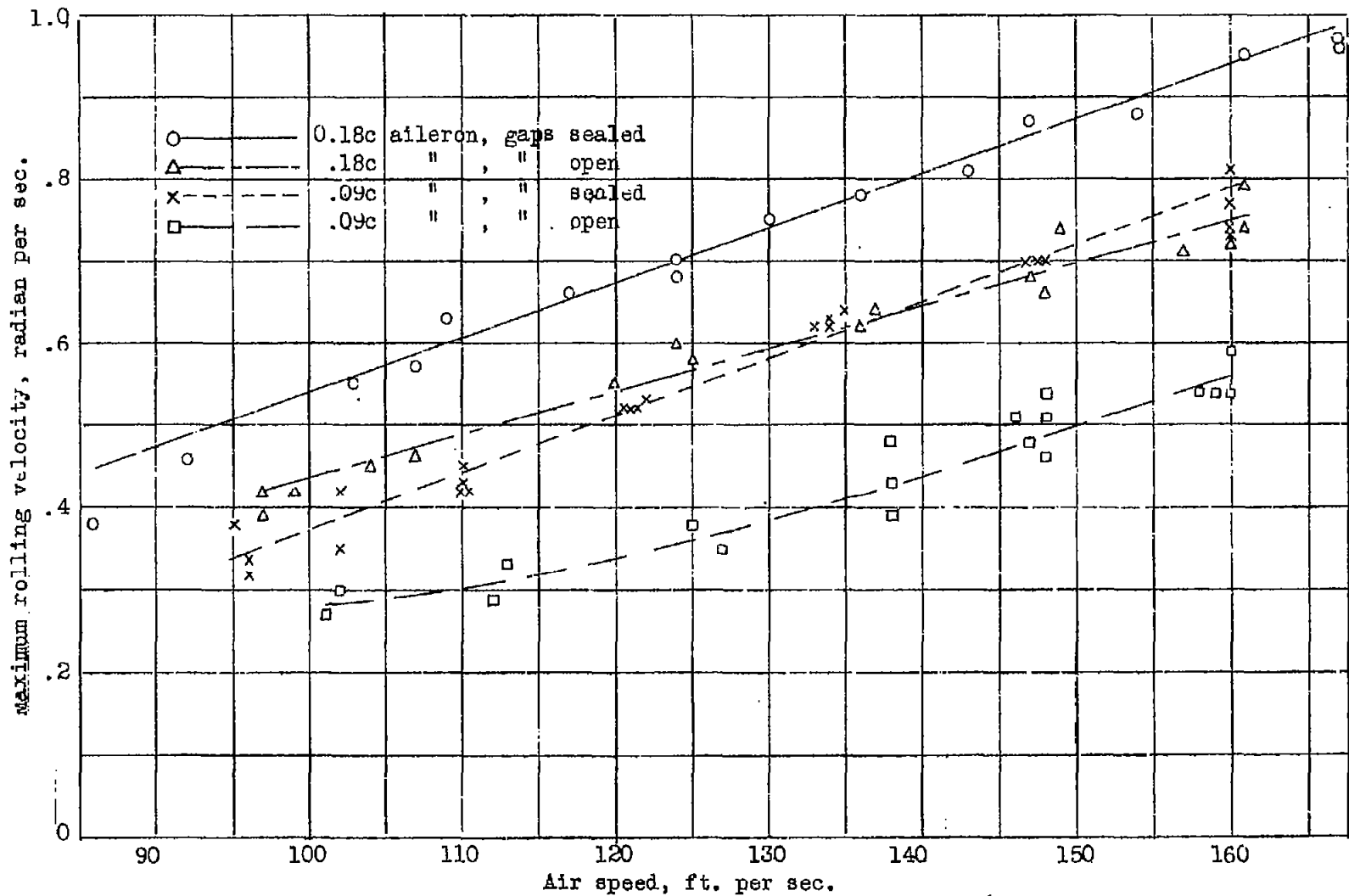

Figure 6.- Maximum rolling velocities obtained with 0.18c and 0.09c ailerons.

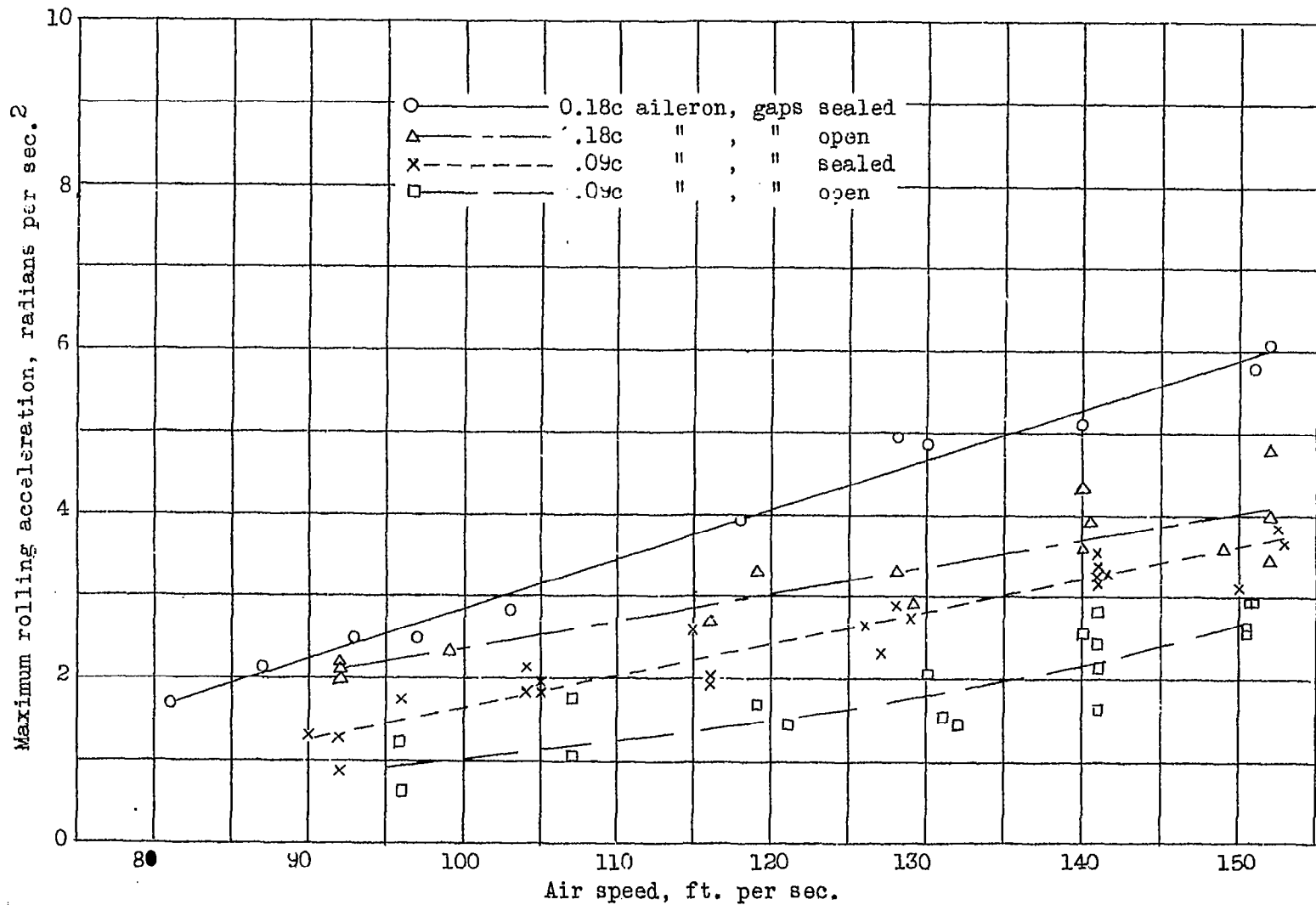

Figure 7.- Maximum rolling accelerations obtained with 0.18c and 0.09c ailerons.

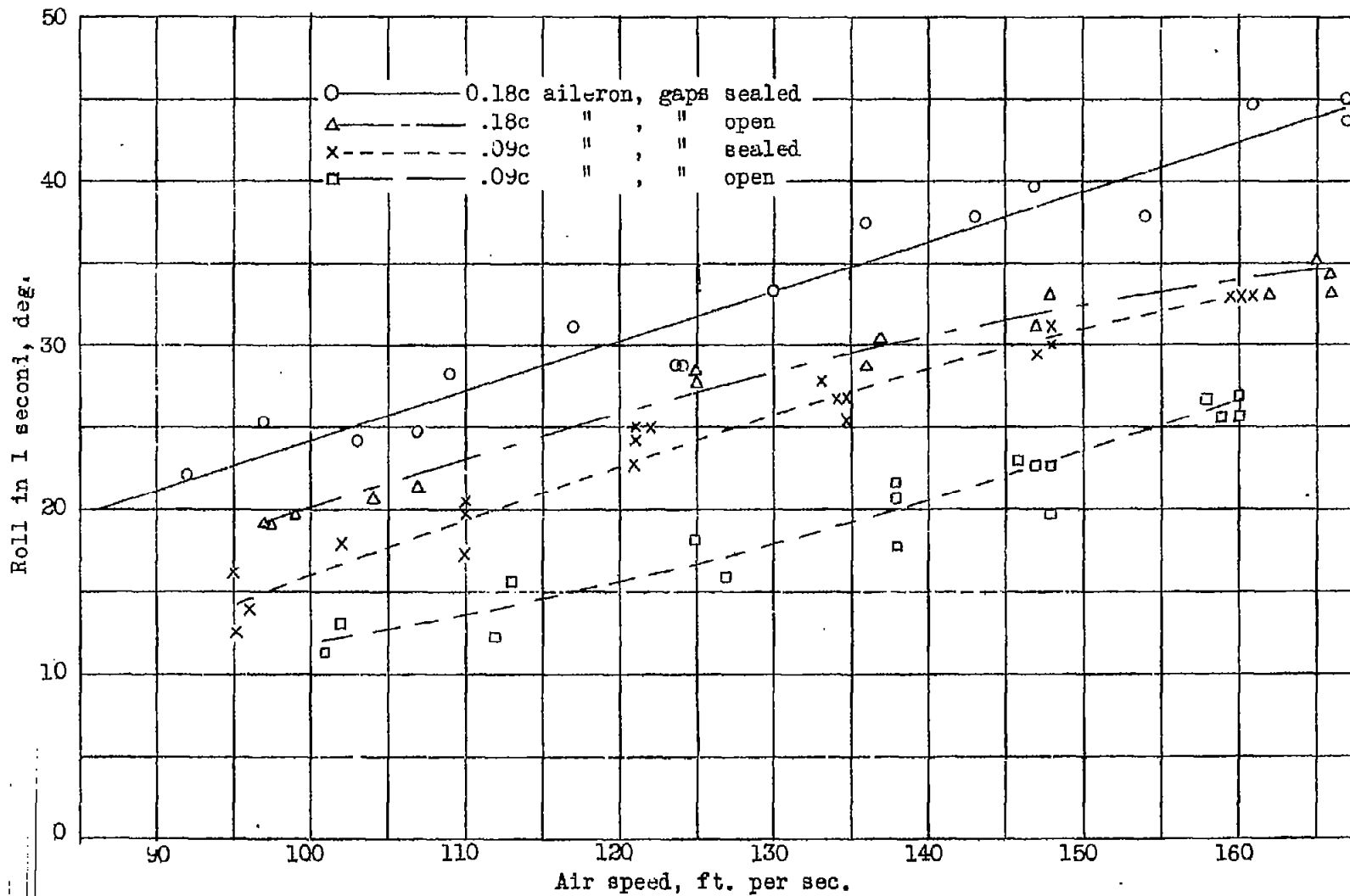

Figure 8.- Angular displacements in roll in 1 second obtained with 0.18c and 0.09c ailerons.

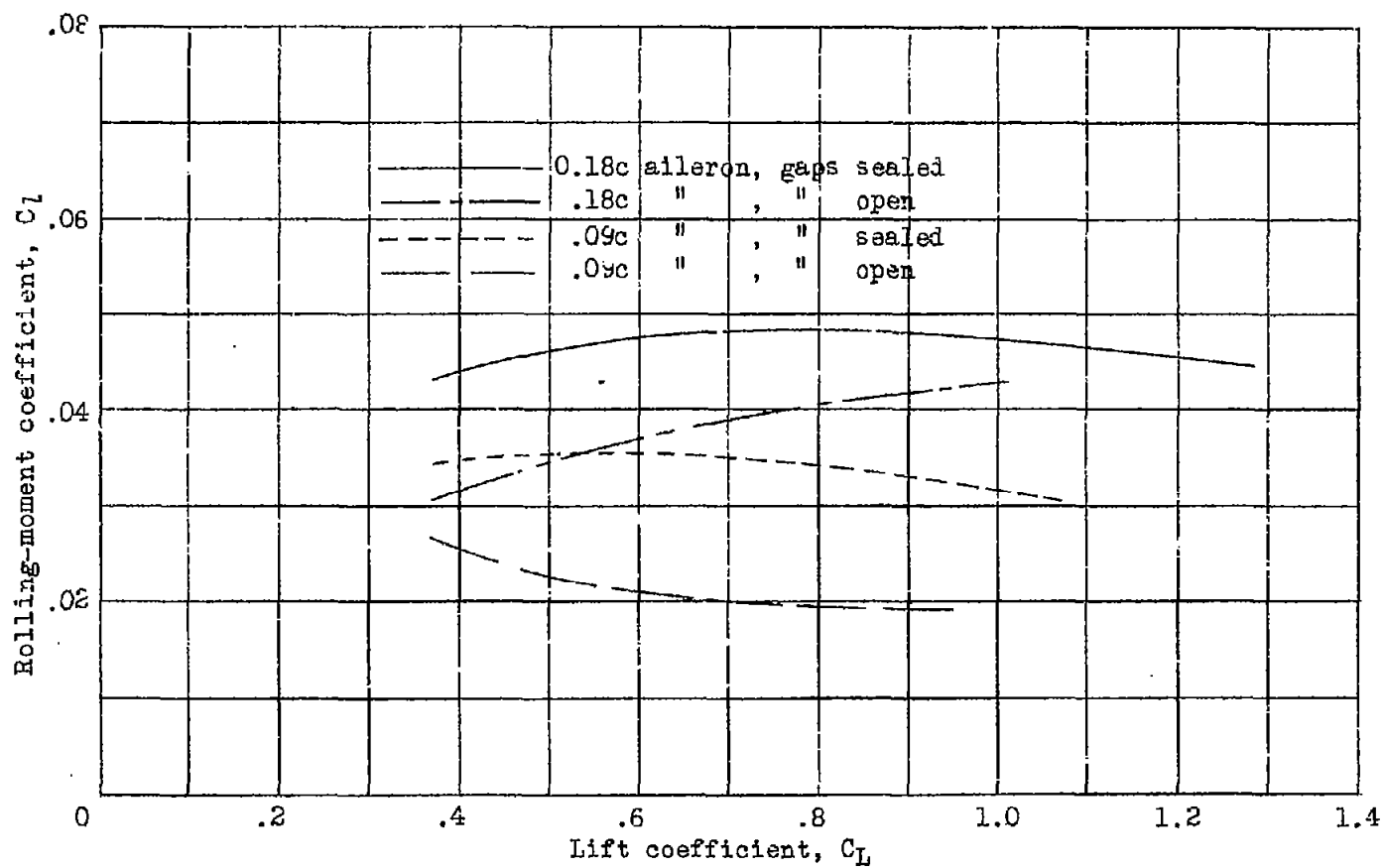

Figure 9.- Variation of rolling-moment coefficients with lift coefficients for 0.18c and 0.09c ailerons.

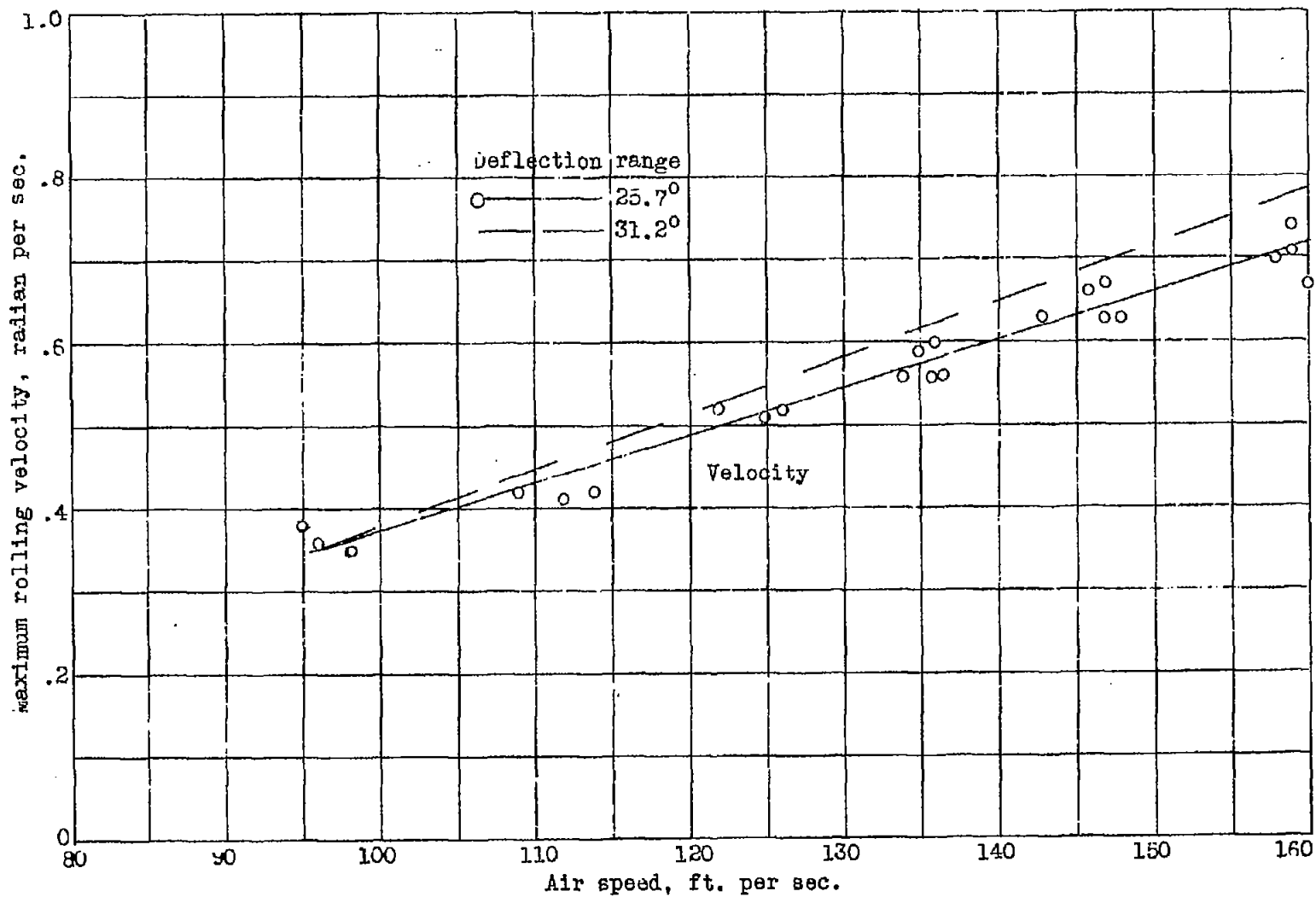

Figure 10.-- Maximum rolling velocities obtained with 0.09c ailerons with deflection ranges of 25° and 31°.