

Y3.N215:6/688  
National Advisory Committee

NG 88

GOVT. DOC.

for Aeronautics

MAILED

FEB 27 1939

To Library, Hartford Public

TECHNICAL NOTES

NATIONAL ADVISORY COMMITTEE FOR AERONAUTICS

-----  
No. 688  
-----

COMPARATIVE PERFORMANCE OF ENGINES USING A CARBURETOR,  
MANIFOLD INJECTION, AND CYLINDER INJECTION

By Oscar W. Schey and J. Denny Clark  
Langley Memorial Aeronautical Laboratory

-----

Washington  
February 1939

BUSINESS, SCIENCE  
& TECHNOLOGY DEPT.

NATIONAL ADVISORY COMMITTEE FOR AERONAUTICS

TECHNICAL NOTE NO. 688

COMPARATIVE PERFORMANCE OF ENGINES USING A CARBURETOR,  
MANIFOLD INJECTION, AND CYLINDER INJECTION

By Oscar W. Schey and J. Denny Clark

SUMMARY

The comparative performance was determined of engines using three methods of mixing the fuel and the air: the use of a carburetor, manifold injection, and cylinder injection. The tests were made of a single-cylinder engine with a Wright 1820-G air-cooled cylinder.

Each method of mixing the fuel and the air was investigated over a range of fuel-air ratios from 0.10 to the limit of stable operation and at engine speeds of 1,500 and 1,900 r.p.m. The comparative performance with a fuel-air ratio of 0.08 was investigated for speeds from 1,300 to 1,900 r.p.m.

The results show that the power obtained with each method closely followed the volumetric efficiency; the power was therefore the highest with cylinder injection because this method had less manifold restriction. The values of minimum specific fuel consumption obtained with each method of mixing of fuel and air were the same. For the same engine and cooling conditions, the cylinder temperatures are the same regardless of the method used for mixing the fuel and the air.

INTRODUCTION

Fuels for spark-ignition engines have been successfully mixed with the air by three methods: the use of the carburetor, the use of a fuel-injection system injecting into the manifold or into the impeller casing, and the use of a fuel-injection system injecting directly into the cylinder. The carburetor has been extensively used in service but fuel-injection systems have been used only on experimental engines.

Although there is an abundance of performance data available for each of these methods of mixing the fuel and the air, it would be difficult to establish conclusively the comparative performance from these data because of differences in test conditions and equipment. Several years ago the N.A.C.A. conducted an investigation on a single-cylinder engine using a carburetor and a fuel system injecting directly into the cylinder; the results showed that about 8 pounds per square inch higher brake mean effective pressure was obtained with the fuel-injection system than with the carburetor (reference 1). Later tests on another engine of different bore and stroke but using the same carburetor and fuel-injection system resulted in a difference of only 3 pounds per square inch brake mean effective pressure in favor of the fuel-injection system (reference 2). In the second series of tests, the specific fuel consumption was less with the carburetor than with the fuel-injection system.

As the data available had been obtained for such a large variation in operating conditions and for different engines of the single-cylinder and the multicylinder types, the fairness of a comparison of these data would always be subject to question. Therefore, in order to obtain more conclusive data on the comparative performance of the three methods of mixing the fuel and the air, the Committee has conducted further tests using each method on the same single-cylinder air-cooled engine, equipped with a cylinder of the latest design which had proved very satisfactory in service. The necessary observations were made to establish the comparative power output, the fuel consumption, and the cylinder temperatures.

#### EQUIPMENT

Test Engine.— A photograph of the single-cylinder engine with some of the test equipment is shown in figure 1. A diagrammatic sketch showing the arrangement of the equipment is given in figure 2. The air-cooled four-stroke-cycle spark-ignition engine used in this investigation had a 6-1/8 inch bore, a 7-inch stroke, and a 7.4 compression ratio. (See reference 3.) A Wright 1820-G cylinder was used, modified as shown in figure 3 by inserting a bushing in the head for the injection valve.

In the carburetor tests, a Stromberg NAL-5 carburetor was used, which was modified by installing needle valves in the main jets to regulate the fuel flow. When either manifold or cylinder fuel injection was used, the carburetor was replaced by a straight intake pipe containing a single butterfly valve for throttling the engine, in order to avoid as much as possible penalizing the fuel-injection performance with the pressure drop that occurs in the carburetor.

The manifold and the cylinder injection valves used are shown in figure 4(a) and figure 4(b), respectively. The manifold injection valve, developed by the Army Air Corps, had an opening pressure of 300 pounds per square inch and was centrally located in the intake pipe and about 7 inches from the intake valve with the fuel spray directed against the air stream as recommended by the Matériel Division (reference 4). The cylinder injection valve is an automatic spring-loaded type of N.A.C.A. design; it was set for a valve-opening pressure of 2,000 pounds per square inch. The nozzle used with this injection valve has a slit opening and was assembled to direct the fuel spray in a horizontal plane across the combustion chamber. (See fig. 4(b).)

For both the manifold and the cylinder fuel-injection tests, a Compur fuel-injection pump was driven from the engine crankshaft through a reduction gear that permitted the timing of the injection to be changed. The injection period of this pump varied from 55 to 100 crankshaft degrees depending upon the fuel quantity, the pump speed, and the pump discharge pressure.

The engine intake was connected through a series of surge tanks with thin rubber heads to a gasometer of 100-cubic-foot capacity of which 80 cubic feet were used for measuring the air consumed by the engine. When the carburetor was used, one of the surge tanks was placed 8 inches closer to the engine than when manifold or cylinder injection was used, as shown in figure 2.

The cooling-air system consisted of an orifice tank for measuring the quantity of cooling air supplied, a centrifugal blower for forcing the air past the cylinder, two 30-kilowatt electric air heaters, ducts for conveying the air, and a jacket enclosing the cylinder. The jacket had a wide entrance section giving a low air velocity over the front half of the cylinder; over the rear half, the jacket

fitted closely against the fins so that a high air velocity resulted. The exit opening was equal to 1.6 times the free area between the fins. The standard test-engine equipment was used for measuring torque, engine speed, and fuel consumption.

Instruments.— The cylinder temperatures were measured at the 34 points shown in figure 3, using iron-constantan thermocouples and a potentiometer. The thermocouples were peened into holes drilled in the aluminum head and spot-welded to the steel barrel. Two sets of four iron-constantan thermocouples, each set connected in series, were used to measure the temperature of the exit cooling air. Two sets of two chromel-constantan thermocouples, each set connected in series, were used to measure the temperature of the inlet cooling air.

The temperatures of the room, the thermocouple cold junction, the engine intake air, and the lubricating oil-out were measured with calibrated liquid-in-glass thermometers.

The pressures in the orifice tank and at the cylinder-jacket inlet were measured with water manometers.

A commercial mixture analyzer was used to obtain an indication of the mixture strength supplied to the engine and to facilitate the adjustment of the mixture. The fuel-air ratios were determined from the air measurements and the fuel weights.

## PRELIMINARY TESTS AND RESULTS

### Injection into the Cylinder

Before the final tests with fuel injected directly into the cylinder were made, many types of nozzles were tried to determine which gave the best power and economy. The best valve-opening pressure and location were also determined. In these preliminary tests, three fuel-injection pumps were tried. Although the results obtained in the preliminary tests to determine the best operating conditions are not strictly comparable, they are included because they contain useful information.

Selection of injection-valve location and nozzle for best performance.- In previous investigations with cylinder injection on four-valve engines, the best performance was obtained with the injection valve located between the two exhaust valves and with the fuel injected across the cylinder toward the incoming air. These investigations also showed that very good performance could be obtained with the valve centrally located in the top of the cylinder head. Only two injection-valve locations were tried on the two-valve cylinder used in these tests because previous experience indicated that, of the few desirable positions available, the two selected would probably be about the best for this cylinder. One of these locations was the rear spark-plug opening and the other was just above the steel cylinder barrel between the rear spark plug and the intake port, as shown in figure 3. The position shown in figure 3 gave the better performance of the two positions tried and was therefore used in all the tests made to determine the performance with fuel injection directly into the cylinder.

Several sizes of multiorifice and slit nozzles were tried and a slit nozzle giving a fan-shaped spray was chosen. With this nozzle and this valve location, the spray was directed horizontally across the combustion chamber. The results of the tests of the various nozzles and the two valve locations are shown in figure 5.

Selection of injection pump.- In the selection of the fuel-injection pump giving the best performance, the Eclipse, the Compur, and the Bosch pumps were tried. Tests of these pumps with the start of injection varied from top center on the suction stroke to 100 crankshaft degrees after bottom center showed that with the same start of injection, for all practical purposes, the power output of the engine was the same with each pump and the fuel consumption was slightly lower with the Bosch pump. (See fig. 6.) A start of injection as late as 60° after bottom center on the compression stroke showed only a small decrease in power and a small increase in fuel consumption compared with the best start of injection; this condition is believed to be due to the fact that, with a tangential inlet, an air flow conducive to a good mixing of the fuel and the air persists late in the compression stroke. The percentage of maximum power output obtained at a particular speed with a late start of injection for specific injection conditions may offer a means for determining the relative turbulence obtained with different combustion chambers.

The results of the bench tests to determine the length of the injection period and the rate of discharge for each of these three pumps are shown in figure 7. The pump setting, or the fuel quantity, was the same for the bench tests as was used in the engine tests of figure 6. From the results shown in figures 6 and 7, it is apparent that the length of injection period or the rate of discharge may be appreciably varied without any measurable effect on engine performance.

Selection of injection valve-opening pressure.-- Tests were made with valve-opening pressures of 1,000, 2,000, and 3,000 pounds per square inch. The power and the fuel consumption obtained for these valve-opening pressures are shown in figure 8. With early injection there is practically no difference in power or fuel consumption; but, with very late injection, better results were obtained with the higher injection pressures. With the start of injection 60 to 70 crankshaft degrees after top center on the suction stroke, the maximum power is the same regardless of the injection pressure and the specific fuel consumption is only 0.02 pound per brake horsepower-hour better with the highest injection pressure than with the medium or the low pressures. For the comparative tests, a valve-opening pressure of 2,000 pounds per square inch was used because excessive leakage past the pump plunger was obtained with 3,000 pounds per square inch valve-opening pressure.

#### Injection into the Manifold

Preliminary tests with manifold injection showed that the brake mean effective pressure was practically the same regardless of the start of injection. In the comparative tests, injection was started 60 crankshaft degrees after top center, as other tests conducted by the Army Air Corps Matériel Division showed that, with injection started at this point, there was little condensing of the fuel on the walls of the manifold. No attempt was made to determine whether better performance could be obtained with valve-opening pressures other than 200 pounds per square inch or with the injection valve in a different location.

#### Carburetor

No preliminary tests with the carburetor were considered necessary because in previous tests with the carbu-

retor on this engine (reference 3), high power and very low fuel consumption were obtained.

#### METHODS AND TESTS

The comparative performance with each of the three methods of mixing fuel with the air was determined at 1,500 and 1,900 r.p.m. over a range of fuel-air ratios from 0.10 to the limit of stable engine operation, and also over a range of engine speeds from 1,300 to 1,900 r.p.m. at a fuel-air ratio of 0.08. All tests were conducted with full open throttle.

The spark timing was adjusted for each test condition to give optimum engine performance. The weight of air supplied to the engine for cooling was kept constant for all tests.

The friction of the engine was determined by motoring it at the engine speeds used in the power runs. During the friction runs, the lubricating oil and the cooling air were heated to maintain oil-out and cylinder temperatures of 160° F., and 250° F., respectively. These temperatures are approximately the average existing during the power runs.

The brake-power readings were corrected to standard sea-level temperature and pressure at the engine intake on the assumption that the engine power varied directly as the pressure and inversely as the square root of the absolute temperature. The indicated power was obtained by adding the friction to the corrected brake readings.

Gasoline conforming to the Army specification 2-92, grade 100 was used throughout the tests. With this fuel there was no audible knock during any of the tests.

The various measurements made in this investigation may be considered accurate within the following limits:

Torque-scale readings . . . . .	±1 percent
Fuel consumption . . . . .	0 to -2-1/2 percent
Air consumption . . . . .	±1 percent



Cylinder temperatures . . . . .  $\pm 4^{\circ}$  F.

Inlet and outlet cooling-air  
temperatures . . . . .  $\pm 2^{\circ}$  F.

Pressure drop across cylinder  $\pm 1/10$  inch of water

## RESULTS AND DISCUSSION

Engine performance.— The comparative performances obtained with the three methods of mixing of the fuel and the air are shown in figures 9 and 10. Except at low speeds, the difference in mean effective pressure follows the volumetric efficiency very closely. The highest mean effective pressures are obtained with fuel injection into the cylinder because more air is inducted. With the fuel injected into the cylinder, the volumetric efficiency increases appreciably as the engine speed is increased compared with a decrease in volumetric efficiency at speeds over 1,600 r.p.m. when the carburetor is used. At 1,900 r.p.m., the volumetric efficiency with fuel injected into the cylinder is 92.5 percent compared with 86 percent with the carburetor.

That the volumetric efficiency should be lower with fuel injection into the manifold than with injection into the cylinder was unexpected. Furthermore, other tests at 1,500 r.p.m. when the carburetor was used showed no measurable difference in volumetric efficiency for conditions with or without the manifold nozzle in place. Tests by other investigators have shown that the volumetric efficiency with manifold injection is the same when the fuel spray is directed against or with the incoming air (reference 5). The lower volumetric efficiency with manifold injection is probably caused by an increased volume of charge created by vaporization of fuel in the manifold. With manifold injection, the temperature of the charge will be less owing to the vaporization of the fuel, and therefore more heat will be absorbed as the charge passes through the intake ports and the valves than with cylinder injection. The fact that the volumetric efficiency is slightly lower with injection into the manifold than with the carburetor is probably due to the difference in the manifolding rather than to the method of mixing the fuel and the air. It would be reasonable to expect that the volumetric efficiency with manifold injection should be

higher than with the carburetor because the restriction is less.

The increased charge that can be obtained with fuel injection into the cylinder is an important advantage and should be utilized to the maximum practical limit. Large manifolds can obviously be used but the size of the intake valves is limited by structural requirements and by the requirement of sufficient velocity through the port to create the turbulence necessary in the mixing of fuel and air and to assist the propagation of the flame. The velocity requirement would apply only to slow-speed engines or to sleeve-valve engines having very large intake ports or valve-opening areas, because the modern high-speed poppet-valve engines, even with very large intake valves, obtain sufficient velocity through the valves to give the necessary turbulence. When manifold injection or a carburetor is used, higher manifold velocities are necessary to mix the fuel and the air and to prevent separation and condensation; these methods must therefore offer some restriction to the free flow of the air. When fuel injection into the manifold is used, this restriction on a well-proportioned induction system is less than with a carburetor.

As shown in figure 10, the minimum specific fuel consumption for each method of mixing of the fuel and the air is the same. The engine equipped with a carburetor ran more smoothly on a leaner mixture at all speeds than when either of the other methods of mixing was used. The engine equipped with fuel injection into the manifold required the richest mixture for smooth running. The difference in mixture strength required for smooth operation with the carburetor and with fuel injection into the cylinder was less at low speeds than at high speeds.

Engine cooling.— Equations have been derived (reference 6) in which the average head and barrel temperatures of the cylinder are given as functions of the engine and the cooling variables. Such equations make possible the comparison of cooling data with widely different engine and cooling conditions. The equations may be written as follows:

$$\frac{T_h - T_a}{T_g - T_h} = K_1 \frac{I^{n'}}{(\Delta p p / \rho_o)^m} \quad (\text{head}) \quad (1)$$

$$\frac{T_b - T_a}{T_g - T_b} = K_2 \frac{I^{n'}}{(\Delta p \rho / \rho_0)^m} \quad (\text{barrel}) \quad (2)$$

where

- $T_h$  is the average cylinder-head temperature, °F.  
 $T_b$ , average cylinder-barrel temperature, °F.  
 $T_a$ , inlet temperature of the cooling air, °F.  
 $T_g$ , effective gas temperature, °F.  
 $I$ , indicated horsepower (observed brake + friction).  
 $\Delta p$ , pressure difference across cylinder, in. water.  
 (includes loss out exit of jacket).  
 $\rho$ , density of cooling air at inlet of jacket,  
 lb. ft.<sup>-4</sup> sec.<sup>2</sup>  
 $\rho_0$ , standard density (taken as corresponding to  
 29.92 in. Hg and 60° F.), lb. ft.<sup>-4</sup> sec.<sup>2</sup>

$n'$  and  $m$ , exponents.

$K_1$  and  $K_2$ , constants.

In general, the value of  $n'$  is approximately twice that of  $m$  and therefore the temperature ratios of equations (1) and (2) vary as the ratio of the square of the indicated horsepower to the pressure difference across the cylinder. The value of  $T_g$  varies with fuel-air ratio, manifold temperature, and spark timing; but, for normal operating conditions, a value of 1,150° F. for the head and 600° F. for the barrel may be assumed (reference 6).

The temperature ratios for the head and the barrel are shown plotted in figure 11 against  $I^2 / (\Delta p \rho / \rho_0)$ . The curves are for tests made over a range of engine speeds with each fuel system, fuel-air ratio being constant at 0.08. These curves show that the cylinder-temperature data for the three methods of supplying fuel to the engine fall on a single curve which indicates that, for the same engine and cooling conditions, the temperature for all three methods will be the same.

The curves in figure 11 provide approximate equations for the solving of the values of  $T_g$  from the cylinder-temperature data taken in the tests made over a range of fuel-air ratios with each system. These equations are:

$$T_g = 26.05 (T_h - T_a) \left( \frac{\Delta p \rho / \rho_0}{I^2} \right)^{0.31} + T_h \quad (3)$$

for the head and

$$T_g = 13.5 (T_b - T_a) \left( \frac{\Delta p \rho / \rho_0}{I^2} \right)^{0.26} + T_b \quad (4)$$

for the barrel.

The values of  $T_g$  as obtained from these approximate equations provide not only a convenient check on the assumed values of  $T_g$  used in the calculations for figure 11 but also determine whether the effective gas temperature is different for the three methods of mixing the fuel and the air. When the calculated values of  $T_g$  are plotted against fuel-air ratio for the three fuel systems at engine speeds of 1,500 and 1,900 r.p.m. (fig. 12), the data fall around a single curve. At fuel-air ratios less than 0.06, the data are somewhat scattered and cannot be considered as reliable because, although the engine continued to run steadily on very lean mixtures, some of the explosions were weaker than others. Thus the curves of figure 12 show that, for the range of fuel-air ratios tested, the cylinder temperatures will again be the same when the engine and the cooling conditions are the same regardless of the method used for mixing the fuel and the air.

Selection of system for mixing fuel and air.— Although these tests indicate practically no difference in performance with each of the three methods of mixing the fuel and the air except for the gain in power at high speeds with fuel injection into the cylinder, other important factors govern the selection of a fuel system. When a less volatile fuel, such as "safety fuel," is used, the carburetor would be unsatisfactory and the best performance would be obtained by direct injection into the cylinder. When an engine is operated with valve overlap, fuel injection into the cylinder must be employed or else some fuel will be wasted in scavenging the clearance volume. With fuel in-

jected into the cylinder, no difficulty should be experienced with icing.

Other important differences in performance are obtained when the different systems of mixing the fuel and the air are used but, although these differences are favorable to the fuel-injection system, they have not been considered of sufficient importance to warrant its adoption. For instance, tests on multicylinder engines have shown that better starting, acceleration, and maneuverability can be obtained with fuel injection. Well-designed fuel-injection systems give almost perfect distribution of fuel between cylinders. At engine speeds between 2,000 and 3,000 r.p.m., the variation in distribution at full load and part load is less than 1 percent (reference 4). This variation is slightly better than that obtained with a carburetor on a radial engine (reference 7) and should be appreciably better than the distribution on in-line engines equipped with carburetors. Eliminating the fuel-distribution problem in manifold design would be very desirable, especially on in-line engines.

### CONCLUSIONS

1. The power output for each of the three methods of mixing the fuel and the air follows the volumetric efficiency closely and is appreciably higher with fuel injection into the cylinder than with a carburetor or manifold injection. The carburetor offers some restriction to the flow of air; whereas, with fuel injection into the cylinder, very large intake ports and manifold may be used to advantage.

2. For the range of fuel-air ratios from 0.10 to about 0.06, the minimum specific fuel consumption is the same for each of the three methods of air-fuel mixing tried. The engine equipped with a carburetor runs smoothly on the leanest mixture, its performance being slightly better than with fuel injection into the cylinder and considerably better than with manifold injection.

3. For the same power output and cooling conditions, the cylinder temperatures obtained with each method of mixing of the fuel and the air are the same.

Langley Memorial Aeronautical Laboratory,  
National Advisory Committee for Aeronautics,  
Langley Field, Va., January 12, 1939.

## REFERENCES

1. Schey, Oscar W.: Scavenging by Large Valve-Overlap Increases Power and Economy. S.A.E. Jour., vol. 32, no. 6, June 1933, pp. 210-216.
2. Schey, Oscar W., and Young, Alfred W.: Performance of a Fuel-Injection Spark-Ignition Engine Using a Hydrogenated Safety Fuel. T.R. No. 471, N.A.C.A., 1933.
3. Schey, Oscar W., and Clark, J. Denny: Fuel Consumption of a Carburetor Engine at Various Speeds and Torques. T.N. No. 654, N.A.C.A., 1938.
4. Campbell, J. F.: Fuel Injection as Applied to Aircraft Engines. S.A.E. Jour., vol. 36, no. 3, March 1935, pp. 77-88.
5. Taylor, C. F., Taylor, E. S., and Williams, G. L.: Fuel Injection with Spark Ignition in an Otto-Cycle Engine. S.A.E. Jour., vol. XXVIII, no. 3, March 1931, pp. 345-352.
6. Pinkel, Benjamin: Heat-Transfer Processes in Air-Cooled Engine Cylinders. T.R. No. 612, N.A.C.A., 1938.
7. Gerrish, Harold C., and Voss, Fred: Mixture Distribution in a Single-Row Radial Engine. T.N. No. 583, N.A.C.A., 1936.

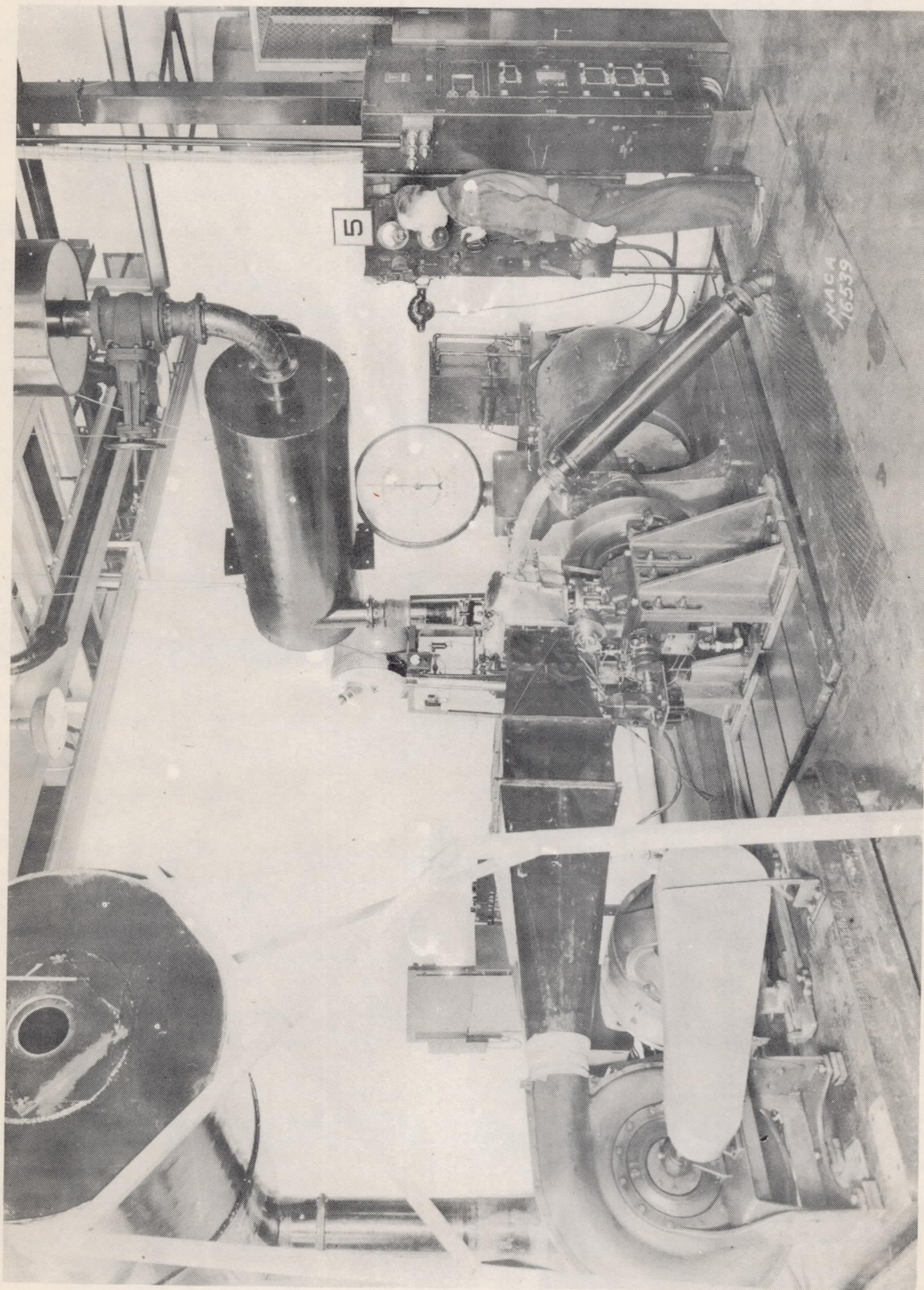

Figure 1.- Set-up of single-cylinder air-cooled test engine.

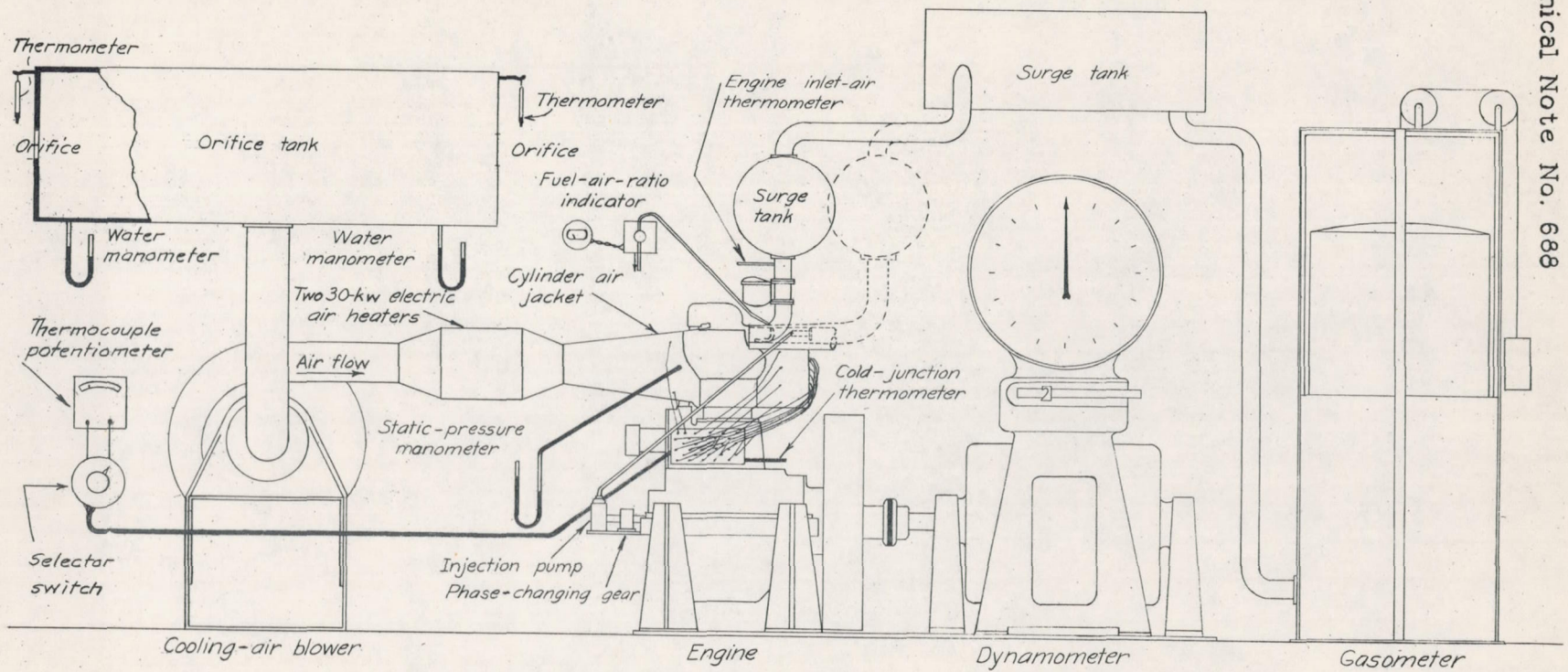
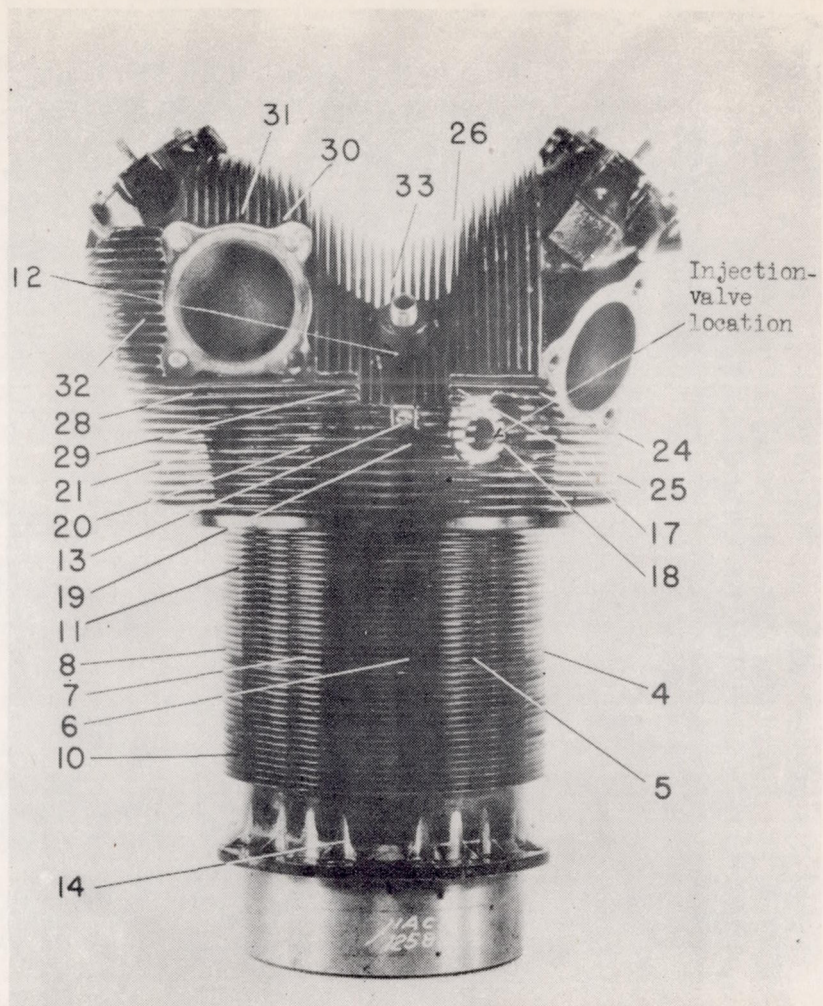
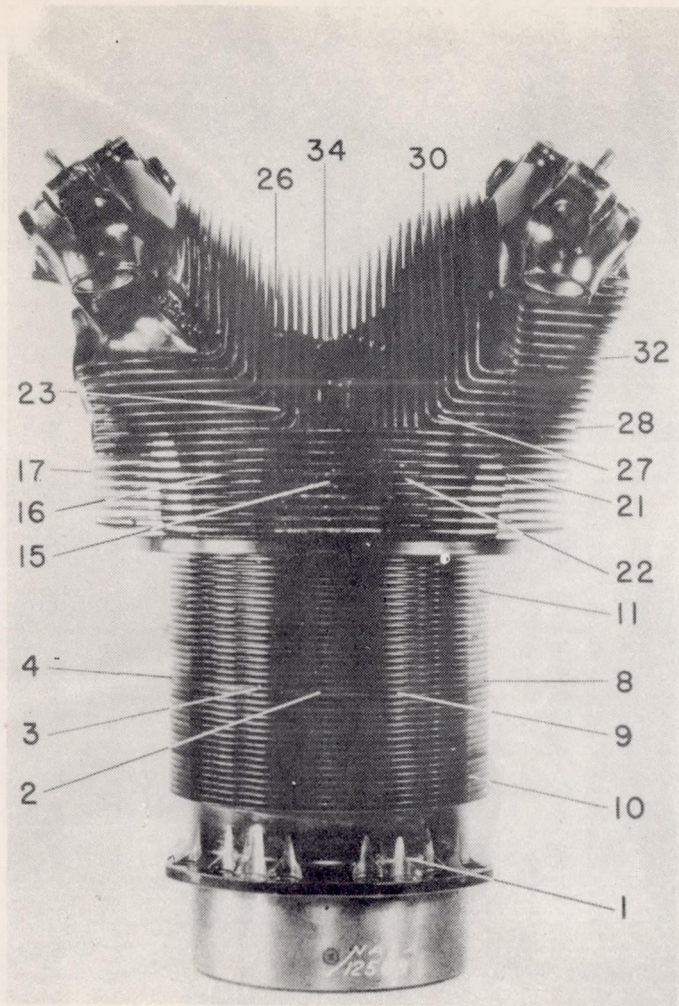

Figure 2.- Diagrammatic layout of equipment.





Front

Rear

Figure 3.- Wright 1820-G cylinder showing injection-valve and thermocouple locations.

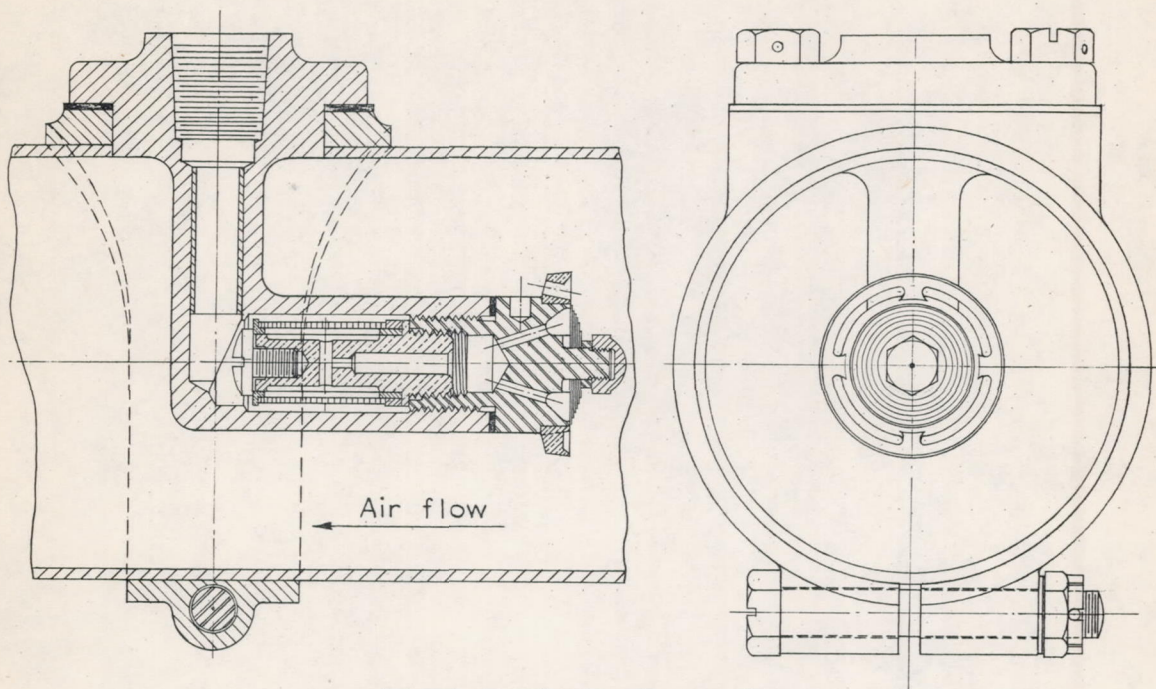

(a) Manifold injection valve.

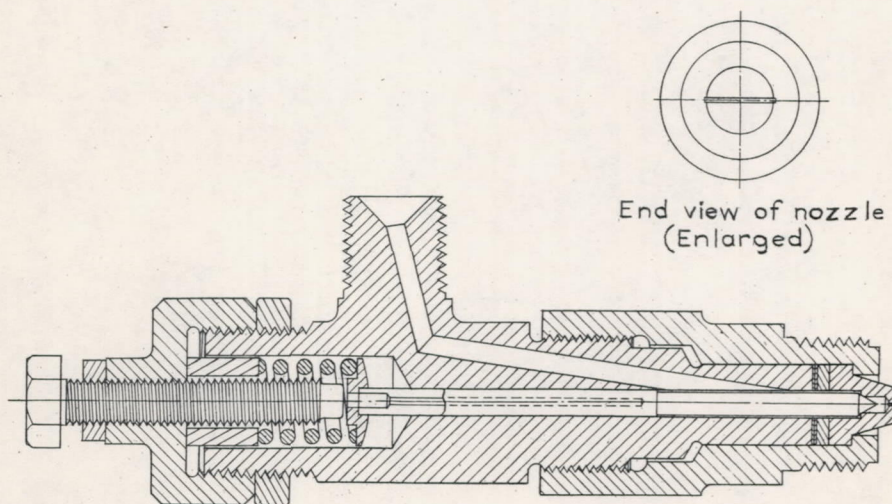

(b) Cylinder injection valve.

Figure 4.- Fuel-injection valves.

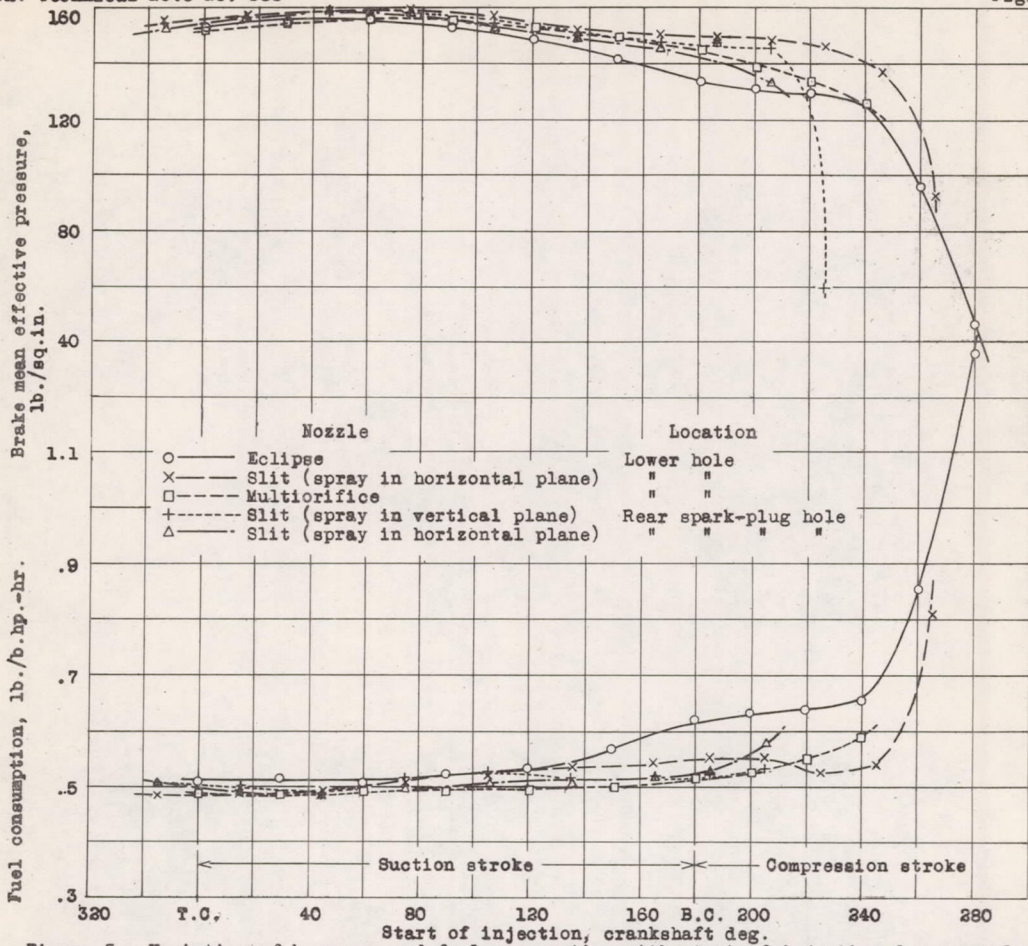

Figure 5.- Variation of b.m.e.p. and fuel consumption with start of injection for several types of nozzle and two injection-valve locations. Valve-opening pressure of 300 lb./sq.in. was used for the Eclipse nozzle and 2,000 lb./sq.in. for the other nozzles. Engine speed, 1,500 r.p.m.

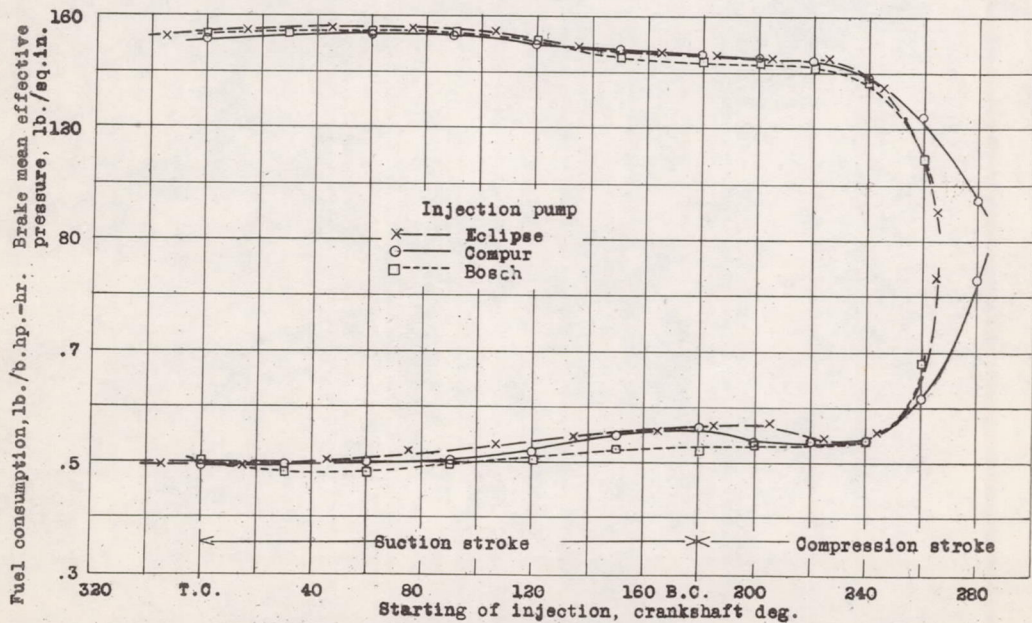

Figure 6.- Variation of b.m.e.p. and fuel consumption with start of injection for three different fuel-injection pumps. Engine speed, 1,500 r.p.m.

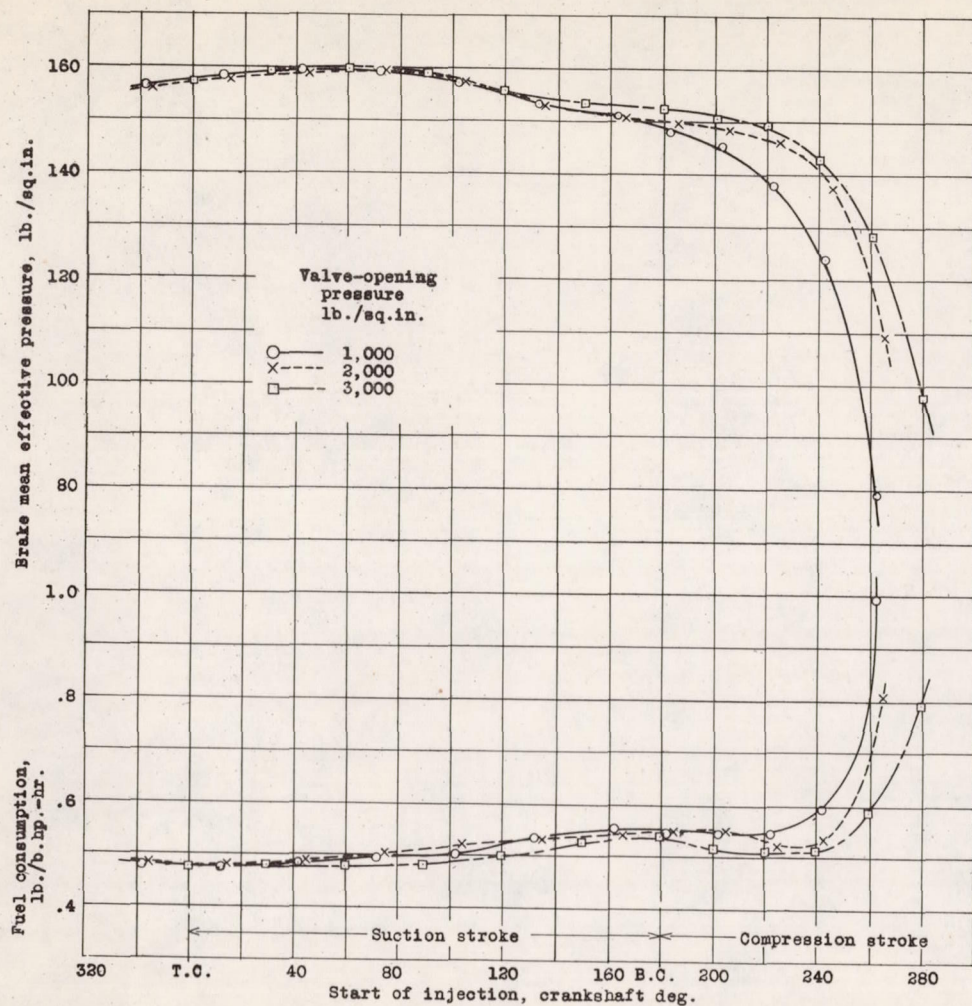

Figure 8.- Variation of b.m.e.p. and fuel consumption with start of injection and with valve-opening pressure. Compur injection pump and slit nozzle.

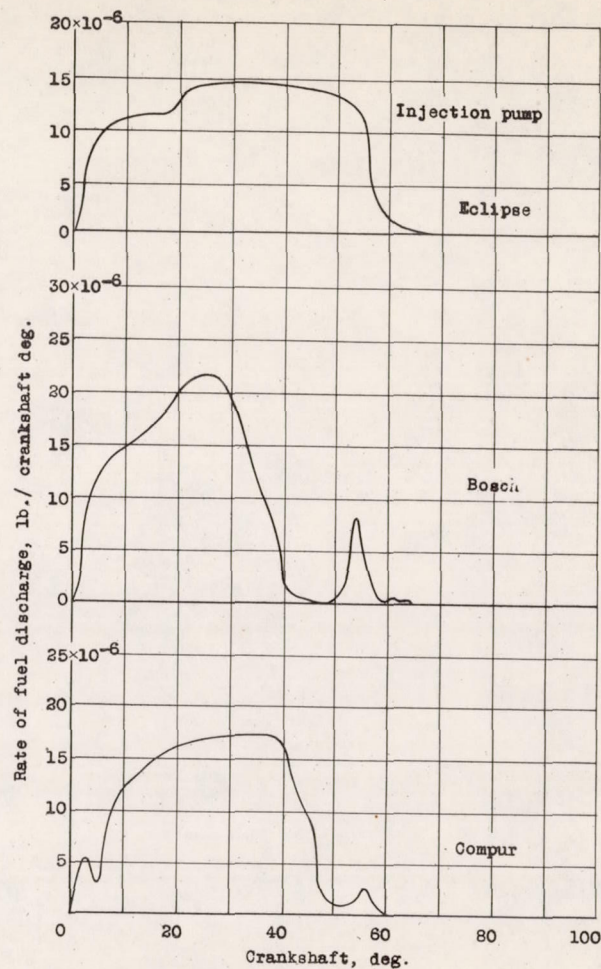

Figure 7.- Length of injection period and rate of discharge for three pumps tested. Slit nozzle with 3,000 lb./sq.in. valve-opening pressure. Engine speed, 1,500 r.p.m.

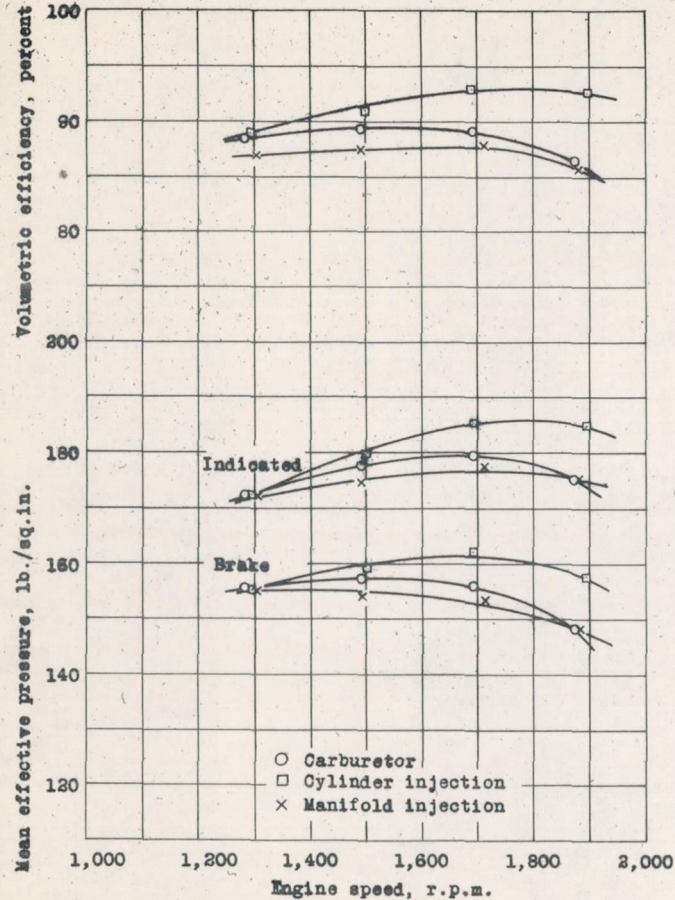

Figure 9.- Variation of engine power and volumetric efficiency with engine speed. Fuel-air ratio, 0.08.

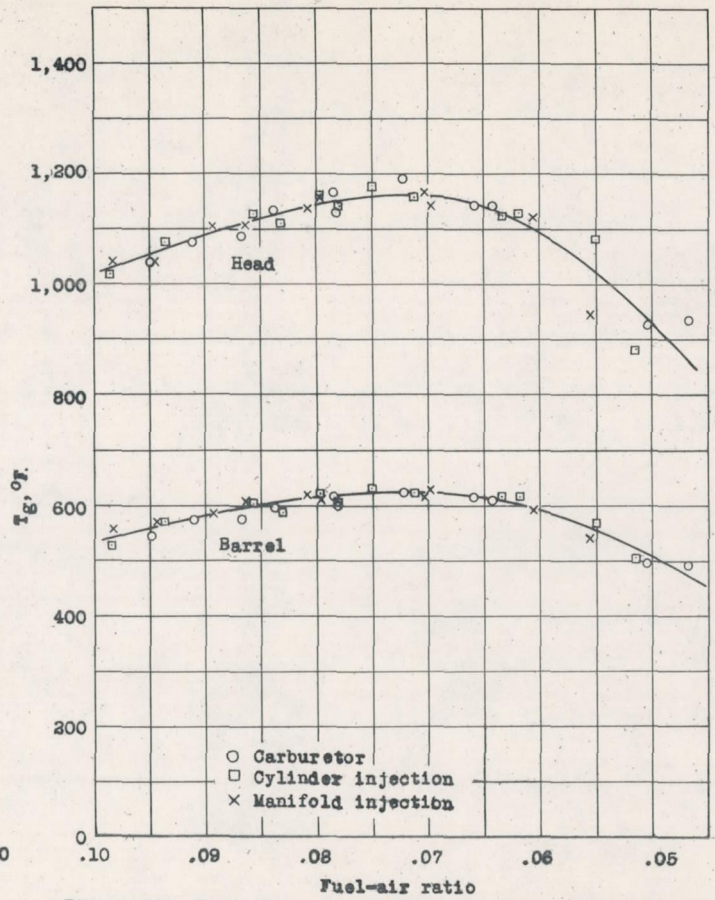

Figure 12.- Variation of the effective gas temperature with fuel-air ratio. Engine speeds, 1,500 and 1,900 r.p.m.

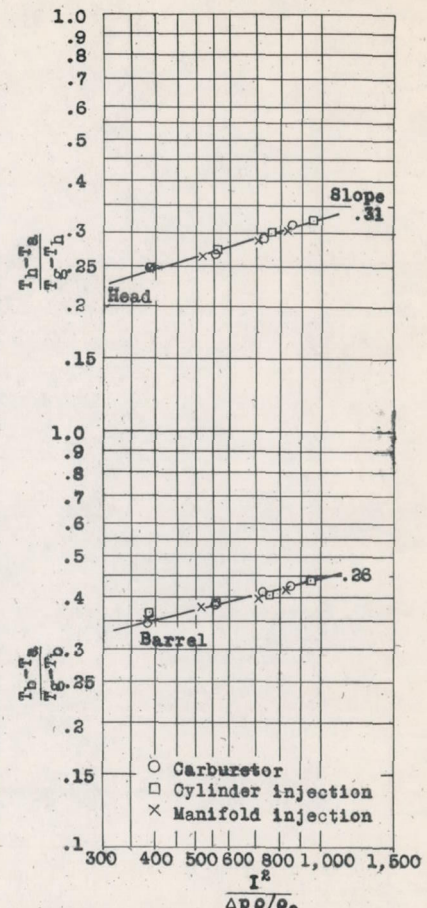

Figure 11.- Comparative engine cooling for three methods of mixing the fuel and the air. Fuel-air ratio, 0.08.

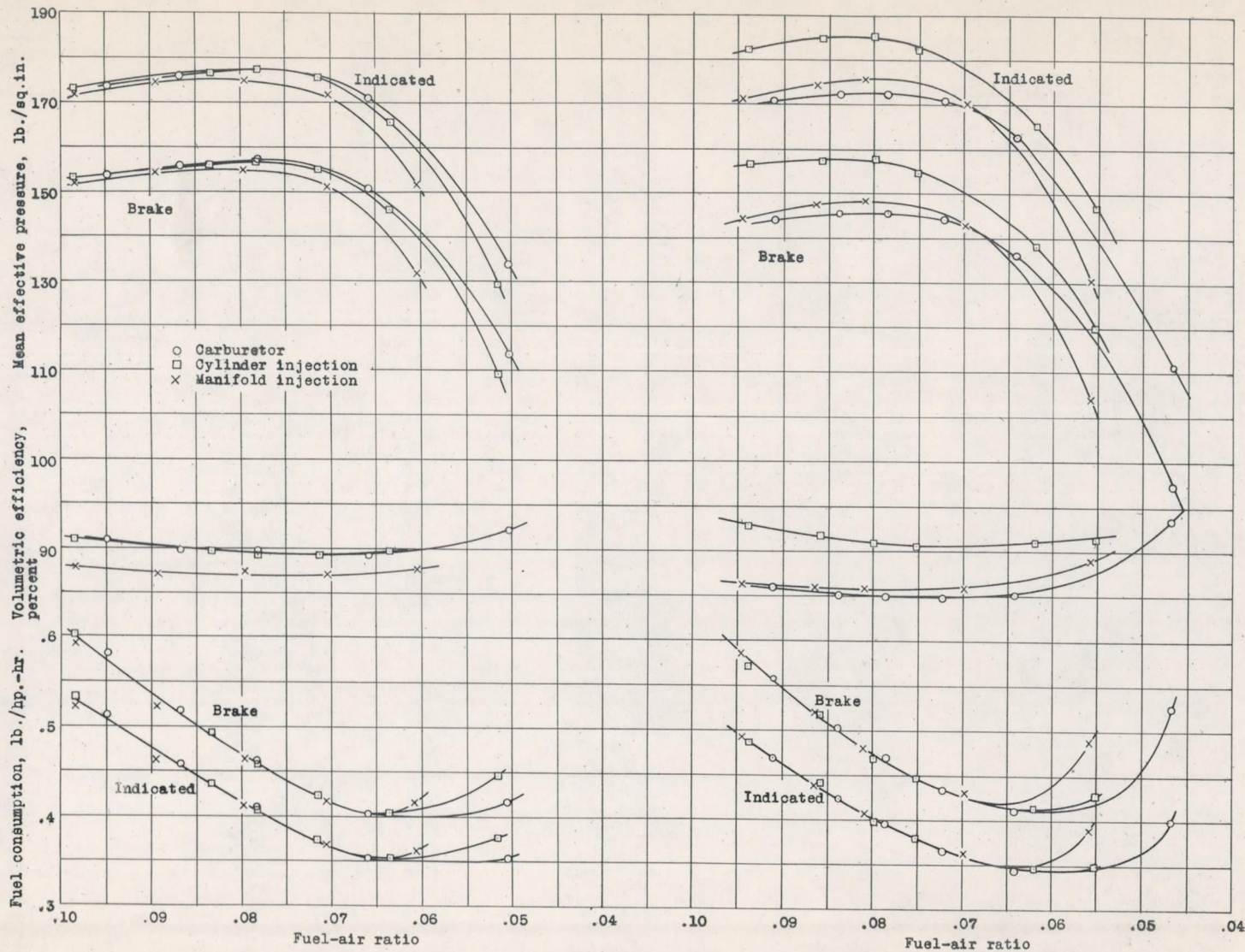

Figure 10a.- Variation of engine power, volumetric efficiency, and specific fuel consumption with fuel-air ratio at 1,500 r.p.m.

Figure 10b.- Variation of engine power, volumetric efficiency, and specific fuel consumption with fuel-air ratio at 1,900 r.p.m.