

CLASSIFICATION DELETED

SEP 6 1943

RESTRICTED

TECHNICAL NOTES

NATIONAL ADVISORY COMMITTEE FOR AERONAUTICS

No. 903

A METHOD FOR DETERMINING THE COLUMN CURVE
FROM TESTS OF COLUMNS WITH EQUAL RESTRAINTS
AGAINST ROTATION ON THE ENDS

By Eugene E. Lundquist, Carl A. Rossman,
and John C. Houbolt

Langley Memorial Aeronautical Laboratory
Langley Field, Va.

CLASSIFIED DOCUMENT

This document contains classified information affecting the National Defense of the United States within the meaning of the Espionage Act, USC 50:31 and 32. Its transmission or the revelation of its contents in any manner to an unauthorized person is prohibited by law. Information so classified may be imparted only to persons in the military and naval Services of the United States, appropriate civilian officers and employees of the Federal Government, who have a legitimate interest therein, and to United States citizens of known loyalty and discretion who of necessity must be informed thereof.

N A C A LIBRARY
LANGLEY MEMORIAL AERONAUTICAL
LABORATORY
Langley Field, Va.

Washington
August 1943



3 1176 01433 8082

NATIONAL ADVISORY COMMITTEE FOR AERONAUTICS

TECHNICAL NOTE NO. 903

A METHOD FOR DETERMINING THE COLUMN CURVE
FROM TESTS OF COLUMNS WITH EQUAL RESTRAINTS
AGAINST ROTATION ON THE ENDS

By Eugene E. Lundquist, Carl A. Rossman,
and John C. Houbolt

SUMMARY

The results are presented of a theoretical study for the determination of the column curve from tests of column specimens having ends equally restrained against rotation. The theory of this problem is studied and a curve is shown relating the fixity coefficient c to the critical load, the length of the column, and the magnitude of the elastic restraint. A method of using this curve for the determination of the column curve for columns with pin ends from tests of columns with elastically restrained ends is presented. The results of the method as applied to a series of tests on thin-strip columns of stainless steel are also given.

INTRODUCTION

It is fairly common practice for engineers to assume that a given fixture or restraining member at the end of a column provides a column fixity coefficient c that is constant for columns of different lengths and sizes of column cross sections. In reality, however, the fixity coefficient depends upon both the dimensions of the column and the restraint offered by the restraining member; therefore, a more correct procedure, theoretically, would be to assume that a given fixture or restraining member at the end of the column provides, rather than a given fixity coefficient, a restraining stiffness against rotation that is independent of the dimensions of the column. A method for determining the column curve for thin sheet

material that is based upon considerations of the restraining stiffness and that shows promise of successful development involves mounting each end of a small column specimen in special end fixtures of the general type shown in figure 1. The specimen with end fixtures attached is then loaded by axially compressing the assembly until the specimen fails by instability as an ordinary column.

The special end fixtures on the column specimen in figure 1 tend to produce a condition approaching that of completely fixed ends. Actually, the elasticity of the clamping fixtures and of the specimen does not permit completely fixed ends and, as a consequence, the column fixity coefficient c , which is 1 for pin ends and 4 for fixed ends, will be slightly less than 4.

The method of analyzing test data to obtain the column curve for any thin sheet material, tested in the manner described, is presented herein. Column curves that have been determined in this manner for a series of stainless-steel specimens are also presented.

DETERMINATION OF COLUMN CURVE FOR $c = 1$

The column curve that is usually plotted for any material is the curve for pin-ended columns, $c = 1$. In order to obtain the column curve from tests employing the end fixtures shown in figure 1, the value of the column fixity coefficient c must be determined. This coefficient c can be determined by use of the curve of figure 2 provided the length of the column L , the experimental critical buckling load of the column P_{cr} , and the restraining stiffness of the end fixtures m (assumed to be the same at each end), are known. The curve shown in figure 2 is the graph of the equation

$$\frac{P_{cr}L^2}{m} = \pi^2 \sqrt{c} \tan\left(\frac{\pi}{2} \sqrt{c}\right)$$

which has been determined through consideration of the stability of a column having ends equally restrained against rotation and is a special case of the general solution given by equation (A-13) in the appendix.

After the value of c has been found, the effective value of the slenderness ratio L/ρ for the fixity coefficient $c = 1$ can be determined by use of the following relation:

$$\left(\frac{L}{\rho}\right)_{\text{eff}} = \frac{1}{\sqrt{c}} \left(\frac{L}{\rho}\right)_{\text{exp}}$$

where

$\left(\frac{L}{\rho}\right)_{\text{eff}}$ effective slenderness ratio for $c = 1$

$\left(\frac{L}{\rho}\right)_{\text{exp}}$ actual slenderness ratio of tested column

and

ρ radius of gyration of column.

The column curve for pin ends is obtained by plotting

P_{cr}/A against $\left(\frac{L}{\rho}\right)_{\text{eff}}$ for the specimens tested, where

A is the cross-sectional area of the specimen.

EVALUATION OF RESTRAINT m

Before the fixity coefficient c can be evaluated by the procedure given in the foregoing section, the value of the restraint m of each end fixture must be known. In the case of the end fixture of figure 1, the specimen is so narrow compared to the width of the fixture that probably only a part of the fixture is elastically restraining the rotation of the end of the specimen. It is, therefore, likely that the restraint m depends on the width of the specimen and should be evaluated for each different width. The value of m for any group of column specimens of the same width and thickness can be determined from the test data for the longer specimens of the group, because the critical compressive stress for these specimens is low and lies within the elastic range where

the effective modulus \bar{E} is equal to Young's modulus E . For these longer test specimens, all quantities in the Euler column formula are known except c . Therefore

$$c = \frac{P_{cr}L^2}{\pi^2 EI} \quad (1)$$

The value of $\frac{P_{cr}L}{m}$ corresponding to this value of c may be found from the graph of figure 2; then m can be computed because P_{cr} and L are known. When m has been determined, the evaluation of c for the columns of shorter lengths can be made as described in the preceding section.

In order to retain the degree of accuracy required in computations, the curve of figure 2 should be plotted to an enlarged scale. As an aid in preparing such a curve, a set of coordinates of the curve is given in table 1.

RESULTS OF TESTS OF STAINLESS-STEEL COLUMNS OF THIN SHEET MATERIAL

The method for determining the column curve as described in this report has been applied to eight series - designated A, B, C, etc. - of stainless-steel column specimens. The heat treatment and condition of loading for each series is given in table 2. The chemical analysis for each series is as follows:

Chemical element	Percentage composition			
	Series			
	A, B, C, and D	E	F	G and H
Fe	71.925	72.238	27.009	} Not available
C	.08	.11	.04	
Mn	.63	1.63	1.40	
P	.016	.024	.014	
S	.009	.008	.007	
Si	.45	.46	43.00	
Ni	8.71	7.35	10.13	
Cr	18.16	18.16	18.00	
Cu	.02	.02	.02	
Ti	—	—	.38	

The column tests were made of flat strips with the type of fixture shown in figure 1. The specimens were loaded in a standard 100,000-pound-capacity hydraulic testing machine. The heads of the testing machine were set parallel and the specimens were centered to produce as nearly an axial load condition as possible. The testing machine was of the two-screw type and the column specimens were so positioned that failure would occur in the plane of the screws of the machine, as the stiffness of the testing machine is greatest in this plane.

The values of E were obtained from stress-strain tests of column specimens from each series of columns tested. A tensile modulus was used in the analysis of several series because it was not possible to determine the compressive modulus. A summary of the values of E and of restraint values m found for the different series is given in table 2.

Table 3 shows the computations necessary to analyze series A by the method outlined previously in this report; the column curve for series A is shown in figure 3. Graphs of the results of the tests, in which critical stress has been plotted against slenderness ratio for $c = 1$, are shown in figures 3 to 10.

EFFECT OF ERRORS IN E ON DERIVED COLUMN CURVE

The application of the procedures outlined in this report to the data obtained from the tests of the stainless-steel columns revealed that the accuracy of the resulting column curve depended on the choice of the value of E used in the evaluation of the restraint m . A study was therefore made to determine the effect that errors in E would have on the final column curve. The results of this study revealed that (see fig. 11):

1. At any value of $(L/\rho)_{\text{eff}}$ the stress given by a derived column curve based upon a value of E smaller than the correct value will be in error on the conservative or low side as compared with the curve derived by using the correct value of E . For a given percentage error in E , a low value of E will give, over the most practical range of $(L/\rho)_{\text{eff}}$, a smaller percentage error in column stress than will a correspondingly high value of E .

2. The maximum percentage error in stress given by a column curve derived by using an incorrect value of E is greater than the percentage error in E (see fig. 11). It is therefore important that the compression modulus for the material of the column specimens be accurately known if a column curve is derived by the method given in this report.

3. If the correct value of E is unknown and a commonly accepted value of E is assumed for use in the computations, the analysis should reveal the presence of any unreasonably large errors in this choice of E . If the value of E is too large, the derived column curve will lie above the Euler curve for this value of E in the range of intermediate column lengths (see fig. 12). If the value of E used in the evaluation of m from the test data for the longer specimens of the group is sufficiently less than the correct value of E , the computed value of the fixity coefficient, as given by equation (1), will be greater than 4.

Consideration of the foregoing facts indicates that, if the value of E is uncertain but is known to lie within a small range, the lowest value in that range would be the most suitable value to select for use in computing the column curve of the material.

Langley Memorial Aeronautical Laboratory,
National Advisory Committee for Aeronautics,
Langley Field, Va., June 10, 1943.

APPENDIX

THE STABILITY OF A COLUMN HAVING ELASTICALLY RESTRAINED ENDS

Timoshenko has obtained the expressions for the rotations θ_a and θ_b at the ends of a member subjected to compressive forces P and end moments M_a and M_b (shown in fig. 13) by solving the differential equation expressing the equilibrium of the bent member. These expressions, given as equation (25) on page 13 of reference 1, are:

$$\theta_a = \frac{M_a LG}{3EI} + \frac{M_b LF}{6EI} \quad (A-1)$$

$$\theta_b = \frac{M_b LG}{3EI} + \frac{M_a LF}{6EI} \quad (A-2)$$

where

$$F = \varphi(u) = \frac{3}{u} \left(\frac{1}{\sin 2u} - \frac{1}{2u} \right) \quad (A-3)$$

$$G = \psi(u) = \frac{3}{2u} \left(\frac{1}{2u} - \frac{1}{\tan 2u} \right) \quad (A-4)$$

$$u = \frac{kL}{2} \quad (A-5)$$

$$k = \sqrt{\frac{P}{EI}} \quad (A-6)$$

In the foregoing equations the symbols have the following meanings:

- θ_a, θ_b rotations of the tangents to deflection curve at the left and right ends, respectively, of the member; positive as shown in figure 13
- M_a, M_b applied moments at the left and right ends, respectively, of the member as shown in figure 13
- L length of the member
- E effective modulus of elasticity
- I moment of inertia of the column cross section
- P axial load acting on the member

If the moments M_a and M_b in equations (A-1) and (A-2) arise as a result of rotation of the restraining elements that oppose the deflection of the member when it bends and if, in addition, the restraining moments are proportional to the rotations of the restraining elements, respectively, the end moments acting on the member can be written

$$M_a = -m_a \theta_a \quad (A-7)$$

$$M_b = -m_b \theta_b \quad (A-8)$$

where m_a and m_b are the moments necessary to rotate the restraining elements at the left and right ends of the column, respectively, through one radian.

Substitution of these values of M_a and M_b in equations (A-1) and (A-2) gives

$$\left(1 + \frac{Ge_a}{3}\right) \theta_a + \left(\frac{Fe_b}{6}\right) \theta_b = 0 \quad (A-9)$$

$$\left(\frac{P\epsilon_a}{6}\right)\theta_a + \left(1 + \frac{G\epsilon_b}{3}\right)\theta_b = 0 \quad (A-10)$$

where

$$\epsilon_a = \frac{m_a L}{EI} \quad (A-11)$$

$$\epsilon_b = \frac{m_b L}{EI} \quad (A-12)$$

The quantities ϵ_a and ϵ_b are the "restraint coefficient" at the left and right ends, respectively, of the compression member. ✓

Equations (A-9) and (A-10) are linear simultaneous equations which can be satisfied by taking $\theta_a = \theta_b = 0$. The deflection at each point on the member is then zero and the straight form of equilibrium of the member is obtained. The buckled form of equilibrium of the member becomes possible only if equations (A-9) and (A-10) yield for θ_a and θ_b solutions different from zero, which requires that the determinant of these equations become zero, or

$$\left(1 + \frac{G}{3}\epsilon_a\right)\left(1 + \frac{G}{3}\epsilon_b\right) - \left(\frac{P}{6}\epsilon_a\right)\left(\frac{P}{6}\epsilon_b\right) = 0 \quad (A-13)$$

The value of P that satisfies this equation for neutral stability of a member elastically restrained against rotation at each end is the critical load P_{cr} .

When the restraints at the ends of the column are equal, $m_a = m_b = m$ and $\epsilon_a = \epsilon_b = \epsilon$. For this case equation (A-13) reduces to

$$\left(1 + \frac{G}{3}\epsilon\right)^2 = \left(\frac{P}{6}\epsilon\right)^2 \quad (A-14)$$

This equation cannot be solved directly for P_{cr} , the critical value of the load P , because P occurs in

transcendental expressions F and G . If P is regarded as known, however, equation (A-14) yields as solutions for ϵ two values

$$\epsilon = \frac{1}{\frac{F}{6} - \frac{G}{3}} \quad (\text{A-15})$$

$$\epsilon = \frac{-1}{\frac{F}{6} + \frac{G}{3}} \quad (\text{A-16})$$

which describe two mathematically possible buckling configurations. The buckled shape that corresponds to each of these equations may be obtained by substituting the value of ϵ in either equation (A-9) or equation (A-10). From this substitution of ϵ as given by equation (A-15) it is found that $\theta_a = -\theta_b$, which by the aid of equations (A-7) and (A-8) shows that $M_a = -M_b$. This type of buckling is represented by the bent member of figure 14(a). Similarly, by substitution of the value of ϵ as given by equation (A-16) in either equation (A-9) or (A-10), it is found that $\theta_a = \theta_b$, which again by the aid of equations (A-7) and (A-8) shows that $M_a = M_b$. This type of buckling is illustrated by figure 14(b).

The type of buckling shown in figure 14(b) will occur at a lower load than the type shown in figure 14(a) because of the longer wave length involved. A column with equal elastic restraints resisting rotation at its ends will therefore adopt the buckling configuration shown in figure 14(b) at a load $P = P_{cr}$ that satisfies equation (A-16).

When the values of F and G as given by equations (A-3) and (A-4) are substituted in equation (A-16), the following relation is obtained:

$$\epsilon = \frac{-2u}{\tan \frac{2u}{2}} \quad (\text{A-17})$$

From equations (A-5) and (A-6)

$$2u = \sqrt{\frac{P}{EI}} L \quad (A-18)$$

By use of the relationship expressed by the Euler column formula,

$$P_{cr} = \frac{c\pi^2 EI}{L^2} \quad (A-19)$$

equation (A-18) becomes

$$2u = \pi\sqrt{c} \quad (A-20)$$

Equation (A-17) may therefore be expressed as

$$\epsilon = \frac{-\pi\sqrt{c}}{\tan \frac{\pi\sqrt{c}}{2}} \quad (A-21)$$

This expression for the elastic restraint at the ends of a column in terms of the fixity coefficient is shown graphically in figure 15 in order to show that the variation in the fixity coefficient is small when the restraint is large.

If the equations (A-11) or (A-12), which define ϵ , are solved for EI/L when $m_a = m_b = m$ and this value is substituted in equation (A-19), the Euler column formula can be written

$$P_{cr} = \frac{c\pi^2}{L} \frac{m}{\epsilon} \quad (A-22)$$

Substitution of the value of ϵ as given by equation (A-21) in equation (A-22) gives

$$P_{cr} = - \frac{m\pi\sqrt{c} \tan\left(\frac{\pi}{2}\sqrt{c}\right)}{L}$$

Multiplication of both sides of this equation by L/m results in the equation

$$\frac{P_{cr}L}{\pi} = -\pi \sqrt{c} \tan \left(\frac{\pi}{2} \sqrt{c} \right) \quad (A-23)$$

Equation (A-23) relates the fixity coefficient c to the critical load, the length of the column, and the magnitude of the elastic restraint. This equation is represented graphically in figure 2.

REFERENCE

1. Timoshenko, S.: Theory of Elastic Stability. McGraw-Hill Book Co., Inc., 1936.

TABLE 1.-- VALUES OF $\frac{P_{cr}L}{m}$ AND CORRESPONDING VALUES OF c

c	$\frac{P_{cr}L}{m}$	c	$\frac{P_{cr}L}{m}$	c	$\frac{P_{cr}L}{m}$
1.00	∞	2.68	3.29718	3.64	0.87342
1.10	42.8911	2.72	3.18358	3.66	.82544
1.20	22.7811	2.76	3.07200	3.68	.77740
1.30	16.0036	2.80	2.96222	3.70	.72930
1.40	12.5572	2.84	2.85420	3.72	.68120
1.50	10.4425	2.88	2.74758	3.74	.63301
1.60	8.9920	2.92	2.64247	3.76	.58486
1.70	7.9206	2.96	2.53852	3.78	.53658
1.80	7.0853	3.00	2.43581	3.80	.48816
1.84	6.79802	3.04	2.33406	3.81	.46401
1.88	6.53224	3.08	2.23329	3.82	.43979
1.92	6.28489	3.12	2.13326	3.83	.41554
1.96	6.05359	3.16	2.03401	3.84	.39128
2.00	5.83651	3.20	1.93544	3.85	.36704
2.04	5.63180	3.24	1.83740	3.86	.34269
2.08	5.43821	3.28	1.73980	3.87	.31839
2.12	5.25432	3.32	1.64271	3.88	.29406
2.16	5.07920	3.36	1.54594	3.89	.26966
2.20	4.91177	3.40	1.44946	3.90	.24534
2.24	4.75145	3.42	1.40135	3.91	.22095
2.28	4.59737	3.44	1.35326	3.92	.19645
2.32	4.44916	3.46	1.30518	3.93	.17202
2.36	4.30597	3.48	1.25712	3.94	.14753
2.40	4.16748	3.50	1.20918	3.95	.12304
2.44	4.03316	3.52	1.16117	3.96	.098491
2.48	3.90272	3.54	1.11321	3.97	.073821
2.52	3.77577	3.56	1.06525	3.98	.049343
2.56	3.65200	3.58	1.01731	3.99	.024617
2.60	3.53117	3.60	.96936	4.00	.000000
2.64	3.41288	3.62	.92144		

TABLE 2

SUMMARY OF PROPERTIES OF STAINLESS-STEEL COLUMNS

[All specimens were supplied by Fleetwings, Inc.; series A, B, C, D from roll No. 4460; E from roll No. 2346, heat No. 7189; F from roll No. 639, heat No. 7223; and G and H are type 322 "W"]

Series	Grain	Heat treatment	Hardness description	Ultimate stress (lb/sq in.)	Yield stress (lb/sq in.)	Elongation (percent)	Hardness (Rockwell number)	E (lb/sq in.)			m (lb-in.)
								Tensile	Compressive	Peak	
A	Longitudinal	Not heat-treated	Full hard	185,000 to 186,500	148,200 to 149,800	9.5 to 10.0	C-38	^a 25.10 × 10 ⁶	^a 26.3 × 10 ⁶	^a 25.85 × 10 ⁶	740
B	Longitudinal	400° F for 72 hr	Full hard	-----	-----	-----	-----	^a 26.12	-----	-----	1690
C	Transverse	Not heat-treated	Full hard	185,900 to 187,800	148,200 to 158,000	10.0	C-38	^a 27.35	-----	-----	∞
D	Transverse	200° C for 72 hr	Full hard	-----	-----	-----	-----	^a 26.85	-----	-----	1580
E	Longitudinal	-----	1/2 hard	166,600	-----	26.0	C-34	^a 25.87	-----	-----	540
F	Longitudinal	-----	Annealed	83,200	-----	65.0	B-68	^a 26.73	-----	-----	∞
G	Transverse	900° F for 1 hr	Full hard	-----	-----	-----	-----	30.75	^a 29.0	-----	1200
H	Longitudinal	900° F for 1 hr	Full hard	-----	-----	-----	-----	29.15	^a 29.17	-----	440

NACA Technical Note No. 903

^aThese values of E were used to determine m and are the values used in the analysis of the test data.

TABLE 3

ANALYSIS OF TEST DATA OBTAINED FROM SERIES A OF STAINLESS-STEEL COLUMN SPECIMENS

Evaluation of m											
L (in.)	b (in.)	t (in.)	P_{cr} (lb)	E (lb/sq in.)	I (in. ⁴)	$c = \frac{P_{cr}L}{\pi^2 EI}$	$\frac{P_{cr}L}{m}$ (From fig. 2)	$P_{cr}L$ (lb-in.)	m (lb-in.)		
2.4505	0.31998	0.02997	118.51	25.85×10^6	0.71758×10^{-6}	3.8873	0.2580	290.41	1126		
2.1832	.31965	.03001	145.17	25.85	.72045	3.7644	.5741	316.94	552		
1.9110	.31978	.0300	187.54	25.85	.71951	3.7310	.6546	358.89	548		
									Ave. = 740		
Evaluation of $(L/\rho)_{eff}$											
L (in.)	b (in.)	t (in.)	ρ (in.)	A (sq in.)	P_{cr} (lb)	$\frac{P_{cr}L}{m}$	c (From fig. 2)	\sqrt{c}	L/ρ	$(L/\rho)_{eff}$	$\frac{P_{cr}}{A}$ (lb/sq in.)
2.4505	0.3200	0.0300	0.00866	0.009589	118.51	0.2580	3.8873	1.9716	283.0	143.5	12,359
2.1832	.3199	.0300	.00867	.009549	145.17	.5741	3.7644	1.9402	251.7	129.7	15,123
1.9110	.3198	.0300	.00867	.009593	187.54	.6546	3.7310	1.9318	220.4	114.1	19,549
1.4779	.3202	.0300	.00868	.009618	300.34	.5998	3.754	1.9375	170.2	87.9	31,226
1.1787	.3197	.0298	.00861	.009527	414.34	.6589	3.729	1.9311	136.6	70.6	43,492
1.1767	.3192	.0300	.00866	.009560	446.34	.7097	3.708	1.9256	135.9	70.6	46,688
1.0262	.3202	.0298	.00861	.009542	507.84	.7043	3.7105	1.9263	119.2	61.9	53,221
1.0272	.3204	.0298	.00861	.009545	527.97	.7329	3.6975	1.9229	119.3	62.1	55,311
.8842	.3203	.0297	.00858	.009511	631.84	.7550	3.6895	1.9201	103.0	53.7	66,430
.8872	.3198	.0297	.00858	.009498	578.84	.6940	3.715	1.9274	103.4	53.6	60,943
.7402	.3206	.0298	.00861	.009552	702.84	.7050	3.711	1.9264	85.9	44.6	73,577
.7406	.3209	.0298	.00861	.009561	755.34	.7560	3.689	1.9207	86.0	44.8	79,000
.5909	.3198	.0298	.00861	.009531	869.72	.6945	3.715	1.9274	68.6	35.6	91,250
.5164	.3203	.0300	.00866	.009597	1009.04	.7042	3.7105	1.9263	59.6	31.0	105,150
.4418	.3194	.0300	.00866	.009566	1111.09	.6634	3.7275	1.9307	51.0	26.4	116,150
.3658	.3196	.0298	.00861	.009516	1246.34	.6160	3.747	1.9357	42.5	22.0	130,980
.2911	.3201	.0298	.00860	.009530	1412.04	.5554	3.7745	1.9428	33.8	17.4	148,170

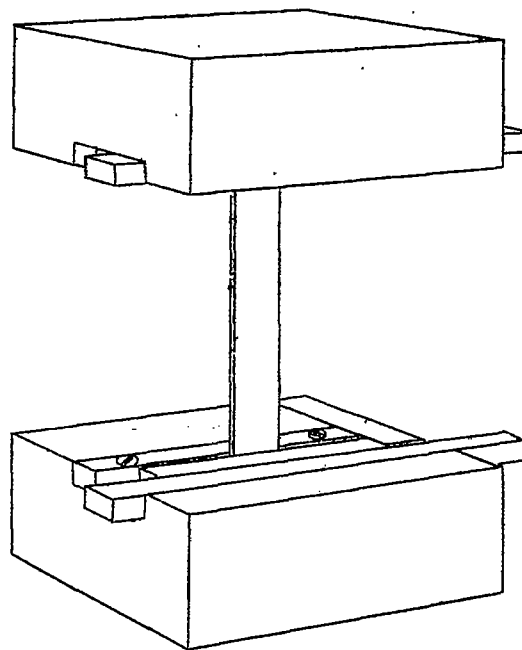

Figure 1.- Column and end fixtures assembly.

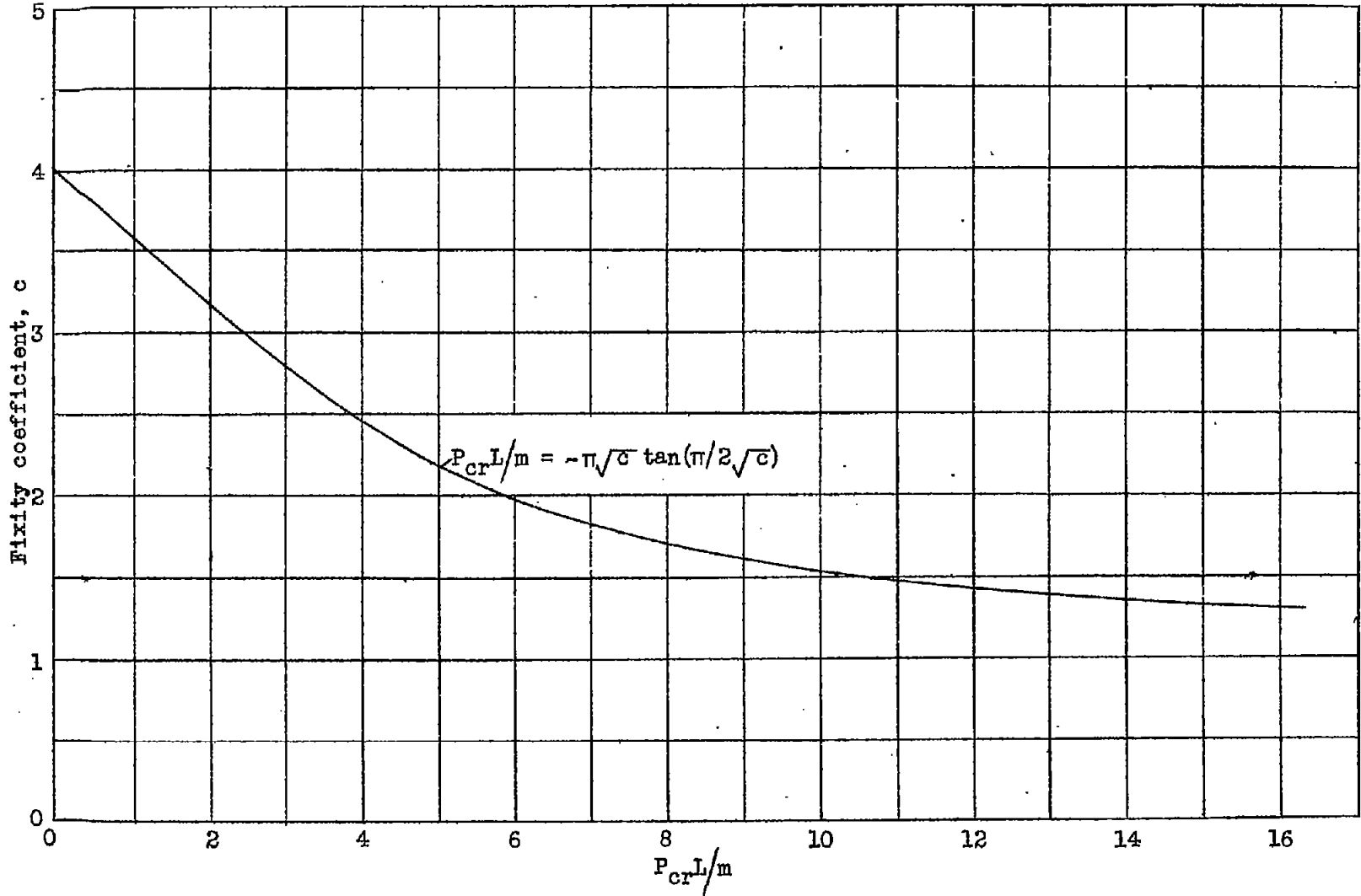

Figure 2.- Relationship of $P_{cr}L/m$ and c for columns equally elastically restrained against rotation at each end.

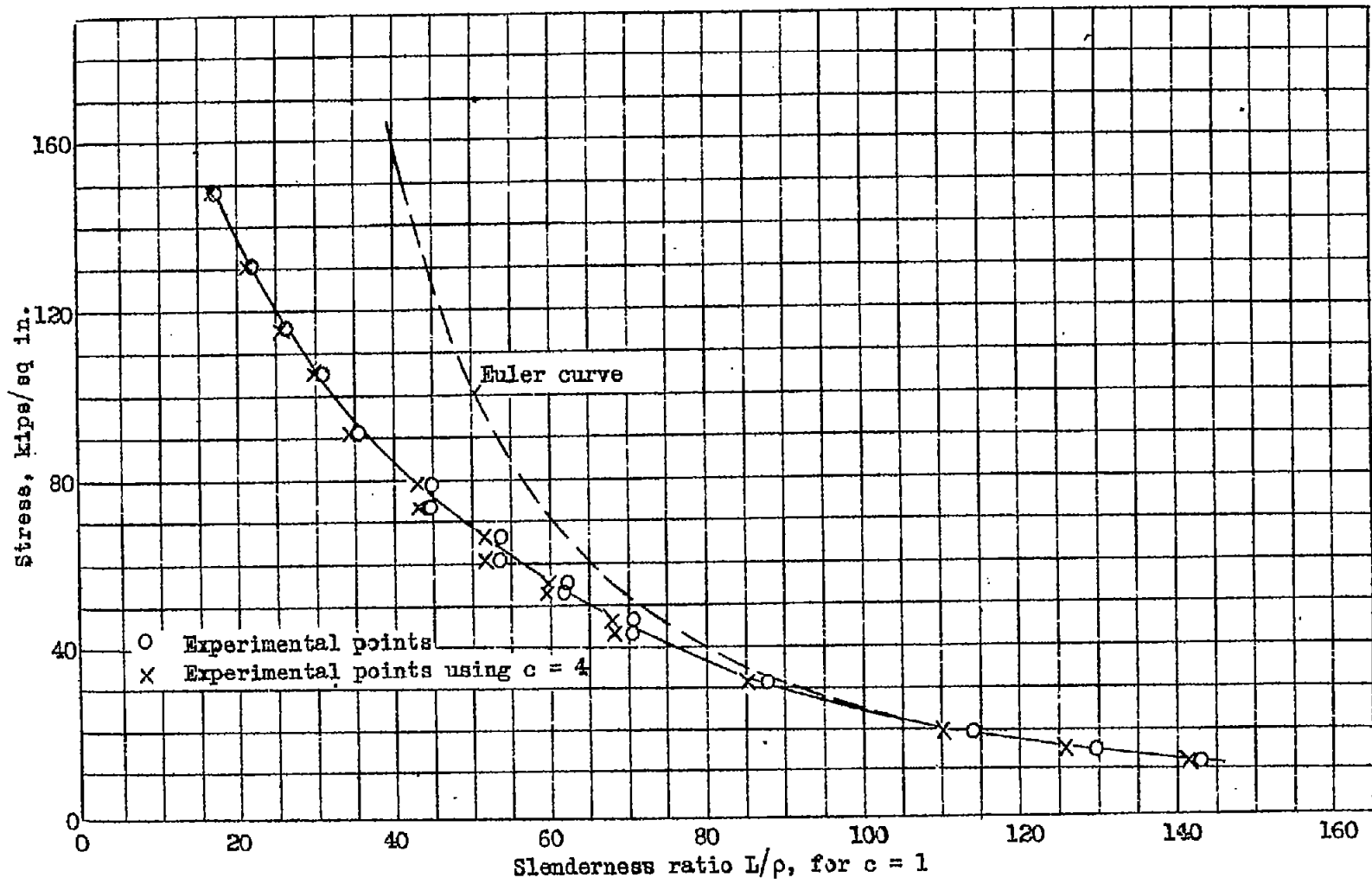

Figure 3.- Column curve for full-hard stainless steel, 0.030 inch thick, not heat-treated; loaded with grain. Series A.

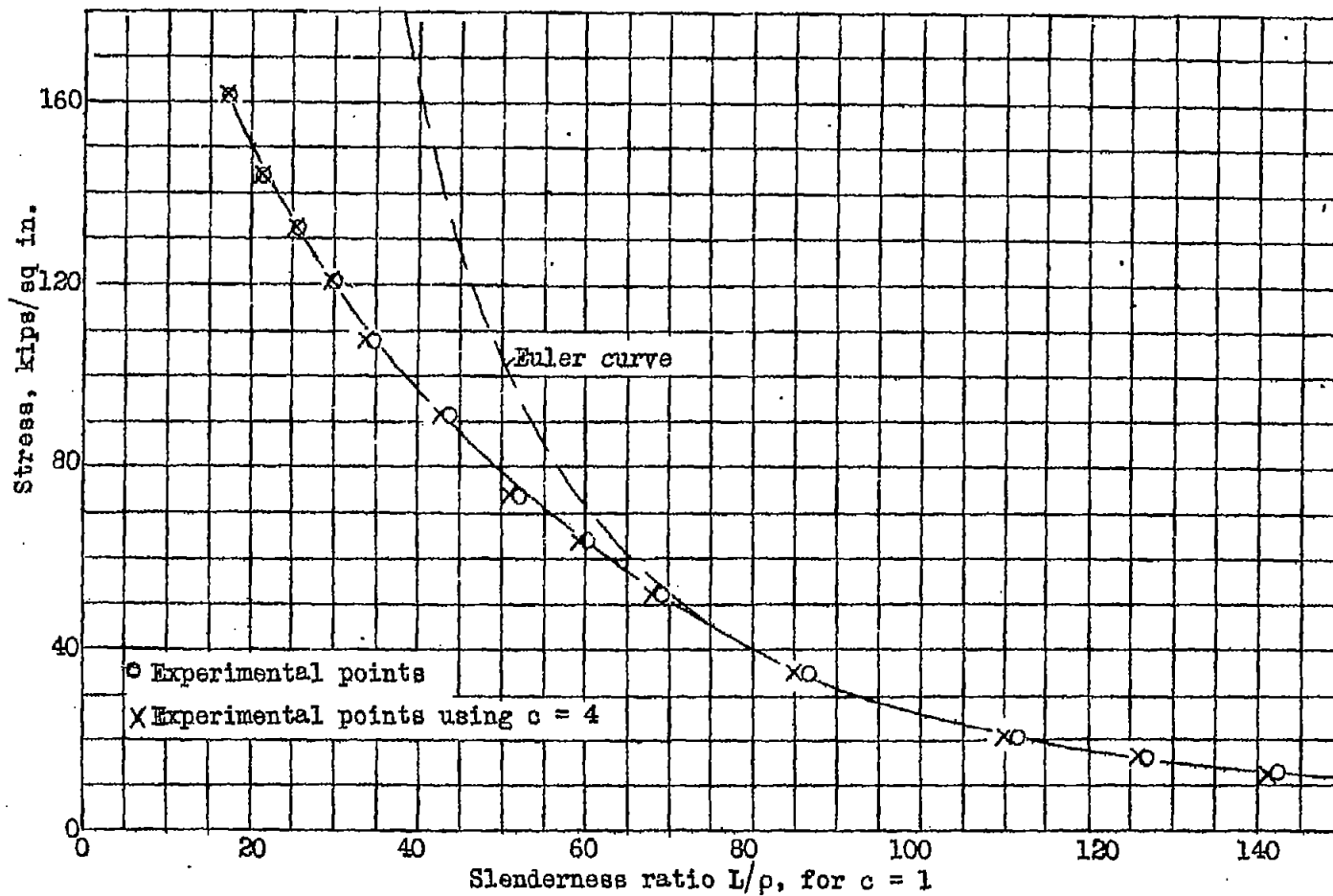

Figure 4 .- Column curve for full-hard stainless steel, 0.030 inch thick, heat-treated; loaded with grain. Series B.

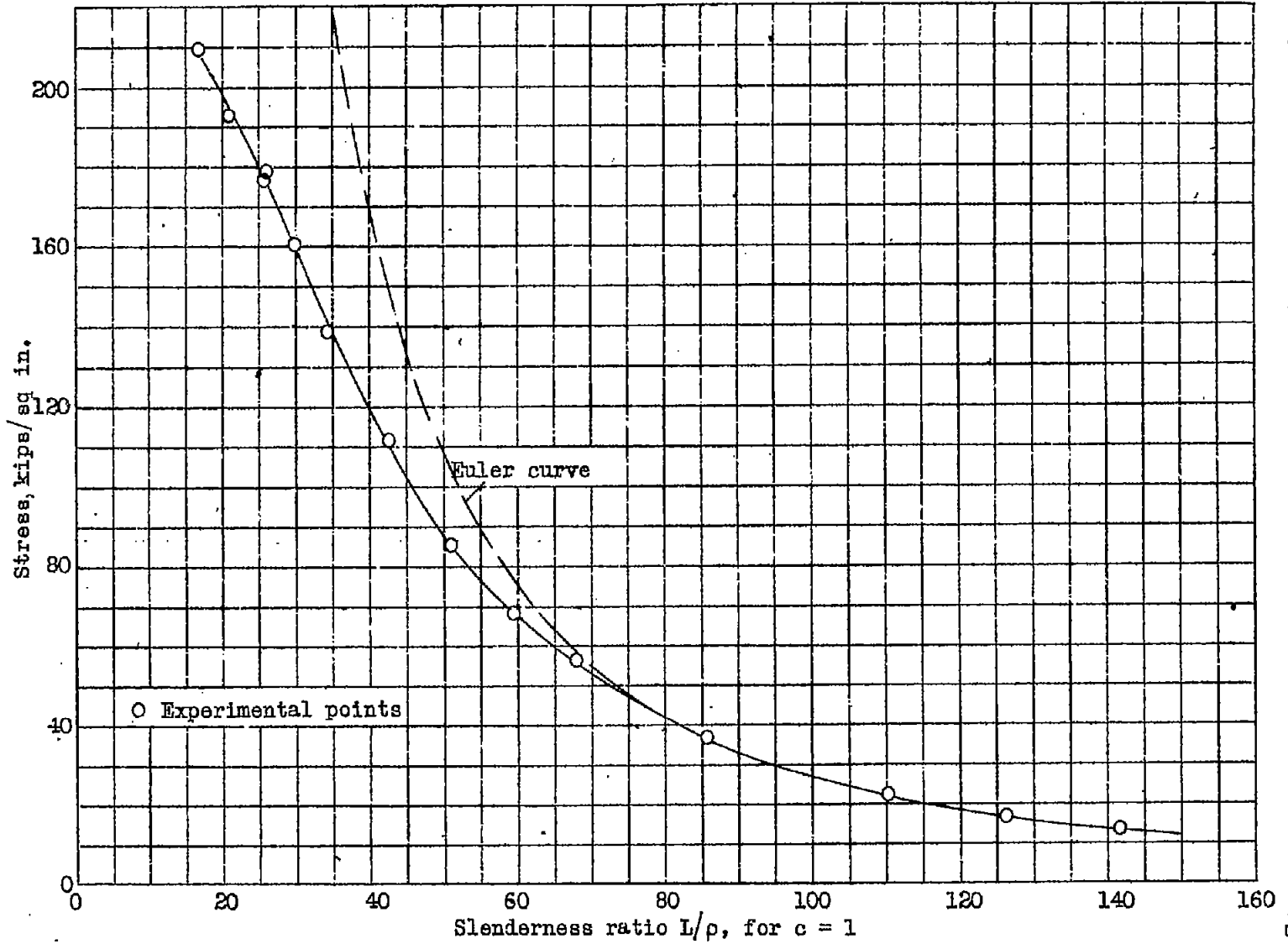

Figure 5.- Column curve for full-hard stainless steel, 0.030 inch thick, not heat-treated; loaded across grain. Series C.

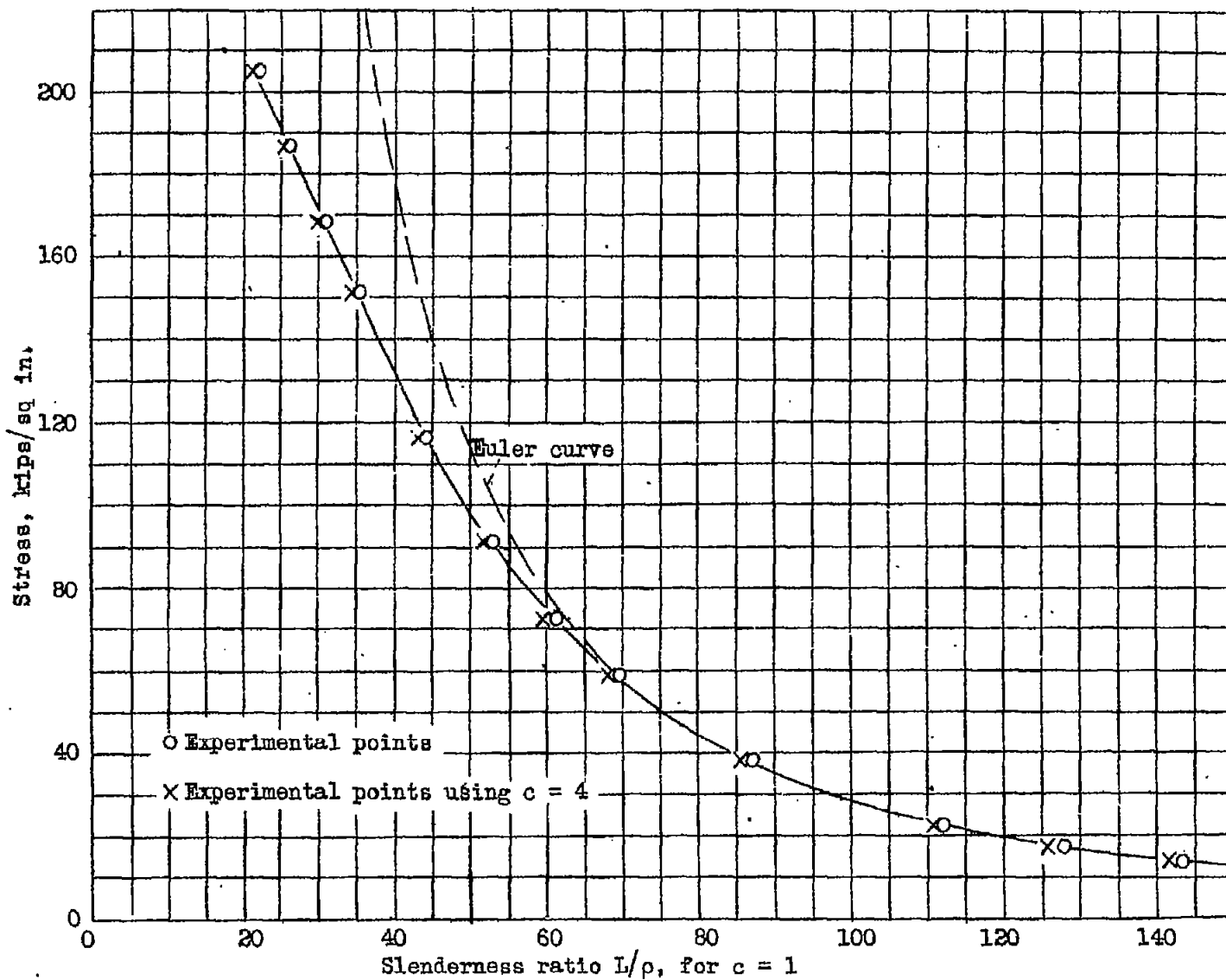

Figure 6.- Column curve for full-hard stainless steel, 0.030 inch thick, heat-treated; loaded across grain. Series D.

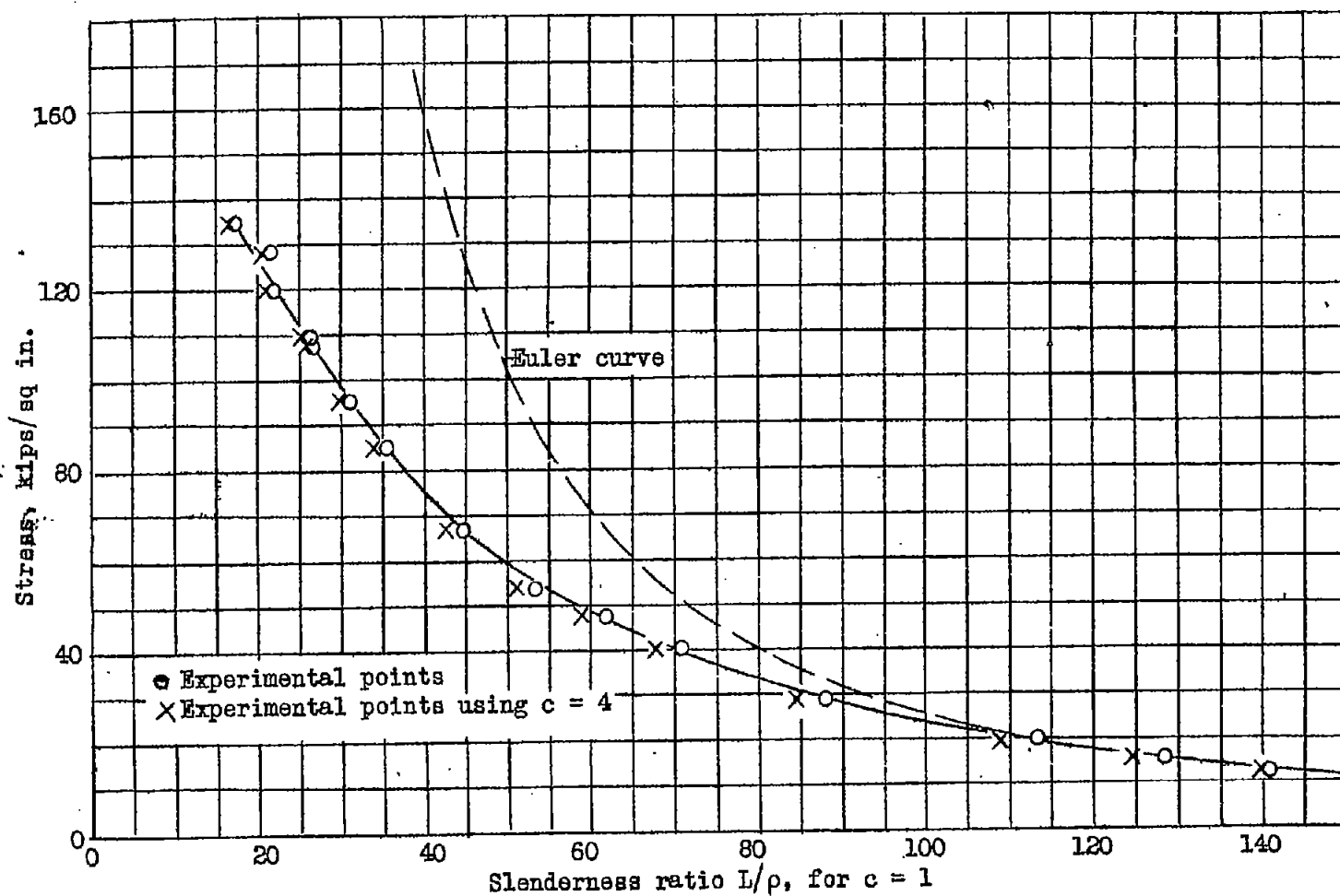

Figure 7.- Column curve for 1/2-hard stainless steel, 0.030 inch thick, not heat-treated; loaded with grain. Series E.

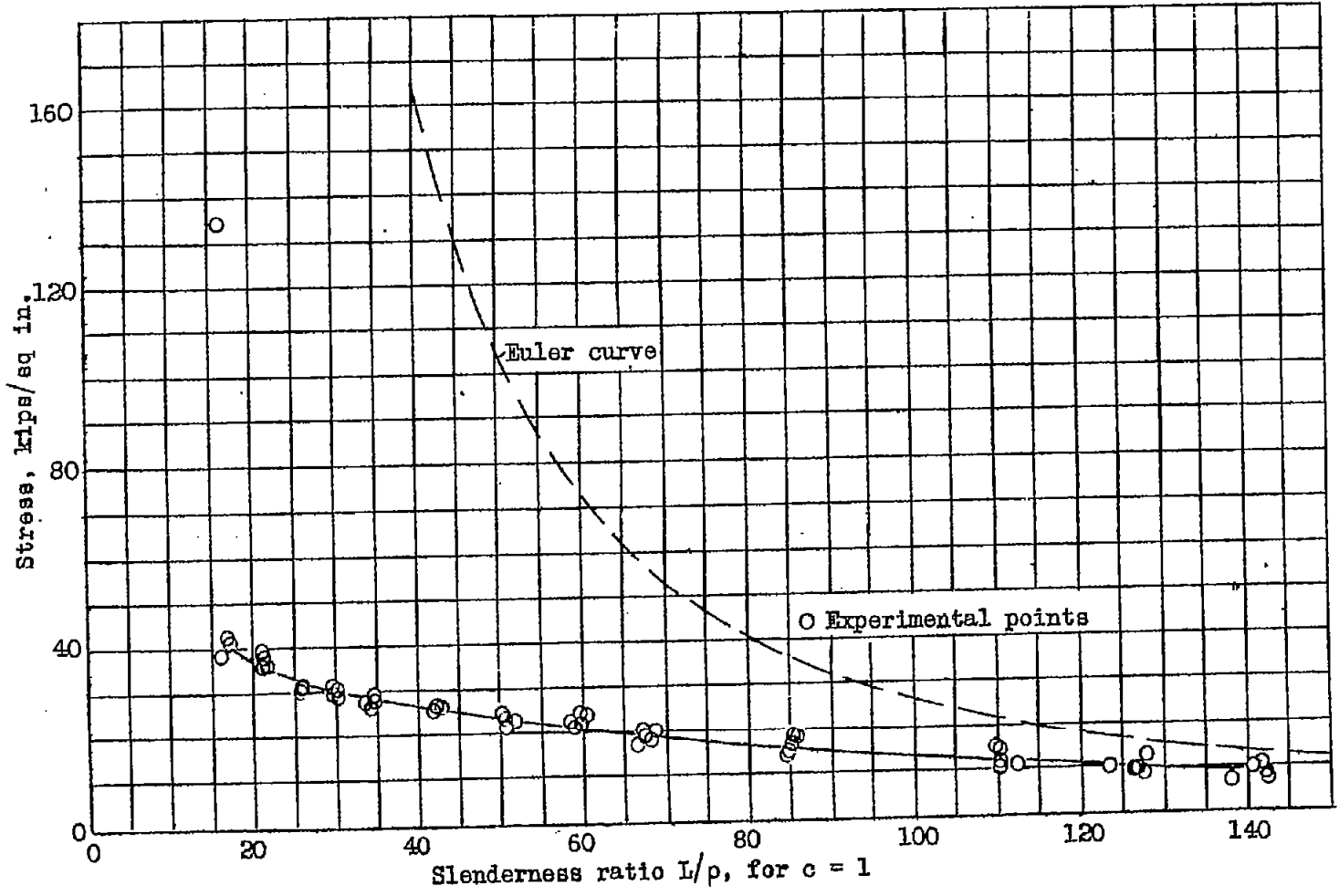

Figure 8.- Column curve for annealed stainless steel, 0.030 inch thick; loaded with grain. Series F.

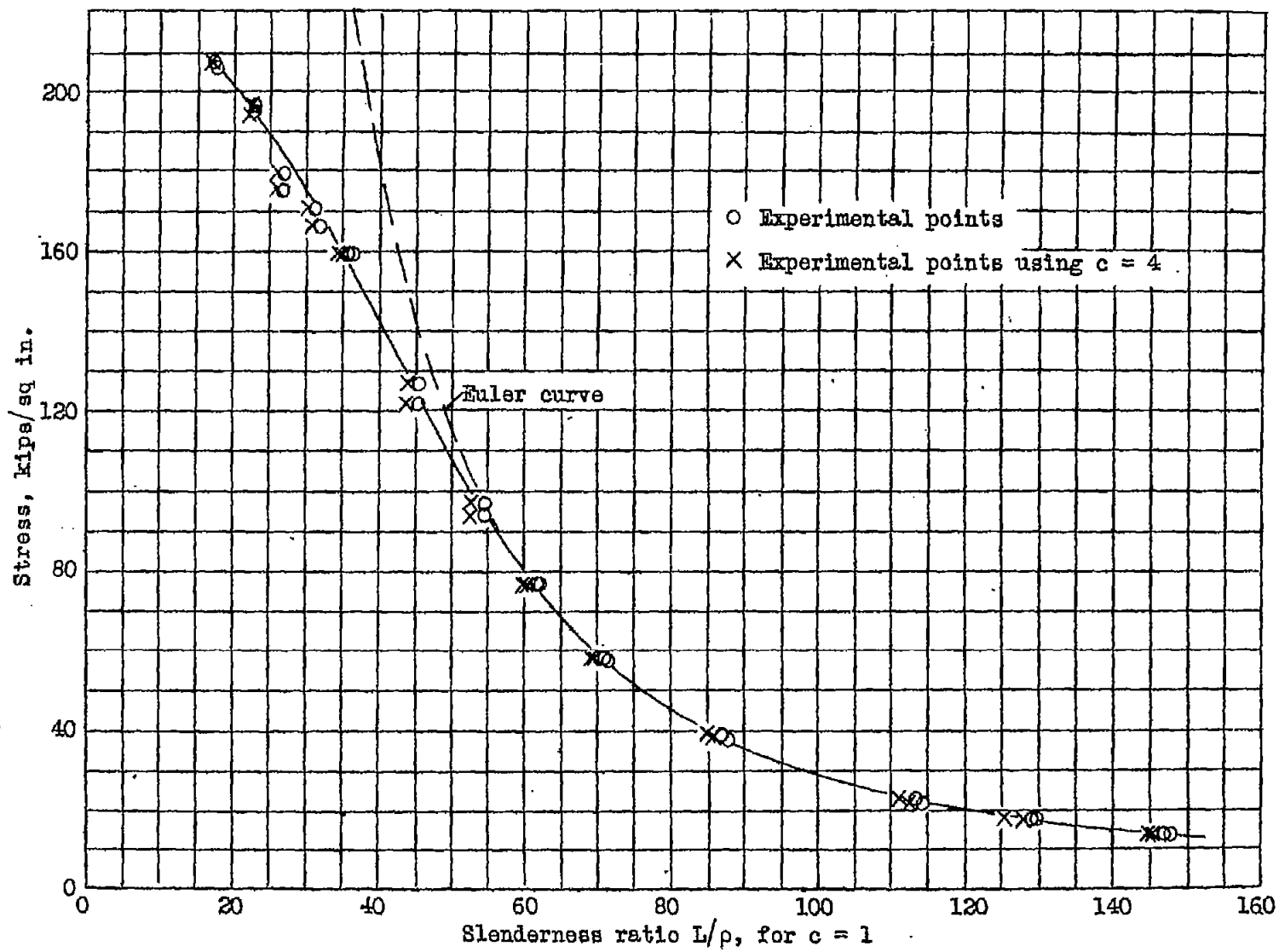

Figure 9.- Column curve for full-hard stainless "W" steel, 0.030 inch thick, heat-treated; loaded across grain. Series G.

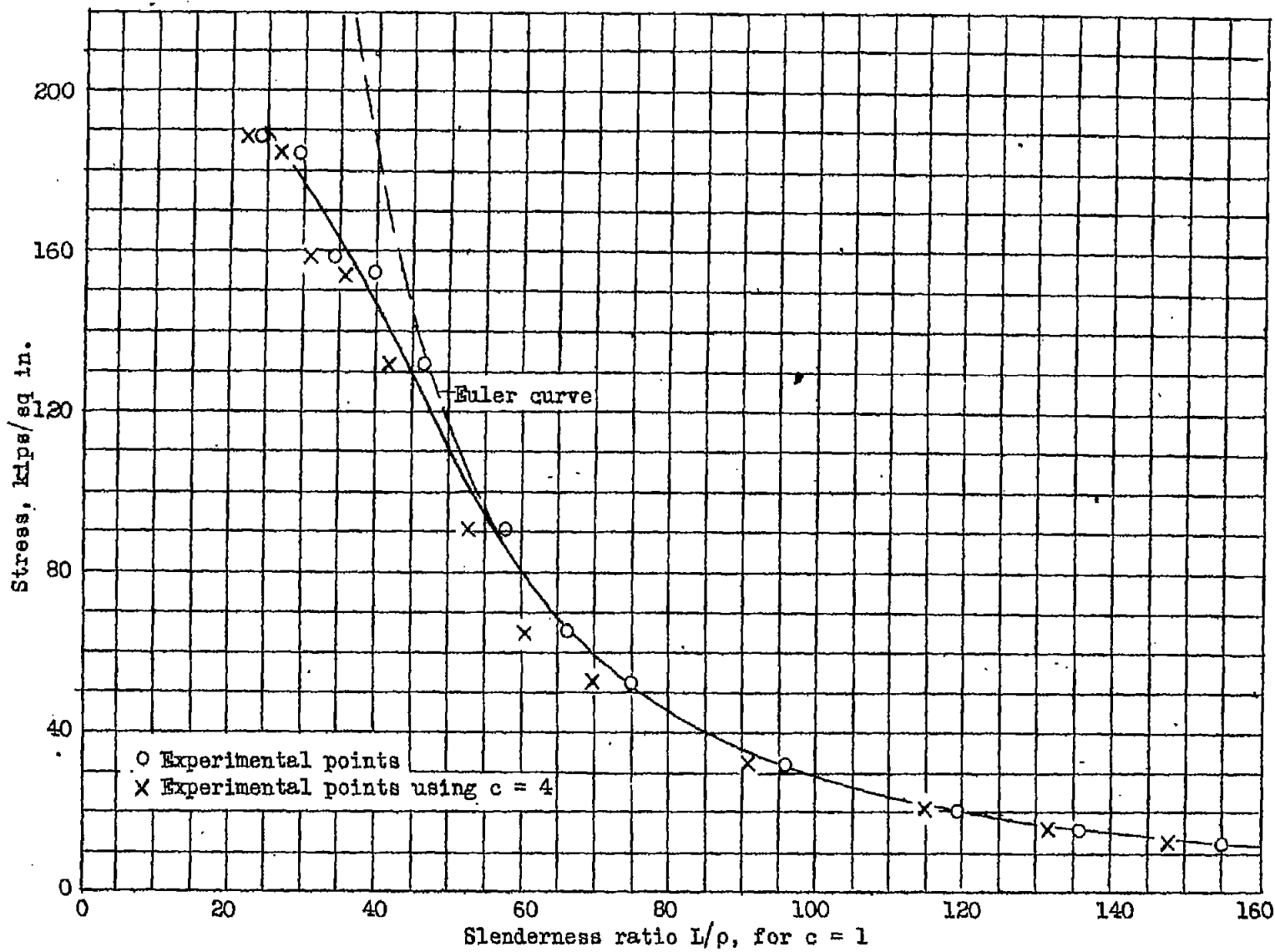

Figure 10.- Column curve for full-hard stainless "W" steel, 0.030 inch thick, heat-treated, loaded with grain. Series H.

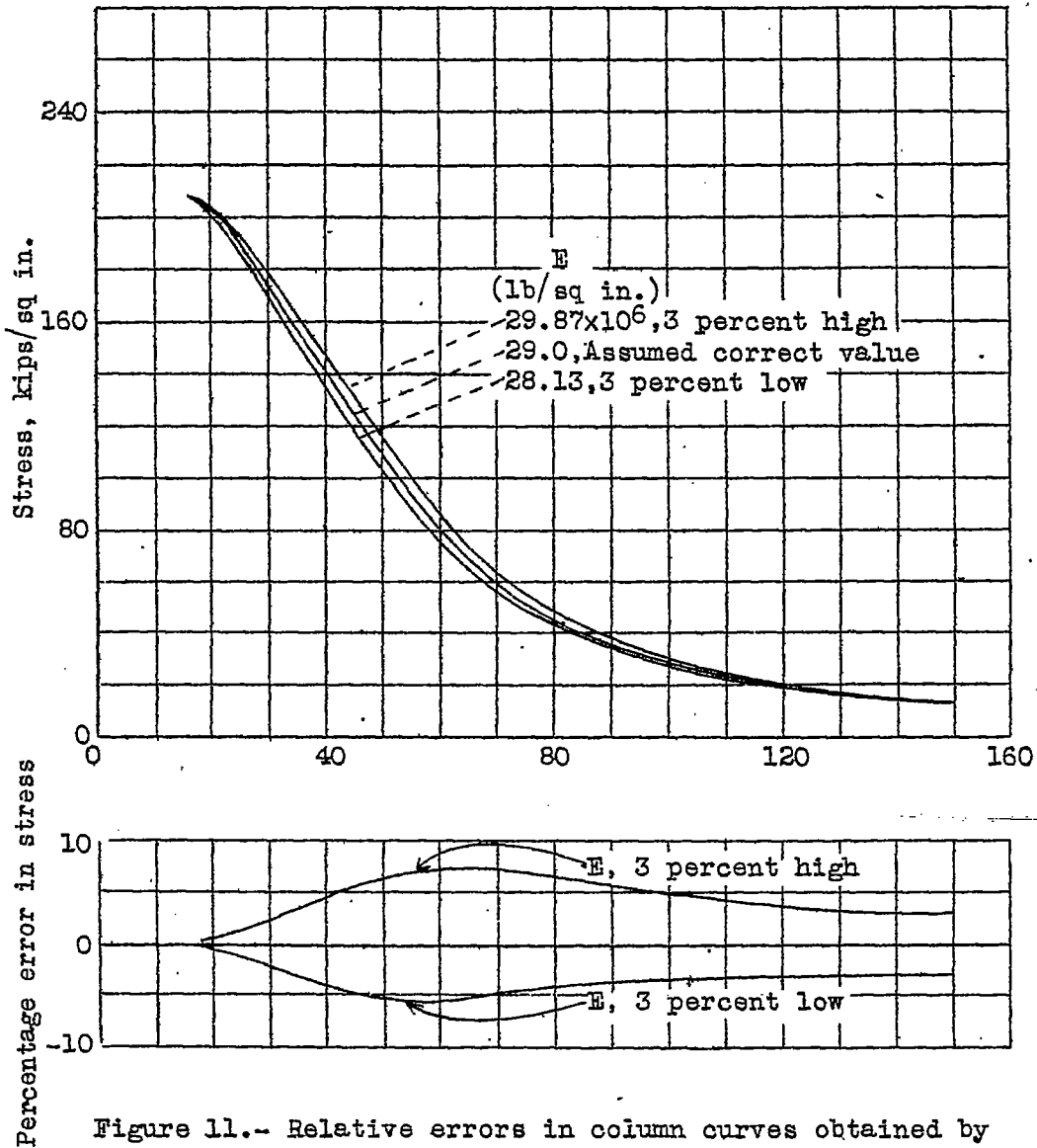

Figure 11.- Relative errors in column curves obtained by using different values of E in analyzing series G of the stainless-steel column tests.

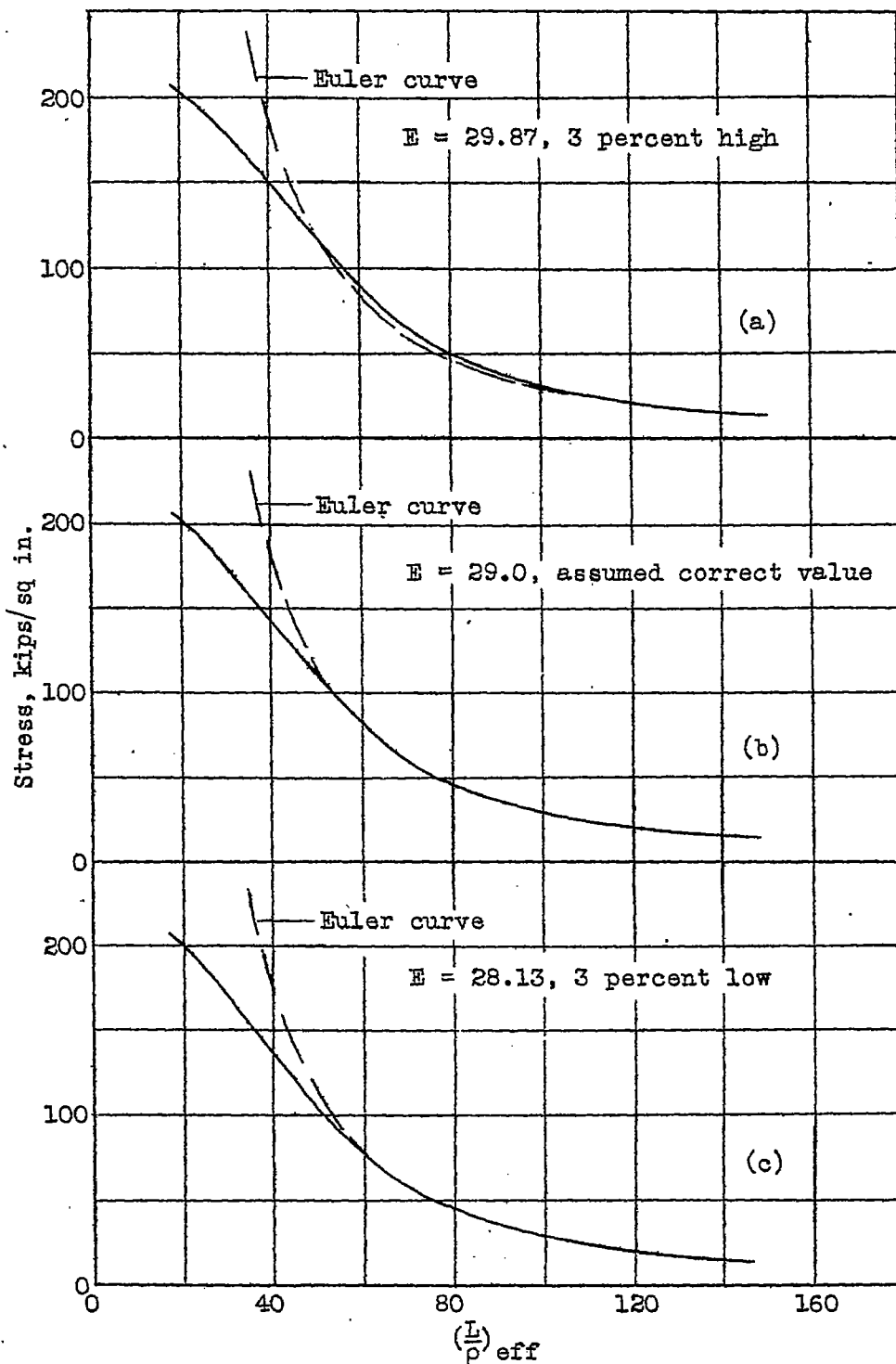

Figure 12.- Comparison of derived column curve with Euler curve for different values of E. Series G of the stainless-steel column tests.

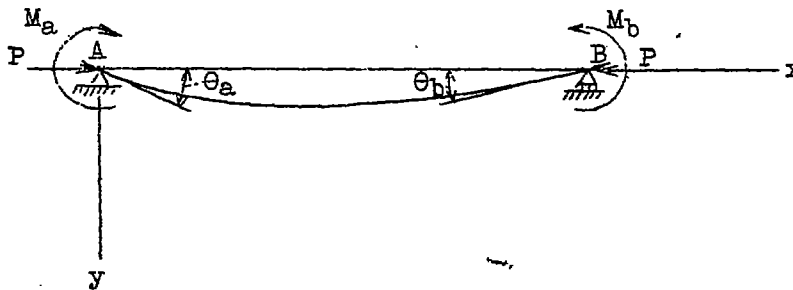

Figure 13.- Bending of a compressed bar with couples on the ends. (From reference 1.)

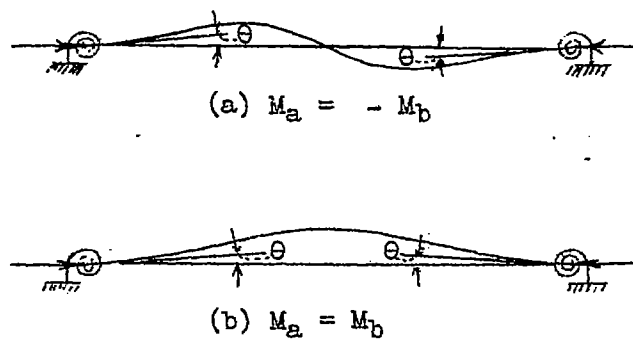

Figure 14.- Buckling configurations of a compressed bar with elastically restrained ends.

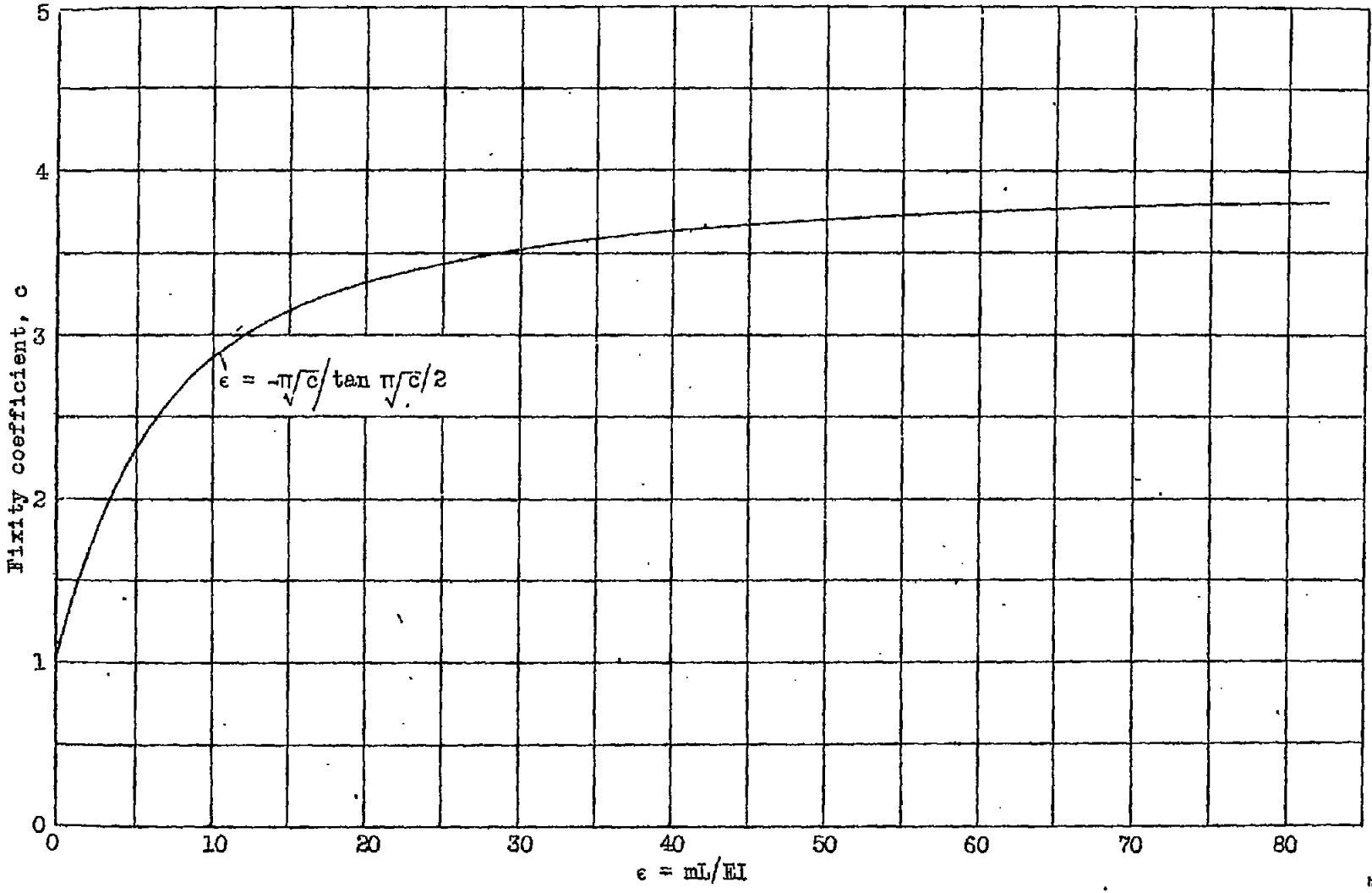

Figure 15.- Relationship of mL/EI and c for columns equally elastically restrained against rotation at each end.