

TN 1262

NACA TN No. 1262

NATIONAL ADVISORY COMMITTEE FOR AERONAUTICS

TECHNICAL NOTE

No. 1262

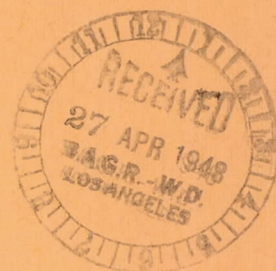

EFFECT OF VARIABLES IN WELDING TECHNIQUE ON THE STRENGTH OF
DIRECT-CURRENT METAL-ARC-WELDED JOINTS IN AIRCRAFT STEEL

II - REPEATED-STRESS TESTS OF JOINTS IN

SAE 4130 SEAMLESS STEEL TUBING

By C. B. Voldrich and E. T. Armstrong

Battelle Memorial Institute

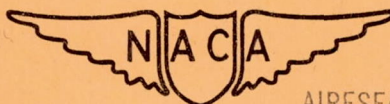

TECHNICAL LIBRARY
AIRESEARCH MANUFACTURING CO.
9851-9951 SEPULVEDA BLVD.
INGLEWOOD,
CALIFORNIA

Washington

April 1948

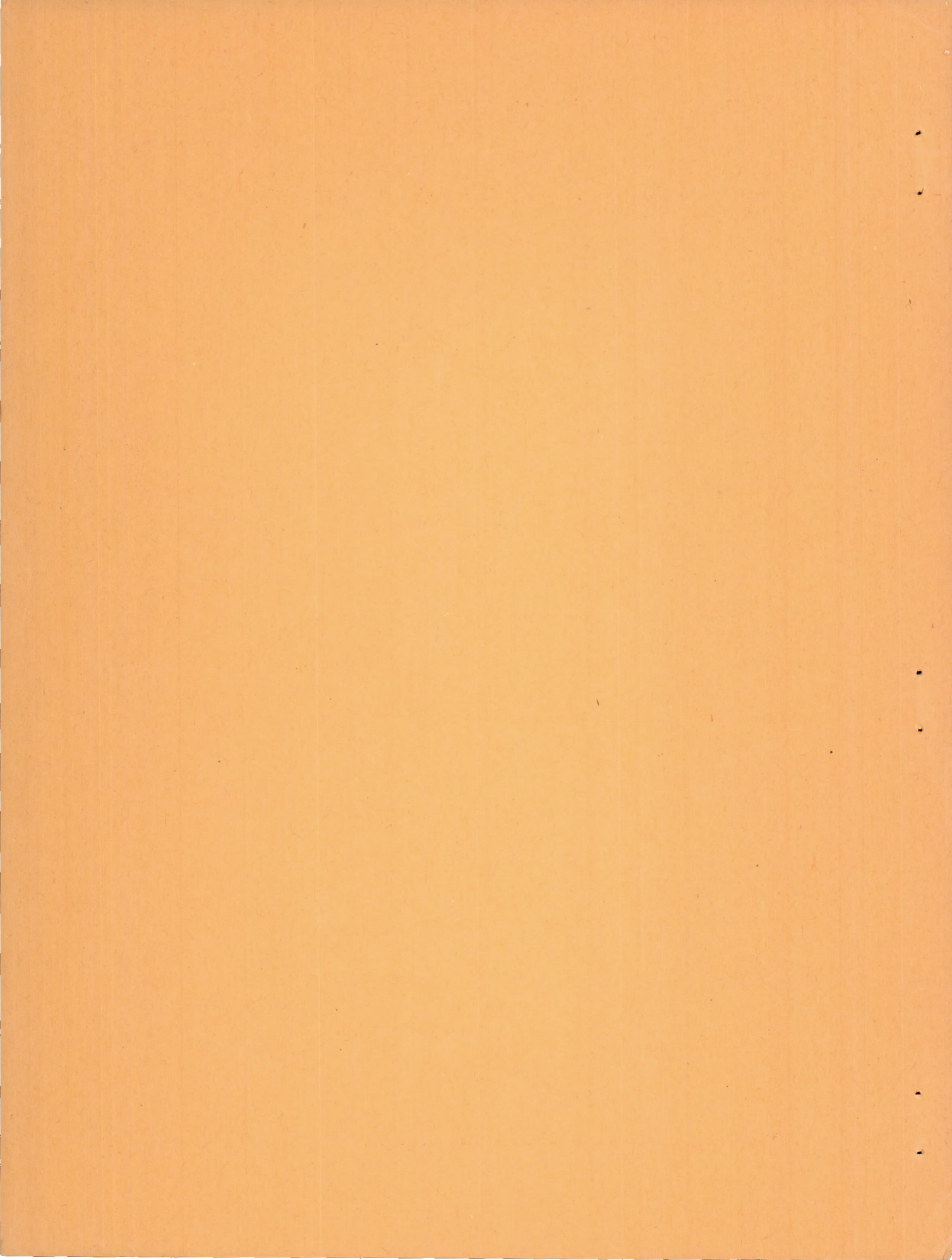

TECHNICAL NOTE NO. 1262

EFFECT OF VARIABLES IN WELDING TECHNIQUE ON THE STRENGTH OF
DIRECT-CURRENT METAL-ARC-WELDED JOINTS IN AIRCRAFT STEEL

II - REPEATED-STRESS TESTS OF JOINTS IN
SAE 4130 SEAMLESS STEEL TUBING

By C. B. Voldrich and E. T. Armstrong

SUMMARY

A series of tests were made for the purpose of establishing the effects of several variables in welding technique on the fatigue strength of arc-welded joints in SAE 4130 seamless steel tubing. The variables included type of electrode, speed of welding, current, position, amount of preheat, and other factors which in turn controlled the weld contour, penetration, and depth of the heat-affected zone. A range of joint design was also investigated.

Fatigue data showed that stress concentrations due to weld geometry were the predominating factors in determining endurance life for welds of normally acceptable aircraft quality. Previous concepts relative to the behavior of fillet and butt welds were confirmed, particularly in regard to the superiority of tapered and concave fillets and the deleterious effects of internal weld defects.

INTRODUCTION

Although static-tension and bending-fatigue tests of metal-arc-welded plate joints, as described in reference 1, brought out some effects of variations in welding technique on the strength of the joints, it was believed that more information could be obtained from fatigue tests of welded joints in aircraft tubing. With this view, a test specimen was selected which was considered related to, though not typical of, tubular aircraft joints and which lent itself to reversed-stress testing. This specimen, an SAE 4130 steel tube of 1-inch outside diameter welded perpendicularly to a 1/8-inch SAE 4130 steel plate, was loaded as a rotating cantilever beam to produce maximum alternating stresses at the circumferential fillet weld joining the tube to the plate.

In order to obtain the desired variations in welding technique, arc-welded tube-plate specimens were made under a wide variety of welding conditions with plain-carbon-steel and alloy-steel electrodes, various degrees of preheat, welding speed, current, position, and heat treatment after welding. The initial fatigue tests, however, indicated quite definitely that normal variations in arc-welding technique, which produced specimens with varying degrees of root penetration, fillet contour, weld-metal strength (carbon-steel against alloy-steel electrodes), and specimen strength (as-welded against heat-treated specimens), could not be analyzed by the rotary-bending test. The reason for this was that the stress condition at the toe of the circumferential fillet weld exerted a greater effect on the fatigue strength than all the factors arising from welding technique. With few exceptions, all fatigue failures in the tube-plate specimens occurred at the toe of the fillet weld (mostly in the tube and occasionally in the plate). Failures in the weld as a result of porosity, lack of root penetration, faulty fillet contour, and so forth, were very rare and then only partially in the weld.

When the results of the initial tube-plate tests were examined, the fatigue data available were in the form of S-N tables and graphs in which the stress was the nominal computed stress, at the toe of the fillet, resulting from cantilever loading. It was thought that the use of the nominal-stress values was misleading, because it was evident that the concentrated stress at the toe of the fillet was much higher than the computed nominal stress used for the S-N graphs. Since the actual stress at the point of failure could not be determined, it was decided that the fatigue strength of the arc-welded specimens should be presented in comparison with the fatigue strength of "ideal" specimens machined from the solid. In this way the use of the nominal stress could be avoided.

Further work on tube-plate specimens was discontinued, except for a series of tests on prestressed specimens and shot-peened specimens. Additional work was done to determine if any other form of welded tubular joint would be useful in determining the effects of welding technique on the fatigue strength.

This work was conducted at the Battelle Memorial Institute under the sponsorship and with the financial assistance of the National Advisory Committee for Aeronautics.

TESTS

The reworking of the fatigue data on the arc-welded tube-plate specimens, to introduce the comparison factor of the ideal machined specimens, necessitates that some of the data be presented without regard for chronological sequence. For clarity, the various groups of test specimens are summarized as follows and later discussed in detail:

- Series A: Ideal tube-plate specimens machined from solid bar to simulate the specimens of series B, D, E, F, and G.

- Series B: Metal-arc-welded tube-plate specimens
(1- by 0.065-in. tubes, 1/8-in. plates).
- Series C: Metal-arc-welded tube-plate specimens
(1- by 0.095-in. tubes, 1/4-in. plates).
- Series D: Arc-welded, gas-welded, and brazed tube-plate specimens, with various types of fillet.
- Series E: Metal-arc-welded tube-plate specimens with circumferential notch.
- Series F: Metal-arc-welded tube-plate specimens prestressed before fatigue test.
- Series G: Metal-arc-welded tube-plate specimens shot-peened before fatigue test.
- Series H: Metal-arc-welded tube-to-tube specimens.

PREPARATION OF SPECIMENS

Materials and Equipment

The tubing, sheet, and plate used for all tube-plate and tube-to-tube specimens were aircraft quality SAE 4130 steel with properties as given in table 1. The bar used for making the tube-plate specimens machined from the solid was SAE 4140 steel with the chemical composition shown in table 1.

The electrodes, welding rod, and brazing wire used in the tests are described in the following sections on the preparation of the several series of test specimens. The electrodes were chosen as representative of those used in aircraft production. All metal arc welding was done by the direct-current method, using a motor-generator set of the type commonly used for aircraft welding. It had been decided that remote-current-control devices (crater eliminators) were not to be used.

Series A: Ideal Tube-Plate Specimens Machined from Solid Bar

For series A, eight tube-plate specimens were machined from 2- by 2-inch SAE 4140 bar, as shown in figure 1. These specimens were identical in dimensions with metal-arc-welded specimens made of 1- by 0.065-inch seamless tubing and 1/8-inch plate, except that the fillet was fully concave and finished smooth.

The 2- by 2-inch bar was first rough forged down to about $1\frac{1}{4}$ inch round, with an upset end about 4 inches in diameter and 1 inch thick to provide for the flange. After rough machining to the approximate dimensions, the flanged tubes were normalized, and then finish machined, as shown in figure 2 (right-hand specimen). One tube-plate specimen was also prepared with a fully convex fillet for use in the tests of series D (fig. 2, left-hand specimen).

SAE 4140 steel was used for the ideal specimen because no SAE 4130 steel was available in sufficiently large size for the necessary forging and machining. The hardness of the normalized machined specimens was about 320 Vickers (a tensile strength of 150,000 psi, by conversion from hardness). The average parent-metal hardness of the SAE 4130 tubing used in the welded specimens was about 250 Vickers (120,000 psi) in the unaffected metal, and about 420 to 460 Vickers (195,000 to 215,000 psi) for the heat-affected metal adjacent to welds (no heat treatment after welding). Therefore, in the comparison of the fatigue strength of machined to welded specimens, it should be kept in mind that the tensile strength and inherent endurance limit of the most highly stressed metal (adjacent to the fillet) was sometimes greater and sometimes less for the welded than for the machined specimens, depending on the heat treatment after welding. This difference does not, however, invalidate the comparison of the fatigue data, since other factors, discussed later, were found to have considerably more effect on the fatigue behavior.

Series B: Metal-Arc-Welded Tube-Plate Specimens

The specimens of series B were made from 1- by 0.065-inch SAE 4130 seamless steel tubing and 1/8-inch SAE 4130 steel sheet, according to the recommended design illustrated in figure 3.

The welding data for this series are given in table 2 and figures 4 to 12. The three principal welding variables were type of electrode, preheat, and heat treatment after welding. The specimens were welded with the tube and plate held together in a positioning jig (fig. 13) with the tube axis approximately 30° from the horizontal. The assembly was then rotated in the jig at a speed which could be controlled by the operator during welding. No tack welds were used. The weld was made in the flat (down-hand) position, in two semicircular increments, both welded in the same direction. The resulting fillets were above average in contour (flat to slightly convex), smoothness, and consistency in dimensions. A typical specimen of the group, 568A, is shown in figure 14.

Because of distortion during welding, it was found impracticable to hold the tube absolutely perpendicular to the plate by means of the alining spindle, and the specimens were welded with the outer end of the

spindle free to move about $1/16$ inch from the perpendicular axis. The eccentricity in the welded specimen was seldom more than 0.05 inch and did not measurably affect the stresses induced in rotary bending. (See fig. 15.)

In preliminary welding trials, the tube-plate assembly was placed in the jig without insulating the plate from the steel chuck with an asbestos pad. It was found that under this condition the $1/8$ -inch sheet often cracked under the fillet weld. The cracking could be eliminated in one of three ways: (1) preheating the plate to about 200° F, (2) insulating the plate from the chuck with asbestos, or (3) using another heat of $1/8$ -inch SAE 4130 steel (no preheat or insulation required). In the preparation of all specimens for this investigation, the second method, insulation with asbestos, was used.

Prior to the rotary-bending tests, a representative specimen from each group in series B was X-rayed to show the quality of the weld. These radiographs are discussed in the section on fatigue tests. Other radiographs were also made through the tube at the weld to disclose possible cracks adjacent to the fillet; no cracks were found.

Before fatigue testing, all specimens were pressure tested at an air pressure of 100 psi and were then Magnafluxed. Aside from a few pinhole leaks, which usually occurred at the start of the second semicircular fillet, no defects were found.

Series C: Metal-Arc-Welded Tube-Plate Specimens

The specimens of series C were made in the same way as those of series B, except that 1 - by 0.095 -inch SAE 4130 seamless steel tubing and $1/4$ -inch SAE 4130 steel plate were used. The welds were also made with a greater variety of welding electrodes, which was the principal variable for this series.

With these thicknesses of tubing and plate, it was necessary to use electrodes of larger diameter ($1/8$ inch) than for series B, and consequently the series C fillet welds were larger, averaging about $7/32$ inch, with a flat to moderately convex face. Detailed welding data are given in table 3.

No radiographs were made of the series C specimens, but all were pressure tested and Magnafluxed prior to the rotary-bending test.

Series D: Welded, Brazed, and Machined Tube-Plate Specimens

The early rotary-bending test data on the metal-arc-welded tube-plate specimens of series B and C indicated that the geometry of the

fillet weld had a significant influence on the fatigue strength. In order to check this, the tube-plate specimens of series D were made with various fillet contours, and further variables were introduced to determine the effect of fillet material and heat treatment after welding. The principal variables were as follows:

1. Metal-arc-welded specimens
 - a. Small fillet
 - b. Medium-size fillet
 - (1) No heat treatment
 - (2) Annealed
 - (3) Flame softened
 - (4) Normalized
 - c. Large fillet
 - (1) Single layer
 - (2) Two layer
 - (3) Three layer
 - (4) Four layer (combination arc and gas weld)
 - d. Fillets made with 25 Cr - 20 Ni electrodes
 - e. Fillets with face ranging from fully concave to fully convex (see fig. 14)
2. Oxyacetylene welded specimens
 - a. Medium-size fillet
 - b. Large fillet (three-layer)
3. Brazed specimens
 - a. Medium-size concave fillet
 - b. Large concave fillet
4. Arc-welded specimens with 1-inch solid round bar in lieu of tube
5. Specimens machined from solid forgings, with convex and concave fillets (see fig. 2)
6. Arc-welded specimens with machined fillets
 - a. Fillet machined fully concave
 - b. Fillet machined concave at toe (tube)
7. Plate-tube-plate metal-arc-welded specimens for axial-tension-compression and axial-repeated-tension tests. (These were similar in every respect to the tube-plate specimens, except that they had a plate welded at each end of the tube to facilitate gripping in the axial fatigue machine.)

The welding data for the series D specimens are given in table 4, and data on the type of fillet are shown in figure 16.

Series E: Notched Tube-Plate Specimens

In order to obtain a quantitative indication of the degree of stress concentration existing at the toe of fillet-welded tube-plate specimens,

a group of eight rotary-bending specimens was made with a circumferential notch cut into the tube adjacent to the fillet weld, as shown in figure 17. Three specimens were also made with an austenitic-steel metal arc weld instead of the tapered gas weld used in the other eight specimens. Welding data for the notched specimens are given in table 5.

Series F: Metal-Arc-Welded Tube-Plate Specimens for Prestress Tests

In order to check the possible beneficial effect of prestressing on the fatigue strength of arc-welded tube-plate specimens, that is, the effect of mechanical stress relief at the toe of the fillet weld, a series of specimens was made as shown in figure 18. The welding procedure for these was similar to that used for the series B specimens, as indicated by the welding data in table 5.

Three groups of six specimens were prepared. The first group was tested in the as-welded condition. The second group was prestressed after welding, by loading each specimen in axial static tension beyond the yield point (approx. 85,000 to 90,000 psi). The third group was furnace annealed at 1600° F after welding, then prestressed in axial static tension beyond the yield point (approx. 45,000 to 50,000 psi).

It should be noted that the finished specimens for the rotary-bending test (after they had been prestressed, and one tube and its weld machined off) included the fillet which was deposited last. This was done in order to obtain specimens as similar as possible to the standard tube-plate specimen, with no heat effects from the opposite weld.

Series G: Metal-Arc-Welded Tube-Plate Specimens for Shot-Peening Tests

For series G a group of metal-arc-welded tube-plate specimens was prepared, similar to those used in series B, in which a part of the group was subjected to a shot-peening treatment before the rotary-bending test. The remainder of the group was tested in the as-welded condition for comparison. The welding data for series G are given in table 5, and typical specimens before and after shot-peening are shown in figure 19.

The shot-peening was done at the General Motors Corporation Research Laboratories, by arrangement with Mr. J. O. Almen. The welded specimens (no heat treatment after welding) were peened in a high-intensity stream of small shot (0.016 to 0.019-in. diam.). Small shot was chosen so that the peening action would reach the bottom of each ripple and depression in the fillet weld. The intensity of peening was such as to give 0.012-inch arc height on the standard General Motors shot-peening test strip. Uniform peening of the weld was obtained by mounting the specimen on a rotating table. The remaining areas were peened by hand.

Series H: Metal-Arc-Welded Tube-to-Tube Specimens

Six tubular welded specimens were made from 1- by 0.065-inch SAE 4130 seamless steel tubing as shown in figures 20 and 21 for reversed-stress testing. The purpose of this test of series H was to investigate the possibility that welded tubular joints would be less susceptible to stress-concentration effects than the tube-plate joint previously investigated.

The joints were welded with the sequence shown in figure 20, and with other welding conditions as shown in table 5. The specimens were Magnafluxed after welding, and no cracks were detected.

FATIGUE-TEST METHODS

Rotary-Bending Test

The tube-plate specimens of series A, B, C, D, E, F, and G were tested in the rotary-bending machine shown in figure 22. The plate, previously machined from a 4- by 4-inch square to $3\frac{3}{8}$ inches in diameter, was gripped in the chuck, with the specimen so centered as to give zero run-out at point A in figure 15. In this way the possibility of unequal stress distribution owing to specimen eccentricity was avoided.

The load was obtained by tightening the calibrated spring to the desired amount (measured by spring deflection). The speed of the testing machine was 2400 rpm, which gave 2400 cycles per minute of completely reversed stress. The machine was stopped automatically by a limit switch if the specimen broke or if the deflection of the tube exceeded a predetermined amount.

Axial Tension-Compression Test

The plate-tube-plate specimens of series D were loaded in an axial-tension-compression fatigue testing machine. The end plates were gripped in chucks welded to 12-inch lengths of $1\frac{1}{2}$ -inch tubing, which in turn were held in the grips of the testing machine. This gave the degree of flexibility necessary to obtain uniform stress distribution. The load was applied at a rate of 1200 cycles per minute.

A similar arrangement was used for repeated-tension test of plate-tube-plate specimens.

Reversed-Bending Test

Reversed-bending tests of the tubular "pi" specimens of series H were made in a plate-bending machine. One end of one 18-inch member was fixed, and the corresponding end of the other 18-inch member was attached to the reciprocating crank arm of the testing machine as shown in figure 23. The stress in the specimen was computed from the deflection of the loaded end. A representative specimen had previously been loaded in a static-tension machine to get the loads corresponding to given deflections. Also, the first specimen tested in the plate-bending machine was equipped with SR-4 electrical strain gages, and the maximum dynamic stresses in the long tubes, adjacent to the welds, were measured. The measured stresses corresponded within 5 percent of those computed from the deflection readings.

RESULTS OF TESTS

Series A: Ideal Tube-Plate Specimens Machined from Solid Bar

The results of rotary-bending tests on the machined tube-plate specimens with concave fillet are given in table 6 and plotted in figure 24. The graph in this figure is an S-N curve, in which the stress shown is the nominal maximum stress in the tube at the toe of the concave fillet, computed from the equation

$$S = \frac{Px}{Z}$$

where

- S nominal maximum stress, psi
- P concentrated load at end of tube, pounds
- x distance from load to toe of concave fillet, inches
- Z section modulus of the 1- by 0.065-inch tube

Method of Computing Stress Ratios for Welded Specimens

The data for the specimens of series A could have been plotted on a load-cycle scale. However, the stress-cycle scale was chosen for the basic graph because it was desired to compare all other tube-plate fatigue data with the basic graph. Since the section moduli of the welded specimens varied with the size of tube, all load data were first converted into nominal-stress values, and these were compared with the stress values for the ideal machined specimens.

The method used to convert the computed stress values into stress ratios is given in figure 25. These stress ratios were then used in all subsequent graphs to show the fatigue strength of welded tube-plate specimens in comparison with the fatigue strength of the ideal specimen.

Line ABg' in figure 25 is the S-N curve obtained from rotary-bending tests of the basic machined specimens (fig. 24). On this graph was superimposed each group of rotary-bending S-N data for welded tube-plate specimens, and those stress values on the base line ABg' were taken which correspond to the life of the individual welded specimens. For each cycle intercept, the stress in the welded specimen was compared with the stress in the ideal specimen at the same number of cycles. For example, if at 34,500 cycles the nominal stress in the welded specimen was the same as the stress in the ideal specimen (points d and d'), the stress ratio for that welded specimen was $\frac{d}{d'} = 1.0$. This value was then plotted against the number of cycles (34,500) on a separate graph for the particular series of welded specimens. Again, if at 387,900 cycles the nominal stress in the welded specimen was 5,700 psi (point f), the corresponding stress in the ideal specimen was 16,000 psi (point f'), and the stress ratio for the welded specimen was $\frac{f}{f'} = 0.36$, which was then plotted on the separate graph against 387,900, the number of cycles.

In order to permit accurate computation of the stress ratios, the graph actually used was much larger, with a closer coordinate scale than indicated in the schematic graph, figure 25.

The load-cycle curve plotted using the stress ratios computed in figure 25 is given in figure 26, which is discussed in the next section. All subsequent load-cycle graphs were plotted similarly. It should be kept in mind that the load-cycle graphs are not S-N curves, and that their value lies principally in comparing one load-cycle graph with another. On the load-cycle graphs the points for the ideal specimens would all fall on the horizontal ordinate 1.0.

Series E: Notched Tube-Plate Specimens

The rotary-bending tests of series B and C, discussed later, indicated that for the type of specimen and loading involved, a stress concentration occurs at the toe of the fillet of such magnitude that the effects of other factors, such as weld smoothness, penetration, extent of heat-affected zone, and the like, are obscured. In order to determine the approximate degree of magnitude of the stress concentration, a rotary-bending test was made of tube-plate specimens which had a notch cut circumferentially in the tube, at a section $\frac{3}{4}$ inch away from the plate surface (fig. 17). The relative life of the notched specimens, with nominal stresses in the notched section comparable with those used in the series B and C tests, would indicate the severity of the stress concentration at the fillet weld.

The details for all notched specimens tested are given in figure 26, which also shows the fatigue strength expressed as a ratio of the strength of the notched specimens to that of ideal machined specimens. It is emphasized that the ratios given in figure 26 are for stresses in the reduced tube section at the notch. At the toe of the fillet the bending moment is higher, but the area of the tube section is about double that at the notch so, for a given load, the unit stress at the fillet is about 40 percent less than at the notch.

The test indicated by point (1) in figure 26 should be noted, in which the notched specimen failed at the toe of the fillet (3,792,000 cycles at 0.65 fatigue ratio) even though the computed stress at the notch was obviously higher. This would indicate that the endurance limit for the section at the toe of the fillet was lower than for the notched section. A photograph of this specimen is shown in figure 27.

The solid line m in figure 26 represents the approximate curve of strength ratio against cycles for the specimens with a 0.030-inch notch. This curve has been superimposed on all subsequent rotary-bending-test graphs, as a broken line designated m . It is useful in the graphs as a datum line, to facilitate comparison of various sets of values and also to indicate the level of fatigue strength of the welded specimens in comparison with notched specimens.

Series B: Metal-Arc-Welded Tube-Plate Specimens
(1- by 0.065-In. Tube, 1/8-In. Plate)

The rotary-bending test data for the several groups of specimens in series B are summarized in figure 28. Detailed data for the several groups are also given in table 7 and figures 4 to 12.

It will be remembered that the welded specimens of series B were in nine groups, the principal variables being type of electrode, preheat, and heat treatment after welding. The original plan had been to compare the fatigue data for the various groups, to study the influence of the principal variables, and then to extend the tests to include other welding-technique factors. It developed, however, that regardless of the welding variables, practically all the specimens failed in the tube at the toe of the fillet weld, and the life at various loads did not reflect any particular effect of welding technique. This can be seen from a study of the individual graphs for fatigue tests of various groups of tube-plate specimens in series B (figs. 4 to 12) and of the summary graph (fig. 28).

The consistent failure at the toe of the fillet weld (characteristic fracture shown in fig. 27) was not entirely unexpected, since all the fillet welds in series B were of a quality representing good welding

technique and since it had been recognized that a stress concentration at the toe of the fillet would cause a stress in the tube considerably higher than the computed, or nominal stress. (See table 7). No failures occurred in the weld which might be associated with either of the two craters or starting points in each circumferential fillet weld.

It had not been anticipated that the life of the specimens, at the various loads used, would be so short or that the specimens would fail at such low loads. After the first few groups had been tested, a representative unbroken specimen from these groups and one from each of the yet untested groups were radiographed through the tube, and then sectioned for macroscopic and microscopic inspection. This procedure was made to check the possible existence of minute cracks which might be responsible for the low fatigue strength and consistent localization of failure; however, no such cracks were found. Previous Magnaflux and air-pressure tests also had not disclosed any cracks or similar defects.

Two sets of radiographs through the weld and plate of series B specimens are shown in figures 29 and 30. These indicate that the welds were of good quality, with no discernible crater defects. The welds made with plain-carbon-steel electrodes (fig. 29) show some lack of root penetration, but this had no influence on the fatigue strength of the specimens.

The broad conclusions that may be drawn from the results of the rotary-bending tests of the series B specimens are:

- (1) The long-time (1,000,000-cycle) fatigue strength of the welded specimens was about one-fourth to one-half that of the ideal machined specimens.
- (2) The short-time (10,000- to 50,000-cycle) fatigue strength was about equal to that of the ideal specimens.
- (3) The fatigue strength of the welded specimens was less than that of similar specimens with a 0.030-inch circumferential notch in the tube, except at very high loads causing early failure.
- (4) Variables such as type of electrode, preheat, heat treatment, and degree of root penetration (within the limits indicated in fig. 29) had no appreciable effect on the fatigue strength of the welded specimens.
- (5) The results indicate quite definitely that most of the ordinary effects of welding technique were obscured by the stress concentration at the toe of the fillet weld. This was further confirmed by spot checks on trial specimens with extremely poor welds, for example, no fusion to portions of the tube, and unsatisfactory lumps and craters. Most of these specimens also failed in the tube at the toe of the fillet weld, rather than in the substandard weld.

Series C: Metal-Arc-Welded Tube-Plate Specimens
(1- by 0.095-In. Tube, 1/4-In. Plate)

Since practically all the failures in the series B specimens were in the 0.065-inch tube, it was decided to strengthen the tube by increasing its wall thickness and thus put more stress into, and induce fracture in, the fillet weld. The specimens of series C were made with 1- by 0.095-inch tubing, and the plate thickness was increased from 1/8 to 1/4 inch. With these thicknesses of plate and tubing, it was also necessary to use an electrode of larger diameter, and the resulting fillets were about 7/32 inch in size (as compared with 5/32 inch for series B).

In addition to data on the effect of increased plate and tube thickness, the tests of series C were designed also to give information on the influence of 10 various types of electrode on fatigue strength. The test results are given in table 8 and the summary graph, figure 31. No attempt was made to plot a separate graph for each electrode used, since it was evident that the type of electrode used had no influence on the fatigue strength.

Although the fillet welds in series C were larger than those in series B, it had been expected that at least a few specimens with the thicker tube would fail in the weld. However, the location of failure was, as before, in the tube at the toe of the fillet weld. There was, nevertheless, a significant difference between the fatigue strength of series B and series C. This can be seen by a comparison of the graphs, figures 28 and 31, and is further illustrated by the zone diagram, figure 32. The life of the specimens of series C was consistently longer for a given load than that of the specimens of series B with the thinner tubes. The endurance limit for series C is also somewhat greater, but the data in this load region are insufficient in quantity and consistency for accurate analysis of the relative endurance limits.

Series D: Welded, Brazed, and Machined Tube-Plate Specimens

The tests of welded tube-plate specimens of series B and C indicated that while the effects of the welding techniques used, that is, root penetration, type of weld metal, preheat, and heat treatment after welding, had no influence on the fatigue strength and location of failure, there was a size or geometry effect. In order to check this, the tube-plate specimens of series D were made. These included specimens with fillets of various size and contour, made by the metal-arc, oxyacetylene-welding, and oxyacetylene-brazing methods. The variables have been previously described in the section PREPARATION OF SPECIMENS, and are tabulated and illustrated in figure 16. Most of the specimens were tested in rotary bending, but a few specimens were also tested in axial tension and compression and repeated tension to check the possible difference in fatigue strength that might be obtained with axial instead of bending loading.

All the tests tabulated in figure 16 were made at loads which would produce about the same nominal tube stress (that is, 21,000 to 26,000 psi). The graph in figure 16 compares the respective life of all specimens at that nominal stress. The one exception was test 472H on tube-bar specimens, in which the load was the same as for 1- by 0.065-inch tube specimens, with a correspondingly lower nominal stress. For information, the computed stresses are given in table 9. This table also gives data for the repeated-tension tests, which could not be plotted in direct comparison with the other tests because of the difference in the mean stress.

None of the tests in series D gave a true indication of the strength of the weld or fillet itself, but the results indicate quite clearly the effect of various types of fillet on the strength of the adjacent tube section. Specimens with long tapered fillets (tests 480D and 507), and with fully concave fillets (tests 524, 480C2, and 480E) were among the strongest in rotary bending. Specimens with flat or convex fillets had a shorter life. Size of fillet alone apparently was not a factor in determining the fatigue life of the joint, although there is a slight indication that the large fillets were better than the small ones.

Heat treatment or stress relief was apparently less influential than the degree of stress concentration resulting from weld geometry. Annealed (test 483) and flame-softened (test 480A) specimens were no stronger than normalized specimens (test 472G) or the as-welded or normalized specimens of series B. This would indicate that the stress-concentration effect was not appreciably reduced by softening or stress relieving of the tube at the toe of the fillet weld.

Test 472H, in which a solid bar was substituted for the tube, was made to determine whether, with a section of maximum strength adjacent to the weld fillet, failure could be induced in the weld. The two bar specimens were tested with the same load as the 0.065-inch tube specimens, and thus the stress in the weld and the plate were approximately the same as in the standard specimen, although the stress in the solid bar was very low (see table 9). Both bar specimens failed in the plate at the toe of the fillet, indicating that a secondary stress concentration existed at that point. It is possible that by increasing the thickness of the plate, and using a solid bar or a very thick tube, failure in the welded fillet could be induced; this, however, entails such marked changes in welding technique, heat effects, degree of penetration, and other factors that such a specimen would only remotely represent conditions found in tubular aircraft joints. Tests of such specimens were therefore not considered.

Another indication that the strength of the fillet material is of secondary importance was obtained from specimens of tests 480EF and 480E, which were made with the concave brazed fillets. The life of these specimens was remarkably long. The small-brazed-fillet specimen failed in the bond between fillet and plate at about 100,000 cycles, which is

equivalent to the best single-layer arc-welded concave fillet and better than normal arc- or gas-welded fillets. The large-concave-brazed-fillet specimen failed after about 500,000 cycles, which is equivalent to the tapered fillets made by both arc- and gas-welding methods. It has been suggested that the long life of the brazed specimens is the result of (1) the smooth, concave contour, (2) the absolute freedom of undercutting, and (3) the relatively low modulus of elasticity of the brazing metal. All three factors conceivably reduce the stress concentration at the toe of the fillet.

Two "artificial" tube-plate specimens, machined from solid forgings (see fig. 2), were made for test in series D. These were in addition to the concave-fillet machined specimens of series A. The artificial specimen with convex fillet, test 480C1, failed at about the same life as the concave-fillet specimen of series A tested at the same load. The artificial specimen with the concave fillet, test 480C2, failed at a much longer life than similar series A specimens. The reason for this could not be determined, but it is probably the result of better surface finish and fillet contour in the specimen of test 480C2, as compared with the other concave-fillet machined specimens.

It is interesting to note that the specimen of test 472D, with a single arc-welded fillet and a three-layer gas-welded overlay, failed at the rather sharp angle between arc and gas weld. Although the net cross section at this point was at least twice that of the 0.065-inch tube, the stress concentration at the weld junction was sufficient to cause failure.

Tests of arc-welded specimens with the fillets machined concave, or machined at the root to remove possible sharp undercutting (tests X and Y), provided no significant data.

Tests of plate-tube-plate specimens in axial tension and compression were made with approximately the same maximum stress, in tension and compression, as that which occurred in the rotary-bending tests of other specimens in series D. Two such specimens were tested (test 479A) and failed in the tube at the toe of the arc-welded fillet at 9,900 and 16,700 cycles. These data are plotted in figure 16 and show that the life of the axial-tension-compression specimens was no longer than the life of rotary-bending specimens made with the same size of tubing, plate, and fillet weld. It may be assumed, therefore, that the stress-concentration factor is of the same order for both types of specimen and methods of loading. Photographs of the fractures in the axial-tension-compression specimens are shown in figures 33 and 34.

Tests were also made of two plate-tube-plate specimens in axial repeated tension. These specimens (test 479B) were stressed to the same maximum tension as the rotary-bending specimens and the axial-tension-compression specimens, but the minimum load was a tension of about 1,000 psi. The stress range for these specimens was therefore only half

that of the first two types, as indicated in table 9. By halving the stress range, the life of the specimens was increased from about 13,000 cycles to about 94,000 cycles. This life, however, was still below that of the notched tube specimens of series E at a comparable range of stress, and approximately equal to that of specimens in series B, which were welded in exactly the same way. These specimens failed in the plate at the toe of the fillet weld, as shown in figure 35.

Figure 36 shows the data from series D in conjunction with the reference curve for notched tube-plate specimens, and the lower-limit lines for the rotary-bending tests of series B and C. In this figure, the results of axial-tension-compression tests are also shown.

Series F: Metal-Arc-Welded Tube-Plate Specimens for Prestress Tests

In the early work with welded tube-plate specimens two specimens were made similar in every respect to the specimens of series B, except that the tubes were welded to both sides of the plate in order that the specimens might be tested in axial tension and the static-tension strength of the fillet-welded joint determined. The ultimate tensile strength of the as-welded specimens was 105,800 and 112,000 psi, which is about equivalent to the strength of 1- by 0.065-inch SAE 4130 tubes with a square welded butt joint. The first specimen failed in the tube at the toe of the fillet and the second in the tube 3 inches away from the fillet.

These results indicated that while a stress concentration no doubt existed at the toe of the fillet at the start of static-tension loading, it was reduced by local yielding of the weld metal (because the weld metal is softer than the adjacent heat-affected zone) during the first stages of loading, and consequently the tensile strength was not noticeably affected.

It was suggested that a mechanical stress relief, or reduction of local residual stresses, at the toe of the fillet weld in rotary-bending specimens might increase their fatigue life. A series of specimens was therefore prepared as shown in figure 18, which were loaded in axial static tension beyond the yield point of the tubing to obtain the same effect at the toe of the fillet weld that was obtained in the static-tension test. The prestressed specimens were in two groups: prestressed in the as-welded condition and prestressed after annealing. An additional set of specimens was tested in the as-welded, unstressed condition.

The results of the tests are given in table 11 and plotted in figure 37. This graph indicates that prestressing had no effect on the fatigue strength of as-welded specimens and that the annealed prestressed specimens (annealed so as to reduce the hardness in the heat-affected zone and thus obtain plastic flow) had a significantly lower fatigue strength than the as-welded specimens. All specimens failed in the tube at the toe of the fillet weld.

It is evident that the stress concentration at the toe of the fillet weld is not influenced by local residual stresses which may be readjusted or eliminated by plastic flow during prestressing in axial tension. Rather, the stress concentration seems to be principally a geometrical effect which is much stronger than other factors involved. (See, for example, the tests of series D.)

The fact that the annealed prestressed specimens had a much lower fatigue strength does not conflict with previous statements that heat treatment after welding had little effect on the rotary-bending fatigue strength of tube-plate specimens. The annealed prestressed specimens had a very low yield strength, the tensile strength was undoubtedly low, and possibly the wall thickness of the tubes was reduced during prestressing, all of which would contribute to the lowered fatigue strength.

In the previous tests of series B and D, the heat treatment was, with one exception, a quench-and-draw, stress-relief, normalizing treatment or a manual flame-softening treatment, and in all these cases the fatigue strength seemed to be less affected by the heat treatment than by the geometry of the weld section.

Series G: Metal-Arc-Welded Tube-Plate Specimens for Shot-Peening Tests

A group of tube-plate specimens was welded, similar to those of series B, and sent to the General Motors Corporation Research Laboratories for shot-peening treatment. (Details are given in section PREPARATION OF SPECIMENS.) The purpose of this experiment was to investigate the effect of shot-peening in (a) relieving residual surface stresses in and adjacent to the welded zone and (b) setting up surface compression stresses which would raise the fatigue strength of the specimens.

In addition to the 18 specimens which were shot-peened, 6 were tested in the as-welded condition for comparison. The results of rotary-bending tests on all specimens are given in table 12 and are plotted in figure 38. By reference to the graph, it can be seen that the lower limit of the fatigue-strength zone for the shot-peened specimens coincides with the curve for the unpeened control specimens. The fatigue strength of the shot-peened specimens was also higher than the average for specimens of series B (similar in dimensions and welding technique, but not shot-peened). Also, six of the shot-peened specimens had fatigue strengths above that of the notched specimens (line mm, fig. 38). This is an improvement over the results of previous tests, in which the fatigue strength of arc-welded tube-plate specimens was rarely higher than the datum line mm.

It is interesting that the points for the peened specimens fall on two separate lines: the lower which coincides with that for the unwelded control specimens and indicates no improvement with shot-peening; and the upper, which indicates a marked improvement. It is possible that the shot-peening treatment may not have been uniform for all specimens, or

that those on the lower line had toe-of-weld stress-raisers of a character or magnitude which were not reduced by the peening treatment used.

Regardless of the treatment used, all specimens failed in the tube at the toe of the fillet weld. This indicates that the stress concentration resulting from the geometry of the weld section was still the primary factor influencing fatigue strength.

While more test data would be desirable, it may be concluded that the shot-peening treatment produced a noticeable improvement in the fatigue strength, although not to the degree necessary to cause occasional failure in the weld. The specimens still had an appreciably lower fatigue strength than the ideal specimens (for example, about three-fourth strength at 1,000,000 cycles, for the best shot-peened specimens).

Series H: Metal-Arc-Welded Tube-to-Tube Specimens

As a part of the investigation of various types of treatment and specimen design to find a test specimen which could be used for a study of the effects of welding techniques, the tubular pi specimens were tested. (See figs. 20 and 21.)

The fatigue test was a reversed-bending test, in which the maximum stress was obtained in the tubes adjacent to the weld. The results of tests of five specimens are given in table 13. All the specimens failed in the tube at the toe of the weld as shown in figure 39.

At a computed maximum stress of 10,000 psi the life of the three pi specimens for which cycle data are available was somewhat higher (138,000 to 369,000 cycles) than for similarly welded tube-plate specimens (65,000 to 154,000 cycles). Too much significance cannot be attached to this difference in the number of cycles to failure, because the number of specimens in each group is small. Nevertheless, it can be expected that the fatigue strength of the tube-to-tube specimens will be higher, because (1) the maximum stress in the pi specimens occurred only on two diametrically opposed surfaces, and (2) the toe of the weld in the pi specimens did not lie in a plane perpendicular to the axis of the tube, as in the tube-plate specimens. For these reasons, the stress-concentration effect in the pi specimens may not be so great.

The results indicated, however, that the pi specimen would not be suitable for tests of the effects of welding technique, because even with the more favorable characteristics of the tube-to-tube joint, the principal influence on fatigue strength was still the stress concentration at the toe of the fillet weld.

DISCUSSION OF RESULTS

Effect of Stress Concentration

The severity of the stress concentration induced by the geometry of the fillet welds is modified by gradual transitions of the fillet to the tube section. This has been demonstrated by the improvement in fatigue life of multiple-layer and concave fillets, compared with normal fillet-weld contour. The stress concentration is measurably reduced when tube-to-tube connections are used instead of the tube-plate specimen. Reference to published experimental data shows that variations in stress concentration may also be observed as the plane of loading is varied with tube-to-tube connections. (See references 2 and 3.) This has the effect of changing the joint geometry from the fillet-welded type to a saddle or butt-joint type, and the increase in fatigue life is not unexpected.

It is believed that in thin-wall sections the weld-joint geometry alone produces an unusually high stress concentration, and that other factors (surface roughness, decarburization, etc.) contribute to the reduction in fatigue strength.

Effect of Thickness of Section

It is evident from the difference in the position of the scatter bands shown in figure 32 that the size of the weld and thickness of tubing is of some importance in affecting the fatigue strength of the fillet-welded joints. While the ratio of fillet size to tube thickness was about the same for both series B and series C specimens, the latter, with larger fillets and thicker tubes, had the higher fatigue strength. This suggests that the effect of the discontinuity in the wall of the tube caused by the presence of the fillet becomes increasingly serious as the tube wall thickness decreases. However, variations in the size of the fillet, within reasonable limits, seem to exert only slight effects on the fatigue properties of the joints.

Effect of Prestressing

The rotary-bending tests of tension-prestressed specimens indicated that this treatment, which may have removed residual stresses at the joint, was not effective in improving the fatigue strength. It could be inferred, therefore, that the geometry of the joint, rather than the presence of local residual stresses, was the governing factor in the fatigue behavior of the joint.

On the other hand, local prestressing by shot-peening seemed to work some improvement in fatigue strength. Whether this improvement is attributable to the effect of compressive stress or the effect of cold-

working of the surface is not entirely clear. It seems probable that the reduction in the maximum effective tensile stress owing to the induced compressive stress is the principal cause of increased fatigue life.

Effect of Surface Decarburization

No tests were made to show the effect on fatigue strength of the decarburized surface which is normally found in commercial SAE 4130 tubing and sheet. Recent tests at Battelle Institute of flash-welded SAE 4130 steel sheet have shown that decarburization is a factor of considerable importance as far as fatigue behavior is concerned.

The microsections made of representative welded tube-plate specimens indicated that both tubing and plate had the usual degree of surface decarburization, although in the heat-affected zone where fatigue failure occurred, it was not so readily discernible as in the unaffected steel. It is quite probable that the decarburized surface, with its attendant lower tensile strength and fatigue properties, contributed to the low fatigue strength observed in the tube-plate and tube-to-tube specimens.

Effect of Modulus of Elasticity

The effect of the modulus of elasticity of the material in the fillets is to diminish the apparent stress concentration as the modulus of the deposited material is reduced. This effect became markedly evident with brazed connections, although the smooth contours of the brazed fillets also contributed to a reduction in the stress concentration.

The actual mechanism by which this action occurs is probably one of plastic flow during the fatigue test, and consequent redistribution of stresses at the toe of the fillets, such that the stress gradient is smoothed and the peak stresses reduced.

General Remarks

It was not the object of these tests to evaluate the fatigue strength and endurance limit of arc-welded joints in aircraft tubing, but rather to make use of repeated-stress tests to compare welds with different contours, more or less penetration, and greater or lesser heat effect on the parent metal, and thus to determine the degree in which these factors are governed by the type of electrode, speed of welding, current, position, preheat, and other related conditions.

The plan of attack was to determine an approximate S-N curve for joints welded under normal or optimum conditions, and to use these data as a base line for tests of joints made under abnormal welding conditions which would produce overlapped and undercut fillets, poor root penetration, incomplete fusion, porosity, and excessive heat effects.

The results of the repeated-stress tests, have, however, pointed in a different direction from welding technique. In every test the effect of stress concentration adjacent to the weld was far greater than the effects of inadequate fusion, penetration, parent-metal hardening, or normal heat treatment after welding. It would appear that joints made with reasonable variations in welding technique have equivalent structural integrity even if the weld is of the lowest acceptable quality. The importance of heat effects, adequate fusion, and weld soundness is not minimized, since these qualities must be obtained to a definite degree. However, if the service conditions for a welded joint such as a tubular cluster demand a consideration of repeated stresses, the governing factor in the strength of the joint seems to be the stress concentration caused by the weld-joint geometry, rather than the internal characteristics of the weld itself.

The tests in this investigation have provided data which confirm some of the concepts relative to the behavior of fillet and butt welds, for example, the superiority of tapered and concave fillets and the deleterious effects of internal weld defects. (See reference 1.) The most significant result has been to show that the stress concentrations caused by normal flat and convex fillets in tubular sections are higher, and exert a greater influence on the strength of welded thin-wall sections, than is generally accepted.

The problem of stress concentration has long been dealt with in the design of machined and cast structures and has also been considered in welded assemblies. In most weldments, however, the component parts are relatively thick, and the welds form either a small proportion of the entire mass or are large enough to form an integral, flowing section of the assembly. If a tubular aircraft assembly is scaled up to the proportions of an ordinary weldment, it is evident that the welds do not scale up in the same proportion. It would be considered bad practice to join two 1/4-inch plates with a 3/4-inch fillet which had a 3/4-inch throat, yet, in miniature, this is the type of weld joint that is regularly obtained in 1/16-inch aircraft tubing.

There are no apparent ways of accounting for this scale factor by radical changes in joint design and fusion-welding technique, and it is not suggested that such changes are imperative under present requirements of design and service life. Metal-arc-welding and gas-welding methods for aircraft structures have certain peculiar limitations, but satisfactory performance of fusion-welded aircraft structures has been demonstrated under many service conditions. The electrodes now available for aircraft work deposit tapered or concave fillets only under favorable conditions of position and joint design, but the flat and convex welds normally obtained have worked to no distinct disadvantage, despite the accepted fact that such welds are stress-raisers.

CONCLUDING REMARKS

Many types of specimen have been tested in fatigue in an attempt to differentiate the effects of variations in welding technique. Other investigators have studied small specimens, and aircraft companies have tested full-size motor mounts. The general agreement of fatigue data from these sources is good; however, little fundamental information has been obtained on the effects of welding technique, except that the major factor influencing the failure under repetitive loading of motor mounts is fillet-weld geometry. This conclusion assumes that the material is constant from test to test. Although it seems likely that other factors influence the fatigue resistance of joints in tubular structures, suitable tests or specimens are not readily available for use in determining quantitatively the effect of these variables.

Perhaps the most difficult problem in the selection of a test specimen is the provision for specimen support and load application. In design, the gripping of specimens must be carefully considered to avoid failures at these points which would impair the accuracy of data. A second problem involves the hesitancy of airframe manufacturers to accept any specimen as being typical of aircraft construction unless it is actually a component of such a structure. The view has frequently been expressed that a component from the structure of one airframe would yield data of value only in that specific instance and of no value as applied to other and different conditions.

In order to avoid these problems concerning specimens, it is believed desirable to study models or full-size sections of typical airframes. The question of interchangeability concerning test data may be answered by the use of a motor mount for these tests. It is possible that less variation exists in motor-mount design from one installation to another than in most structures. It may also be possible to derive immediate benefit from such work since the influence of fatigue has been observed in motor-mount structures in service.

The benefit to be derived from tests of these structures may depend to a marked degree on the forethought given to the test program insofar as choice of specimen and loading is concerned. It is suggested that the actual comparison ordinarily desired is one in terms of service life rather than fatigue data at certain arbitrary stress or load levels. It is believed that simulation of actual service loading during tests might have the advantage of being readily interpreted by interested groups, and might make it possible to obtain significant information from a limited number of tests. The limitation of tests may be suitable only in cases in which it is known that the product control is such that uniform structures are assembled.

REFERENCES

1. Voldrich, C. B., and Armstrong, E. T.: Effect of Variables in Welding Technique on the Strength of Direct-Current Metal-Arc-Welded Joints in Aircraft Steel. I - Static Tension and Bending Fatigue Tests of Joints in SAE 4130 Steel Sheet. NACA TN No. 1261, 1947.
2. Williamson, A. J.: Fatigue Studies of Weld Test Triangular Structures with NE8630 Steel Tubing. The Welding Jour., vol. 23, no. 1, Jan. 1944, pp. 27-s - 32-s.
3. Buckwalter, T. V., and Horger, Oscar: Fatigue Strength of Welded Aircraft Joints. The Welding Jour., vol. 23, no. 1, Jan. 1944, pp. 50-s - 58-s.

TABLE 1.— PROPERTIES AND CHEMICAL COMPOSITION OF TUBING, SHEET, PLATE,
AND BAR USED FOR FATIGUE TEST SPECIMENS

Material	Condition (as received)	Chemical composition (mill)							Yield point (psi)	Ultimate tensile strength (psi)	Percent elongation in 2 in.
		C	Mn	P	S	Si	Cr	Mo			
1- by 0.065-in. SAE 4130 seamless tubing	Normalized ¹	0.30	0.46	0.017	0.025	----	1.06	0.19	84,900	118,100	23
1- by 0.095-in. SAE 4130 seamless tubing	Normalized ²	No analysis							-----	-----	--
1/8-in. SAE 4130 sheet	Hot-rolled; normal- ized and drawn	.31 .32	.47 .47	.023 .023	.017 .020	.25 .26	.94 .95	.21 .23	81,400	97,500	22
1/4-in. SAE 4130 plate	Normalized ³	No analysis							-----	-----	--
2- by 2-in. SAE 4140 bar	Hot-rolled	.39	.70	.015	.030	.20	1.06	.18	-----	-----	--

¹Conforms to Army-Navy Specification AN-WW-T-850.

²From Wright Field stock; conforms to Specification 57-180-2D.

³From Wright Field stock; conforms to Specification AN-QQ-S-685.

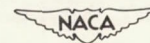

TABLE 2.- WELDING DATA FOR METAL-ARC-WELDED
TUBE-PLATE SPECIMENS, SERIES B¹

[All specimens made with 1- by 0.065-in. SAE 4130 tubing and 1/8-in. SAE 4130 sheet; see figs. 3 and 14.]

Test	Electrode		Initial tube-plate temperature (°F)	Direct current (electrode negative)		Welding time (sec) (2)	Heat treatment after welding	Character of fillet weld	
	Kind	Diameter (in.)		Amperes	Arc volts			Nominal size (in.)	Contour
395	Wilson 520 ³	5/64	70	50-55	22-24	27	None	5/32	Flat to slightly convex
389	-----do-----	5/64	300	45-50	22-24	30	None	5/32	Flat to slightly convex
405	-----do-----	5/64	70	40-45	22-24	27	SR ⁵	5/32	Flat
396	-----do-----	5/64	70	50-55	22-24	27	QD ⁶	5/32	Flat to slightly convex
390	-----do----- ⁴	5/64	300	45-50	22-24	30	QD	5/32	Flat to slightly convex
397	Planeweld 1	5/64	70	40-45	24-26	32	None	5/32	Slightly to moderately convex
399	-----do-----	5/64	300	40-45	24-26	30	None	5/32	Flat to slightly convex
398	-----do-----	5/64	70	40-45	24-26	32	QD	5/32	Slightly to moderately convex
400	-----do-----	5/64	300	40-45	24-26	30	QD	5/32	Flat to slightly convex

¹For each of the nine welding conditions, a maximum of eight tube-plate specimens was welded. Six to seven of the specimens were tested in rotary bending in the machine shown in fig. 22. The test data are summarized in fig. 28 and detailed data are given in table 7 and figs. 4 to 12.

²All specimens welded manually, with the tube tilted 30° from the horizontal and rotated on its axis in the welding jig shown in fig. 13. The welding time shown is for a single circumferential fillet made in two increments.

³AWS Class E6013; plain-carbon-steel deposit.

⁴Alloy-aircraft type; alloy-steel deposit.

⁵SR, stress-relieved 30 min at 1000° F.

⁶QD, quenched in oil after 30 min at 1600° F; drawn 30 min at 900° F.

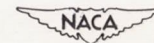

TABLE 3.- WELDING DATA FOR METAL-ARC-WELDED TUBE-PLATE SPECIMENS, SERIES C¹

[All specimens made with 1- by 0.095-in. SAE 4130 tubing and 1/4-in. SAE 4130 plate; see fig. 3.]

Test	Electrode		Direct current			Welding time (sec) (3)	Character of fillet weld	
	Kind (2)	Diameter (in.)	Polarity	Amperes	Arc volts		Nominal size (in.)	Contour
406	Gen. Elect. W-22	1/8	Positive	95-100	24-26	35	7/32	Slightly convex
407	Fleetweld 7	1/8	Negative	100-105	22-24	37	7/32	Flat to slightly convex
408	Wilson 107	1/8	Negative	115-120	18-20	37	7/32	Flat to slightly convex
409	AO Smith SW-15	1/8	Negative	105-110	22-24	35	7/32	Flat to slightly convex
410	Champ. Bluedac	1/8	Negative	100-105	20-22	35	7/32	Slightly convex
411	Westinghouse SW	1/8	Negative	100-105	21-23	35	7/32	Slightly convex
412	Airco 90	1/8	Negative	100-105	20-22	40	7/32	Slightly convex
413	Arcos LC 41	1/8	Positive	105-110	18-20	37	3/16	Convex
414	Champ. Alloy Airc.	1/8	Negative	100-105	22-24	35	7/32	Slightly convex
415	Planeweld 1	1/8	Negative	100-105	21-23	37	7/32	Slightly convex

¹For each of the ten electrodes, three or four tube-plate specimens were welded, and then tested in rotary bending in the machine shown in fig. 22. The test data are given in fig. 31 and table 8.

²Plain-carbon-steel electrodes, tests 406-412. Alloy-aircraft electrodes, tests 413-415.

³All specimens welded manually, with the tube tilted 30° from the horizontal and rotated on its axis in the welding jig shown in fig. 13. The welding time shown is for a single circumferential fillet made in one increment. The initial temperature of all specimens was about 70° F. There was no heat treatment after welding.

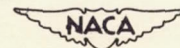

TABLE 4.- DATA FOR WELDED, BRAZED, AND MACHINED TUBE-PLATE SPECIMENS, SERIES D

Type of specimen (1)	Test	Electrode or welding rod (2)	Direct current			Initial temperature (°F)	Character of fillet			Heat treatment before fatigue test (3)
			Polarity	Amperes	Arc volts		Nominal size (in.)	Number of layers	Contour	
Arc welded ⁴	472A	5/64-in. Wilson 520	Negative	55-60	22-25	350	1/8	1	Concave to flat	N
Do. ⁴ -----	Series B	(12)	(12)	(12)			5/32	1	Flat to moderately convex	(12)
Do. ⁴ -----	483	3/32-in. Wilson 520	Negative	60-65	18-22	80	3/16	1	Flat	A
Do. ⁴ -----	480A	3/32-in. Wilson 520	Negative	58-65	20-24	80	3/16	1	Flat	FS
Do. ⁴ -----	472G	3/32-in. Wilson 520	Negative	60-65	20-23	300	3/16	1	Flat to concave	N
Do. ⁴ -----	524	3/32-in. Smith SW15	Negative	65-70	22-24	80	3/16	1	Fully concave ¹⁴	None
Do. ⁴ -----	525	3/32-in. Smith SW15	Negative	55-60	19-21	80	3/16	1	Fully convex ¹⁵	None
Do. ⁴ -----	523A	1/8-in. Stainweld D	Positive	65-70	25-27	80	3/16	1	Flat	None
Do. ⁴ -----	472C	1/8-in. Wilson 520	Negative	80-85	20-23	80	7/32	1	Flat to convex	N
Do. ⁵ -----	Series C	(13)	(13)	(13)			7/32	1	Flat to slightly convex	None
Do. ⁴ -----	472B	5/64-in. Wilson 520	Negative	55-60	22-25	350	1/4	2	Flat to slightly convex	N
Do. ⁴ -----	472B	1/8-in. Wilson 520	Negative	85-90	20-23	80				
Do. ⁴ -----	507	3/32-in. Wilson 520	Negative	60-65	22-24	80	3/16 by 3/8	3	See figure 16	N
Do. ⁴ -----	472D	5/64-in. Wilson 520	Negative	45-50	25-27	80				
Do. ⁴ -----	472D	3/32-in. Wilson 520	Negative	60-65	20-23	300	3/16 by 3/4	4	See figure 16	N
Arc welded ⁶	X	5/64-in. Wilson 520	(16)	(16)	(16)		3/32	1	Machined concave from 5/32-in.	(16)
Do. ⁷ -----	Y	5/64-in. Wilson 520	(17)	(17)	(17)		5/32	1	Machined concave at toe	(17)
Arc welded ⁸	472H	3/32-in. Wilson 520	Negative	85-90	20-23	500	7/32	1	Flat	N
Arc welded ⁹	479A	5/64-in. Wilson 520	Negative	50-55	24-26	80	5/32	1	Flat to slightly convex	None
Do. ¹⁰ -----	479B	5/64-in. Wilson 520	Negative	50-55	24-26	80	5/32	1	Flat to slightly convex	None
Gas welded ⁴	472E	1/16-in. Oxweld 7	-----	-----	-----	-----	3/16	1	Moderately concave	N
Do. ⁴ -----	472F	1/16-in. Oxweld 7	-----	-----	-----	-----	1/4	1	Moderately concave	N
Do. ⁴ -----	480D	1/16-in. Oxweld 7	-----	-----	-----	-----	7/32 by 7/16	3	See figure 16	N
Brazed ⁴	480EF	1/8-in. Oxweld 25M	-----	-----	-----	-----	3/16	1	Fully concave	None
Do. ⁴ -----	480E	1/8-in. Oxweld 25M	-----	-----	-----	-----	5/16	1	Moderately to fully concave	None
Machined only ¹¹	480C1	No weld	-----	-----	-----	-----	0.25	-	Fully convex (fig. 2)	Nx
Do. ¹¹ -----	480C2	No weld	-----	-----	-----	-----	0.25	-	Fully concave (fig. 2)	Nx

¹All specimens tested in rotary bending, except 479A, tested in repeated axial tension and compression, and 479B, tested in axial repeated tension. For fatigue test data, see figs. 16 and 36 and table 9.

²Wilson 520 and Smith SW15 are negative-polarity, plain-carbon-steel electrodes. Stainweld D is a 25 Cr - 20 Ni austenitic-steel electrode. Oxweld 7 is a low-carbon-steel welding rod. Oxweld 25M is a bronze welding rod.

³N, normalized 30 min at 1650° F, air-cooled. Nx, normalized 30 min at 1700° F, air-cooled. A, annealed 30 min at 1650° F, furnace-cooled.

⁴FS, flame softened with oxyacetylene torch, in tube at toe of fillet.

⁵1- by 0.065-in. SAE 4130 seamless tubing and 1/8-in. SAE 4130 steel sheet (figs. 3 and 14). No. 4 tip (Linde) used on welding torch for gas-welded and brazed specimens.

⁶1- by 0.095-in. SAE 4130 seamless tubing and 1/4-in. SAE 4130 steel plate (fig. 3).

⁷Same as footnote 4, with welded fillet machined fully concave.

⁸Same as footnote 4, with welded fillet machined concave at toe.

⁹1-in. SAE 4130 solid round bar and 1/8-in. SAE 4130 steel sheet (see detail, fig. 16).

¹⁰Same as footnote 4, with plates welded at both ends of tube.

¹¹Same as footnote 1, with tubes welded to both sides of plate (similar to specimens for prestress tests, fig. 18).

¹²Specimens machined to dimensions given in footnote 4 from solid SAE 4140 steel forgings, with machined fillets to simulate fillet welds (figs. 1 and 2).

¹³See table 2; one specimen each from tests 390, 395, 396, 397, 399, and 400; two from test 398.

¹⁴See table 3; one specimen each from tests 406, 407, 411, 412, 414, and 415.

¹⁵To obtain a fully concave fillet, specimen was rotated in welding jig with tube in horizontal position, and welding done from the side to produce a "vertical down" fillet.

¹⁶To obtain a fully convex fillet, specimen was rotated in welding jig with tube in horizontal position, and welding done from the side to produce a "vertical up" fillet.

¹⁷See table 2; one specimen each from tests 389, 390, and 396.

¹⁸See table 2; one specimen each from tests 395 and 405.

¹⁹Fatigue test data given in figs. 16 and 36 and in table 9.

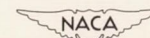

TABLE 5.- WELDING DATA FOR TUBULAR SPECIMENS
OF SERIES E, F, G, AND H¹

Series	Type	Test	Type of weld	Electrode or weld rod	Character of fillet	Heat treatment after welding (2)
E	Notched ³	480B	Oxyacetylene	1/16-in. Oxweld 7	Three-layer fillet; see fig. 17	Normalized
	Notched ⁴	506	Oxyacetylene	-----do-----	-----do-----	Normalized
	Notched ⁵	523B	Arc	1/8-in. Stainweld D	3/16-in. flat fillet	None
F	For prestress tests ⁶	645	Arc	5/64-in. Wilson 520	7/32-in. flat fillet	None
		646	Arc	-----do-----	-----do-----	None
		647	Arc	-----do-----	-----do-----	Full annealed ⁹
G	For shot-peening tests ⁷	770	Arc	5/64-in. Wilson 520	7/32-in. flat fillet	None
H	For reversed ⁸ -bending tests	569	Arc	3/32-in. Smith SW15	See figs. 21 and 39	None

¹Fatigue test data given in figs. 26, 37, and 38 and tables 10 to 13.

²All steel in normalized condition before welding; no preheat used.

³Same as series D, test 480D, except with circumferential notch in tube 0.038 in. deep (see fig. 17).

⁴Same as series D, test 480D, except with circumferential notch in tube 0.030 in. deep (see fig. 17).

⁵Same as series D, test 523A, except with circumferential notch in tube 0.030 in. deep.

⁶Similar to series B specimens, except with two tubes (see fig. 18).

⁷Same as series B specimens; shot-peened after welding.

⁸Tube-to-tube specimens (see fig. 20).

⁹Packed in cast-iron shot, heated to 1575°-1600° F for 30 min, furnace-cooled.

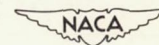

TABLE 6.- ROTARY-BENDING TEST DATA FOR MACHINED
CONCAVE-FILLET TUBE-PLATE SPECIMENS
(BASIC), SERIES A

Test (1)	Load (lb) (2)	Stress (psi) (3)	Cycles	Location of failure
M-1	49	7.0×10^3	$4,800.0 \times 10^3$	No failure
-2	70	10.0	6,500.0	No failure
-3	87	12.5	1,800.0	T ⁴
-4	105	15.0	320.0	T
-5	147	21.0	96.0	T
-6	192	27.5	10.0	T
-7	245	35.0	.5	T

¹The stress data are plotted in fig. 24.

²See fig. 15.

³Nominal tension-compression stress in tube at toe of concave fillet.

⁴T, failure in tube at toe of concave fillet; fracture sometimes extended into fillet.

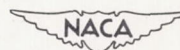

TABLE 7.- ROTARY-BENDING TEST DATA FOR METAL-ARC-WELDED TUBE-PLATE SPECIMENS, SERIES B¹

[1- by 0.065-in. tubing, 1/8-in. plate]

30

Test	Load (lb) (2)	Stress (psi) (3)	Cycles	Location of failure (4)	Test	Load (lb) (2)	Stress (psi) (3)	Cycles	Location of failure (4)
395	24	3.4×10^3	$7,661.3 \times 10^3$	None	397	39	5.6×10^3	$3,000.1 \times 10^3$	None
	39	5.6	387.9	T		46	6.6	169.0	T
	76	10.9	81.1	T		57	8.1	134.4	T
	156	22.3	34.5	T		76	10.9	154.0	T
	206	29.4	13.5	T		105	15.0	42.5	T
389	39	5.6	562.7	T	399	156	22.3	27.7	T
	39	5.6	195.5	TW		245	35.0	6.0	Px
	43	6.2	105.0	T		36	5.2	780.9	T
	58	8.3	211.3	T		43	6.2	219.6	T
	76	10.9	102.8	T		62	8.8	249.8	T
	206	29.4	7.4	T		105	15.0	56.4	T
405	25	3.6	971.6	T	398	147	21.0	13.8	T
	25	3.6	385.2	T		180	25.8	20.8	T
	32	4.6	455.8	T		226	32.2	9.7	T
	51	7.3	226.3	T		39	5.6	250.4	T
	73	10.4	70.3	T		58	8.3	99.9	T
	112	16.0	32.1	T		97	13.8	20.4	T
396	49	7.0	212.4	TW	400	147	21.0	17.8	T
	58	8.3	183.8	T		156	22.3	18.1	T
	76	10.9	64.9	T		25	3.6	170.4	T
	103	14.8	36.3	T		38	5.5	96.6	T
	156	22.3	17.1	T		74	10.5	31.6	T
	254	36.4	3.6	T		105	15.0	51.0	T
390	32	4.6	330.7	T	156	22.3	21.0	T	
	32	4.6	230.1	TW					
	39	5.6	447.8	T					
	58	8.3	243.8	T					
	85	12.1	89.5	T					
	156	22.3	13.0	T					

¹The data given in this table were used in the preparation of the comparison graphs for series B specimens, figs. 4 to 12 and 28.²See fig. 15.³Nominal tension-compression stress in tube of toe of fillet weld.⁴T, failure in tube at toe of fillet weld.

TW, same as T with partial failure through throat of fillet weld.

Px, failure in plate at toe of fillet weld, possibly through welding crack.

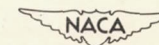

TABLE 8.- ROTARY-BENDING TEST DATA FOR METAL-ARC-WELDED TUBE-PLATE SPECIMENS, SERIES C¹

[1- by 0.095-in. tubing; 1/4-in. plate]

Test	Load (lb) (2)	Stress (psi) (3)	Cycles	Location of failure (4)	Test	Load (lb) (2)	Stress (psi) (3)	Cycles	Location of failure (4)
406	41	4.4×10^3	$1,872.8 \times 10^3$	T	411	38	4.1×10^3	$1,630.0 \times 10^3$	None ⁵
	188	20.2	48.7	T		53	5.7	355.8	T
	284	30.4	28.7	T		150	16.1	65.0	T
407	53	5.7	496.3	T	412	188	20.2	47.9	T
	111	11.9	124.2	T		33	3.5	6,800.7	None ⁶
	188	20.2	41.9	T		47	5.0	790.3	T
	284	30.4	19.6	T		150	16.1	88.0	T
408	38	4.1	9,431.3	None	413	188	20.2	60.3	T
	111	11.9	134.7	T		53	5.7	331.2	T
	228	24.4	26.8	T		150	16.1	70.1	T
409	73	7.8	1,290.4	T	414	247	26.4	21.6	T
	111	11.9	311.0	T		130	14.0	126.9	T
	150	16.1	101.7	T		204	22.0	49.1	T
	265	28.4	30.8	T		284	30.4	27.1	T
410	150	16.1	70.9	T	415	111	11.9	145.1	T
	228	24.4	33.7	T		188	20.2	48.1	T
							284	30.4	17.8

¹The data given in this table were used in the preparation of the comparison graph for series C specimens, fig. 31.

²See fig. 15.

³Nominal tension-compression stress in tube at toe of fillet weld.

⁴T, failure in tube at toe of fillet weld.

⁵Second run at 11,900 psi with failure T at 242,000 cycles.

⁶Second run at 4,100 psi, no failure at 3,180,000 cycles.

Third run at 5,700 psi, no failure at 3,600,000 cycles.

Fourth run at 7,800 psi, with failure T at 494,800 cycles.

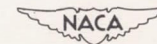

TABLE 9.- REPEATED-STRESS DATA FOR WELDED, BRAZED, AND MACHINED TUBE-PLATE SPECIMENS, SERIES D¹

Test (2)	Load (lb) (3)	Stress (psi) (4)	Cycles	Location of failure (5)	Test (2)	Load (lb) (3)	Stress (psi) (4)	Cycles	Location of failure (5)	Test (2)	Load (lb) (3)	Stress (psi) (4)	Cycles	Location of failure (5)			
From series B	472A	147	21.0 × 10 ³	9.2 × 10 ³	T	From series C	523A	147	21.0 × 10 ³	43.1 × 10 ³	472H	147	69.2 × 10 ³	221.5 × 10 ³	P		
		147	21.0	6.4	T			147	21.0	35.2	T	147	69.2	183.0	P		
		147	21.0	17.8	T			147	21.0	33.2	T						
		147	21.0	13.8	T			472C	147	21.0	19.1	T	479A	---	(7)	16.7	TW
		147	21.0	34.5	T			147	21.0	16.5	T		---	(7)	9.9	T	
		156	22.3	27.7	T							479B	---	(8)	94.8	P	
		156	22.3	21.0	T							---	(8)	92.6	P		
		156	22.3	18.1	T			412-4	188	20.2	60.3	T					
		156	22.3	17.1	T			406-3	188	20.2	48.7	T	472E	147	21.0	29.2	T
		156	22.3	13.0	T			415-3	188	20.2	48.1	T	147	21.0	13.5	T	
483	147	21.0	9.9	T		411-3	188	20.2	47.9	T	472F	147	21.0	36.5	T		
	147	21.0	7.5	T		407-3	188	20.2	41.9	T	147	21.0	21.8	T			
	147	21.0	5.0	T		414-1	205	22.0	49.1	T							
480A	147	21.0	26.0	T		472B	147	21.0	29.7	T	480D	147	21.0	610.0	T		
	147	21.0	25.0	T		147	21.0	16.1	16.1	T	147	21.0	325.0	T			
	147	21.0	17.6	T		507	147	21.0	281.7	T	147	21.0	279.0	T			
472G	147	21.0	25.2	T		147	21.0	270.9	P	480EF	147	21.0	186.0	B			
	147	21.0	22.0	T		472D	147	21.0	197.3	W	147	21.0	94.0	BT			
524	147	21.0	104.8	T		147	21.0	188.9	W	147	21.0	28.8	BT				
	147	21.0	55.7	T		X	147	21.0	3.3	W	480E	147	21.0	506.0	T		
	147	21.0	42.3	T		147	21.0	2.2	2.2	W	480C1	147	21.0	91.0	T		
525	147	21.0	32.4	TP		147	21.0	1.1	1.1	W	480C2	147	21.0	354.0	TW		
	147	21.0	29.4	T		Y	147	21.0	15.0	T							
	147	21.0	28.0	P		147	21.0	13.0	13.0	T							

¹All rotary bending (see fig. 22) except test 479A, which were axial tension and compression and test 479B which were axial repeated tension.

²Averages of the load data are plotted in fig. 16. The data were also used in preparing the comparison graph for series D specimens, fig. 36.

³See fig. 15.

⁴Nominal tension-compression stress in tube at toe of fillet (except test 479B).

⁵T, failure in tube at toe of fillet.

⁶P, failure in plate at toe of fillet.

⁷W, failure in throat of fillet.

⁸B, failure in bond between brazing metal and plate.

⁹Stress in solid 1-in. round bar at toe of fillet weld; same load as for stress of 21,000 psi in 1- by 0.065-in. tube.

¹⁰Axial tension-compression stress in tube:

Maximum tension 21,500 psi
 Maximum compression 24,600 psi
 Stress range 46,100 psi
 Mean stress 1,550 psi compression

¹¹Axial repeated-tension stress in tube:

Maximum tension 21,000 psi
 Minimum tension 1,000 psi
 Stress range 20,000 psi
 Mean stress 11,000 psi tension

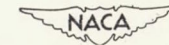

TABLE 10.— ROTARY-BENDING TEST DATA FOR NOTCHED
TUBE-PLATE SPECIMENS, SERIES E¹

[1— by 0.065-in. tube; 1/8-in. plate]

Type of specimen	Test	Load (lb) (2)	Stress (psi) (3)	Cycles	Location of failure
Tapered gas-welded fillet; 0.038-in. notch (fig. 17)	480B	150	47.4×10^3	1.2×10^3	Notch
		150	47.4	1.1	Notch
		150	47.4	1.0	Notch
Tapered gas-welded fillet; 0.030-in. notch (fig. 17)	506	20	4.8	2534.8	Notch
		30	7.2	278.2	Notch
		55	13.2	158.8	Notch
		87	21.0	30.1	Notch
		140	33.6	6.5	Notch
Metal arc-welded fillet; 0.030-in. notch	523B	30	(4)	3791.9	Tube ⁴
		55	13.0	106.7	Notch
		87	21.0	39.1	Notch

¹The data given in this table were used in the preparation of the comparison graph for series E specimens, fig. 26.

²See fig. 15.

³Normal tension-compression stress at root of notch.

⁴7,200 psi in tube at root of 0.030-in. notch; 4,200 psi in tube at toe of metal arc weld, where failure took place.

TABLE 11.— ROTARY-BENDING-TEST DATA FOR METAL—

ARC-WELDED SPECIMENS PRESTRESSED

BEFORE FATIGUE TEST SERIES F¹

Type of specimen	Test	Load (lb) (2)	Stress (psi) (3)	Cycles	Location of failure (4)
Similar to type B; tested as welded	645-3	35	5.0×10^3	$3,562.2 \times 10^3$	T
	-5	70	10.0	321.4	T
	-2	105	15.0	122.6	T
	-6	140	20.0	45.2	T
	-1	172	24.5	38.2	T
	-4	210	30.0	9.9	T
Similar to type B; prestressed before fatigue test ⁵	646-6	35	5.0	965.9	T
	-5	70	10.0	296.1	T
	-4	105	15.0	131.4	T
	-3	140	20.0	50.9	T
	-2	175	25.0	18.0	T
	-1	210	30.0	9.8	T
Similar to type B; annealed and prestressed before fatigue test ⁶	647-4	35	5.0	766.4	T
	-6	70	10.0	169.7	T
	-5	105	15.0	28.3	T
	-3	140	20.0	5.7	T
	-2	175	25.0	3.7	T
	-1	210	30.0	2.7	T

¹The data given in this table were used in the preparation of the comparison graph for series F specimens, fig. 37.

²See fig. 15.

³Nominal tension-compression stress in tube at toe of fillet weld.

⁴T, failure in tube at toe of fillet weld.

⁵Loaded in axial static tension beyond yield point of tubing (85,000-90,000 psi).

⁶Furnace annealed at 1600° F, then loaded beyond yield point of tubing (about 45,000-50,000 psi).



TABLE 12.- ROTARY-BENDING TEST DATA FOR METAL-
ARC-WELDED TUBE-PLATE SPECIMENS, SHOT-
PEENED BEFORE FATIGUE TEST, SERIES G¹

Type of specimen	Test	Load (lb) (2)	Stress (psi) (3)	Cycles	Location of failure (4)
Similar to type B; tested as welded	770-19	35	5.0×10^3	$1,906.2 \times 10^3$	T
	-20	70	10.0	128.2	T
	-21	105	15.0	53.9	T
	-22	140	20.0	25.7	T
	-23	210	30.0	6.6	T
	-24	280	40.0	1.8	T
	Similar to type B; shot-peened before fatigue test	770-7	35	5.0	1,792.3
-9		35	5.0	1,142.0	T
-10		53	7.5	10,000.0	NF
-18		53	7.5	10,000.0	NF
-6		53	7.5	345.9	T
-5		70	10.0	4,271.2	T
-17		70	10.0	153.1	T
-4		105	15.0	234.0	T
-11		105	15.0	133.3	T
-3		140	20.0	58.9	T
-12		140	20.0	26.2	T
-13		175	25.0	19.2	T
-2		210	30.0	9.9	T
-14		210	30.0	7.1	T
-8		245	35.0	3.5	T
-15		245	35.0	3.2	T
-16		280	40.0	2.3	T
-1	280	40.0	2.2	T	



¹The data given in this table were used in the preparation of the comparison graph for series G specimens, fig. 38.

²See fig. 15.

³Nominal tension-compression stress in tube at toe of fillet weld.

⁴T, failure in tube at toe of fillet weld.

NF, no failure.

TABLE 13.— ~~REVERSED-BENDING TEST DATA FOR METAL-~~
 ARC-WELDED TUBULAR "PI" SPECIMENS,
 SERIES H

Test	End Load (lb) (1)	Stress (psi) (2)	Cycles	Location of failure (3)
569-4	31	7.0×10^3	(4)	T _a
-3	44	10.0	(4)	T _b
-2	44	10.0	369.0×10^3	T _b
-5	48	10.8	138.0	T _b
-1	48	10.8	171.0	T _b



¹See fig. 23.

²Nominal tension-compression stress in long tubes at toe of fillet weld.

³T_a, failure in short tube at toe of fillet weld ((1), fig. 39).

T_b, failure in long tube at toe of fillet weld ((2), fig. 39).

⁴Fatigue machine did not stop automatically when specimen failed; no cycle reading available.

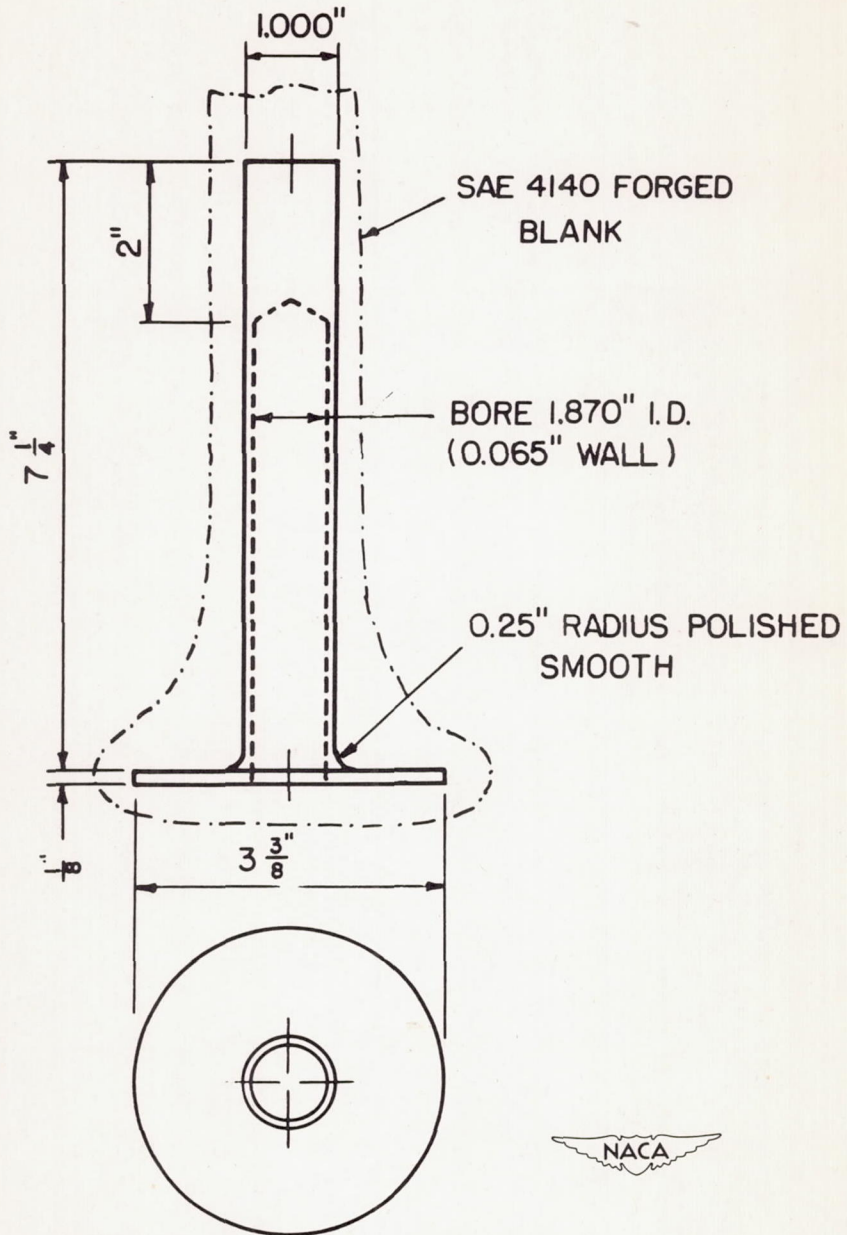

Figure 1.- Basic rotary-bending test specimen, series A, machined from solid bar to simulate welded tube-plate specimens.

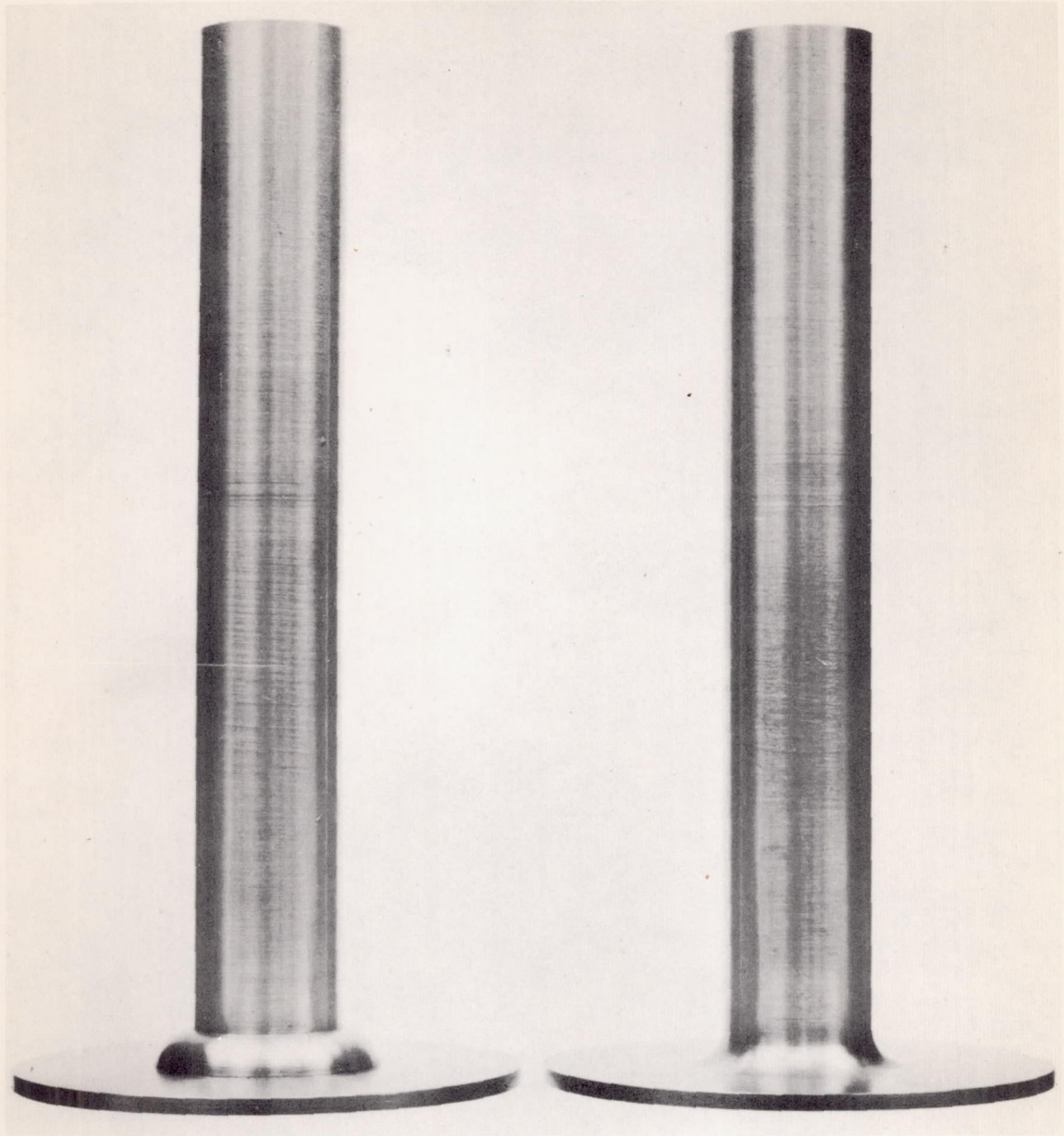

Figure 2.- Machined tube-plate specimens (no weld) for rotary-bending test. Concave-fillet specimen at right used as standard in comparison tests with welded specimens.

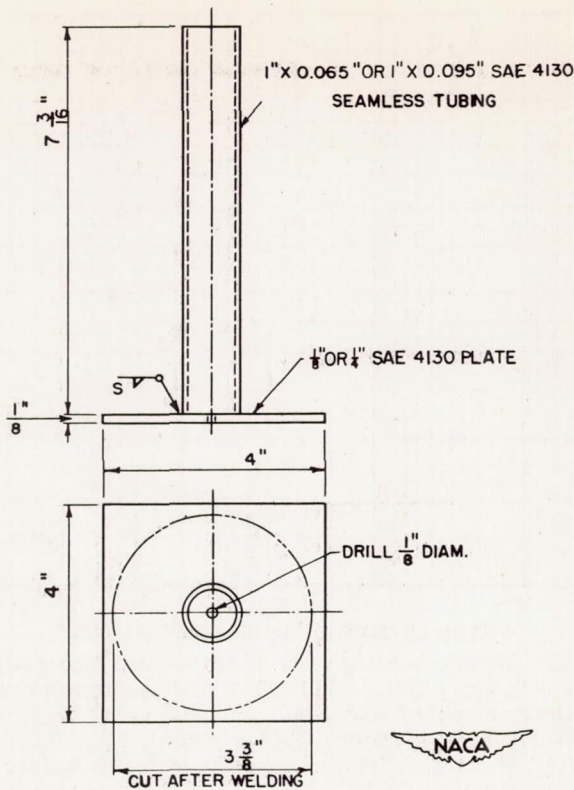

Figure 3.- Metal-arc-welded tube-plate specimen for rotary-bending test.

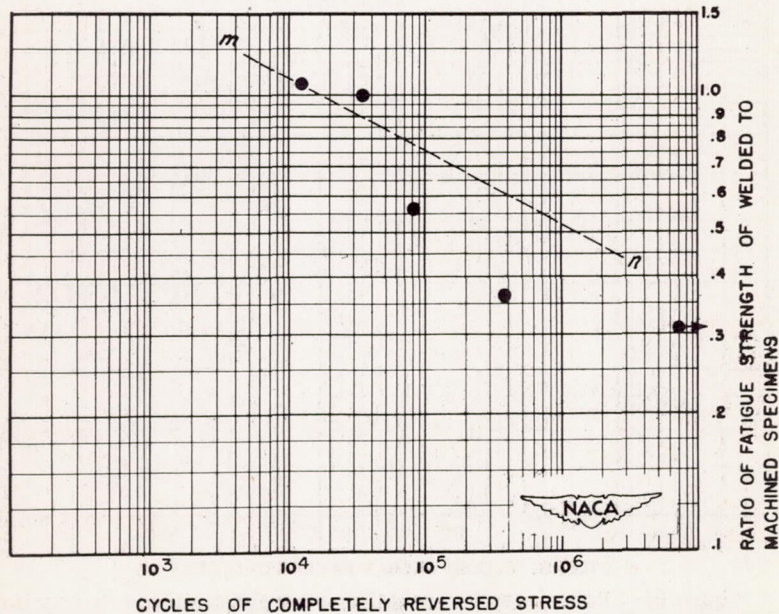

Figure 4.- Rotary-bending tests of arc-welded tube-plate specimens, series B, group 395. Comparison of strength relative to an arbitrary standard machined from solid bar. Electrodes, carbon steel; initial temperature, 70° F; tubing, 1- by 0.065-inch SAE 4130; plate, 1/8-inch SAE 4130; tested as welded. (Datum line mn from fig. 26.)

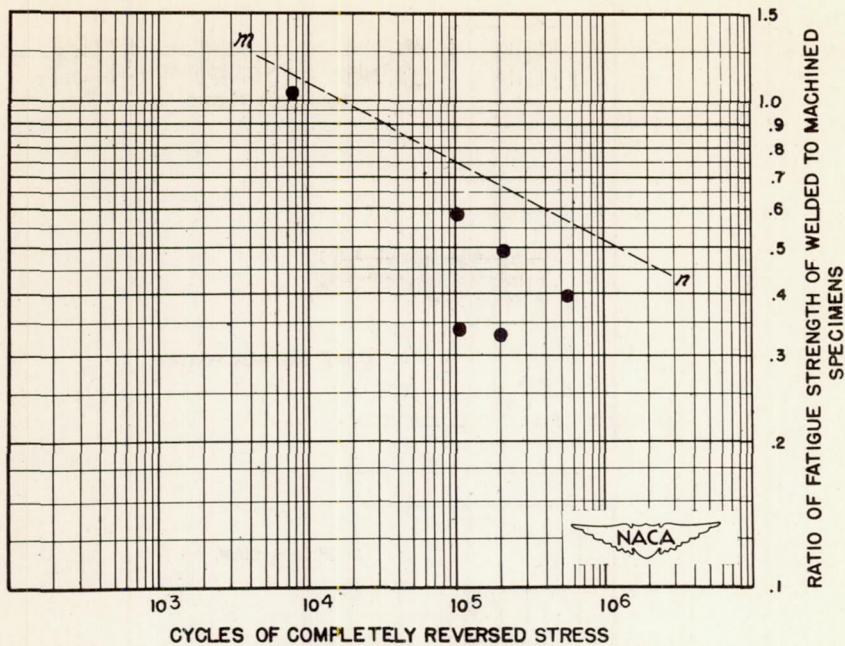

Figure 5.- Rotary-bending tests of arc-welded tube-plate specimens, series B, group 389. Comparison of strength relative to an arbitrary standard machined from solid bar. Electrodes, carbon steel; initial temperature, 300° F; tubing, 1- by 0.065-inch SAE 4130; plate, 1/8-inch SAE 4130; tested as welded. (Datum line mn from fig. 26.)

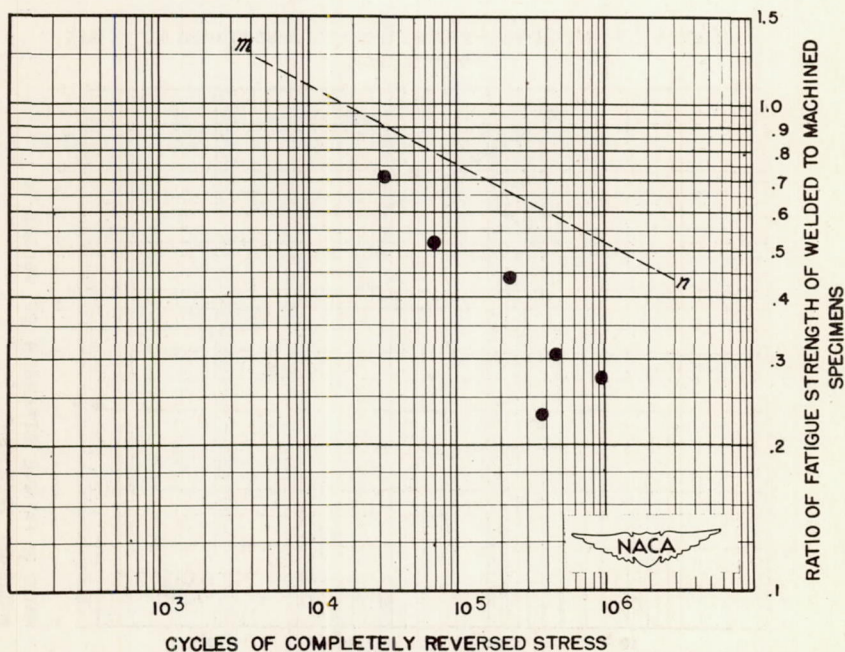

Figure 6.- Rotary-bending tests of arc-welded tube-plate specimens, series B, group 405. Comparison of strength relative to an arbitrary standard machined from solid bar. Electrodes, carbon steel; initial temperature, 70° F; tubing, 1- by 0.065-inch SAE 4130; plate, 1/8-inch SAE 4130; tested stress relieved. (Datum line mn from fig. 26.)

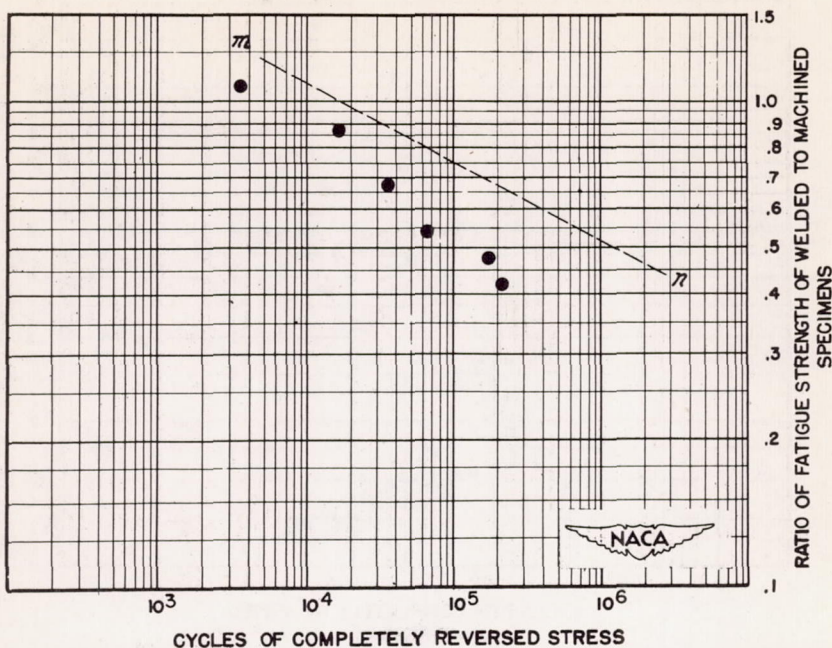

Figure 7.- Rotary-bending tests of arc-welded tube-plate specimens, series B, group 396. Comparison of strength relative to an arbitrary standard machined from solid bar. Electrodes, carbon steel; initial temperature, 70° F; tubing, 1- by 0.065-inch SAE 4130; plate, 1/8-inch SAE 4130; tested quenched and drawn. (Datum line mn from fig. 26.)

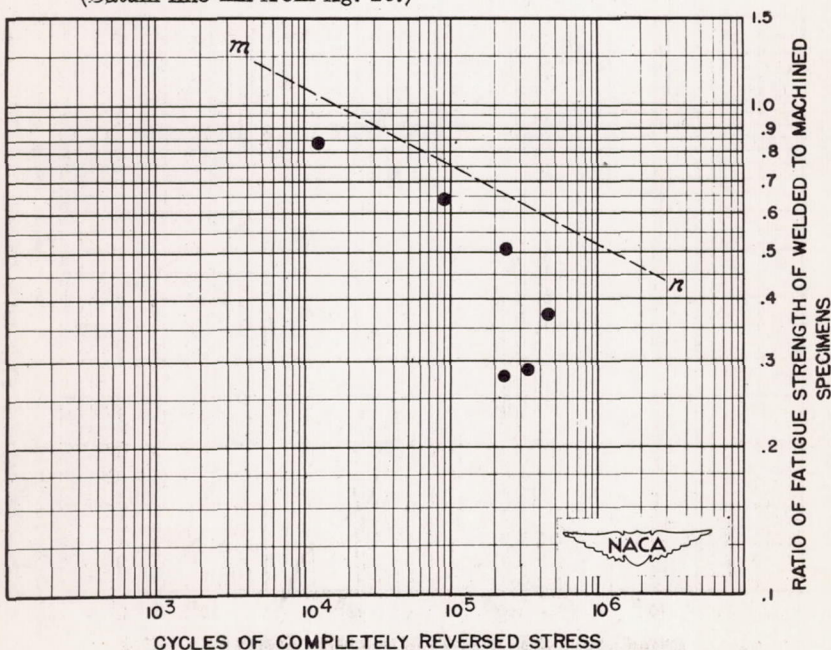

Figure 8.- Rotary-bending tests of arc-welded tube-plate specimens, series B, group 390. Comparison of strength relative to an arbitrary standard machined from solid bar. Electrodes, carbon steel; initial temperature, 300° F; tubing, 1- by 0.065-inch SAE 4130; plate, 1/8-inch SAE 4130; tested quenched and drawn. (Datum line mn from fig. 26.)

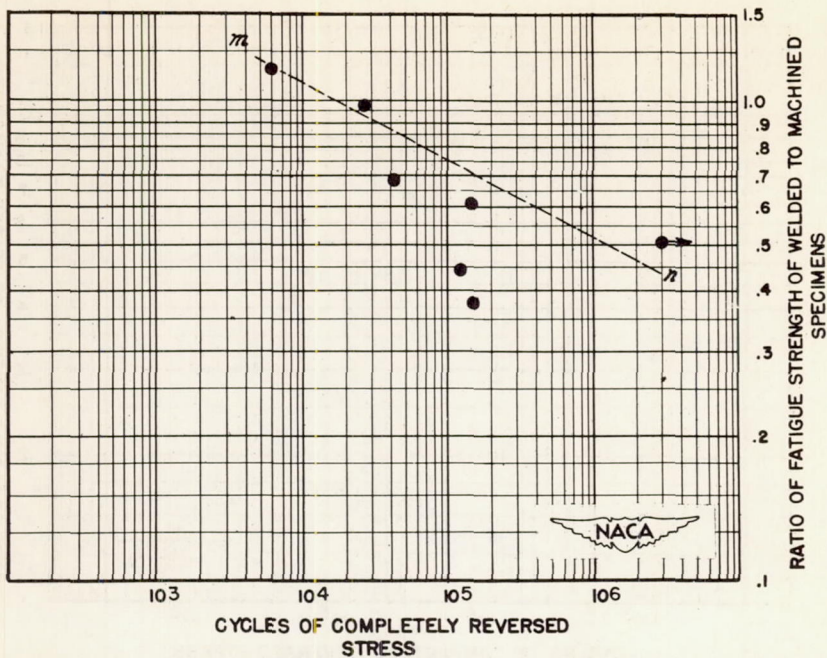

Figure 9.- Rotary-bending tests of arc-welded tube-plate specimens, series B, group 397. Comparison of strength relative to an arbitrary standard machined from solid bar. Electrodes, alloy steel; initial temperature, 70° F; tubing 1-by 0.065-inch SAE 4130; plate, 1/8-inch SAE 4130; tested as welded. (Datum line mn from fig. 26.)

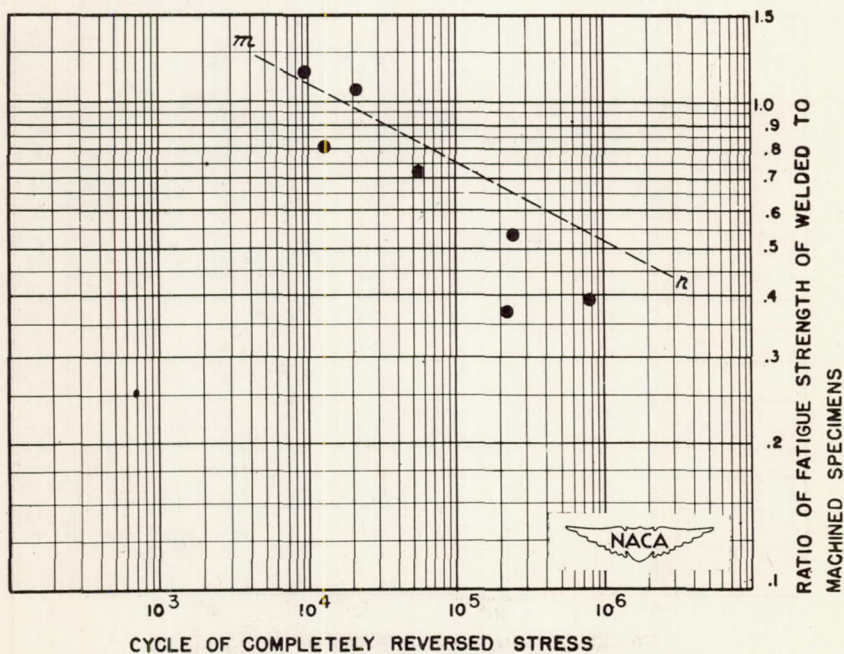

Figure 10.- Rotary-bending tests of arc-welded tube-plate specimens, series B, group 399. Comparison of strength relative to an arbitrary standard machined from solid bar. Electrodes, alloy steel; initial temperature, 300° F; tubing, 1-by 0.065-inch SAE 4130; plate, 1/8-inch SAE 4130; tested as welded. (Datum line mn from fig. 26.)

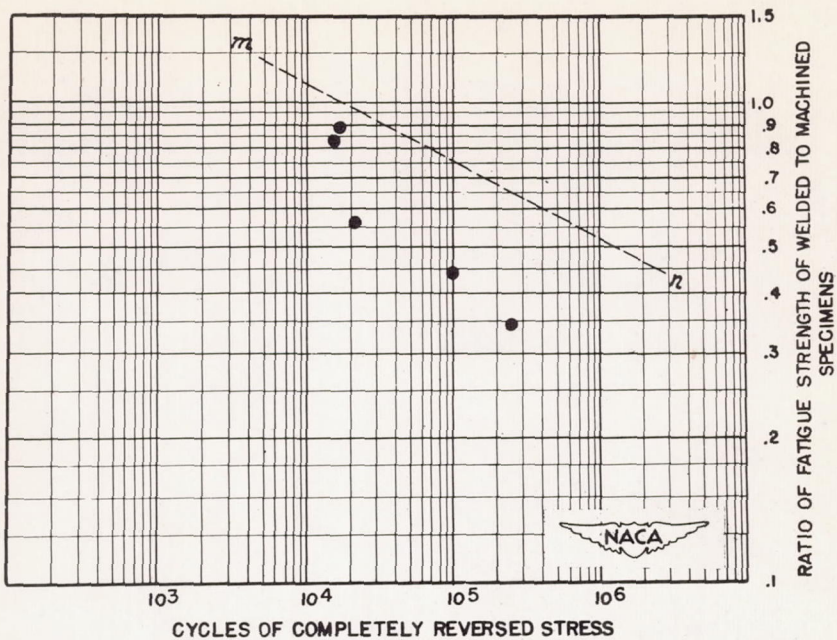

Figure 11.- Rotary-bending tests of arc-welded tube-plate specimens, series B, group 398. Comparison of strength relative to an arbitrary standard machined from solid bar. Electrodes, alloy steel; initial temperature, 70° F; tubing, 1- by 0.065-inch SAE 4130; plate, 1/8-inch SAE 4130; tested quenched and drawn. (Datum line mn from fig. 26.)

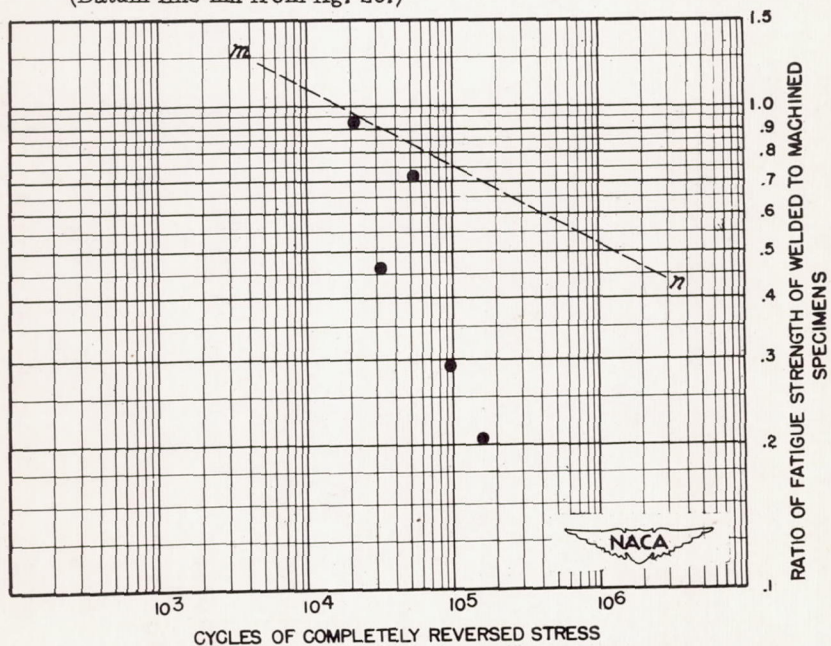

Figure 12.- Rotary-bending tests of arc-welded tube-plate specimens, series B, group 400. Comparison of strength relative to an arbitrary standard machined from solid bar. Electrodes, alloy steel; initial temperature, 300° F; tubing, 1- by 0.065-inch SAE 4130; plate, 1/8-inch SAE 4130; tested quenched and drawn. (Datum line mn from fig. 26.)

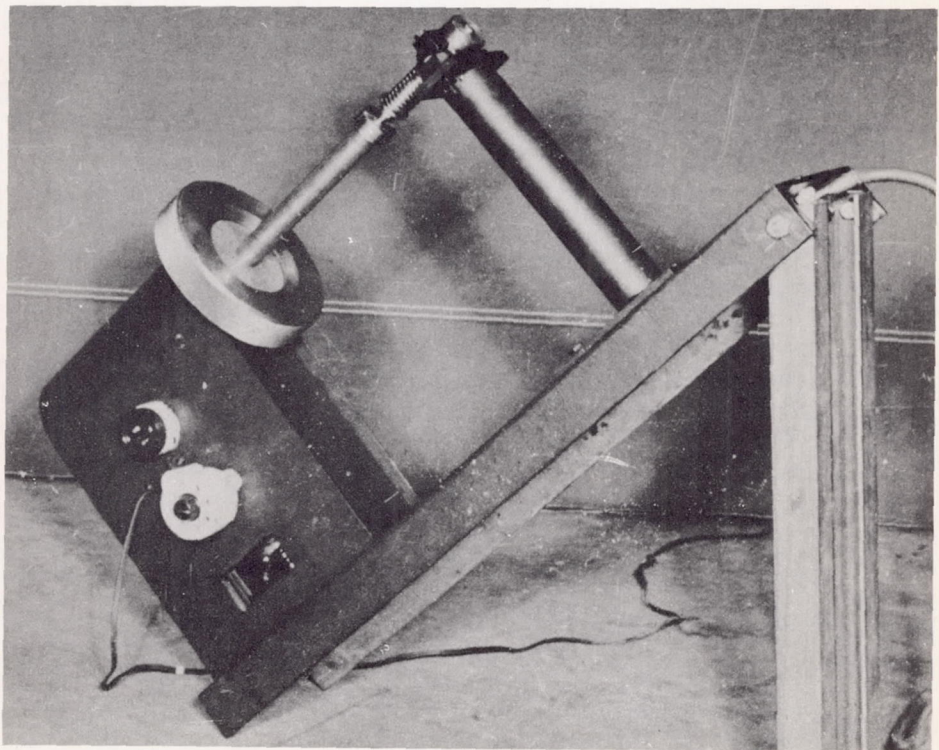
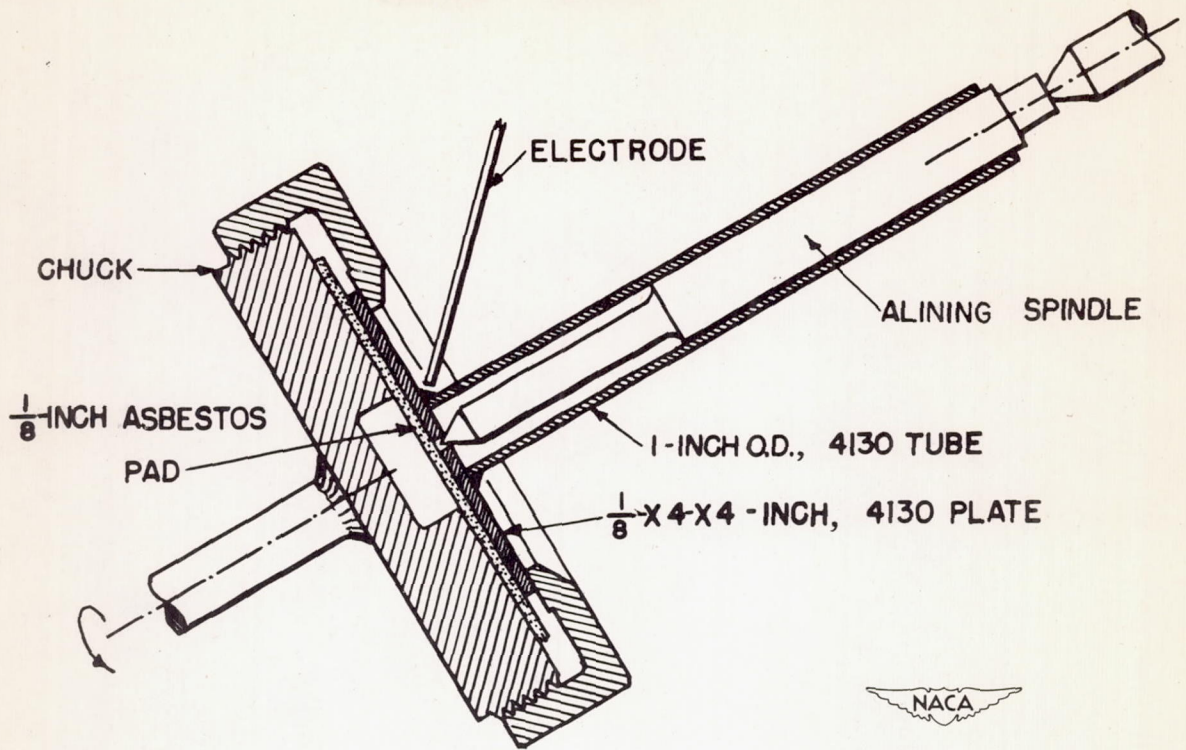

Figure 13.- Welding jig for tube-plate specimen.

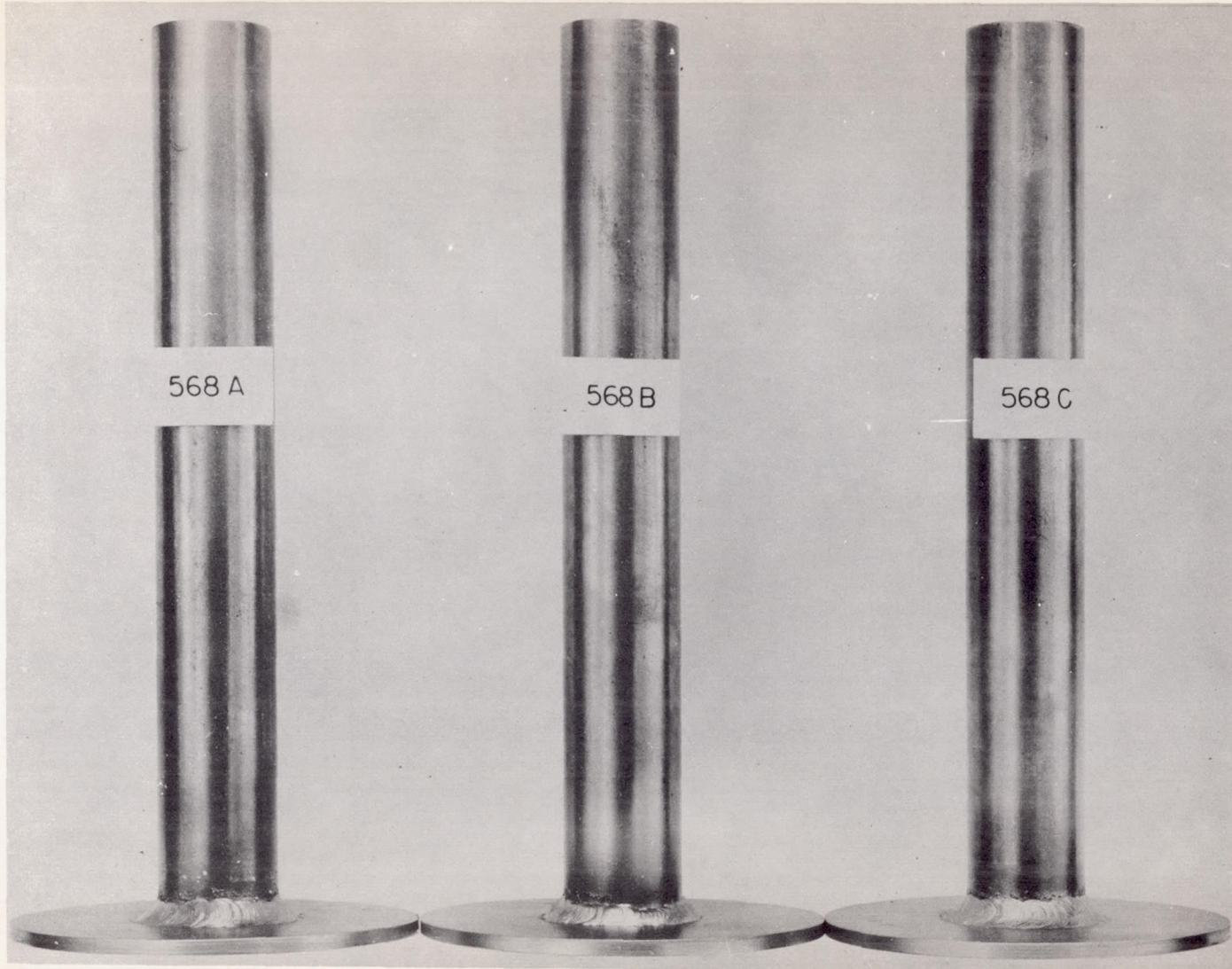
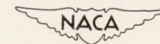

Figure 14.- Typical arc-welded tube-plate specimens for rotary-bending test.



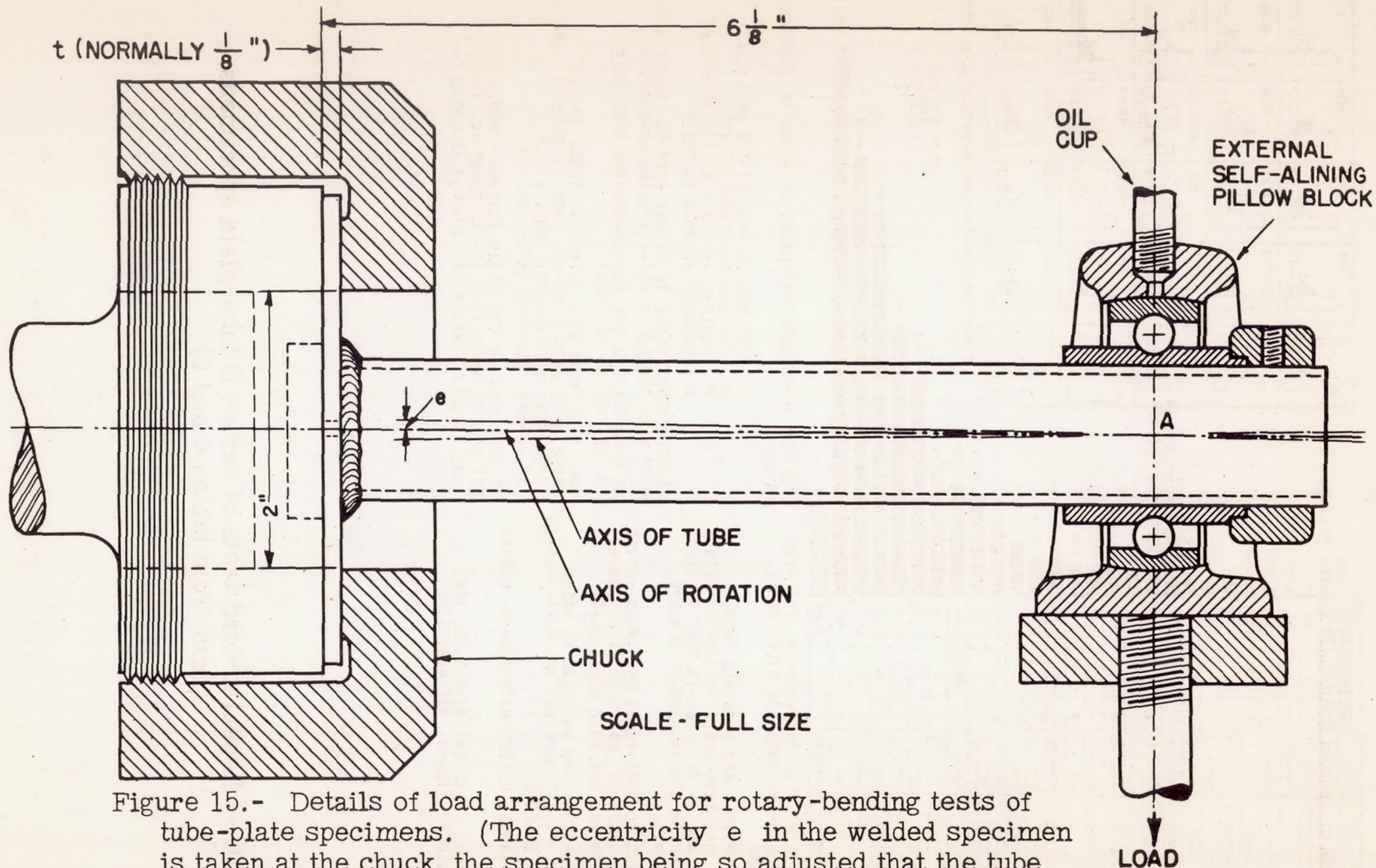
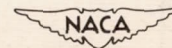
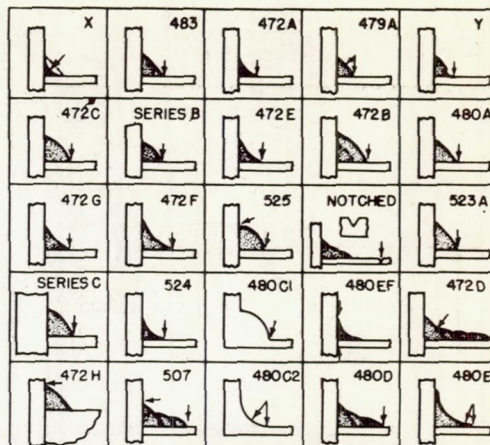

Figure 15.- Details of load arrangement for rotary-bending tests of tube-plate specimens. (The eccentricity e in the welded specimen is taken at the chuck, the specimen being so adjusted that the tube axis intersects the axis of rotation at the plane of application of the load, point A. The normal radius of run-out, or eccentricity, at point A is not greater than 0.005 in.)



WELDING METHOD	DESCRIPTION OF FILLET		HEAT TREATMENT	NO. SPECIMENS	TYPE OF FAILURE	AVERAGE CYCLES TO FAILURE	TEST
	SIZE (IN)	CONTOUR					
METAL-ARC	3/16	FILLET, MACHINED CONCAVE	(16) TABLE 4	3	W	2,200	X
METAL-ARC	1/8	FLAT	ANNEALED	3	T	7,200	483
METAL-ARC	1/8	CONCAVE TO FLAT	NORMALIZED	2	T	7,800	472A
METAL-ARC	3/16	FLAT TO SL CONVEX	NONE	2	T, TW	13,300	479A
METAL-ARC	3/16	MACHINED CONCAVE AT TOE	(17) TABLE 4	2	T	14,000	Y
METAL-ARC	3/16	FLAT TO CONVEX	NORMALIZED	2	T	17,800	472 C
METAL-ARC	3/16	FLAT TO SL CONVEX	(12) TABLE 4	8	T	20,400	SERIES B
GAS	3/16	MODERATELY CONCAVE	NORMALIZED	2	T	21,400	472 E
METAL-ARC	1/4	FLAT TO SL CONVEX, 2-LAYER	NORMALIZED	2	T	22,900	472 B
METAL-ARC	3/16	FLAT	FLAME-SOFT	3	T	22,900	480 A
METAL-ARC	3/16	FLAT TO CONCAVE	NORMALIZED	2	T	23,600	472 G
GAS	1/4	MODERATELY CONCAVE	NORMALIZED	2	T	29,200	472 F
METAL-ARC	3/16	FULLY CONVEX	NONE	3	P, T, TP	29,900	525
CIRCUMFERENTIAL V NOTCH IN TUBE 0.03" DEEP			NORMALIZED	2	NOTCH	34,600	0.03" NOTCH
METAL-ARC	3/16	FLAT (25-20 WELD)	NONE	3	T	37,200	523 A
METAL-ARC	7/16	FLAT TO SL CONVEX	NONE	6	T	49,300	SERIES C
METAL-ARC	1/4	FULLY CONVEX	NONE	3	T	67,600	524
MACHINED	0.25	FULLY CONVEX (NO WELD)	NORMALIZED	1	T	91,000	480 G1
BRAZE	1/8	FULLY CONVEX	NONE	3	BT, BT, B	103,100	480EF
ARC+GAS	3/16 x 3/16	ARC+3-LAYER GAS WELD	NORMALIZED	2	W	120,000	472 D
METAL-ARC	3/16	FLAT (SOLID BAR)	NORMALIZED	2	P	202,000	472 H
METAL-ARC	3/16 x 3/16	TAPERED, FLAT, 3-LAYER	NORMALIZED	3	P, T, T	250,000	507
MACHINED	0.25	FULLY CONVEX (NO WELD)	NORMALIZED	1	TW	354,000	480 C2
GAS	3/16 x 3/16	TAPERED, FLAT, 3-LAYER	NORMALIZED	3	T	403,700	480 D
BRAZE	1/8	MOD. TO FULLY CONVEX	NONE	1	T	506,000	480 E
BASIC FORGED AND MACHINED SPECIMEN			NORMALIZED	1	T	99,000	

Datum: 99,000 cycles for basic specimen



TYPICAL SECTIONS THROUGH CIRCUMFERENTIAL FILLETS

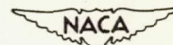

ALL SPECIMENS MADE WITH 1- BY 0.065-IN. SAE 4130 STEEL TUBING AND 1/8-IN. SAE 4130 STEEL PLATE, EXCEPT AS FOLLOWS:

BASIC SPECIMEN - FORGED AND MACHINED FROM SAE 4140 STEEL TO 1/8-IN. FLANGE AND 1- BY 0.065-IN. TUBE SECTION, WITH 1/4-IN. SMOOTH CONCAVE FILLET

SERIES C - ARC-WELDED TUBE-PLATE SPECIMENS, USING 1- BY 0.095-IN. SAE 4130 STEEL TUBING AND 1/4-IN. SAE 4130 STEEL PLATE

480C2 - SAME DIMENSIONS AND MATERIAL AS BASIC SPECIMEN, EXCEPT MACHINED AND HEAT-TREATED IN ANOTHER GROUP

480C1 - SAME AS 480C2, EXCEPT WITH 1/4-IN. CONVEX FILLET

472H - SOLID 1-IN. ROUND SAE 4130 STEEL BAR, ARC-WELDED TO 1/8-IN. SAE 4130 STEEL PLATE

LOCATION OF FAILURE INDICATED BY ARROW IN SKETCHES ABOVE:

- T FAILURE IN TUBE AT TOE OF FILLET
- W FAILURE IN THROAT OF WELD
- P FAILURE IN PLATE AT TOE OF FILLET
- B FAILURE IN BOND TO PLATE

ALL SPECIMENS TESTED IN ROTARY BENDING EXCEPT 479A WHICH WERE TESTED IN AXIAL TENSION-COMPRESSION.

THE LOAD USED IN THE ROTARY-BENDING TEST (SEE FIG. 15) WAS AS FOLLOWS:

ALL SPECIMENS WITH 0.065-IN. TUBE, 147 LB SPECIMENS WITH 0.095-IN. TUBE (SERIES C), 196 LB SPECIMENS WITH NOTCHED TUBE, 67 LB SOLID-BAR SPECIMENS (472H), 147 LB

THE LOAD USED IN THE AXIAL TENSION-COMPRESSION TEST OF SPECIMENS 479A (1- BY 0.065-IN. TUBE) WAS 4100-LB TENSION AND 4700-LB COMPRESSION

Figure 16.- Repeated-load tests of series D tube-plate specimens. (Data from tables 4 and 9)

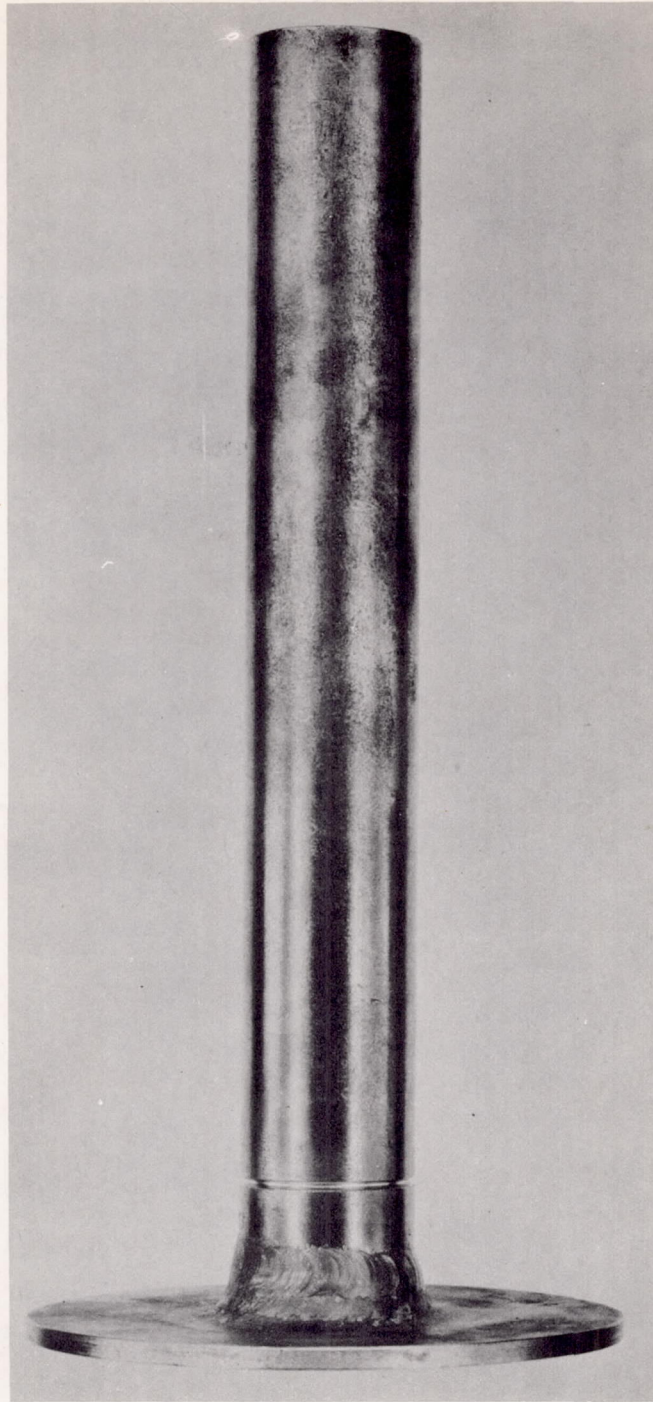
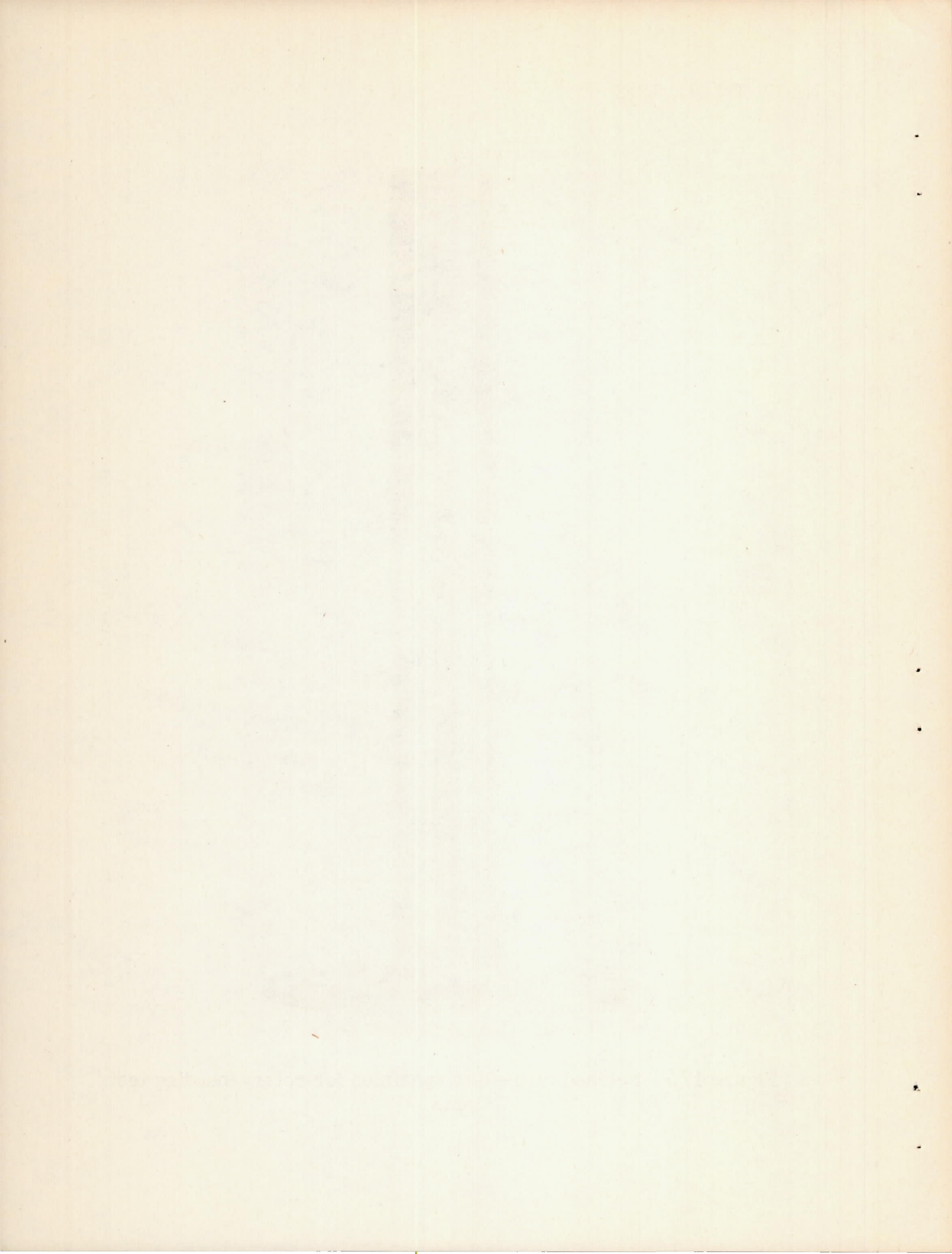

Figure 17.- Notched tube-plate specimen for rotary-bending test.



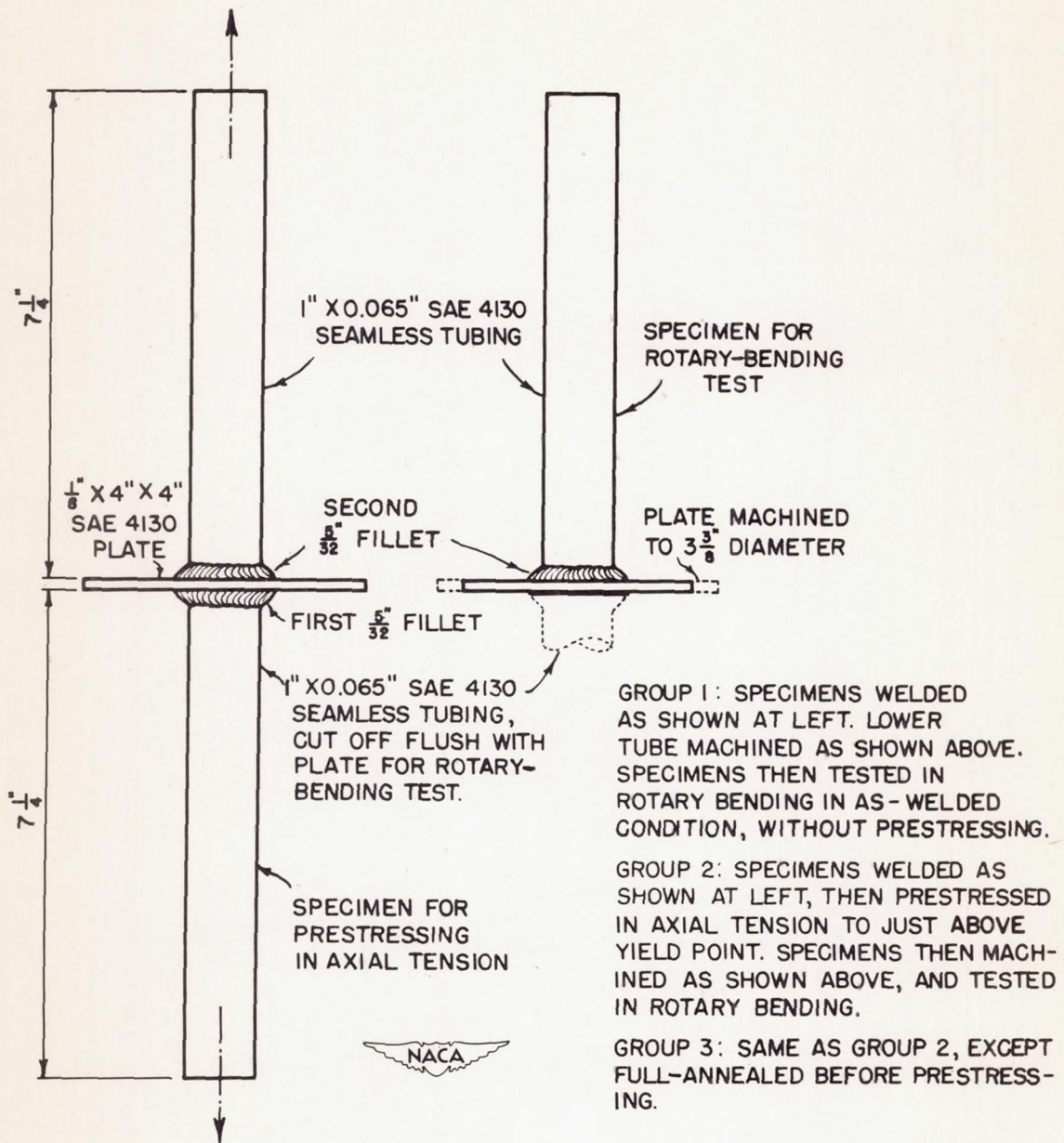
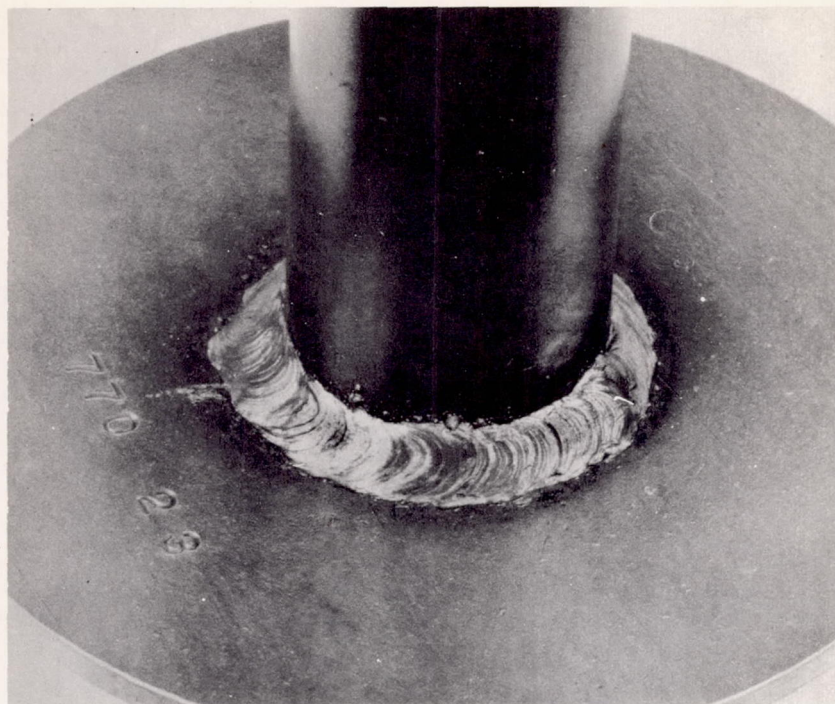
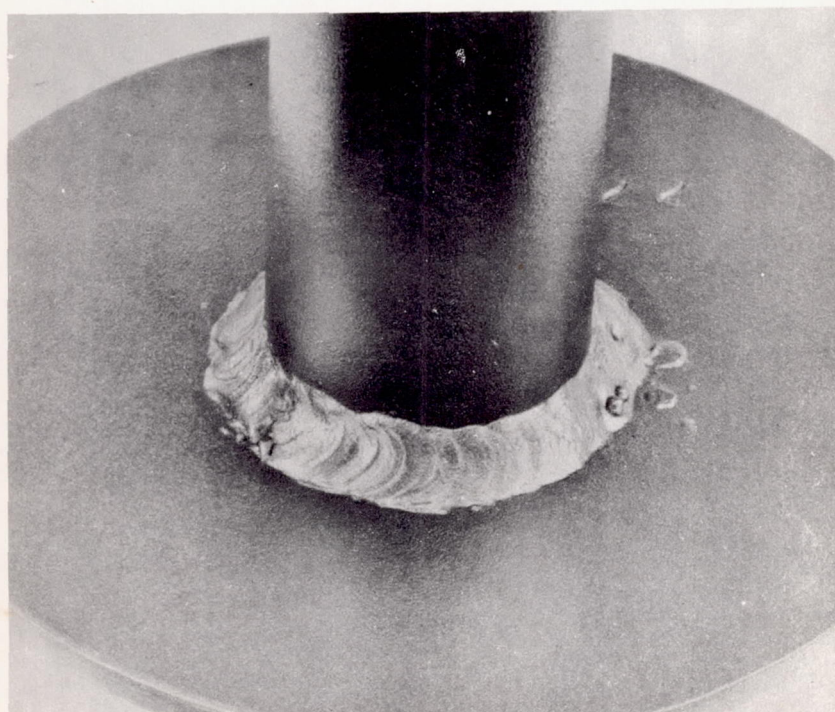

Figure 18.- Tube-plate specimen for rotary-bending test after prestressing in axial tension.



(a) As welded.



(b) Shot-peened.

Figure 19.- Metal-arc-welded tube-plate specimens for shot-peening test.

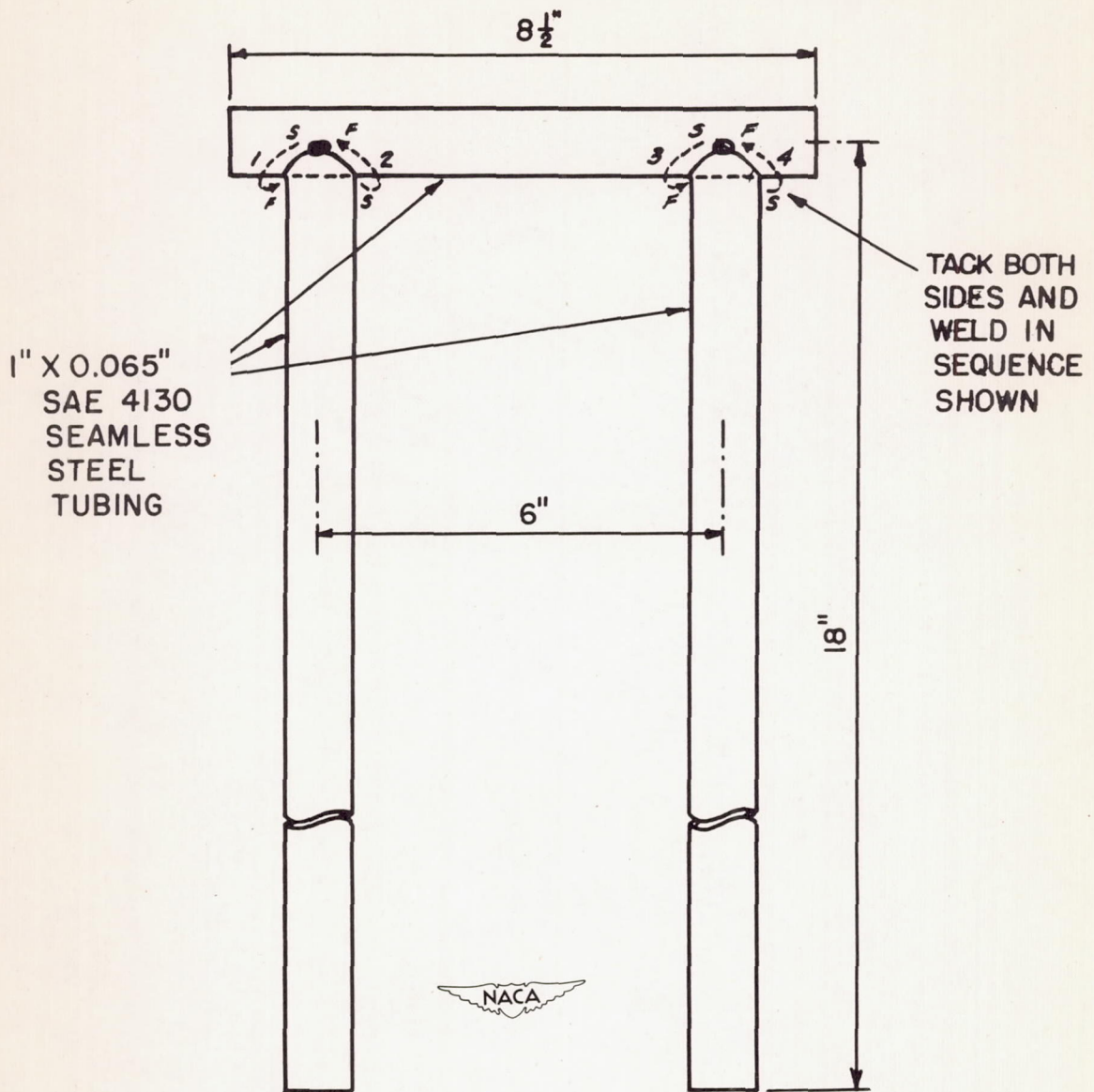

Figure 20.- Metal-arc-welded tubular pi specimen, series H, for reversed-bending fatigue test.

1870
1871
1872
1873



1874
1875
1876
1877

1878
1879
1880
1881

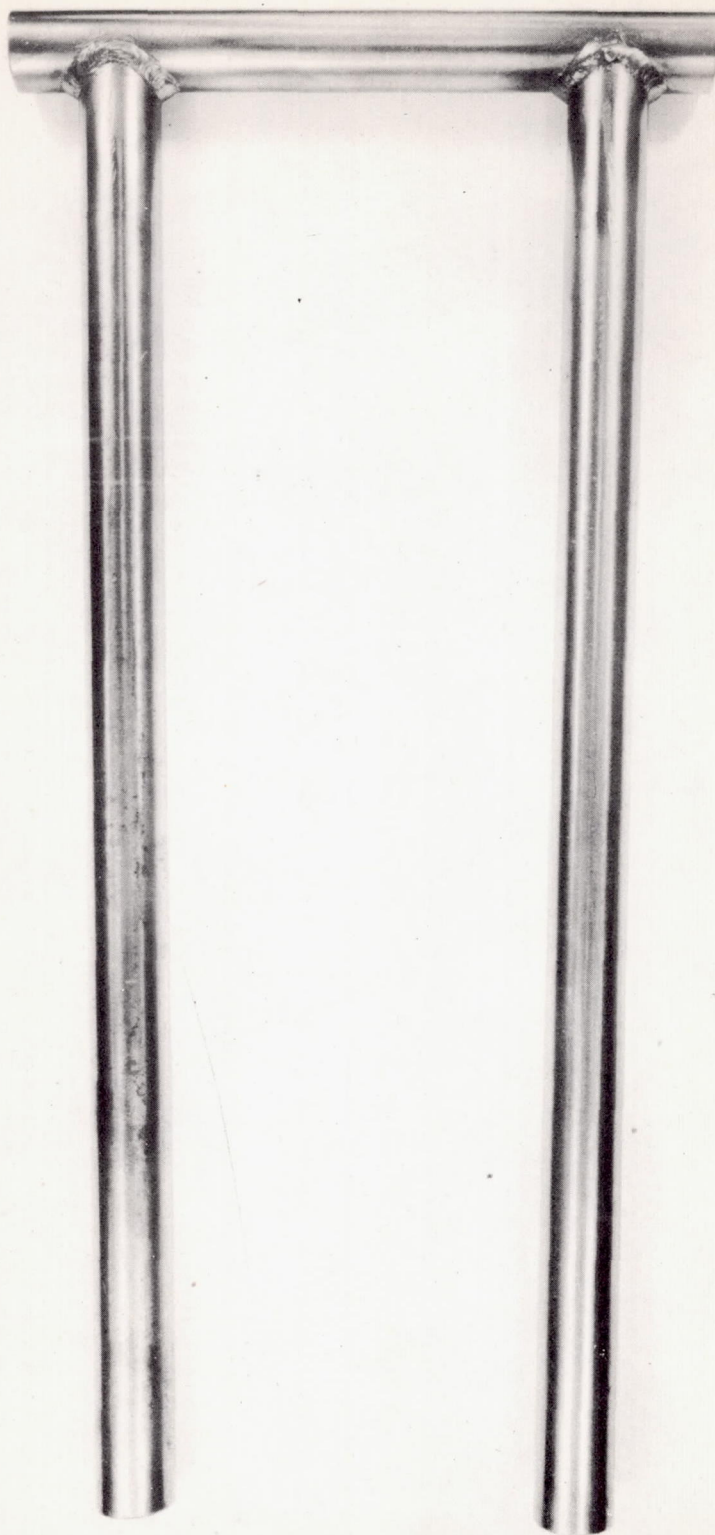
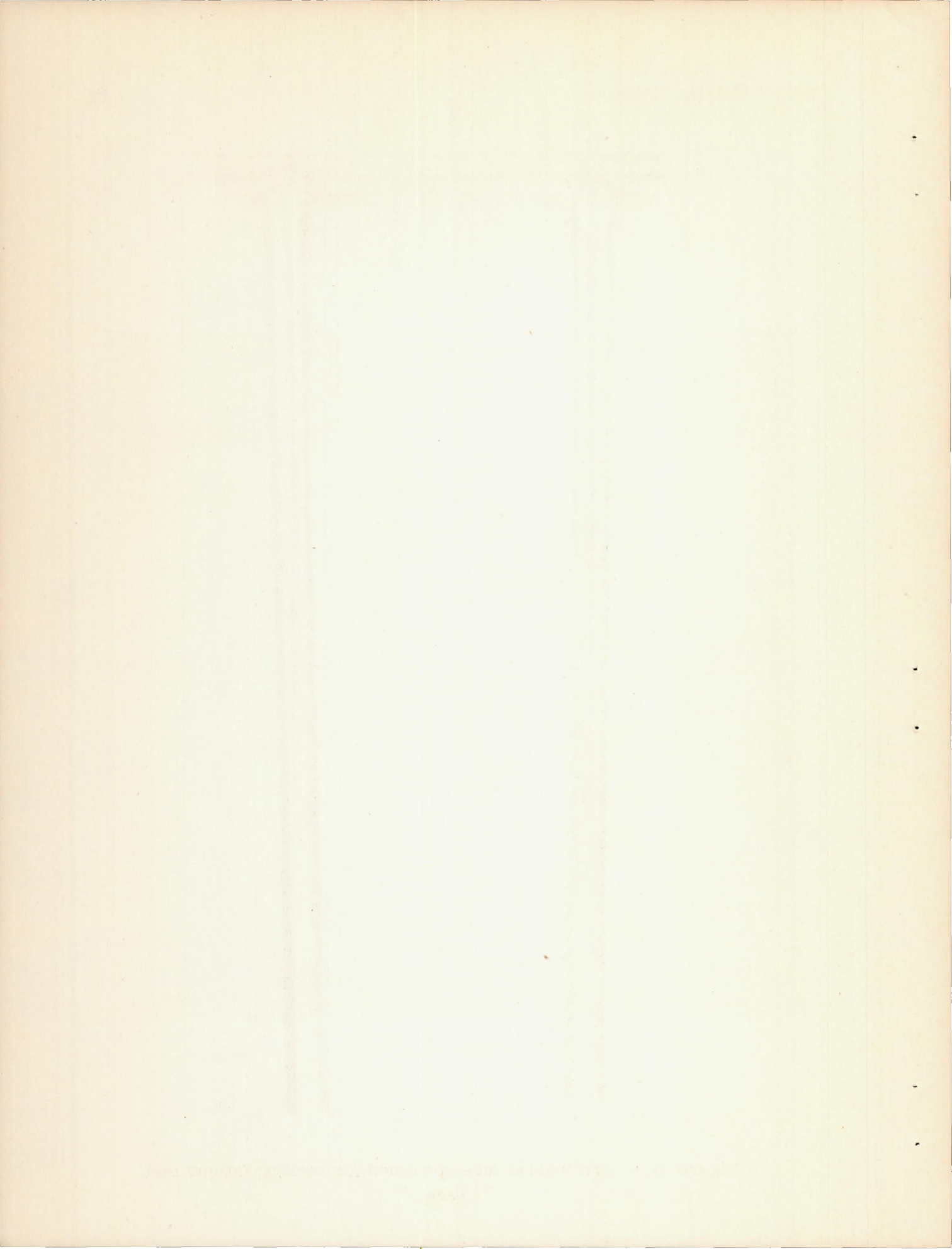

Figure 21.- Arc-welded tube specimen for bending fatigue test.



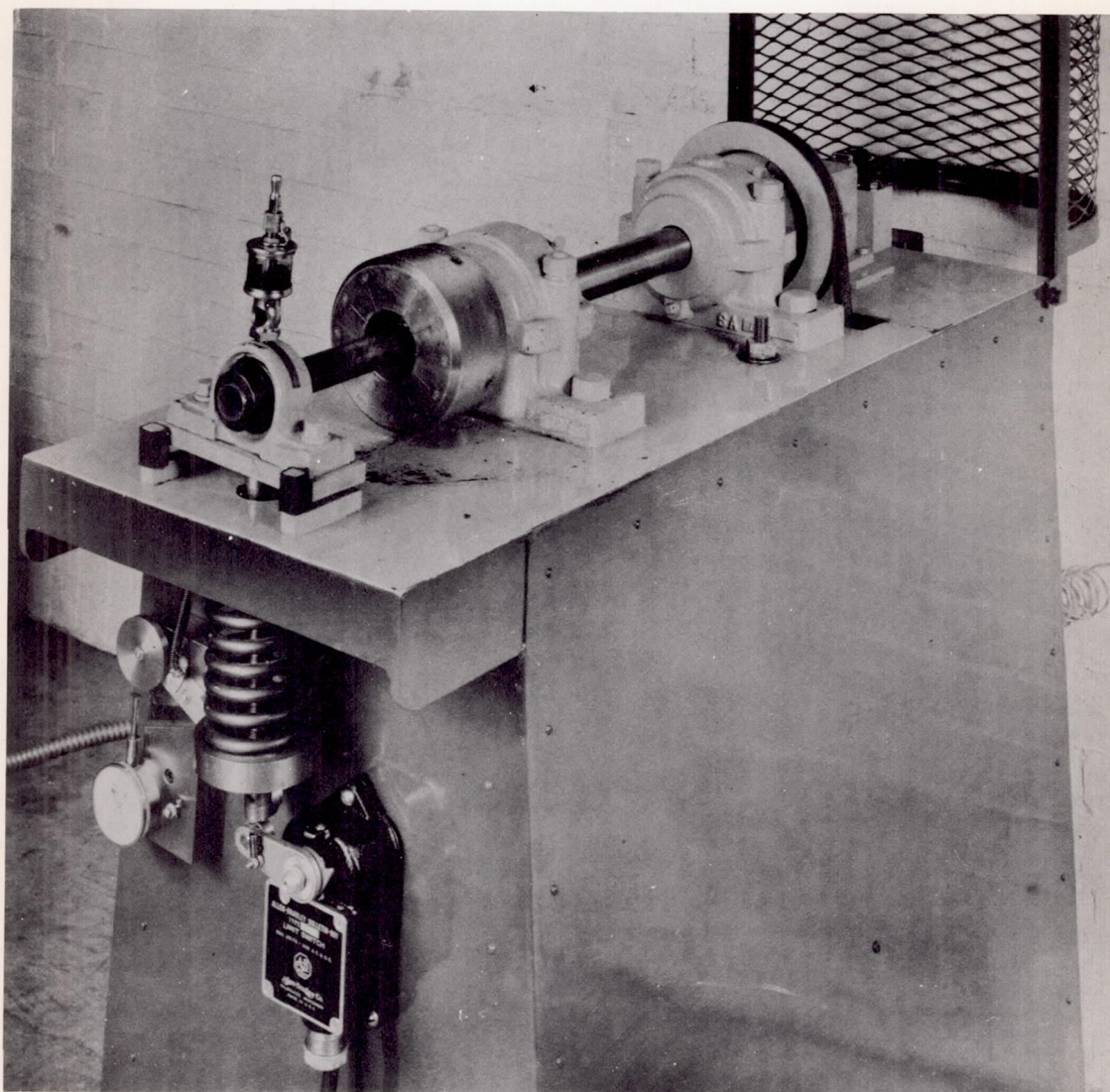
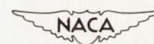

Figure 22.- Rotary-bending testing machine.



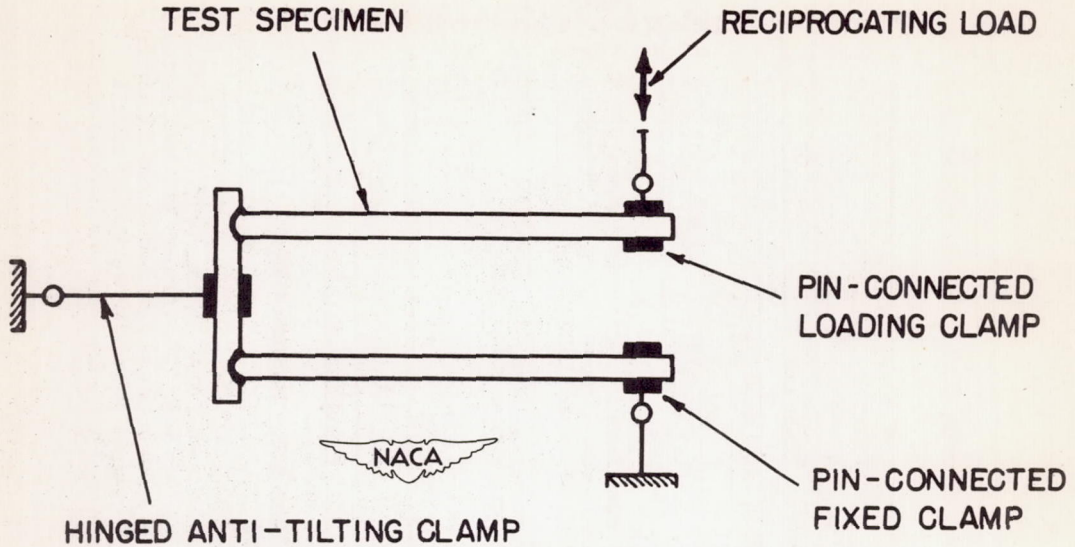

Figure 23.- Schematic diagram of method of loading tubular pi specimens, series H, to produce reversed bending stress (maximum at weld joints). (For specimen dimensions see fig. 20.)

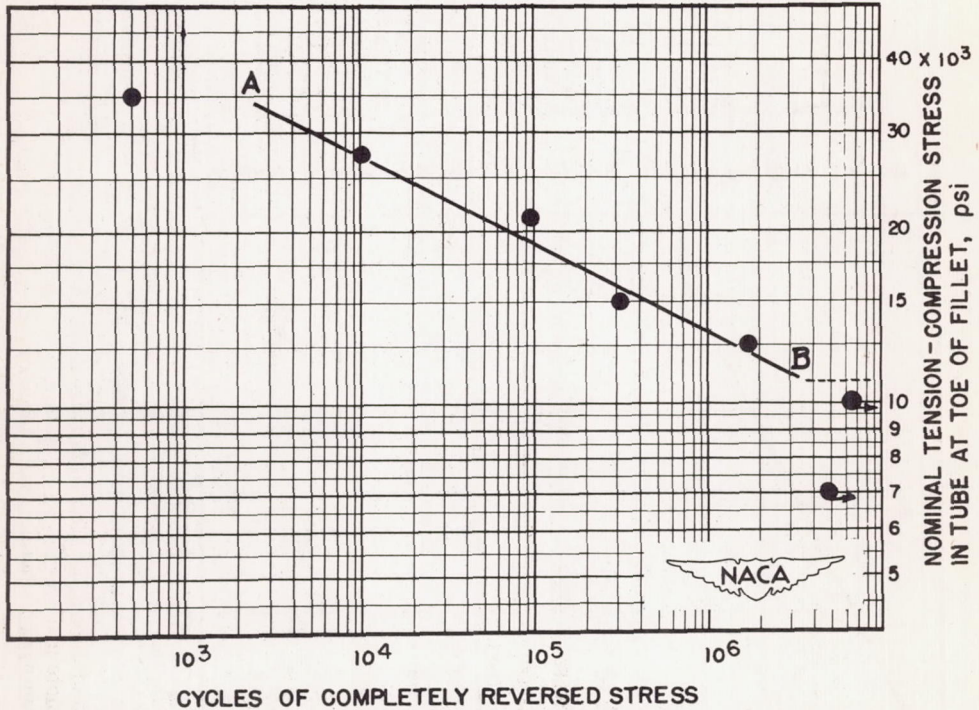

Figure 24.- Rotary-bending tests of tube-plate specimens forged and machined from solid bar, series A, for use as an arbitrary standard for comparison of the fatigue strength of welded and notched tube-plate specimens in series B, C, D, E, F, and G. (See fig. 25 for explanation of use of the standard.) Standard specimens made from solid SAE 4140 steel forgings; machined to dimensions shown in figure 1 with a 1/4-inch smooth concave fillet; tested after normalizing.

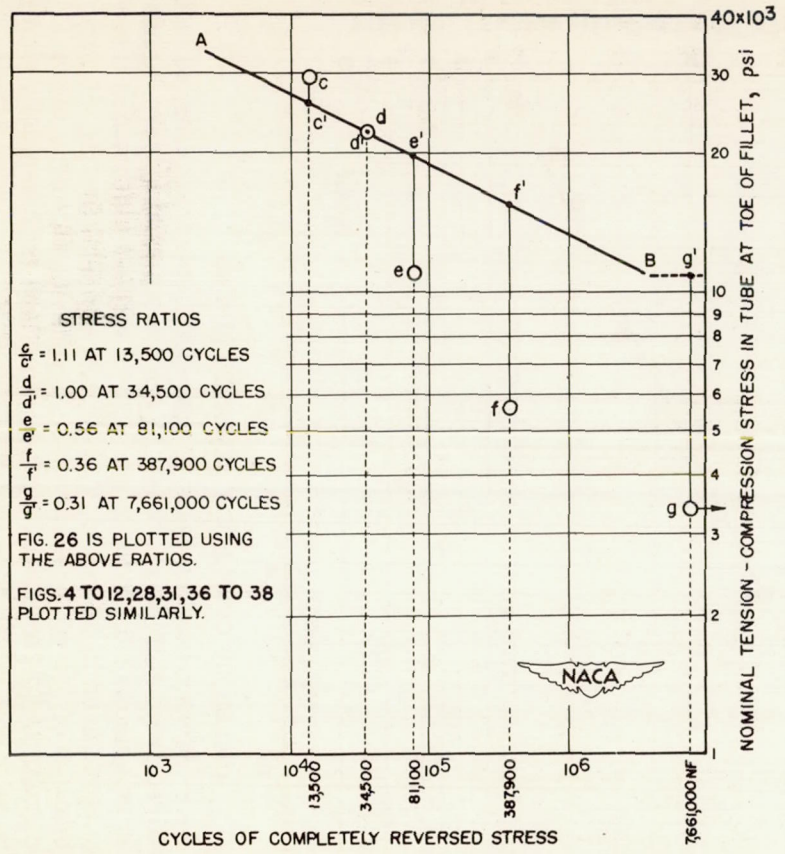

Figure 25.- Method of computing ratio of fatigue strength of welded to machined tube-plate specimens. (Line Ac'd'e'f'Bg' is S-N curve for machined specimens. (See fig. 24.) Points c, d, e, f, and g are individual S-N values for a group of arc-welded specimens.)

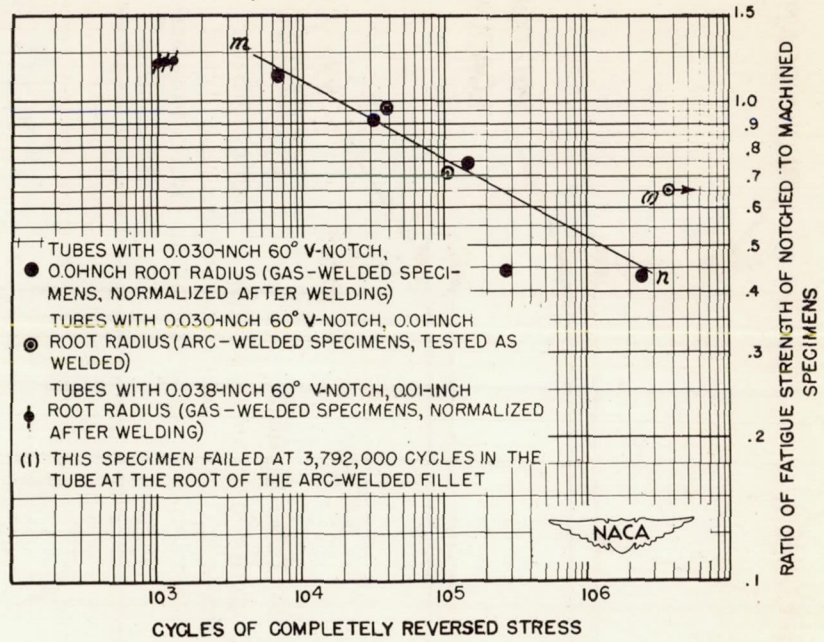

Figure 26.- Rotary-bending tests of notched tube-plate specimens, series E. Comparison of strength relative to an arbitrary standard machined from solid bar. Tubing, 1- by 0.065-inch SAE 4130; plate, 1/8-inch SAE 4130; notch, as indicated in graph. (Line mn is used as a datum line in figs. 4 to 12, 28, 31, and 36 to indicate the relative strength of welded and notched specimens with reference to the arbitrary standard machined from solid bar.)

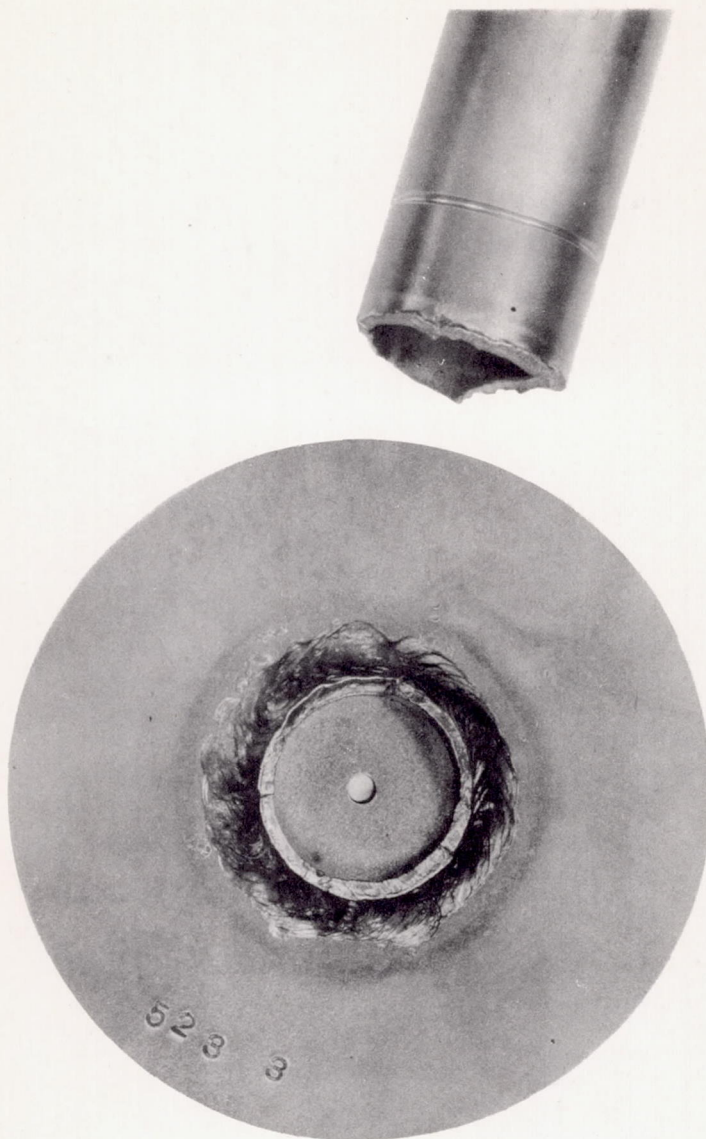
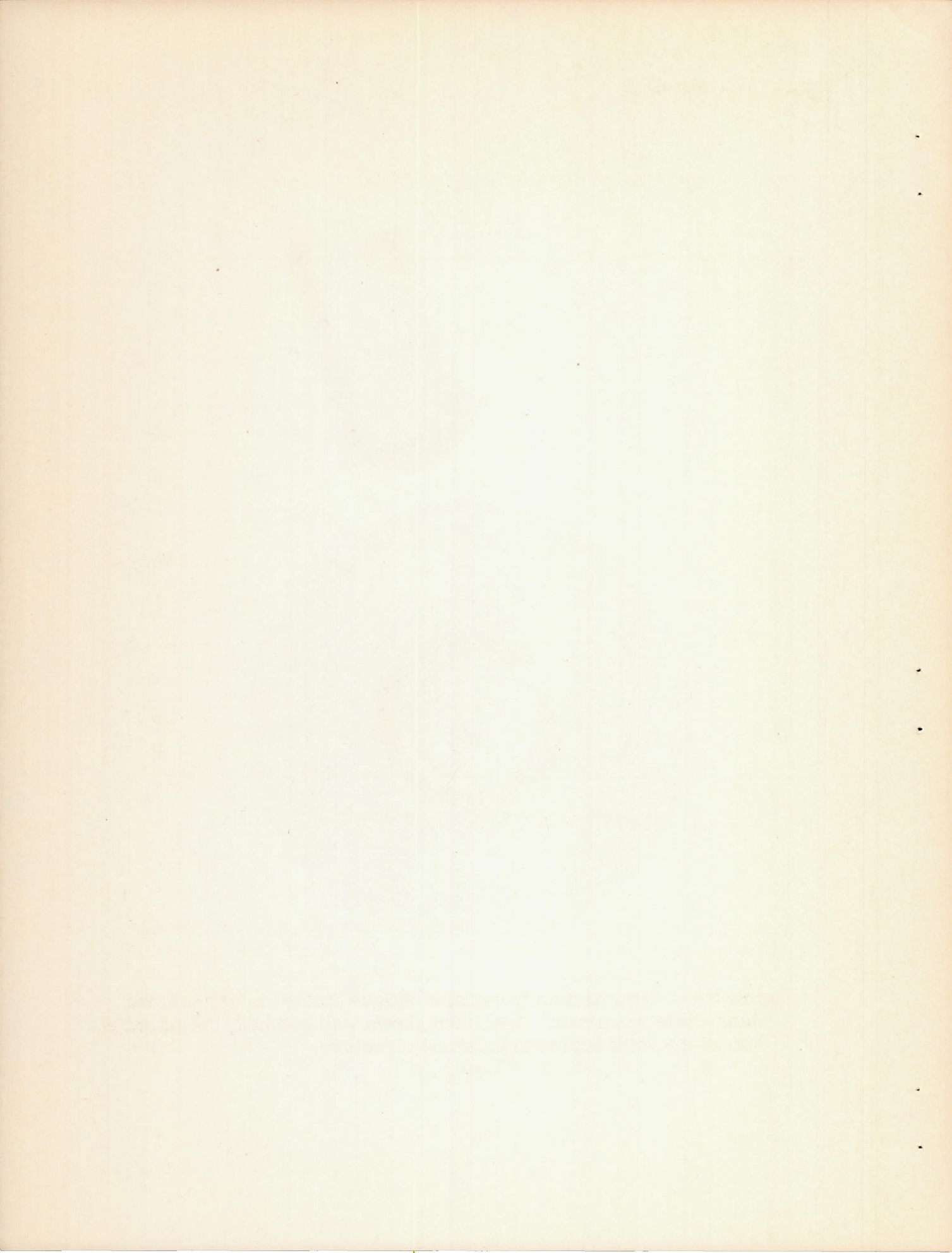

Figure 27.- Typical rotary-bending fatigue failure in arc-welded tube-plate specimen. Specimen shown was notched, but failed at toe of the weld with characteristic fracture.



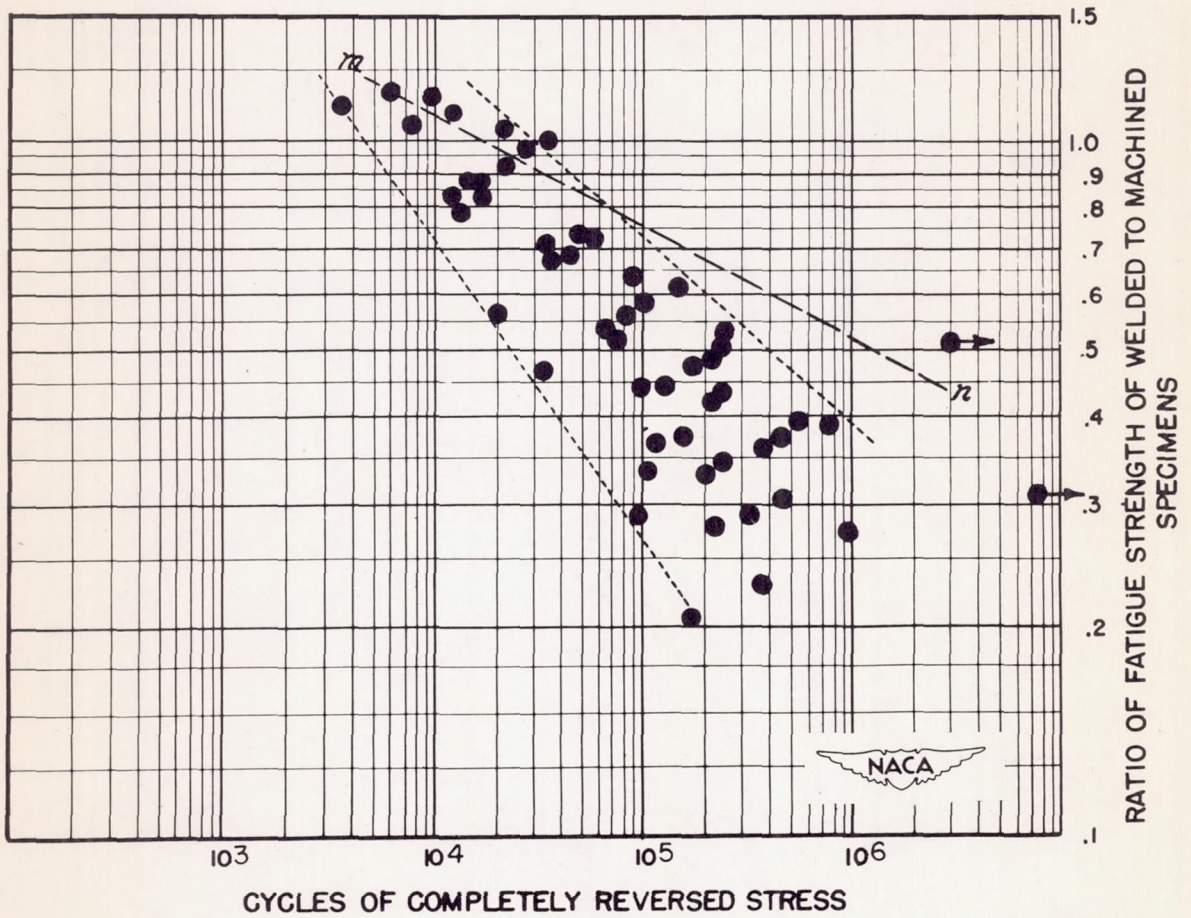
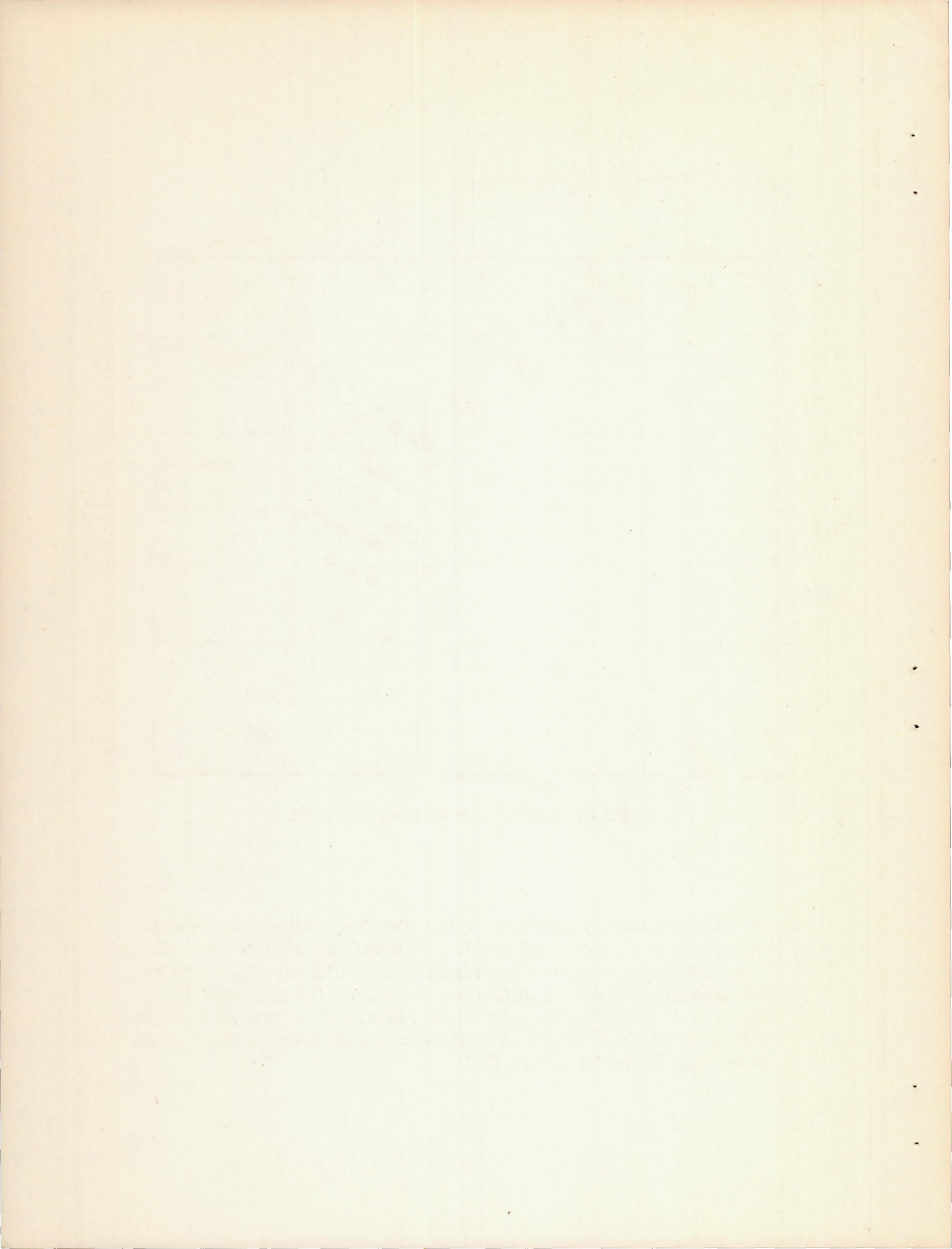
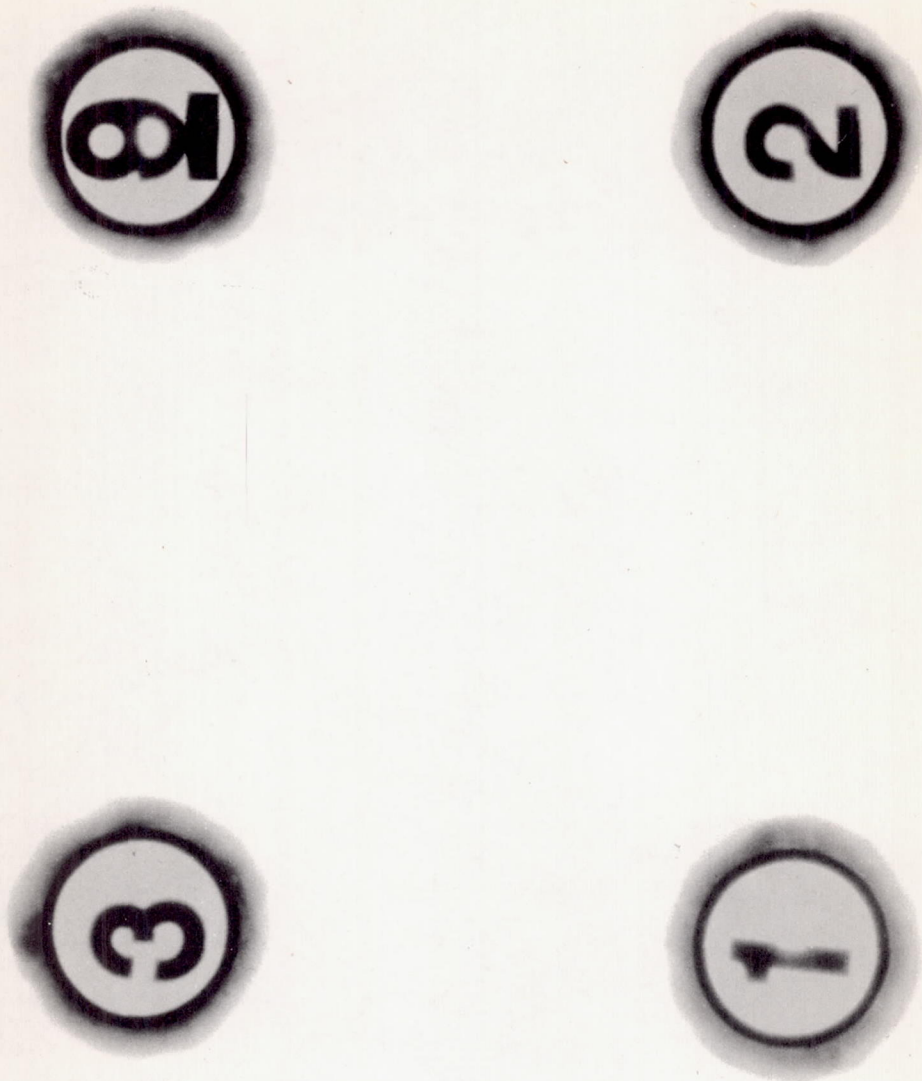

Figure 28.- Summary graph of rotary-bending tests of arc-welded tube-plate specimens, series B. Comparison of strength relative to an arbitrary standard machined from solid bar. Electrodes, carbon and alloy steel; initial temperature, 70° and 300° F; tubing, 1- by 0.065-inch SAE 4130; plate, 1/8-inch SAE 4130; weld, 5/32 inch with 45° fillet; miscellaneous heat treatments. (Data from table 7 and figs. 4 to 12.)





Preheat 70° F

Preheat 300° F

Figure 29.- Radiographs of series B tube-plate fillet welds made with 5/64-inch Wilson 520 electrodes (plain-carbon steel).

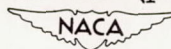

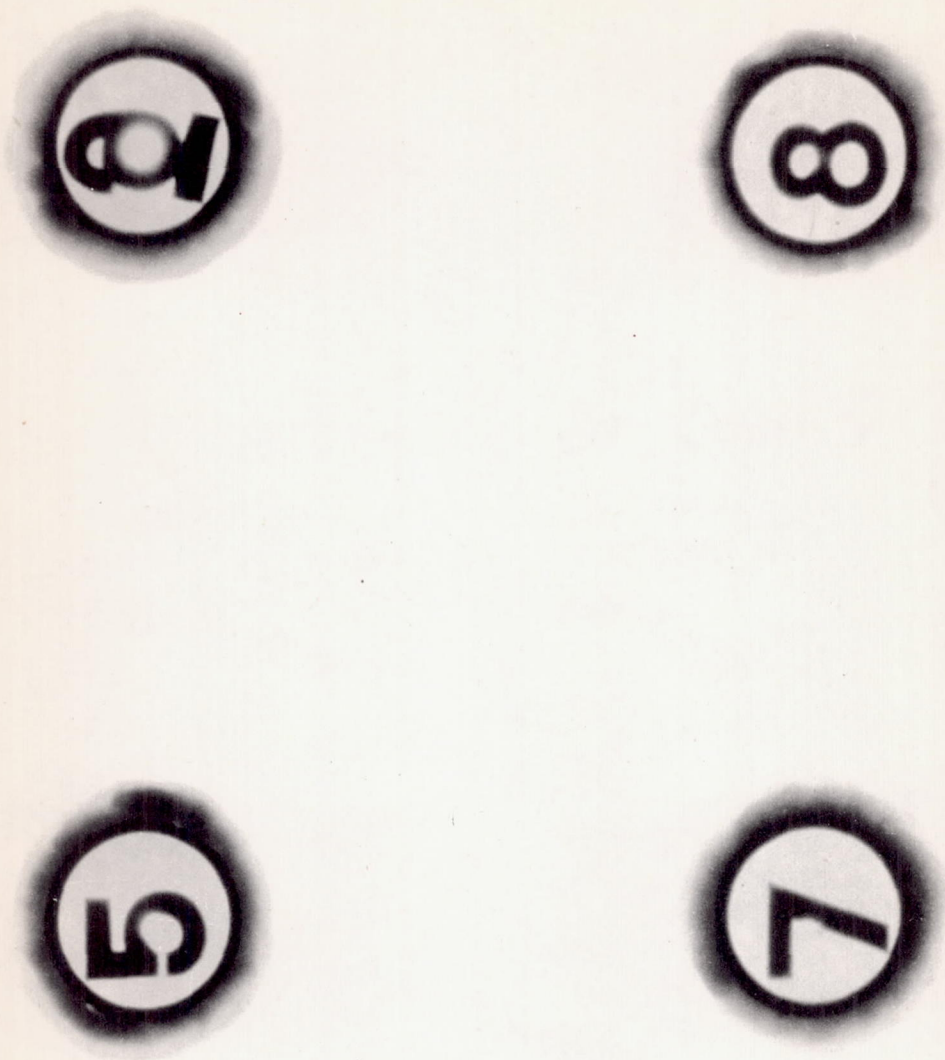

Preheat 70° F

Preheat 300° F

Figure 30.- Radiographs of series B tube-plate fillet welds made with 5/64-inch Lincoln Planeweld 1 electrodes (alloy-steel deposit).





Faint, illegible text or markings at the bottom of the page, possibly bleed-through from the reverse side.

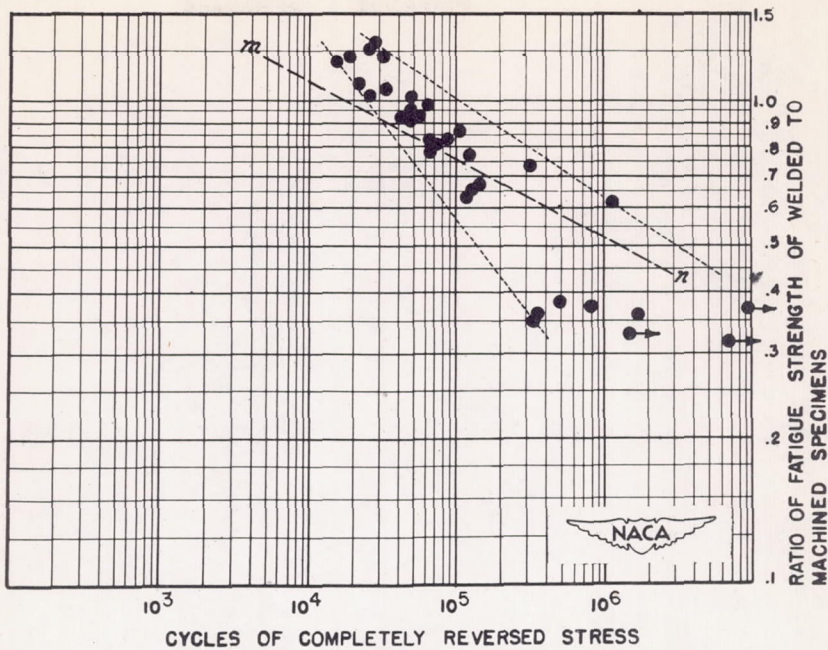

Figure 31.- Summary graph of rotary-bending tests of arc-welded tube-plate specimens, series C. Comparison of strength relative to an arbitrary standard machined from solid bar. Electrodes, carbon and alloy steel; initial temperature, 70° F; tubing, 1- by 0.095-inch SAE 4130; plate, 1/4-inch SAE 4130; weld, 7/32 inch with 45° normal fillet; tested as welded. (Data from table 8.)

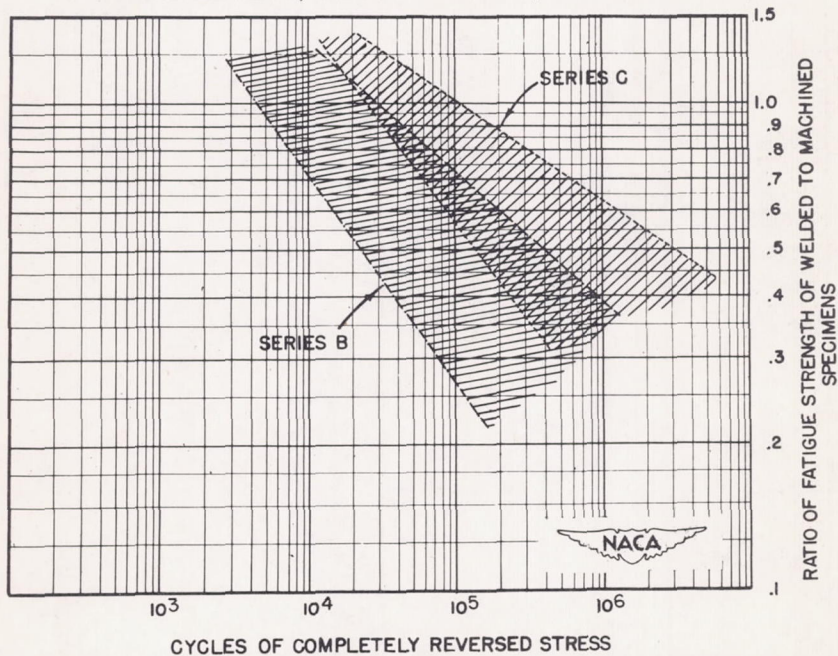
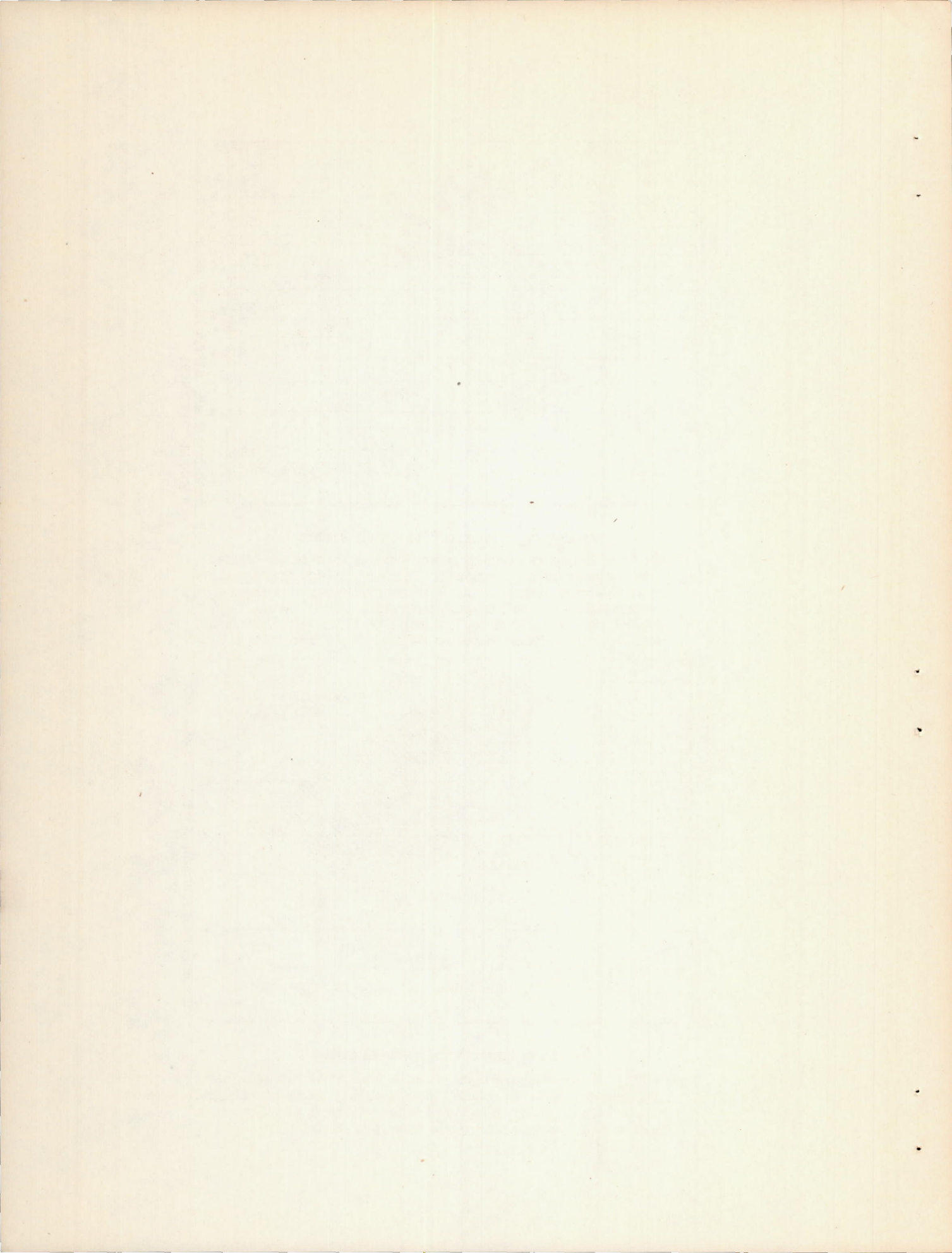

Figure 32.- Rotary-bending tests of arc-welded tube-plate specimens. Comparison of strength relative to an arbitrary standard machined from solid bar. Relative extent of fatigue-strength zones of series B and series C specimens. (Data from figs. 28 and 31.)



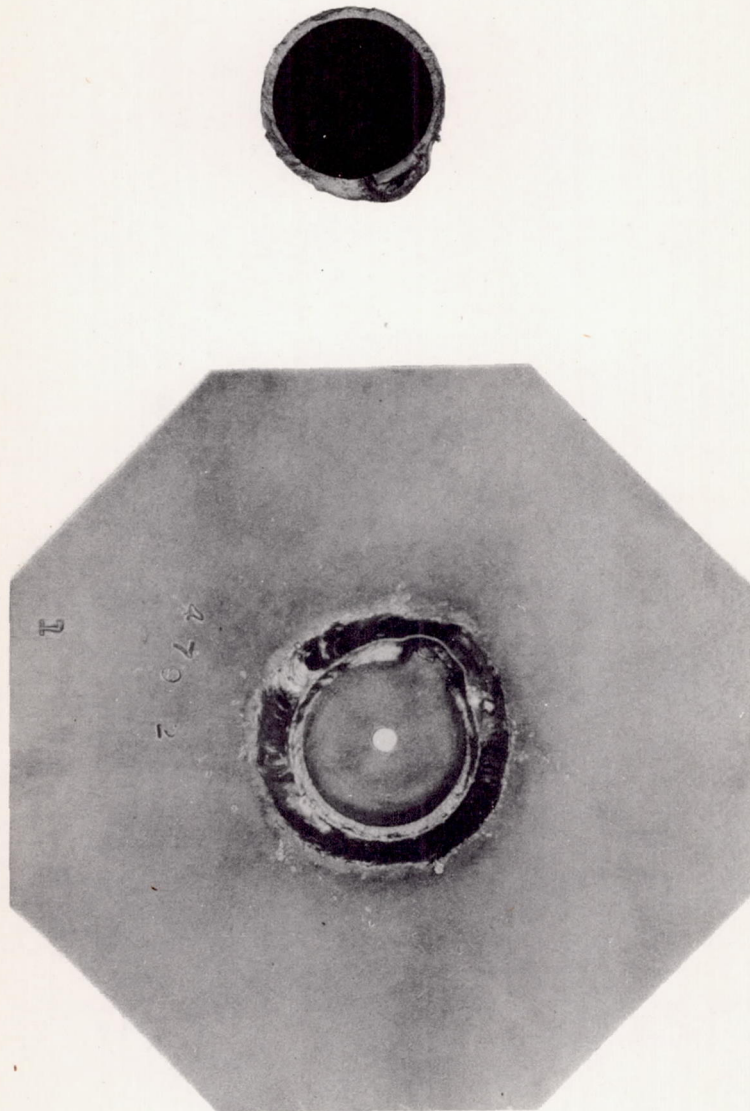

Figure 33.- Fracture in axial-tension-compression plate-tube-plate specimen. Greater part of fracture in tube at toe of fillet weld.

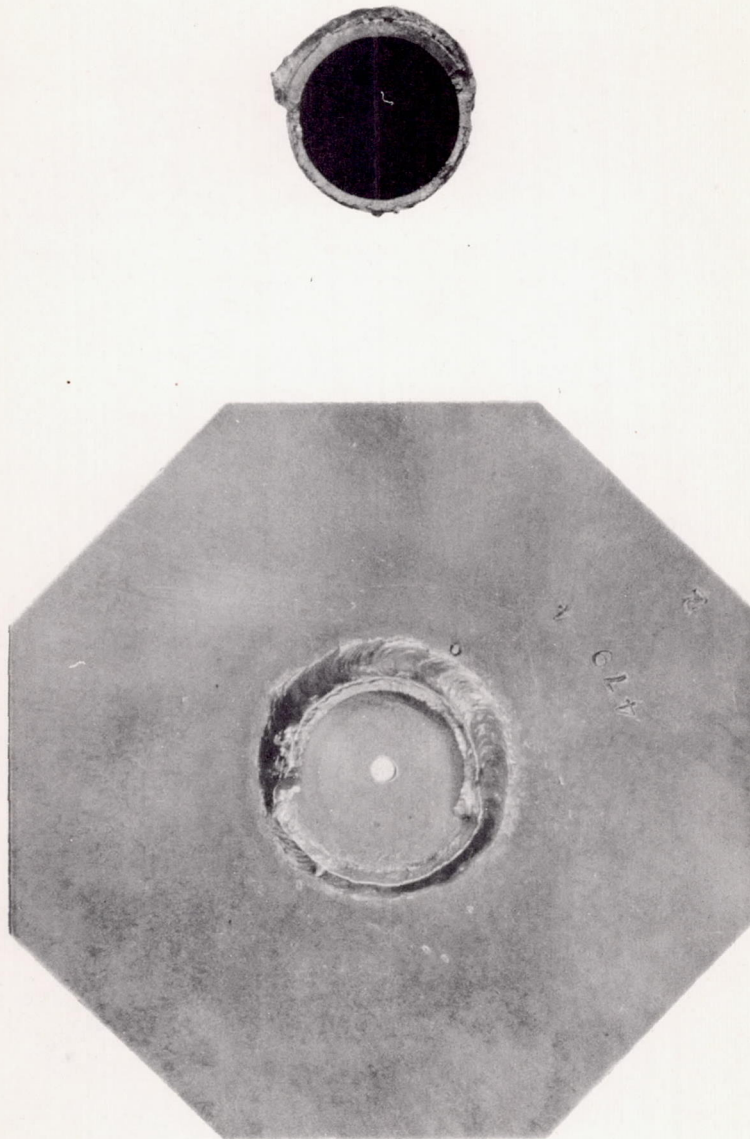

Figure 34.- Fracture in axial-tension-compression plate-tube-plate specimen. Fracture half in tube at toe of fillet, and half through throat of fillet.

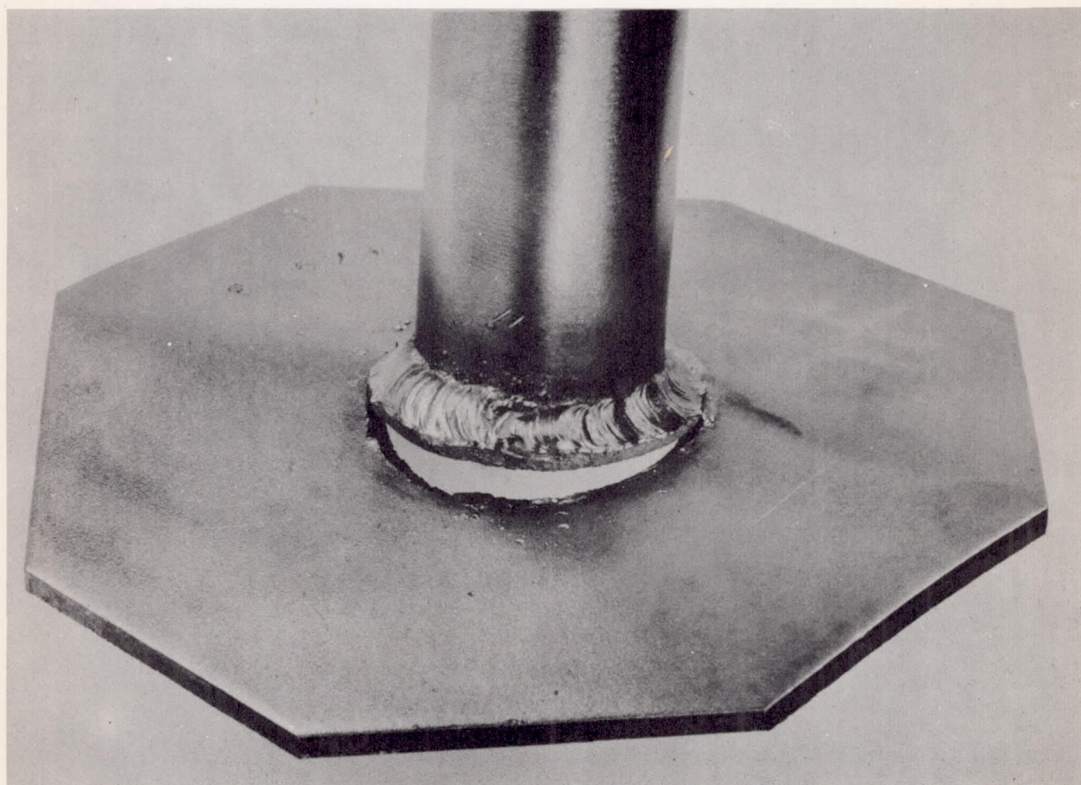
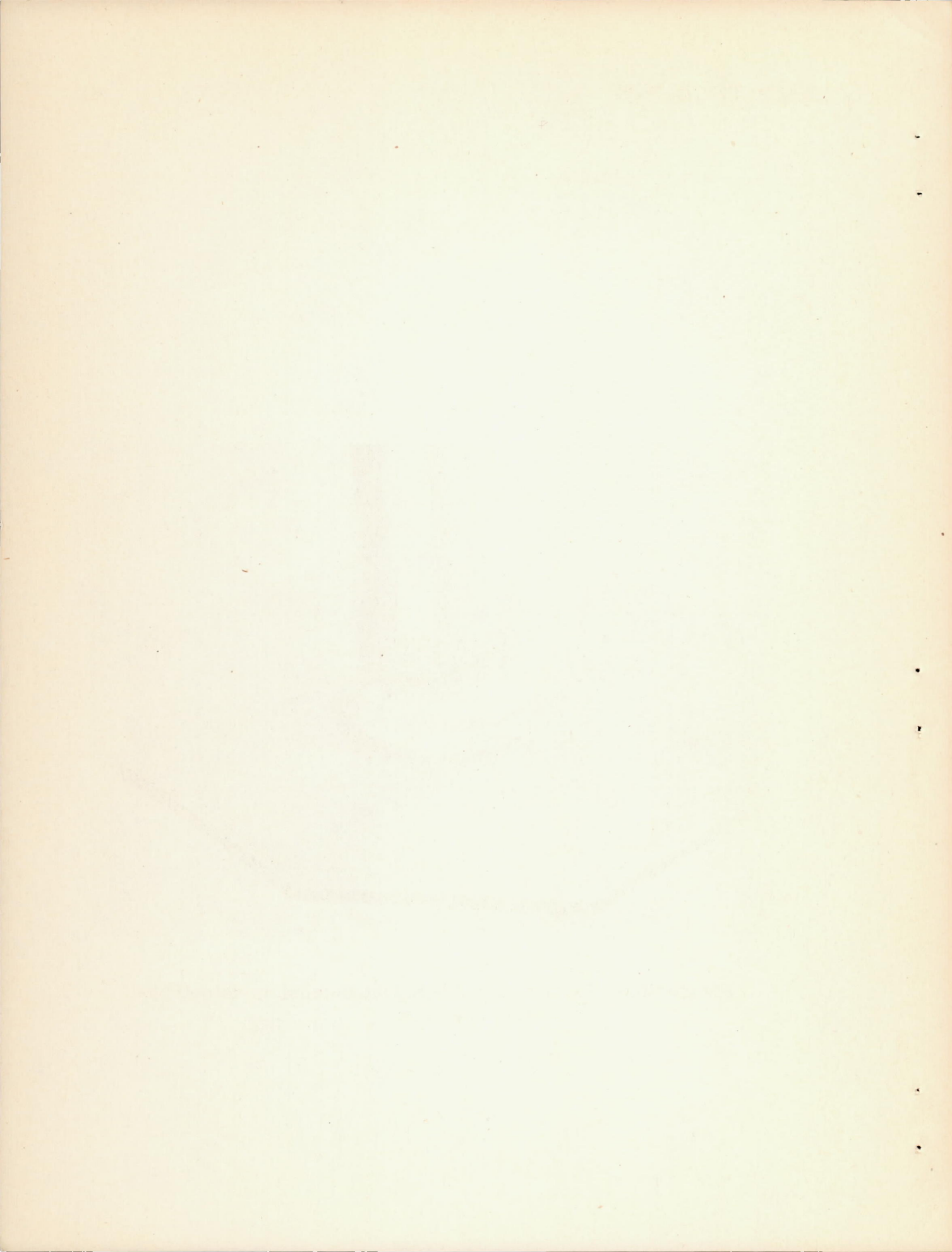

Figure 35.- Failure in axial-repeated-tension plate-tube-plate specimen.





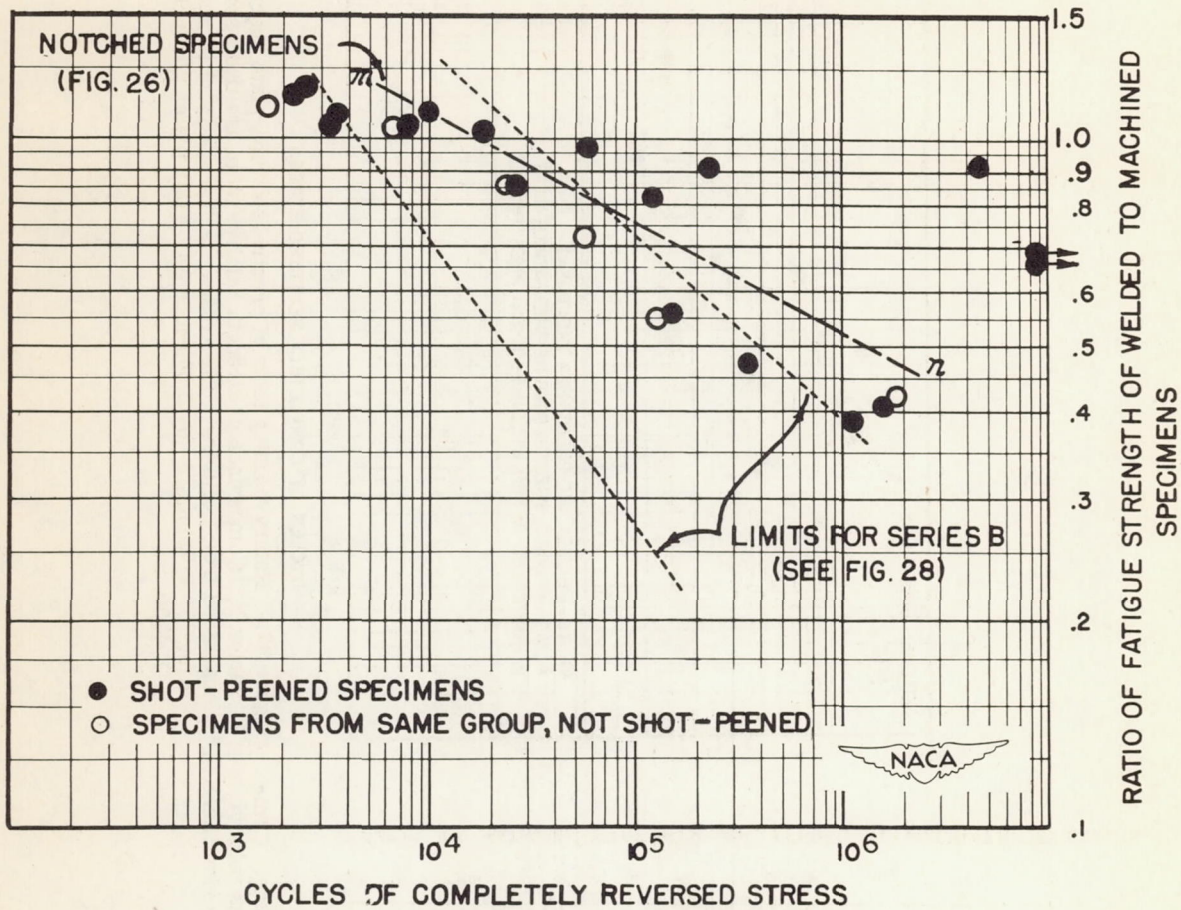

Figure 38.- Rotary-bending tests of shot-peened tube-plate specimens, series G. Comparison of strength relative to an arbitrary standard machined from solid bar. Electrodes, carbon steel; initial temperature, 70° F; tubing, 1- by 0.065-inch SAE 4130; plate, 1/8-inch SAE 4130; no heat treatment after welding.

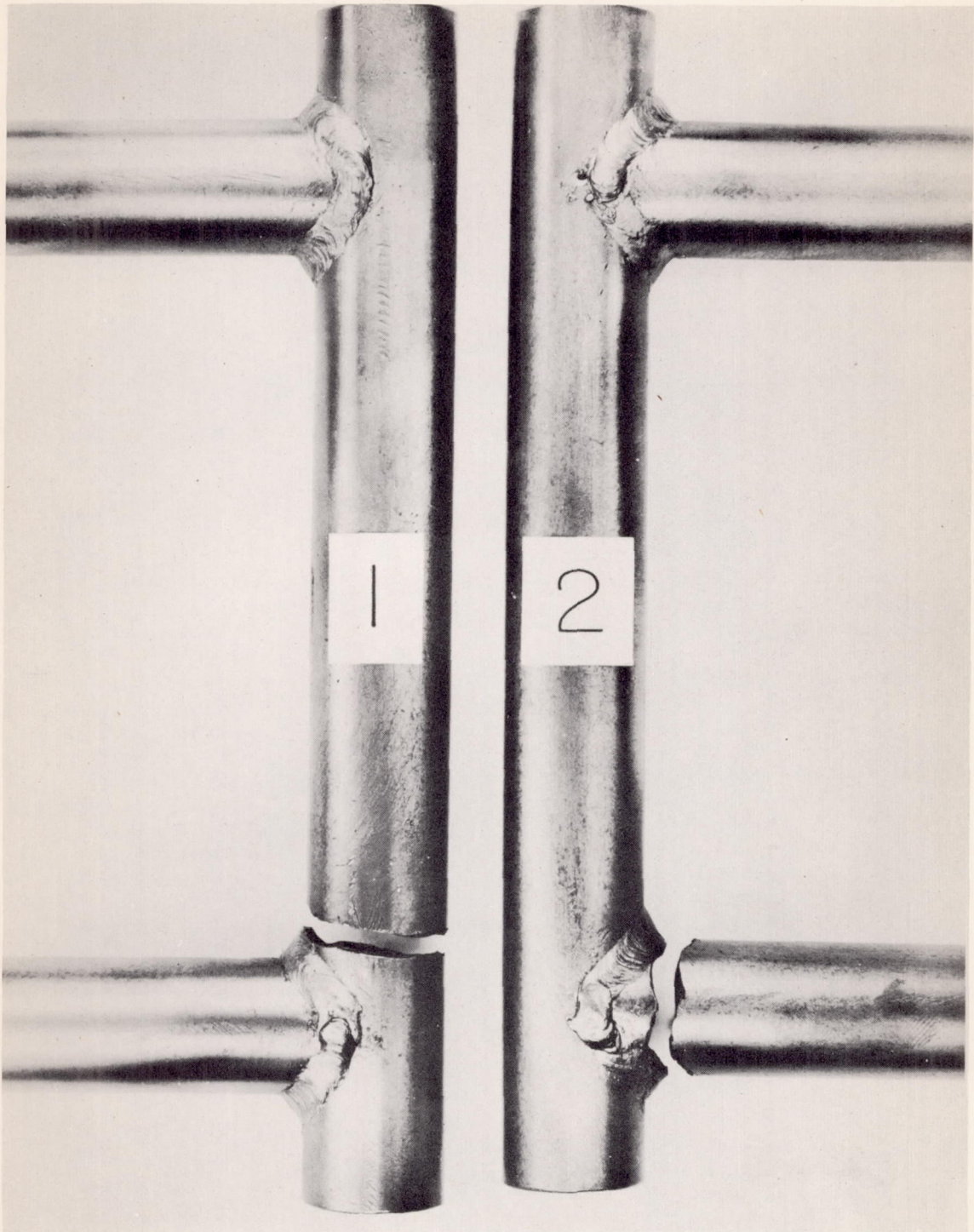

Figure 39.- Typical fatigue failures in metal-arc-welded pi specimens.

