

NACA TN 1335

NATIONAL ADVISORY COMMITTEE FOR AERONAUTICS

TECHNICAL NOTE

No. 1335

THE LOCAL BUCKLING STRENGTH OF LIPPED Z-COLUMNS
WITH SMALL LIP WIDTH

By Pai C. Hu and James C. McCulloch

Langley Memorial Aeronautical Laboratory
Langley Field, Va.



Washington

June 1947

REPRODUCED BY
NATIONAL TECHNICAL
INFORMATION SERVICE
U.S. DEPARTMENT OF COMMERCE
SPRINGFIELD, VA. 22161

NATIONAL ADVISORY COMMITTEE FOR AERONAUTICS

TECHNICAL NOTE NO. 1335

THE LOCAL BUCKLING STRENGTH OF LIPPED Z-COLUMNS

WITH SMALL LIP WIDTH

By Pai C. Hu and James C. McCulloch

SUMMARY

A method is presented for calculating the local buckling strength of lipped Z-columns with small lip width, and some experimental data are presented showing the agreement between theoretical and experimental results.

INTRODUCTION

For the construction of stiffened compression panels, Z-section stiffeners are frequently used. For the calculation of the local buckling strength of these compression panels, a method employing some of the principles of moment distribution is in common use. The critical stresses calculated by this method agree well with experimental critical stresses for most dimension ratios. If, however, the flange width is very small as compared to the web width, this method breaks down and the experimental critical stresses fall below the theoretical values. As a consequence, a different theory must be developed to cover these proportions.

Figure 1 shows a Z-stiffened panel. One stiffener can be reversed, as indicated in the figure, without affecting the local buckling strength of the panel. If this stiffener is reversed, a section similar to a lipped Z-column is obtained. Since the physical action of the lipped Z-column is similar to action of the Z-stiffened panel and the cost of the lipped Z-column specimens is less than that of Z-stiffened panels, tests were made of lipped Z-columns in order that the theory presented herein may be reasonably substantiated before it is applied to Z-stiffened panels with narrow flanges.

SYMBOLS

C_{BT}	torsion-bending constant, dependent upon location of axis of rotation and dimensions of cross section, inches ⁶
C_B	major part of C_{BT}
C_T	minor part of C_{BT}
D	flexural stiffness of plate $\left(\frac{Et^3}{12(1-\mu^2)} \right)$
E	modulus of elasticity, ksi
G	shear modulus of elasticity, ksi
I_p	polar moment of inertia of lip-flange cross section about axis of rotation, inches ⁴
J	torsion constant for lip-flange section, inches ⁴ (Product GJ in torsion problems is analogous to product EI in bending problems)
S^{IV}	stiffness in moment distribution analysis for far edge supported and subjected to sinusoidally distributed moment equal and opposite to moment applied at near edge
S^V	stiffness in moment distribution analysis for far edge not supported but elastically restrained against rotation and deflection
k_W	nondimensional coefficient used in plate-buckling formula
b_L	width of lip, inches
b_F	width of flange, inches
b_W	width of web, inches
t	thickness of plate, inches
σ_{cr}	critical compressive stress, ksi

- λ half wave length of buckles in longitudinal direction, inches
- η nondimensional coefficient for plates which accounts for decrease of modulus beyond elastic range; it also is influenced by slight discrepancies between actual specimen tested and idealized specimen for which calculated strength is made
- τ nondimensional coefficient for columns corresponding to η for plates

Subscripts:

- F flange
- L lip
- W web

THEORY

Observations of tests of lipped Z-columns show that one type of buckling occurs when the lip width is large and another type when the lip width is very small. Figure 2 shows the two types of buckling. When the lip width is large there is only rotation of all the joints. When the lip width is very small, however, there is a combination of rotation of all the joints and deflection of the lip-flange joints. Since in the method of moment distribution, the assumption is made that no deflection of the joints occurs, it is apparent that the method is not applicable when the lip width is small. A method of solution must consequently be used which takes into account deflection as well as rotation of the joints.

The present method for small lip widths considers the lipped Z-column as consisting of three structural units -- the web and a pair of lip-flange combinations. The lip-flange joint is thus allowed to deflect as well as to rotate. The buckling load is then obtained from the criterion that the sum of the stiffnesses of the two plates joined along a common edge must be zero:

$$S_{web}^{IV} + S_{flange}^V = 0 \quad (1)$$

This criterion is identical with the neutral-stability criterion of reference 1.

ASSUMPTIONS

For the calculation of the local buckling strength of the lipped Z-column with small lip width the following assumptions were made:

- (1) The actual cross section, which may have rounded corners, can be replaced by an idealized cross-section as shown in figure 1
- (2) The lip-flange combination rotates about an axis which is the intersection of the flange and web of the column
- (3) All the assumptions of the torsion-bending theory associated with the torsion-bending constant C_{BT} (references 2 and 3) are used
- (4) The types of deformation shown in Figures 2(a) and 2(b) occur independently of each other since they are of appreciably different wave lengths

An additional assumption is necessary when the buckling stresses are in the plastic range:

- (5) The plastic effects are approximately accounted for by using values of η and τ given in references 4 to 9

METHOD OF SOLUTION

For a solution of the problem of determining local buckling strength, the lipped Z-column is considered as three structural units: the web and a pair of lip-flange combinations. The stiffnesses of all three structural units at the intersections of the web and flanges are computed for several assumed values of wave length and buckling stress. With these stiffnesses known, the criterion of zero total stiffness at the two common intersections (equation (1)) can be applied. Thus, by a system of trial calculations and interpolations, the critical buckling stress of the plate assembly is obtained.

Stiffness of the Web

Since the two lip-flange combinations are similar, the web is a plate with the far edge supported and subjected to sinusoidally distributed moments equal and opposite to the moments applied at the near edge. The stiffness of the web S^{IV} can therefore be obtained from the stiffness tables of reference 10.

Stiffness of the Lip-Flange Combination

For the stiffness of the lip-flange combination, two types of stiffness must be considered: (1) the stiffness against cross-sectional deformation (Fig. 2(a)) and (2) the stiffness against lateral deflections of the lips (Fig. 2(b)). Inasmuch as the wave lengths of these two types of deformation are appreciably different, the deformations are assumed to occur independently of each other as already mentioned in the list of assumptions. It is therefore necessary to use only that type of stiffness for the lip-flange combination in the equation (1) which gives the lower critical stress.

The first type of stiffness - that is, stiffness against cross-sectional deformation - can be calculated by the method of moment distribution among the plate elements in which no deflection of the joints is assumed.

The second type of stiffness - that is, stiffness against lateral deflections of the lips - can be calculated from the formula

$$S_{\text{flange}}^V = - \frac{\pi^2 I_p}{4 \lambda^2} \left(\sigma_{cr} - \frac{\eta}{I_p} GJ - \frac{\tau}{I_p} \frac{\pi^2 E C_{BT}}{\lambda^2} \right) \quad (2)$$

which is taken from reference 11. The coefficients η and τ take into account the reduction of Young's modulus E when the material of the column is loaded beyond the elastic range. Values of η and τ can be obtained for assumed values of critical stress from the curves for various aircraft structural materials given in references 4 to 9. The coefficient C_{BT} consists of a major part C_B and a minor part C_T (reference 2 or 3). For the case of the lipped Z-column with a definite lip, the minor part,

$$C_T = \frac{1}{36} b_F^3 t_F^3 + \frac{1}{36} b_L^3 t_L^3$$

is small as compared with the major part C_B and can be neglected.

A lower limit for the major part C_B can be calculated by assuming the lip-flange combination free to slide along the web, for which case the formula, as derived by the methods of reference 3, is

$$C_B = \frac{1}{12} b_L^3 b_F^2 t_L \left(\frac{4 + \frac{b_L}{b_F} \frac{t_L}{t_F}}{1 + \frac{b_L}{b_F} \frac{t_L}{t_F}} \right) \quad (3)$$

An upper limit for C_B may be calculated by assuming the lip-flange combination fixed in the longitudinal direction at the intersection with the web. For this case, the method of reference 3 must be changed to make the longitudinal displacements of the flange zero. The following equation is then obtained:

$$C_B = \frac{1}{3} b_L^3 b_F^2 t_L \quad (4)$$

The two formulas (3) and (4) represent the limiting cases for C_B , that is, the flange-web joint free to slide and the flange-web joint fixed. The true condition will be an intermediate value. Since there is but little difference in the critical stresses calculated by the use of the two coefficients (formulas (3) and (4)) and since formula (3) gives the more conservative values, it is recommended for use.

Numerical Example

An example is given in the appendix to demonstrate the application of this method. The local buckling strength is calculated for lipped Z-column of $\frac{b_F}{b_W} \approx 0.7$, $\frac{b_L}{b_F} \approx 0.3$, and $\frac{b_W}{t} \approx 29$ for each type of deformation shown in figures 2(a) and 2(b).

COMPARISON BETWEEN THEORETICAL AND EXPERIMENTAL CRITICAL STRESSES

A comparison between theoretical and experimental critical stresses is shown in figure 3. The theoretical values calculated by the method of moment distribution are shown as the dotted line.

The theoretical values calculated by the method of the present paper by use of the limiting assumptions for C_B are shown as the two solid lines. These two curves bracket most of the experimental values obtained from plate-buckling tests of formed lipped Z-columns of 24S-T sheet material as shown by the circled test points. From this figure, it is concluded that theoretical critical stresses that agree well with experimental critical stresses can be calculated for all lip widths.

Langley Memorial Aeronautical Laboratory
National Advisory Committee for Aeronautics
Langley Field, Va. April 17, 1947

APPENDIX

NUMERICAL EXAMPLE

It is desired to calculate the local buckling strength of a lipped Z-column, formed from 24S-T sheet material, of the following dimensions:

$$b_L = 0.71 \text{ inch}$$

$$b_F = 2.52 \text{ inches}$$

$$b_W = 3.62 \text{ inches}$$

$$t = 0.126 \text{ inch}$$

With these dimensions known, the values of I_p , J , and C_B are calculated

$$I_p = \left(\frac{1}{3} b_F^3 + \frac{1}{3} b_L^3 + b_L b_F^2 \right) t = 1.2552 \text{ inches}^4$$

$$J = \frac{1}{3} (b_L + b_F) t^3 = 0.002154 \text{ inches}^4$$

$$C_B = \frac{1}{12} b_L^3 b_F^2 t \left(\frac{4 + \frac{b_L}{b_F}}{1 + \frac{b_L}{b_F}} \right) = 0.0807 \text{ inches}^6$$

The approximate equation for J is obtained from page 243 of reference 12.

The numerical computations are given in table I. The values in columns 1 and 2 are assumed. The values of column 3 which are trial elastic buckling stresses are calculated from the formula

$$\frac{\sigma_{cr}}{\eta} = k_W \frac{\pi^2 D}{b_W^2 t} \quad (A1)$$

With these trial elastic buckling stresses known, the values of column 4, which are trial buckling stresses, can be obtained from reference 4. With column 4 known, the values of η and τ , (columns 5 and 6) can be obtained from references 4 and 7, respectively. It will be noted that τ is taken for extruded material. It is considered that formed columns of the proportions of this specimen have material properties nearer to those of extruded material than to those of thin strip material since forming tends to increase the yield strength.

Column 7, which gives values for the stiffness of the lip-flange combination, is calculated by formula (2). The stiffness coefficients for the web, column 8, are obtained from reference 10. The values of column 9 are the stiffnesses of the web at either edge, and column 10 is the total stiffness of all the members intersecting at one edge of the web.

By graphical interpolation for each assumed value of $\frac{\lambda}{bW}$ (column 1), the value of k_W is obtained for which the total stiffness of the joint considered is zero. These values of k_W are shown in column 11. Also by graphical interpolation the minimum value of k_W is obtained. Figure 4 shows this interpolation for the minimum value of k_W . With this minimum value of $k_W = 3.99$ and equation (A1), the elastic buckling stress is calculated as

$$\frac{\sigma_{cr}}{\eta} = 46.7 \text{ ksi}$$

and from reference 4

$$\sigma_{cr} = 39.0 \text{ ksi}$$

The foregoing example was computed by use of the stiffness against lateral deflections of the lips. It is also necessary to consider the stiffness against cross-sectional deformation. This stiffness is considered when the method of moment distribution among the plate elements is used and no deflection of the joined edges is assumed. The computations are not included herein since the method is already in general use (reference 1). The relationship between σ_{cr} and $\frac{\sigma_{cr}}{\eta}$ of reference 4 is used to account for the plasticity effects. The critical stress calculated by the method of moment distribution is

$$\sigma_{cr} = 45.0 \text{ ksi}$$

Of the two types of buckling considered, the type occurring at the lower stress (39.0 ksi) is the type to be expected.

REFERENCES

1. Lundquist, Eugene E., Stowell, Elbridge Z., and Schuette, Evan H.: Principles of Moment Distribution Applied to Stability of Structures Composed of Bars or Plates. NACA ARR No. 3K06, 1943.
2. Lundquist, Eugene E., and Fligg, Claude M.: A Theory for Primary Failure of Straight Centrally Loaded Columns. NACA Rep. No. 582, 1937.
3. Hoff, N. J.: Stresses in Space-Curved Rings Reinforcing the Edges of Cut-Outs in Monocoque Fuselages. Jour. R.A.S., vol. XLVII, no. 386, Feb. 1943, pp. 35 - 83.
4. Lundquist, Eugene E., Schuette, Evan H., Heimerl, George J., and Roy, J. Albert: Column and Plate Compressive Strengths of Aircraft Structural Materials. 24S-T Aluminum-Alloy Sheet. NACA ARR No. L5F01, 1945.
5. Heimerl, George J., and Roy, J. Albert: Column and Plate Compressive Strengths of Aircraft Structural Materials. 17S-T Aluminum-Alloy Sheet. NACA ARR No. L5F08, 1945.
6. Heimerl, George J., and Roy, J. Albert: Column and Plate Compressive Strengths of Aircraft Structural Materials. Extruded 75S-T Aluminum Alloy. NACA ARR No. L5F08a, 1945.
7. Heimerl, George J., and Roy, J. Albert: Column and Plate Compressive Strengths of Aircraft Structural Materials. Extruded 24S-T Aluminum Alloy. NACA ARR No. L5F08b, 1945.
8. Heimerl, George J., and Fay, Douglas P.: Column and Plate Compressive Strengths of Aircraft Structural Materials. Extruded R303-T Aluminum Alloy. NACA ARR No. L5H04, 1945.
9. Heimerl, George J., and Niles, Donald E.: Column and Plate Compressive Strengths of Aircraft Structural Materials. Extruded 14S-T Aluminum Alloy. NACA ARR No. L6C19, 1946.
10. Kroll, W. D.: Tables of Stiffness and Carry-Over Factor for Flat Rectangular Plates under Compression. NACA ARR No. 3K27, 1943.
11. Lundquist, Eugene E., and Stowell, Elbridge Z.: Restraint Provided a Flat Rectangular Plate by a Sturdy Stiffener Along an Edge of the Plate. NACA Rep. No. 735, 1942.
12. Timoshenko, S.: Theory of Elasticity. First ed., McGraw-Hill Book Co., Inc., 1934.

TABLE I
ILLUSTRATION OF COMPUTATIONS FOR
NUMERICAL EXAMPLE

1	2	3	4	5	6	7	8	9	10	11
$\frac{\lambda}{b_W}$	k_W	$\frac{\sigma_{or}}{\eta}$	σ_{or} (reference 4)	η (reference 4)	τ (reference 7)	S^V (equation (2))	$\frac{S^{IV} b_W}{\eta D}$ (reference 10)	S^{IV}	$S^V + S^{IV}$	k_W
5.00	3.50	41.0	35.7	0.87	0.76	-0.132	0.476	0.224	0.092	
	4.00	46.9	39.0	.83	.62	-.194	.468	.210	.016	
	4.50	52.7	42.0	.80	.48	-.252	.459	.199	-.053	4.12
4.50	3.50	41.0	35.7	.87	.76	-.120	.466	.220	.100	
	4.00	46.9	39.0	.83	.62	-.203	.454	.205	.002	
	4.50	52.7	42.0	.80	.48	.283	.442	.191	-.092	4.01
4.00	3.50	41.0	35.7	.87	0.76	-.076	.456	.215	.139	
	4.00	46.9	39.0	.83	0.62	-.195	.440	.198	.003	
	4.50	52.7	42.0	.80	0.48	-.309	.424	.183	-.126	4.00
3.00	3.50	41.0	35.7	.87	0.76	.367	.436	.205	.572	
	4.00	46.9	39.0	.83	0.62	.060	.412	.185	.246	
	4.50	52.7	42.0	.80	0.48	-.232	.387	.168	-.064	4.38

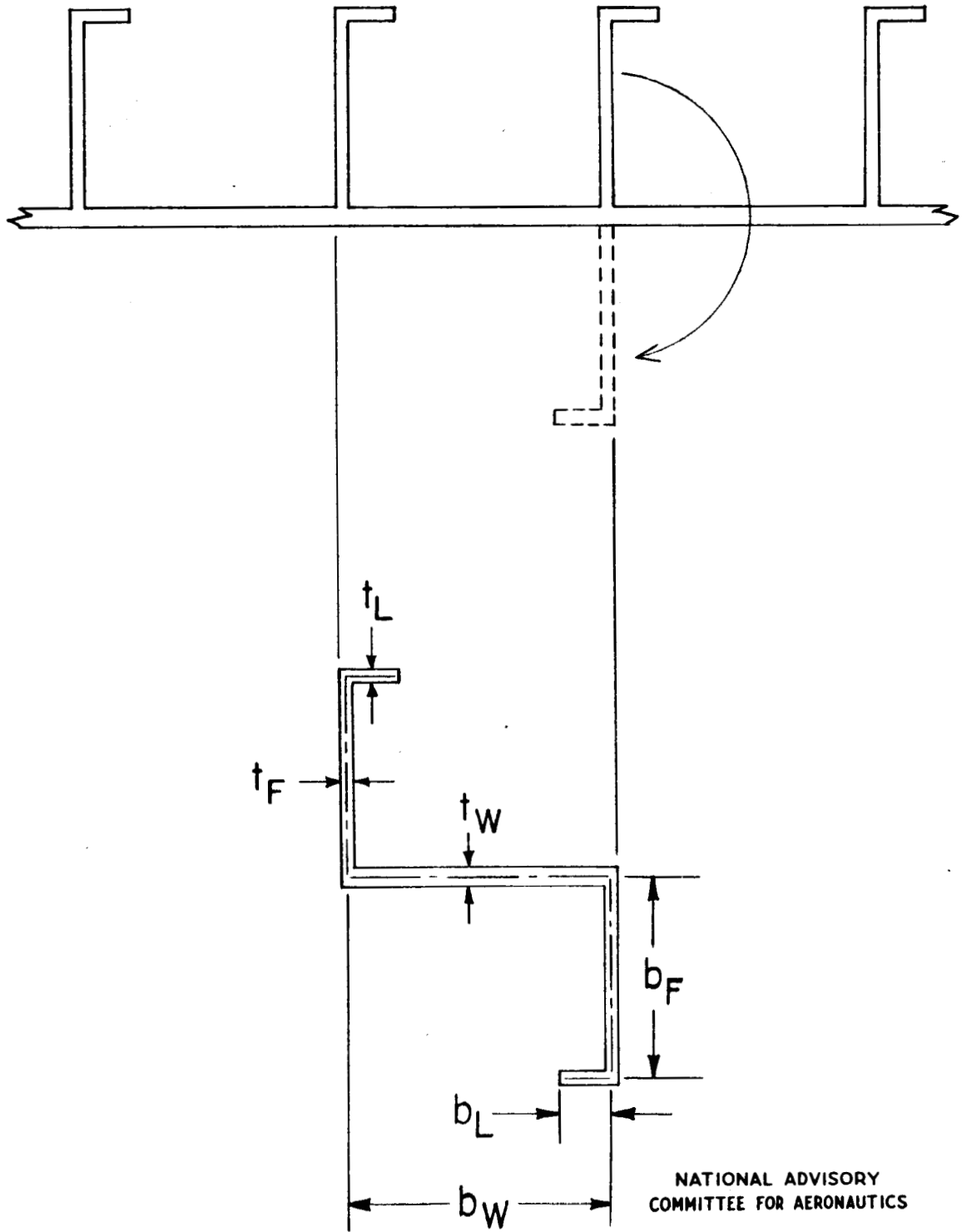
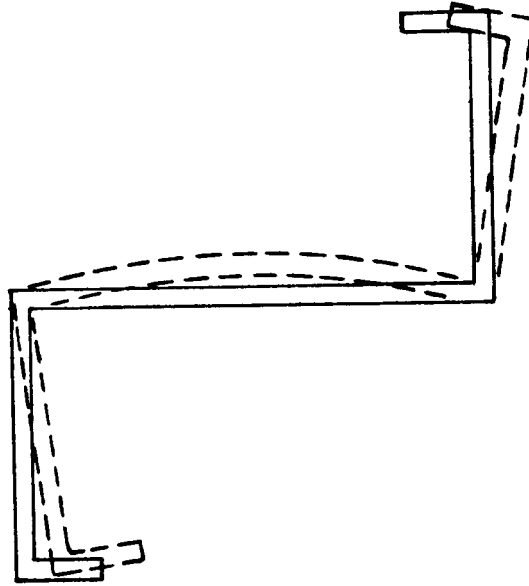
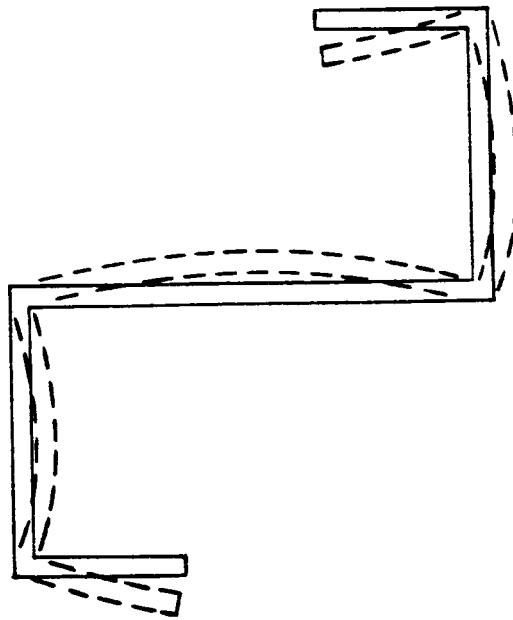

Figure 1.- Similarity of Z-stiffened panel and lipped Z-column.

NATIONAL ADVISORY
COMMITTEE FOR AERONAUTICS



(b) Small lip.



(a) Large lip.

Figure 2.- Buckling configurations.

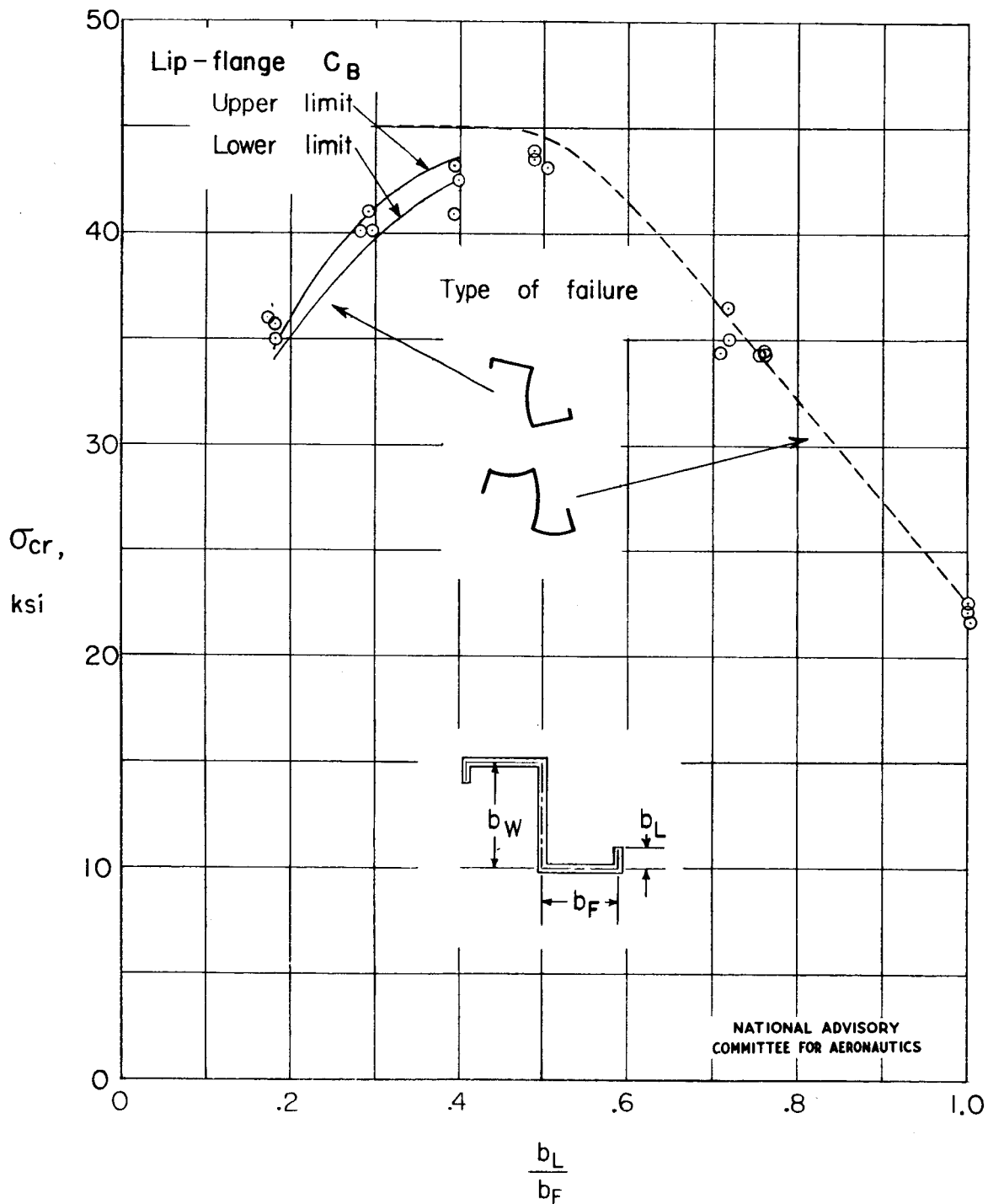

Figure 3.- Comparison of theoretical and experimental critical stresses for formed lipped Z-columns of 24S-T sheet material. $\frac{b_F}{b_W} \approx 0.7$; $\frac{b_W}{t} \approx 29$.

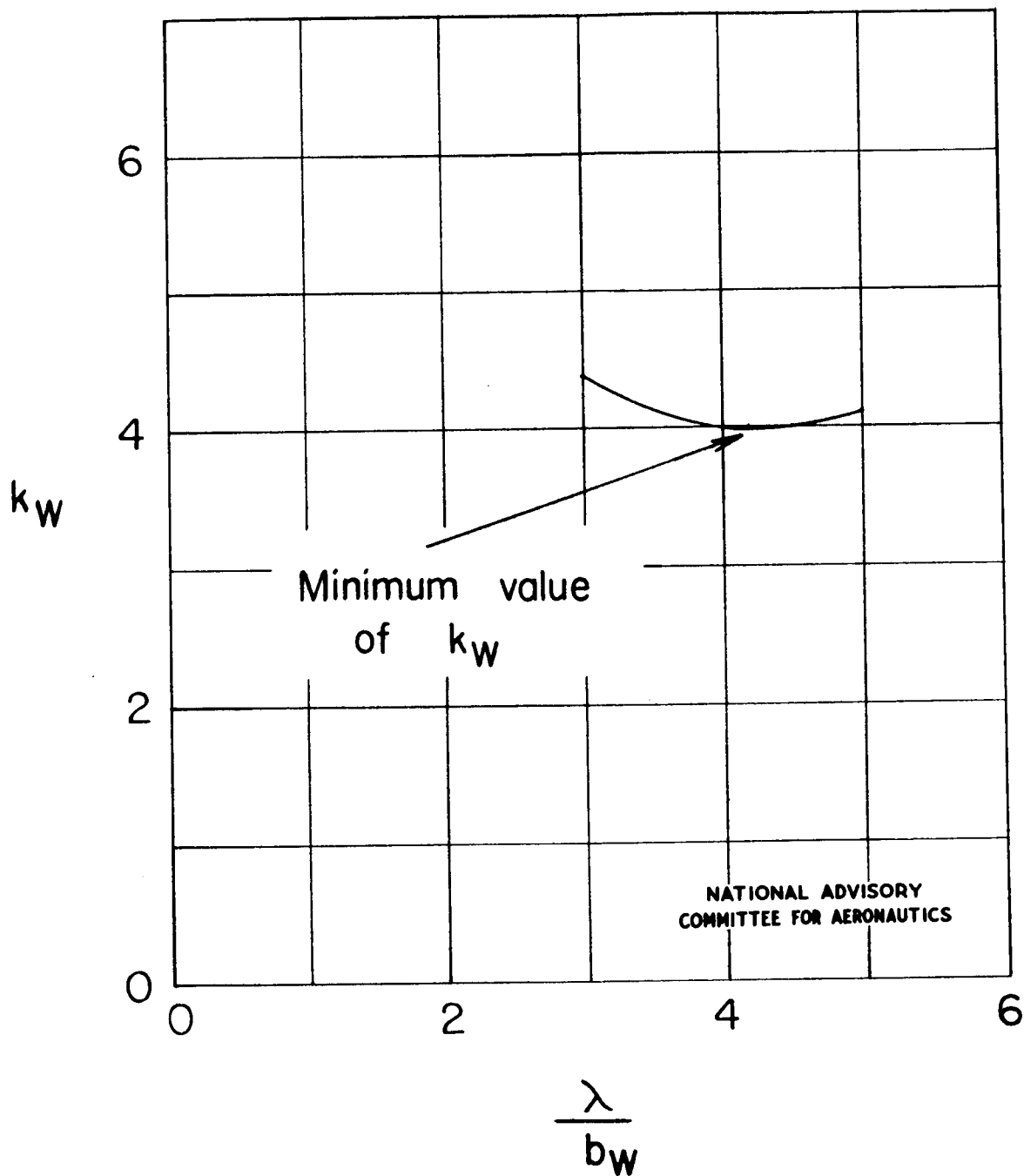

Figure 4.- Plot for finding minimum value of k_W for numerical example.