

NATIONAL ADVISORY COMMITTEE FOR AERONAUTICS

TECHNICAL NOTE

No. 1578

FRICITION OF SOLID FILMS ON STEEL AT HIGH SLIDING VELOCITIES

By Robert L. Johnson, Douglas Godfrey, and Edmond E. Bisson

Flight Propulsion Research Laboratory
Cleveland, Ohio



Washington
April 1948

NATIONAL ADVISORY COMMITTEE FOR AERONAUTICS

TECHNICAL NOTE No. 1578

FRICITION OF SOLID FILMS ON STEEL AT HIGH SLIDING VELOCITIES

By Robert L. Johnson, Douglas Godfrey, and Edmond E. Bisson

SUMMARY

An experimental investigation was conducted to identify the roles of solid-surface films in the various mechanisms of sliding and lubrication involved in the mating and compatibility of boundary-lubricated slider surfaces, in the action of extreme-pressure lubricants, and in the operation of slider surfaces not supplied with fluid lubricants.

The experiments were performed with an apparatus incorporating means for measuring sliding friction that consisted basically of an elastically restrained spherical rider sliding in a spiral path on a rotating disk. The disk specimens were treated to produce solid-surface films of various inorganic compounds. The experiments were conducted over a range of sliding velocities between 50 and 8000 feet per minute with loads from 169 to 1543 grams (108,000 to 225,000 lb/sq in., initial Hertz surface stress). Supplemental studies of friction specimens were made using standard physical, chemical, and metallurgical equipment and techniques including electron diffraction.

Molybdenum disulfide MoS_2 was very effective in reducing friction at high sliding velocities. This film material was very tenacious, was chemically and thermally stable, and consequently should have many practical applications.

It was determined that the formation of ferrous-ferric oxide $\alpha - \text{Fe}_3\text{O}_4$ on run-in sliding surfaces was beneficial with respect to friction and wear. Preoperational treatment of slider surfaces to form $\alpha - \text{Fe}_3\text{O}_4$ may be accomplished by a number of inexpensive and common proprietary commercial processes. Ferric oxide $\alpha - \text{Fe}_2\text{O}_3$, however, was not beneficial with respect to friction and wear over the entire range of sliding velocities.

Ferrous chloride FeCl_2 was more effective in reducing kinetic friction than ferrous sulfide FeS . This result would seem to indicate that chlorine compounds were more effective as

extreme-pressure lubricant additives than were sulfur compounds. Abrupt changes in friction, with increased sliding velocities, indicated critical material transformations of ferrous-chloride films. This condition favored the theory of the action of extreme-pressure lubricants, which state that the film material, formed by reaction of the lubricant additive with a surface, melts under extremely high temperatures or pressures and in that case the friction force will involve only shearing of a liquid film.

INTRODUCTION

Considerable evidence is available in literature (references 1 to 8) which indicates that solid surface films are important in the mating and compatibility of boundary-lubricated slider surfaces, in the action of "extreme-pressure" lubricants, and in the operation of slider surfaces that are not supplied with fluid lubricants. One of the least understood and most important factors in the operation of slider surfaces is the mechanism of the initial mutual accommodation (run-in). The effectiveness of, and the necessity for, careful initial operation of sliders have been adequately demonstrated in innumerable instances. Little explanation of the mechanisms involved has been offered, however, or improvement in them suggested. Certain physicochemical surface conditions have been associated with satisfactory and with unsatisfactory operation of metallic sliding surfaces (reference 1). Among those factors productive of satisfactory surface conditions is the formation and presence of specific solid surface films. An experimental determination of the effect of these films on kinetic friction would be of value in explaining the phenomena of mating of slider surfaces.

The most common and practical utilization of solid films on slider surfaces is embodied in extreme-pressure lubrication, wherein chemical films of low shear strength or of low melting point are formed by the action of lubricant additives on the slider surfaces under conditions of extreme temperature and pressure. Reference 2 presents a theory for the mechanism of extreme-pressure lubrication. Sliding-friction experiments with surface conditions closely controlled to simulate those theoretically present under operating conditions of extreme-pressure lubrication may aid in the clarification of the mechanics of such lubrication.

Operation of aircraft-turbine bearings at temperatures higher than those currently used may be of advantage, but available lubricants are deficient with respect to high-temperature operation. Because solid surface films that are chemically and thermally stable

may be selected, they may be effective in providing supplemental lubrication to compensate for the deficiencies of fluid lubricants at high temperatures.

Hughes and Whittingham (reference 3), Campbell (reference 4), Bowden and Tabor (reference 5), Roensch (reference 6), and many others have presented material relative to the use of surface films in reducing sliding friction. The importance of such films in boundary and in extreme-pressure lubrication is widely recognized and is discussed in references 7 and 8. The roles of these solid surface films in kinetic friction have not been isolated and studied under conditions of surface loading and at sliding velocities prevalent in current and proposed designs for sliding surfaces in aircraft power plants.

An investigation was conducted at the NACA Cleveland laboratory to obtain evidence on the effects of solid surface films on sliding friction at high sliding velocities and to clarify the roles of such films in the mating of sliding surfaces, in extreme-pressure lubrication, and in supplementary or dry lubrication.

The coefficient of kinetic friction and the wear characteristics of steel specimens so treated as to have solid chemical films that are predominantly of the materials desired were determined by experiments. This investigation was made with loads from 169 to 1543 grams (108,000 to 225,000 lb/sq in., initial Hertz surface stress) at sliding velocities up to approximately 8000 feet per minute. These films were of the same composition as those generally employed for use as supplemental lubricants in practical applications of sliders or films of high chemical and thermal stability and desirable structural properties. The investigation included physicochemical studies of specimens before and after slider operation as a means of determining the mechanism leading to the observed effects and of assuring positive control of surface conditions. Friction measurements were made by means of an apparatus that consists basically of an elastically restrained spherical rider sliding on a rotating disk. This research is a continuation of that reported in reference 9.

APPARATUS AND PROCEDURE

The experimental friction and wear studies were conducted with the equipment described in reference 9. Figure 1 is a diagrammatic sketch of the basic parts of the equipment. The principal elements of the apparatus are the specimens, which are in the form of an elastically restrained spherical rider and a rotating disk. The rider is loaded by weights applied along the vertical axis of the rider holder. Friction force between the rider and the disk is measured by four strain gages mounted on a copper-beryllium dynamometer ring. The force is indicated by either a recording- or an observation-type calibrated potentiometer converted to use as a

friction indicator. The coefficient of friction is computed by dividing the measured friction force by the applied normal load. An electrically driven radial-feed mechanism, calibrated to indicate radial position of the rider, causes the rider to traverse a spiral track on the rotating disk. The disk is mounted on an inertia ring that is supported and located by a bearing housing. The rotating specimen is driven by a direct-current motor through a flexible coupling and a speed-reduction unit that allows speed control over a range of sliding velocities between 50 and 14,000 feet per minute. The disk and rider are covered by a housing and shield, which permits the operating atmosphere of dried air to be slightly pressurized. The system for drying the air for the operating atmosphere consists, in sequence, of a 48-inch filter tube containing surgical cotton, a series of six silica-gel commercial drying elements, and an 8-inch tube containing aluminum anhydride. The air is obtained from the laboratory compressed-air system. In conducting the experiments, the disk is rotated at a predetermined speed and, by means of a cam arrangement, the loaded rider is lowered onto the disk as the radial feed is started. As the rider traverses the disk, friction force is observed or recorded with a potentiometer and disk rotative speed is determined with an electric revolution counter and a synchronized timer. The run is terminated by lifting the rider from the disk surface. Mean sliding velocity for the experiment was computed from the recorded rotative disk speed and the mean diameter of the rider path. A change in diameter of the rider path on the disk resulting from the radial travel of the rider caused a maximum deviation in sliding velocity of approximately 1 percent from the mean value. An unworn surface of a ball was used in each experiment. Separate runs were made to determine friction, wear, and effect of continuous sliding.

As reported in reference 9, uncontrolled variables, such as wear of the rider, natural frequency of the restraining assembly, and vibrations induced by the driving mechanism, had no appreciable effect on accuracy of the data. The results obtained are believed to represent reproducible, relative data.

The physical and physicochemical conditions of the surface and subsurface material of the research specimens were studied before the sliding-friction experiments by means of surface-roughness and surface-hardness measurements and electron-diffraction and metallographic studies. The surfaces were studied after the experiments by using electron-diffraction and metallographic techniques. During the experiments, no measurable change in surface hardness occurred. Because of the nature of the surface disturbance by sliding, roughness measurements were insignificant.

The limits of experimental error in the friction values presented were not constant in all the experiments because of uncontrollable inconsistencies in the film characteristics. In all but isolated cases, the margin of error in the coefficient of friction was within ± 0.02 of the values given and in general was considerably less. The data presented are complete data from a representative experiment for each type of film, selected on the basis of a mass of data (at least four experiments) on each variable. For comparison purposes, a load of 269 grams is used for all the summary curves reported because this load produces an initial surface stress (126,000 lb/sq in., Hertz) that is in the range of maximum limiting values used in design of components such as reduction gearing.

SPECIMEN PREPARATION

Careful preparation of specimens has been found to be the most important single requisite for success of the experiments. The disk specimens had a 13-inch outside diameter, were of normalized SAE 1020 steel with a Brinell hardness number of 185, and were finished and cleaned according to the detailed procedure given in reference 9. The disk surfaces were so finished as to minimize surface working and to give a uniform nondirectional surface finish with a roughness of 3 to 6 microinches rms as measured with a profilometer. The rider specimens used were commercially made balls, $\frac{1}{4}$ inch in diameter, of SAE 1095 steel hardened to Rockwell number C-60; they were not subjected to laboratory finishing operations before use but were cleaned and rinsed in 190-proof ethyl alcohol before the runs.

In this investigation, solid surface films of ferric oxide Fe_2O_3 , ferrous-ferric oxide Fe_3O_4 , ferrous chloride $FeCl_2$, ferrous sulfide FeS , molybdenum disulfide MoS_2 , and graphitic carbon C were deposited on the disk specimens according to the procedures described in the appendix. (Wherever Fe_3O_4 is mentioned herein, the possibility that it could also be $\gamma - Fe_2O_3$ should be considered, because the two are indistinguishable by usual diffraction methods. Otherwise all compounds are of the alpha form.) The surface films were predominantly of the compositions indicated, as determined by analyses of the electron-diffraction patterns shown in figure 2.

RESULTS AND DISCUSSION

Films Formed during Run-In

The mechanism of the initial mutual accommodation of mating slider surfaces is only slightly understood but is of considerable importance. It is generally accepted that with extended periods of low-power operation during the initial operation of an engine the slider surfaces give better performance and much more satisfactory service life than if such precautions were not taken. Electron-diffraction and X-ray diffraction studies (reference 1) have associated the occurrence of specific surface conditions with desirable or with undesirable running properties of sliders operating with reciprocating motion under changing or steady loads. One of the principal variables observed on run-in surfaces was the presence of isolated and mixed oxides of iron. By comparing the predominant oxide present with the appearance of the run surface, it was thought that the presence of ferrous oxide FeO and ferrosio-ferric oxide Fe_3O_4 was beneficial to slider surfaces and that the presence of ferric oxide Fe_2O_3 was not beneficial. On scuffed surfaces, Fe_2O_3 was observed and on well run-in surfaces Fe_3O_4 was observed.

Results indicating that FeO is effective in reducing friction between sliding surfaces are presented in reference 9. Difficulties in producing a solid film of ferrous oxide on the large disk specimens prevented a complete evaluation of its effectiveness in reducing friction in the investigation reported.

The experimental results obtained in determining the effect of velocity on friction for Fe_3O_4 and Fe_2O_3 are shown in figure 3. The general trend of friction is to decrease with velocity for all loads. The coefficient of friction is dependent on load in the presence of this applied film of Fe_3O_4 and similar trends of friction with increased sliding velocities can be established for each of the loads investigated (fig. 3(b)). When a solid film of Fe_2O_3 is present on the disk surface, the coefficient of friction is essentially independent of load, as shown in figure 3(c). The general friction trend shows a decrease with an increase in velocity. Undetermined physical or chemical characteristics of the film material may be the cause of the friction-load relations. Reference 9 shows the coefficient of friction of dry clean steel to be independent of load.

As compared to the dry-steel friction curve from reference 9, Fe_3O_4 is very effective in reducing friction (fig. 3(d)). On the other hand, Fe_2O_3 is not beneficial when compared to the dry steel friction curve at the low ranges and the high ranges of velocity but does show lower friction values in the velocity range from approximately 1000 to 3600 feet per minute. The differences in the coefficient of friction are, however, nearly within the limits of experimental error (± 0.02) at this level of friction values. In all cases, as figure 3(d) shows, the friction of a surface coated with Fe_3O_4 is appreciably less than that of a surface coated with Fe_2O_3 .

Comparison of the wear data and of the wear-area photomicrographs presented in figure 4 with the data of reference 9, which reported the wear spot formed during operation of dry steel on steel to be 0.038 inch in diameter, shows that the presence of oxides has no great effect on wear. The presence of Fe_3O_4 on disk specimens caused approximately a 10-percent reduction in the diameter of the rider wear areas, and the presence of Fe_2O_3 caused a 5-percent increase. It should be noted that the relative effects of the two oxides on wear show the same trend as that observed in the case of the friction measurements (that is, the Fe_3O_4 film was beneficial and the Fe_2O_3 film was not beneficial). Comparison of the photomicrographs of the wear areas (fig. 4) indicates that the degree of surface disturbance may be qualitatively associated with the crystal size of the film material. The material with the smaller crystals (Fe_3O_4) caused less wear and less severe surface disturbance (that is, fig. 4(a) indicates much less welding and tearing of the rider than does fig. 4(c)). The oxide coating formed on surfaces during lubricated sliding reduces wear of sliders (reference 10); on the basis of the work reported in reference 1 and herein, it is believed that the oxide reported in reference 10 was ferroso-ferric oxide.

The trend of decreased friction with increased sliding velocities observed in most of the data reported herein is considered due to the physical changes in the surfaces that were discussed in reference 9. The presence of films on the surface would probably not eliminate physical changes caused by changes in sliding velocity. The results shown in figures 3 and 4 generally verify the qualitative estimates of reference 1 on the influence of Fe_3O_4 and Fe_2O_3 on friction and wear.

An explanation of the low friction values obtained with the Fe_3O_4 film may lie in its tenacity to the base metal. An examination of the electron-diffraction patterns from the two oxide films showed that, as produced in this work, the Fe_3O_4 film was composed of smaller crystallites than was the Fe_2O_3 film. The patterns also showed that the Fe_2O_3 film was more likely to be composed of oriented crystals. Thus the Fe_3O_4 film is composed of finer and more uniform crystals than the Fe_2O_3 film. This property of the Fe_3O_4 film suggests higher load-carrying capacity, which may be traced to the film tenacity. Small crystals growing on a steel surface adapt themselves to the irregularities of the steel more readily than larger ones and therefore make the film as a whole more tenacious. The Fe_3O_4 film discourages plowing and ripping and thus helps to prevent metal-to-metal contact and to keep the friction values low.

It should be observed also that Fe_3O_4 can oxidize to Fe_2O_3 when the passing rider raises the local temperature and pressure to extremes. This possibility of a chemical change is further support that Fe_3O_4 is a better film for sliding than is Fe_2O_3 , inasmuch as the oxidation of Fe_3O_4 would produce no drastic film deformation, but when Fe_2O_3 is subjected to extremes (of temperature particularly) it thickens and ruptures as scale.

It is known (reference 11) that an oxide film of iron occurring naturally is composed of three "layers": FeO next to base metal, Fe_3O_4 in the middle, and Fe_2O_3 on the surface. The layers are indistinct, and because of the blending, it seems that the simple cubic structure of FeO is more compatible with the spinel cubic structure of Fe_3O_4 than with hexagonal structure of Fe_2O_3 . These facts indicate that, in this work, the prepared Fe_3O_4 film adheres to and is supported by an FeO layer; whereas the prepared Fe_2O_3 film probably adheres to a thin Fe_3O_4 layer, which in turn adheres to and is supported by FeO . In the case of the Fe_2O_3 film, this oxide exists close to FeO , separated only by a thin Fe_3O_4 layer. When critical sliding conditions are produced on the Fe_2O_3 film, it therefore cannot support the rider because it is not structurally compatible with its base of FeO , and the rider plows or rips through to the bare metal with a resultant increase in friction.

The presence of an extremely thin film of Fe_3O_4 on cleaned specimens is discussed in reference 9. It is assumed that such a film was present on the rider before all the experiments reported herein. When the factor of compatibility is considered, it is probable that two Fe_3O_4 films rubbing together would have less resistance to sliding than would result from a film of Fe_3O_4 sliding on a film of Fe_2O_3 . The friction results presented in figure 3(d) support this view because the combinations of surface films discussed were present.

It is also possible that the effect of Fe_2O_3 on friction may be due solely to its physical characteristics, although little is known of its behavior under pressure. It is a hard, coarse-grained material that, when introduced between sliding surfaces, may be embedded in one of the surfaces and function as a microscopic surface asperity thereby increasing the surface roughness. It will be recalled that a roughness factor is included in practically all expressions of fundamental friction relations and that increased surface roughness causes increased friction (reference 12).

It would be difficult to employ solid coatings of FeO on steel in practical applications, because the formation of the compound involves temperatures above the annealing points of many steels, and because of the difficulty in processing large parts. Bowden and Ridler (reference 13) showed that hot spots occur at surface asperities of contacting sliders, which with increased loads ultimately reach the melting point of one of the materials. The localized temperatures reached are such that, with the proper surrounding atmosphere and quenching conditions, quantities of stable FeO may be formed on the contacting surfaces; this condition is described in reference 9.

Each of the oxides should be evaluated with respect to its practical use on slider surfaces. Because Fe_2O_3 is very easily formed on steel surfaces and because this material is deleterious with regard to friction and wear, conditions that might cause formation of Fe_2O_3 should be avoided in the finishing, handling, and operation of sliders. Because of the high temperatures required for the formation of FeO , its use as a friction- and wear-inhibiting coating on sliders is impractical. For these reasons, Fe_3O_4 is the only iron oxide studied that is beneficial and has practical application.

A number of commercial surface treatments employing caustic baths and several others types of chemical solution in the

formation of corrosion-resistant and wear-resistant surface films have been studied. When films formed by several commercial treatments bearing various proprietary designations were subjected to electron-diffraction studies, it was revealed that their principal constituent was Fe_3O_4 , as shown in figures 2(c) and 2(d). In the approximate speed range between 1200 and 5000 feet per minute, two of the commercial treatments (references 14 and 15) cause reduced friction, and the trend is roughly comparable to that obtained with the film of isolated Fe_3O_4 (fig. 5). Comparative wear data for these treatments are presented in figure 6. Wear differences observed between the experimentally and commercially deposited Fe_3O_4 may be explained on the basis of additional compounds in the films formed by the commercial treatments.

In comparison with dry steel, the laboratory-prepared Fe_3O_4 films cause friction to be decreased at all sliding speeds investigated and also cause a reduction in rider wear. Commercially prepared films containing Fe_3O_4 were also beneficial with regard to friction and wear except at high-sliding velocities. During the operation of steel slider surfaces that have attained satisfactory mutual accommodation, Fe_3O_4 is formed (reference 1). These facts show that Fe_3O_4 is beneficial on slider surfaces and indicate that pretreatment of sliders may eliminate many surface failures during the initial operation of sliders. A number of inexpensive proprietary surface treatments are commercially available, which will form films that are predominantly Fe_3O_4 .

Films Formed by Extreme-Pressure Lubricants

Primary operational requirements for lubricants used in aircraft power plants have necessitated the use of lubricant additives to obtain the necessary increased load capacity for low-pour-point lubricants. Most of the extreme-pressure additives used to increase load capacities of lubricants contain active chlorine or sulfur compounds. Reference 2 presents a chemical basis for consideration of the mechanisms of action of these additives.

Quantitative information that enables evaluations of films of the type formed by compounded lubricants (reference 2) is presented in figures 7(a) and 7(b) in a manner that partly clarifies the mechanism of action of the additives. Figure 7(a) shows the effect of load on the coefficient of friction for a disk specimen coated with ferrous chloride FeCl_2 . The lack of continuity of these

curves and the noncompliance with Amonton's law indicate primary physical changes in the film material. Ferrous sulfide FeS forms a more stable film than ferrous chloride. No trend in load effects on the coefficient of friction was observed with a film of ferrous sulfide on the disk specimen (fig. 7(b)). It is shown in figure 7(c) that, in general, isolated solid surface films of low-shear-strength compounds of types formed by chemically reactive extreme-pressure lubricant additives reduce sliding friction over the range of sliding velocities investigated. These data demonstrate that ferrous chloride is much more effective as a solid-film lubricant than is ferrous sulfide. The ferrous-sulfide film caused friction to be greater at sliding velocities above 4600 feet per minute than that observed for dry, untreated steel (data from reference 9).

No dependable wear data were obtained with the ferrous-chloride films. The wear areas on the riders were poorly defined and their sizes were inconsistent. Because the deliquescent nature of ferrous chloride promotes the formation of hydrochloric acid, the rider was corroded after removal from the friction apparatus; this etching of the surface obliterated the geometric definition of the wear areas. Figure 8 shows the surface appearance of the wear spot on the rider used in the ferrous-sulfide run. The surface of this specimen appears similar to that observed after experiments with Fe_3O_4 films; there is no indication of severe surface welding although the ferrous sulfide does not seem to be beneficial in respect to wear.

Two theories of the action of ferrous chloride as an extreme-pressure lubricant film are presented in reference 2, page 116; these theories are: "(1) under existing conditions at the contact points, solid ferrous chloride may readily shear; (2) temperatures at the contact points may become high enough to melt the ferrous chloride Overcoming friction force will then involve shearing only a liquid film of ferrous chloride ..."

It is possible to interpret the data of figure 7(a) as verification for the theories of extreme-pressure lubrication. The curve for ferrous chloride (fig. 7(a)) shows that at the low sliding velocities (up to 2000 ft/min) there is a critical variation in friction with slightly increased sliding velocities, and that at high sliding velocities (5000 to 6000 ft/min with a load of 269 grams), there is a sharp decrease in friction indicated by a discontinuity in the data. These abrupt changes in friction values indicate that critical transformations in sliding conditions take place. The most logical transformations would be those of phase

changes and melting of the ferrous-chloride film. The variation in friction in the sliding-velocity range from 1600 to 2000 feet per minute at a load of 269 grams is attributed to some phase change in the ferrous chloride that affects its shear strength and is caused by higher temperatures resulting from increased sliding velocity. The sharp reduction in friction in the sliding-velocity range from 5000 to 6000 feet per minute with the 269-gram load and the similar reduction at lower velocities with heavier loads may indicate the presence of a fluid film resulting from melting of the solid material.

These results indicate that both theories for the action of films formed by extreme-pressure additives may be substantiated under certain conditions of sliding. Under the conditions of shock or of extreme loading that necessitate the use of extreme-pressure lubricants, a liquid form of the film material is probably obtained.

Supplemental or Dry-Lubrication Films

At the extremely high ambient temperatures and high loads encountered in an increasing number of practical lubrication problems, currently used hydrocarbon lubricants are not completely effective. Use of supplementary or dry lubrication by solid-film materials is one method of improving lubrication under these conditions. Several chemically and thermally stable materials are available that might be effective in reducing friction and wear under extreme conditions. Two of the best examples of such film materials are molybdenum disulfide MoS_2 and graphitic carbon C. These materials are similar in that both have laminar structures. Molybdenum disulfide has been used as a die lubricant in the forging of metal parts (reference 16) and as a bearing lubricant for a rotating anode X-ray tube (reference 17). Graphite is a more commonly used lubricant and has been employed in numerous applications.

Data showing the effectiveness of molybdenum disulfide and graphite (graphitic carbon) as solid-film lubricants at high sliding velocities are presented in figure 9. Use of molybdenum disulfide produces a trend toward progressively lower values of friction as sliding velocity is increased and under the conditions reported, reduces friction more than the use of graphite. Figures 9(a) and 9(b) show that, with solid films of either molybdenum disulfide or graphite on disk specimens, Amonton's law does not hold over the entire range of loads investigated. The coefficient of friction increases slightly with load in the presence of a solid

film of molybdenum disulfide (fig. 9(a)). For the lowest loads, friction increased slightly with load in the presence of a solid film of graphite (fig. 9(b)). The tendency for friction to increase with higher sliding velocities at velocities above approximately 2000 feet per minute indicates the partial failure of the graphite film. At the highest load that a complete curve can be plotted (1017 grams), with velocities above 3000 feet per minute, the friction trend (downward) corresponds to that of the base metal (reference 9), which indicates an almost complete failure of the lubricating film. For purposes of comparison, friction data for dry- and boundary-lubricated surfaces taken from reference 9 are also presented in figure 9(c). At high sliding velocities, molybdenum disulfide is nearly as effective in reducing friction as one of the best polar-type boundary lubricants, oleic acid.

The condition of the surfaces after sliding is shown in figure 10. The wear-area photomicrograph shown in figure 10(d) indicates that, at the conditions of the wear experiments, the graphite film was failing. This condition is illustrated by the degree and type of surface disturbance in the wear area. It is believed that a welding and tearing-out action, such as may be observed between unlubricated steel surfaces (reference 9, fig. 9), occurred between the surfaces of the rider and the disk. Figure 11 shows the condition of the steel disk covered with molybdenum disulfide after the friction and wear experiments. The entire disk, which shows the areas where test runs were made to determine both wear and friction is presented in figure 11(a). The wear run was made at the innermost circumferential trace and the friction runs were made between this wear trace and the outermost circumferential trace. Figure 11(b) and 11(c) are close-ups of the disk at successively higher magnifications to show the surface conditions more clearly. In figure 11(b), the continuous run indicates that the rider, at its high initial surface stress, has not penetrated the film to the steel throughout the entire length of the track. The combination of low value of friction and minor surface damage to the rider during this run indicates that this penetration has had no serious effect. The same continuous trace and the friction traces are shown at higher magnification in figure 11(c). It will be observed that in none of the friction traces did the film fail so as to allow the rider to penetrate to the steel base metal, which is important in view of the initially high Hertz surface stresses (108,000 to 225,000 lb/sq in.) to which the film was subjected.

Because the graphite film failed to the extent of allowing welding of the surfaces to take place and the molybdenum-disulfide film did not fail to this extent, the wear measurements of figure 10

cannot be used as an indication of the relative lubricating qualities of the two film materials in reducing wear at the loads used in these experiments. Experiments at less severe conditions would be necessary for such an evaluation and that work is not warranted because it is established herein that molybdenum disulfide is more satisfactory than graphite as a solid-film lubricant at high sliding velocities. It has also been shown in reference 18 that molybdenum disulfide is more satisfactory than graphite as a solid-film lubricant at high pressures and low velocities.

The failure of graphite as a solid-film lubricant at high sliding velocities can be plausibly explained by considering the mechanism of its lubricating action as presented by Van Brunt and Savage in reference 19 who reported that the lubricating action of graphite arises from the action of moisture adsorbed on the graphite particles. If an adsorbed film of water is not present, the graphitic carbon acts as abrasive particles. The heat developed during sliding at the high velocities is probably sufficient to cause partial desorption of the adsorbed water film on the graphite, thus destroying its lubricating qualities.

Molybdenum disulfide is stable at high temperatures (melting point, 1185°C) and pressures (reference 18). Each lamina of this compound is composed of a sheet of molybdenum atoms with a sheet of sulfur atoms on each side. One of these laminae adheres strongly to the iron surface because of a strong metal-sulfur bond. The other laminae slip easily because of the weakness of the sulfur-sulfur bond.

The tenacity of molybdenum disulfide as a film material was demonstrated by the continuous run of the rider without radial traverse on the film using a 269-gram load with a sliding velocity of 4000 feet per minute over a period of 30 minutes. Stable but slightly increasing friction values were observed. The slight film failure that occurred was not serious enough to allow welding to take place between the sliding surfaces. In another experiment, a rider with a contacting area such as to give an apparent loading of 3000 pounds per square inch was allowed to slide on a continuous track at a velocity of 4000 feet per minute for a period of over 2 hours; there was little change in friction and no sign of failure of either the steel or molybdenum-disulfide surfaces. The rider did not penetrate the molybdenum-disulfide film to the steel base at any location during this experiment. The possible use of molybdenum disulfide as an addition agent in fluid lubricants should be questioned in accordance with the line of reasoning that has prevented the complete acceptance of various forms of graphite

for such an application. Molybdenum disulfide is insoluble in common fluid lubricants; consequently, it is probable that the compound would deposit in undesirable accumulations throughout a lubrication system.

SUMMARY OF RESULTS

An experimental investigation was conducted with a kinetic-friction apparatus consisting basically of an elastically restrained spherical rider sliding on disks lubricated with several types of dry solid film. The experiments were conducted over a range of velocities from 50 to approximately 8000 feet per minute with loads from 169 to 1543 grams (108,000 to 225,000 lb/sq in., initial Hertz surface stress) and with supplemental studies using standard physical, chemical, and metallurgical equipment and techniques. The following results were observed:

1. A solid film of molybdenum disulfide MoS_2 was very effective in reducing friction at high sliding velocities. The film material was easily applied, was very tenacious, was chemically and thermally stable, and consequently could have many practical applications. The molybdenum disulfide has a laminar structure similar to graphite and because of its tenaciousness was more satisfactory than graphite as a solid-film lubricant at high sliding velocities.

2. The formation of ferroso-ferric oxide Fe_3O_4 on sliding surfaces is desirable with respect to friction and wear. Pretreatment of slider surfaces to form Fe_3O_4 may be accomplished by a number of inexpensive and common commercial treatments. Ferric oxide $\alpha - \text{Fe}_2\text{O}_3$, on the other hand, was not generally beneficial, with respect to friction and wear, over the entire range of sliding velocities.

3. Solid films of ferrous chloride FeCl_2 were more effective in reducing friction than were ferrous-sulfide FeS films. This result substantiated the work of other investigators which indicates that chlorine compounds are more effective as extreme-pressure lubricant additives than sulfur compounds.

4. Abrupt change in the friction trend of ferrous-chloride films with increased sliding velocities indicated critical material transformations. This condition favors the theory for the mechanism

of action of extreme-pressure lubricants containing chlorine compounds, which indicates that temperatures at the contact points may become high enough to melt the ferrous chloride so that overcoming friction force will involve the shearing of only a liquid film.

Flight Propulsion Research Laboratory,
National Advisory Committee for Aeronautics,
Cleveland, Ohio, December 4, 1947.

APPENDIX A - FILM PREPARATION

The production of inorganic films having common physical characteristics was an important factor influencing the manner of preparation. Uniformity in thickness, grain size, smoothness, cleanliness, physical strength, and tenaciousness of the various films was sought. The treatment of the individual steel disks was developed until the film that was formed was uniform over the entire surface.

The finishing and cleaning procedure summarized here is described in detail in reference 9. Each disk was subjected to a similar milling, grinding, and lapping procedure, which was followed by a cleaning procedure essentially as follows:

1. Degrease in low-aromatic cleaning naphtha
2. Abrade with 3/0 emery paper
3. Wash with mixture of 50-percent benzene and 50-percent acetone
4. Scrub with levigated alumina
5. Rinse in water
6. Rinse in 190-proof ethyl alcohol
7. Dry in clean, warm air

The steel could then maintain a continuous water film, which on recession produced interference colors, indicating freedom from contaminating oils or greases. Insofar as possible, the disk was kept in an atmosphere of clean, dry air during transportation. After the treatment, the coated disk was immediately placed upon the friction apparatus, covered, and allowed to remain in a clean, dry atmosphere for 30 minutes. After this drying process, the friction characteristics were determined.

The chemical composition and crystalline characteristics of each film were determined by electron-diffraction patterns reproduced as figure 2. These patterns were produced with the diffraction adapter of the type EMB-4, RCA electron microscope. During treatment of the disk, a small specimen of the same steel was placed on the inner edge of each disk and subjected to the same treatment as the disk. After the film was formed, the diffraction

specimen was placed in the holder, inserted into the camera, and the pattern was photographed. It was assumed that the chemical composition of the film on the small specimen, as determined from the diffraction pattern, represented the chemical composition of the film on the disk.

Formation of Fe_3O_4 Film

Laboratory treatment. - A film of this compound was formed by heating steel in a restricted oxygen supply. A small range of temperatures and air pressures was allowed, and in this case the steel was heated to $375^{\circ}C$ on a 2000-watt heater, which was mounted inside a 15-inch metal bell jar in which the air pressure was 1 millimeter of mercury. The vacuum furnace was equipped with thermocouple leads for temperature indication. After 30 minutes, the film has reached a thickness that produced a blue interference color indicating that the thickness was in the order of 1200 Å. The steel was cooled to room temperature by cooling the vacuum furnace while maintaining the same or lower air pressure. The disk was transported in a clean, dry atmosphere.

Commercial treatment. - Similar black, tenacious films were formed on clean steel disks by a caustic-sulfur treatment (reference 14) and by a caustic-potassium nitrate treatment (reference 15). In the caustic-sulfur treatment, the clean disk was immersed in a bath consisting of 50-percent sodium hydroxide NaOH, 49-percent water H_2O , and 1 percent sulfur S (powdered) for 20 minutes. The bath was maintained between temperatures of 121° and $124^{\circ}C$ and constant agitation was employed. The coated disk was then washed in boiling tap water and rinsed in boiling distilled water. It was then dried in dry, clean air. The caustic-potassium nitrate treatment is very similar, the composition of the bath being 1 part potassium nitrate KNO_3 and 2 parts NaOH. The immersion is divided into two steps: the first is immersion in a bath, the temperature of which is maintained at $141^{\circ}C$ by dilution with water, the second step is to immerse the part into the second bath, which is held at $154^{\circ}C$. The length of time for each bath is not critical and depends upon the thickness of the film desired. In these experiments, the time was approximately 20 minutes for each bath. The disk was washed in boiling water and dried in clean air. Analysis of electron-diffraction patterns from films formed by both methods revealed the presence of Fe_3O_4 .

Formation of α - Fe_2O_3 Film

This oxide film, which contains the greatest amount of oxygen of the films investigated, was prepared by heating a steel disk to 350°C in clean, dry air at atmospheric pressure. The plate was removed from the heat when the interference colors present indicated that the film thickness was about 1200 Å. Further heating promoted spottiness and nonuniformity.

Formation of FeCl_2 Film

A chloride film was formed by exposing a warmed, clean steel disk to the hot vapor composed of an azeotropic solution of hydrochloric acid and water. In order to form this film, the warm disk was placed in a hot gas chamber (100°C), which was then partly evacuated. An inlet to the chamber led to a container in which the azeotropic solution of hydrochloric acid and water was boiling. When the valve was opened, a vapor composed of 20 percent water and 80 percent hydrochloric acid (the composition of the liquid) could envelop the disk. A 2-minute exposure was sufficient to form a thin, white, uniform coating. It was found necessary to insert a baffle and a condensate trap in the chamber to prevent the condensate from collecting and dripping onto the plate.

Formation of FeS Film

A ferrous-sulfide film was formed by exposing a heated disk to hydrogen sulfide H_2S gas. First, the clean steel disk was placed in the vacuum furnace at room temperature and the air pressure was reduced to 0.25 millimeter of mercury. Hydrogen sulfide was then admitted and the pressure again reduced. This process was repeated until the chamber was virtually purged of air. The disk was then heated to 350°C and an additional amount of H_2S was admitted. Under those conditions the film formed rapidly and the furnace was allowed to cool while the low pressure was maintained.

Formation of MoS_2 Film

Finely divided molybdenum disulfide was mixed into a smooth paste with an organic binder (commercial corn syrup). This homogeneous material was painted on a steel disk, the temperature of

which was 350° C. A thick, heavy coating was formed on the metal. After the disk cooled the outer, loosely adhering MoS₂ was scraped off with a straight edge. This action exposed a thin, tenacious undercoating, which upon further smoothing became gray-black and very smooth. The texture of the material was similar to that of flaky graphite. The disk was finished by light abrasion with 3/0 emery paper, followed by a washing in 190-proof ethyl alcohol. The coated disk was dried in the usual manner.

In order to check the effect of the corn syrup alone, some of it was painted on a hot steel disk. The result was a bubbly, crumbly, charred, nonadherent mass that had very little effect on friction compared to MoS₂.

Formation of Graphite Film

Graphite was deposited upon the surface of the steel disk by compressing flaky graphite into a cake, which was pressed against the rotating disk. Microscopic examination revealed graphite filling most of the recesses in the surface profile and electron-diffraction examination revealed a highly oriented film (fig. 2(b)).

REFERENCES

1. Good, J. N., and Godfrey, Douglas: Changes Found on Run-In and Scuffed Surfaces of Steel, Chrome Plate, and Cast Iron. NACA TN No. 1432, 1947.
2. Prutton, C. F., Turnbull, David, and Dlouhy, George: Mechanism of Action of Organic Chlorine and Sulfur Compounds in Extreme-Pressure Lubrication. Jour. Inst. of Petroleum, vol. 32, no. 266, Feb. 1946, pp. 90-118.
3. Hughes, T. P., and Whittingham, G.: The Influence of Surface Films on the Dry and Lubricated Sliding of Metals. Trans. Faraday Soc., vol. XXXVIII, pt. 1, no. 249, Jan. 1942, pp. 9-27.
4. Campbell, W. E.: Studies in Boundary Lubrication. Trans. A.S.M.E., vol. 61, no. 7, Oct. 1939, pp. 633-641.
5. Bowden, F. P., and Tabor, D.: The Lubrication by Thin Metallic Films and the Action of Bearing Metals. Jour. Appl. Phys., vol. 14, no. 3, March 1943, pp. 141-151.

6. Roensch, Max M.: Piston Ring Coatings and Their Effect on Ring and Bore Wear. S.A.E. Jour. (Trans.), vol. 6, no. 5, May 1940, pp. 221-228.
7. Merchant, M. Eugene: Characteristics of Typical Polar and Non-Polar Lubricant Additives under Stick-Slip Conditions. Lubr. Eng., vol. 2, no. 2, June 1946, pp. 56-61.
8. Powell, Allen S.: Reactions with Steel of Compounds Containing Chemical Groups Used in Lubricant Additives. NACA TN No. 1207, 1947.
9. Johnson, Robert L., Swikert, Max A., and Bisson, Edmond E.: Friction at High Sliding Velocities, NACA TN No. 1442, 1947.
10. Webb, Wells A.: The Influence of Iron Oxide on Wear of Rubbing Surfaces. Science, vol. 99, no. 2575, May 5, 1944, pp. 369-371.
11. Seitz, Frederick: Diffusion in Metals. Chap. XII of The Physics of Metals. McGraw-Hill Book Co., Inc., 1943, pp. 188-189.
12. Ernst, Hans, and Merchant, M. Eugene: Chip Formation, Friction, and High Quality Machined Surfaces. Surface Treatment of Metals. Am. Soc. Metals (Cleveland), 1941, pp. 299-335; discussion, pp. 337-378.
13. Bowden, F. P., and Ridler, K. W. E.: Physical Properties of Surfaces. III - The Surface Temperature of Sliding Metals. The Temperature of Lubricated Surfaces. Proc. Roy. Soc. (London), ser. A, vol. 154, no. 883, May 1, 1936, pp. 640-656.
14. Young, F. C., and Davis, B. B.: Scuff and Wear Resistant Chemical Coatings. Preprint of paper presented at S.A.E. Annual Meeting (Detroit), Jan. 6-10, 1947.
15. Walen, Ernest W., and Wilbur, Fowler W.: Process for Imparting Color Finish to Ferrous Metal Articles. U.S. Patent Office No. 2,192,280, March 5, 1940.
16. Norman, T. E.: Molybdenite as a Die Lubricant. Metal Progress, vol. 50, no. 2, Aug. 1946, p. 314.
17. Bell, M. E. and Findlay, J. H.: Molybdenite as a New Lubricant. The Phys. Rev., vol. 59, no. 11, June 1, 1941, p. 922.

18. Boyd, John, and Robertson, B. P.: The Friction Properties of Various Lubricants at High Pressures. Trans. A.S.M.E. vol. 67, no. 1, Jan. 1945, pp. 51-56; discussion, pp. 56-59.
19. Van Brunt, C., and Savage, R. H.: Carbon-Brush Contact Films: Part I. Gen. Electric Rev., vol. 47, no. 7, July 1944, pp. 16-19.

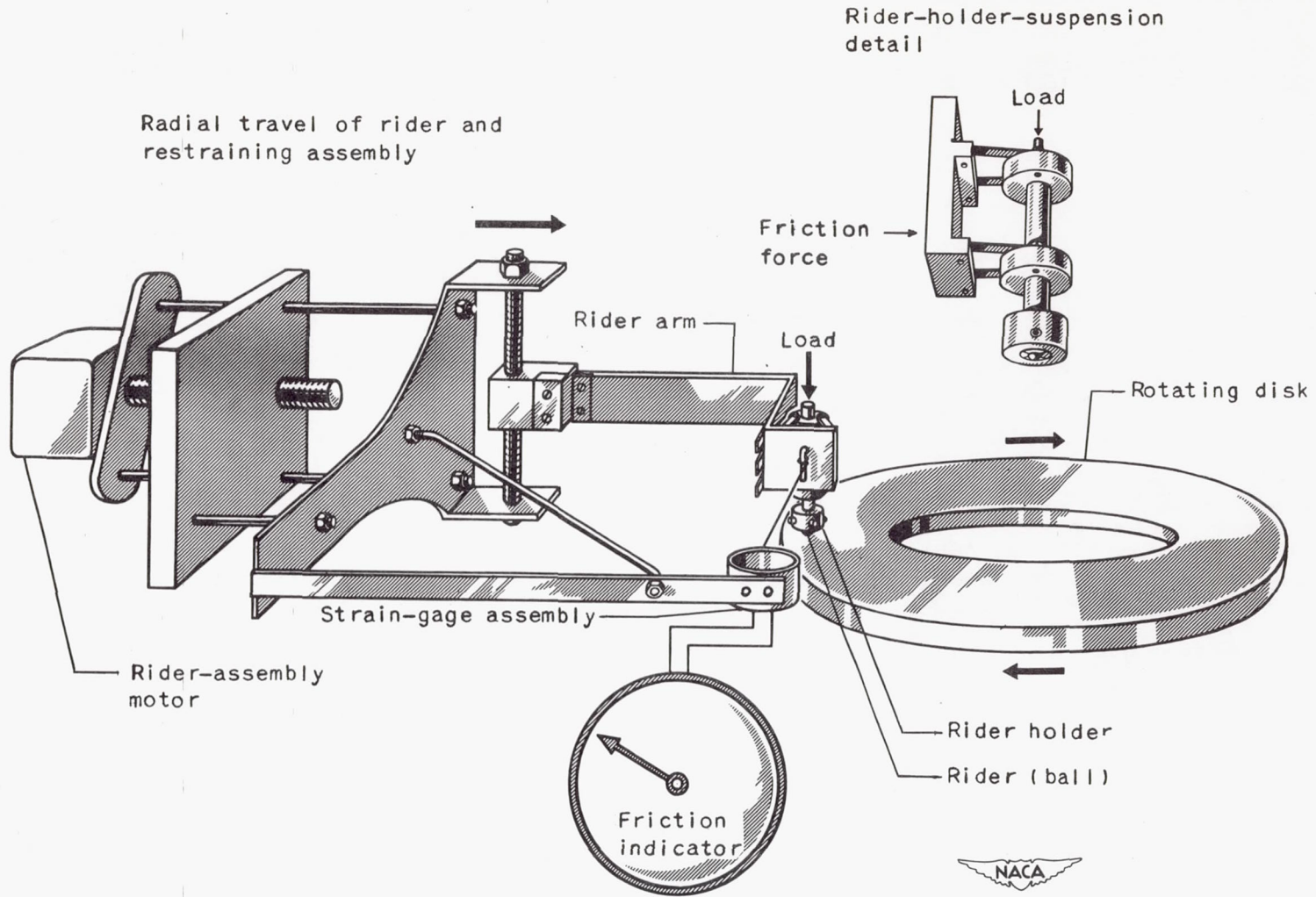
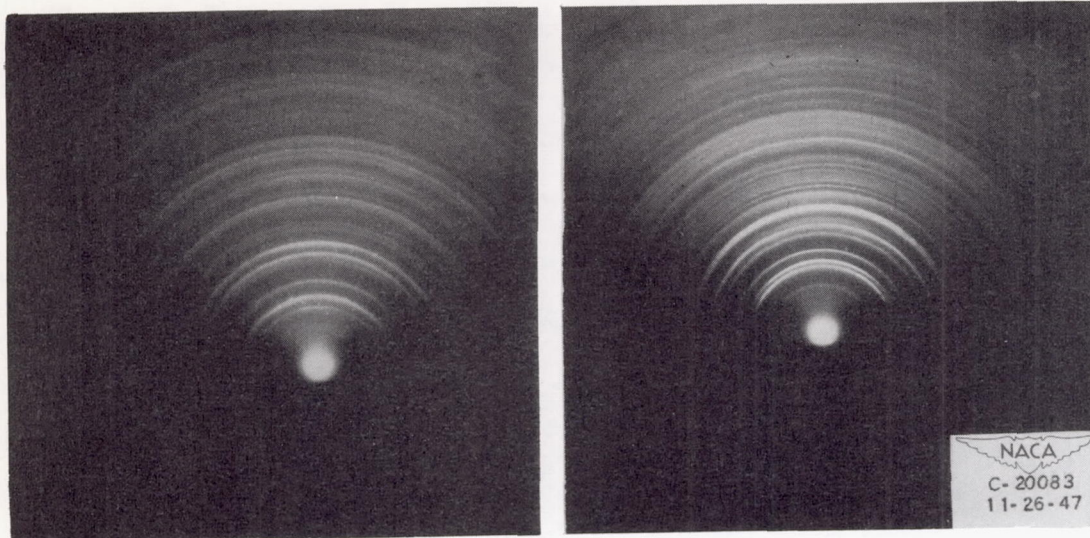

Figure 1. - Schematic diagram of sliding-friction apparatus.



[d, interplanar distance in Angstrom units (A); I/I₀, A.S.T.M. X-ray standard pattern intensity ratio; vs, very strong; s, strong; fs, fairly strong; fw, fairly weak; w, weak; vw, very weak]

Film prepared as Fe ₃ O ₄		A.S.T.M. standard X-ray pattern for Fe ₃ O ₄	
d (A)	Relative intensity	d (A)	I/I ₀
4.95	fw	4.85	0.06
4.53	w	----	----
3.05	fs	2.97	.28
2.58	vs	2.53	1.00
2.45	w	2.42	.11
2.14	s	2.10	.32
1.965	w	----	----
1.734	fw	1.71	.16
1.650	fs	1.61	.64
1.510	fs	1.483	.80
1.434	vw	----	----
1.341	w	1.326	.06
1.293	fw	1.279	.20
1.222	w	1.210	.05
1.139	fw	1.121	.10
1.104	fs	1.092	.32
1.066	vw	1.049	.10
.980	w	.970	.16
.950	fw	.966	.08
.892	w	.880	.10
.867	fw	.859	.20
----	--	.853	.08
.824	w	.825	.02

(a) Ferroso-ferric oxide Fe₃O₄.

Film prepared as α-Fe ₂ O ₃		A.S.T.M. standard X-ray pattern for α-Fe ₂ O ₃	
d (A)	Relative intensity	d (A)	I/I ₀
3.71	fs	3.68	0.18
2.71	s	2.69	1.00
2.52	vs	2.51	.75
2.21	s	2.20	.18
2.10	vw	----	----
1.840	s	1.84	.63
1.690	s	1.69	.63
1.630	w	----	----
1.597	w	1.60	.13
1.478	s	1.485	.50
1.450	s	1.452	.50
----	-	1.351	.03
1.310	w	1.308	.18
1.247	w	1.259	.13
1.211	w	1.230	.03
1.190	w	1.190	.08
----	-	1.163	.05
1.138	w	1.140	.13
1.103	w	1.104	.10
1.055	vw	1.056	.08
.990	vw	.962	.10

(b) Ferric oxide α-Fe₂O₃.

Figure 2. - Electron-diffraction patterns and analysis data from solid films formed on SAE 1020 steel.

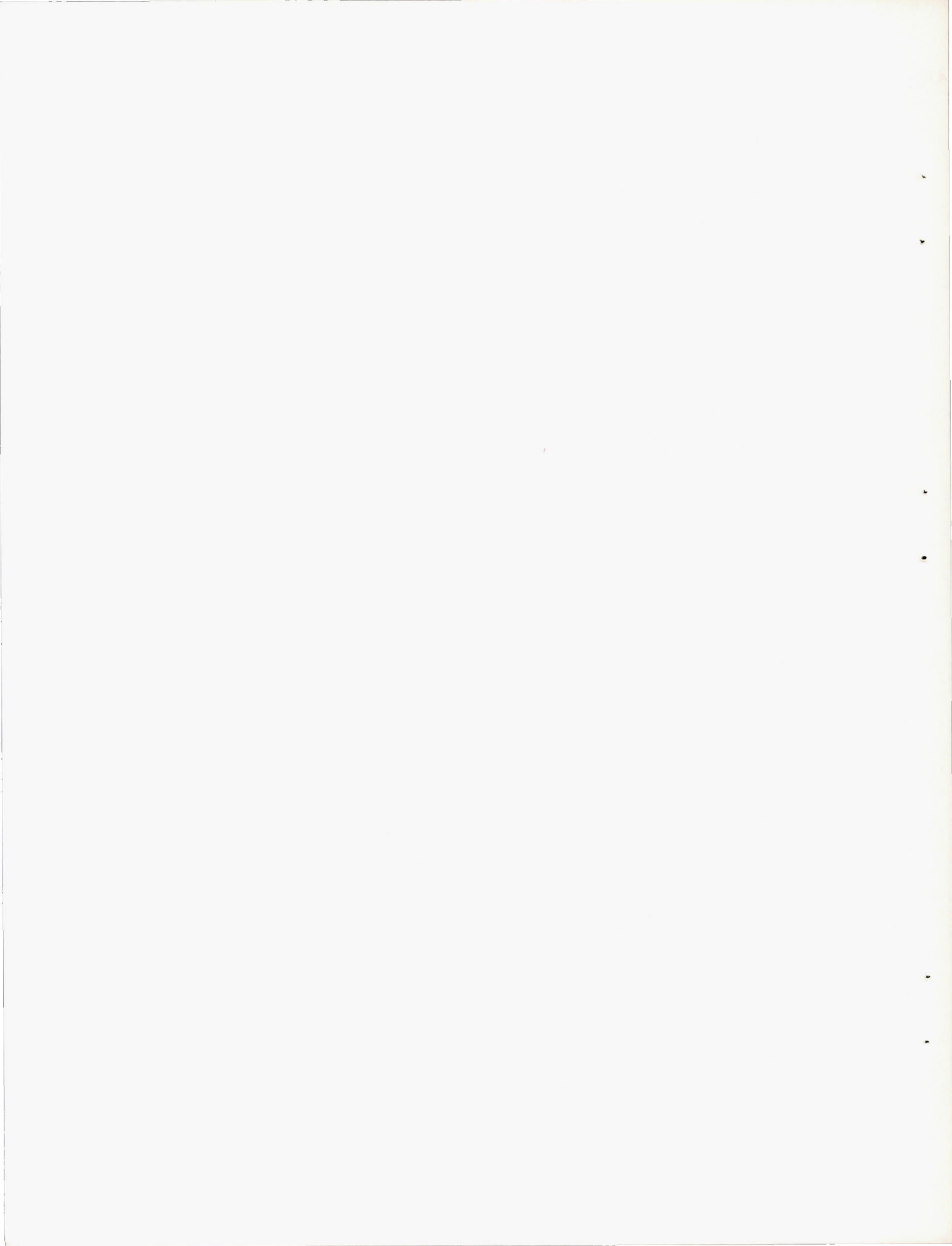

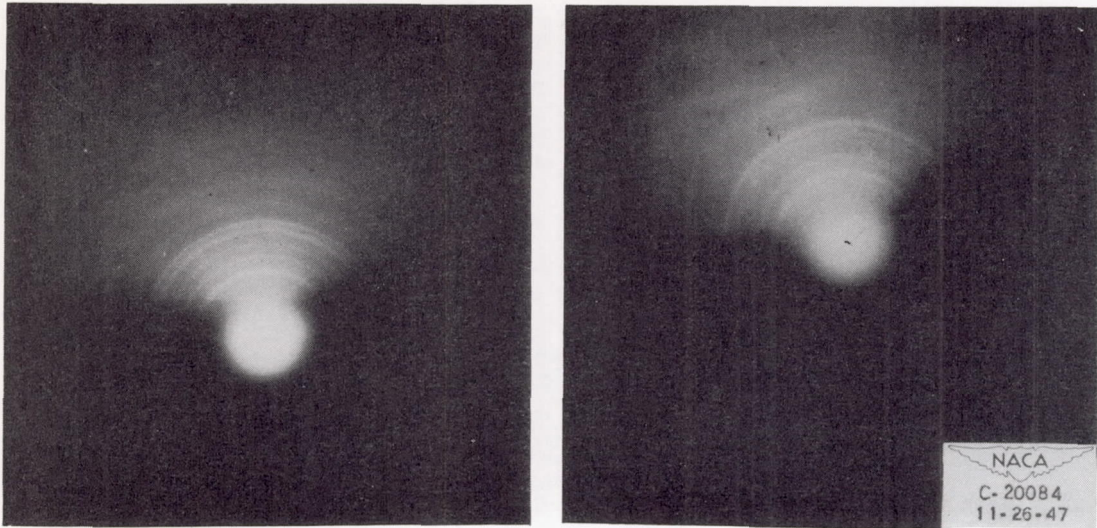

[d, interplanar distance in Angstrom units (A); I/I₀, A.S.T.M. X-ray standard pattern intensity ratio; vs, very strong; s, strong; fs, fairly strong; fw, fairly weak; w, weak; vw very weak]

Film prepared by caustic-sulphur treatment		A.S.T.M. standard X-ray pattern for Fe ₃ O ₄		Film prepared by caustic-potassium nitrate treatment	
d (A)	Relative intensity	d (A)	I/I ₀	d (A)	Relative intensity
-----	--	4.85	0.06	-----	--
2.99	w	2.97	.28	2.97	fs
2.55	vs	2.53	1.00	2.54	vs
-----	--	2.42	.11	-----	--
2.12	s	2.10	.32	2.07	s
1.830	s	-----	-----	-----	--
-----	--	1.710	.16	-----	--
1.620	fs	1.610	.64	1.610	fs
1.590	w	-----	-----	-----	--
1.485	vs	1.483	.80	1.469	vs
-----	--	1.326	.06	-----	--
1.277	w	1.279	.20	1.292	w
1.216	vw	1.210	.05	-----	--
-----	--	1.121	.10	1.160	vw
1.092	fs	1.092	.32	-----	--
1.042	vw	1.049	.10	1.074	w
-----	--	.970	.16	.965	vw
-----	--	.966	.08	-----	--
-----	--	.880	.10	-----	--
.854	fw	.859	.20	-----	--

(c) Caustic-sulphur treatment Fe₃O₄.

(d) Caustic-potassium nitrate treatment Fe₃O₄.

Figure 2. - Continued. Electron-diffraction patterns and analysis data from solid films formed on SAE 1020 steel.

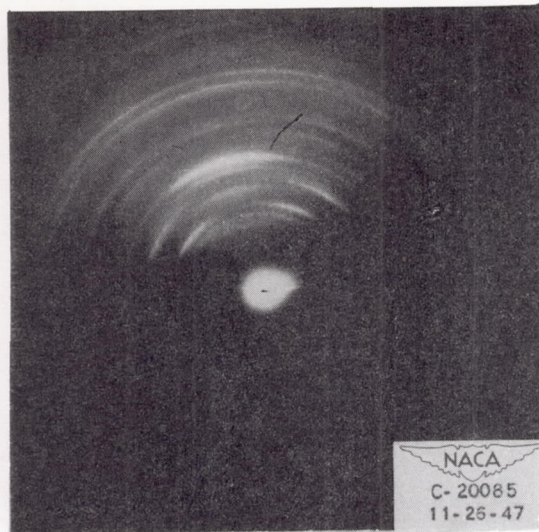

[d, interplanar distance in Angstrom units (A); I/I₀, A.S.T.M. X-ray standard pattern intensity ratio; vs, very strong; s, strong; fs, fairly strong; fw, fairly weak; w, weak; vw, very weak]

Film prepared as FeCl ₂		A.S.T.M. standard X-ray pattern for FeCl ₂	
d (A)	Relative intensity	d (A)	I/I ₀
5.70	w	5.80	0.63
4.40	vw	----	----
2.93	vs	3.06	.30
2.64	vs	2.54	1.00
2.35	fs	2.32	.07
2.11	s	2.09	.07
----	--	1.950	.13
1.82	s	1.796	.63
1.70	s	1.718	.13
1.61	w	1.630	.02
----	--	1.550	.04
1.38	w	1.464	.20
----	--	1.410	.05

Film prepared as FeS		A.S.T.M. standard X-ray pattern for FeS	
d (A)	Relative intensity	d (A)	I/I ₀
4.73	vw	----	----
2.98	fw	2.97	0.33
----	--	2.88	.04
2.67	s	2.65	.33
2.46	vs	----	----
2.21	fs	----	----
2.06	vs	2.06	1.00
1.86	fw	----	----
1.725	vs	1.71	.33
1.615	fw	1.61	.07
1.55	--	1.48	.04
1.443	w	1.442	.09
1.371	w	----	----
1.310	fw	1.321	.13
----	--	1.299	.05
1.183	vw	1.179	.01
1.099	fs	1.105	.13
1.080	fs	----	----
1.040	vw	1.050	.07
----	--	.995	.01
.968	vw	----	----
.949	w	----	----
.867	w	----	----
.817	w	----	----

(e) Ferrous chloride FeCl₂.

(f) Ferrous sulfide FeS.

Figure 2. - Continued. Electron-diffraction patterns and analysis date from solid films formed on SAE 1020 steel.



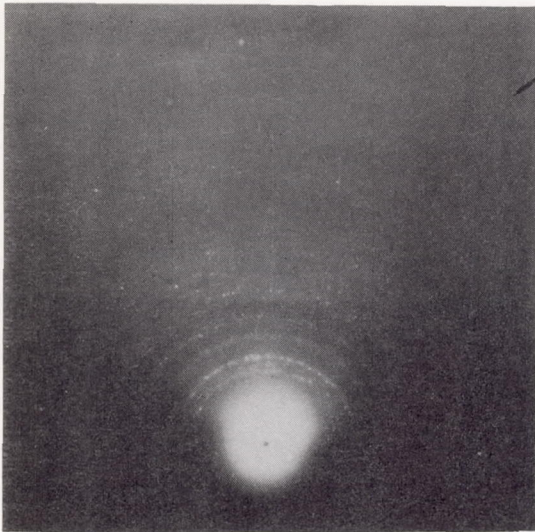

[\bar{d} , interplanar distance in Angstrom units (A); I/I_0 , A.S.T.M. X-ray standard pattern intensity ratio; vs, very strong; s, strong; fs, fairly strong; fw, fairly weak; w, weak; vw, very weak]

Film prepared as MoS ₂		A.S.T.M. standard X-ray pattern for MoS ₂	
d (A)	Relative intensity	d (A)	I/I ₀
----	--	6.61	0.80
----	--	5.63	.90
2.78	s	2.74	.70
2.58	fs	2.66	.30
2.46	fs	2.49	.50
2.28	vs	2.27	1.00
----	--	2.040	.70
1.854	s	1.820	1.00
1.639	fs	1.635	.30
1.570	fs	1.578	.70
1.520	fs	1.530	.90
----	--	1.475	.20
1.370	fs	1.365	.20
----	--	1.335	.70
1.300	s	1.295	.70
1.252	fw	1.251	.70
1.206	w	1.222	.20
		1.195	.50
1.090	w	1.100	.70
1.030	w	1.034	.80
----	--	1.021	.50
1.002	fs	1.002	.70
.993	fw	----	----
----	--	.968	.30

The pattern from oriented graphite is composed of true Bragg spots, which represent a series of orders of the (002) spacing along a line perpendicular to shadow edge of specimen.

(g) Molybdenum disulfide MoS₂.

(h) Graphitic carbon C.

Figure 2. - Concluded. Electron-diffraction patterns and analysis data from solid films formed on SAE 1020 steel.

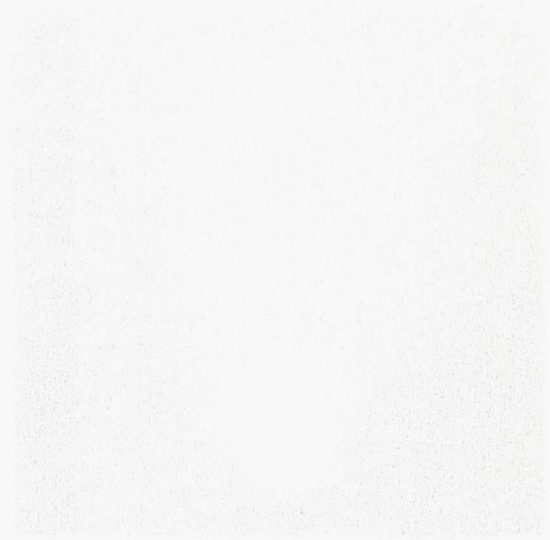
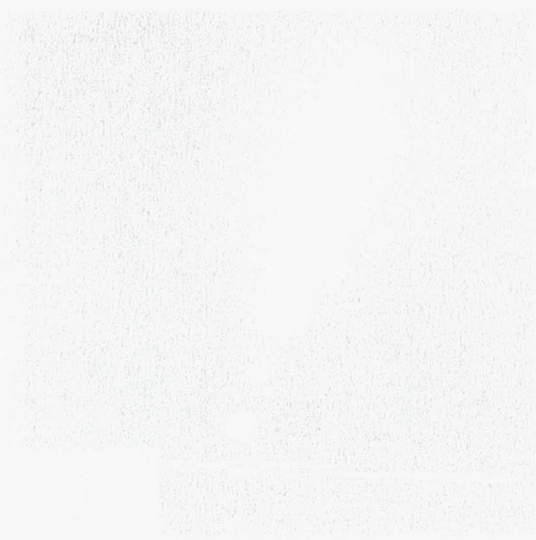

THE ABOVE IS A COPY OF THE ORIGINAL DOCUMENT AS SUBMITTED TO THE BUREAU OF INVESTIGATION ON APRIL 15, 1954.

THIS IS A COPY OF THE ORIGINAL DOCUMENT AS SUBMITTED TO THE BUREAU OF INVESTIGATION ON APRIL 15, 1954.

THE ABOVE IS A COPY OF THE ORIGINAL DOCUMENT AS SUBMITTED TO THE BUREAU OF INVESTIGATION ON APRIL 15, 1954.

NO.	NAME	ADDRESS	CITY	STATE	ZIP
1
2
3
4
5
6
7
8
9
10
11
12
13
14
15
16
17
18
19
20
21
22
23
24
25
26
27
28
29
30
31
32
33
34
35
36
37
38
39
40
41
42
43
44
45
46
47
48
49
50

THIS IS A COPY OF THE ORIGINAL DOCUMENT AS SUBMITTED TO THE BUREAU OF INVESTIGATION ON APRIL 15, 1954.

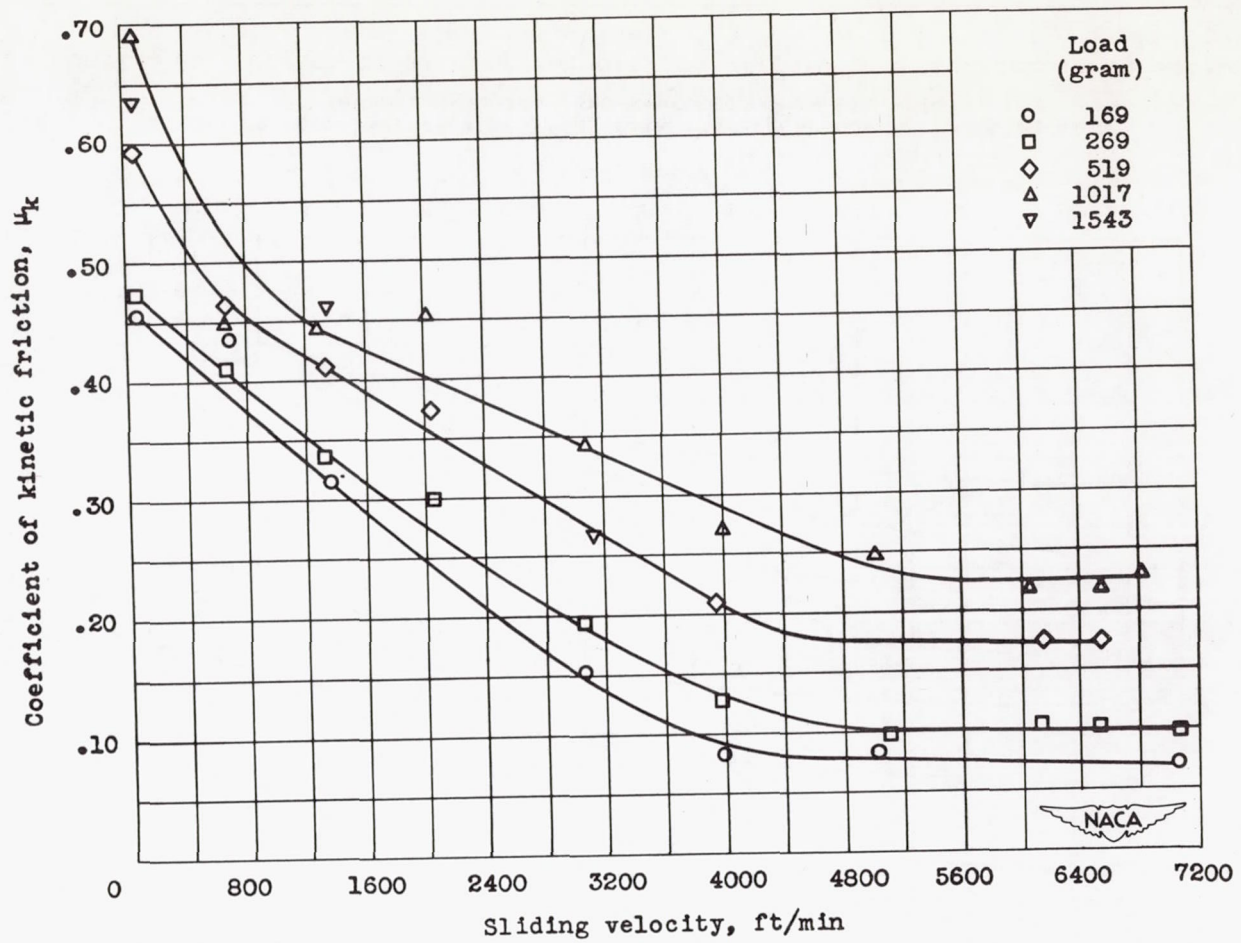

(a) Ferrous-ferric oxide Fe_3O_4 film showing that friction is not independent of load.

Figure 3. - Effect of sliding velocity on friction for surfaces with solid films of oxides.

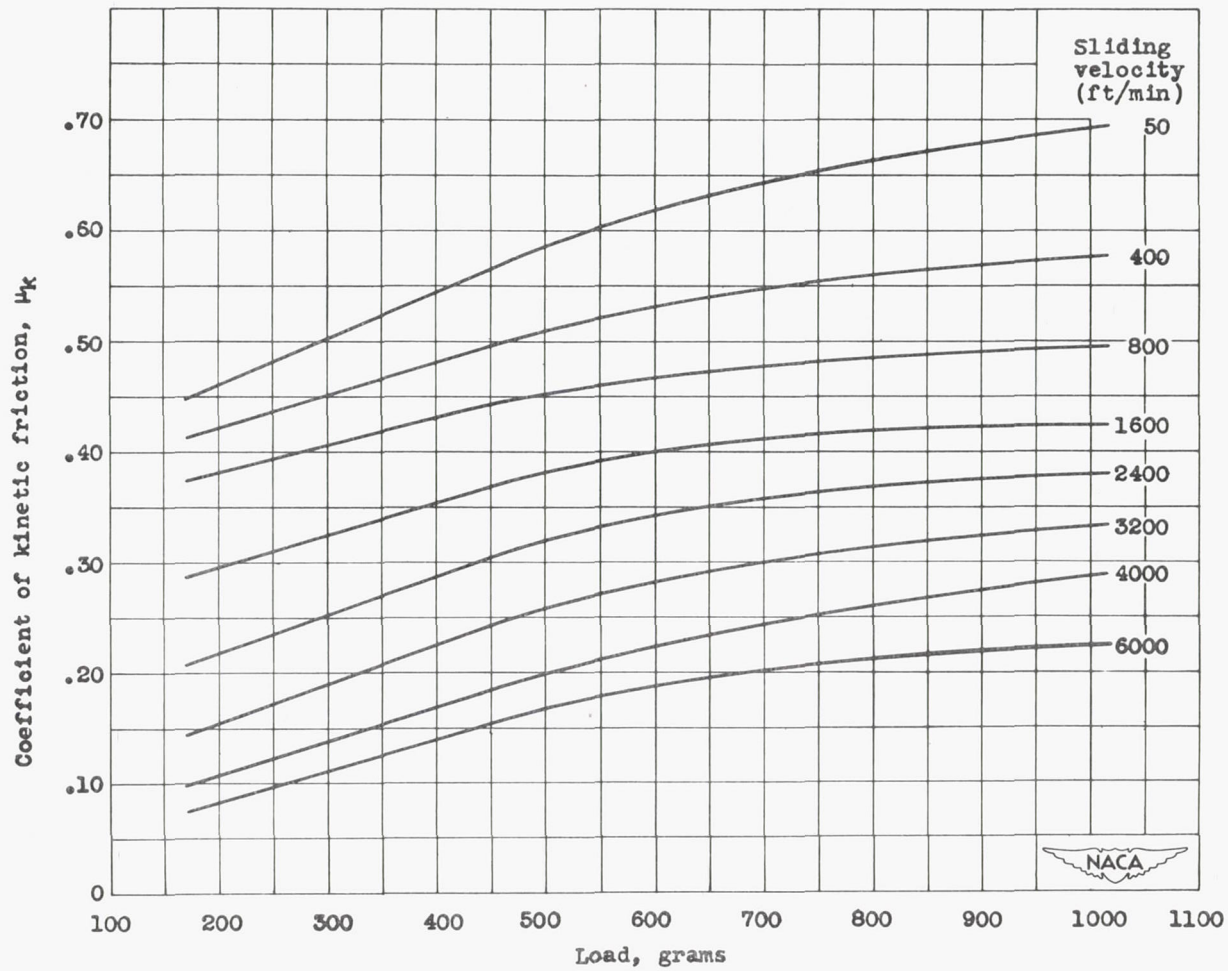

(b) Ferrous-ferric oxide Fe_3O_4 film showing trends of friction with increasing loads (cross-plotted from fig. 3(a)).

Figure 3. - Continued. Effect of sliding velocity on friction for surfaces with solid films of oxides.

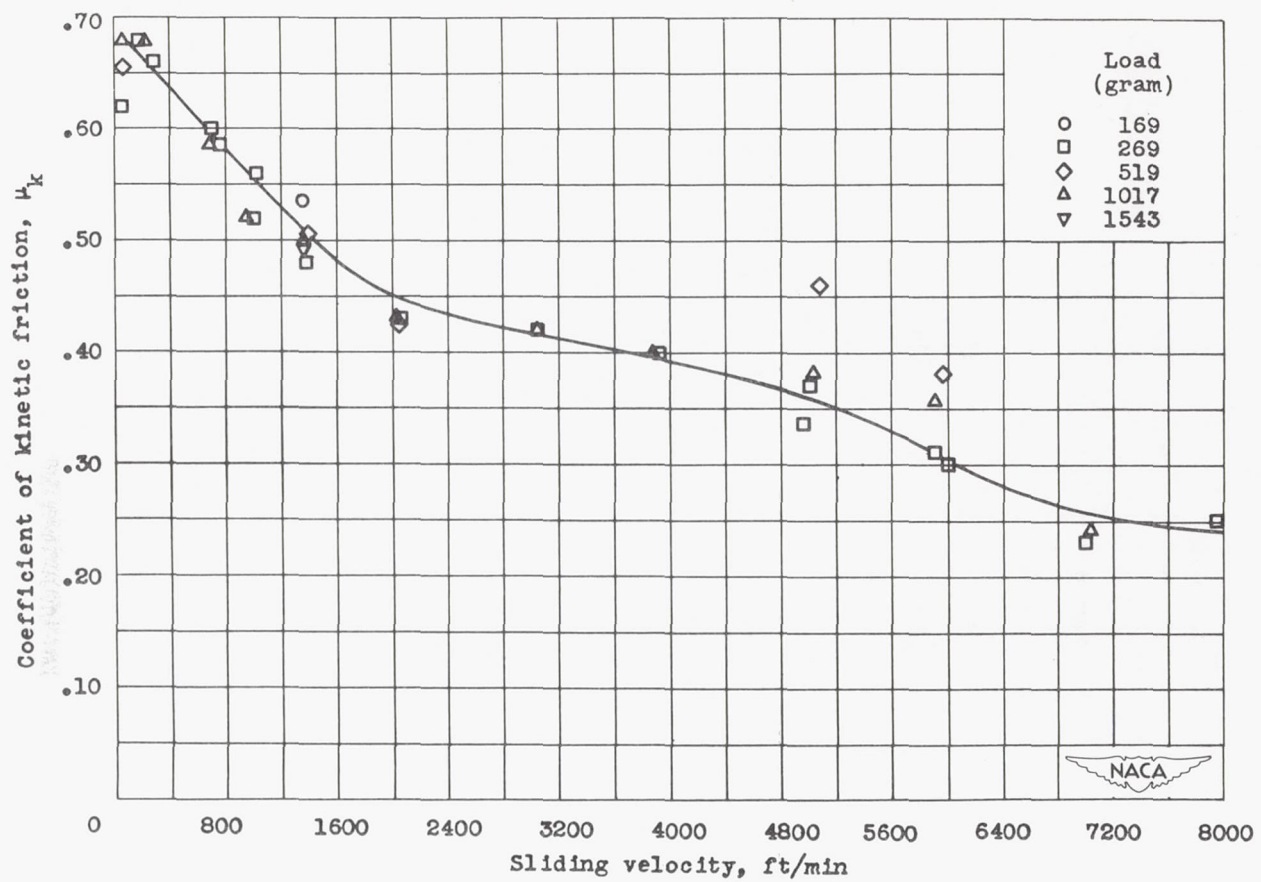

(c) Ferric oxide $\alpha\text{-Fe}_2\text{O}_3$ film showing that friction is essentially independent of load.

Figure 3. - Continued. Effect of sliding velocity on friction for surfaces with solid films of oxides.

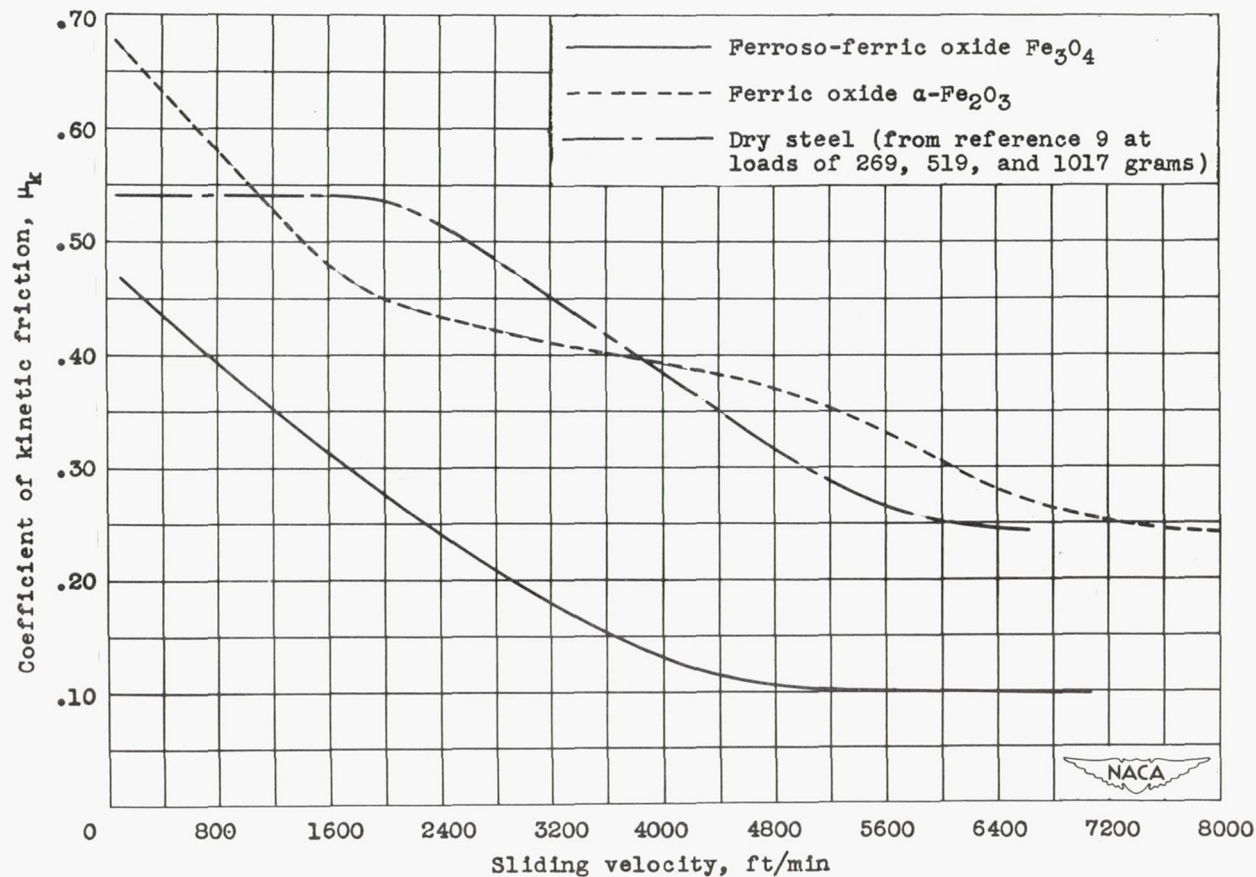

(d) Ferroso-ferric-oxide Fe_3O_4 and ferric-oxide $\alpha\text{-Fe}_2\text{O}_3$ films with loads of 269 grams.

Figure 3. - Concluded. Effect of sliding velocity on friction for surfaces with solid films of oxides.

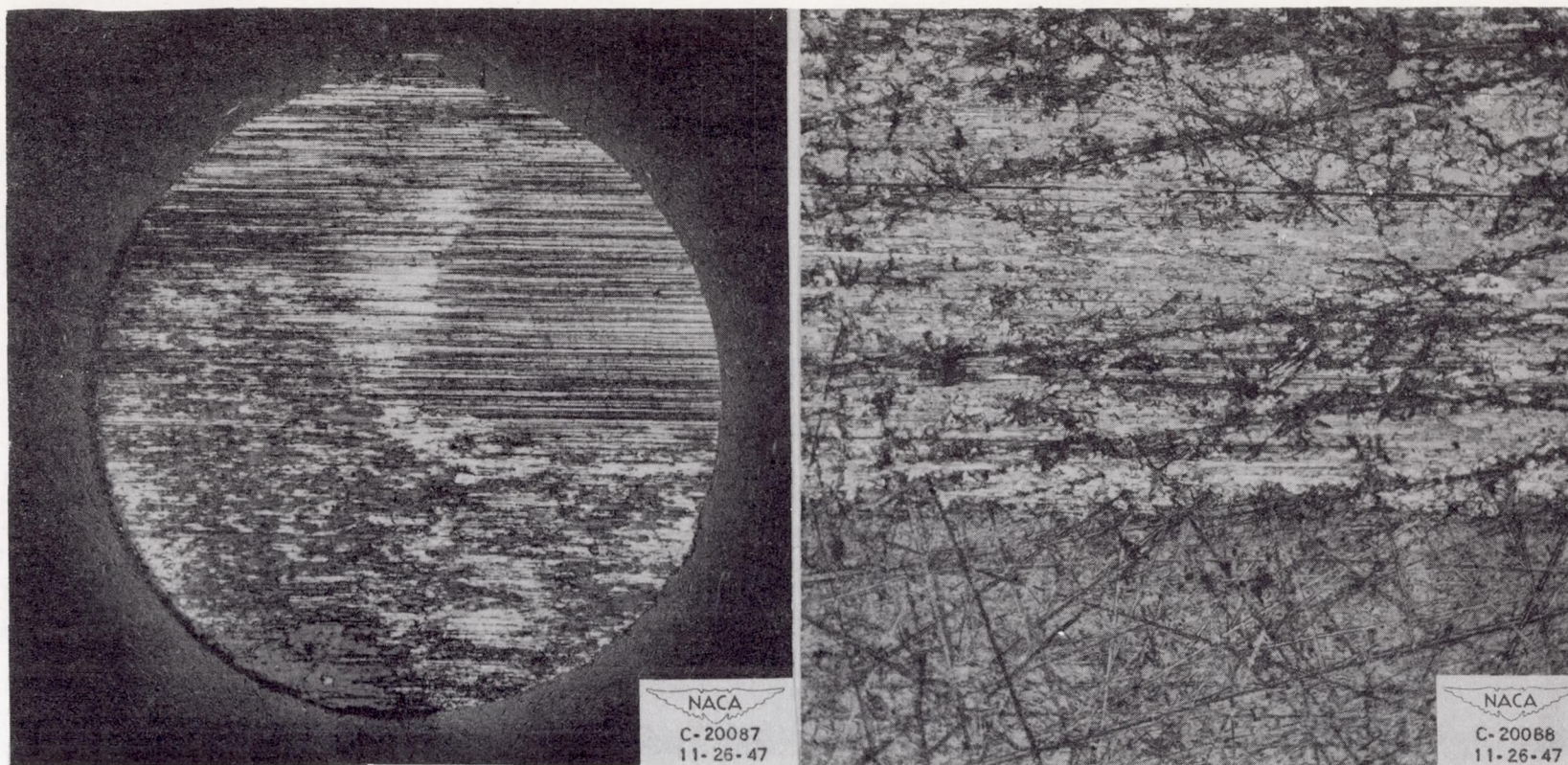

(a) Wear spot on spherical rider;
kinetic friction μ_k , 0.30;
wear-spot diameter, 0.034 inch.
(Mating surface shown in fig. 4(b).)

(b) Wear track on disk specimen with
ferroso-ferric-oxide Fe_3O_4 film.
(Mating surface shown in fig. 4(a).)

Figure 4. - Photomicrographs of wear areas after operation for 6 seconds at 2000 feet per minute with 269 grams load on SAE 1020 steel having oxide films. x100.

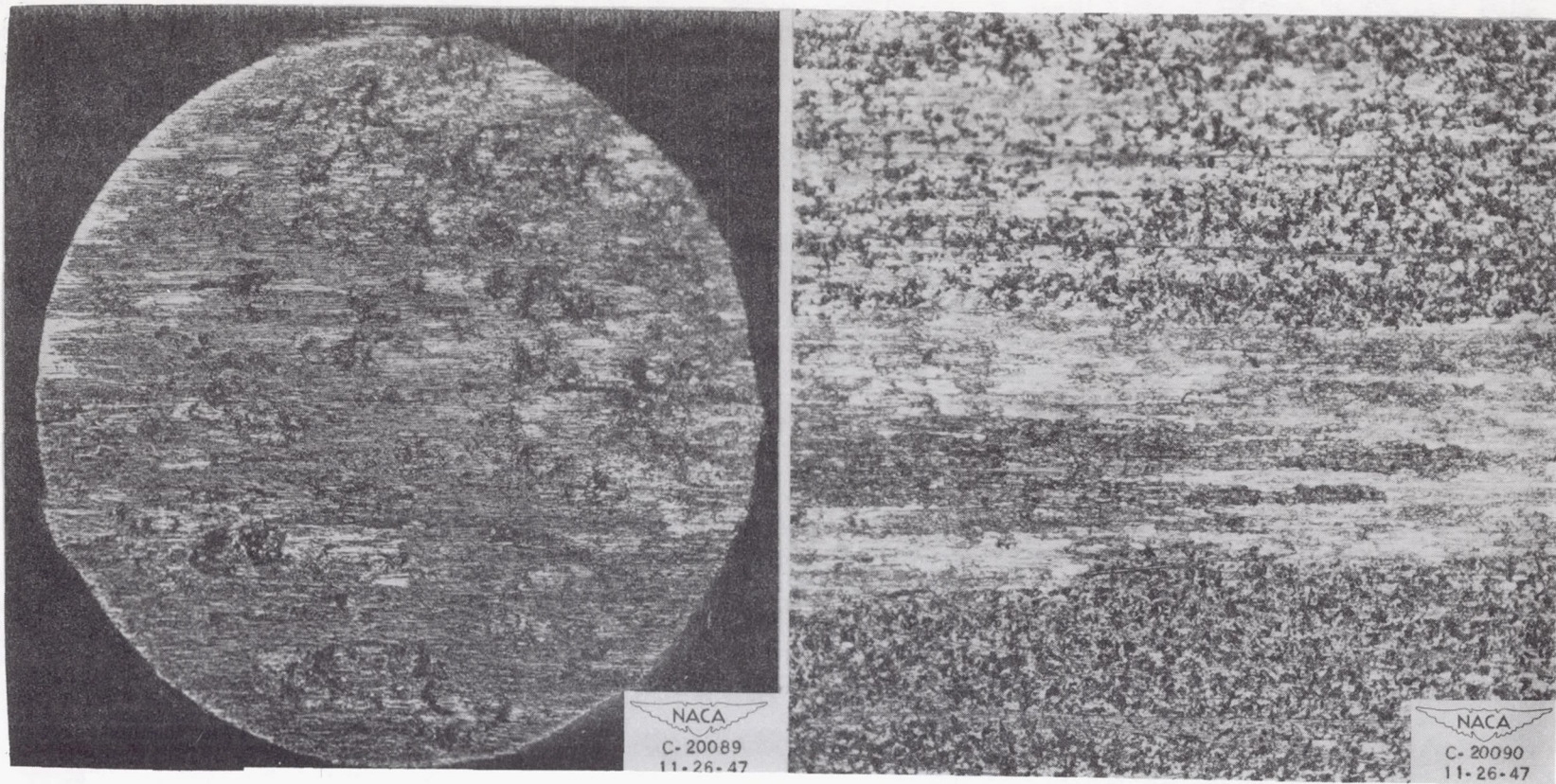

(c) Wear spot on spherical rider;
kinetic friction μ_k , 0.43;
wear-spot diameter, 0.040 inch.
(Mating surface shown in fig. 4(d).)

(d) Wear track on disk specimen with
ferric-oxide $\alpha\text{-Fe}_2\text{O}_3$ film.
(Mating surface shown in fig. 4(c).)

Figure 4. - Concluded. Photomicrographs of wear areas after operation for 6 seconds at 2000 feet per minute with 269 grams load on SAE 1020 steel having oxide films. x100.

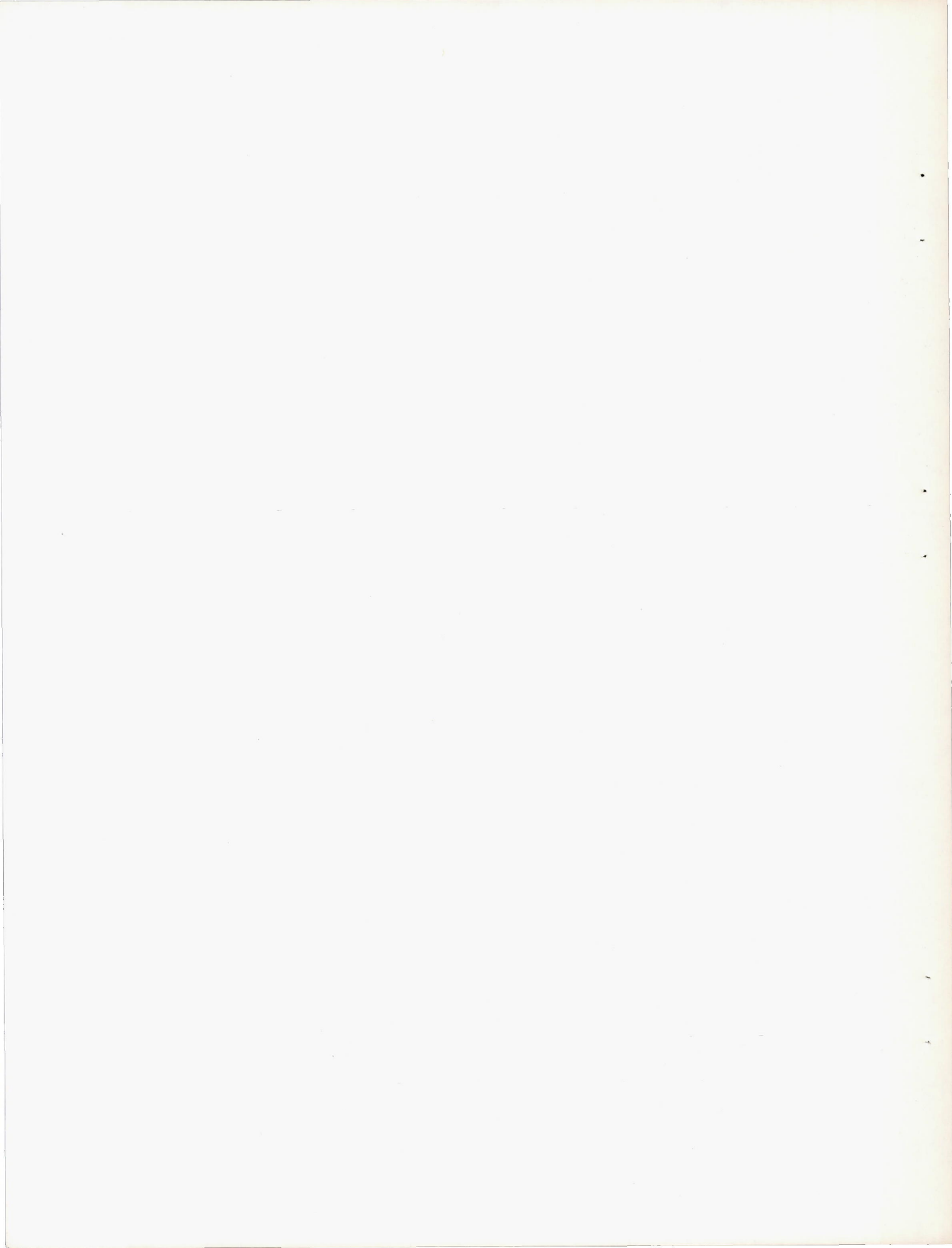

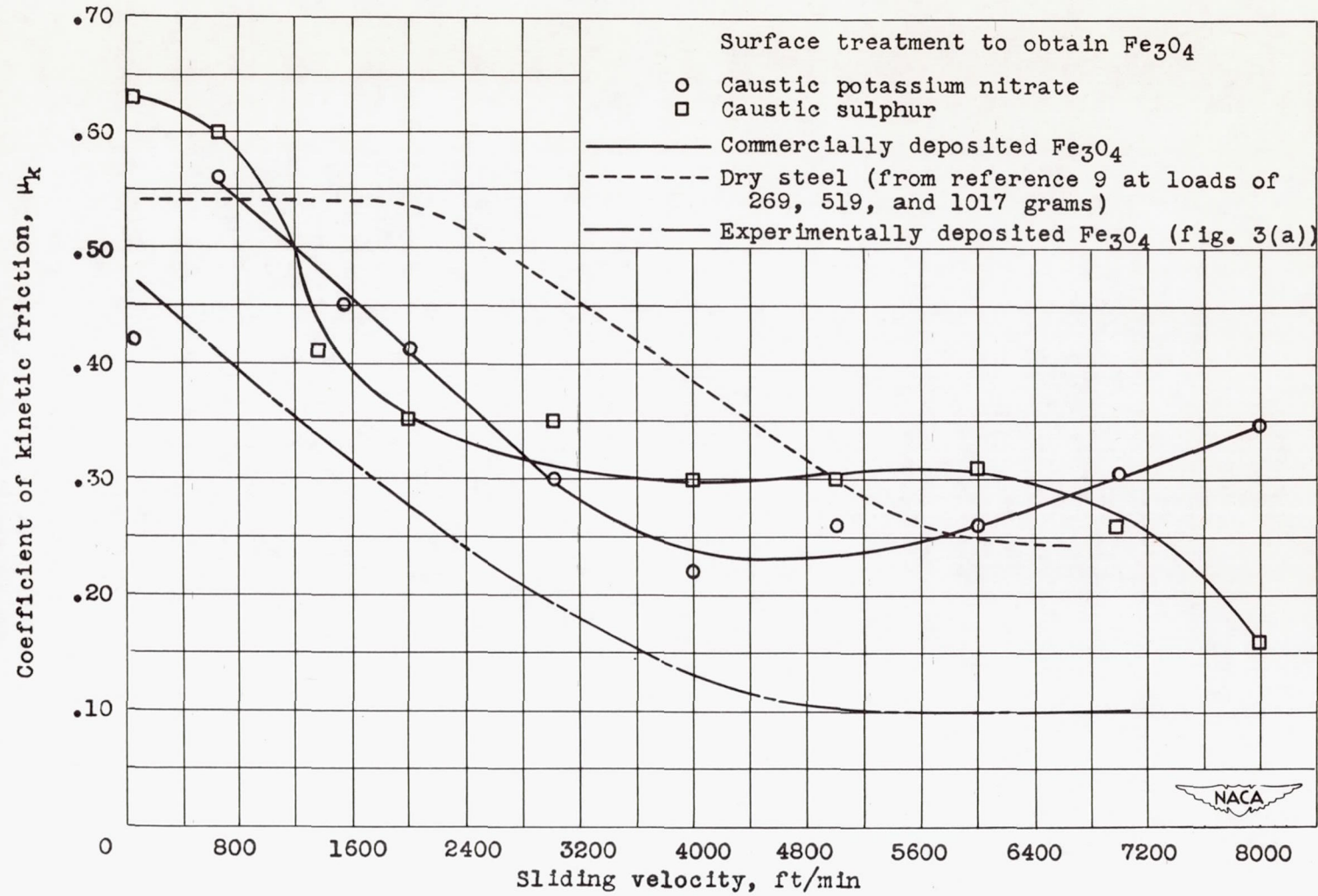
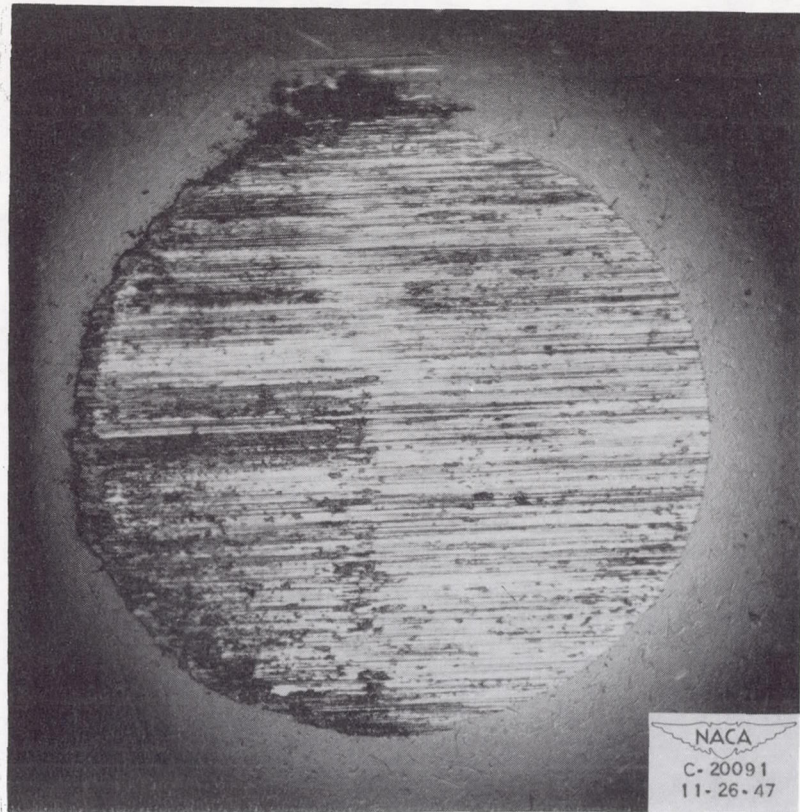
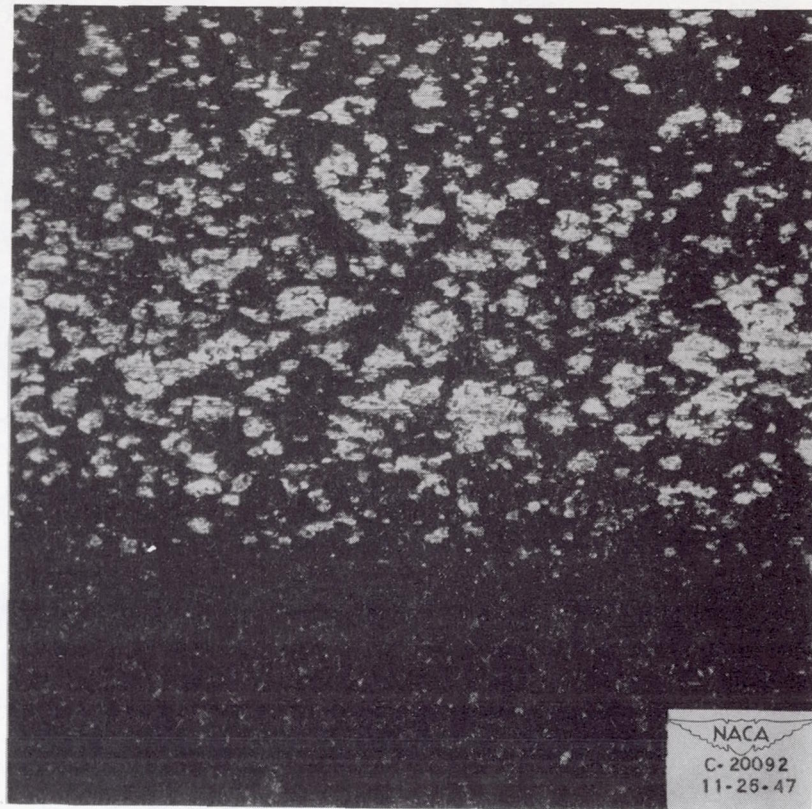

Figure 5. - Effect of sliding velocity on friction for surfaces with solid films of ferrous-ferrous oxide Fe₃O₄ formed by commercial (caustic soda) treatments. Load, 269 grams. Friction essentially independent of load.





(a) Wear spot on spherical rider;
kinetic friction μ_k , 0.35;
wear-spot diameter, 0.033 inch.
(Mating surface shown in fig. 6(b).)



(b) Wear track on disk specimen treated
in caustic-sulphur solution to form
film of ferrous-ferric oxide Fe_3O_4 .
(Mating surface shown in fig. 6(a).)

Figure 6. - Photomicrographs of wear areas after operation for 6 seconds at 2000 feet per minute with 269 grams load on SAE 1020 steel disks having films that are predominately ferrous-ferric oxide Fe_3O_4 formed by commercial treatments. x100.

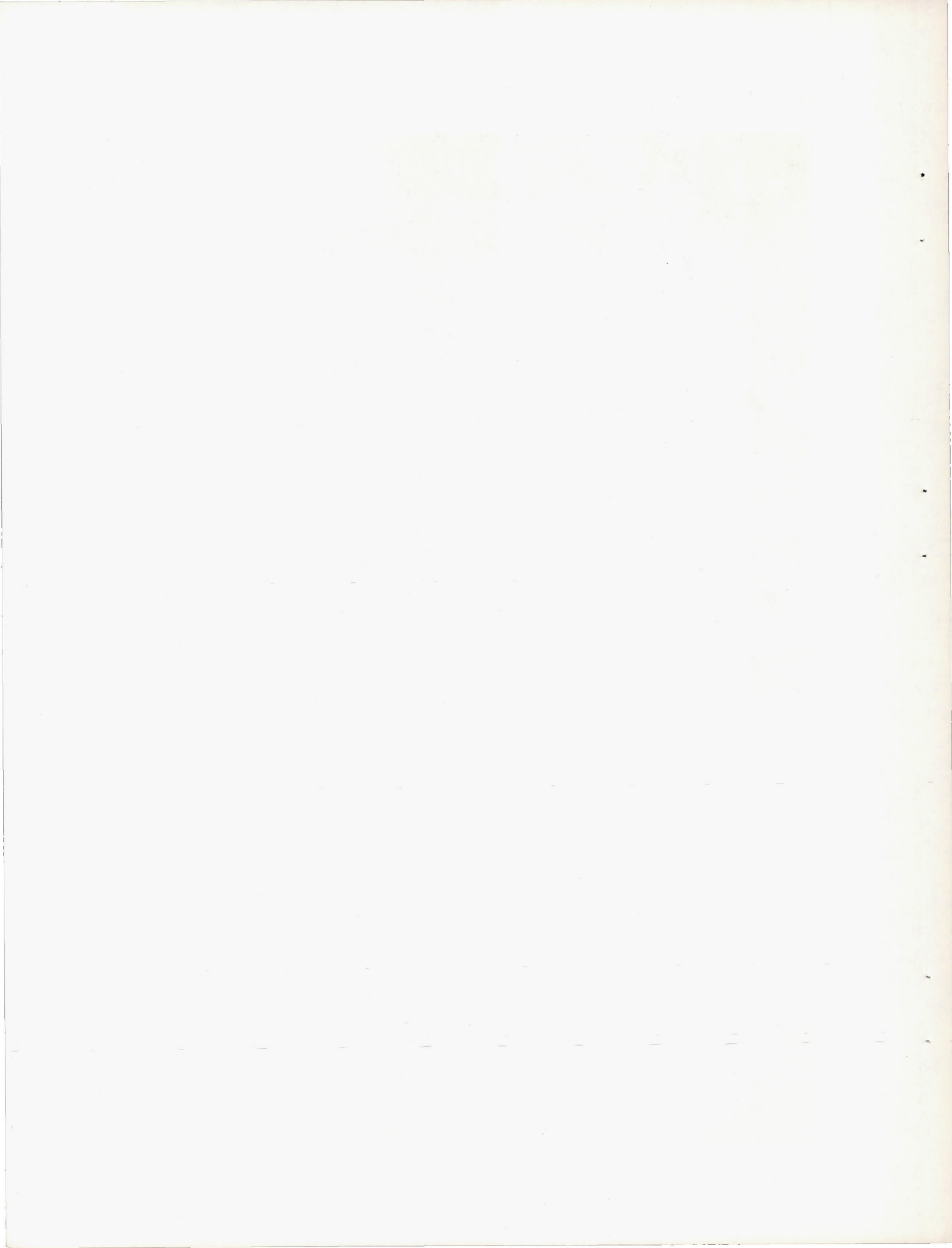

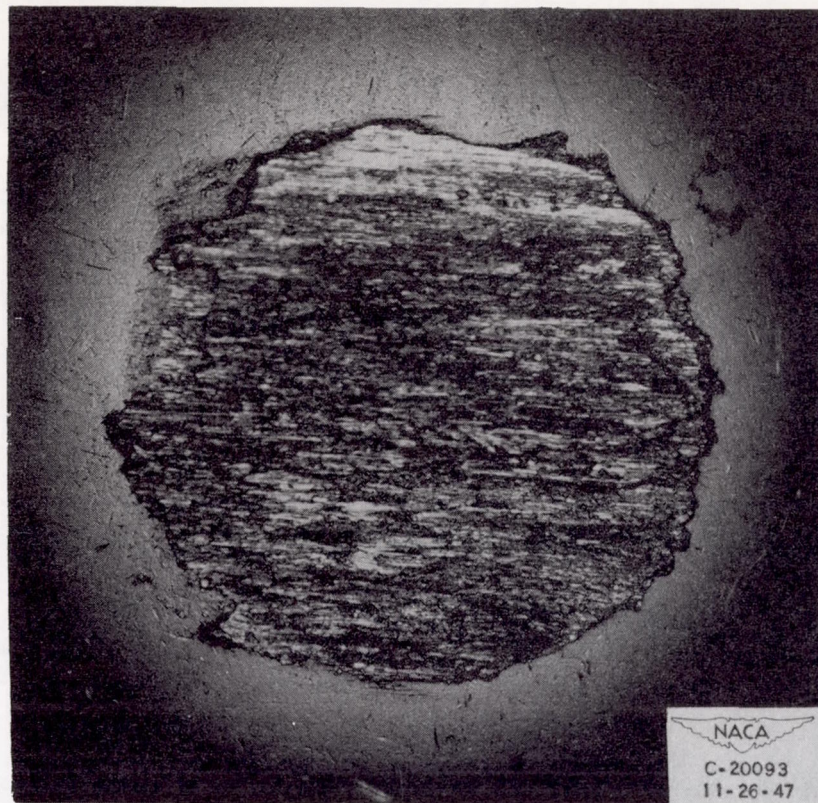

(c) Wear spot on spherical rider;
kinetic friction μ_k , 0.41;
wear-spot diameter, 0.030 inch.
(Mating surface shown in fig. 6(d).)

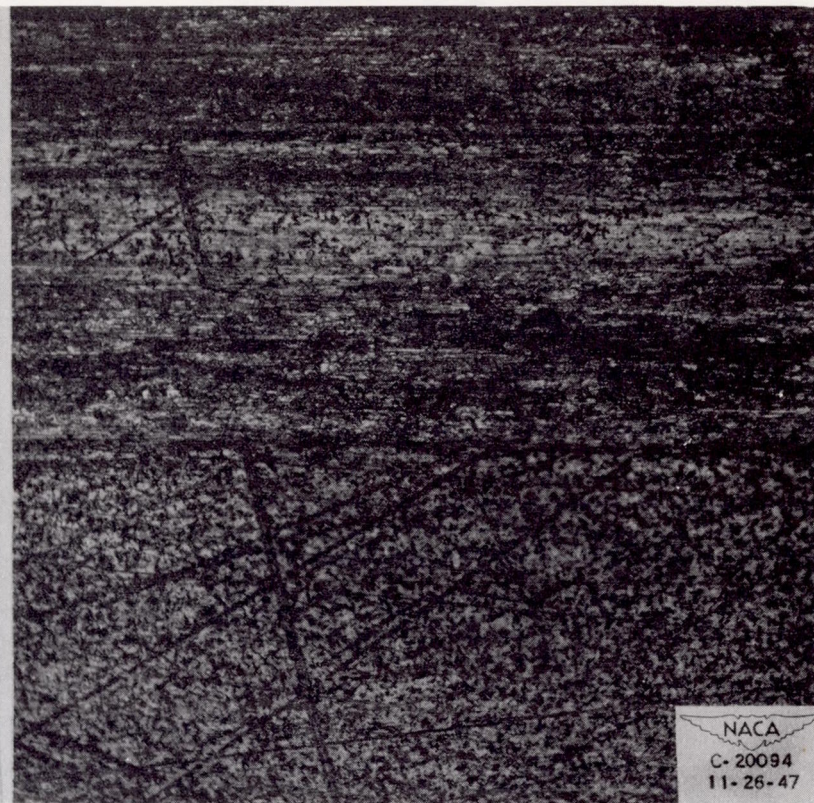

(d) Wear track on disk specimen treated
in caustic potassium nitrate solution
to form film of ferroso-ferric oxide
 Fe_3O_4 . (Mating surface shown in
fig. 6(c).)

Figure 6. - Concluded. Photomicrographs of wear areas after operation for 6 seconds at 2000 feet per minute with 269 grams load on SAE 1020 steel disks having films that are predominately ferroso-ferric oxide Fe_3O_4 formed by commercial treatments. $\times 100$.

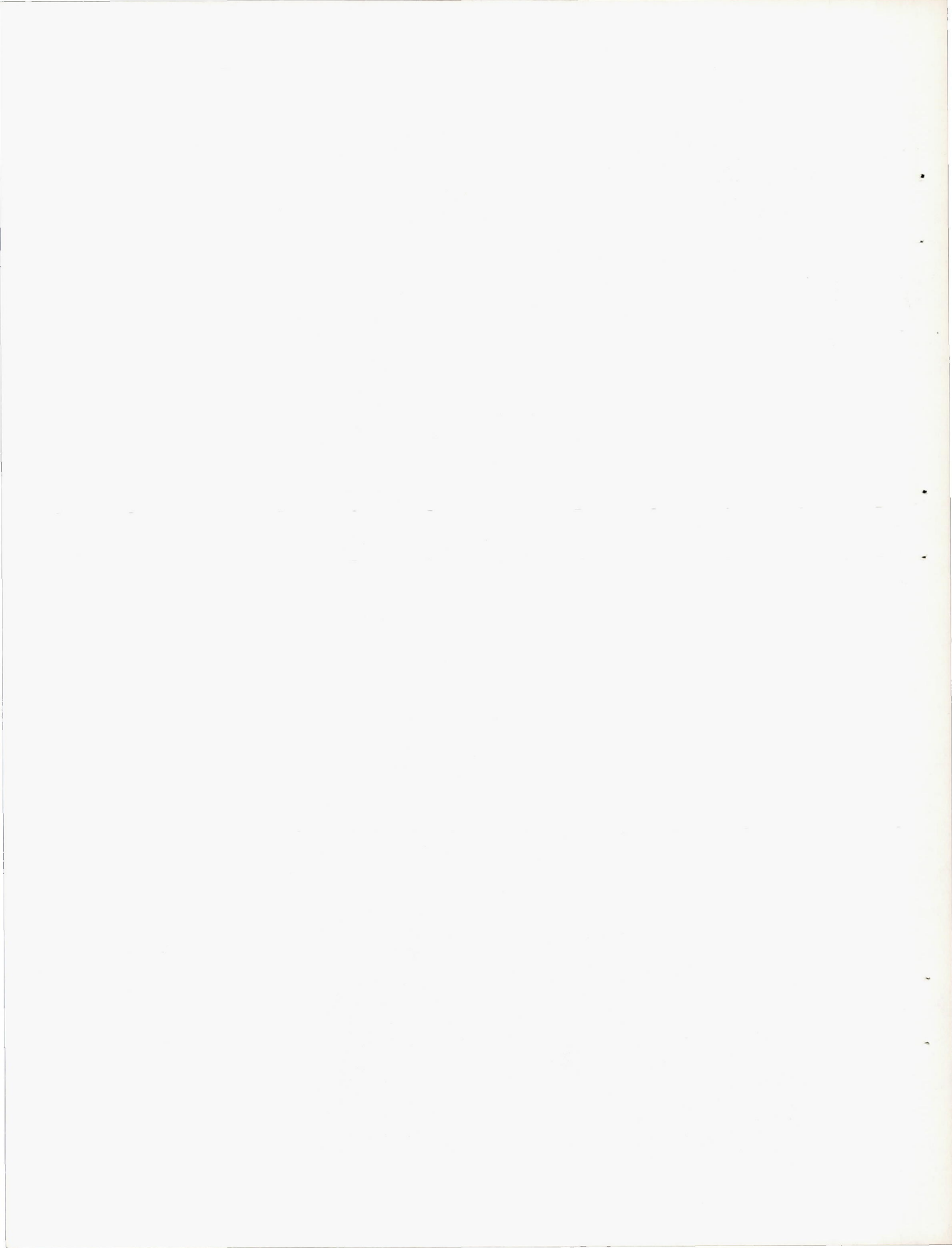

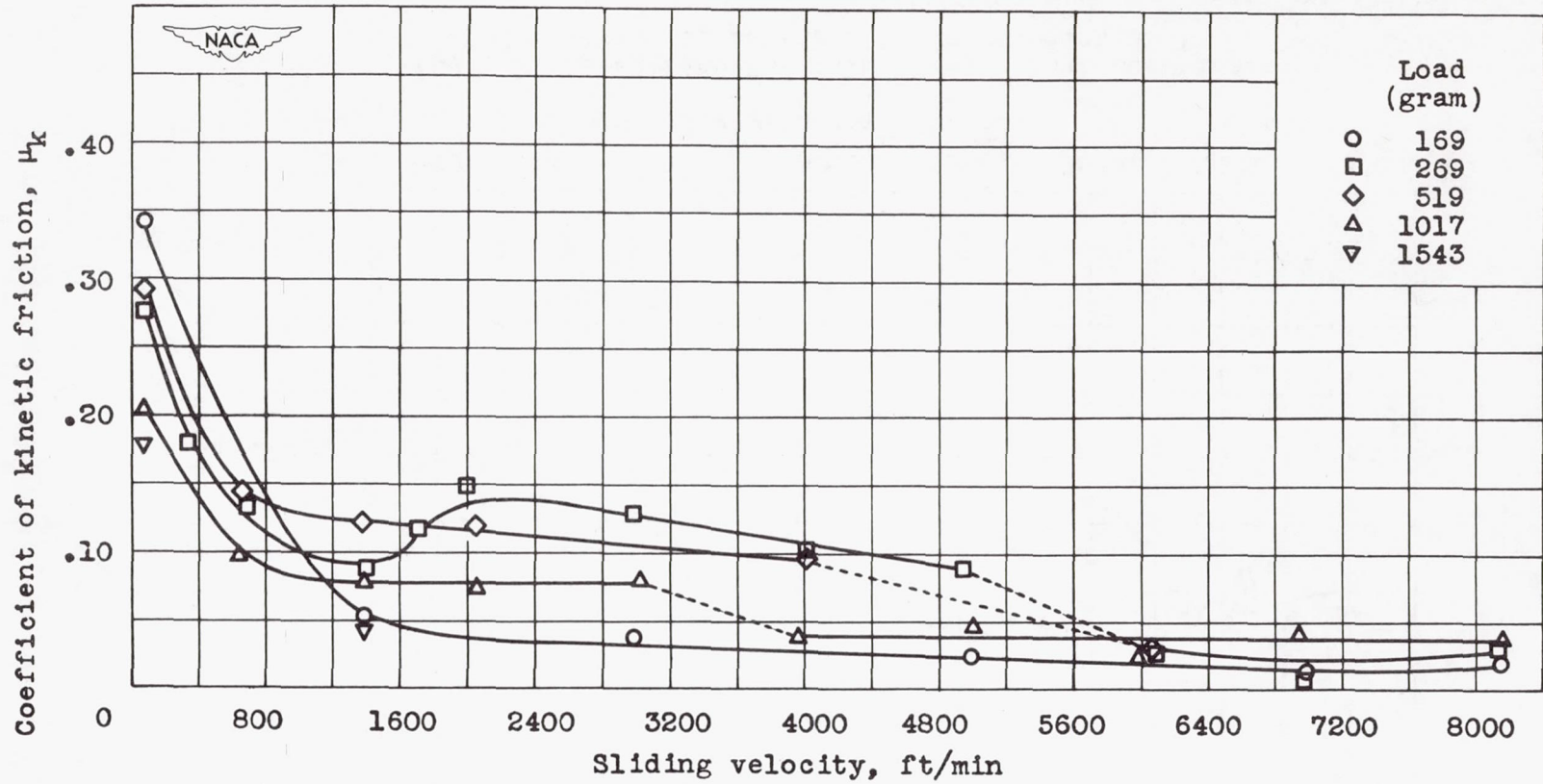

(a) Ferrous-chloride $FeCl_2$ film showing effect of various loads on friction.

Figure 7. - Effect of sliding velocity on friction for surfaces with solid films of compounds of type produced by extreme-pressure lubricant additives.

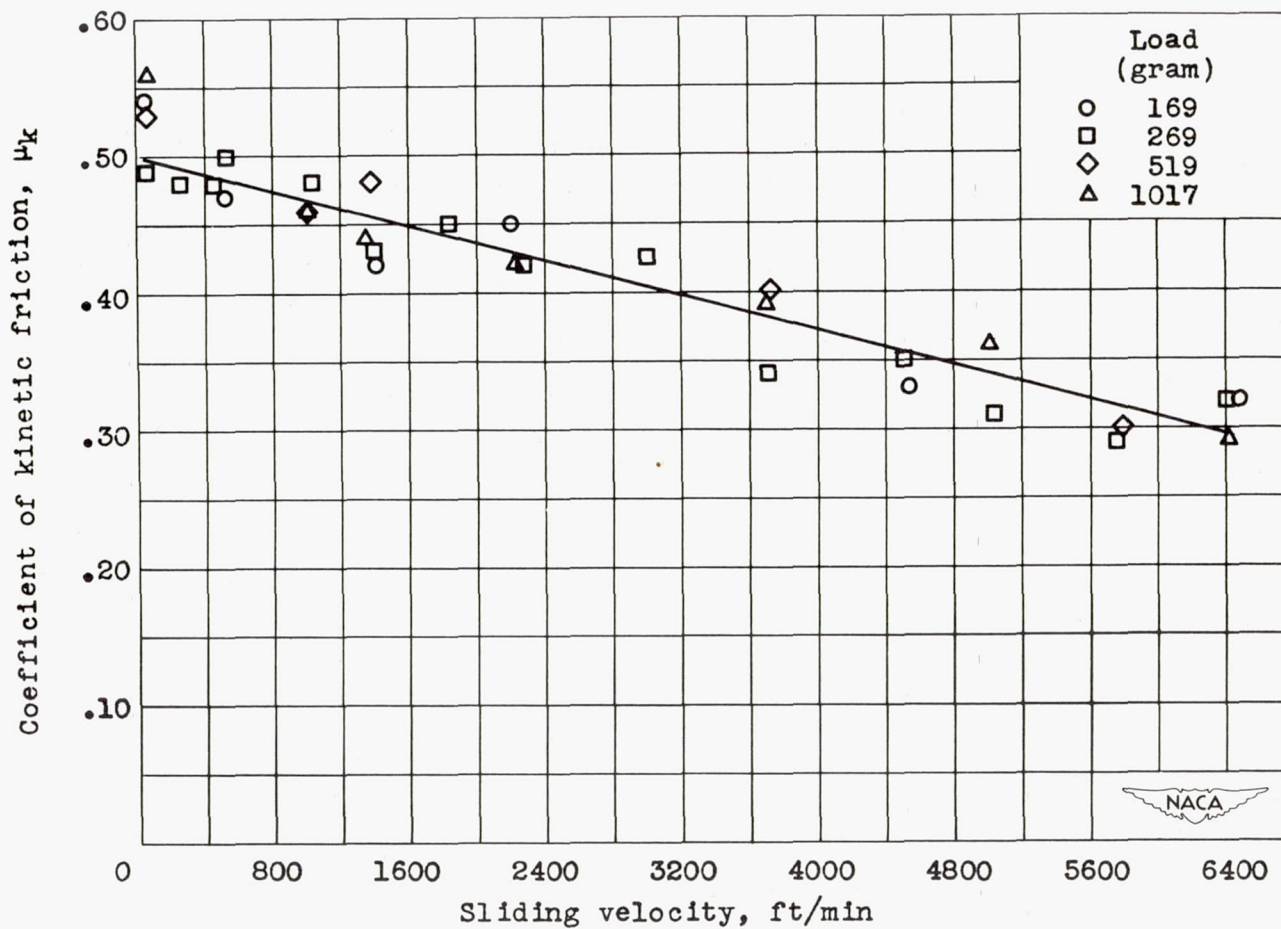

(b) Ferrous-sulfide FeS film showing that coefficient of friction is essentially independent of load.

Figure 7. - Continued. Effect of sliding velocity on friction for surfaces with solid films of compounds of type produced by extreme-pressure lubricant additives.

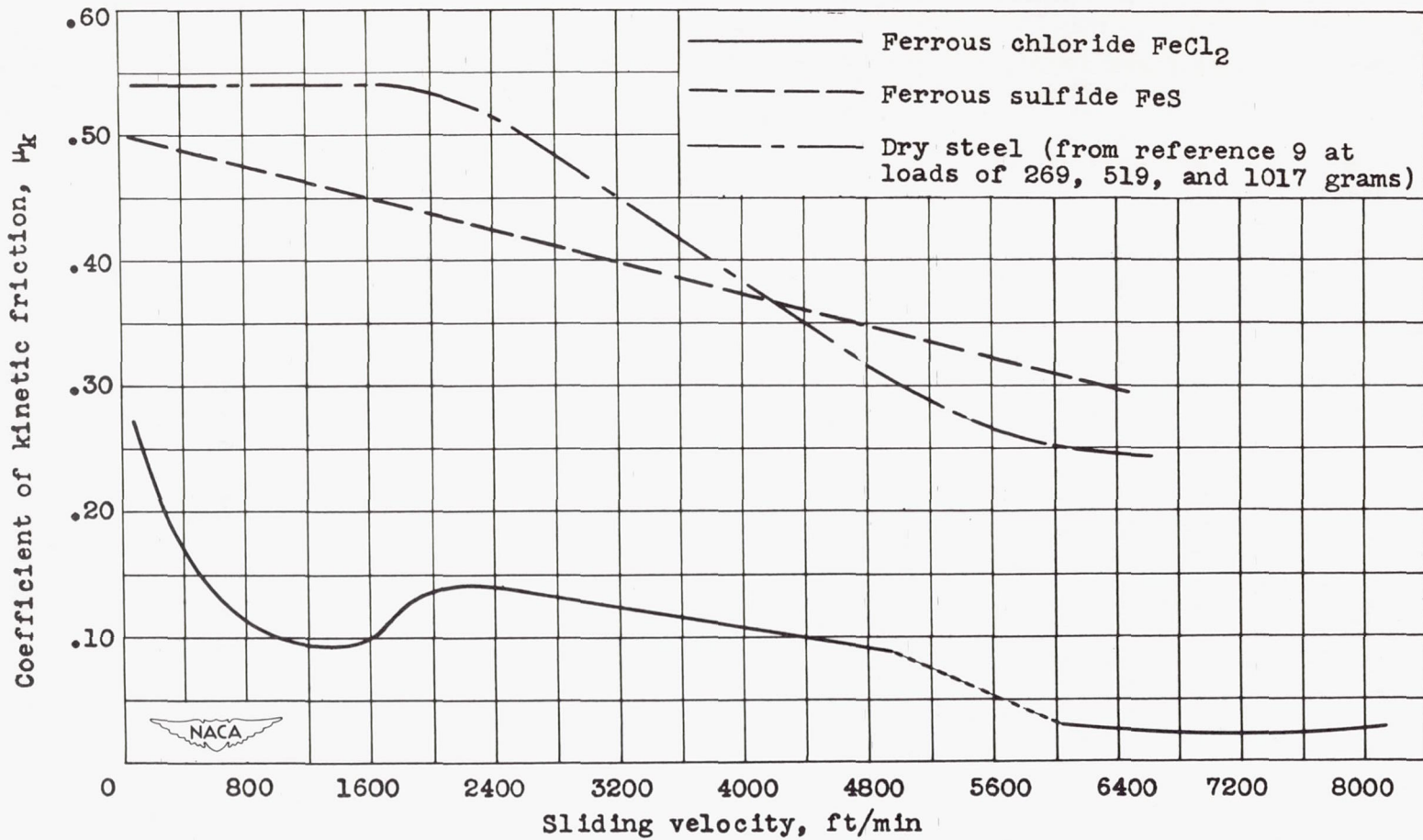

(c) Ferrous-chloride FeCl_2 and ferrous-sulfide FeS films with loads of 269 grams.

Figure 7. - Concluded. Effect of sliding velocity on friction for surfaces with solid films of compounds of type produced by extreme-pressure lubricant additives.

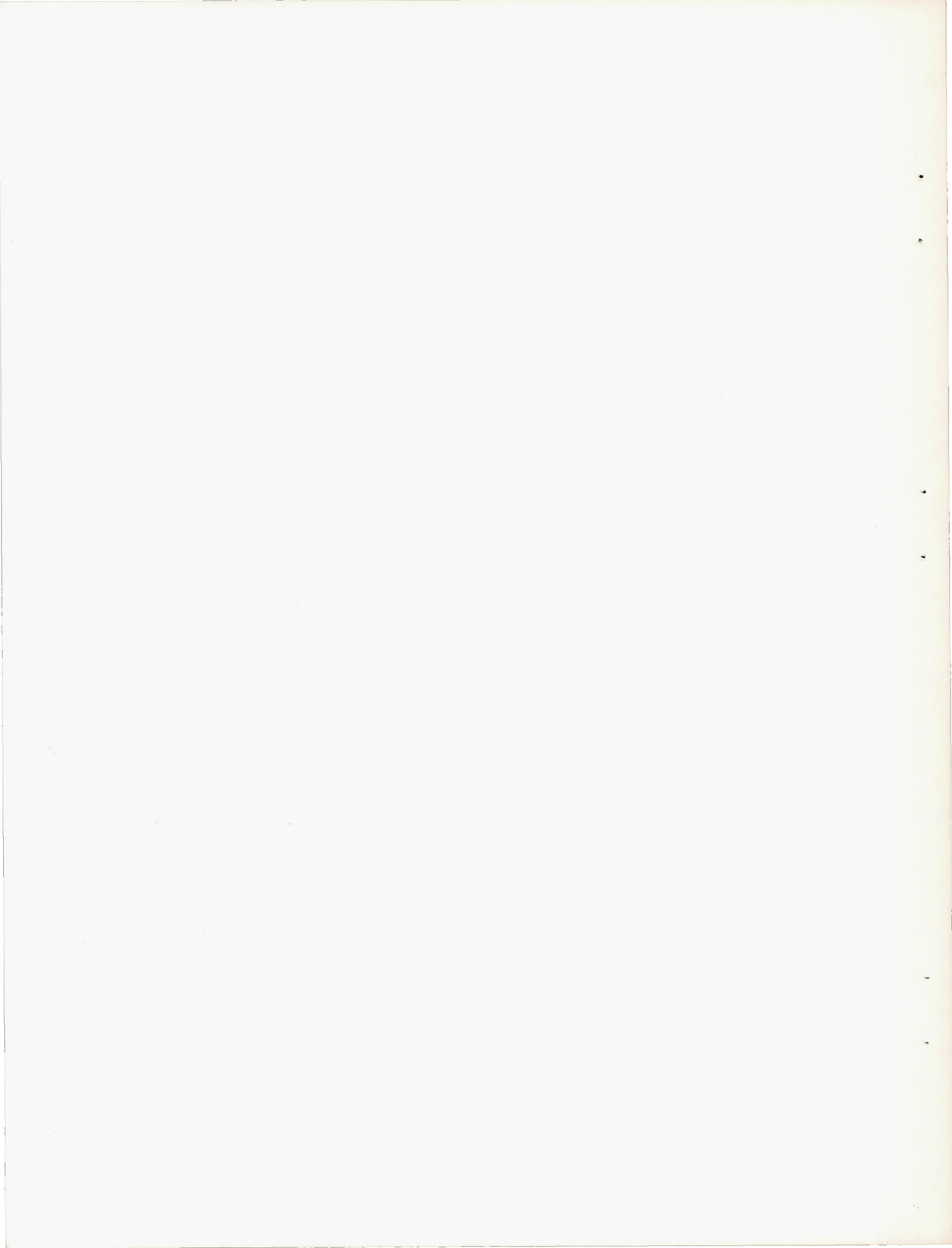

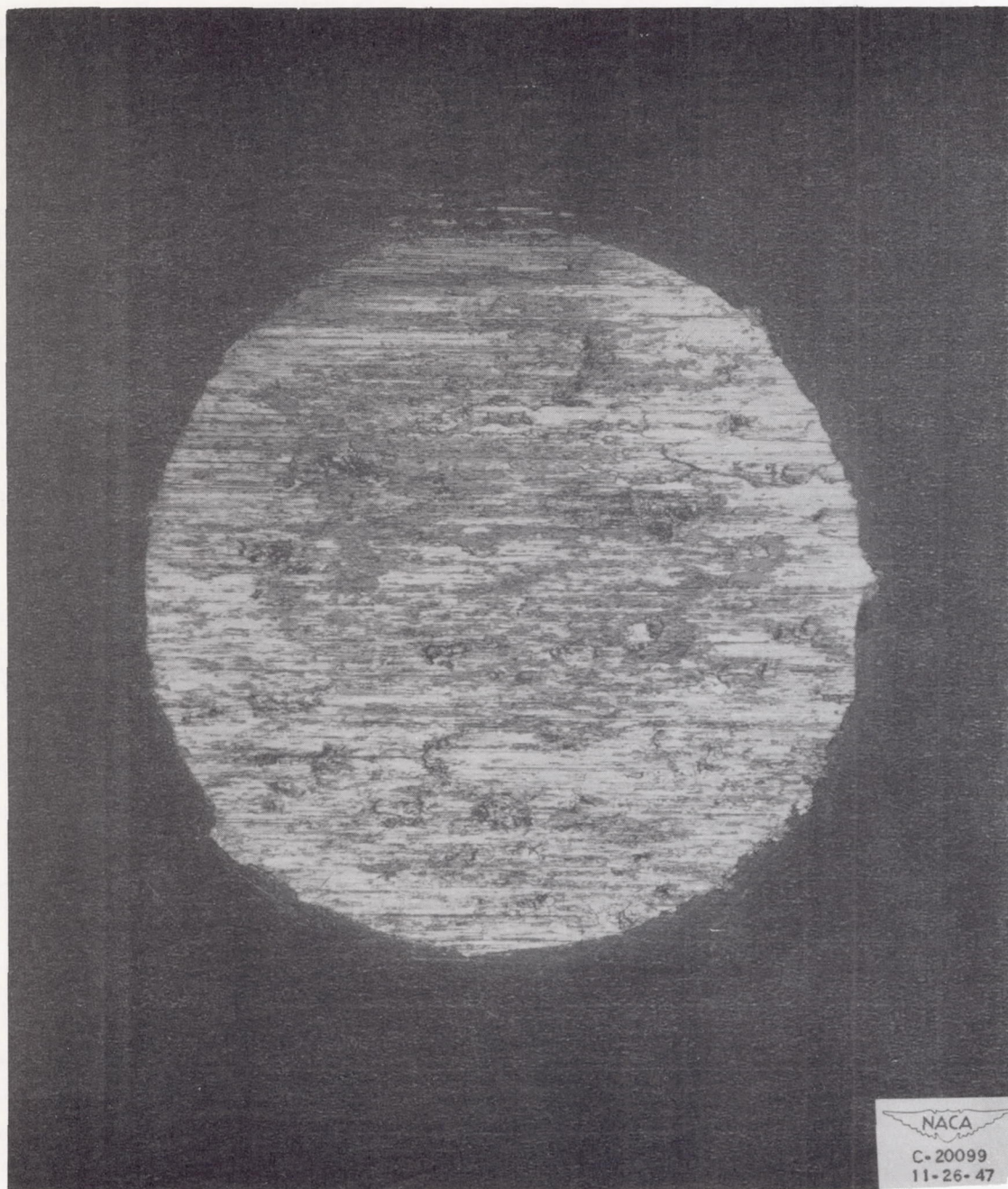
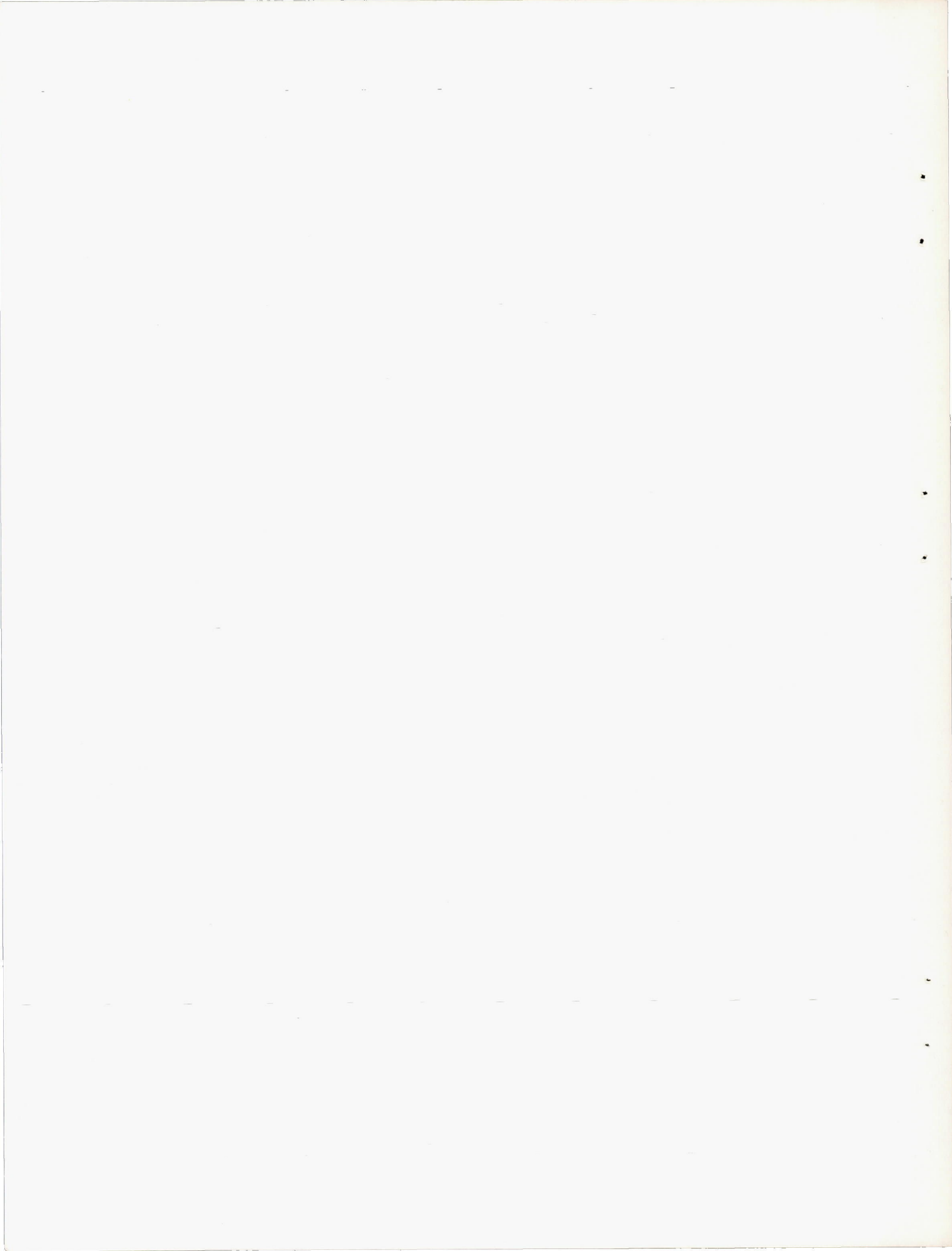
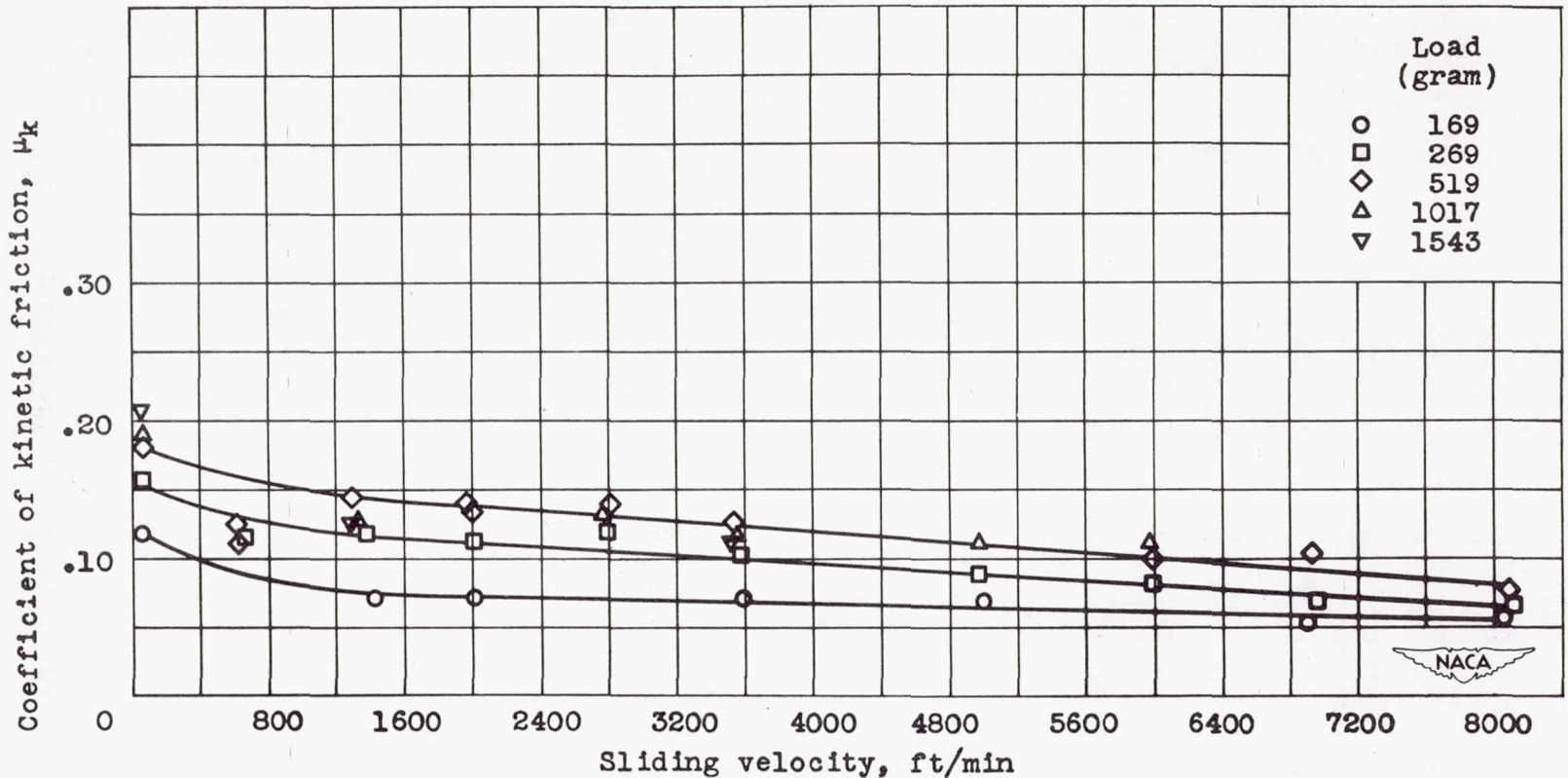

Figure 8. - Photomicrograph of wear spot on spherical rider after operation for 6 seconds at 2000 feet per minute with 269 grams load on SAE 1020 steel disk having solid film of ferrous sulfide FeS . Kinetic friction, 0.44; wear-spot diameter, 0.043 inch. $\times 100$.





(a) Molybdenum-disulfide MoS_2 film showing effect of various loads on friction. At high loads (519 and 1017 grams) essentially no effect of load on friction was observed.

Figure 9. - Effect of sliding velocity on friction for surfaces with solid films of molybdenum disulfide MoS_2 and oriented graphite C.

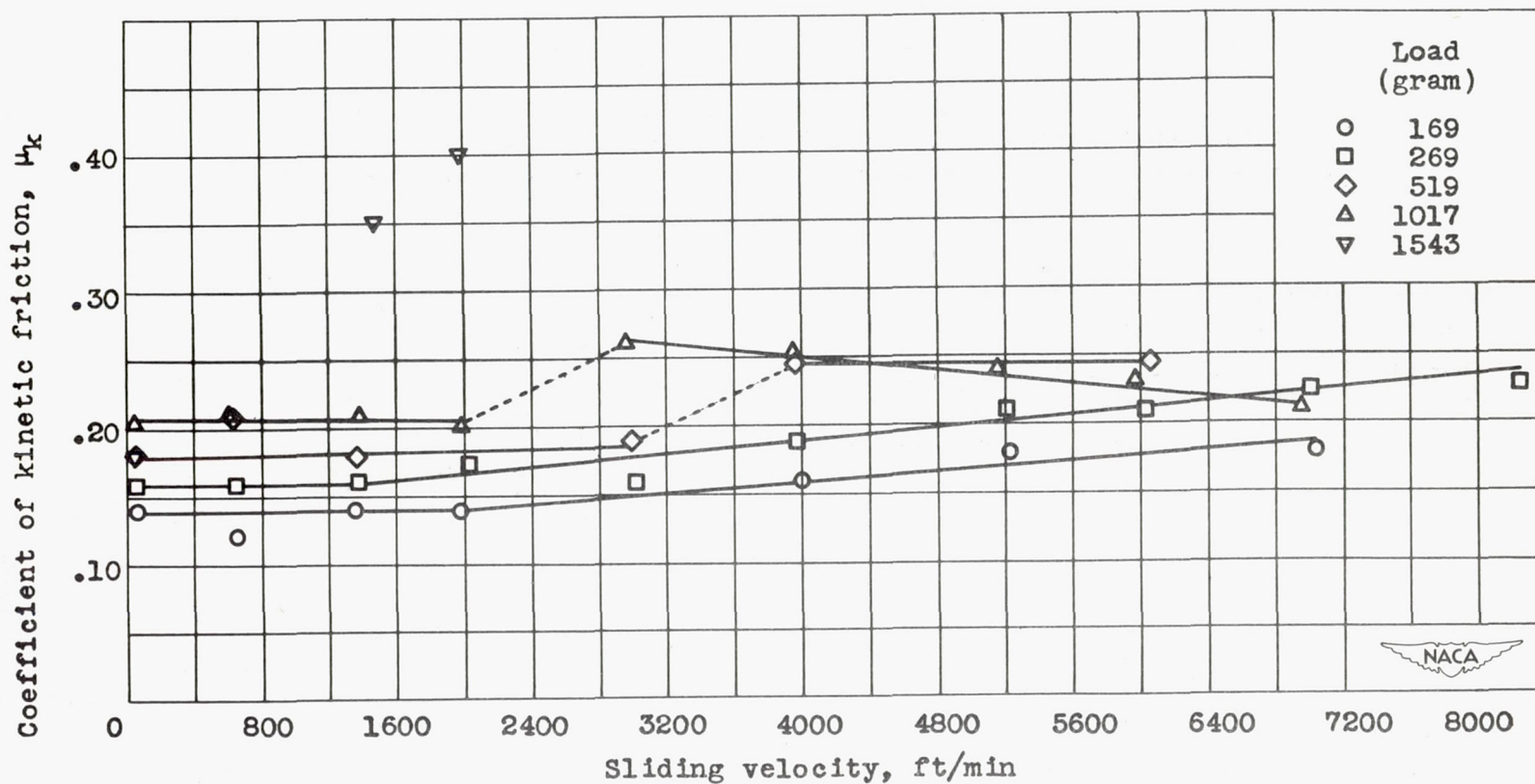

(b) Oriented-graphite C film showing effect of various loads on friction.

Figure 9. - Continued. Effect of sliding velocity on friction for surfaces with solid films of molybdenum disulfide MoS_2 and oriented graphite C.

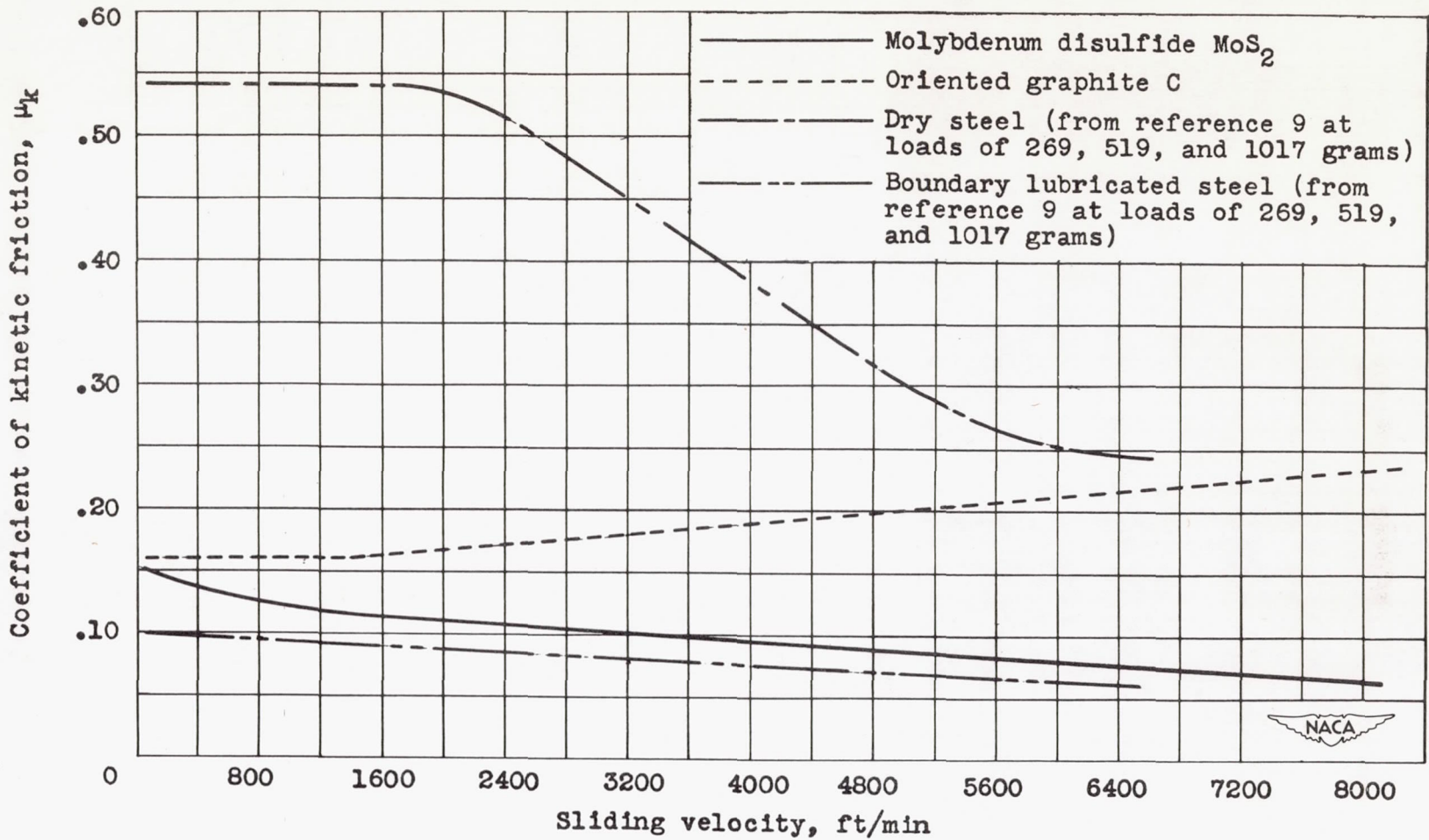

(c) Molybdenum-disulfide MoS_2 and oriented-graphite C films with loads of 269 grams.

Figure 9. - Concluded. Effect of sliding velocity on friction for surfaces with solid films of molybdenum disulfide MoS_2 and oriented graphite C.

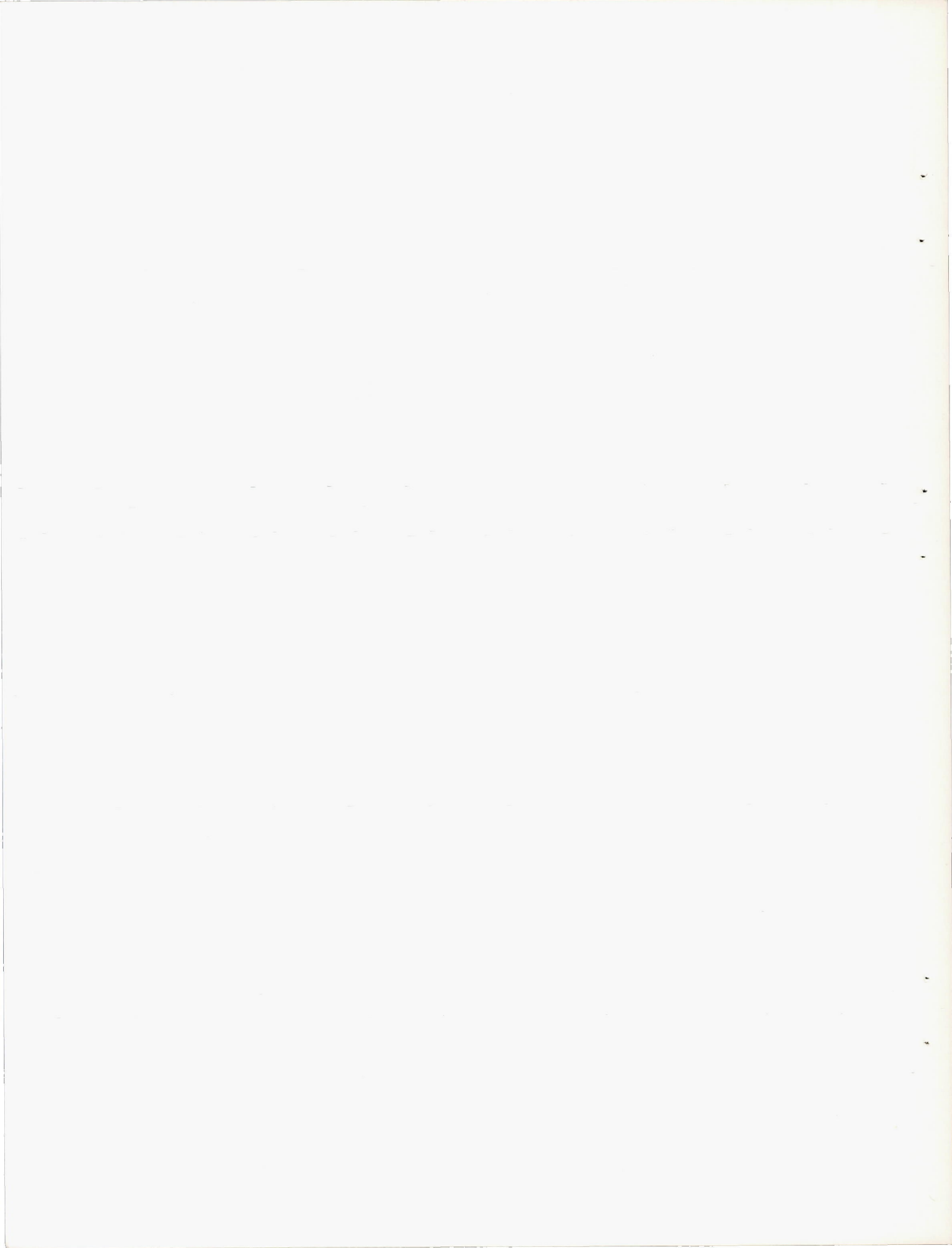

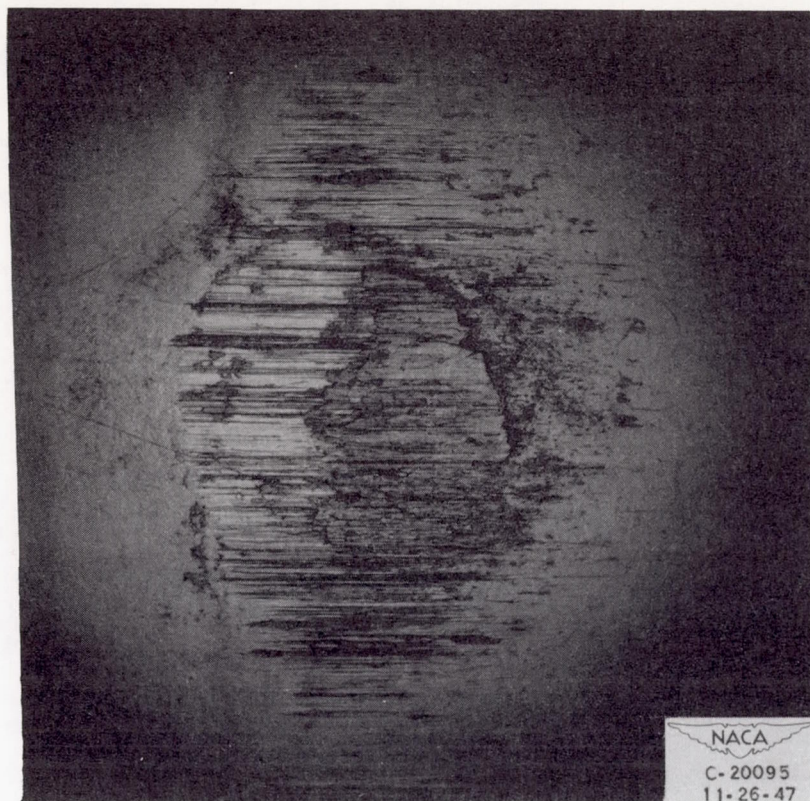

(a) Wear spot on spherical rider;
kinetic friction μ_k , 0.11;
wear-spot diameter, 0.020 inch.
(Mating surface shown in fig. 10(b).)

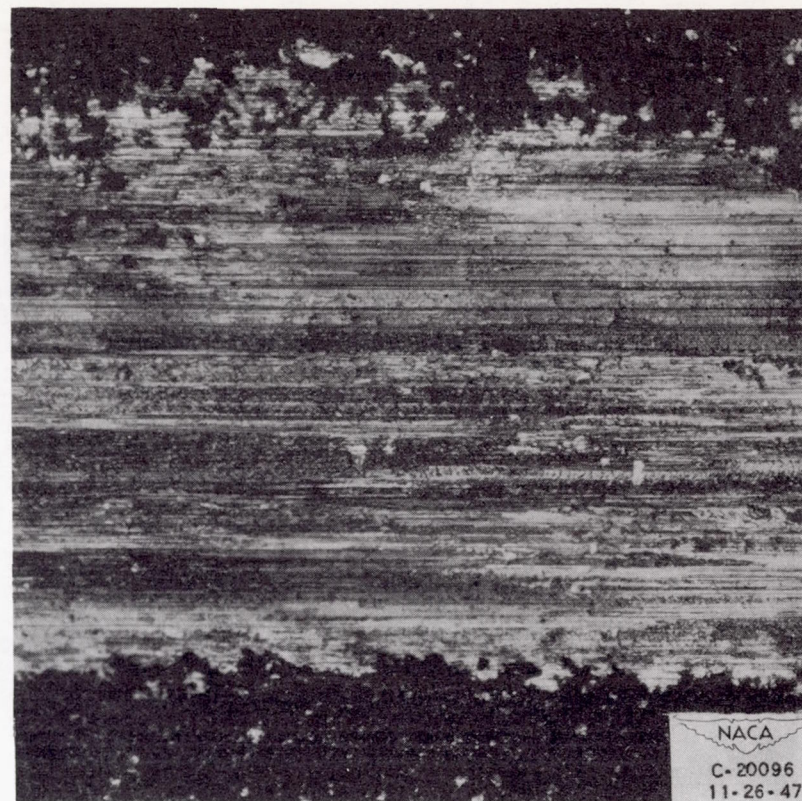

(b) Wear track on disk specimen with
molybdenum-disulfide MoS_2 film.
(Mating surface shown in fig. 10(a).)

Figure 10. - Photomicrographs of wear areas after operation for 6 seconds at 2000 feet per minute with 269 grams load on SAE 1020 steel disks having dry lubricating films. $\times 100$.

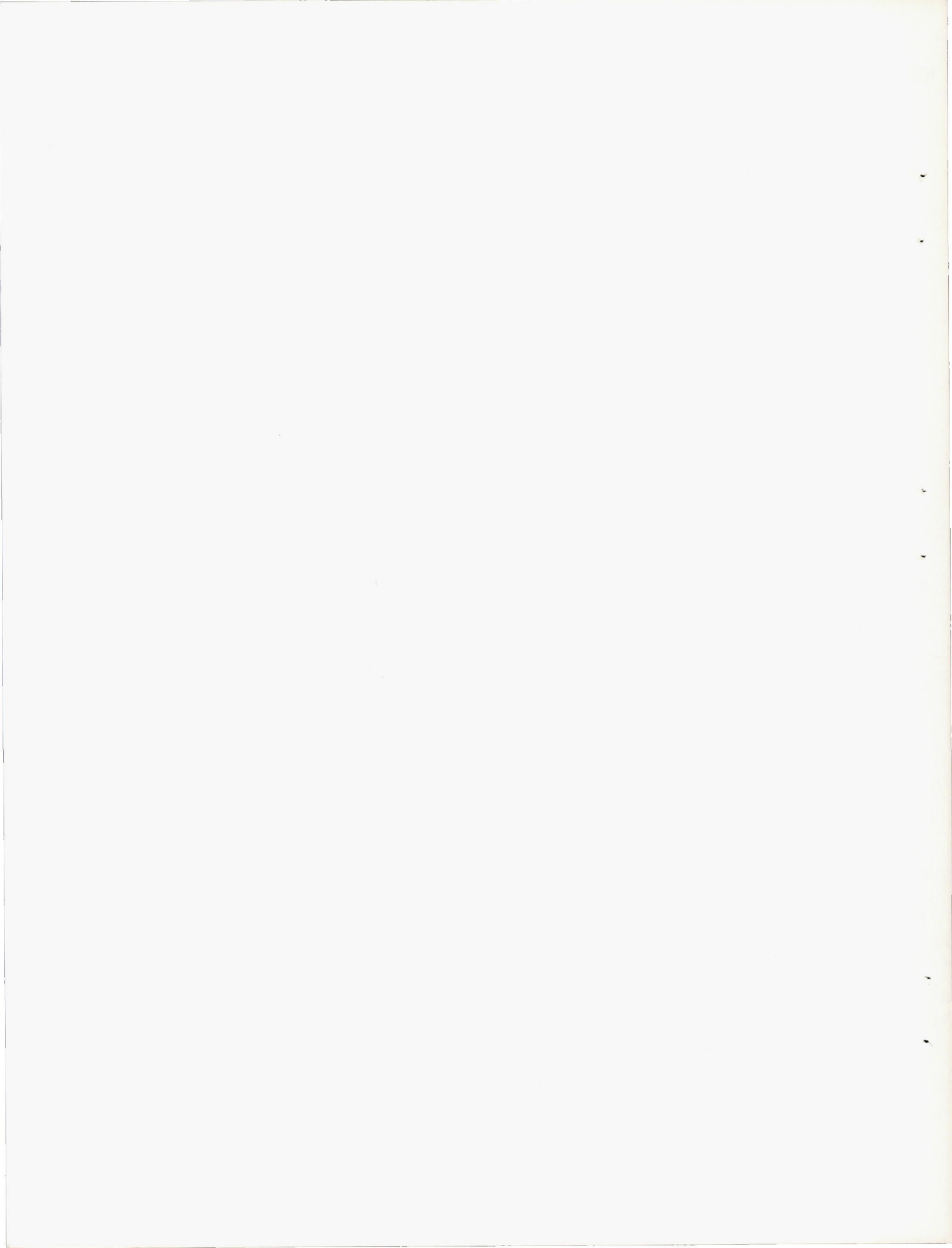

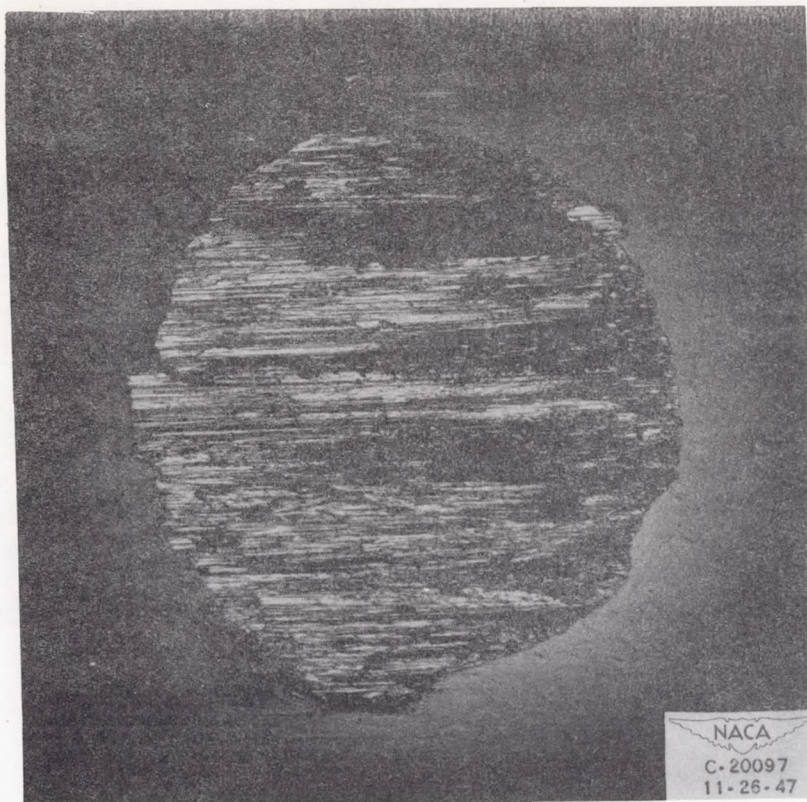

(c) wear spot on spherical rider,
kinetic friction μ_k , 0.17;
wear-spot diameter, 0.031 inch.
(Mating surface shown in fig. 10(d).)

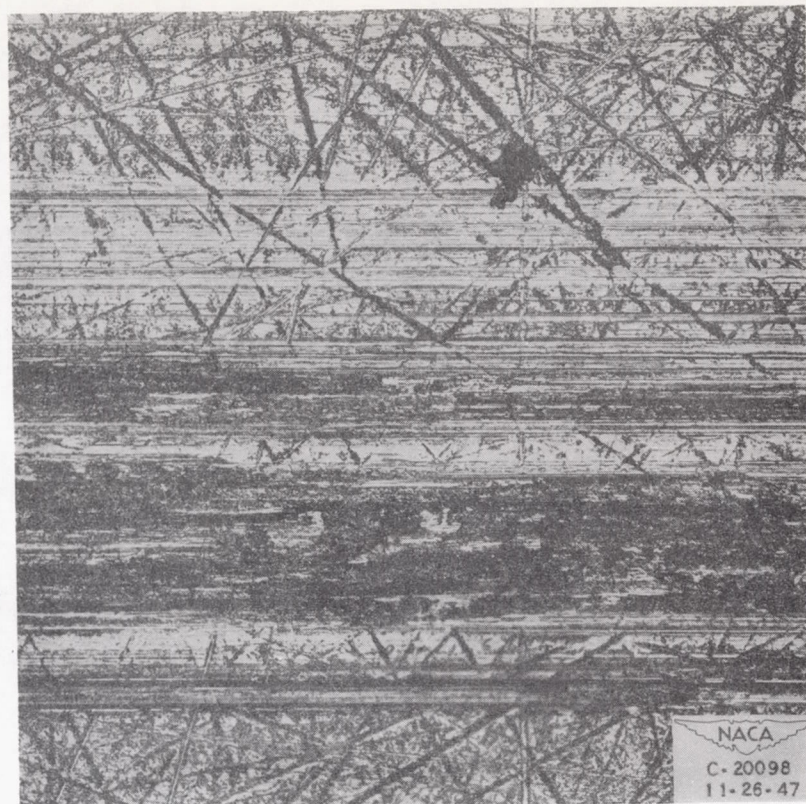

(d) Wear track on disk specimen with
graphite film. (Mating surface
shown in fig. 10(c).)

Figure 10. - Concluded. Photomicrographs of wear areas after operation for 6 seconds at 2000 feet per minute with 269 grams load on SAE 1020 steel disks having dry lubricating films. x100.

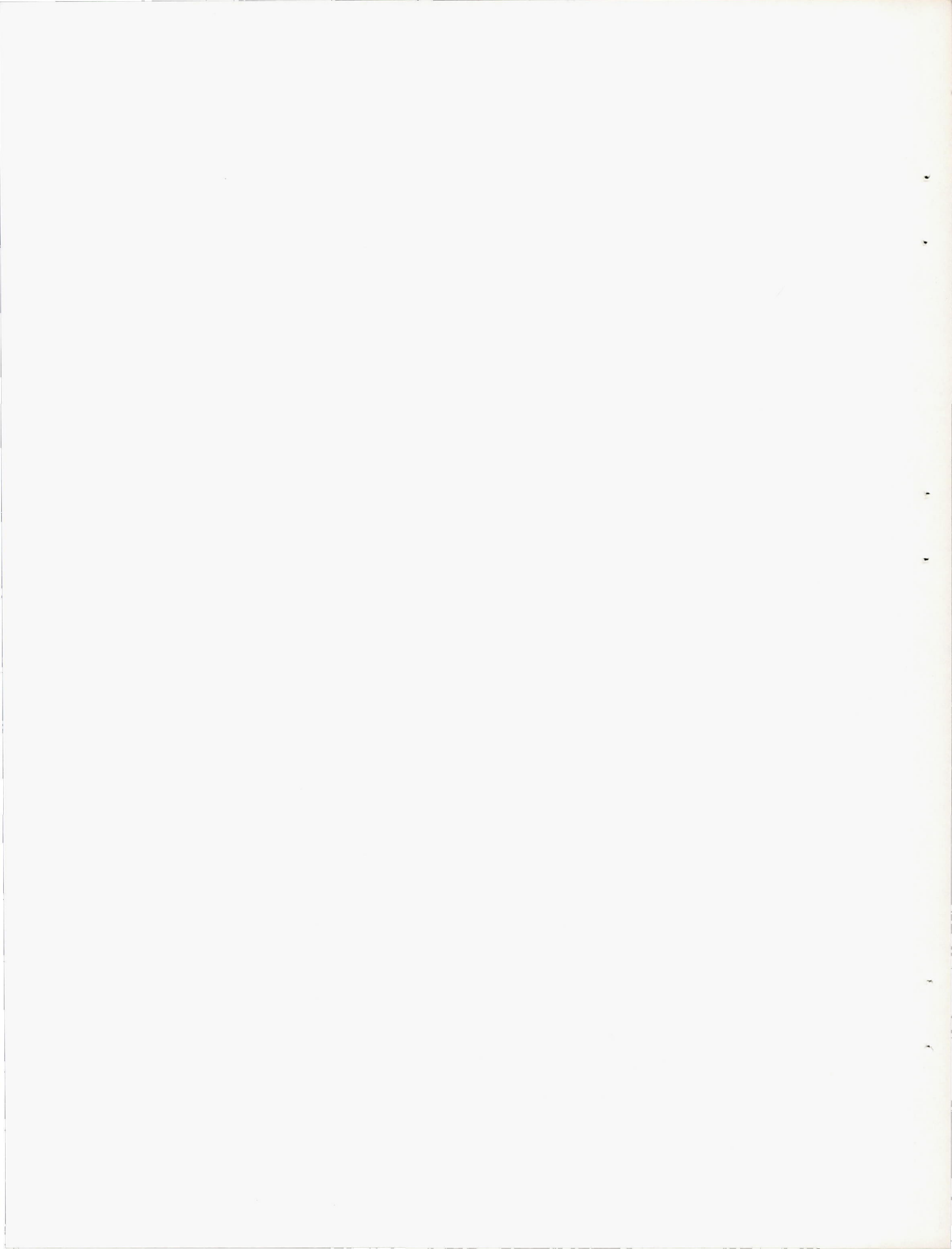

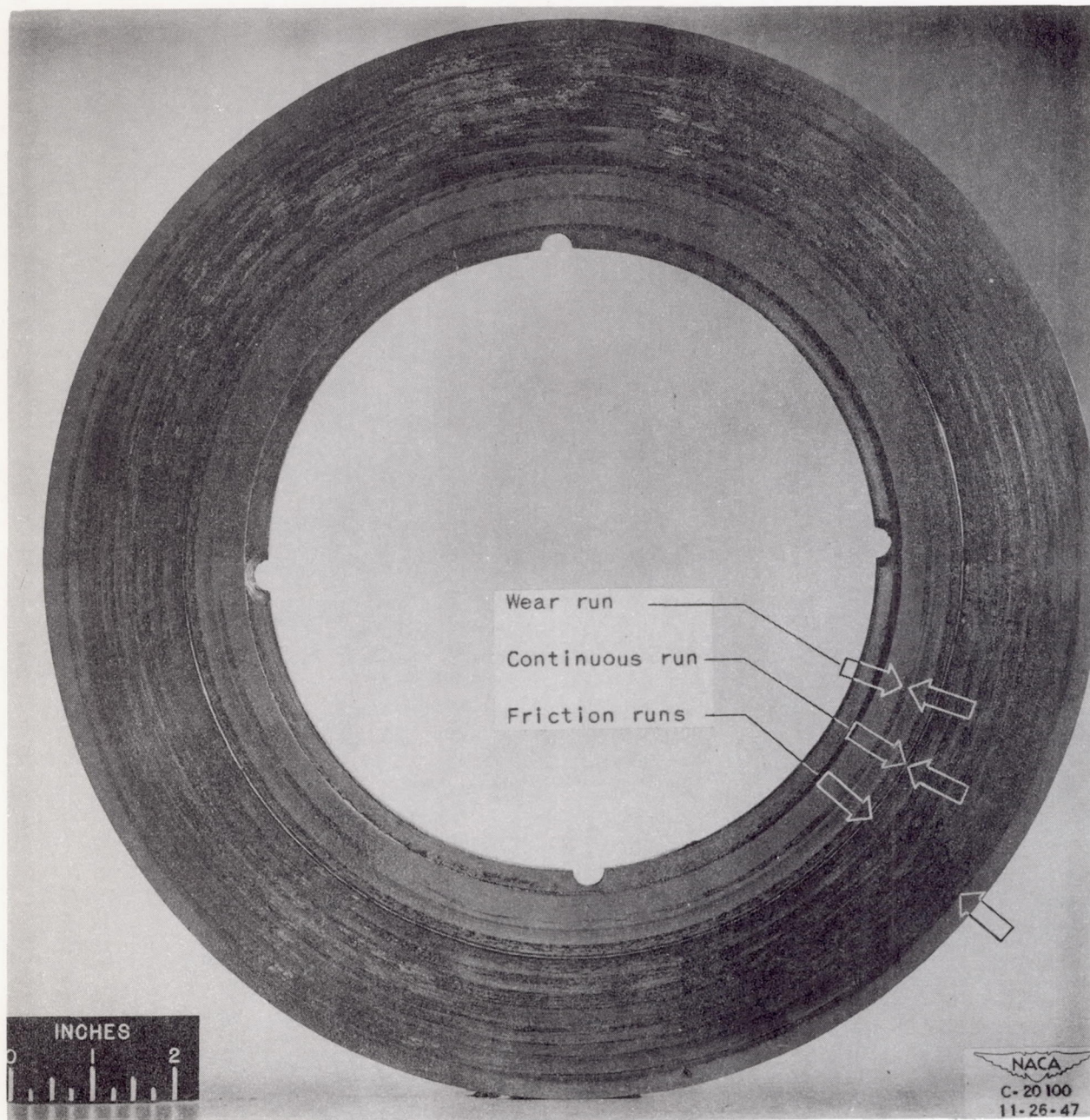

(a) Entire disk showing areas of test runs to determine wear (innermost circumferential trace) and friction (between innermost and outermost circumferential traces).

Figure 11. - Photographs of steel disk covered with molybdenum-disulfide MoS_2 film after friction and wear experiments.

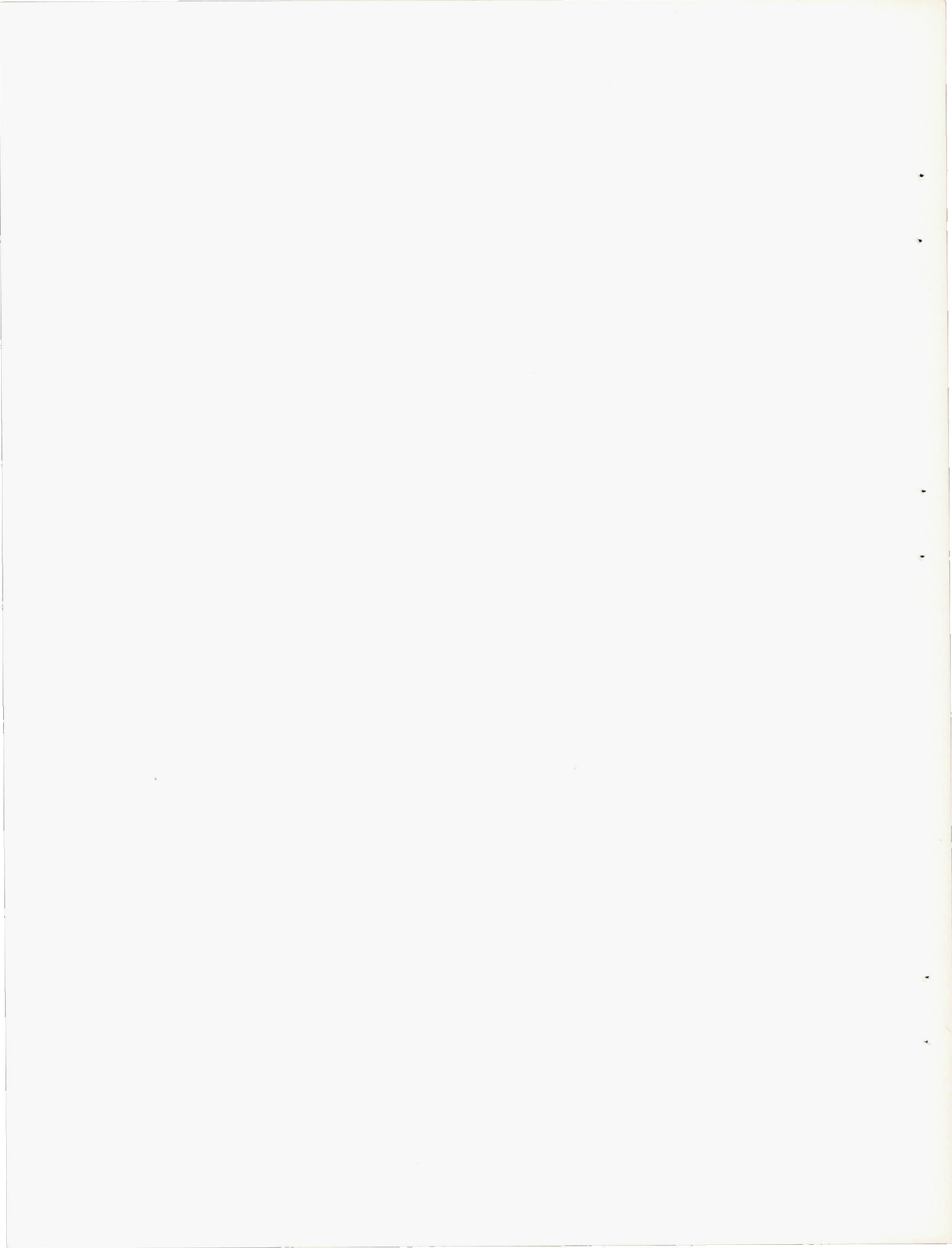

866

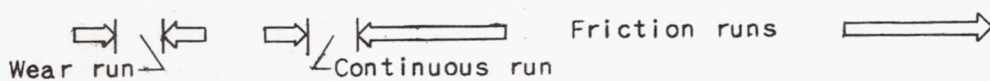
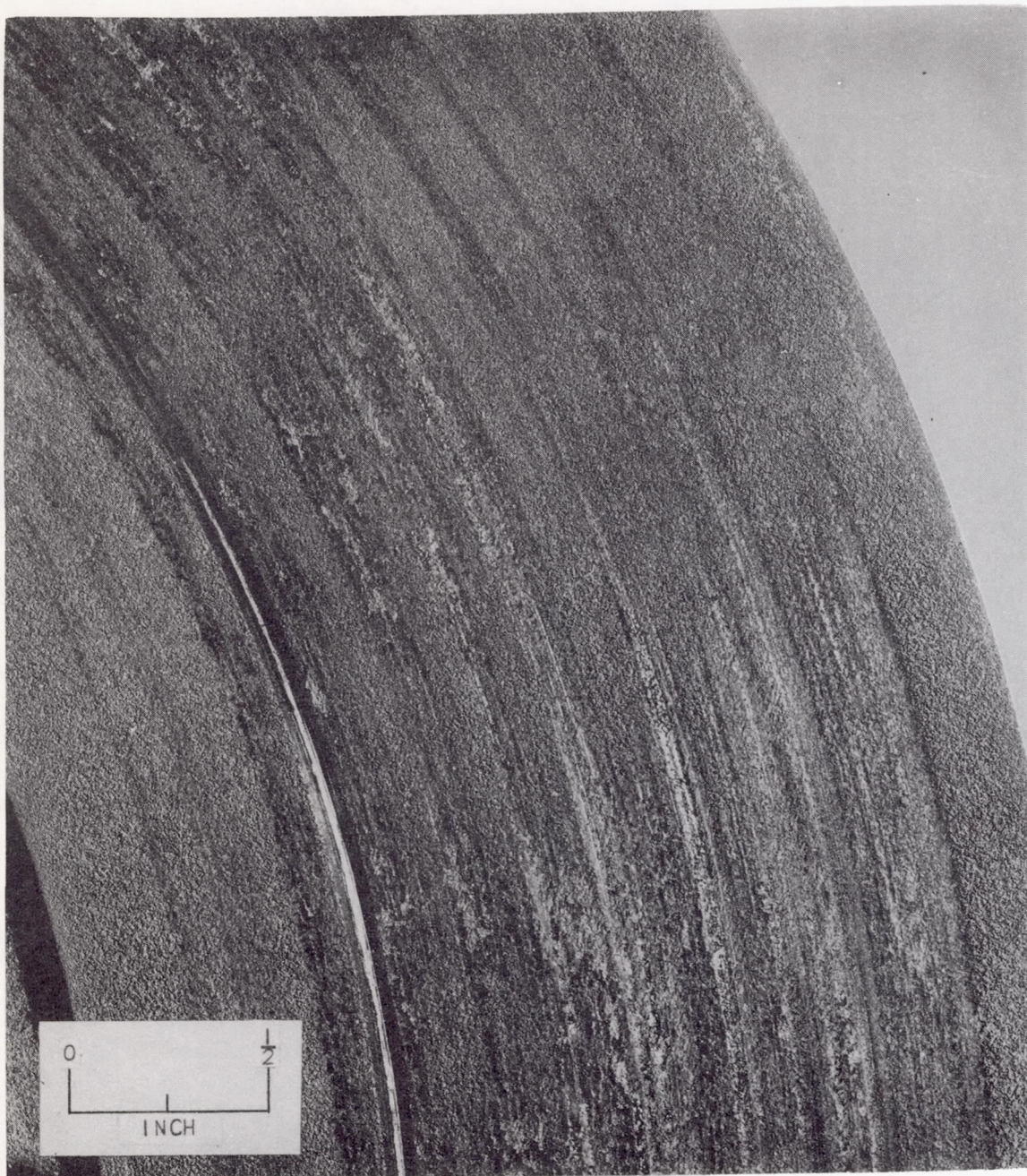

(b) Close-up of wear and friction runs showing that, for continuous friction run, the rider has penetrated to steel base in some locations.
x2.3

NACA
C-20101
11-26-47

Figure 11. - Continued. Photographs of steel disk covered with molybdenum-disulfide MoS_2 film after friction and wear experiments.

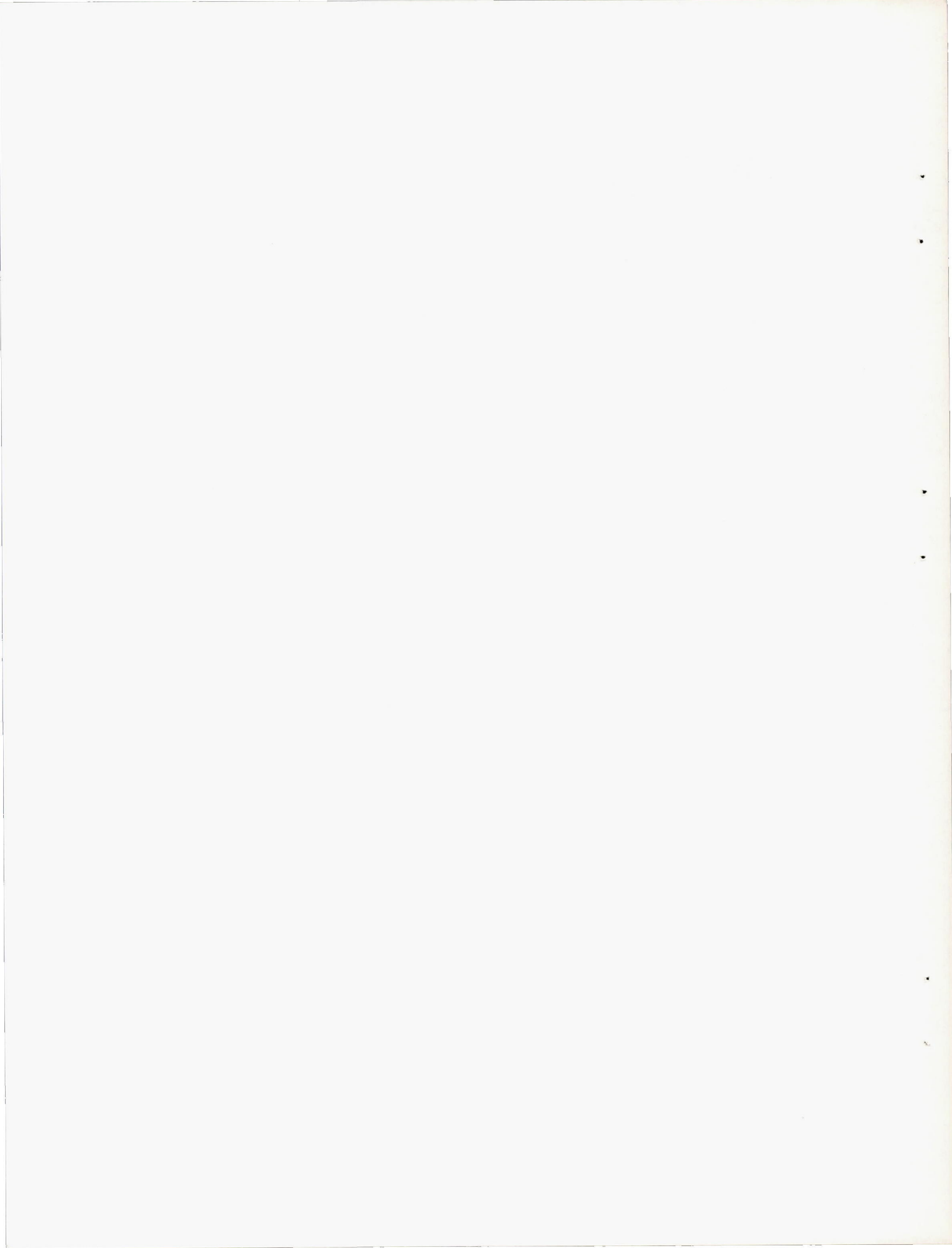

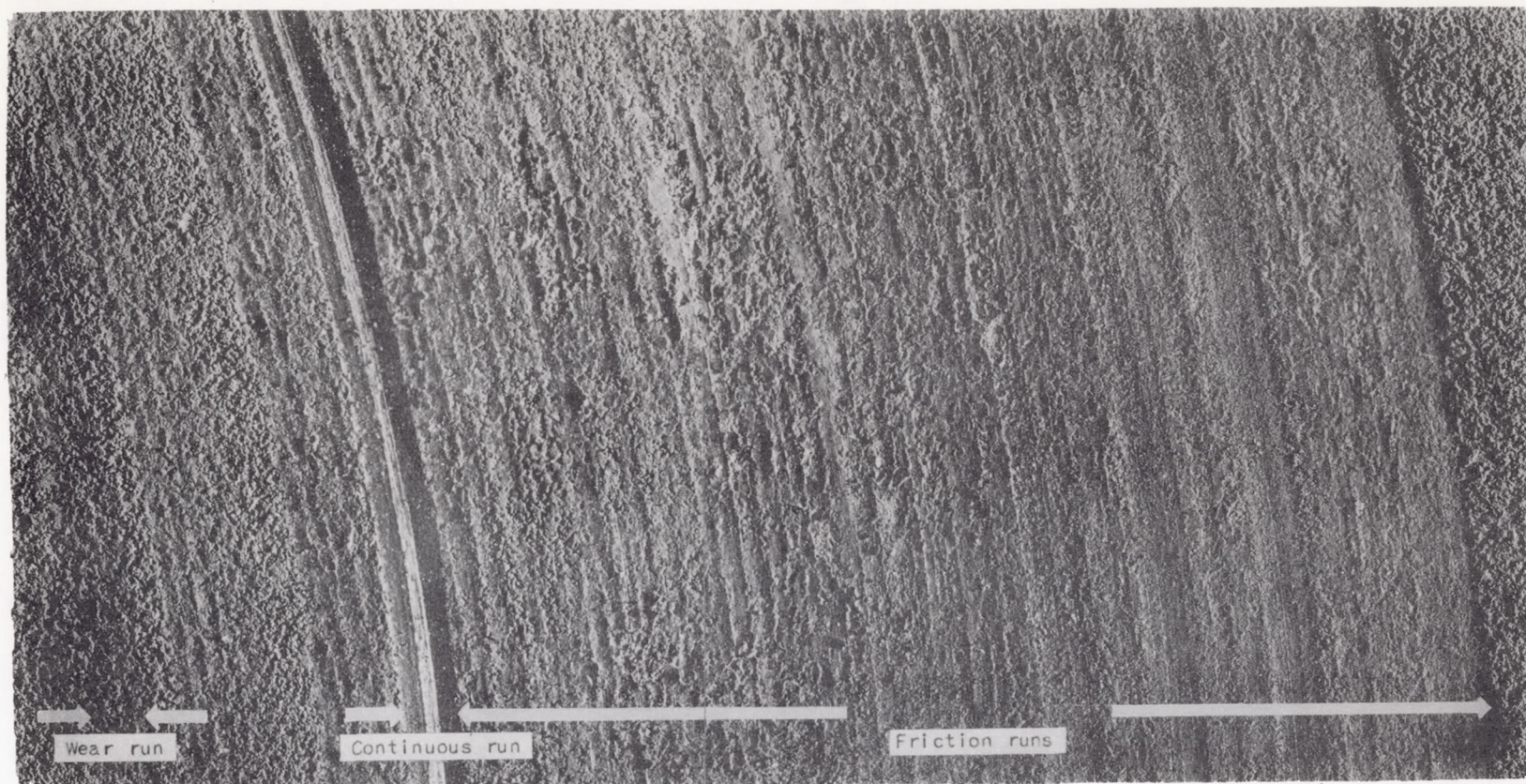

NACA
C-20103
11-26-47

0 1/4
INCH

NACA
C-20102
11-26-47

(c) Close-up of continuous and friction runs showing that, for friction runs, the rider has not penetrated film material at any location despite high initial surface stresses of 108,000 to 225,000 pounds per square inch. x4.3

Figure 11. - Concluded. Photographs of steel disk covered with molybdenum-disulfide MoS₂ film after friction and wear experiments.