

NACA TN 2183 8098

TECH LIBRARY KAFB, NM
0065139

NATIONAL ADVISORY COMMITTEE FOR AERONAUTICS

TECHNICAL NOTE 2183

ANALYSIS FOR CONTROL APPLICATION OF DYNAMIC
CHARACTERISTICS OF TURBOJET ENGINE
WITH TAIL-PIPE BURNING

By Melvin S. Feder and Richard Hood
Lewis Flight Propulsion Laboratory
Cleveland, Ohio



Washington
September 1950

AFRONT
TECHNICAL LIBRARY
SEP 20 1951

317.98/41



NATIONAL ADVISORY COMMITTEE FOR AERONAUTICS

TECHNICAL NOTE 2183

ANALYSIS FOR CONTROL APPLICATION OF DYNAMIC

CHARACTERISTICS OF TURBOJET ENGINE

WITH TAIL-PIPE BURNING

By Melvin S. Feder and Richard Hood

SUMMARY

The general form of transfer functions for a turbojet engine with tail-pipe burning was developed and the relations among the variables in these functions were found from the transfer functions and from engine thermodynamics. By means of these relations, the dynamic characteristics of the engine can be found from steady-state data and one transient relation.

The results of this analysis showed that if a step change in engine fuel flow causes the initial value of turbine-outlet temperature to be greater than the final value, a step change in exhaust-nozzle area or tail-pipe-burner fuel flow will cause the initial value of turbine-outlet temperature to be less than the final value, and conversely. Schedules that maintain constant engine speed and turbine-outlet temperature for a range of tail-pipe conditions and constant engine speed for a range of exhaust-nozzle areas were explicitly defined in terms of steady-state data.

The results, when applied to the design of a noninteracting control system, gave the form of all the required control functions and showed that all but one of the control functions can be determined from steady-state engine data.

INTRODUCTION

The application of tail-pipe burning to turbojet engines has become increasingly important in improving the performance and the effectiveness of this type of aircraft power plant. The addition of the tail-pipe burner to the turbojet engine, however, increases the complexity of the control problem because of the additional degrees of freedom possessed by the engine and because both engine speed and temperature must be accurately controlled to obtain

maximum engine performance with safe engine operation. Furthermore, the action of one control variable during the transient state causes changes in the other variables.

The first basic problem that must be solved before control synthesis can proceed is that of determining the dynamic characteristics of the engine. Accordingly, an analysis of the dynamic behavior of the turbojet engine with tail-pipe burning was made at the NACA Lewis laboratory and is presented herein.

In references 1 and 2, it is shown that the dominant dynamic characteristics of turbojet and turbine-propeller engines, respectively, may be expressed in terms of the slopes of engine-speed torque curves, which are derivable from engine performance data. It follows, as shown in references 1 and 2, that the engine processes can be considered quasi-static, which implies that a thermodynamic process during transient conditions follows the path of equilibrium-state points. Thermodynamic relations that are valid for steady-state engine operation can therefore be extended to the transient state. Thermodynamic relations based on this result are used in reference 3 to determine the effect of the primary engine variables on the dynamic behavior of a turbojet engine with a centrifugal-flow compressor.

In the present investigation of the dynamic behavior of a turbojet engine with tail-pipe burning, the general form of the engine transfer functions are developed and relations among the coefficients and the time constants are derived from the transfer functions and from thermodynamic relations for the engine. The engine is considered a linear system in which incremental changes from steady-state operating conditions are considered.

The relations among the coefficients and the time constants are used to determine the indicial response characteristics of the engine and the analysis is then applied to scheduled and noninteraction controls.

ANALYSIS

General Form of Engine Dynamics

The development and the data presented in reference 1 for a turbojet engine and in reference 2 for a turbine-propeller engine show that, at close-to-equilibrium operating conditions, unbalanced torque can be expressed as a function of the engine speed and the

engine independent variables. For a turbojet engine with tail-pipe burning operating at a constant ram pressure ratio and altitude, it therefore follows that unbalanced torque can be expressed as a function of the engine speed and the engine independent variables in the following manner: (All symbols used in this report are defined in appendix A.)

$$Q = \mathcal{F}(N, F_e, A, F_t) \quad (1)$$

also

$$Q = I D(\Delta N) \quad (2)$$

Equation (1), when expanded and linearized around steady-state operating points and combined with equation (2), leads to the transfer function for the response of engine speed to changes in the independent variables. This expression, which is developed in appendix B, is

$$\frac{\Delta N}{N} = \frac{a_1}{\tau_{D+1}} \frac{\Delta F_e}{F_e} + \frac{a_2}{\tau_{D+1}} \frac{\Delta A}{A} + \frac{a_3}{\tau_{D+1}} \frac{\Delta F_t}{F_t} \quad (3)$$

As shown in appendix B, the response of turbine-outlet temperature to changes in the independent variables is given by

$$\frac{\Delta T_2}{T_2} = \frac{\tau_{1D+1}}{\tau_{D+1}} b_1 \frac{\Delta F_e}{F_e} + \frac{\tau_{2D+1}}{\tau_{D+1}} b_2 \frac{\Delta A}{A} + \frac{\tau_{3D+1}}{\tau_{D+1}} b_3 \frac{\Delta F_t}{F_t} \quad (4)$$

The symbol Δ indicates incremental deviations from steady-state values. The variables F_e , A , and F_t , which appear in the denominators, are the steady-state values. Thus, the term $\Delta N/N$, for example, is the relative or percentage change in engine speed. The variables have been placed in this dimensionless form to make them consistent with the thermodynamic development to follow.

From equilibrium conditions ($D \rightarrow 0$) and the principle of superposition, the coefficients a_1 through b_3 are shown in appendix B to be proportional to the slopes of steady-state engine operating curves. These coefficients are defined in the following table:

Coefficient	Definition of coefficient	Variables constant
a_1	$\frac{\Delta N}{N} / \frac{\Delta F_e}{F_e}$	A, F_t
a_2	$\frac{\Delta N}{N} / \frac{\Delta A}{A}$	F_e , F_t
a_3	$\frac{\Delta N}{N} / \frac{\Delta F_t}{F_t}$	F_e , A
b_1	$\frac{\Delta T_2}{T_2} / \frac{\Delta F_e}{F_e}$	A, F_t
b_2	$\frac{\Delta T_2}{T_2} / \frac{\Delta A}{A}$	F_e , F_t
b_3	$\frac{\Delta T_2}{T_2} / \frac{\Delta F_t}{F_t}$	F_e , A

The engine time constant τ in equations (3) and (4) is a characteristic time in the transient solution of the homogeneous equations and can therefore be considered as the engine time constant when the engine is displaced from equilibrium and then released (with all the independent variables fixed). The significance of the time constants τ_1 , τ_2 , and τ_3 may be illustrated by dividing equation (3) by equation (4) after the response of N and T_2 to the same forcing function is considered. For example, the response of N to T_2 at constant A and F_t is

$$\frac{\Delta N}{N} = \frac{1}{\tau_1 D + 1} \frac{a_1}{b_1} \frac{\Delta T_2}{T_2} \quad (5)$$

Thus, τ_1 is the engine time constant at constant T_2 , A , and F_t . The engine time constants τ_2 and τ_3 may be defined in a similar manner. The definitions of the engine time constants are presented in the following table:

1364

Engine time constant	Variables constant
τ	F_e, A, F_t
τ_1	T_2, A, F_t
τ_2	T_2, F_e, F_t
τ_3	T_2, F_e, A

Equations (3) and (4) present the general form of engine dynamics for a turbojet engine with tail-pipe burning, because, as shown in appendix B in the discussion of equation (B13), equation (4) will be of the same form for any dependent variable. It also follows that the form of equations (3) and (4) is general for other engines in addition to turbojet engines with tail-pipe burning. For example, for the turbine-propeller engine, blade angle can be substituted for A in equations (3) and (4) and F_t vanishes. The time constants and the coefficients can then be defined in the manner previously described.

A relation among the coefficients and the time constants in equations (3) and (4) is developed in appendix B. This relation is

$$\frac{b_1}{a_1} (\tau_1 - \tau) = \frac{b_2}{a_2} (\tau_2 - \tau) = \frac{b_3}{a_3} (\tau_3 - \tau) \tag{6}$$

Because of the general form of equations (3) and (4), the relations in equation (6) hold for other engine types beside an engine with tail-pipe burning, and can be used by properly defining the time constants and the coefficients.

Equations (3), (4), and (6) are developed without considering engine thermodynamics. In the analysis that follows, engine thermodynamics will be used to develop relations among the time constants and the coefficients in equations (3) and (4), in addition to the relation presented in equation (6).

Engine Thermodynamics

If the engine processes are considered quasi-static, thermodynamic relations that hold in the steady state can be extended to the transient state. Because unbalanced torque is a small difference

between two large members, only those thermodynamic expressions that are precise and independent of engine efficiencies will be used. These expressions are the heat-balance equation and the continuity equation.

Engine and tail-pipe equations. - For a turbojet engine, the heat-balance equation for the engine is

$$H_e = \frac{F_e}{W_a} = \frac{QN}{W_a} + H_2 - H_1 \quad (7)$$

where QN/W_a is the additional factor introduced by consideration of nonequilibrium conditions.

The heat balance for a tail-pipe burner is

$$H_t = \frac{F_t}{W_a} = H_3 - H_2 \quad (8)$$

The symbols H_e and H_t are introduced to make the equations that follow more compact.

From the continuity of flow and the definition of Mach number, it follows that the gas flow through the exhaust nozzle is

$$W_a = \frac{P_3 A M}{\sqrt{t_3}} \sqrt{\frac{\gamma_3 g}{R}} \quad (9)$$

Differentiation and linearization of equations. - If altitude and ram pressure ratio are assumed constant and if specific heat is assumed constant for differential changes in the variables, equations (7) to (9) can be differentiated to give the following expressions:

Equation (7) becomes

$$\frac{dF_e}{F_e} - \frac{dW_a}{W_a} = \frac{N}{F_e} dQ + \frac{H_2}{H_e} \frac{dT_2}{T_2} \quad (10)$$

and equation (8) becomes

$$\frac{dF_t}{F_t} - \frac{dW_a}{W_a} = \frac{H_3}{H_t} \frac{dT_3}{T_3} - \frac{H_2}{H_t} \frac{dT_2}{T_2} \quad (11)$$

If the tail-pipe-burner pressure ratio is assumed constant,

$$\frac{dP_2}{P_2} = \frac{dP_3}{P_3} \quad (12)$$

Differentiation of the continuity equation yields

$$\frac{dW_a}{W_a} = \frac{dA}{A} + \frac{dP_3}{P_3} - \frac{1}{2} \frac{dT_3}{T_3} + \left(\frac{dP_3}{P_3} - \frac{dp_3}{P_3} \right) \left[\frac{1}{\gamma_3} \left(\frac{1}{M^2} - 1 \right) \right] \quad (13)$$

A detailed development of equations (10) and (13) is presented in appendix B.

The term dp_3/p_3 in equation (13) can be omitted because, for constant altitude and subsonic flow in the exhaust nozzle, there is no change in static pressure, and for sonic flow the last term in the equation is zero.

Equations (10) to (13) are in differential form. If it is assumed that the relations among the variables in equations (10) to (13) apply for incremental changes from steady-state conditions, the variables in these equations will be of the same linear form as those in equations (3) and (4). Thus, equation (10) can be considered as

$$\frac{\Delta F_e}{F_e} - \frac{\Delta W_a}{W_a} = \frac{N}{F_e} \Delta Q + \frac{H_2}{H_e} \frac{\Delta T_2}{T_2} \quad (14)$$

In this expression, ΔQ is the difference between the final and the initial unbalanced torque; therefore, because initial conditions are steady state, the initial unbalanced torque is zero and ΔQ is equal to Q . In a similar manner, equations (11) to (13) can be considered in terms of incremental changes in the variables.

Equations (11) to (13) can be combined to eliminate dP_3 and dT_3 . If these manipulations are performed and incremental changes from steady-state conditions are considered, the following equation results:

$$\left(1 - \frac{H_t}{2H_3} \right) \frac{\Delta W_a}{W_a} = (1+m) \frac{\Delta P_2}{P_2} - \frac{\Delta H_2}{H_2} + \left[\frac{\Delta A}{A} - \frac{H_t}{2H_3} \frac{\Delta F_t}{F_t} \right] \quad (15)$$

where

$$m = \frac{1}{\gamma_3} \left(\frac{1}{M^2} - 1 \right)$$

(The last two terms in equation (15) are bracketed because of reference to them in the rest of the report.)

In general, the term $\Delta W_a/W_a$ in equations (14) and (15) is a function of engine speed and compressor-inlet and -outlet conditions. If an axial-flow compressor is assumed, however, the air flow may be approximated as a function of engine speed alone; therefore

$$\frac{\Delta W_a}{W_a} = W_a' \frac{\Delta N}{N} \quad (16)$$

where $W_a' = \frac{dW_a/W_a}{dN/N}$, which is proportional to the slope of the steady-state relation between engine speed and air flow.

In the thermodynamic development, the variables have thus far been placed in the same form as those in the engine transfer function (equations (3) and (4)). In order to obtain engine transfer functions expressed in operational form similar to equations (3) and (4), equations (14) to (16) are combined with one another and with equation (2).

Transfer functions. - Equations (14) to (16) cannot be used to completely describe the engine in terms of the independent variables because ΔP_2 , which appears only in equation (15), cannot be eliminated from these expressions. A complete description of the engine would therefore require an independent expression for P_2 . A physical consideration of the engine shows that P_2 can be expressed as a function of N , F_e , and T_2 . Because this functional relation does not contain A or F_t , and because the variables ΔA and ΔF_t appear only in equation (15) and not in equation (14) or (16), these variables will appear together only in the manner indicated in the bracketed term of equation (15). The engine time constants involving either of these variables are therefore equal, and relations among the coefficients in the transfer functions can be found in the following manner:

For convenience, equation (3) can be rewritten as

$$\frac{\Delta N}{N} = \frac{1}{\tau D+1} a_1 \frac{\Delta F_e}{F_e} + \frac{a_2}{\tau D+1} \left[\frac{\Delta A}{A} + \frac{a_3}{a} \frac{\Delta F_t}{F_t} \right] \quad (17)$$

and from the discussion of equation (15), equation (17) becomes

$$\frac{\Delta N}{N} = \frac{1}{\tau D+1} a_1 \frac{\Delta F_e}{F_e} + \frac{a_2}{\tau D+1} \left[\frac{\Delta A}{A} - \frac{H_t}{2H_3} \frac{\Delta F_t}{F_t} \right] \quad (18)$$

therefore

$$\frac{a_3}{a_2} = - \frac{H_t}{2H_3}$$

Also, as shown in appendix B, the transfer function for the response of N to F_e and T_2 can be found by combining equation (14) with equations (2) and (16) to eliminate ΔQ and $\Delta W_a/W_a$. This relation is

$$\frac{\Delta N}{N} = \frac{1}{\tau_2 D+1} \left(\frac{\Delta F_e}{F_e} - \frac{H_2}{H_e} \frac{\Delta T_2}{T_2} \right) \frac{1}{W_a'} \quad (19)$$

where, as shown in appendix B,

$$\tau_2 = \tau_3 = \frac{IN^2}{F_e W_a'} \quad (20)$$

Thus, from the thermodynamic development, the transfer function for the response of N to changes in F_e and T_2 is precisely defined in terms of steady-state variables.

Equations (18) and (19), when combined to eliminate $\Delta N/N$, give the following transfer function for the response of T_2 to changes in the independent variables:

$$\frac{\Delta T_2}{T_2} = \frac{\left[\left(\frac{\tau - a_1 W_a' \tau_2}{1 - a_1 W_a'} \right) D + 1 \right]}{\tau D+1} \left[\frac{(1 - a_1 W_a') H_e}{H_2} \right] \frac{\Delta F_e}{F_e} - \frac{a_2 W_a' H_e}{H_2} \frac{\tau_2 D+1}{\tau D+1} \left[\frac{\Delta A}{A} - \frac{H_t}{2H_3} \frac{\Delta F_t}{F_t} \right] \quad (21)$$

and equation (4), rewritten in this form with τ_2 equal to τ_3 , is

$$\frac{\Delta T_2}{T_2} = \frac{\tau_1 D+1}{\tau D+1} b_1 \frac{\Delta F_e}{F_e} + b_2 \left(\frac{\tau_2 D+1}{\tau D+1} \right) \left[\frac{\Delta A}{A} + \frac{b_3}{b_2} \frac{\Delta F_t}{F_t} \right] \quad (22)$$

Equations (18) and (19), when combined to eliminate $\Delta F_e/F_e$, give the following transfer function for the response of N to T_2 , A , and F_t :

$$\frac{\Delta N}{N} = \frac{1}{\frac{\tau - a_1 W_a' \tau_2}{1 - a_1 W_a'} D + 1} \frac{1}{1 - a_1 W_a'} \left\{ \frac{a_1 H_2}{H_e} \frac{\Delta T_2}{T_2} + a_2 \left[\frac{\Delta A}{A} - \frac{H_t}{2H_3} \frac{\Delta F_t}{F_t} \right] \right\} \quad (23)$$

Equations (18), (19), (21), and (23) are transfer functions that describe the engine dynamics in terms of a minimum of required data.

Relations among coefficients and time constants. - Equations (3) and (4) have been rewritten, as equations (17) and (22), to show relations among the coefficients and the time constants. Equations (21) and (22) are equal to one another and involve the same independent variables; corresponding terms are therefore equal. A similar correspondence exists between the terms of equations (17) and (18). The following relations therefore exist between the time constants and the coefficients:

$$\left. \begin{aligned} \tau_1 &= \frac{\tau - a_1 W_a' \tau_2}{1 - a_1 W_a'} \\ b_1 &= (1 - a_1 W_a') \frac{H_e}{H_2} \\ \frac{b_3}{a_3} &= \frac{b_2}{a_2} = -W_a' \frac{H_e}{H_2} \\ \frac{a_3}{a_2} &= \frac{b_3}{b_2} = -\frac{H_t}{2H_3} \end{aligned} \right\} \quad (24)$$

and (repeated for convenience) the relations given in equations (6) and (20)

$$\frac{b_1}{a_1} (\tau_1 - \tau) = \frac{b_2}{a_2} (\tau_2 - \tau) = \frac{b_3}{a_3} (\tau_3 - \tau) \quad (6)$$

$$\tau_2 = \tau_3 = \frac{IN^2}{F_e W_a'} \quad (20)$$

Equations (6), (20), and (24) summarize the relations that have been developed among the time constants and the coefficients.

Equation (6) is not an independent expression, but can be developed from equations (20) and (24) and is consistent with them. Equation (6) is presented because, as indicated in the discussion of the equation, the relation is of a general nature.

RESULTS AND DISCUSSION

Engine Dynamic Characteristics

The transfer functions of the engine are of a form for which specific dynamic characteristics can be obtained. One such dynamic characteristic that is useful in controls analysis is the response of a system to a step input (indicial response). Another important characteristic is frequency response.

The transfer functions of the engine are of two general forms, which are

$$\frac{\Delta Y}{Y} = \frac{\alpha D + 1}{\beta D + 1} c \frac{\Delta X}{X} \quad (25)$$

and, if α is zero,

$$\frac{\Delta Y}{Y} = \frac{1}{\beta D + 1} c \frac{\Delta X}{X} \quad (26)$$

Inasmuch as the properties of these transfer functions are well known, only the response of the functions to step changes in the independent variables will be discussed in detail.

Indicial response. - For step changes in the independent variables, transfer functions of the form of equations (25) and (26) lead to exponential curves similar to those presented in figure 1.

Final equilibrium conditions for a step input in the independent variables can be found from equations (25) and (26) by allowing D to approach zero and are $c \frac{\Delta X}{X}$, as shown in figure 1.

Initial conditions for a step input can be found from these equations by allowing D to approach ∞ . Thus, for transfer functions of the form of equation (26), the indicial response will be as shown in figure 1(a), where the initial response to a step input is zero. If $\alpha/\beta > 1$ in the transfer functions of the form of equation (25), the initial value of the dependent variable will be greater than the final value and the indicial response will be as shown in figure 1(b). Similarly, if $\alpha/\beta < 1$, the initial value of the dependent variable will be less than the final value and the indicial response will be as shown in figure 1(c).

The coefficient c in the transfer functions is a scale factor that could be incorporated in the ordinates of the curves of figure 1. In the general case, the coefficient c can be positive or negative and the ordinate can be interpreted consistent with the sign on this coefficient.

The transfer functions of the engine, as derived in the previous section, can now be interpreted in terms of the curves of figure 1. From equations (3) and (4), the initial and final values of the dependent variables for step changes in the independent variables can be found in the manner discussed for equations (25) and (26). The results of this procedure are presented in the following table:

Step change in	Variables constant	Response of engine speed		Response of turbine-outlet temperature	
		Initial value	Final value	Initial value	Final value
$\frac{\Delta F_e}{F_e}$	A, F_t	0	$a_1 \frac{\Delta F_e}{F_e}$	$\frac{\tau_1}{\tau} b_1 \frac{\Delta F_e}{F_e}$	$b_1 \frac{\Delta F_e}{F_e}$
$\frac{\Delta A}{A}$	F_e, F_t	0	$a_2 \frac{\Delta A}{A}$	$\frac{\tau_2}{\tau} b_2 \frac{\Delta A}{A}$	$b_2 \frac{\Delta A}{A}$
$\frac{\Delta F_t}{F_t}$	F_e, A	0	$a_3 \frac{\Delta F_t}{F_t}$	$\frac{\tau_3}{\tau} b_3 \frac{\Delta F_t}{F_t}$	$b_3 \frac{\Delta F_t}{F_t}$

This table shows that the indicial response of engine speed to changes in the independent variables will be of the form given

in figure 1(a). The indicial response of turbine-outlet temperature to changes in the independent variables will be of the form shown in figure 1(b) or 1(c), depending upon whether the ratio of the time constants is greater or less than 1.

In figure 1, no consideration was given to the possibility of negative values of α . For α to be negative, τ_1 , τ_2 , or τ_3 must be negative. From equation (20), however, τ_2 or τ_3 will not be negative unless W_a' is negative; W_a' is proportional to the slope of the steady-state relation between air flow and engine speed and, because these variables increase together, W_a' will be positive.

The first of equations (24) indicates the possibility of negative values of τ_1 . Negative values of τ_1 occur if an increase in engine fuel flow gives a reduction in the steady-state value of turbine-outlet temperature. This possibility exists only near idling engine speed when the coefficient b_1 , which is proportional to the steady-state relation between turbine-outlet temperature and engine fuel flow, may be negative. In the normal engine operating range, τ_1 will therefore be positive.

The relative values of the time constants are of interest, because, as previously explained, the ratios of the time constants, as compared with unity, determine whether the initial value of the indicial response is greater or less than the final value. Information concerning the ratios of the time constants can be obtained from a consideration of equations (24).

The first of equations (24) may be rewritten as

$$\frac{\tau_1}{\tau} = \frac{1 - a_1 W_a' \frac{\tau_2}{\tau}}{1 - a_1 W_a'} \quad (27)$$

As has been explained, W_a' is positive. The coefficient a_1 , which is proportional to the slope of the steady-state relation between engine speed and engine fuel flow, is also positive. Equation (27) therefore shows that if

$$\frac{\tau_1}{\tau} > 1$$

then

$$\frac{\tau_2}{\tau} < 1$$

or conversely, if

$$\frac{\tau_1}{\tau} < 1$$

then

$$\frac{\tau_2}{\tau} > 1$$

Therefore, as shown in the discussion of figure 1 and the preceding table, it can be concluded that if a step change in engine fuel flow causes the initial value of turbine-outlet temperature to be greater than the final value, a step change in either exhaust-nozzle area or tail-pipe-burner fuel flow will cause the initial value of turbine-outlet temperature to be less than the final value. Conversely, if a step change in either exhaust-nozzle area or tail-pipe-burner fuel flow causes the initial value of turbine-outlet temperature to be greater than the final value, a step change in engine fuel flow will cause the initial value of turbine-outlet temperature to be less than the final value.

The discussion of indicial response can be interpreted for inputs other than a step input. For example, for the frequency-response characteristic, if $\tau_1/\tau > 1$ there will be a phase lag between input and output and, conversely, if $\tau_1/\tau < 1$ there will be phase lead between input and output. It therefore follows for a turbojet engine with tail-pipe burning for steady-state sinusoidal inputs that, if turbine-outlet temperature leads engine fuel flow, this temperature will lag either exhaust-nozzle area or tail-pipe-burner fuel flow or, conversely, if turbine-outlet temperature lags engine fuel flow this temperature will lead either exhaust-nozzle area or tail-pipe-burner fuel flow.

Response for other engine types and other engine variables. - As explained in the discussion of equations (3), (4), and (6) in the section ANALYSIS, these equations can be extended to include dependent variables other than turbine-outlet temperature and engine speed for a turbojet engine with tail-pipe burning, or may be extended to other engine types.

Equation (27) applies for a turbojet engine with an axial-flow compressor and the results regarding indicial response apply only to such an engine. The same results may be obtained from equation (6), which holds for an engine with any type of compressor, if, from a physical consideration of the engine, positive or

negative signs are applied to the coefficients in this equation. As has been explained, the coefficient a_1 is positive and, in general, b_1 is also positive. From logic similar to that used to determine these signs, it is seen that a_2 is positive, b_2 is negative, a_3 is negative, and b_3 is positive. With these signs applied, equation (6) becomes

$$\left| \frac{b_1}{a_1} \right| (\tau_1 - \tau) = \left| \frac{b_2}{a_2} \right| (\tau - \tau_2) = \left| \frac{b_3}{a_3} \right| (\tau - \tau_3) \quad (28)$$

Equation (28) shows that if $\tau_1/\tau > 1$, then $\tau_3/\tau < 1$ or $\tau_2/\tau < 1$, or conversely. The conclusions previously reached concerning indicial response and frequency response therefore apply to all engines with tail-pipe burning.

Equation (6) may be applied to engines other than a turbojet engine with tail-pipe burning. For example, for the turbine-propeller engine, propeller-blade angle can be substituted for exhaust-nozzle area in equations (3) and (4). (The tail-pipe-fuel-flow term vanishes.) If the coefficients and the time constants are redefined, equation (6) can be used to determine whether the ratios of the time constants (τ_1/τ and τ_2/τ) are greater or less than 1. From a consideration of the steady-state characteristics of the turbine-propeller engine, it can be seen that (considering corresponding coefficients) a_1 , b_1 , and b_2 are positive and a_2 is negative. With these signs applied, an equation similar to equation (28) is obtained for the turbine-propeller engine. Therefore, for the turbine-propeller engine, if a step change in engine fuel flow causes the initial value of turbine-outlet temperature to be greater than the final value, a step change in propeller-blade angle will cause the initial value of turbine-outlet temperature to be less than the final value, and conversely.

Unpublished engine data show, in general, that for a step change in engine fuel flow the initial value of turbine-outlet temperature will be greater than the final value and, therefore, that for step changes in the other independent variables the initial value of turbine-outlet temperature will be less than the final value.

General Control Applications

The form of the engine transfer functions (equations (3) and (4)) can be directly used in setting up any general control

configuration. For this purpose, it is necessary that the dynamic characteristics of the engine be known. Equations (6), (22), and (26) can be used to determine much of the required information. These equations show that with either of the engine time constants τ or τ_1 determined from engine dynamic data, the dynamic characteristics of the engine can then be described in terms of a minimum of steady-state data. These dynamic characteristics can then be used in the synthesis of controls. Examples of the procedures and the techniques used in control synthesis are presented in references 4 and 5. The utility of the analysis presented herein, however, will be illustrated by applying the analysis to scheduled and noninteraction controls.

Scheduled Controls

Steady-state conditions for the turbojet engine with tail-pipe burning are determined by specific settings in the independent variables. It follows that, with one variable constant, unique relations exist between the two remaining variables for a given steady-state condition. It is on this basis that scheduled controls are possible for such an engine.

Relation between A and F_t . - From an operational viewpoint, it is desirable to operate an engine with tail-pipe burning at maximum engine speed and temperature over a range of tail-pipe-burner fuel flows and exhaust-nozzle areas. A schedule between exhaust-nozzle area and tail-pipe-burner fuel flow that accomplishes this aim is explicitly defined in equations (18) and (23) by the bracketed term, which includes these variables. This relation is

$$\frac{\Delta A}{A} = \frac{H_t}{2H_3} \frac{\Delta F_t}{F_t} \quad (29)$$

As is expected, for steady-state engine operation, exhaust-nozzle area and tail-pipe-burner fuel flow act in a similar, but opposite, manner. At constant engine fuel flow, the relation between exhaust-nozzle area and tail-pipe-burner fuel flow that maintains steady-state conditions is given by equation (29) and may be used as a basis for a scheduled control.

Relation between T_2 and F_e . - As is expected, a relation between turbine-outlet temperature and engine fuel flow exists that maintains constant engine speed. This relation is defined in equation (19) and is

$$\frac{\Delta F_e}{F_e} = \frac{H_2}{H_e} \frac{\Delta T_2}{T_2} \quad (30)$$

Equation (30) can be used as a basis for a scheduled control that maintains constant engine speed for a range of exhaust-nozzle areas. Such a control is of interest for engine operation when a variable-area exhaust nozzle is used as a means of improving the thrust-control characteristics of the engine. The schedule in equation (30) follows directly from the heat-balance equation for the engine and, in a sense, is a restatement of it.

The schedules presented in equations (29) and (30) can be used in closed-loop control systems in which error correction is applied only when the controlled variables deviate small amounts from the called-for conditions.

Noninteraction Controls

The utility of the analysis will now be illustrated by applying the analysis to noninteraction controls. In reference 6, the operational form for the engine and control characteristics is used both diagrammatically and algebraically to set up a general control configuration, to solve for the conditions required of the controllers, to eliminate interaction among the controlled variables, and to find the controller operational functions that give any desired system response action.

The problem of satisfactory control of the turbojet engine with tail-pipe burning involves the problem of interaction and multiple control because there are at least two degrees of freedom, or two engine variables, that can be simultaneously controlled. This interaction refers, in general, to the effect of one control loop on another control loop. In reference 6, that type of noninteraction is attained whereby any controlled variable setting affects only its corresponding controlled variable and no other controlled quantity. The method of reference 6 applies to continuous linear systems and may therefore be applied to the system considered herein.

Development of Control Functions

From reference 6, a general control configuration is assumed and is shown in schematic form in figure 2. The engine and the

control are represented as matrices, where the E's and C's are engine and control matrix elements, respectively. The input to a matrix box multiplies every element in its column. Any output is the sum of products in its row. The control system is generalized to this extent: (1) Two dependent engine variables (N and T₂) are to be controlled and one independent variable (F_t) is to be controlled; (2) the control system employs negative feedback in which errors are applied to the control; and (3) each error is to affect every independent variable.

It is useful to use the following algebraic equations for the system of figure 2:

$$\frac{\Delta Y_j}{Y_j} = \sum_{k=1}^3 E_{jk} \cdot X_k \quad \text{where } j = 1, 2$$

$$\frac{\Delta X_k}{X_k} = \sum_{v=1}^2 C_{kv} \cdot \left[\left(\frac{\Delta Y_v}{Y_v} \right)_s - \frac{\Delta Y_v}{Y_v} \right] + C'_{k3} \cdot \left[\left(\frac{\Delta X_3}{X_3} \right)_s - \frac{\Delta X_3}{X_3} \right] \quad \text{where } k = 1, 2, 3$$

(31)

The variables in equations (31) have been placed in a form consistent with the preceding development. The general variables in equations (31), in terms of engine variables, are

$$\frac{\Delta Y_1}{Y_1} = \frac{\Delta N}{N} \quad \frac{\Delta X_1}{X_1} = \frac{\Delta F_e}{F_e} \quad \left(\frac{\Delta Y_1}{Y_1} \right)_s = \left(\frac{\Delta N}{N} \right)_s$$

$$\frac{\Delta Y_2}{Y_2} = \frac{\Delta T_2}{T_2} \quad \frac{\Delta X_2}{X_2} = \frac{\Delta A}{A} \quad \left(\frac{\Delta Y_2}{Y_2} \right)_s = \left(\frac{\Delta T_2}{T_2} \right)_s$$

$$\frac{\Delta X_3}{X_3} = \frac{\Delta F_t}{F_t} \quad \left(\frac{\Delta X_3}{X_3} \right)_s = \left(\frac{\Delta F_t}{F_t} \right)_s$$

and

$$E_{11} = \frac{a_1}{\tau_{D+1}} \quad E_{12} = \frac{a_2}{\tau_{D+1}} \quad E_{13} = \frac{a_3}{\tau_{D+1}}$$

$$E_{21} = \frac{\tau_{1D+1}}{\tau_{D+1}} b_1 \quad E_{22} = \frac{\tau_{2D+1}}{\tau_{D+1}} b_2 \quad E_{23} = \frac{\tau_{3D+1}}{\tau_{D+1}} b_3$$

It can be seen that the first of equations (31) is simply equations (3) and (4) written in compact form. The second of equations (31) leads to the following equations:

1364

$$\left. \begin{aligned} \frac{\Delta F_e}{F_e} &= C_{11} \left[\left(\frac{\Delta N}{N} \right)_s - \frac{\Delta N}{N} \right] + C_{12} \left[\left(\frac{\Delta T_2}{T_2} \right)_s - \frac{\Delta T_2}{T_2} \right] + C'_{13} \left[\left(\frac{\Delta F_t}{F_t} \right)_s - \frac{\Delta F_t}{F_t} \right] \\ \frac{\Delta A}{A} &= C_{21} \left[\left(\frac{\Delta N}{N} \right)_s - \frac{\Delta N}{N} \right] + C_{22} \left[\left(\frac{\Delta T_2}{T_2} \right)_s - \frac{\Delta T_2}{T_2} \right] + C'_{23} \left[\left(\frac{\Delta F_t}{F_t} \right)_s - \frac{\Delta F_t}{F_t} \right] \\ \frac{\Delta F_t}{F_t} &= C_{31} \left[\left(\frac{\Delta N}{N} \right)_s - \frac{\Delta N}{N} \right] + C_{32} \left[\left(\frac{\Delta T_2}{T_2} \right)_s - \frac{\Delta T_2}{T_2} \right] + C'_{33} \left[\left(\frac{\Delta F_t}{F_t} \right)_s - \frac{\Delta F_t}{F_t} \right] \end{aligned} \right\} \quad (32)$$

The conditions (as obtained from reference 6) on the controls to attain the noninteraction conditions specified are as follows:

For a setting of N or T_2 to have no effect on F_t , equation (17a) in reference 6 gives

$$C_{31} = C_{32} = 0$$

for a setting of N to affect N only, equation (19) in reference 6 gives

$$\frac{C_{11}}{C_{21}} = - \frac{E_{22}}{E_{21}} = - \frac{b_2}{b_1} \frac{\tau_2 D + 1}{\tau_1 D + 1}$$

for a setting of T_2 to affect T_2 only, equation (19) in reference 6 gives

$$\frac{C_{12}}{C_{22}} = - \frac{E_{12}}{E_{11}} = - \frac{a_2}{a_1}$$

and for a setting of F_t to affect F_t only, equation (24) in reference 6 and equations (6), (20), and (24) herein give

$$\frac{C'_{13}}{C'_{33}} = - \frac{E_{13}E_{22} - E_{12}E_{23}}{E_{11}E_{22} - E_{12}E_{21}} = 0 \quad \text{or} \quad C'_{13} = 0$$

$$\frac{C'_{23}}{C'_{33}} = \frac{E_{13}E_{21} - E_{11}E_{23}}{E_{11}E_{22} - E_{12}E_{21}} = - \frac{a_3}{a_2}$$

(33)

It will be noted that the last of equations (33) is the schedule in equation (29). For convenience, the control matrix is redrawn in figure 3.

Controlled response action. - The preceding noninteraction conditions (equations (33)) give the required ratios between the elements of any column of the control matrix (fig. 3). In order to complete the analysis, it remains to choose any one element in each column. There is a freedom of independently choosing the response of each controlled variable to its corresponding setting. Any controller in the first column will determine engine-speed response; any controller in the second column will determine temperature response; and any controller in the third column will determine tail-pipe-burner fuel-flow response. The control functions can be determined from desired response wherein the response functions \mathcal{R} are defined as the response of the controlled variable to its setting. The response functions are therefore

$$\left. \begin{aligned} \frac{\Delta N}{N} &= \mathcal{R}_{11} \cdot \left(\frac{\Delta N}{N} \right)_s \\ \frac{\Delta T_2}{T_2} &= \mathcal{R}_{22} \cdot \left(\frac{\Delta T_2}{T_2} \right)_s \\ \frac{\Delta F_t}{F_t} &= \mathcal{R}'_{33} \cdot \left(\frac{\Delta F_t}{F_t} \right)_s \end{aligned} \right\} \quad (34)$$

It follows from reference 6 (equations (36) and (37)) and equation (6) presented herein that the control functions in terms of the desired response and the engine characteristics are

$$\left. \begin{aligned} C_{11} &= \frac{\mathcal{R}_{11}}{1-\mathcal{R}_{11}} \frac{E_{22}}{E_{11}E_{22}-E_{12}E_{21}} = \frac{\mathcal{R}_{11}}{1-\mathcal{R}_{11}} \frac{b_2(\tau_2^{D+1})}{a_1b_2-a_2b_1} \\ C_{12} &= \frac{\mathcal{R}_{22}}{1-\mathcal{R}_{22}} \frac{E_{12}}{E_{12}E_{21}-E_{11}E_{22}} = \frac{\mathcal{R}_{22}}{1-\mathcal{R}_{22}} \frac{a_2}{a_2b_1-a_1b_2} \\ C'_{33} &= \frac{\mathcal{R}'_{33}}{1-\mathcal{R}'_{33}} \end{aligned} \right\} \quad (35)$$

The remaining control functions for noninteraction conditions are determined from equations (33) presented herein. It therefore is theoretically possible to choose any desired response characteristics and to solve for the required control functions to achieve this response.

Analytical results applied to controls. - If the relations presented in equations (20) and (24) are combined with the control functions as determined from equations (33) and (35), the following equations for the control functions result:

$$\begin{aligned}
 C_{11} &= \frac{\mathcal{R}_{11}}{1-\mathcal{R}_{11}} W_{a'} (\tau_2 D+1) \\
 C_{21} &= -\frac{\mathcal{R}_{11}}{1-\mathcal{R}_{11}} \frac{b_1}{b_2} W_{a'} (\tau_1 D+1) \\
 C_{12} &= \frac{\mathcal{R}_{22}}{1-\mathcal{R}_{22}} \frac{H_2}{H_e} \\
 C_{22} &= -\frac{\mathcal{R}_{22}}{1-\mathcal{R}_{22}} \frac{H_2}{H_e} \frac{a_1}{a_2} \\
 C'_{23} &= -\frac{\mathcal{R}'_{33}}{1-\mathcal{R}'_{33}} \frac{a_3}{a_2} \\
 C'_{33} &= \frac{\mathcal{R}'_{33}}{1-\mathcal{R}'_{33}}
 \end{aligned} \tag{36}$$

Equations (36) give the control functions in terms of the desired response and the coefficients, the time constants, and the steady-state engine data previously discussed. The desired response functions (\mathcal{R}_{11} through \mathcal{R}'_{33}) are dictated by the engine control requirements and are chosen by the control designer to fulfill these requirements. Equations (36) show that if the response functions are chosen, all of the control functions, with the exception of C_{21} , will be determined from steady-state engine data. The determination of either τ_1 or τ is required to obtain the control function C_{21} .

Illustrative control. - As an illustration of the method of determination of the control function, let the response of engine speed setting \mathcal{A}_{11} be $\frac{1}{1+\delta_1 D}$, the response of temperature to temperature setting be $\frac{1}{1+\delta_2 D}$, and the response of tail-pipe fuel flow to a setting of tail-pipe and fuel flow, be $\frac{1}{1+\delta_3 D}$. Therefore, for example,

$$\frac{\mathcal{A}_{11}}{1-\mathcal{A}_{11}} = \frac{1}{\delta_1 D}$$

The control functions (equations (36)) then become

$$\left. \begin{aligned} C_{11} &= W_a' \frac{\tau_2}{\delta_1} \left(1 + \frac{1}{\tau_2 D} \right) \\ C_{21} &= -W_a' \frac{b_1}{b_2} \frac{\tau_1}{\delta_1} \left(1 + \frac{1}{\tau_1 D} \right) \\ C_{12} &= \frac{H_2}{H_e} \frac{1}{\delta_2 D} \\ C_{22} &= -\frac{H_2}{H_e} \frac{a_1}{a_2} \frac{1}{\delta_2 D} \\ C'_{23} &= -\frac{a_3}{a_2} \frac{1}{\delta_3 D} \\ C'_{33} &= \frac{1}{\delta_3 D} \end{aligned} \right\} \quad (37)$$

Equations (37) are the control functions required to give the first-order responses chosen. As has been previously explained, all of the control functions are determined from steady-state engine data, with the exception of C_{21} .

The form of the required control functions is given directly in equations (37). The control C_{11} , for example, which is the response of engine fuel flow to an engine-speed error (fig. 2), is a proportional-plus-integral control with the gain of the proportional element equal to

$$W_a' \frac{T_2}{\delta_1}$$

and the gain of the integral element equal to

$$W_a' \frac{1}{\delta_1}$$

The control C_{21} , which is the response of exhaust-nozzle area to an error in engine speed, is also a proportional-plus-integral control, with the gains on these elements determined as for C_{11} . It is noted that the gain on the integral element of this control can be found from steady-state data, but that determination of the gain on the proportional element requires a knowledge of the engine time constant T_1 . The remaining control functions (C_{12} , C_{22} , C'_{23} , and C'_{33}) are shown to be integral controls with gains as determined in equations (37).

SUMMARY OF RESULTS

The general form of engine transfer functions for a turbojet engine with tail-pipe burning was developed and relations among the coefficients and the time constants in these functions were found from the transfer functions and from engine thermodynamics.

1. By use of the developed relations it was shown that:

(a) The dominant dynamic characteristics of a turbojet engine with tail-pipe burning can be found from steady-state data and one transient relation.

(b) The transfer function that related engine speed to changes in engine fuel flow and turbine-outlet temperature is determined from steady-state operating data.

2. The transfer functions, when analyzed to determine indicial response characteristics, showed that, if a step change in engine fuel flow causes the initial value of turbine-outlet temperature to be greater than the final value, a step change in either exhaust-nozzle area or tail-pipe-burner fuel flow will cause the initial value of turbine-outlet temperature to be less than the final value, and conversely.

3. The results of the analysis, when applied to scheduled controls, gave:

- (a) A relation between exhaust-nozzle area and tail-pipe-burner fuel flow that maintains constant engine speed and temperature over a range of tail-pipe-burner operation
- (b) A relation between engine fuel flow and turbine-outlet temperature that maintains constant engine speed over a range of exhaust-nozzle area

4. The results when applied to the design of a closed-loop noninteracting control system gave the form of all the control functions and a solution in terms of steady-state data for six of the seven required control functions.

Lewis Flight Propulsion Laboratory,
National Advisory Committee for Aeronautics,
Cleveland, Ohio, March 29, 1950.

APPENDIX A

SYMBOLS

The following symbols are used in this report:

A	effective exhaust-nozzle area
$a_1, a_2, a_3,$ b_1, b_2, b_3	engine coefficients
C	control function to which engine-dependent-variable errors are applied
C'	control function to which engine-independent-variable errors are applied
c	general coefficient
D	differential operator, $\frac{d}{dt}$
E	engine-characteristic function
F_e	engine fuel flow in energy units per unit time
F_t	tail-pipe fuel flow in energy units per unit time
F, S, V, W	general functions
g	acceleration due to gravity
H	total enthalpy per pound of air flow
H_e	heat added by engine fuel flow per pound of air flow
H_t	heat added by tail-pipe-burner fuel flow per pound of air flow
I	polar moment of inertia of engine rotor
K_1, K_2, K_3, K_4	coefficients
M	Mach number at exhaust-nozzle throat

m	function of Mach number
N	engine rotor speed
P	total pressure
p	static pressure
Q	unbalanced engine torque
R	gas constant
\mathcal{R}	response function for controlled engine dependent variable
\mathcal{R}'	response function for controlled engine independent variable
T	total temperature
t	static temperature
W_a	air flow
X	engine independent variable
Y	engine dependent variable
α, β	general engine time constants
γ	ratio of specific heats
$\delta_1, \delta_2, \delta_3$	control time constants
$\tau, \tau_1, \tau_2, \tau_3$	engine time constants
Subscripts:	
1	compressor inlet (fig. 4)
2	turbine exit (fig. 4)
3	exhaust-nozzle throat (fig. 4)
e	engine

f	final value
i	initial value
j,k,v	indices
s	set value
t	tail pipe

APPENDIX B

DETAILS OF DEVELOPMENT

Algebraic Derivation of Response Equations

Engine speed. - The basic equations used in this development are

$$Q = \mathcal{F}(N, F_e, A, F_t) \quad (1)$$

$$Q = I \frac{dN}{dt} = I \frac{d}{dt} (N - N_0) \quad (B1)$$

If N_0 is the initial steady-state engine speed, equation (B1), in operational form, is

$$Q = I D(\Delta N) \quad (2)$$

where ΔN is an incremental change in engine speed. Equation (1), expanded and linearized around steady-state operating points, is

$$Q = \mathcal{F}_N \Delta N + \mathcal{F}_{F_e} \Delta F_e + \mathcal{F}_A \Delta A + \mathcal{F}_{F_t} \Delta F_t \quad (B2)$$

where \mathcal{F}_N , for example, is $\left(\frac{\partial Q}{\partial N} \right)_{F_e, A, F_t}$. Equation (B2), when com-

bined with equation (2), yields

$$ID - \mathcal{F}_N \Delta N = \mathcal{F}_{F_e} \Delta F_e + \mathcal{F}_A \Delta A + \mathcal{F}_{F_t} \Delta F_t \quad (B3)$$

Equation (B3) can be placed in the form

$$\left(-\frac{ID}{\mathcal{F}_N} + 1 \right) \frac{\Delta N}{N} = \left(-\frac{\mathcal{F}_{F_e} F_e}{\mathcal{F}_N N} \right) \frac{\Delta F_e}{F_e} + \left(-\frac{\mathcal{F}_A A}{\mathcal{F}_N N} \right) \frac{\Delta A}{A} + \left(-\frac{\mathcal{F}_{F_t} F_t}{\mathcal{F}_N N} \right) \frac{\Delta F_t}{F_t} \quad (B4)$$

The solution of the homogeneous equation determines the transient response of the engine to any of the forcing functions. The term $-I/\mathcal{F}_N$ has dimensions of time and is the time constant of the system considered. Thus

$$\tau = -\frac{I}{\mathcal{F}_N} \quad (B5)$$

Because equation (B4) is linear, the principle of superposition applies and the response of engine speed to changes in engine fuel flow is

$$\frac{\Delta N}{N} = \frac{1}{\tau D+1} \left(-\frac{\mathcal{F}_{F_e} F_e}{\mathcal{F}_N N} \right) \frac{\Delta F_e}{F_e} \quad (B6)$$

and from equilibrium conditions ($D \rightarrow 0$), it follows that

$$-\frac{\mathcal{F}_{F_e} F_e}{\mathcal{F}_N N} = \frac{\Delta N/N}{\Delta F_e/F_e} \quad (B7)$$

which is the slope of a steady-state operating curve relating engine speed to engine fuel flow at constant A and F_t , considered at the initial steady-state operating condition. The coefficients of the remaining terms of equation (B4) can be shown to be related to the slope of steady-state operating curves in the manner shown by equation (B7). Equation (B4), solved for the response of engine speed, then becomes

$$\frac{\Delta N}{N} = \frac{a_1}{\tau D+1} \frac{\Delta F_e}{F_e} + \frac{a_2}{\tau D+1} \frac{\Delta A}{A} + \frac{a_3}{\tau D+1} \frac{\Delta F_t}{F_t} \quad (3)$$

Turbine-outlet temperature or other variables. - The response of any other engine variable, such as turbine-outlet temperature, will be of a form of the sum of effects due to changes in the independent variables. The response of turbine-outlet temperature to changes in the independent variables may be found in the following manner: From the hypothesis presented in reference 1, it follows that

$$Q = \mathcal{S}(N, T_2, A, F_t) \quad (B8)$$

and in a manner similar to that used to obtain equation (B3), equation (B8) becomes

$$\left(\text{ID} - \mathcal{S}_N \right) \Delta N = \mathcal{S}_{T_2} \Delta T_2 \quad (\text{B9})$$

where $\Delta A = \Delta F_t = 0$.

Equation (B3), with ΔA and ΔF_t equal to zero, becomes

$$\left(\text{ID} - \mathcal{S}_N \right) \Delta N = \mathcal{S}_{F_e} \Delta F_e \quad (\text{B10})$$

Equations (B9) and (B10), divided by one another to eliminate ΔN and solved for the response of temperature to changes in engine fuel flow, give

$$\Delta T_2 = \frac{\text{ID} - \mathcal{S}_N}{\text{ID} - \mathcal{S}_N} \frac{\mathcal{S}_{F_e}}{\mathcal{S}_{T_2}} \Delta F_e \quad (\text{B11})$$

From the development of equation (3), it follows that equation (B11) is of the form

$$\frac{\Delta T_2}{T_2} = \frac{\tau_1 D + 1}{D + 1} b_1 \frac{\Delta F_e}{F_e} \quad (\text{B12})$$

where

$$\tau_1 = - \frac{I}{\mathcal{S}_N}$$

and b_1 is the slope of the steady-state relation between T_2 and F_e at constant A and F_t . The response of T_2 to changes in A and F_t can be found in a similar manner.

The response of any variable to changes in the independent variables can be found in a manner similar to that described for T_2 . The procedure for obtaining these expressions can be summarized in the following manner: Expressions for unbalanced torque as a function of the independent variables are written in which the dependent variable for which the response is desired is successively substituted for each independent variable. These expressions are

$$\left. \begin{aligned}
 Q &= \mathcal{F}(N, F_e, A, F_t) \\
 Q &= \mathcal{G}(N, Y, A, F_t) \\
 Q &= \mathcal{H}(N, F_e, Y, F_t) \\
 Q &= \mathcal{V}(N, F_e, A, Y)
 \end{aligned} \right\} \quad (B13)$$

where Y is any dependent variable.

These expressions for unbalanced torque are then expanded in a manner similar to that previously described and placed in a form similar to that of equations (B9) and (B10). The process used to obtain equation (B12) is then repeated. By this procedure the response of any variable to changes in the independent variables is obtained.

The responses of engine speed and turbine-outlet temperature are

$$\frac{\Delta N}{N} = \frac{a_1}{\tau_{D+1}} \frac{\Delta F_e}{F_e} + \frac{a_2}{\tau_{D+1}} \frac{\Delta A}{A} + \frac{a_3}{\tau_{D+1}} \frac{\Delta F_t}{F_t} \quad (3)$$

$$\frac{\Delta T_2}{T_2} = \frac{\tau_{1D+1}}{\tau_{D+1}} b_1 \frac{\Delta F_e}{F_e} + \frac{\tau_{2D+1}}{\tau_{D+1}} b_2 \frac{\Delta A}{A} + \frac{\tau_{3D+1}}{\tau_{D+1}} b_3 \frac{\Delta F_t}{F_t} \quad (4)$$

where a_1 through b_3 are slopes of steady-state relations among the variables and τ through τ_3 are transient relations.

Relations among coefficients and time constants. - Relations among the coefficients and the time constants in equations (3) and (4) can be obtained by solving these equations for equilibrium conditions and for the response of the dependent variables to step changes in the independent variables. Equilibrium conditions can be found by allowing D to approach zero in equations (3) and (4). These equations then become

$$\frac{\Delta N_f}{N} = a_1 \frac{\Delta F_e}{F_e} + a_2 \frac{\Delta A}{A} + a_3 \frac{\Delta F_t}{F_t} \quad (B14)$$

$$\frac{\Delta T_{2,f}}{T_2} = b_1 \frac{\Delta F_e}{F_e} + b_2 \frac{\Delta A}{A} + b_3 \frac{\Delta F_t}{F_t} \quad (B15)$$

and for step changes in the independent variables in equations (3) and (4), the initial changes in the dependent variables are obtained from equations (3) and (4) by allowing D to approach infinity.

$$\frac{\Delta N_1}{N} = 0 \quad (B16)$$

$$\frac{\Delta T_{2,i}}{T_2} = \frac{\tau_1}{\tau} b_1 \frac{\Delta F_e}{F_e} + \frac{\tau_2}{\tau} b_2 \frac{\Delta A}{A} + \frac{\tau_3}{\tau} b_3 \frac{\Delta F_t}{F_t} \quad (B17)$$

An equation similar to equation (B2) can be developed for the response of T_2 to changes in N , F_e , A , and F_t by substituting ΔT_2 for Q in equation (1). This function expanded and linearized around steady-state operating points is

$$\frac{\Delta T_2}{T_2} = K_1 \frac{\Delta N}{N} + K_2 \frac{\Delta F_e}{F_e} + K_3 \frac{\Delta A}{A} + K_4 \frac{\Delta F_t}{F_t} \quad (B18)$$

Equation (B18) is general and holds for equilibrium conditions and for the response of T_2 to step changes in the independent variables.

If equations (B14) and (B15) are combined with equation (B18) to eliminate $\Delta N/N$ and $\Delta T_2/T_2$, the relation for final conditions is

$$(b_1 - a_1 K_1) \frac{\Delta F_e}{F_e} + (b_2 - a_2 K_1) \frac{\Delta A}{A} + (b_3 - a_3 K_1) \frac{\Delta F_t}{F_t} = K_2 \frac{\Delta F_e}{F_e} + K_3 \frac{\Delta A}{A} + K_4 \frac{\Delta F_t}{F_t} \quad (B19)$$

and in a similar manner, from equations (B16) and (B17), the relation for initial response is

$$\frac{\tau_1}{\tau} b_1 \frac{\Delta F_e}{F_e} + \frac{\tau_2}{\tau} b_2 \frac{\Delta A}{A} + \frac{\tau_3}{\tau} b_3 \frac{\Delta F_t}{F_t} = K_2 \frac{\Delta F_e}{F_e} + K_3 \frac{\Delta A}{A} + K_4 \frac{\Delta F_t}{F_t} \quad (B20)$$

The right sides of equations (B19) and (B20) are identical and therefore the coefficients on similar terms of the left sides are equal. If the coefficients on corresponding terms are set equal to one another and solved for K_1 , the following relations among the terms in equations (3) and (4) result:

$$\frac{b_1}{a_1} (\tau_1 - \tau) = \frac{b_2}{a_2} (\tau_2 - \tau) = \frac{b_3}{a_3} (\tau_3 - \tau) \quad (6)$$

Thermodynamic Equations

Engine heat balance. - The engine-heat-balance equation for nonequilibrium operating conditions follows directly by equating unbalanced torque times engine speed to the difference between turbine and compressor power. If air flow is assumed equal to gas flow, the resultant expression is

$$H_e = \frac{F_e}{W_a} = \frac{QN}{W_a} + H_2 - H_1 \quad (7)$$

Equation (7) differentiated with H_1 constant is

$$\frac{dF_e}{W_a} - \frac{F_e}{W_a} \frac{dW_a}{W_a} = Q \frac{dN}{W_a} - \frac{QN}{W_a} \frac{dW_a}{W_a} + \frac{N}{W_a} dQ + dH_2 \quad (B21)$$

For deviation around steady-state conditions, the differentials in the equation are differential deviations from steady-state conditions and the remaining quantities are values of the variables at the initial steady-state condition. If deviations from steady-state conditions are considered ($Q = 0$), equation (B21) with specific heat assumed constant reduces to

$$\frac{dF_e}{F_e} - \frac{dW_a}{W_a} = \frac{N}{F_e} dQ + \frac{H_2}{H_e} \frac{dT_2}{T_2} \quad (10)$$

Equation (10), placed in linear form by considering incremental changes in the variables, is

$$\frac{\Delta F_e}{F_e} - \frac{\Delta W_a}{W_a} = \frac{N}{F_e} \Delta Q + \frac{H_2}{H_e} \frac{\Delta T_2}{T_2} \quad (14)$$

In this equation, ΔQ is the difference between final and initial unbalanced torque and because initial conditions are steady state, ΔQ is equal to Q .

Response of N to F_e and T_2 . - The response of N to F_e and T_2 can be developed from equation (10) if it is assumed that the engine has an axial-flow compressor. The relation between W_a and N for such an engine is

$$\frac{\Delta W_a}{W_a} = W_a' \frac{\Delta N}{N}$$

If this substitution is made in equation (14) and the expression for Q given by equation (2) is also substituted, Q and $\Delta W_a/W_a$ can be eliminated from equation (14) to give the following expression

$$\left(1 + \frac{IN^2}{F_e W_a'} D\right) \frac{\Delta N}{N} = \frac{1}{W_a'} \left(\frac{\Delta F_e}{F_e} - \frac{H_2}{H_e} \frac{\Delta T_2}{T_2}\right) \quad (B22)$$

In equation (B22) the factor $IN^2/F_e W_a'$ is the engine time constant at constant T_2 and F_e . Because neither A nor F_t is involved in this development, it follows that either of the restrictions that F_t is constant or A is constant can be placed in this definition and therefore

$$\tau_2 = \tau_3 = \frac{IN^2}{F_e W_a'} \quad (20)$$

Equation (B22) solved for the response of N to changes in F_e or T_2 becomes

$$\frac{\Delta N}{N} = \frac{1}{\tau_2 D + 1} \left(\frac{\Delta F_e}{F_e} - \frac{H_2}{H_e} \frac{\Delta T_2}{T_2}\right) \frac{1}{W_a'} \quad (19)$$

Differentiation and linearization of nozzle equation. - From continuity of flow it follows that

$$W_a = \frac{p_3 A M}{\sqrt{t_3}} \sqrt{\frac{\gamma_3 g}{R}} \quad (9)$$

Logarithmic differentiation of equation (9) with $\sqrt{\frac{\gamma_3 g}{R}}$ considered constant gives

$$\frac{dW_a}{W_a} = \frac{dp_3}{p_3} + \frac{dA}{A} + \frac{dM}{M} - \frac{1}{2} \frac{dt_3}{t_3} \quad (B23)$$

but

$$t_3 = T_3 \left(1 - \frac{\gamma_3 - 1}{2} M^2 \right)^{-1}$$

which differentiated is

$$\frac{dt_3}{t_3} = \frac{dT_3}{T_3} - \frac{(\gamma_3 - 1) M^2}{1 + \frac{\gamma_3 - 1}{2} M^2} \frac{dM}{M}$$

also

$$p_3 = P_3 \left(1 + \frac{\gamma_3 - 1}{2} M^2 \right)^{\frac{\gamma_3}{1 - \gamma_3}}$$

which differentiated and solved for dM/M is

$$\frac{dM}{M} = \left(\frac{dp_3}{p_3} - \frac{dp_3}{p_3} \right) \frac{1 + \frac{\gamma_3 - 1}{2} M^2}{\gamma_3 M^2}$$

If the expressions for dt_3/t_3 and dM/M are substituted in equation (B23), the following expression results

$$\frac{dW_a}{W_a} = \frac{dA}{A} + \frac{dp_3}{p_3} - \frac{1}{2} \frac{dT_3}{T_3} + \left(\frac{dp_3}{p_3} - \frac{dp_3}{p_3} \right) \left[\frac{1}{\gamma_3} \left(\frac{1}{M^2} - 1 \right) \right] \quad (13)$$

REFERENCES

1. Otto, Edward W., and Taylor, Burt L., III: Dynamics of a Turbo-jet Engine Considered as a Quasi-Static System. NACA TN 2091, 1950.
2. Taylor, Burt L., III, and Oppenheimer, Frank L.: Investigation of Frequency-Response Characteristics of Engine Speed for Typical Turbine-Propeller Engine. NACA TN 2184, 1950.

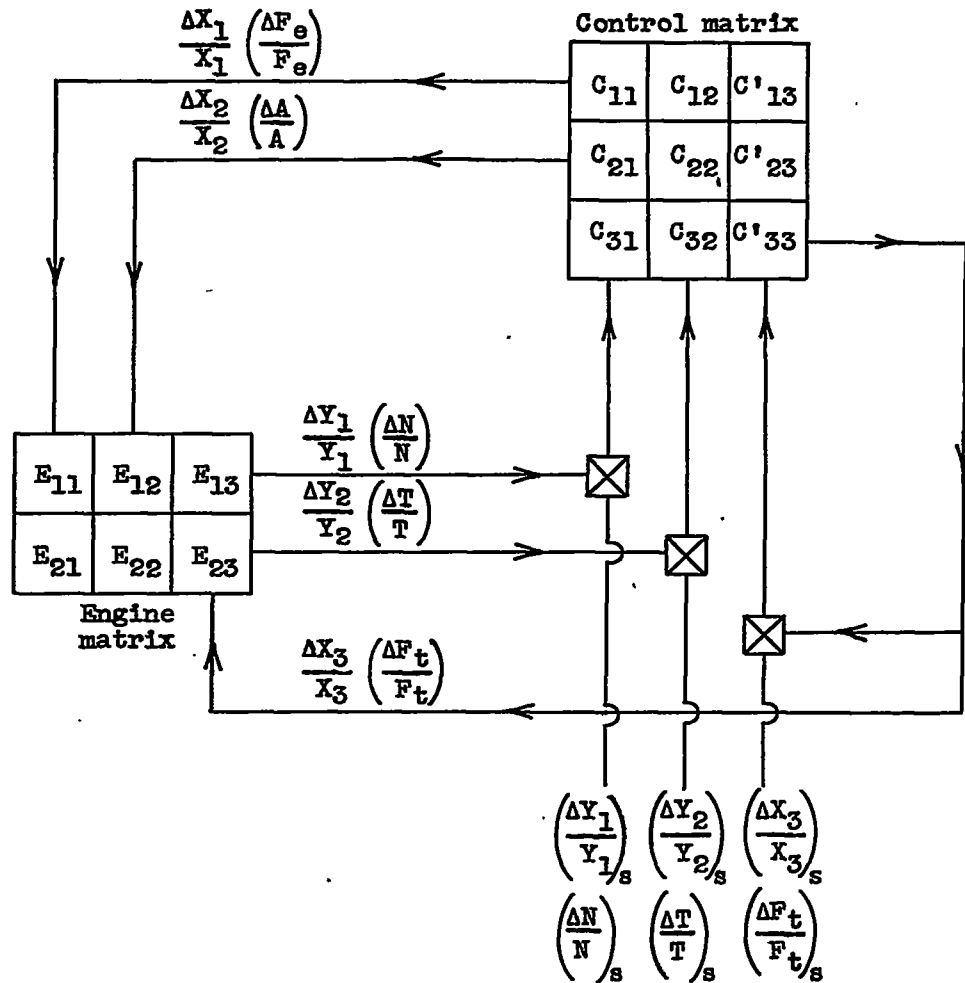

Figure 2. - Controlled-engine-system configuration.

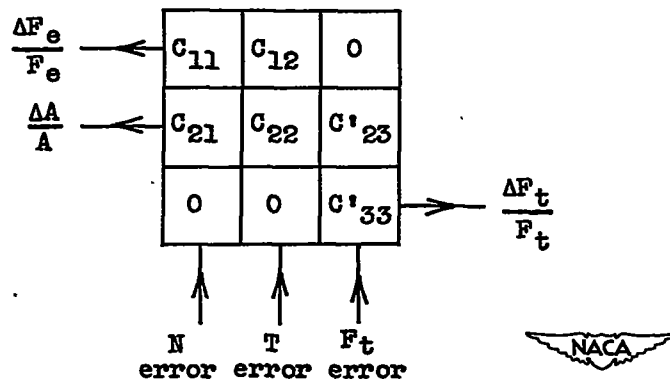

Figure 3. - Representation of specific control system.

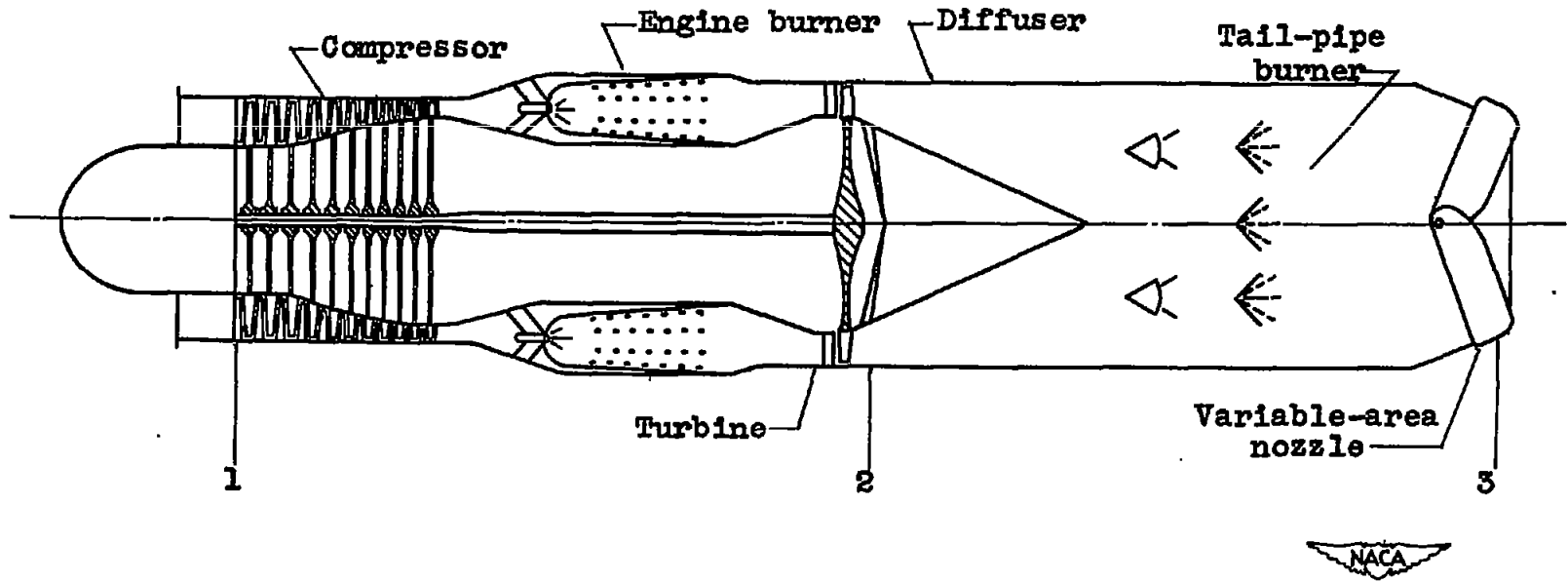

Figure 4. - Diagrammatic sketch of turbojet engine with tail-pipe burner.