

3.N21/5:6/2496

NACA TN 2496

NATIONAL ADVISORY COMMITTEE FOR AERONAUTICS

TECHNICAL NOTE 2496

FLIGHT INVESTIGATION OF A MECHANICAL FEEL DEVICE
IN AN IRREVERSIBLE ELEVATOR CONTROL
SYSTEM OF A LARGE AIRPLANE

By B. Porter Brown, Robert G. Chilton,
and James B. Whitten

Langley Aeronautical Laboratory
Langley Field, Va.



Washington

October 1951

~~CONFIDENTIAL~~

OCT 15 1951

BUSINESS, SCIENCE
& TECHNOLOGY DEPT.

NATIONAL ADVISORY COMMITTEE FOR AERONAUTICS

TECHNICAL NOTE 2496

FLIGHT INVESTIGATION OF A MECHANICAL FEEL DEVICE
IN AN IRREVERSIBLE ELEVATOR CONTROL
SYSTEM OF A LARGE AIRPLANE

By B. Porter Brown, Robert G. Chilton,
and James B. Whitten

SUMMARY

The longitudinal stability and control characteristics of a large airplane have been measured with a mechanical feel device in combination with a booster incorporated in the elevator-control system. Tests were made to investigate the feasibility of eliminating the aerodynamic control forces through use of a booster and providing control-feel forces mechanically. The feel device consisted of a centering spring which restrained the control stick through a linkage which was changed as a function of the dynamic pressure. Provisions were made for trimming and for manual adjustment of the force gradient. The system was designed to approximate the control-force characteristics that would result with a conventional elevator control with linear hinge-moment characteristics.

During the tests, the over-all performance of the feel device was satisfactory. The control effort of the pilot was completely dependent upon the feel-device setting, but the stick-fixed stability was not appreciably affected by the device. The stick-fixed characteristics of the airplane without the feel device, however, were satisfactory. The original conventional control system of the test airplane exhibited certain undesirable stick-force characteristics which resulted from nonlinear hinge-moment variations which were improved or corrected by the feel device. The feel device provided smoother landings with less pilot effort and improved the stick-force characteristics in maneuvers.

The manual adjustment on the feel device was used to investigate the desirable limits of force per g for bomber airplanes. The results of these tests confirmed previous tests which were the basis for the military requirements on force per g.

INTRODUCTION

Large control forces and control forces with unsatisfactory variations have become a great problem in airplane design because of the growing size and weight of aircraft, and increasing flight speeds. One method by which these large forces can be reduced is through the use of a booster-control system, and there is a trend toward the use of these systems in present-day airplanes.

When boosters are used, pilot's control forces can be provided by two distinct methods. In one method a given percentage of the aerodynamic hinge moment on the control surface is fed back to the pilot's stick. This method has been investigated and is reported in reference 1. In the other method, the booster eliminates the aerodynamic-force feedback and the stick forces are created mechanically. This method is advantageous when the aerodynamic hinge-moment variations are unsatisfactory.

A flight investigation of a mechanical feel device in combination with a booster installed in a bomber airplane has been made at the Langley Laboratory to gain experience with this type of control system and to determine the design features that should be incorporated in such feel devices in order to obtain satisfactory handling qualities. The tests also provided more evidence on which to base requirements for control forces for large bomber airplanes. Results of this investigation are presented herein.

SYMBOLS

α_T	angle of attack of tail, degrees
δ_e	elevator deflection, degrees
$\dot{\delta}_e$	rate of change of control deflection, degrees per second
δ_s	control-stick deflection, degrees
δ_t	trim-tab deflection, degrees
b_e	elevator span, feet
\bar{c}_e	elevator root-mean-square chord, feet
q	dynamic pressure, pounds per square foot or inches of water

- F force supplied by torsion bar, pounds
- F_s stick force, pounds
- H total elevator hinge moment, foot-pounds
- C_h hinge-moment coefficient $\left(\frac{H}{qb_e \bar{c}_e^2} \right)$

$$C_{h\alpha_T} = \frac{\partial C_h}{\partial \alpha_T}$$

$$C_{h\delta_e} = \frac{\partial C_h}{\partial \delta_e}$$

$$C_{h\dot{\delta}_e} = \frac{\partial C_h}{\partial \dot{\delta}_e}$$

$$C_{h\delta_t} = \frac{\partial C_h}{\partial \delta_t}$$

- a torque-arm length, feet
- x linear displacement of point A in feel system (see fig. 1), feet
- y linear displacement of point B in feel system (see fig. 1), feet
- θ angular displacement of torsion bar, radians
- l extension of push rod (for trimming), feet
- K_1 spring constant of torsion bar, foot-pounds per radian
- K_2 gearing constant relating x to δ_s , feet per degree
- K_3 variation of torque-arm length with q, pounds
- K_4 variation of l with δ_t , feet per degree
- K_5 variation of control-stick position with elevator deflection

$$K_6 = \frac{K_1 K_2 K_5}{K_3}$$

$$K_7 = \frac{K_1 K_4}{K_3}$$

K_8 variation of δ_e with q for steady flight, degrees pounds per square foot

K_9 variation of α_T with q for steady flight, degrees pounds per square foot

K_{10} variation of stick force with hinge moment, pounds per foot-pound

$$K_{11} = K_{10} K_8 C_{h\delta_e} b_e \bar{c}_e^2$$

$$K_{12} = K_{10} K_9 C_{h\alpha_T} b_e \bar{c}_e^2$$

$$K_{13} = K_{10} C_{h\delta_t} b_e \bar{c}_e^2$$

K_{14} gearing constant relating F_s with F

$$K_{15} = K_{14} K_6 K_8$$

$$K_{16} = K_{14} K_7$$

DESCRIPTION OF APPARATUS

Theoretical Design Principle

The basic purpose in the design of the feel device was to produce a mechanical arrangement which would provide forces that would vary with indicated airspeed, control position, and trim-device setting in a manner similar to the force variation in a satisfactory conventional aerodynamic-control system. Such a variation was achieved by the use of a centering spring which was geared to the control stick through a

variable linkage. Figure 1 shows a drawing which embodies the principles of the test feel device.

The similarity between the forces of the mechanical system and the aerodynamic system can best be illustrated by comparing the factors which make up the stick forces in both systems. In the conventional elevator system with a trim tab, the moment equation from which the stick force arises can be written as follows:

$$H = \delta_e C_{h\delta_e} q b_e \bar{c}_e^2 + \alpha_T C_{h\alpha_T} q b_e \bar{c}_e^2 + \delta_t C_{h\delta_t} q b_e \bar{c}_e^2 \quad (1)$$

The terms $C_{h\delta_e}$, $C_{h\alpha_T}$, and $C_{h\delta_t}$ are assumed to remain constant throughout the speed range.

With the aid of figure 1, the force provided by the feel device can be expressed as follows:

$$F = \frac{K_1 \theta}{a}$$

but, since $\theta \approx \frac{y}{a}$, $y = x + l$, and $x = K_2 \delta_s$,

$$y = K_2 \delta_s + l$$

$$\theta = \frac{K_2 \delta_s + l}{a}$$

and

$$F = K_1 \frac{K_2 \delta_s + l}{a^2}$$

A mechanism was added to the feel device to make a vary as a function of the dynamic pressure.

If $a = \sqrt{\frac{K_3}{q}}$ and $l = K_4 \delta_t$

$$F = \frac{K_1 (K_2 \delta_s + K_4 \delta_t) q}{K_3}$$

and, if $\delta_s = K_5 \delta_e$,

$$F = K_6 \delta_e q + K_7 \delta_t q \quad (2)$$

This equation has the same form as that for the conventional elevator control except for the absence of the angle-of-attack term in the feel-device formula. A term simulating this effect, however, could easily be included through the use of a bobweight on the stick.

In order to compare the force variation with speed as provided by each system in straight flight, the expressions in both cases are simplified still further by the theoretical relationships $\delta_e = \frac{K_8}{q}$ and $\alpha_T = \frac{K_9}{q}$ as follows:

For the aerodynamic system, let

$$F_s = K_{10}H$$

then,

$$F_s = K_{11} + K_{12} + K_{13}\delta_t q \quad (3)$$

For the feel device, let

$$F_s = K_{14}F$$

then,

$$F_s = K_{15} + K_{16}\delta_t q \quad (4)$$

The final equations for both cases can be expressed graphically as shown in figure 2. The first two terms in the aerodynamic equation (equation (3)) provide a constant force and the third term adds to this constant force a force that varies in proportion to dynamic pressure.

In the case of the feel device (equation (4)), only one term provides the initial constant force to which is added a force that also varies as a function of dynamic pressure. As previously stated, an effect similar to that of the second term in equation (3) can be provided in equation (4) by the use of a bobweight on the control stick.

General Operation

The location of the mechanical feel device in the airplane is shown in figure 3. A semischematic scale drawing showing the operating component of the device in more detail is presented as figure 4. A torsion bar, which acts as the centering spring, is connected by a linkage system to the control column and supplies a force gradient with control-stick displacement. Force-gradient variation with dynamic pressure is achieved by varying the length of the torque arm as a function of the dynamic pressure. At any position of the control column the restraining

force may be trimmed to zero by means of an electrical trim motor. The trim motor drives a worm gear located in the linkage system to permit unloading of the torsion bar by extending or shortening one of the push-rods. A means for varying the magnitude of the force gradient to correspond to different effective values of elevator hinge-moment parameter $C_{h\delta_e}$ is provided in the design of the bell crank. The value of $C_{h\delta_e}$ is varied by changing the mechanical advantage between the control stick and the torsion bar. This principle is the same as that upon which the dynamic-pressure system operates with the exception that the link which varies $C_{h\delta_e}$ is manually controllable. When the adjustable bell-crank arm is rotated clockwise the force gradient is diminished by the greater mechanical advantage of the stick over the torsion bar.

Figure 5 shows a schematic drawing of the airspeed-sensing system for establishing the length of the torque arm as a function of the dynamic pressure. For the sake of clarity, the position of the device was drawn to represent a high-speed condition. In this system, a total-pressure tube is connected to the bellows shown in the figure. An increase in pressure expands the bellows and rotates the contact arm about point A in a counterclockwise direction. This rotation closes the lower set of contacts which operates the electrical actuator in a manner to move the roller closer to the torsion bar. This operation increases the force gradient because of the shorter torque-arm length. The ensuing motion of the roller, however, rotates the cam about point B in a clockwise direction and increases the tension in the spring connecting the cam to the contact arm. When the roller establishes the correct torque-arm length corresponding to the new airspeed, sufficient tension has been built up in the spring by the cam motion to return the contact arm to its neutral position. A decrease in pressure reverses the operation and the roller is moved away from the torsion bar to a new equilibrium position.

The damper shown in figures 3 and 4 was included in the system to simulate aerodynamic damping. In a conventional control system, the aerodynamic damping varies directly with speed. In the feel-device system there were only two methods by which damping could be included conveniently. Placing a damper on the control stick would have provided damping independent of airspeed. Placing a damper on the arm connected to the torsion bar would allow the damping to vary as the square of the airspeed. The latter method of applying damping was employed because this method was believed to approximate more closely the aerodynamic conditions.

The counterweight, shown in figure 4, was for the purpose of static mass balance. It should be noted here that the absence of the

counterweight would not result in a pure bobweight effect because the influence of the weight of the feel device on the stick forces would be dependent upon airspeed.

Design Characteristics

The torsion bar which supplied the force gradient was made up of two tubes, one inside of the other, welded together at one end. The other end of the larger tube was securely fastened to a rigid frame. The free end of the smaller tube was connected to the torque arm. Careful attention was given to mounting the torsion bar on the frame and also to the connection between the bar and torque arm in order to eliminate as much lost motion as possible. It is already known that excessive lost motion or backlash is a potential source of serious objections to mechanical feel systems.

The track in which the roller (fig. 5) moves was a circular arc. The arc prevented any deflection of the torsion bar when the roller was moved by a change in airspeed. Although extremely long torque-arm lengths are required at low speeds and extremely short lengths are required at very high speeds, the actual travel of the roller was restricted. The restrictions were necessary to avoid nonlinearities with large torque-arm lengths and to avoid backlash difficulties and high loads at short torque-arm lengths. Stops were placed on the torque arm at a low-speed position corresponding to about 80 miles per hour and a high-speed position corresponding to 335 miles per hour.

In the positioning system, which is sensitive to airspeed, the cam design determines the relationship between the dynamic pressure and the force gradient. The cam shape used in the test feel device was designed to make the force gradient vary directly with the dynamic pressure.

When the speed was changed, the time required for the electrical actuator to reach maximum velocity was approximately $1/5$ second. During operation at its maximum velocity the actuator changed the torque-arm length at a rate of about $1/2$ inch per second. This rate of change means that, at low speeds, the actuator would follow an airplane longitudinal acceleration of about $1.0g$ without introducing any lag in the system. At higher speeds the actuator would follow even larger accelerations. This rate was sufficient to compensate for any change in speed of the test airplane over the entire speed range. Figure 6 presents a ground calibration which shows the relationship between the torque-arm length and calibrated airspeed. At the low-speed end of the curve the figure shows that the torque arm had reached its stop and was constant for airspeeds below about 80 miles per hour. Similarly, above 335 miles per hour, the other stop was reached and the torque arm was again constant

for higher airspeeds. This curve shows the speed range over which the feel device provided the variation of force gradient with dynamic pressure. Below or above the limiting speed range the force gradient would be independent of dynamic pressure. Figure 6 also shows that at approximately 80 miles per hour a dead spot of about 15 miles per hour was present. This dead spot was caused by the clearance between the points of the reversing switches which operated the actuator. At the high-speed end this dead spot is scarcely detectable because, although a given change in dynamic pressure at low speeds results in a rather large change in airspeed, the same dynamic-pressure increment at high speeds results in a relatively small airspeed change.

The behavior of the contact arm (fig. 5) and the position of the roller (fig. 5) were recorded during the tests. As previously explained, the contact arm should be in neutral position when the roller is not moving. Airplane vibrations, however, caused the contact arm to oscillate about its neutral position so that it alternately opened and closed the contacts at a high frequency. This chatter in the switches tended to produce arcing across the points but it also reduced the dead spot previously discussed. The arcing across the points can be reduced by using a rectifier in the circuit. Figure 7 presents a typical flight record of the contact-arm behavior and the roller position. During the first part of the record, the roller position was constant and the chatter in the contacts is clearly shown near the top of the record. The roller position was not influenced by this chatter because the actuator could not respond to the high frequency of the chatter. The small oscillations shown in the roller-position trace were caused by vibration of the recording element and do not signify motion of the roller. The chattering stops near the middle of the test record because the contact arm has now been moved by a slight increase in dynamic pressure. As the dynamic pressure continues to increase the contact arm moves sufficiently to take up the clearance between the contacts and the actuator moves the roller.

It can be seen from the mechanics of the system that a failure in the follow-up system, such as loss of dynamic pressure, will not result in a complete loss of feel forces. If such a failure occurred, the actuator would move the roller back to the low-speed stop and would reduce the feel forces but not completely eliminate them.

In general, the airspeed-sensitive system used in the test feel device provided excellent speed-following characteristics. The device would follow a speed change of about 20 miles per hour per second. Such accurate speed following may not be essential for acceptable operation.

Figure 8 presents the ground calibration of the feel device in the form of pilot's stick force per degree of stick movement against calibrated airspeed. The device could be adjusted manually to provide any

force gradient between the A and C setting represented on the figure. The equivalent $C_{h\delta_e}$ range, derived from the previously mentioned

calibration, is also presented in figure 8. The device was designed so that $C_{h\delta_e}$ would be independent of airspeed but, in spite of efforts

to stiffen the structure and mounting, flexibility of the frame caused variations as shown in figure 8. The flexibility is believed to have entered into the present system chiefly between the control stick and the torsion bar (for example, deflection of the mounting point of the adjustable bell crank). Flexibility of this particular type would cause such $C_{h\delta_e}$ variations with speed as are shown in figure 8. In practice,

compensation for structural flexibility in the design of the cam would be possible. In the case of the present tests, the $C_{h\delta_e}$ variations

with speed obtained in ground tests were largely compensated for by the stretch in the cable system between the control stick and elevator. This effect will be discussed in more detail subsequently.

A close inspection of the mechanics of the device presented in figure 4 shows that the rate at which the trim motor eliminates the stick force associated with a given change in elevator deflection depends on the setting of the adjustable bell crank. The low force-gradient setting of the bell crank would provide the faster trimming action. The rate of trimming with this low force-gradient setting, in terms of elevator movement, was approximately $\frac{1}{2}^\circ$ per second which, in the pilot's opinion, was too slow.

Installation

The feel device was installed in the pilot's side (left side) of the elevator-control system of the bomber airplane. As can be seen in figure 3, the feel device was connected directly to the pilot's stick. The device was located as close to the pilot's stick as possible so that a complicated linkage system would not be necessary. Care was taken to eliminate as much lost motion as possible between the pilot's stick and the feel device. The backlash in the system was about 1° stick deflection. At 200 miles per hour this amount of stick motion would produce a normal acceleration change of about 0.06g. This magnitude of backlash was not objectionable to the pilot. A detailed explanation of the booster installation and the safety features provided in the system is given in reference 1.

The original test program called for tests of the feel device with the booster operating at infinite boost ratio so as to allow no

aerodynamic-force feedback from the elevators. This test procedure obviously would produce the best conditions under which the feel device could be judged. Ground tests, however, led to the belief that the investigation could not be made with the booster completely irreversible because a high-frequency stick oscillation would develop under these conditions when the stick was deflected and released. This oscillation, however, could be stopped easily by grasping the control wheel. Figure 9 presents a ground record of the stick position showing the oscillation. The figure shows that the amplitude actually increased during the run. Additional ground tests showed that the oscillation was well-damped when the booster was set on boost ratio 24; therefore, the tests were conducted with this setting.

Figure 10 presents force per g obtained in pull-ups and push-downs to illustrate by comparison that a boost ratio of 24 in substitution for infinite boost ratio did not allow, for practical purposes, any significant aerodynamic-force feedback. These results show that the flight data on the feel-device characteristics using boost ratio 24 were neither masked nor influenced by aerodynamic hinge moments. In the later stages of the program, however, it was discovered that infinite boost ratio did not cause any oscillations in flight as it did in the ground tests.

INSTRUMENTATION

Standard NACA recording instruments were used. The following table presents a list of these instruments and the quantities measured:

Measured quantity	NACA instrument
Stick position	Mechanical control position recorder
Elevator position	Electrical control position recorder
Feel-device effective torque-arm length	Electrical control position recorder
Contact closure	Solenoid
Booster-control-arm position	Mechanical control position recorder
Booster quadrant position	Mechanical control position recorder
Control-stick force	Strain-gage wheel force recorder
Airspeed	Airspeed recorder and indicator
Normal acceleration	Recording and indicating normal accelerometers
Pitch velocity	Pitch turnmeter
Time	Timer synchronizing all records

During these tests the airspeed was measured by means of the service system of the airplane. The flush static orifices, which are located on the sides of the fuselage, were calibrated for position error through use of a trailing airspeed bomb. The airspeed data presented herein have been corrected and, therefore, correspond to the reading of a standard indicator connected to a pitot-static tube which is free from position error.

TESTS, RESULTS, AND DISCUSSION

General

Three different force-gradient settings on the feel device were investigated in longitudinal-stability runs both in steady flight and accelerated flight at approximately 10,000 feet. Comparable tests were also made on the airplane configuration (without feel device or booster) in order to provide a standard by which the feel-device characteristics could be evaluated. All the tests were made for only two airplane configurations, clean normal rated power and landing. These configurations were chosen because they would provide the greatest speed and control-force ranges over which to test the feel device. Some landings were made to test the flight operation of the feel device under rapid control movement. The speed range covered by the tests was from about 300 miles per hour down to the stall. The airplane gross weight was about 110,000 pounds with the center-of-gravity location at 29 percent of the mean aerodynamic chord.

One phase of the tests consisted in determining whether the feel device would introduce any undesirable oscillatory characteristics in the control system. The oscillatory characteristics were investigated by means of a series of abrupt pull-ups and push-downs, each followed by release of the control stick. These maneuvers were made at 250 miles per hour in the clean condition for the airplane without the feel device or booster and for the airplane with each of the three force-gradient settings of the feel device. Time histories of the pitching velocity, normal acceleration, airspeed, stick force, and control position obtained during these maneuvers are presented in figure 11. As shown by the figure no undesirable oscillating tendencies developed as a result of the feel device. The damper on the test feel device provided a damping force that varied as the square of the airspeed. In terms of $C_{h_{\delta e}}$, the damping supplied in the dynamic-stability runs previously mentioned varied from about 0.00001 to 0.00002 per degree per second depending

upon the setting of the adjustable bell crank. These values of $C_{h_{\delta e}}$ were calculated for the airspeed, 250 miles per hour, at which the runs were made.

The measured static longitudinal stability characteristics for the airplane without feel device and booster and for the airplane with the three force-gradient settings of the feel device are presented in figure 12 for the airplane in the clean condition and in figure 13 for the landing condition. The horizontal axis has been shifted for each force curve in the interest of clarity. Stick force and elevator angle are plotted against calibrated airspeed, and stick force divided by dynamic pressure is plotted against airplane normal-force coefficient which is based on wing area. As expected, the stick-fixed characteristics were not altered by the presence of the feel device. The magnitudes of the stick forces, however, were dependent upon the force-gradient setting of the feel device. In addition, the device improved the stick-free stability at low speeds. This improvement can be seen in figure 14 which presents calculated stability for a trim speed of 160 miles per hour. These data were derived from figure 12 to show more clearly the effect of the device at low speeds. The curve for the airplane without the feel device or booster shows a reversal in slope of the stick-force curve at speeds below the trim speed. As shown by the curve for the feel device, this tendency of slope reversal is considerably reduced. The instability shown for the airplane without the feel device or booster was caused mainly by the unsatisfactory hinge moments. Since the aerodynamic hinge-moment effects were eliminated by the booster, the slight unstable tendency shown for the feel device was caused by the stick-fixed stability. This slight irregularity is not apparent in the elevator-angle data shown in figure 12 because the curve is faired to satisfy all of the test points and the scatter tends to mask such a trend.

Trim Characteristics

Static-longitudinal-stability data are presented in figure 15 to show the effect of the mechanical trimming device. For these runs the aerodynamic trim tab remained fixed in one position, and the airplane was trimmed at the three speeds, 170, 220, and 270 miles per hour, by means of the mechanical trimmer only. The tests were made with a constant force-gradient setting, B, on the feel device. The data are presented in the form of stick force divided by dynamic pressure plotted against normal-force coefficient, and elevator angle against normal-force coefficient. In tests of this type the stick-fixed stability should be expected to show essentially the same variation for each trim speed. The elevator-angle curve presented in figure 15 shows that the trim speed did not appreciably affect the stick-fixed stability. The

stick-force curves, however, would be expected to be changed by a constant force increment throughout the normal-force-coefficient range for each trim speed as can be seen from equation (4) in a foregoing section. The stick-force curves presented in figure 15 show that a change in trim speed from 270 miles per hour to 220 miles per hour results in the expected constant force increment between the curves. The curve presented for a trim speed of 170 miles per hour does not show the constant force increment; however, such a trend is evident and the trimming device is still effective through the test speed range. The indicated decrease in trimming effectiveness at the lower speed could possibly be accounted for by a slight change in center-of-gravity position because the data for the trim speed of 170 miles per hour were not obtained during the same flight in which the data for the other two trim speeds were obtained.

The pilot felt that the mechanical trimmer should provide a higher rate of motion than that in the present device because in landings the trimmer did not reduce the forces sufficiently fast to be considered entirely satisfactory. As mentioned previously, the rate of trimming was approximately $\frac{1}{2}^{\circ}$ of elevator motion per second.

Maneuvering Stability

The variations of stick force and elevator angle with normal acceleration (in g units) are presented in figure 16 for the airplane without the feel device or booster and for the airplane with the three force-gradient settings on the feel device. These data were obtained in maneuvers in which the pilot made a pull-up to a specified normal acceleration and maintained that acceleration for several seconds before returning the airplane to trimmed flight. Push-downs were also made in a similar manner. Data are shown for indicated airspeeds of 160, 200, and 250 miles per hour in figures 16(a), 16(b), and 16(c), respectively. The figures show the expected effect of the feel device on the force gradients. The force-gradient range considered satisfactory for the test airplane by the military services is from $22\frac{1}{2}$ to 50 pounds per g based on a limit load factor of 3. Inspection of the figures will show that the force gradient of the airplane without the feel device or booster was approximately 75 pounds per g at 200 miles per hour, whereas, at the same speed, setting C on the feel device provided a gradient of about 90 pounds per g. Throughout the test speed range, setting C provided a force gradient which was slightly higher than that of the airplane without the feel device or booster. Setting B supplied a force per g of about 70 pounds at 200 miles per hour and setting A provided a force per g of about 30 pounds. The pilots noted that setting A, the

only setting that supplied a force gradient which was completely within the previously mentioned specified limits, provided the most desirable force per g.

It should be pointed out that serious errors can be introduced in the expected stick forces by cable stretch if the booster is connected to the stick, as in the present tests, rather than to the control surface. For example, from figure 16(b) it can be seen that approximately 5° of elevator angle are required to produce a change in normal acceleration of 1 g at 200 miles per hour. Under these conditions, however, about 1.5° of stick motion was absorbed in cable stretch; therefore, a large stick deflection and more pilot exertion were necessary. The effect of this stretch on the stick forces is more easily seen in figures 16(b) and 16(c) than in 16(a). The variation of elevator angle with normal acceleration in both figures is linear; whereas the variation of stick force with normal acceleration is curved. The effect of cable stretch could be eliminated by locating the booster at the control surface.

Reference 1, which presents the booster tests without the mechanical feel device, shows that the airplane with the booster set at boost ratio 2.8 exhibited control forces which were mostly within the specified range. The data for that boost ratio have been taken from reference 1 and presented in figure 17 in comparison with setting A on the feel device (with boost ratio 24). It should be noted, however, that the tests of reference 1 were made with the center of gravity located at about 25 percent of the mean aerodynamic chord. This comparison is shown in this paper because the pilot noted that the boost-ratio-2.8 condition and setting A of the feel device were similar in the normal cruising speed range (200 to 220 mph) but at low speeds (from 100 mph to stall) the boost ratio 2.8 was superior to the feel device. The figure shows that, in the speed range for which the pilot noted the similarity, the difference in the values of stick force per g for the two conditions is not sufficiently large to be noticeable by the pilot. At the low-speed end of the curve, however, the boost-ratio-2.8 condition approaches a much lower value than the condition for setting A. A small difference at low airspeed is appreciated by the pilot especially during a landing since one hand may be needed to adjust the throttles or trim tabs and only one hand would be free to fly the airplane.

Elevator Overbalance

As was previously mentioned in this paper, combinations of feel device and booster are particularly useful when the hinge-moment variations are undesirable. In addition, because of the extreme complications and compromises involved in an attempt to obtain good hinge-moment characteristics by aerodynamic balancing, even the most carefully

designed control systems using aerodynamic balance may have some undesirable characteristics. For example, figure 18, in which stick force and elevator angle for the test airplane are plotted against normal acceleration, shows that overbalance was encountered with the original control system of the test airplane in the approach condition. The figure also shows a calculated force curve that would result through use of the test feel device. The feel device would provide satisfactory forces in this case because the stick-fixed stability is satisfactory. The figure shows that the stick-fixed stability was satisfactory throughout the run. It is reasonable, therefore, to conclude that, in this case, a feel device would remedy the problem of elevator overbalance because satisfactory forces supplied by a feel device depend wholly upon stable stick-fixed characteristics.

Landings

In landings made with the conventional elevator-control system, the large hinge moments resulting from large elevator deflections are counteracted by an appreciable increase in the up-floating tendency of the elevator at high angles of attack. This effect prevents uncontrollably large forces in landings. As previously mentioned, however, the test feel device had no provision to simulate the negative increase in $C_{h_{out}}$ at high angles of attack. Relatively large stick forces,

therefore, could possibly be expected in landings with the feel device even though the feel forces in normal flight are satisfactory. Several landings were made with and without the feel device. Time histories of stick force, elevator angle, normal acceleration, pitching velocity, and airspeed obtained during landings are presented in figure 19 for the airplane without the feel device or booster and the three force gradients supplied by the feel device. The figure shows that approximately 90 pounds force was exerted by the pilot during the landing made with the original control system. Of course, the control forces experienced in the landings made with the feel device were changed in accordance with the feel-device setting. The highest setting of the feel device, which provided a force gradient even higher than that of the original control system, required about 70 pounds of pilot effort during the landing. In the landing made with the middle force-gradient setting, a force of about 60 pounds was applied by the pilot; whereas the lowest gradient setting required only 35 pounds force. During all the landings the pilot attempted to trim out the stick forces up to the flare. The pilot commented that the electrical trim on the feel device was more convenient to use than the aerodynamic trim tab. This fact probably accounts for the landing forces for setting C being smaller than the landing forces for the airplane without feel device or booster. In addition, the control friction which existed during landings with the

airplane was overcome by the feel device in combination with a booster so that smoother operation of the airplane resulted.

SUMMARY OF RESULTS

The flight investigation of a mechanical feel device in combination with a booster incorporated in the elevator control system of a large airplane gave the following results:

1. The feel device did not alter the stick-fixed characteristics, but magnitudes of the stick forces were dependent upon the feel-device setting because the aerodynamic hinge moments were overcome by the booster.
2. The backlash, or the angle through which the control stick could be moved before the feel device came into action, was approximately 1° . This backlash would result in a normal-acceleration change of 0.06g at 200 miles per hour. This magnitude of backlash was not considered objectionable by the pilot.
3. The airspeed-sensitive system of the test feel device exhibited excellent speed-following characteristics. The device would follow a change in airspeed of about 20 miles per hour per second. Such high speed-following ability may not be essential to satisfactory operation.
4. The rigidity of the feel-device mounting should be given consideration in the original feel-device design.
5. The damping in the test feel device was satisfactory. In terms of the variation of hinge moment with rate of change of control deflection, the values of damping at 250 miles per hour varied from about 0.00001 to 0.00002 depending upon the setting of the adjustable bell crank.
6. The device improved the stick-free static longitudinal stability by considerably reducing a stick-force slope reversal which existed in the test airplane at low speeds in the clean, normal rated-power condition.
7. The device did not introduce any undesirable control-free oscillations.
8. The stick-force-per-g investigation confirmed the existing military specifications. The highest gradient tested, 90 pounds per g at 200 miles per hour, was above the limit force per g and was considered to be too heavy. The middle gradient, 60 pounds per g at 200 miles per hour, was not completely within the specified limits and was also

considered by the pilots to be too heavy. The lowest gradient, 30 pounds per g at 200 miles per hour, was within the limits and was considered to be satisfactory.

9. During landings, the combination of booster and feel device afforded much smoother operation of the airplane and, in addition, required less pilot effort.

10. In practice, if the booster is connected to the control surface by cables, cable stretch should be accounted for in the design of the feel device.

11. Satisfactory stick-free stability with a feel device of the type tested depends upon satisfactory stick-fixed stability.

Langley Aeronautical Laboratory
National Advisory Committee for Aeronautics
Langley Field, Va., June 29, 1951

REFERENCE

1. Mathews, Charles W., Talmage, Donald B., and Whitten, James B.: Effects on Longitudinal Stability and Control Characteristics of a B-29 Airplane of Variations in Stick-Force and Control-Rate Characteristics Obtained through Use of a Booster in the Elevator-Control System. NACA TN 2238, 1951.

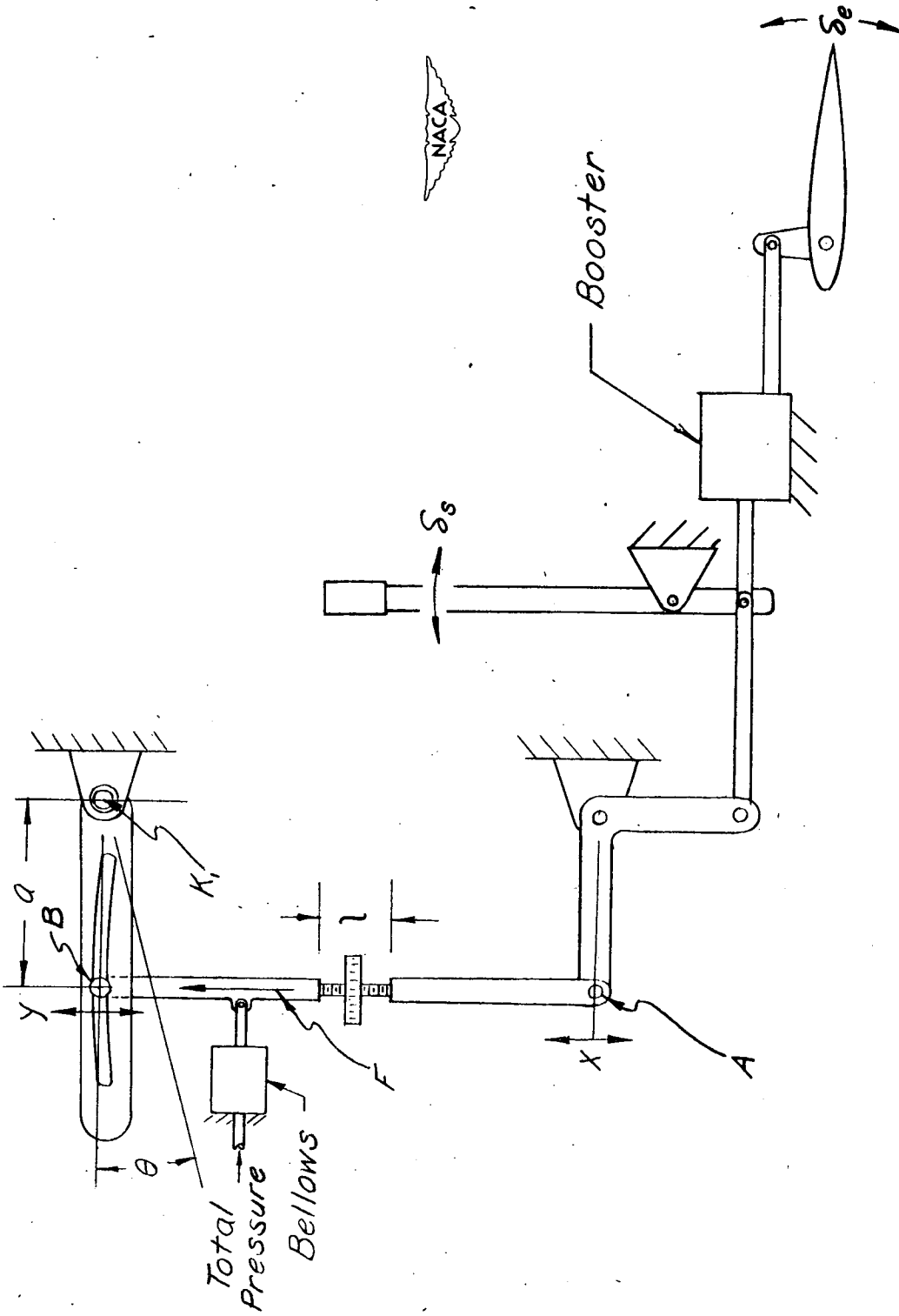
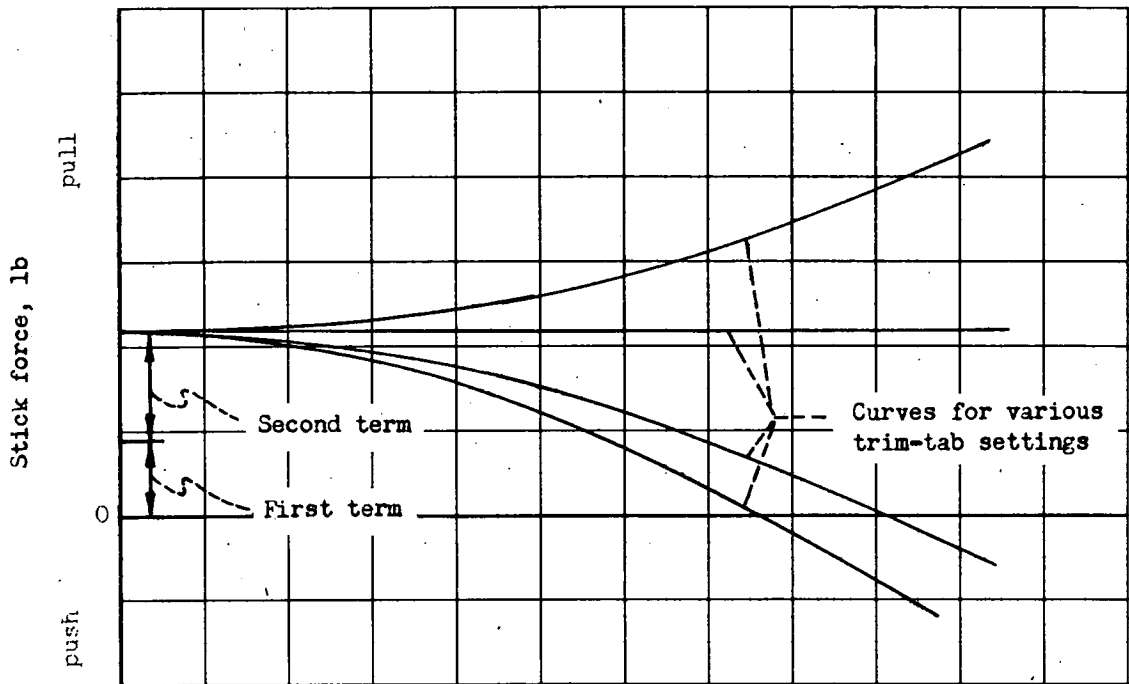
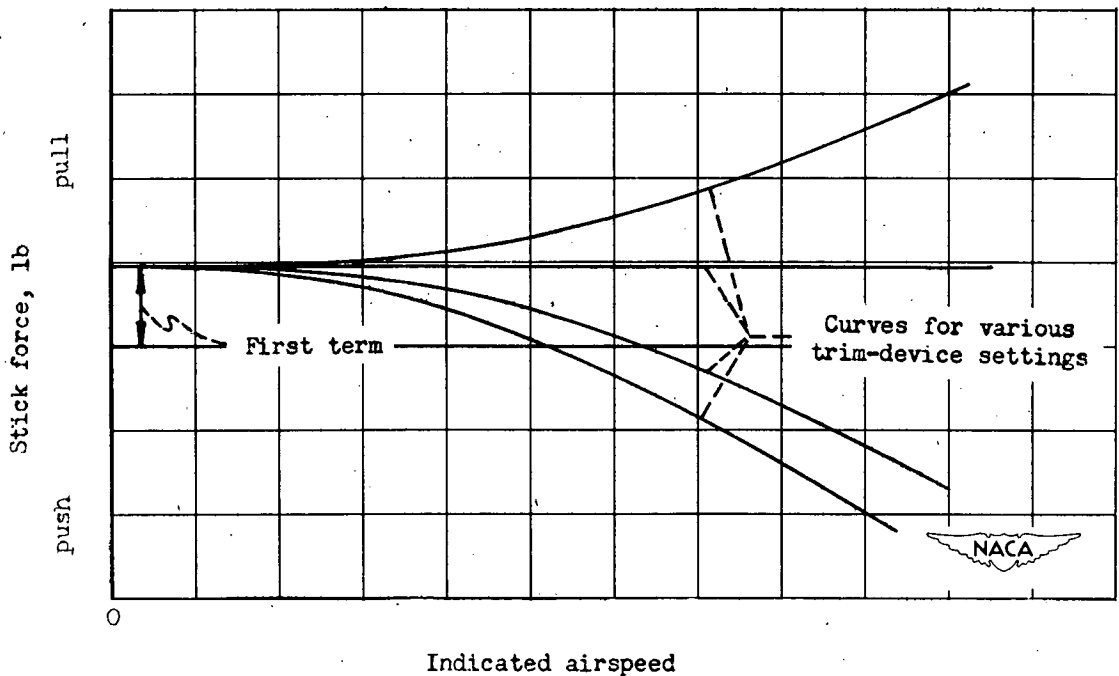

Figure 1.- Schematic drawing of feel device. K_1 is the spring constant of the torsion bar.



(a) Aerodynamic system, equation (3).



(b) Feel device, equation (4).

Figure 2.- Theoretical variation of stick force with airspeed for a conventional aerodynamic control system and a feel-device system.

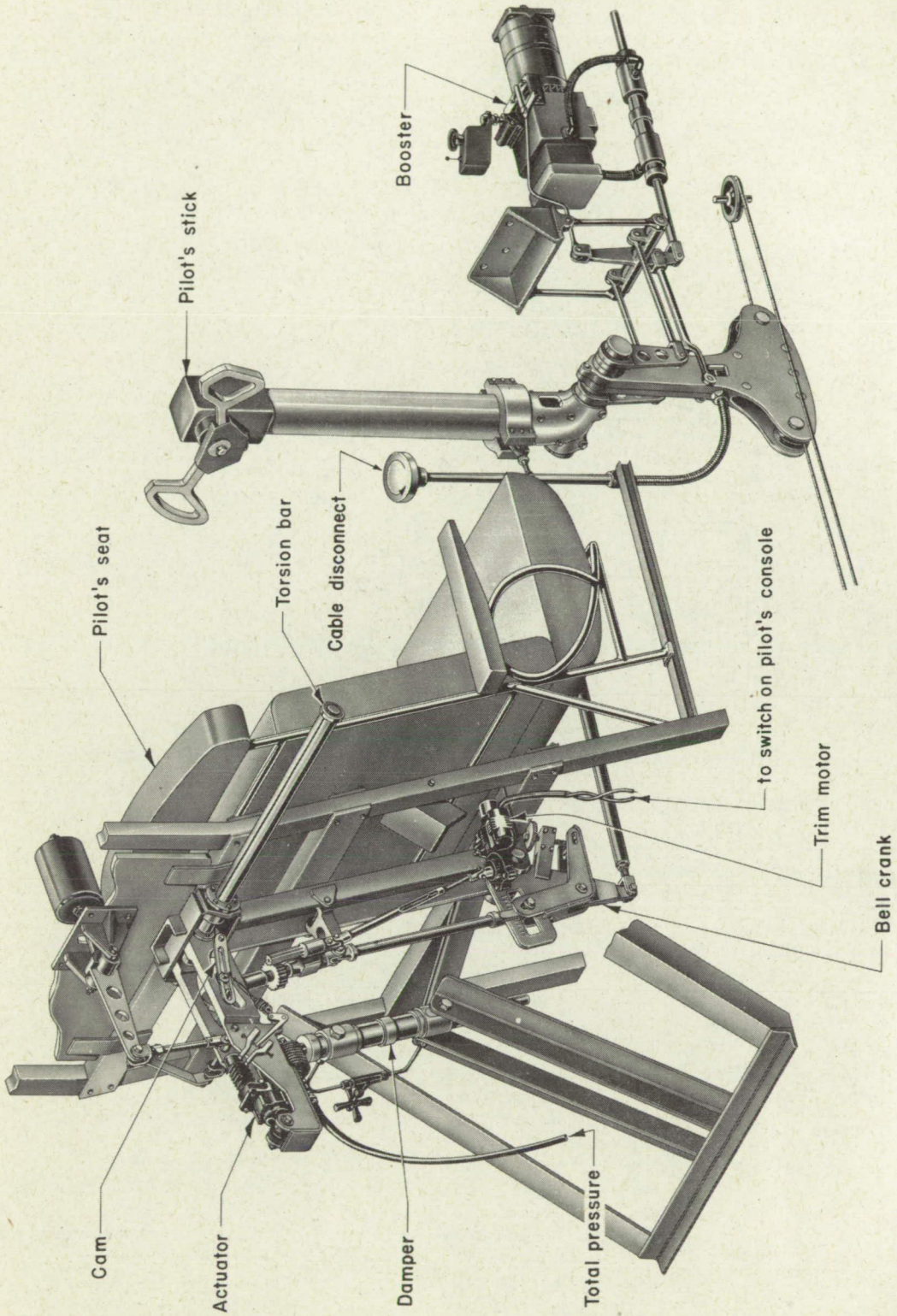

L-70785

Figure 3.- Drawing showing relative arrangement of feel device and booster in test airplane.

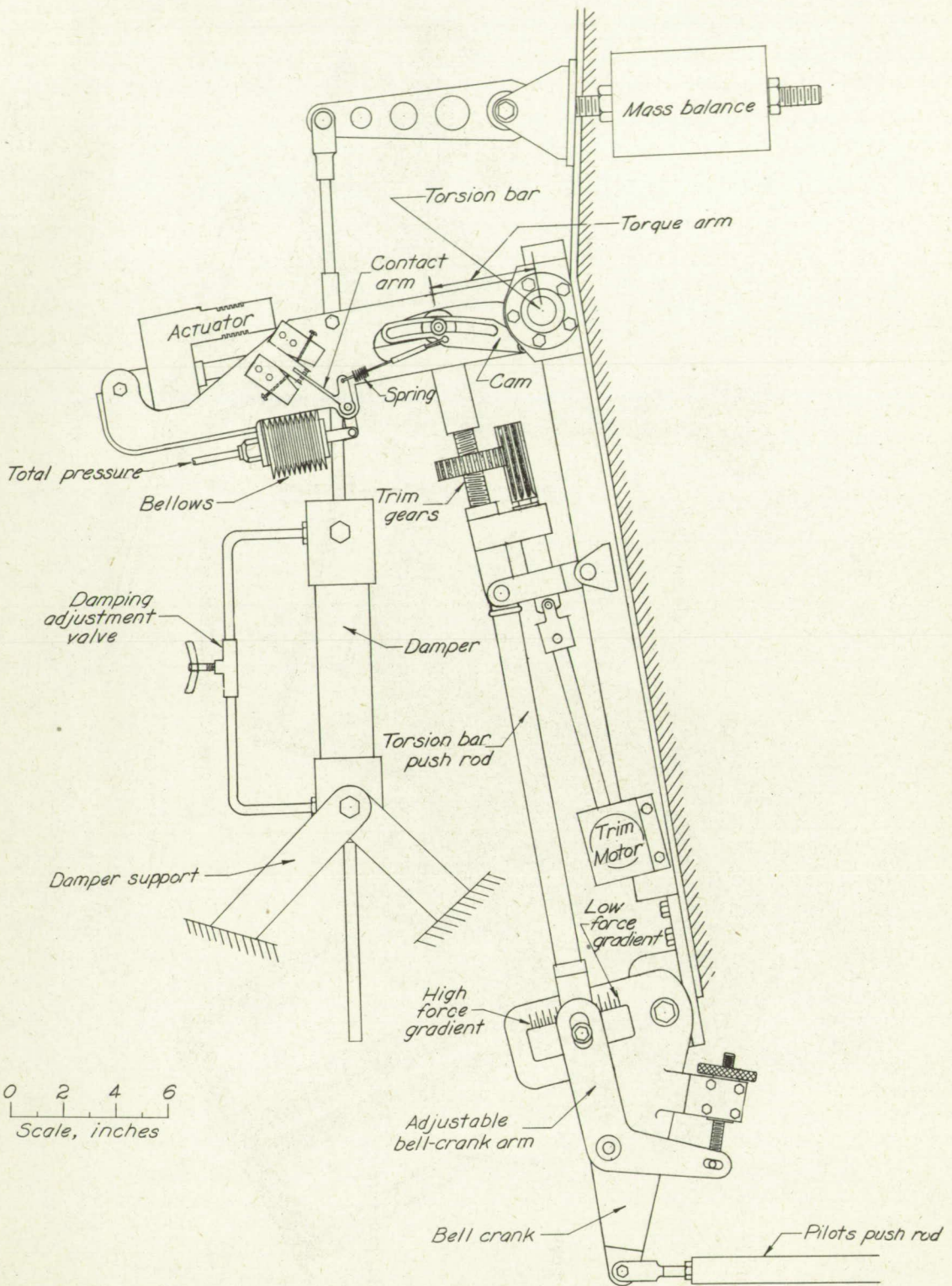

Figure 4.- Scale drawing of feel device.



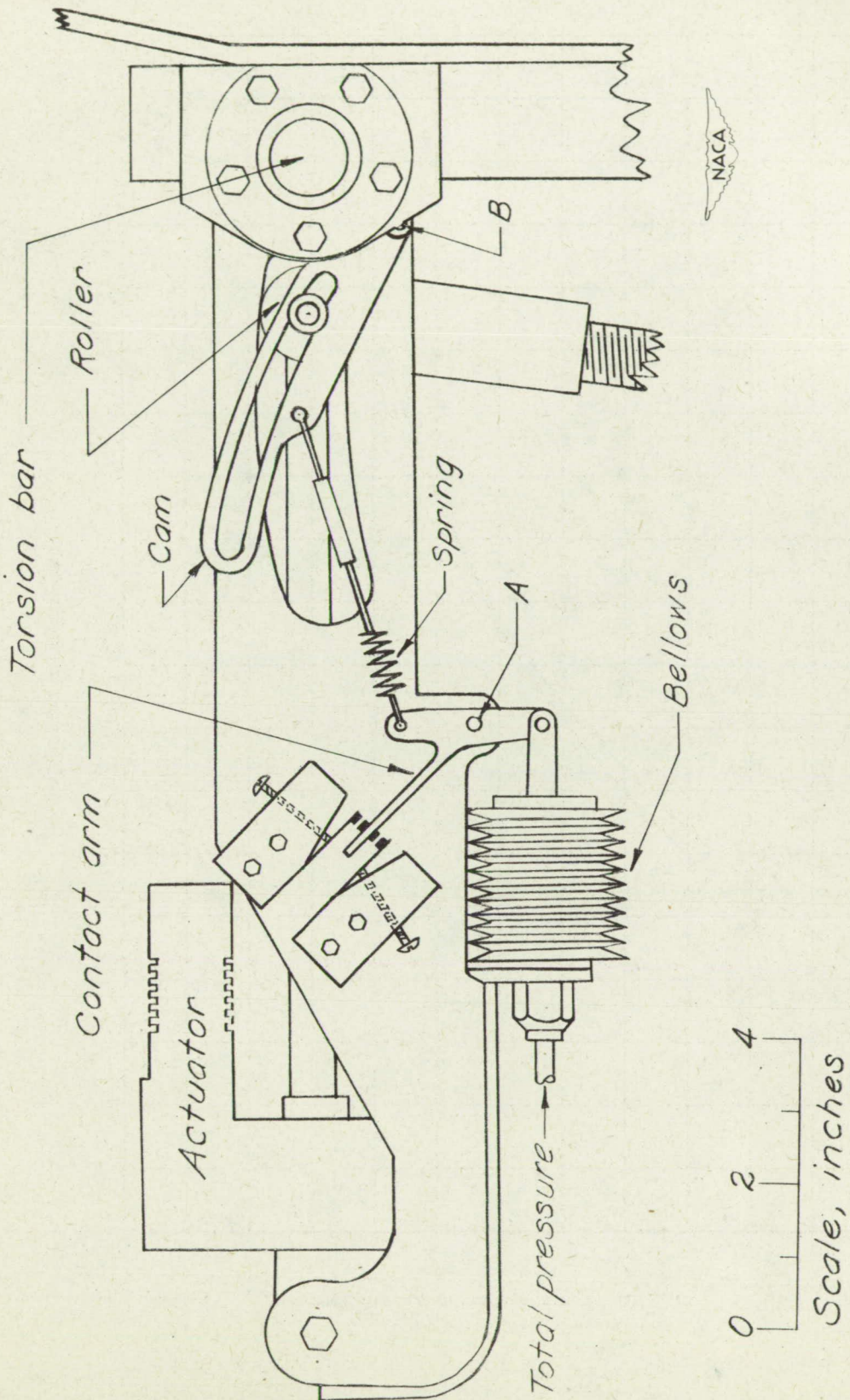

Figure 5.- Drawing showing components in airspeed sensing system.

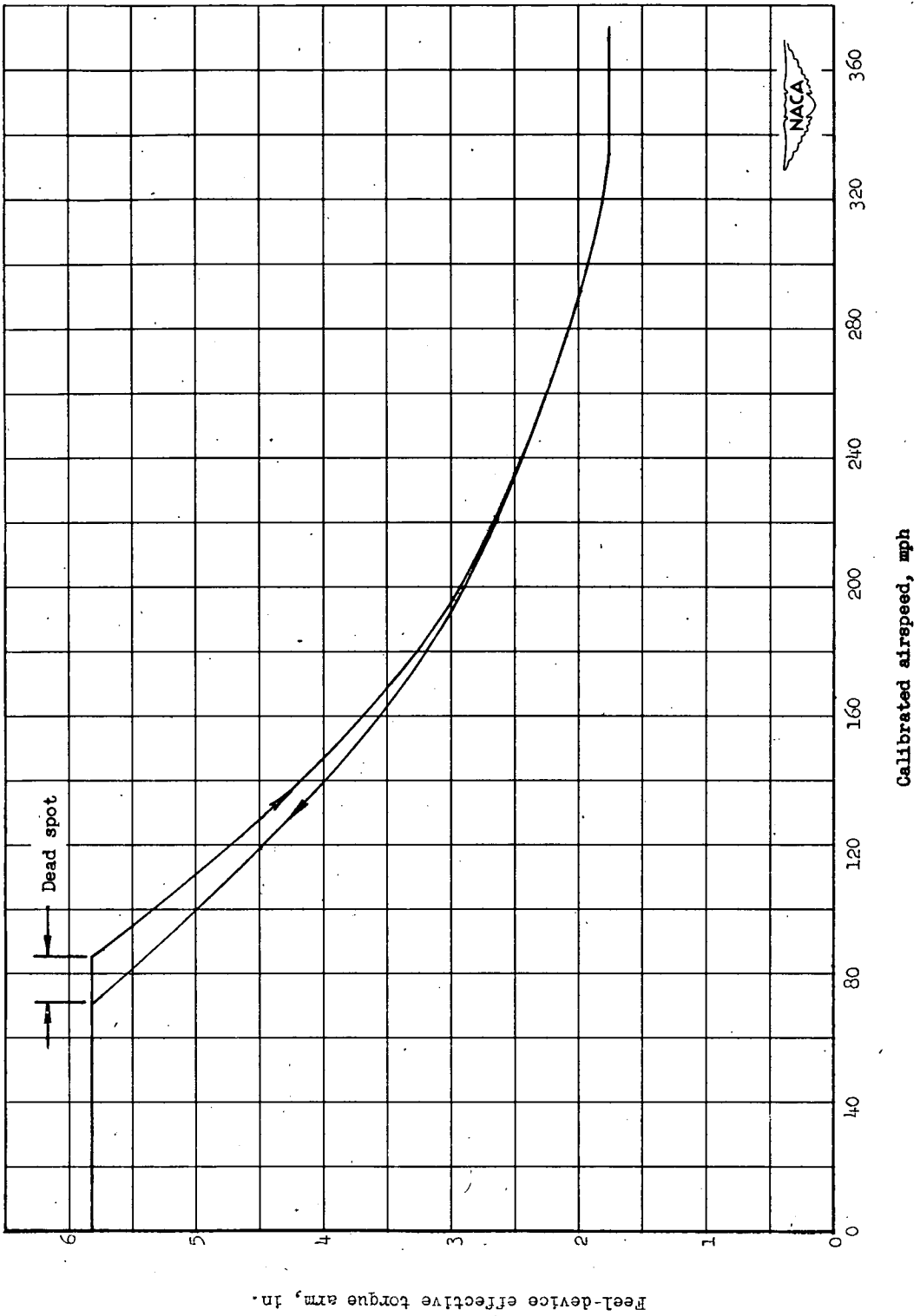

Figure 6.- Ground calibration showing variation of torque-arm length with airspeed.

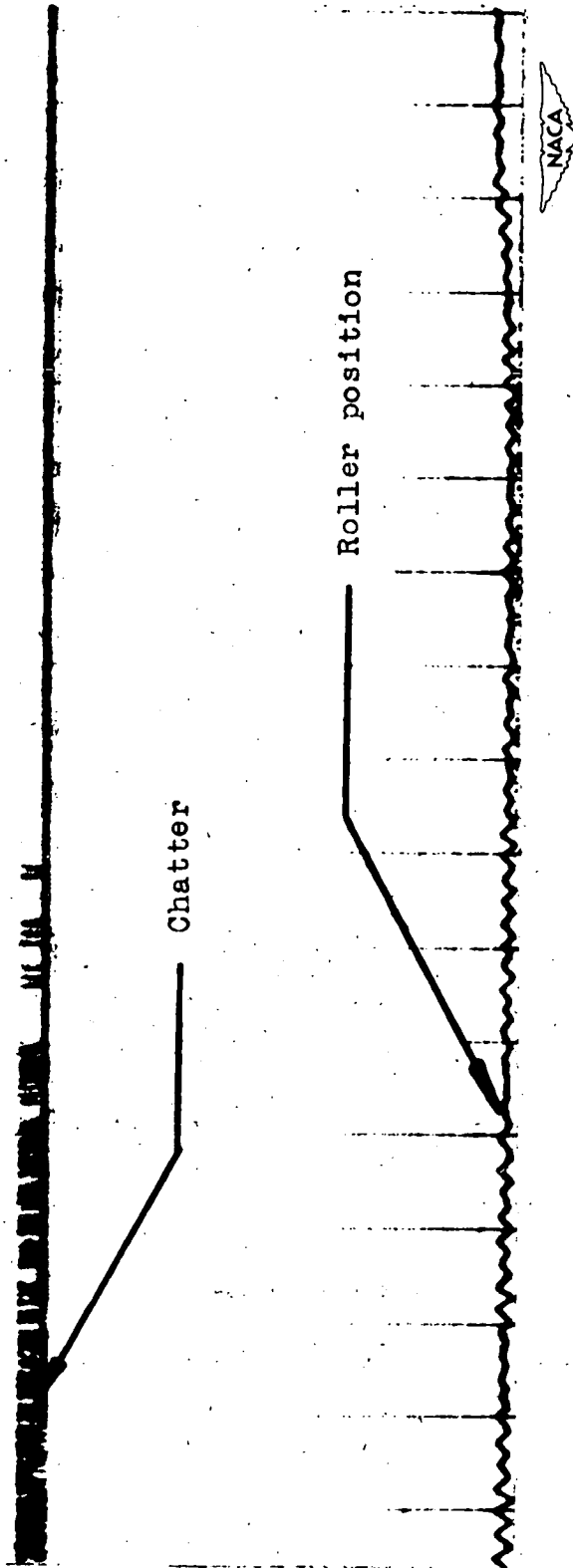

Figure 7.- Flight record showing behavior of contact arm and roller during typical test run.

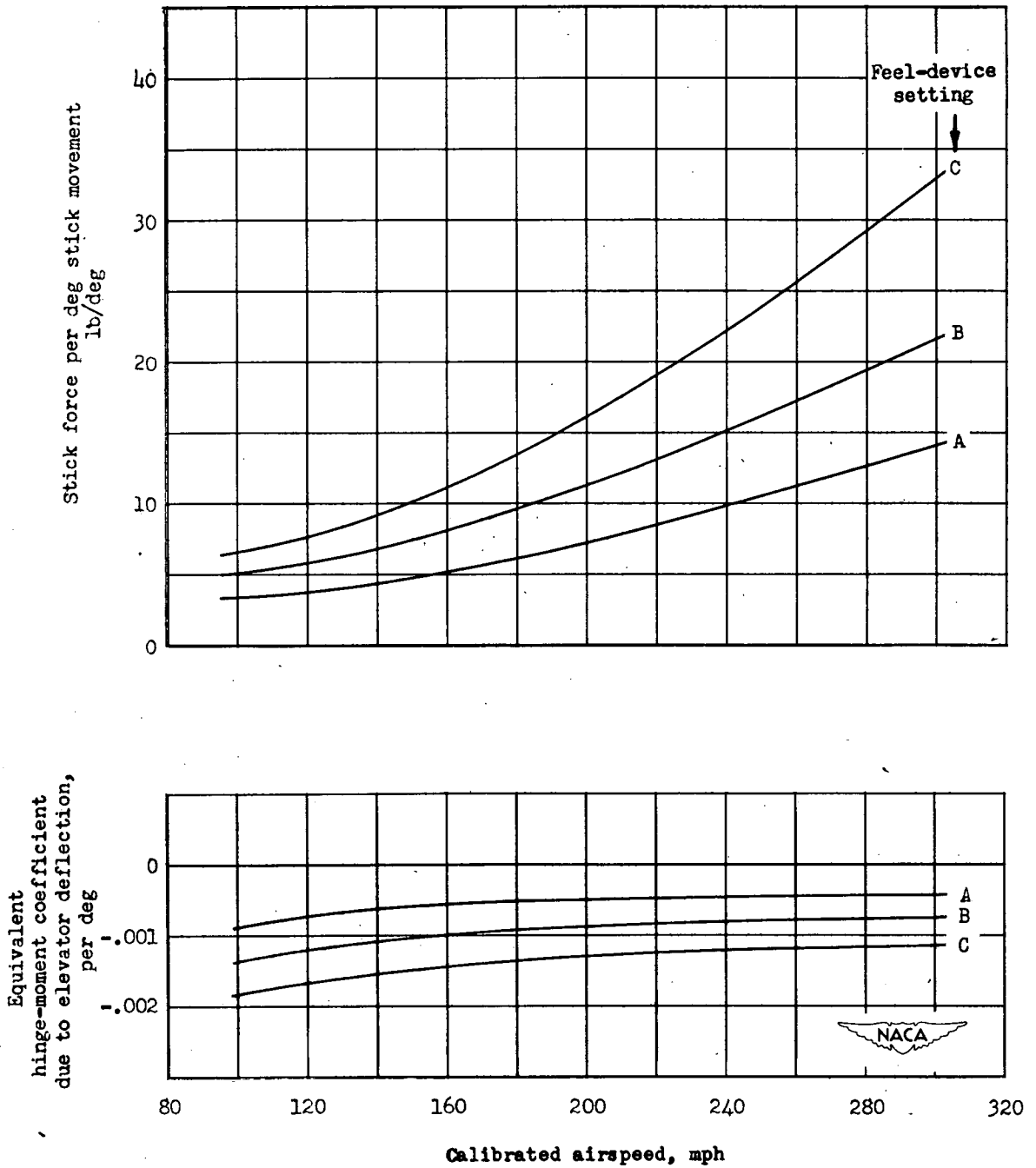

Figure 8.- Ground calibration of feel device.

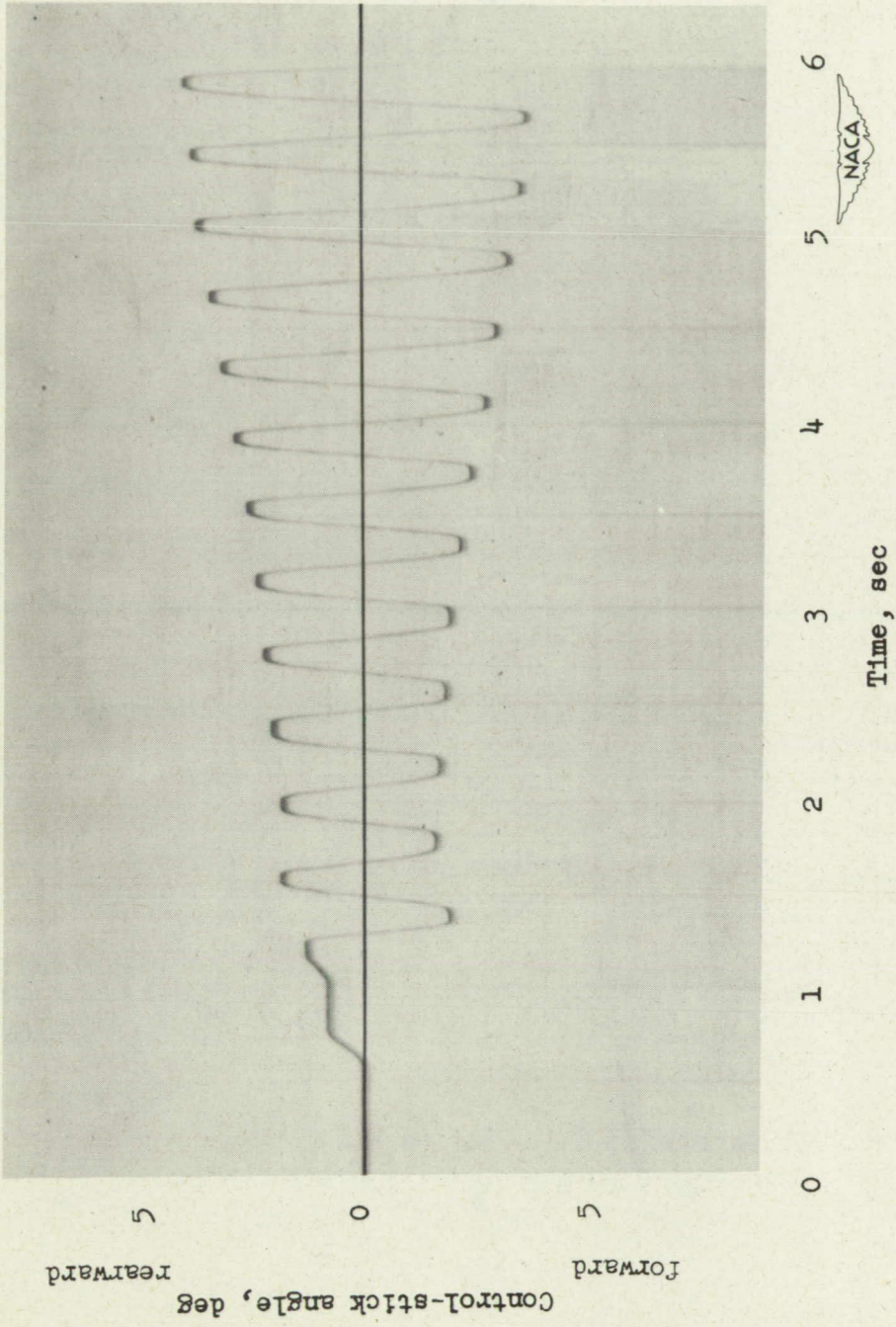

Figure 9.- Ground time history showing oscillation in control stick resulting from infinite boost ratio.

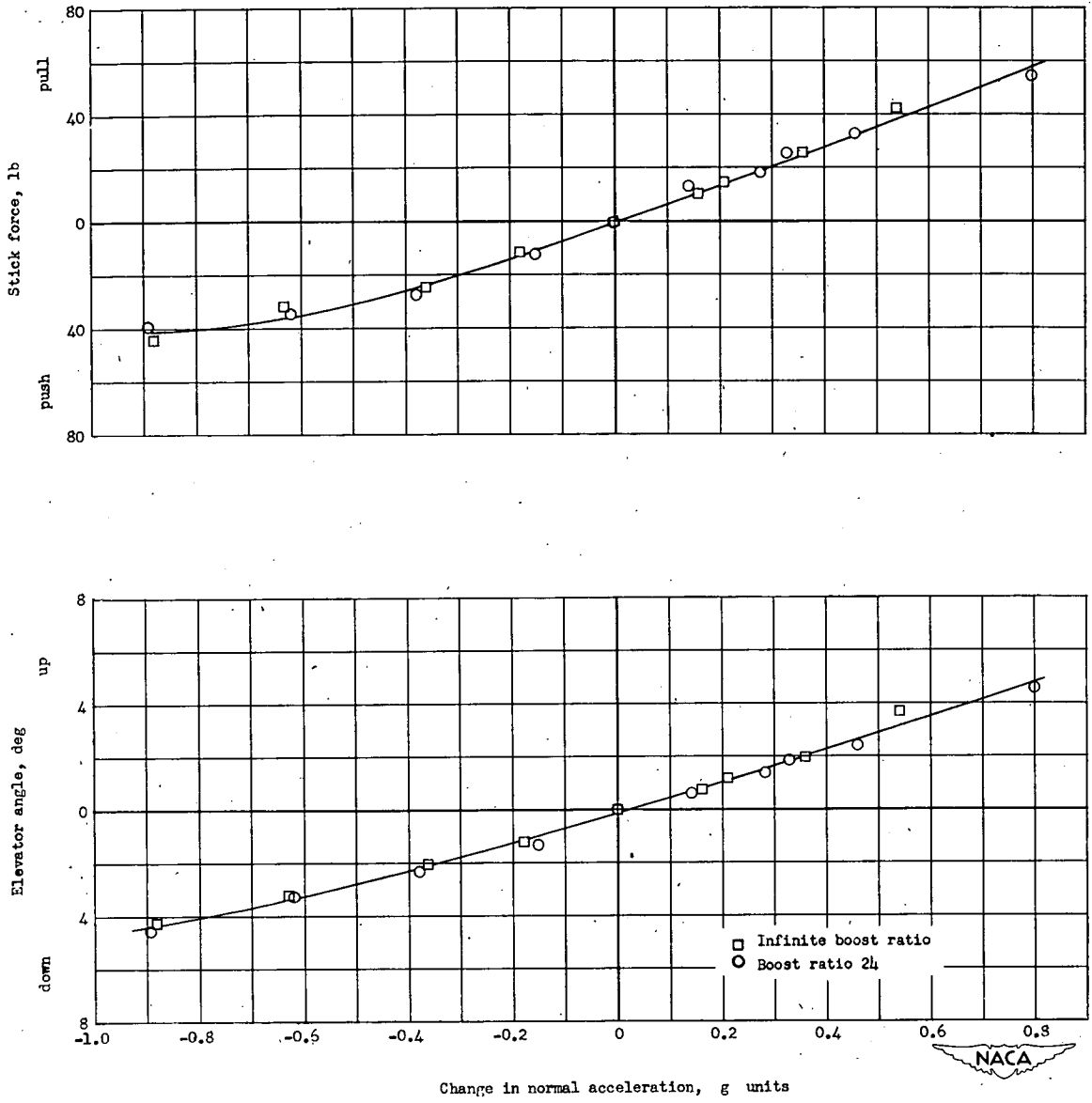
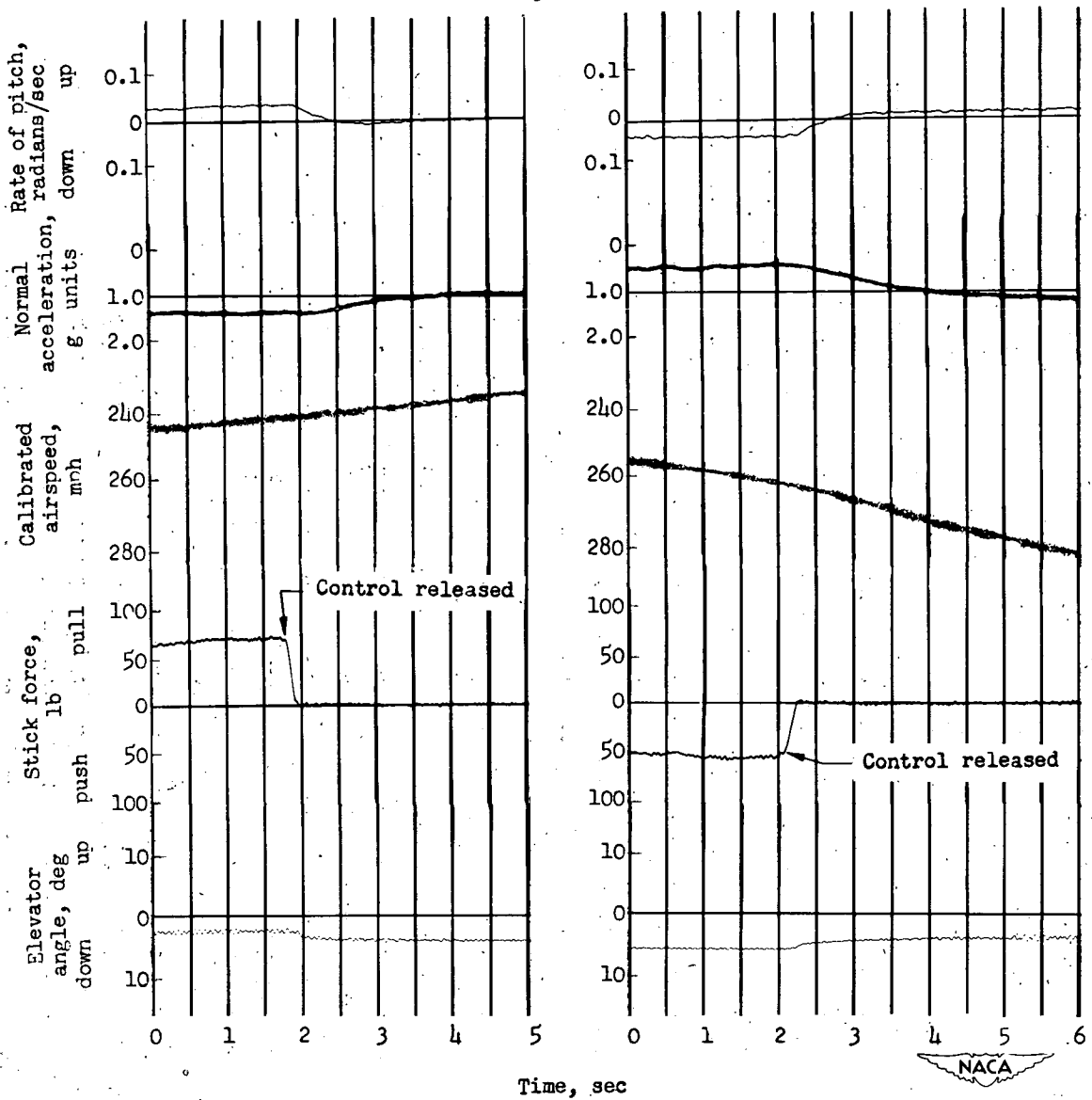
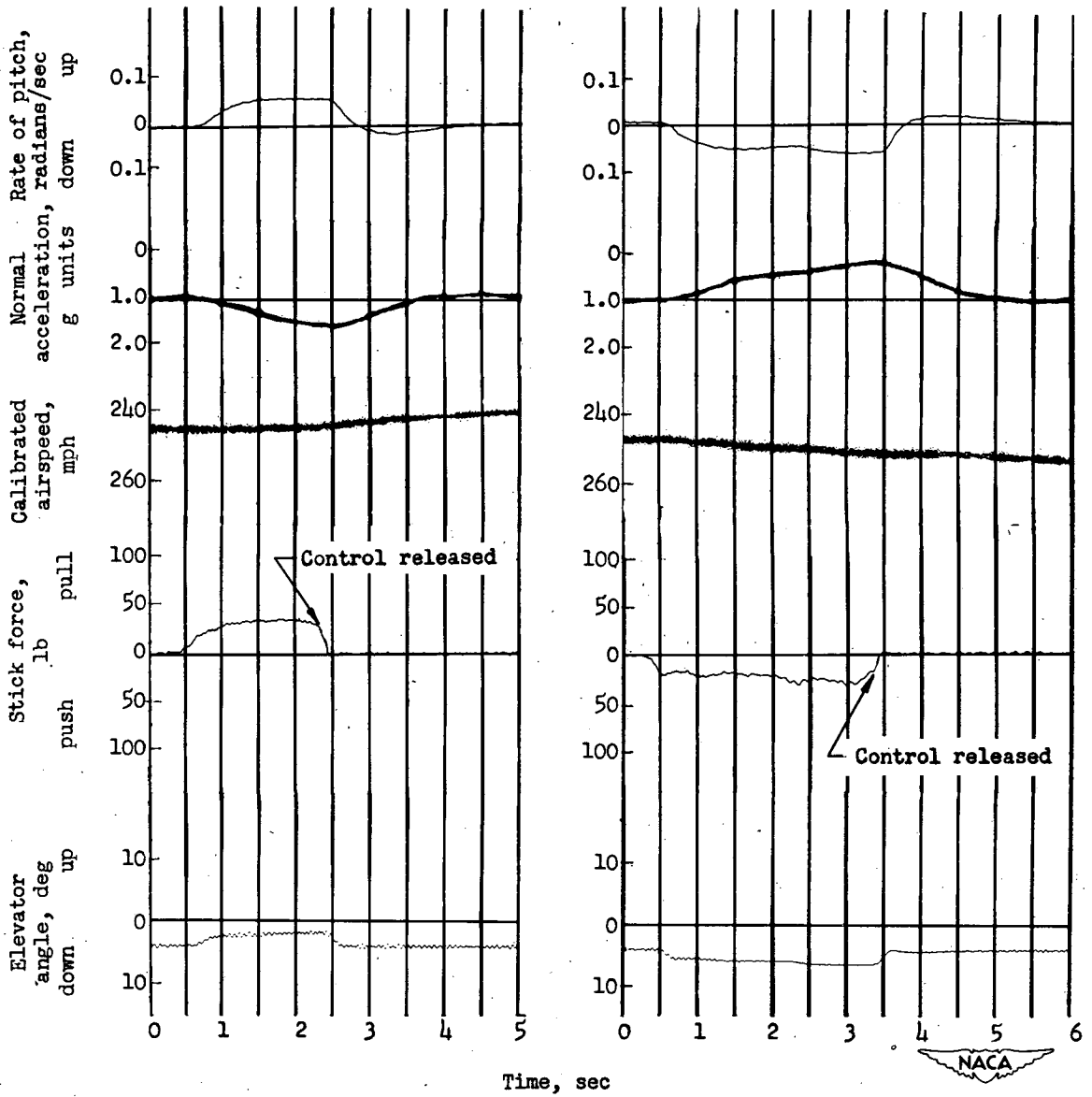

Figure 10.- Comparison of stick forces and elevator angles for boost ratio 24 and infinite boost ratio.



(a) Airplane without feel device.

Figure 11.- Time histories of dynamic longitudinal stability runs. Pull-ups and push-downs, each followed by release of the control stick, are shown. Clean condition, normal rated power; airspeed, 250 miles per hour.



(b) Feel-device setting A.

Figure 11.- Continued.



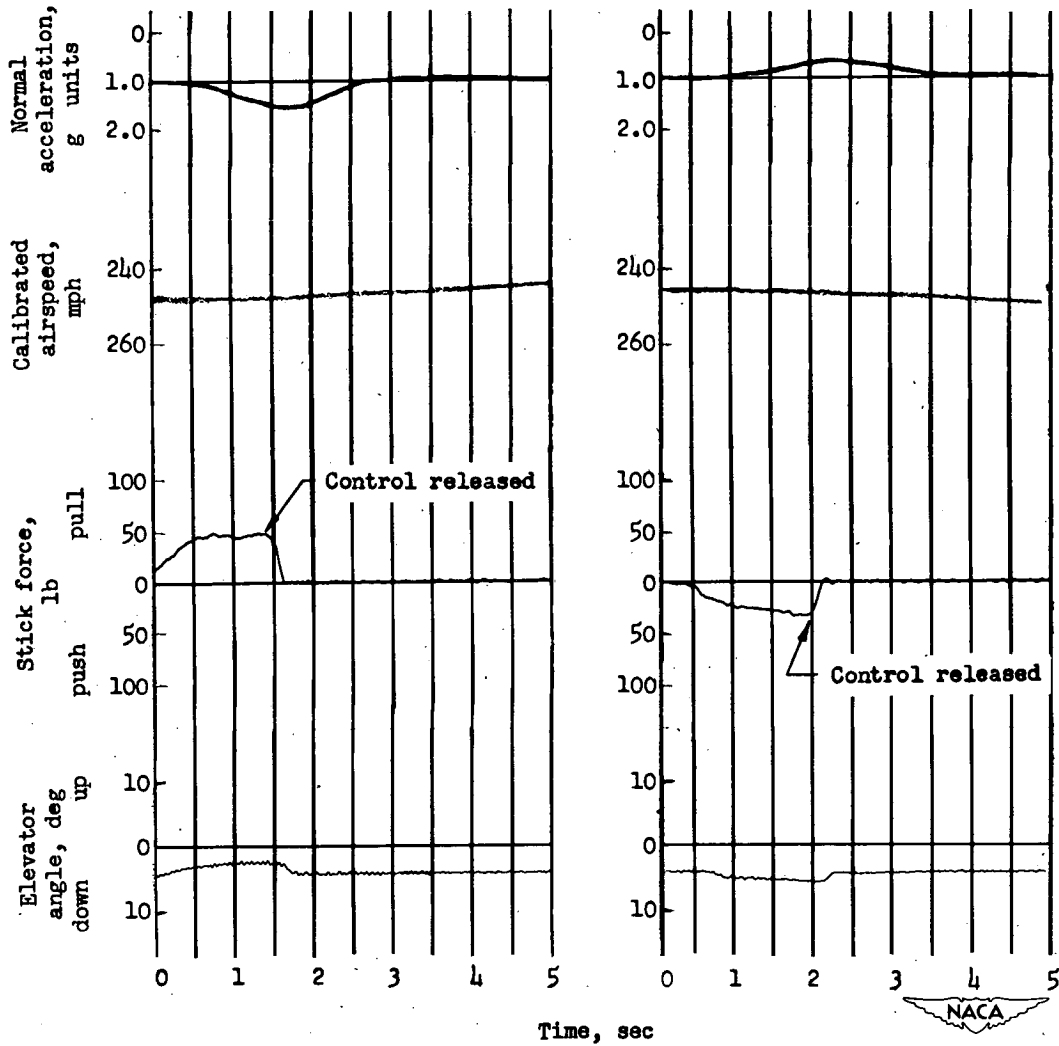

(c) Feel-device setting B.

Figure 11.- Continued.

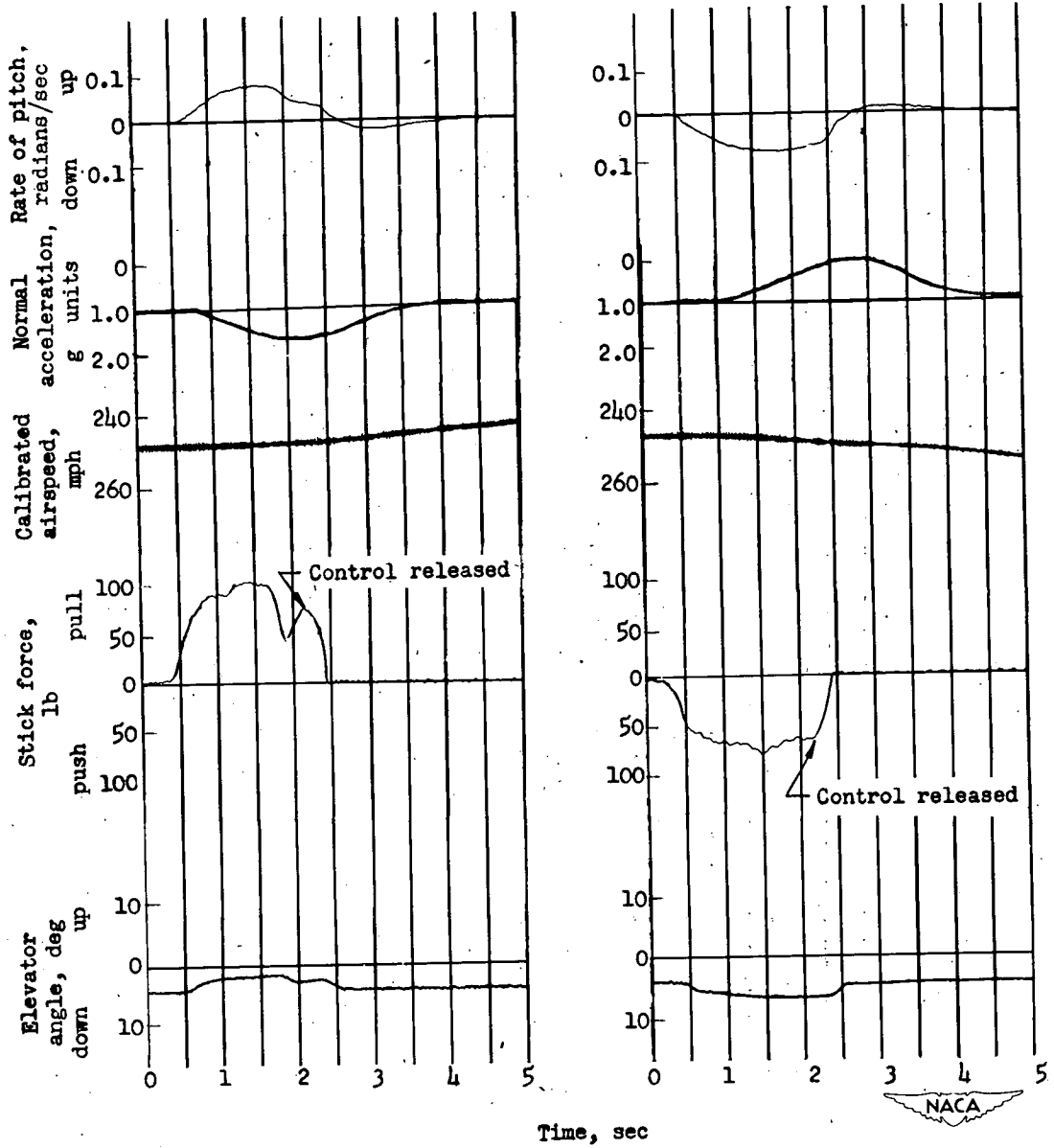

(d) Feel-device setting C.

Figure 11.- Concluded.

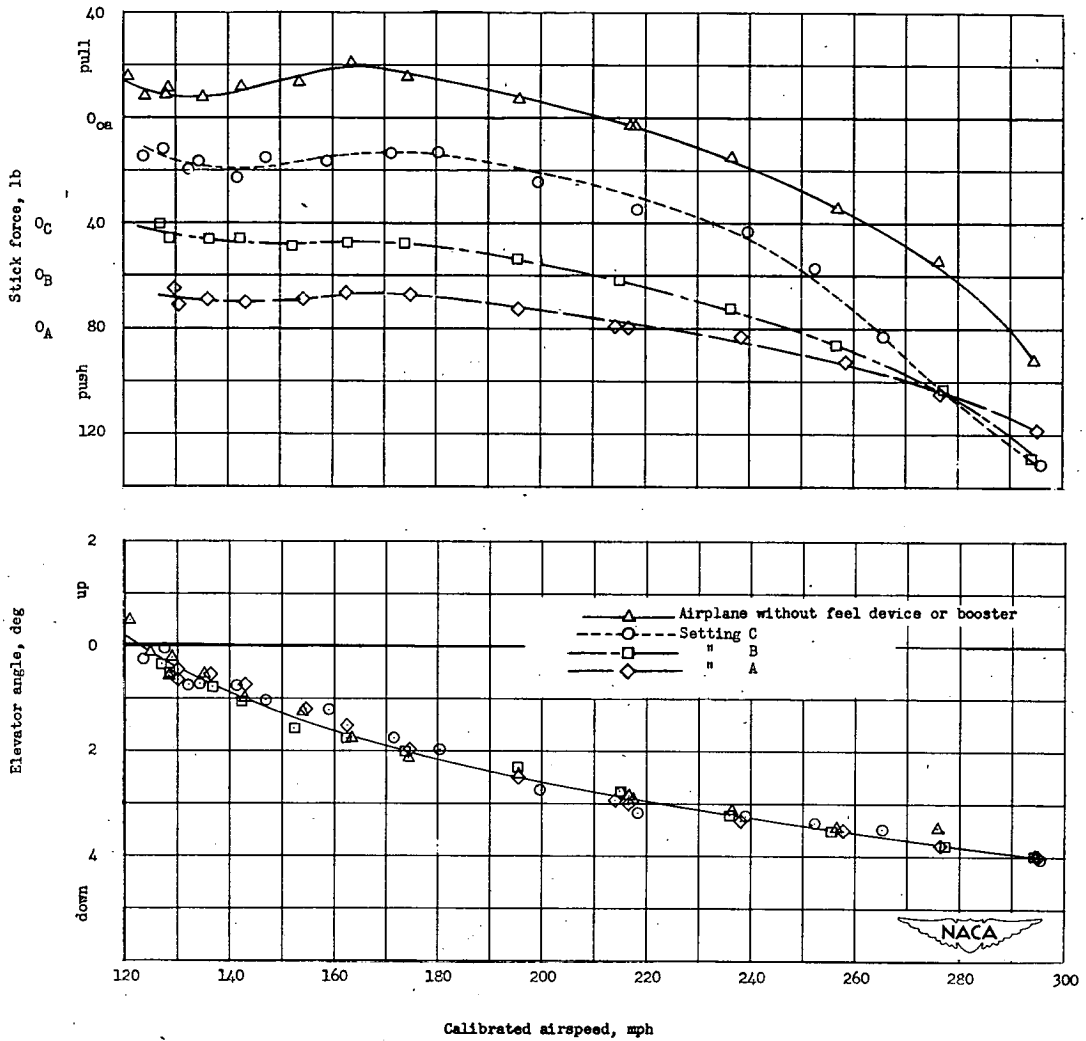

(a) Variation of stick force and elevator angle with indicated airspeed.

Figure 12.- Effect of feel device on the static longitudinal stability for the clean condition, normal rated power.

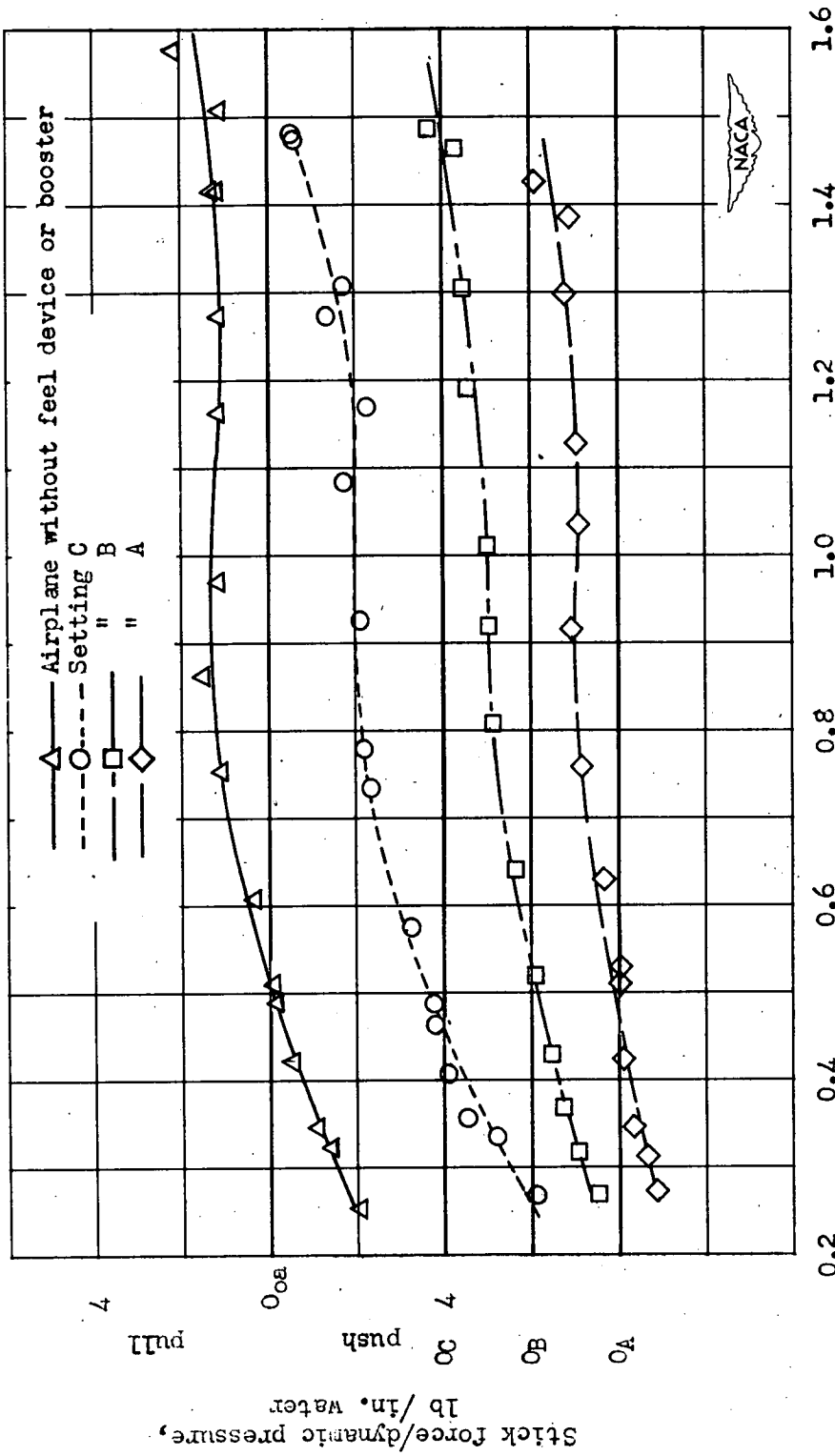

(b) Variation of stick force divided by dynamic pressure with normal-force coefficient.

Figure 12.- Concluded.

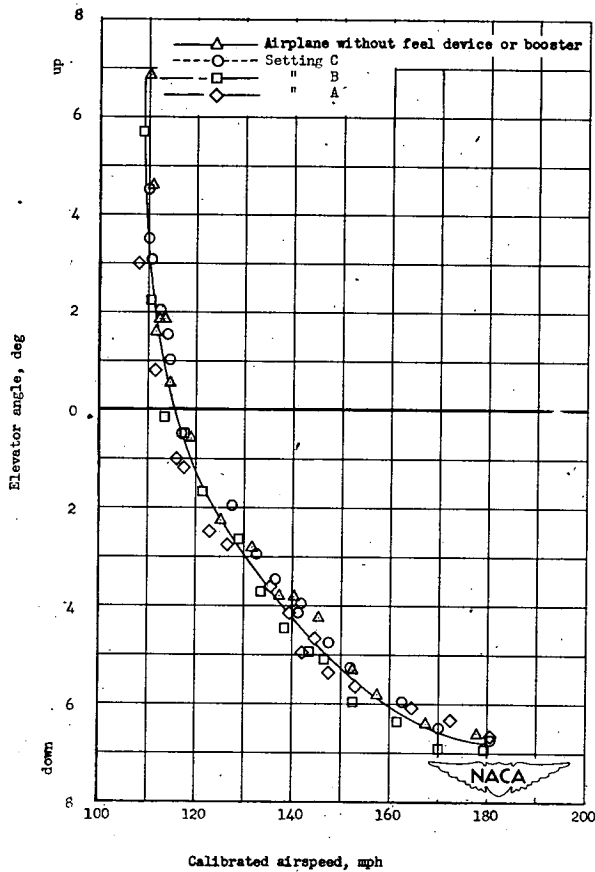
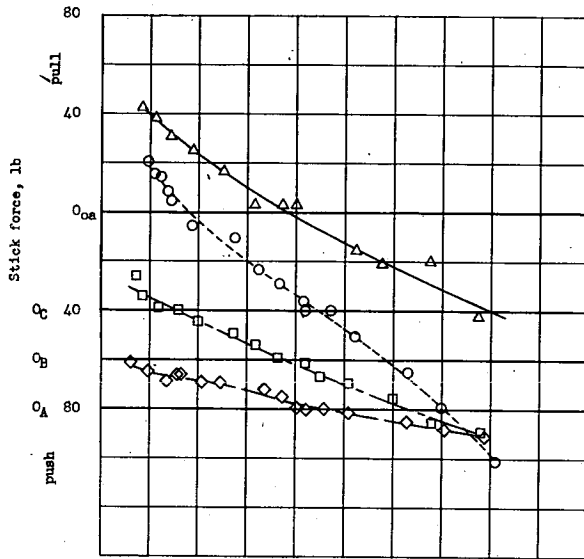

(a) Variation of stick force and elevator angle with indicated airspeed.

Figure 13.- Effect of feel device on the static longitudinal stability for the landing condition. (Flaps and gear down.)

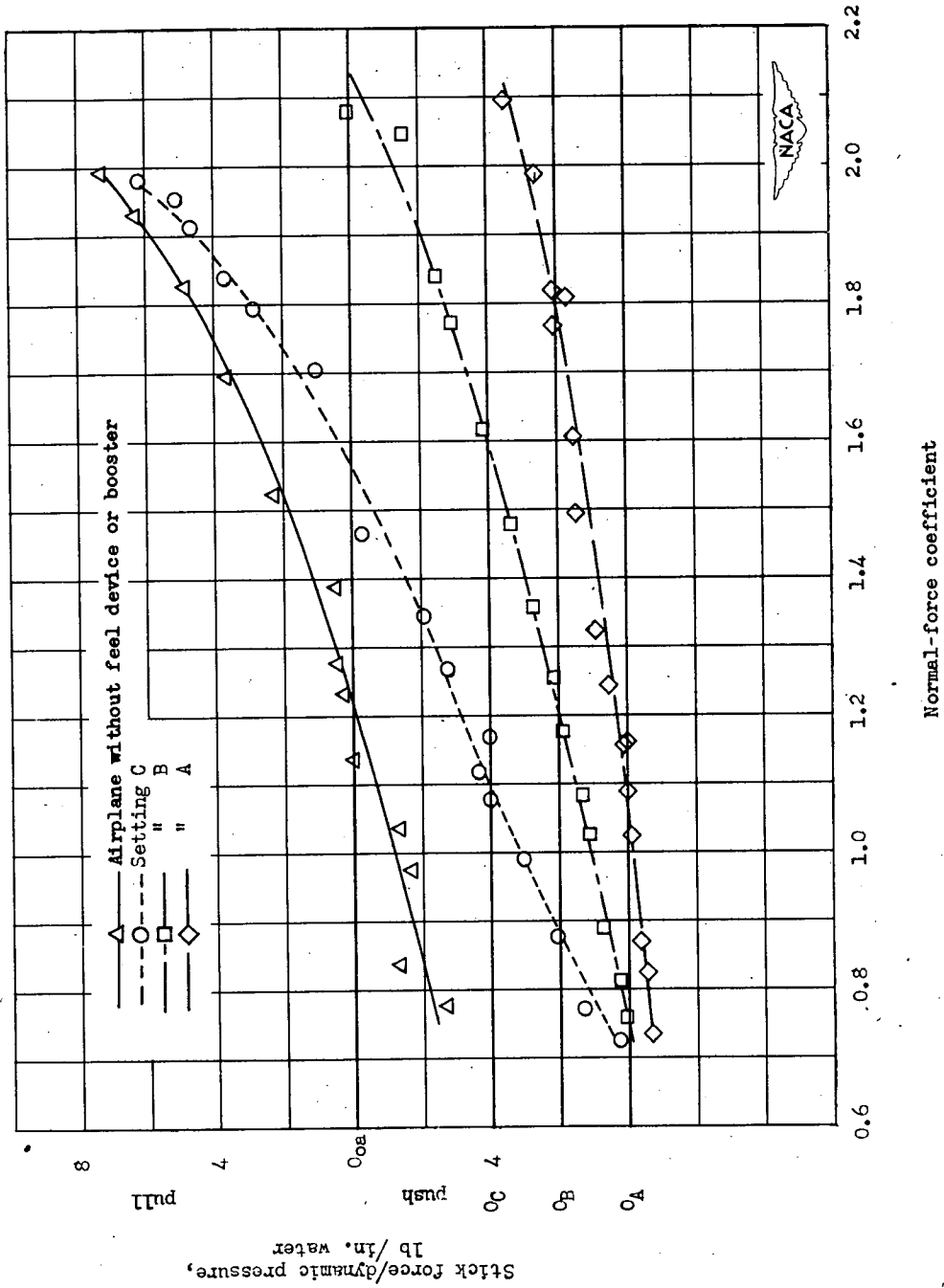

(b) Variation of stick force divided by dynamic pressure with normal force coefficient.

Figure 13.- Concluded.

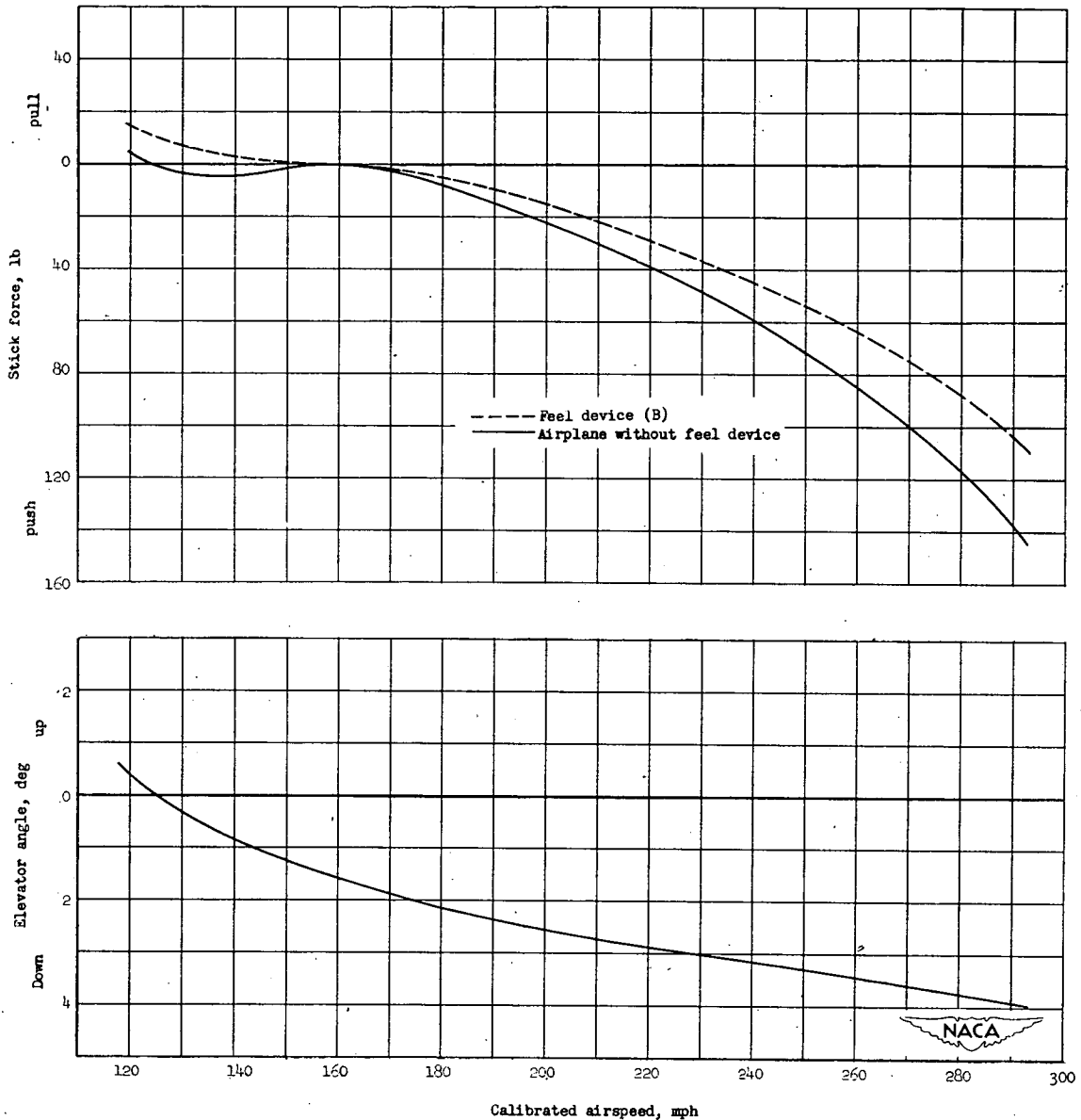

Figure 14.- Calculated static longitudinal stability in the clean, normal rated-power condition. Trim speed, 160 miles per hour.

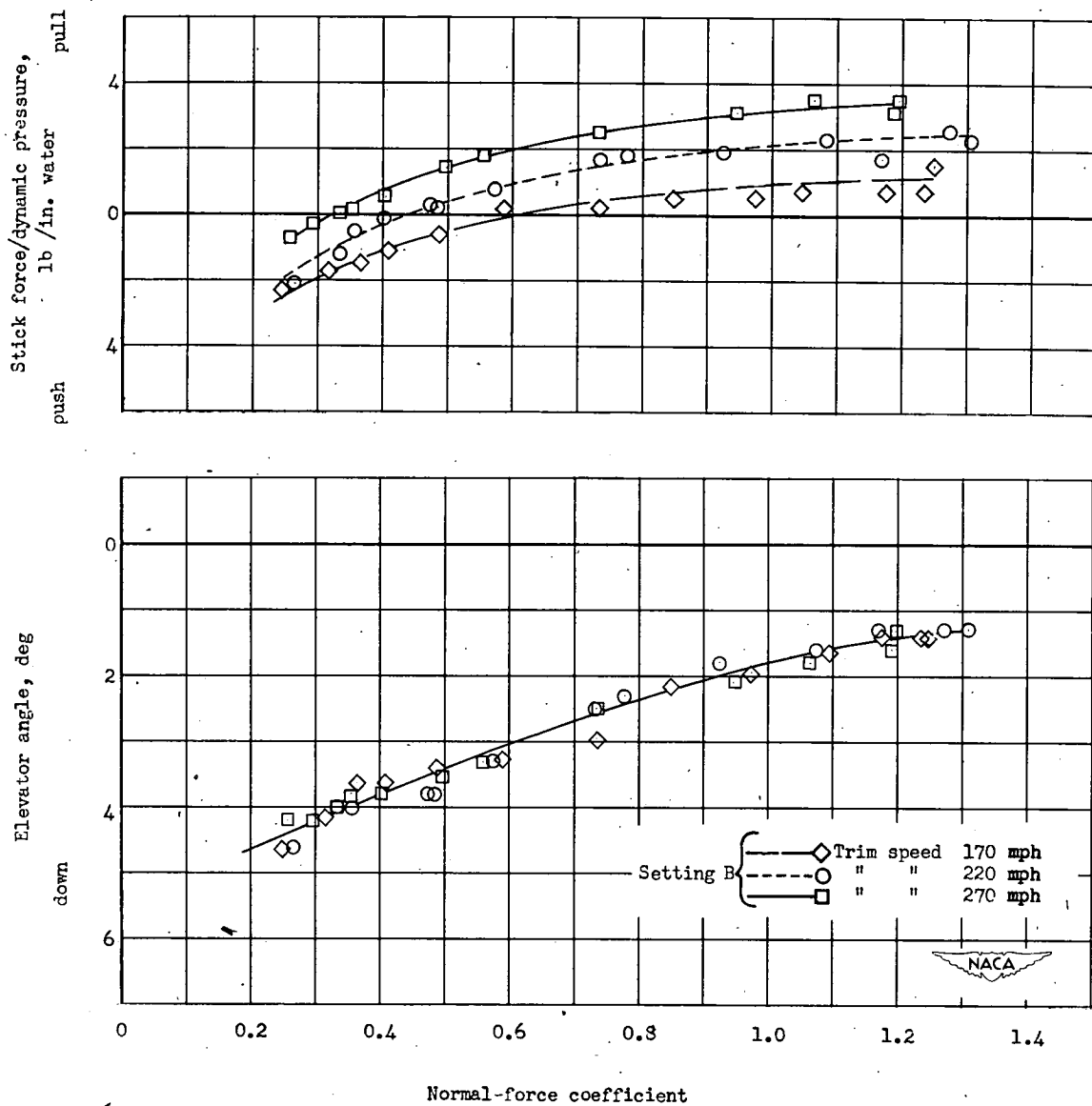
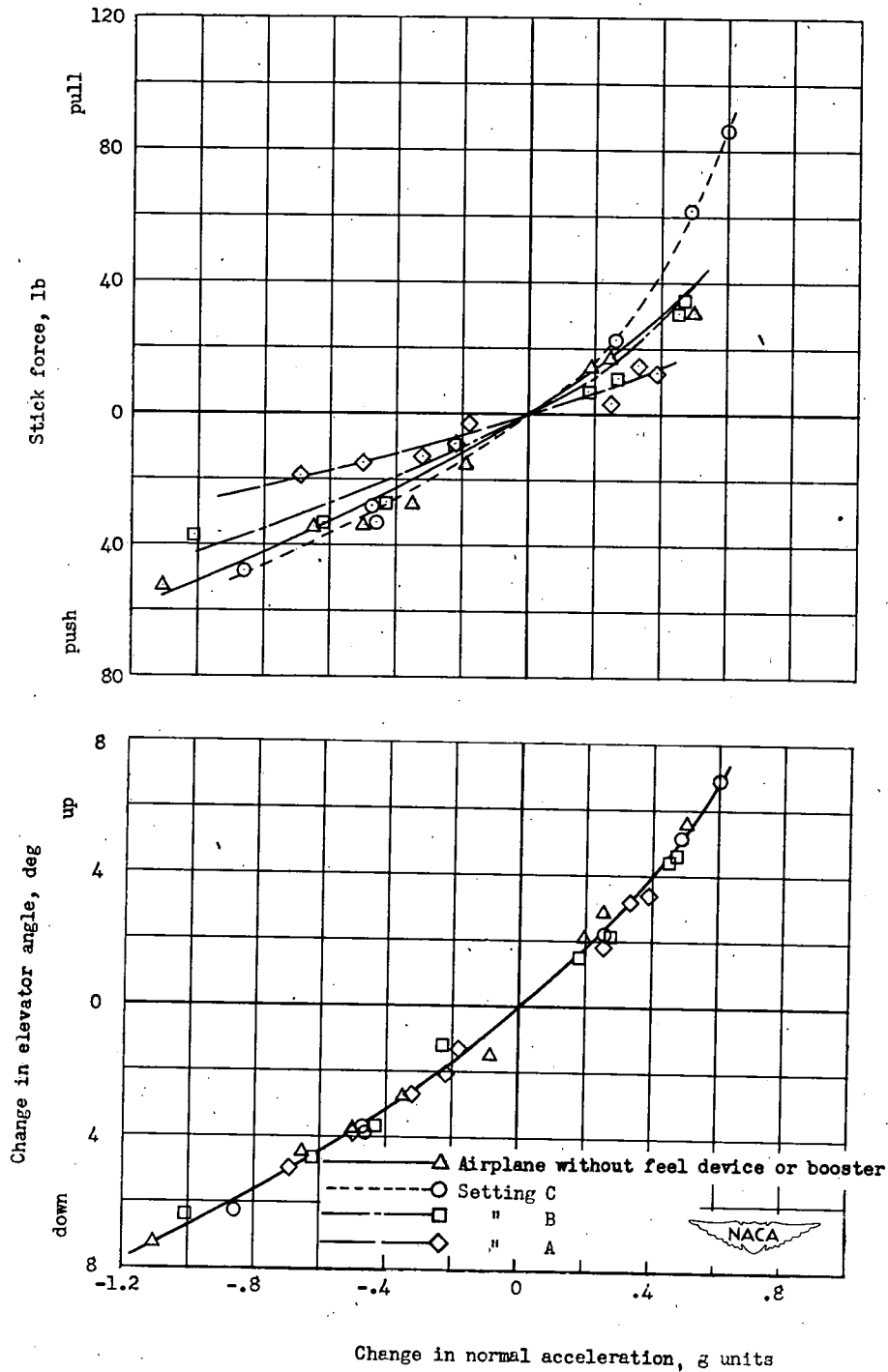
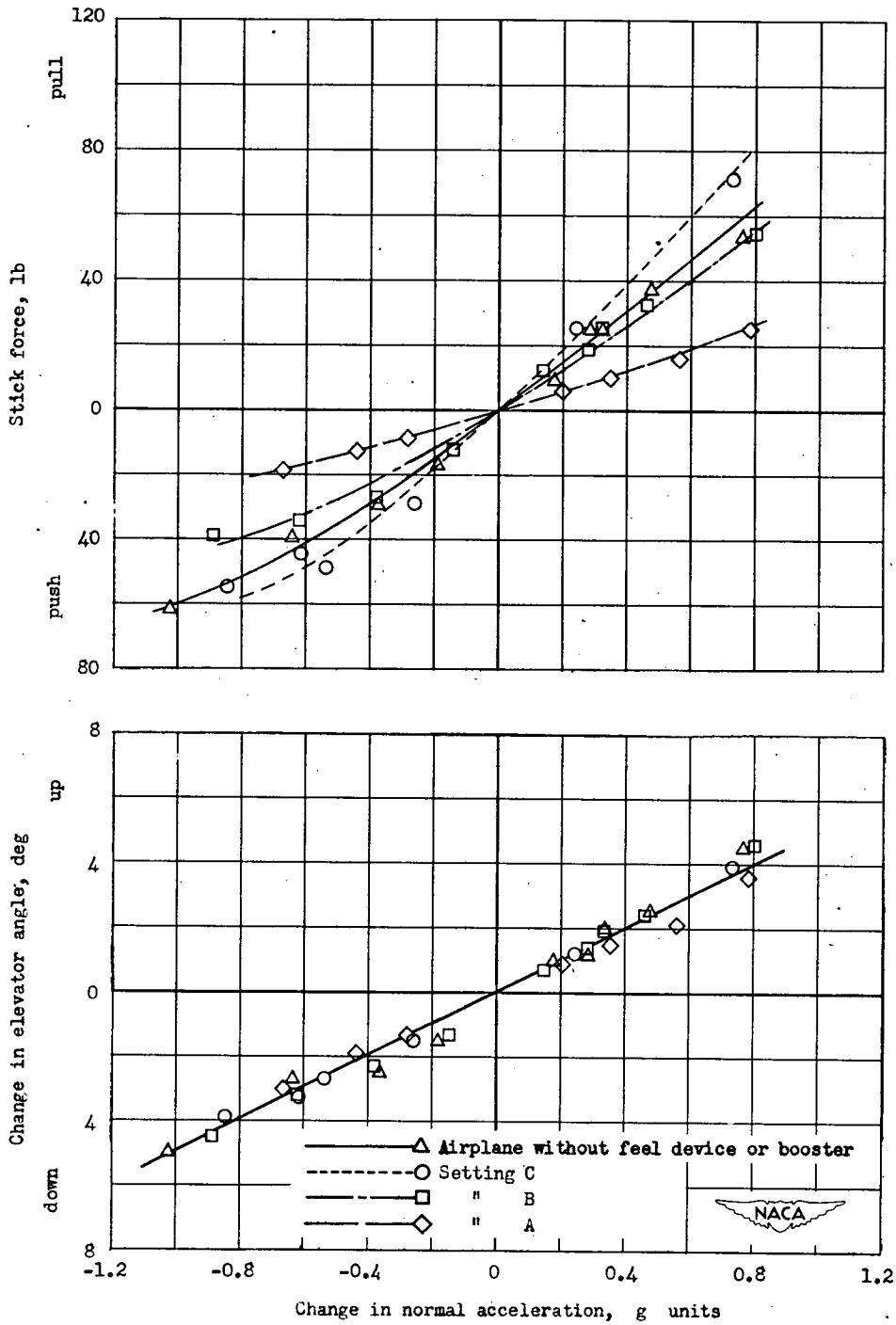

Figure 15.- Trim characteristics of the feel device.



(a) Indicated airspeed, 160 miles per hour.

Figure 16.- Effect of feel device on variation of elevator control force with normal acceleration as measured in pull-ups and push-downs. Clean condition, normal rated power.



(b) Indicated airspeed, 200 miles per hour.

Figure 16.- Continued.

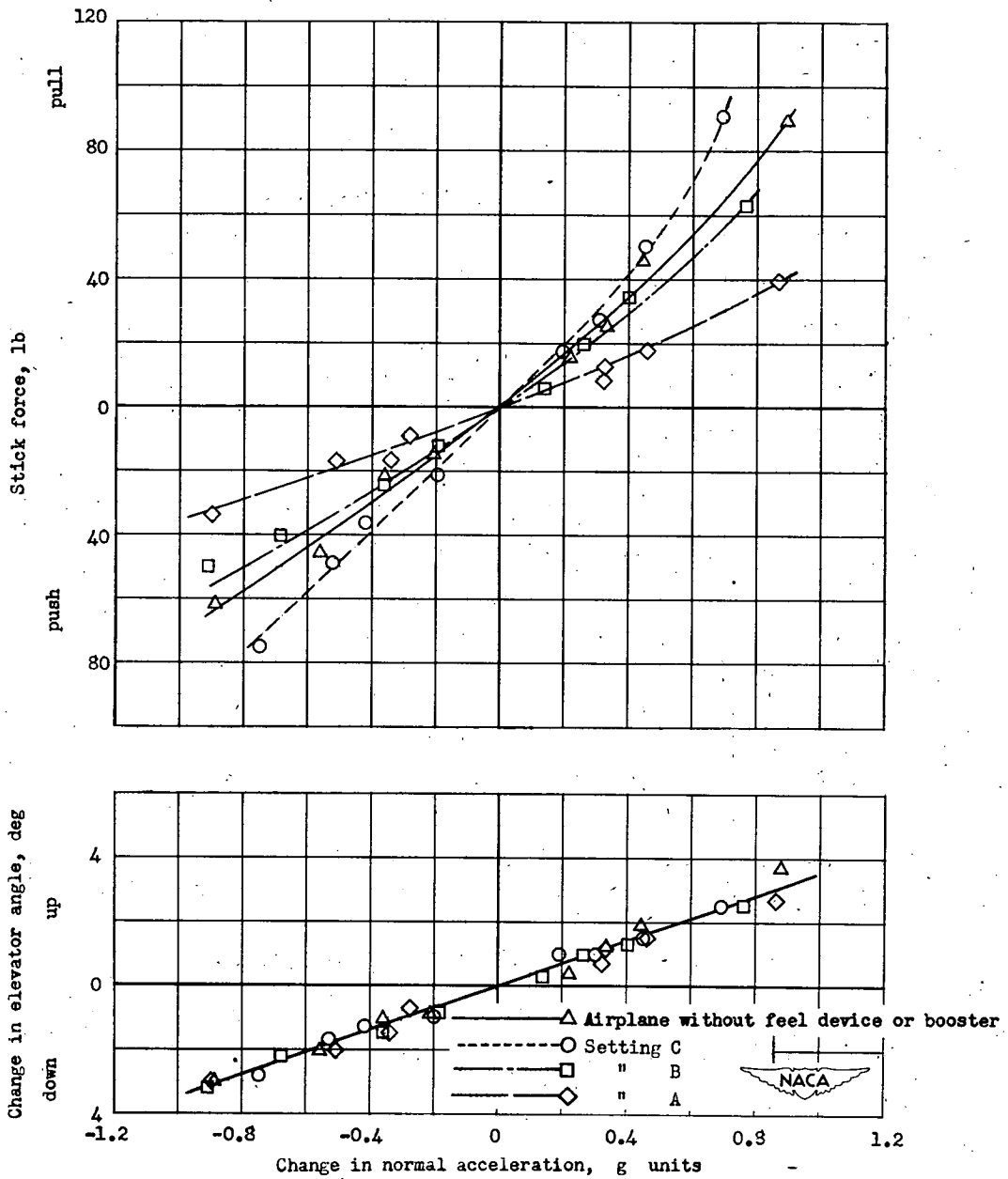

(c) Indicated airspeed, 250 miles per hour.

Figure 16.- Concluded.

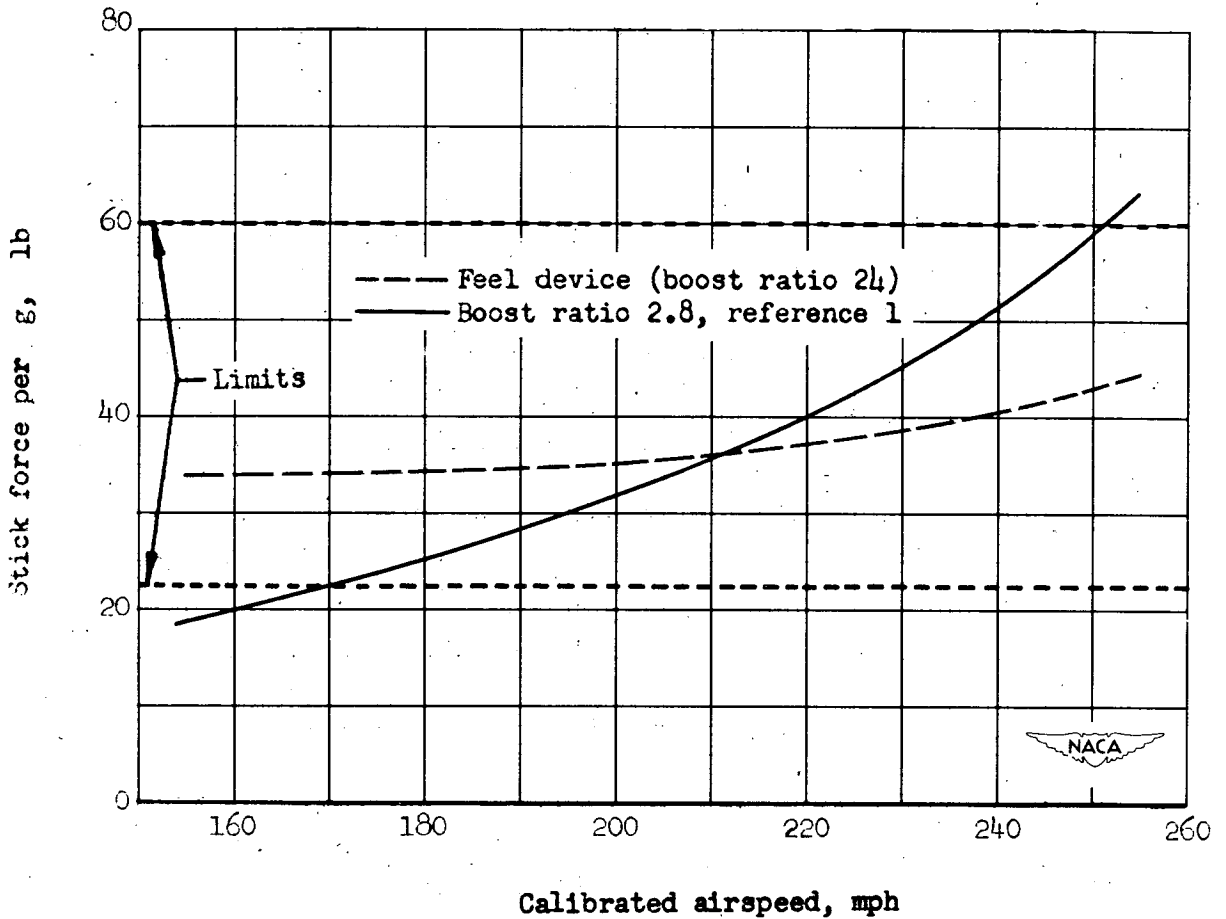

Figure 17.- Comparison of boost-ratio-2.8 condition to feel-device setting A (with boost ratio 24).

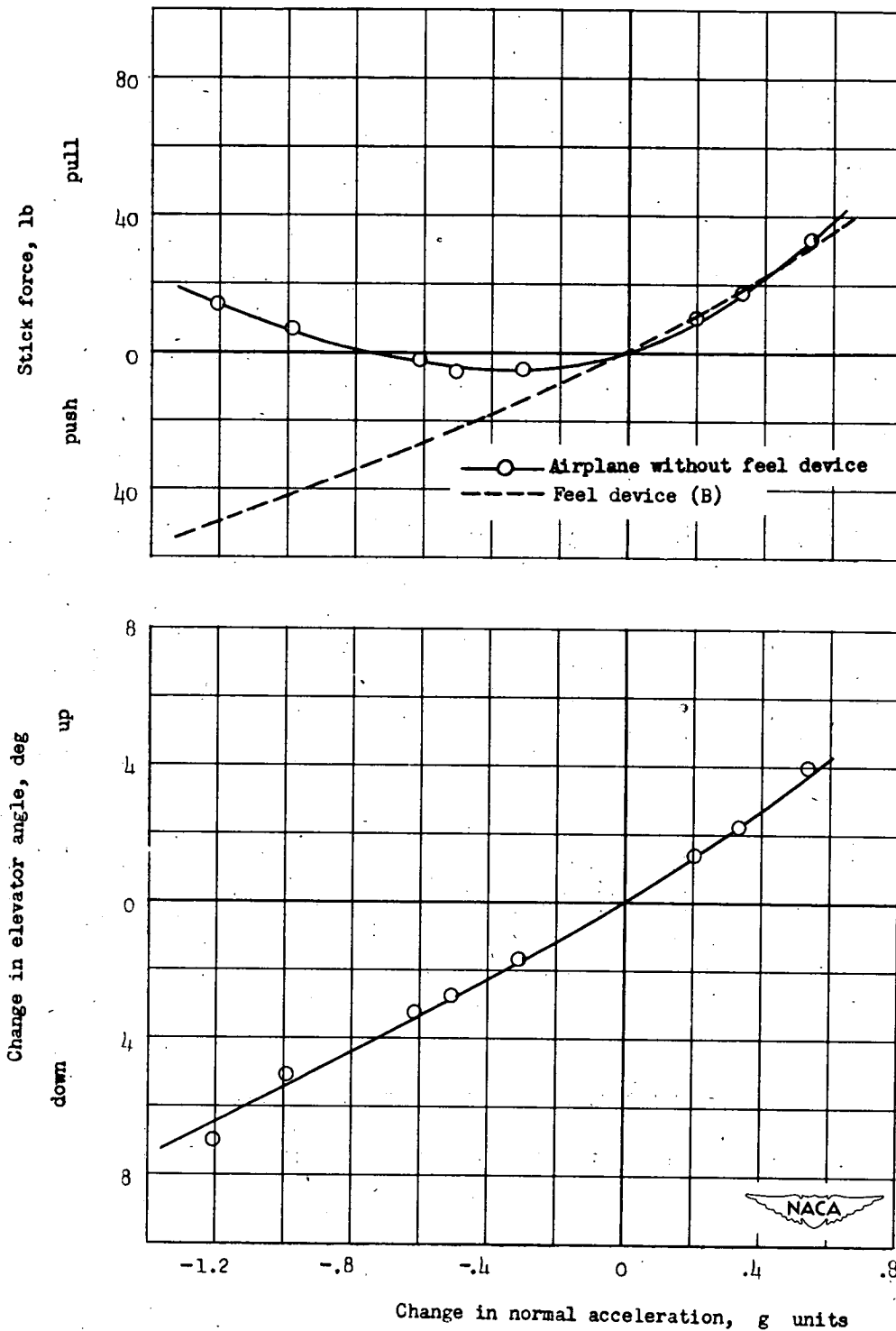
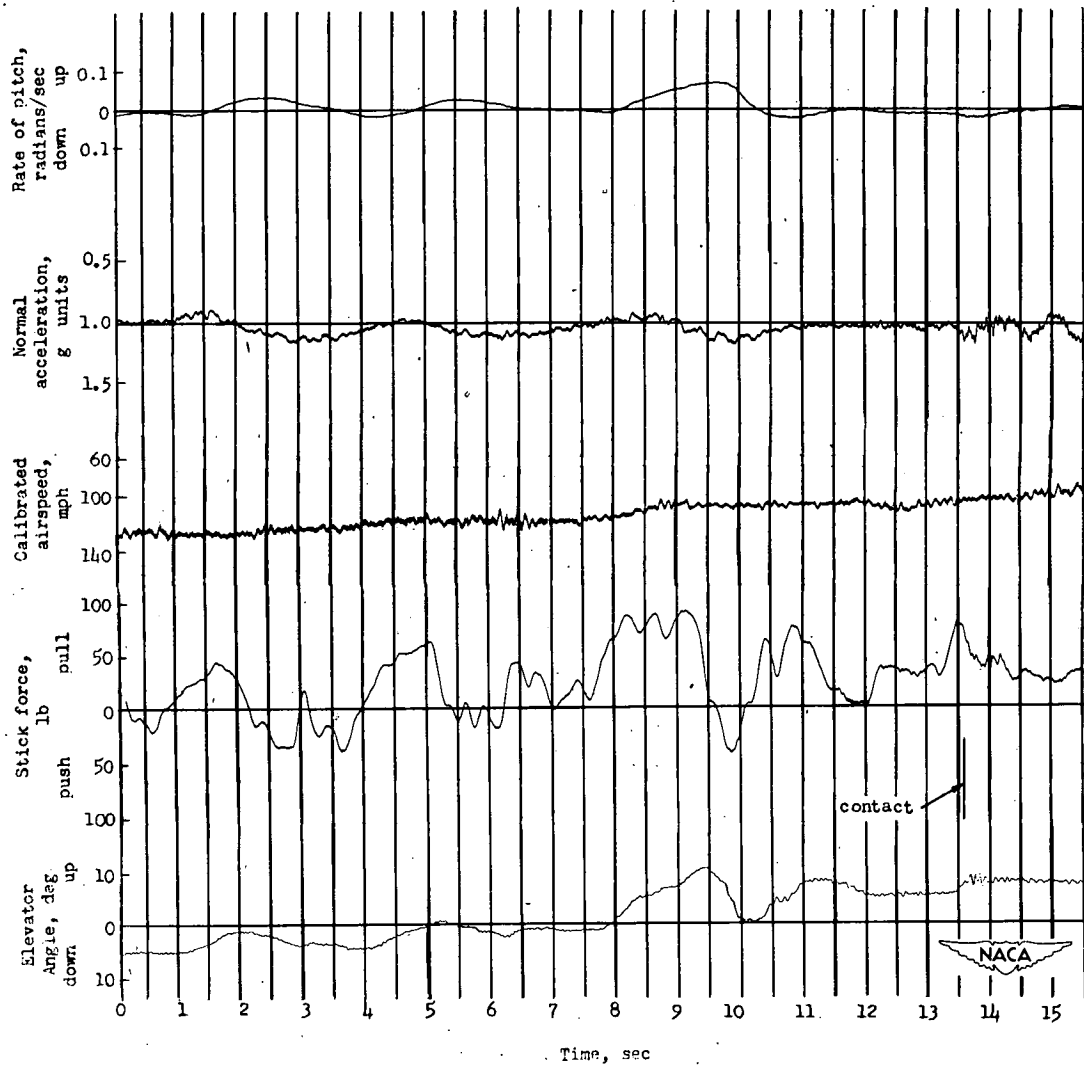
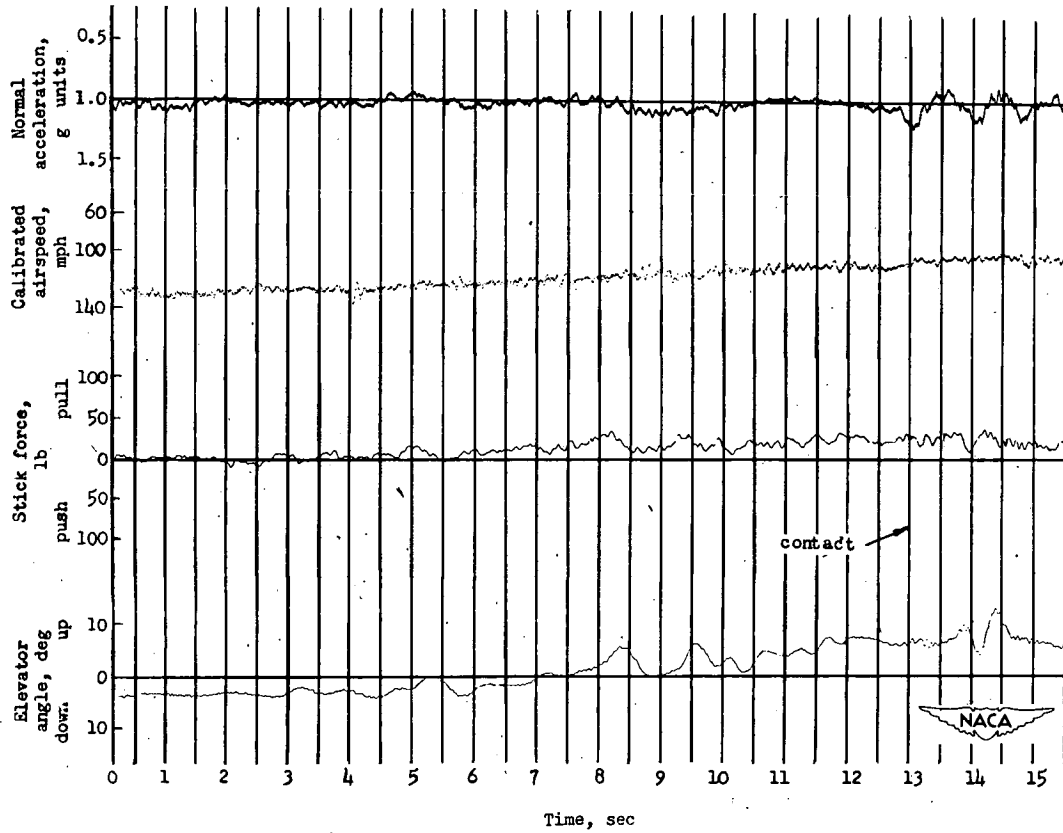

Figure 18.- Variation of stick force and elevator angle with normal acceleration for the airplane without the feel device in the approach condition showing elevator overbalance. Calculated feel-device forces shown for comparison.



(a) Airplane without feel device.

Figure 19.- Time histories of landings.



(b) Feel-device setting A.

Figure 19.- Continued.

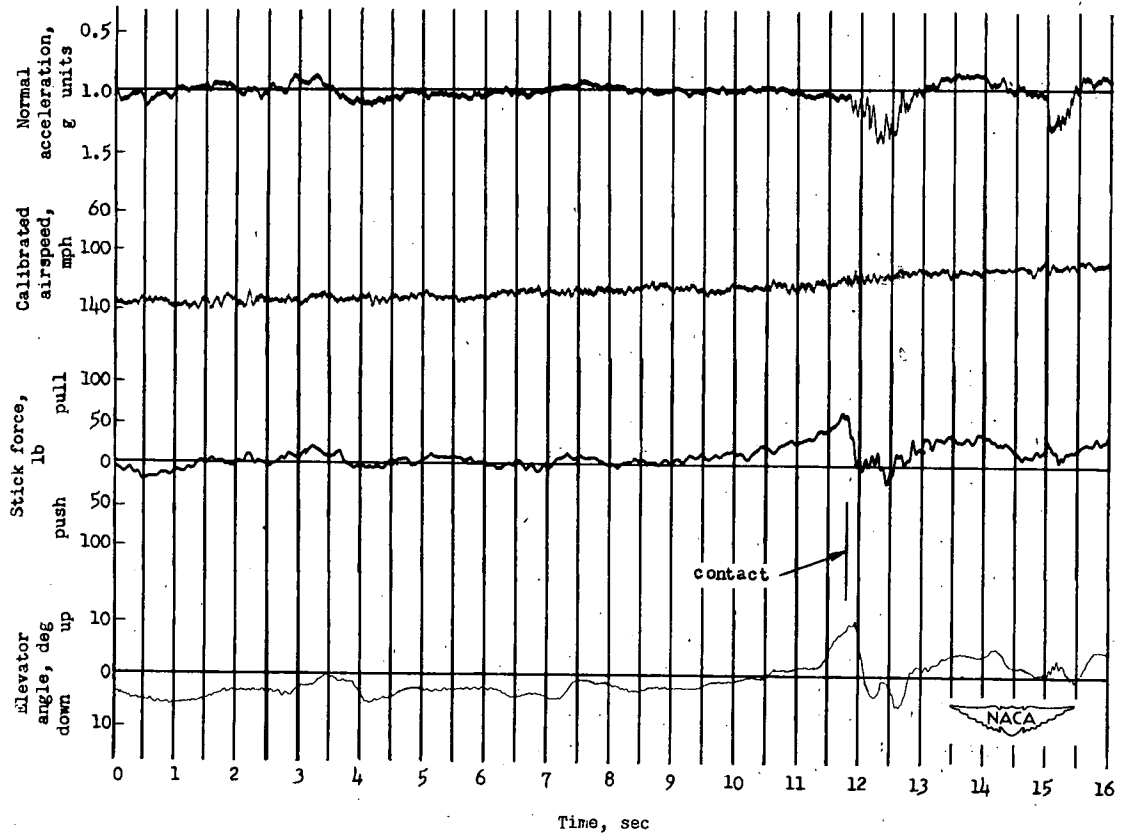

(c) Feel-device setting B.

Figure 19.- Continued.

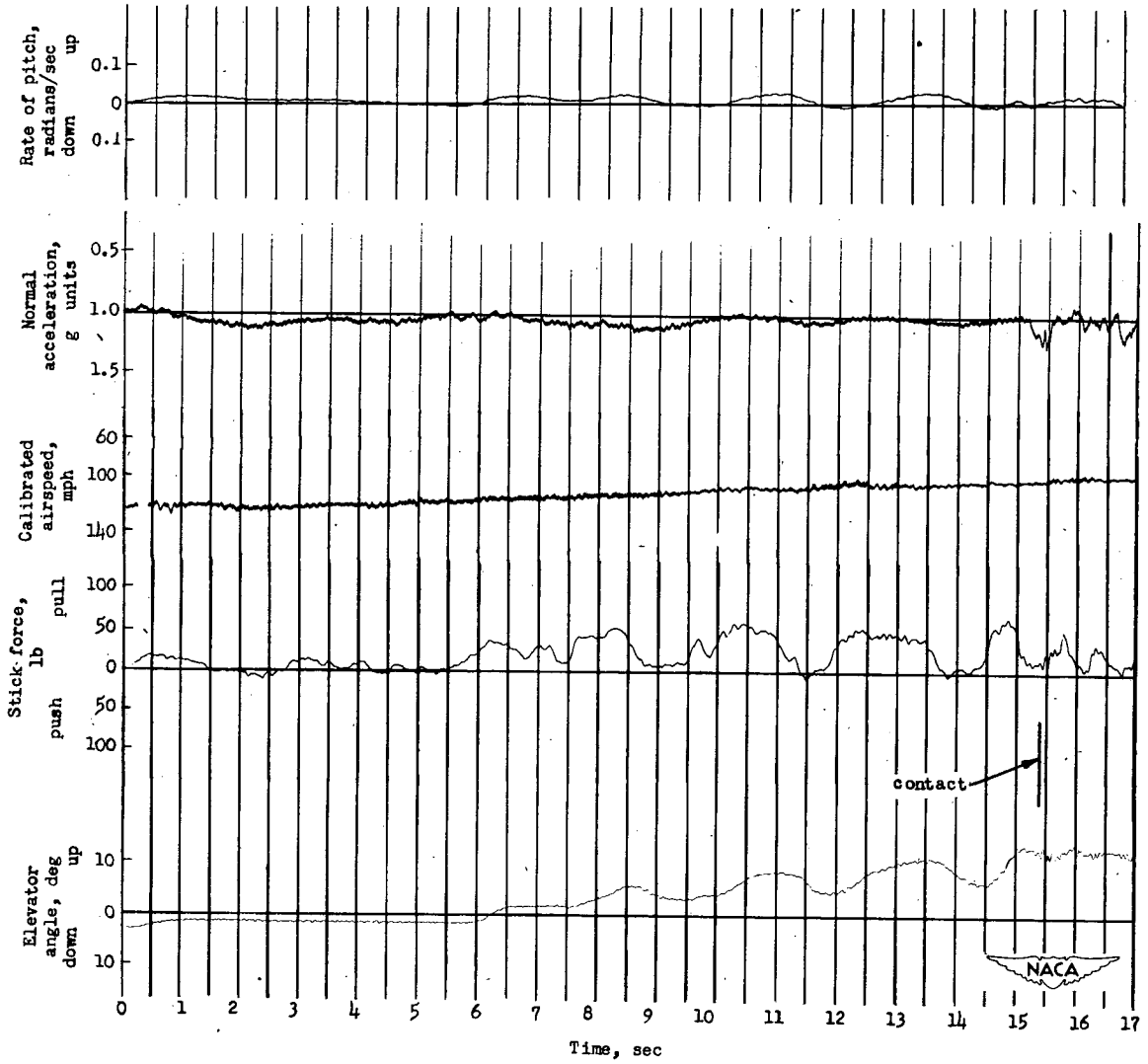

(d) Feel-device setting C.

Figure 19.- Concluded.

NACA TN 2496

National Advisory Committee for Aeronautics.
FLIGHT INVESTIGATION OF A MECHANICAL FEEL DEVICE IN AN IRREVERSIBLE ELEVATOR CONTROL SYSTEM OF A LARGE AIRPLANE. B. Porter Brown, Robert G. Chilton and James B. Whitten. October 1951. 47p. diagrs., photos. (NACA TN 2496)

Data are presented showing the flight characteristics of a large airplane having a control-surface booster and mechanical feel device in the elevator-control system. The tests were made with various force gradients provided by the adjustable feel device. The booster was set to operate at a very high boost ratio throughout the tests so that the measured or apparent stick-free stability would be influenced only slightly by the aerodynamic hinge moments. The results show the effect of the feel device on the handling qualities of the test airplane and also the design features which should be incorporated in such feel devices.

Copies obtainable from NACA, Washington



1. Stability, Longitudinal - Static (1.8.1.1.1)
2. Stability, Longitudinal - Dynamic (1.8.1.2.1)
3. Control, Longitudinal (1.8.2.1)
4. Flying Qualities (1.8.5)
 - I. Brown, B. Porter
 - II. Chilton, Robert G.
 - III. Whitten, James B.
 - IV. NACA TN 2496

NACA TN 2496

National Advisory Committee for Aeronautics.
FLIGHT INVESTIGATION OF A MECHANICAL FEEL DEVICE IN AN IRREVERSIBLE ELEVATOR CONTROL SYSTEM OF A LARGE AIRPLANE. B. Porter Brown, Robert G. Chilton and James B. Whitten. October 1951. 47p. diagrs., photos. (NACA TN 2496)

Data are presented showing the flight characteristics of a large airplane having a control-surface booster and mechanical feel device in the elevator-control system. The tests were made with various force gradients provided by the adjustable feel device. The booster was set to operate at a very high boost ratio throughout the tests so that the measured or apparent stick-free stability would be influenced only slightly by the aerodynamic hinge moments. The results show the effect of the feel device on the handling qualities of the test airplane and also the design features which should be incorporated in such feel devices.

Copies obtainable from NACA, Washington



1. Stability, Longitudinal - Static (1.8.1.1.1)
2. Stability, Longitudinal - Dynamic (1.8.1.2.1)
3. Control, Longitudinal (1.8.2.1)
4. Flying Qualities (1.8.5)
 - I. Brown, B. Porter
 - II. Chilton, Robert G.
 - III. Whitten, James B.
 - IV. NACA TN 2496

NACA TN 2496

National Advisory Committee for Aeronautics.
FLIGHT INVESTIGATION OF A MECHANICAL FEEL DEVICE IN AN IRREVERSIBLE ELEVATOR CONTROL SYSTEM OF A LARGE AIRPLANE. B. Porter Brown, Robert G. Chilton and James B. Whitten. October 1951. 47p. diagrs., photos. (NACA TN 2496)

Data are presented showing the flight characteristics of a large airplane having a control-surface booster and mechanical feel device in the elevator-control system. The tests were made with various force gradients provided by the adjustable feel device. The booster was set to operate at a very high boost ratio throughout the tests so that the measured or apparent stick-free stability would be influenced only slightly by the aerodynamic hinge moments. The results show the effect of the feel device on the handling qualities of the test airplane and also the design features which should be incorporated in such feel devices.

Copies obtainable from NACA, Washington



1. Stability, Longitudinal - Static (1.8.1.1.1)
2. Stability, Longitudinal - Dynamic (1.8.1.2.1)
3. Control, Longitudinal (1.8.2.1)
4. Flying Qualities (1.8.5)
 - I. Brown, B. Porter
 - II. Chilton, Robert G.
 - III. Whitten, James B.
 - IV. NACA TN 2496

NACA TN 2496

National Advisory Committee for Aeronautics.
FLIGHT INVESTIGATION OF A MECHANICAL FEEL DEVICE IN AN IRREVERSIBLE ELEVATOR CONTROL SYSTEM OF A LARGE AIRPLANE. B. Porter Brown, Robert G. Chilton and James B. Whitten. October 1951. 47p. diagrs., photos. (NACA TN 2496)

Data are presented showing the flight characteristics of a large airplane having a control-surface booster and mechanical feel device in the elevator-control system. The tests were made with various force gradients provided by the adjustable feel device. The booster was set to operate at a very high boost ratio throughout the tests so that the measured or apparent stick-free stability would be influenced only slightly by the aerodynamic hinge moments. The results show the effect of the feel device on the handling qualities of the test airplane and also the design features which should be incorporated in such feel devices.

Copies obtainable from NACA, Washington



1. Stability, Longitudinal - Static (1.8.1.1.1)
2. Stability, Longitudinal - Dynamic (1.8.1.2.1)
3. Control, Longitudinal (1.8.2.1)
4. Flying Qualities (1.8.5)
 - I. Brown, B. Porter
 - II. Chilton, Robert G.
 - III. Whitten, James B.
 - IV. NACA TN 2496