

N 62 54420

# CASE FILE COPY

*loan only*

NACA TN 2420

## NATIONAL ADVISORY COMMITTEE FOR AERONAUTICS

TECHNICAL NOTE 2420

INVESTIGATION OF 75-MILLIMETER-BORE CYLINDRICAL-  
ROLLER BEARINGS AT HIGH SPEEDS

III - LUBRICATION AND COOLING STUDIES - OIL INLET  
DISTRIBUTION, OIL INLET TEMPERATURE, AND GENERALIZED  
SINGLE-OIL-JET COOLING-CORRELATION ANALYSIS

By E. Fred Macks and Zolton N. Nemeth

Lewis Flight Propulsion Laboratory  
Cleveland, Ohio



Washington

July 1951

NACA FILE COPY

Loan expires on last  
date stamped on back cover.

PLEASE RETURN TO  
DIVISION OF RESEARCH INFORMATION  
NATIONAL ADVISORY COMMITTEE  
FOR AERONAUTICS

Washington 25, D. C.

NATIONAL ADVISORY COMMITTEE FOR AERONAUTICS

TECHNICAL NOTE 2420

INVESTIGATION OF 75-MILLIMETER-BORE CYLINDRICAL-  
ROLLER BEARINGS AT HIGH SPEEDS

III - LUBRICATION AND COOLING STUDIES - OIL INLET  
DISTRIBUTION, OIL INLET TEMPERATURE, AND  
GENERALIZED SINGLE-OIL-JET COOLING-CORRELATION ANALYSIS

By E. Fred Macks and Zolton N. Nemeth

SUMMARY

The results of an experimental investigation of the effect of oil inlet distribution and oil inlet temperature on the inner- and outer-race temperatures of 75-millimeter-bore (size 215) cylindrical-roller inner-race-riding cage-type bearings are reported. A radial-load test rig was used over a range of DN values (product of the bearing bore in mm and the shaft speed in rpm) from  $0.3 \times 10^6$  to  $1.2 \times 10^6$  and static radial loads from 7 to 1113 pounds.

Oil inlet distribution was found to be an important factor in the lubrication and cooling effectiveness of a given quantity of oil.

Oil supplied by multiple jets (nonopposed) produced appreciably lower inner-race temperatures, outer-race temperatures, and outer-race circumferential temperature gradients at a given oil flow than did oil supplied by a single-jet, single-opposed-jet, multiple-opposed-jet, or outer-race-hole distribution.

Oil supplied by single-opposed jets produced lower inner-race and outer-race bearing temperatures at a given oil flow than did oil supplied by a single jet, particularly at low oil flows.

The inner- and outer-race temperatures decreased from  $0.5^\circ$  to  $1^\circ$  for each  $1^\circ$  F decrease in oil inlet temperature over the range of oil inlet temperatures from  $100^\circ$  to  $205^\circ$  F; the exact decrease depended upon the particular operating condition.

It is possible to generalize the test-rig results for single-jet lubrication so that the inner-race or the outer-race bearing temperatures may be predicted from a single curve regardless of whether

speed, load, oil flow, oil inlet temperature, oil inlet viscosity as affected by oil inlet temperature; oil-jet diameter, or any combination of these parameters is varied.

## INTRODUCTION

The investigation reported herein is a continuation of the work reported in references 1 and 2, and was conducted at the NACA Lewis laboratory. The effects of speed, load, and cage type upon inner- and outer-race bearing temperatures and upon roller slip are reported in reference 1, and the effects of oil flow, oil-inlet location, oil-inlet angle, and oil-jet diameter for single-jet lubrication are reported in reference 2. The effect of oil inlet temperature on bearing operating temperature is briefly reported in reference 3 although the range of DN values (product of bearing bore in mm and shaft speed in rpm) was limited to a maximum of  $0.56 \times 10^6$ .

A comparison and an evaluation of the effects of oil inlet distribution and oil inlet temperature on inner- and outer-race bearing operating temperatures, as determined in the radial-load-bearing test rig over a wide range of operating variables, is presented herein. A generalization of the test-rig results for single-jet lubrication by means of a cooling-correlation analysis is also presented.

Cylindrical-roller bearings currently employed as the turbine roller bearing in commercial aircraft turbojet engines were used as test bearings. These bearings were of 75-millimeter bore (size 215), 25-millimeter width, and 130-millimeter outside diameter and were equipped with one-piece inner-race-riding brass (bronze) cages. The ranges of controlled variables used in the radial-load-bearing test rig were: load, 7 to 1113 pounds; DN,  $0.3 \times 10^6$  to  $1.2 \times 10^6$ ; oil inlet temperature,  $100^\circ$  to  $205^\circ$  F; oil flow, approximately 1.4 to 12 pounds per minute. Five methods of supplying oil to the bearings were investigated. External heat was not applied to the bearing housing or to the shaft.

A theoretical analysis was conducted in order to generalize the results and thus provide a practicable means of estimating the bearing-temperature change due to a change in such operating variables as DN, oil flow, oil inlet temperature, and oil-jet diameter.

## APPARATUS

Bearing rig. - The bearing rig (fig. 1) used in this investigation is described in references 1 and 2. The bearings were mounted on one end of the test shaft, which was supported in cantilever fashion so that component parts of the bearing and the lubricant flow could be observed during operation. Radial load was applied to the test bearing by means of a lever and dead-weight system in such a manner that the outer race of the test bearing was essentially unaffected by small shaft deflections or by small shaft and load-arm misalignments.

Drive equipment. - The drive equipment is described in reference 1. The possible speed range of the test shaft is 800 to 50,000 rpm.

Test bearings. - The four test bearings (table I) used for this investigation were cylindrical roller bearings of the type currently used as turbine roller bearings of a commercial aircraft turbojet engine. The bearing dimensions were 75-millimeter bore, 130-millimeter outside diameter, and 25-millimeter width. The bearings were equipped with inner-race-riding brass (bronze) cages. The operating conditions imposed on this bearing in engine service are as follows: DN range,  $0.3 \times 10^6$  to  $0.86 \times 10^6$ ; approximate gravity load, 375 pounds; oil flow, 0.8 to 2 pounds per minute.

The bearings investigated are numbered consecutively from the first parts of this investigation (references 1 and 2); bearing 5 of reference 1 is the same as bearing number 5 that is discussed herein.

Temperature measurements. - The method of temperature measurement is fully described in reference 1. Briefly, for measuring outer-race test-bearing temperatures six iron-constantan thermocouples were located at  $60^\circ$  intervals around the outer-race periphery at the axial-center line. For measuring inner-race test-bearing temperatures, a copper-constantan thermocouple was pressed against the bore of the inner race at the axial midpoint of the test bearing; the voltage was transmitted from the rotating shaft by means of slip rings.

Lubrication system. - The lubricating system was the same as that described in references 1 and 2 with the exception that special labyrinth-seal type oil-collector rings were used when it was necessary to determine the flow from each side of the test bearing. The oil flow to the bearing was determined by means of calibrated rotameters, and the oil flow through the test bearing was determined by collecting and weighing the oil from both faces of the bearing.

Cage-speed determination. - The cage speed was determined by the system described in reference 1.

Test-bearing measurements. - The test bearings were measured in the same manner as described in reference 1.

#### PROCEDURE

Lubrication of test bearings. - The effect of the circumferential location of the oil jet (with respect to the load vector) on operating temperatures of bearing 8 was determined at 60° circumferential intervals using a single jet of 0.089-inch diameter and a lubricant flow of 2.75 pounds per minute directed at the cage-locating surface normal to the bearing face.

The effect of oil inlet distribution on bearing operating temperature was determined over a range of speeds and oil flows by supplying lubricant at a constant inlet temperature to the test bearing by five methods. The methods employed may be summarized as follows (also see fig. 2):

- (a) Single jet circumferentially indexed; orifice diameter, 0.089 inch
- (b) Single-opposed jets (one jet each side); orifice diameter, 0.063 inch
- (c) Multiple jets from circular manifold; 12 orifices each of 0.024 inch diameter
- (d) Multiple-opposed jets from circular manifolds; 24 orifices (12 each side) each of 0.024 inch diameter
- (e) Single radial hole in outer race; orifice diameter, 0.089 inch

The effect of oil inlet temperature on bearing operating temperatures was determined by supplying oil to the unloaded side of the bearing at the 12 o'clock position through a single jet of 0.050-inch diameter. The effects of oil inlet temperatures of 100°, 135°, 170°, and 205° F were investigated over a range of oil inlet pressures from 25 to 400 pounds per square inch (oil flows 2.2 to 9.3 lb/min).

The temperature as well as the quantity of oil that drained from both sides of the test bearing was measured in order to calculate the energy absorbed by both the deflected and the transmitted oil. The properties of the lubricating oil used in the test rig are given in figure 3. This oil is of the same type as that reported in

references 1 and 2, and is a commercially prepared blend of a highly refined paraffin base with a small percentage of a polymer added to improve viscosity index. Volatility data for the oil used is given in table II and discussed in appendix A.

Lubrication of support bearings. - The support bearings were lubricated in the same manner as described in reference 1. The temperature of the oil to the support bearings and to the test bearing was held constant for all runs.

## RESULTS AND DISCUSSION

The results of the experimental investigation are presented in figures 4 to 13. Bearing temperature was chosen as the principal criterion of operation inasmuch as, in the final analysis, temperature is an over-all indication of the effects of all the operating variables. An indication of the reproducibility of results of a specific bearing is given in reference 1.

### Distribution

Effect of oil-jet circumferential location. - The question of whether more heat is generated in the load zone where theoretical roller speed may be approached, or  $180^\circ$  from the load zone where a considerable deviation from pure rolling motion may occur (references 4 to 6) is a significant factor in bearing-lubrication analysis.

The effect of oil-inlet circumferential location (with respect to the load vector) on outer-race maximum and minimum temperatures and inner-race temperature of bearing 8 was determined for a DN value of  $1.2 \times 10^6$  and loads of 368 and 1113 pounds. The circumferential location of the oil jet from the center of the load zone was found to have a negligible effect on bearing operating temperatures under such loads.

For a given oil-jet location, the maximum outer-race temperature occurred in the region  $240^\circ$  to  $360^\circ$  after the oil-jet location in the direction of shaft rotation, whereas the minimum outer-race temperatures occurred in the region  $0^\circ$  to  $120^\circ$  after the oil-jet location in the direction of shaft rotation regardless of the relative location of the oil jet with respect to the load vector. The exact effect of this temperature gradient about the outer race is unknown; it may, however, cause thermal stresses to be set up in the outer race, or it may cause the outer race to become out of round with resulting shaft misalignment.

Effect of single jet and single-opposed jets. - The effect of oil flow on the outer-race-maximum, outer-race-mean (average of six outer-race temperature readings), outer-race-minimum, and inner-race operating temperatures of bearing 6 is shown in figure 4 where single-jet (0.089-in. diam.) and single-opposed-jet (2 jets each of 0.063 in. diam.) lubrication are compared at DN values from  $0.3 \times 10^6$  to  $1.2 \times 10^6$ , oil flows from 2 to 12 pounds per minute, and a load of 368 pounds. The oil-jet diameters were so chosen that at a given flow the oil inlet velocities per stream were equal in the two systems.

At low DN values ( $0.3 \times 10^6$ ), little difference exists between operating temperatures of the two systems. At higher DN values, however, lubrication by the single-opposed jets generally results in lower outer-race temperatures except at the high flow rates. The inner-race temperature is significantly lower over the entire flow range when the lubricant is supplied by single-opposed jets rather than by a single jet.

As an example of the magnitude of the differences in bearing operating temperatures caused by the two foregoing methods of lubrication, it is noted that at an oil flow of 3 pounds per minute and a DN value of  $1.2 \times 10^6$ , the outer-race-maximum temperature is  $19^\circ$  F less and the inner-race temperature is  $34^\circ$  F less when the bearing is lubricated by single-opposed jets rather than by a single jet.

Effect of single jet, outer-race hole, multiple jets, and multiple-opposed jets. - The effect of oil distribution, on outer-race maximum, mean, minimum and inner-race operating temperatures of bearing 5 is shown in figure 5 where single-jet (0.089-in. diam.), outer-race-hole (0.089-in. diam.), multiple-jet (12 jets each 0.024 in. diam.), and multiple-opposed-jet (24 jets - 12 each side, each 0.024-in. diam.) lubrication methods are compared at DN values of  $0.735 \times 10^6$  and  $1.2 \times 10^6$ , loads of 7 and 368 pounds and oil flows from about 1.5 to 10.3 pounds per minute.

With one exception, lubrication and cooling by means of the multiple jets was the most effective of the four methods investigated inasmuch as this method resulted in the lowest outer-race-maximum and inner-race temperatures for any given oil flow over the flow range investigated. The one exception was at a DN of  $0.735 \times 10^6$  and a load of 368 pounds (fig. 5(c)) where the multiple-opposed-jet lubrication method produced slightly lower operating temperatures. The single outer-race-hole lubrication method was the least effective of the four methods at a DN of  $0.735 \times 10^6$ ; the single jet and the outer-race-hole methods were the least effective methods of lubrication at a DN of  $1.2 \times 10^6$  over the flow range investigated.

Large differences in the bearing operating temperatures can be effected by changing the lubrication system; for example, it is noted from figure 5(d) that, at a DN value of  $1.2 \times 10^6$ , a load of 368 pounds, and an oil flow of 6 pounds per minute, the outer-race-maximum temperature is  $60^\circ$  F less and the inner-race temperature  $92^\circ$  F less when lubricated by the multiple-jet method rather than by a single jet.

Outer-race circumferential temperature distributions for four methods of lubrication are compared in polar form in figure 6. The oil flow in each case was 2.8 pounds per minute. An appreciable circumferential temperature gradient exists when the bearing is lubricated by a single jet, the outer-race hole, and the multiple-opposed jets. The multiple-jet method shows the most favorable results for this investigation in that the temperature distribution about the circumference of the outer race is nearly uniform, and the outer-race-maximum temperature is appreciably lower than that obtained with the other methods. The outer-race circumferential temperature gradient is only  $5^\circ$  F for the multiple-jet method in contrast to  $93^\circ$  F for lubrication by means of the outer-race hole. It is probable, however, that with multiple radial holes in the outer race (for example, three to six equally spaced holes) a more uniform circumferential temperature gradient would result together with lower outer-race-maximum temperatures. (The data of figs. 5 and 6 are for bearing 5, which ran unusually hot but otherwise satisfactorily. For example, bearing 5 ran with approximately a  $50^\circ$  F higher outer-race-maximum temperature and a  $100^\circ$  F higher inner-race temperature than did similar bearings at a DN value of  $1.2 \times 10^6$ , a load of 368 lb and an oil flow of 2.8 lb/min.)

Effect of oil inlet distribution on cage slip. - The effect of oil distribution on cage slip over a range of oil flows from 1.5 to 10.3 pounds per minute for the previously mentioned four methods of lubrication was investigated at DN values of  $0.735 \times 10^6$  and  $1.2 \times 10^6$  and a load of 7 pounds.

Little difference in cage slip for the different methods of lubrication was found over the flow range investigated. Normally, the cage slip is not readily reproducible particularly at the higher DN values; the variations may depend on a number of factors including vibration, extent of roller skewing, and clearance within the bearing (reference 1). The data from the present investigation, however, were of a more reproducible nature (14 to 25 percent slip at a DN of  $0.735 \times 10^6$  and 39 to 62 percent slip at a DN of  $1.2 \times 10^6$ ) than were the data of reference 1. This increased reproducibility is due in part to the relatively small diametral clearance of test bearing 5 (table I).



## Oil Inlet Temperature and Flow Through Bearing

Effect of oil inlet temperature. - The effect of oil flow on outer-race-maximum and inner-race bearing temperatures of test bearing 10 for DN values of  $0.3 \times 10^6$ ,  $0.735 \times 10^6$ ,  $0.995 \times 10^6$ , and  $1.2 \times 10^6$  is shown in figure 7 for oil inlet temperatures of  $100^\circ$ ,  $135^\circ$ ,  $170^\circ$  and  $205^\circ$  F. The bearing operating temperatures are markedly influenced by a change of oil inlet temperature. The decrease in both inner- and outer-race bearing temperatures is between 50 and 100 percent of the decrease in oil inlet temperature for the conditions investigated.

At a DN of  $0.3 \times 10^6$  and an oil inlet temperature of  $205^\circ$  F, the outer-race-maximum and the inner-race temperatures are practically independent of the quantity of oil flow. As the oil-inlet temperature is decreased, however, the cooling effect of the oil becomes evident as is noted by the decrease in bearing temperatures with increase in oil flow. This decrease in bearing temperature with increase in oil flow is more evident at the higher DN values.

An approximately straight-line relation between the temperature difference  $T_B - T_{OI}$  (where  $T_B$  is the bearing temperature and  $T_{OI}$  is the oil inlet temperature) and oil inlet temperature exists for both the outer-race-maximum and the inner-race temperature for all DN values investigated when  $T_B - T_{OI}$  is plotted (plot not shown) against  $T_{OI}$  for a given oil flow. The decrease in  $T_B - T_{OI}$  with an increase in oil inlet temperature over the flow range investigated indicates the combined effects of a decrease of heat generated within the bearing at the higher oil inlet temperatures that results from a decrease in oil viscosity with resultant smaller churning losses, an increase of the conduction, convection, and radiation losses from the bearing, and a change in the film coefficient of heat transfer.

Effect of operating variables on oil temperatures and rates of flow from each side of bearing. - The effect of total oil flow through a single jet on the oil outlet temperatures and rates of flow from each side of bearing 10 with DN as parameter is illustrated in figure 8 for oil inlet temperatures of  $100^\circ$ ,  $135^\circ$ ,  $170^\circ$  and  $205^\circ$  F.

For all conditions investigated, the oil which passes through the bearing (transmitted oil) undergoes an appreciably greater temperature rise than does the oil leaving the supply side (deflected oil). The oil outlet temperatures of both the deflected and the transmitted oil decrease with increase in oil flow, whereas an increase of oil outlet temperatures occurs on both sides of the bearing for an increase in DN value over the flow range investigated.

The oil-flow ratio (deflected oil to transmitted oil) decreases with an increase in total oil flow, particularly at the higher DN values. The trend of this flow ratio is, in general, to increase with an increase in DN. This trend is practically unaffected by a change in oil inlet temperature. The flow ratio varies from about 4 to 25 depending on the operating condition.

At a given DN value and total oil flow, the flow ratio is approximately constant for the various oil inlet temperatures over the flow range investigated. Inasmuch as the quantity of transmitted oil is very small at low total oil flows and high DN values, any small change in this quantity is reflected as a large change in the flow ratio.

### ANALYSIS OF EXPERIMENTAL RESULTS

Explanations of all phenomena observed are unavailable at this time; the following discussion may, however, lead to a better understanding of the results obtained.

#### Distribution

Single jet and single-opposed jet distribution. - The cooling effectiveness of various sizes of single jets is compared in figure 9 with the cooling effectiveness of single-opposed jets, which have the same inlet velocity per stream as the single jet of 0.089-inch diameter. (The data for the 0.066-, 0.048-, and 0.035-in. diam. single jets are from reference 2.)

The data of figure 9 show that the cooling effectiveness obtained with single-opposed-jet lubrication at a given flow can be obtained with single-jet lubrication if the oil inlet velocity is sufficiently increased. For example, to obtain the same outer-race-maximum bearing temperature with a single jet (0.048-in. diam.) as with single-opposed jets, at an oil flow of 3 pounds per minute, the single-jet oil velocity must be approximately  $3\frac{1}{2}$  times the value of the single-opposed-jet oil inlet velocity. At an oil flow of 3 pounds per minute, to obtain the same inner-race temperature with a single jet (0.035-in. diam.) as with single-opposed jets, would require the value of the oil inlet velocity of the single jet to be approximately  $6\frac{1}{2}$  times that of the single-opposed jets.

The lesser effectiveness of the single-opposed jets in comparison with single jets at the higher oil flows with respect to outer-race-maximum temperature indicates that, with high oil flow directed into

the bearing from both sides at the same circumferential location, the churning within the bearing may be a significant factor. This result would suggest that to obtain the least restricted axial flow through the bearing the single-opposed jets should be mounted circumferentially opposite each other rather than being mounted as opposed jets.

Single-jet and multiple-jet distribution. - The cooling effectiveness of the multiple jets is far superior to that of the single jet for all operating conditions investigated (fig. 6). Inasmuch as single-opposed jets are in general superior to a single jet it is to be expected that multiple-opposed jets would result in the greatest cooling effectiveness of the methods investigated. This observation is, however, not entirely without qualification.

Single jet, and multiple-opposed jet distribution. - Whereas the cooling effectiveness of the multiple-opposed jets was generally superior to that of the single jet (except at low flows and high DN values), the multiple-opposed jets are not generally as effective at a given oil flow as is the multiple nonopposed-jet system (fig. 5).

This apparent inconsistency may be explained by including a consideration of the oil inlet velocity in the analysis. The oil inlet velocity per stream for the multiple-opposed jets is one-half that for the multiple-nonopposed-jet system. The shielding effect of the windage barrier set up by the high-speed bearing components is more pronounced for the multiple-opposed jets than for the multiple-nonopposed jets inasmuch as the velocity per stream of the multiple-opposed jets is in the critically low range. In addition, a lower film coefficient of heat transfer (references 7 and 2) results in the case of the multiple-opposed jets because of the reduced effective velocity of the oil which penetrates the windage barrier.

The significant fact brought out by the data of figure 7 is that the effect of lubricant distribution cannot be considered independent of the effect of oil inlet velocity. It is implied by the results presented herein that, for maximum cooling effectiveness, the multiple-opposed-jet systems should be designed for maximum practicable oil inlet velocity with the opposed-jet distribution staggered so as not to restrict the flow of oil axially through the bearing.

### Oil Inlet Temperature

Bearing operating temperature above ambient-air temperature. - The outer-race-maximum and the inner-race operating temperatures of bearing 10 above the ambient-air temperature in the test rig are plotted against DN in figure 10 with oil inlet temperature as a parameter for single-jet lubrication.

The difference between bearing temperature and ambient-air temperature ( $T_B - T_{AA}$ ) increases approximately as a straight line with an increase in DN. Bearing temperature increases linearly with an increase in DN value (reference 1); therefore,  $T_{AA}$  also increases linearly with an increase in DN.

At a given DN,  $T_B - T_{AA}$  is only slightly influenced by a change in oil inlet temperature inasmuch as both  $T_B$  and  $T_{AA}$  increase appreciably with an increase of the oil inlet temperature  $T_{OI}$ .

Horsepower rejected to oil. - The total horsepower rejected to the oil as well as the horsepower rejected to the deflected and transmitted oil is shown in figure 11 with oil inlet temperature as parameter. The horsepower rejected to the oil was calculated from the mass flow of oil, the temperature rise of the oil, and the specific heat of the oil.

Although the transmitted oil leaves the bearing at a considerably higher temperature than does the deflected oil (see fig. 8), the deflected oil accounts for the greater proportion of the total horsepower rejected to the oil because only 4 to 25 percent of the total oil was transmitted through the bearing. At a DN value of  $1.2 \times 10^6$ , and over the flow range and oil inlet temperature range investigated, the deflected oil accounts for between 65 to 90 percent of the total horsepower rejected to the oil. The horsepower rejected to the oil increases with an increase in DN. The rate of increase of horsepower rejection with increase in oil flow is greater for the transmitted oil than for the deflected oil. This greater rejection of horsepower to the transmitted oil is attributed, at least in part, to the additional heating of the transmitted oil due to viscous shear as the oil passes through the bearing.

The rate of increase of horsepower rejected to the oil with oil flow increases with an increase in DN. The horsepower rejected to the oil decreases with an increase in oil inlet temperature.

The rejection of the greater proportion of the total horsepower to the deflected oil partly accounts for the greater effectiveness of the single-opposed jets over the single jet at a given flow and inlet velocity (fig. 4).

#### COOLING-CORRELATION THEORY

The cooling-correlation analysis presented in reference 2 is derived herein by means of dimensional analysis to give a form of the correlation equation useful in the present application.

The dimensional method of reasoning is described by Buckingham in reference 8. The variables that apply to the present problem are listed in the following table:

Symbol	Variable	Dimensional formula
N	Bearing speed	$\theta^{-1}$
D	Bearing bore	L
$\mu$	Viscosity based on oil inlet temperature	$ML^{-1}\theta^{-1}$
C	Specific heat of oil at oil inlet temperature	$L^2\theta^{-2}T^{-1}$
$\Delta T$	Temperature rise of bearing above oil inlet temperature	T
d	Oil-jet diameter	L
v	Oil inlet velocity (v is proportional to $M/d^2$ , where M is the mass flow of oil)	$L\theta^{-1}$
W	Bearing load	$ML\theta^{-2}$
k	Thermal conductivity of oil at oil inlet temperature	$ML\theta^{-3}T^{-1}$
$\rho$	Mass density of oil at oil inlet temperature	$ML^{-3}$
x,y,z	Space coordinates in temperature field	L
n	Number of jets	None

The dimensional formulas of the variables are given in the mass M, length L, time  $\theta$ , and temperature T system of dimensions.

The nondimensional groups are formed as described in reference 9 and are related by the following equation when the four independent variables are speed, bore, viscosity, and specific heat.

$$\frac{\Delta TC}{(DN)^2} = \Omega \left[ \frac{\rho D(DN)}{\mu}, \frac{k}{\mu C}, \frac{d}{D}, \frac{v}{DN}, \frac{W}{\mu D(DN)}, \frac{x}{D}, \frac{y}{D}, \frac{z}{D}, n \right] \quad (1)$$

where  $\frac{\Delta TC}{(DN)^2}$  is some function  $\Omega$  of the several nondimensional quantities. As an approximation, the function  $\Omega$  in equation (1) is assumed to be the product of the independent nondimensional groups each raised to an empirically determined power. When written as a power function for a specific point on a specific bearing and for a specific lubrication arrangement, equation (1) may be simplified to the following expression:

$$\frac{\Delta TC}{(DN)^2} = A \left[ \frac{\rho D(DN)}{\mu} \right]^q \left[ \frac{k}{\mu C} \right]^r \left[ \frac{M}{d^2 DN} \right]^s \left[ \frac{d}{D} \right]^t \quad (2)$$

where A, q, r, s, and t are constants that may be determined empirically. The term containing W has been omitted from equation (2) because experimental results showed only a small effect of W on  $\Delta T$  for the range of loads of interest; that is, about 300 to 1100 pounds (reference 1).

For the oil used and for the range of oil inlet temperatures investigated herein, the effects of specific heat, density, and thermal conductivity of the oil are small with respect to the effect of a change of viscosity. In addition, for a given bearing, the quantity D is fixed. For oil inlet temperatures in the range 100° to 205° F and for a given bearing, equation (2) may therefore be simplified to the following expression:

$$\frac{\Delta T}{(DN)^a} = B \left[ \frac{(d)^x}{M} \mu^z \right]^n \quad (3)$$

where B, a, x, z, and n are constants, the values of which are again dependent on a specific bearing location of a specific bearing system.

In the determination of the rise above oil inlet temperature of either the inner- or outer-race temperatures of any bearing system having jet lubrication, equations (2) and (3) are applicable.

In order to apply equation (3) to a specific bearing system, the inner- and outer-race bearing temperatures for a number of representative bearing-operating conditions must be experimentally determined. In the following example, data from figure 7 are used.

Operating conditions. - The specific operating conditions of speeds, oil flows, oil inlet temperatures, and oil-jet diameter used to determine the constants of equation (3) are given in the following table:

Operating condition	DN	Oil flow (lb/min)	Oil inlet temperature (°F)	Oil jet diam. (in.)
1 to 16	$0.3 \times 10^6$	2.3, 4.6, 7.2, 9.2	100, 135, 170, 205	0.050
17 to 32	0.735	2.3, 4.6, 7.2, 9.2	100, 135, 170, 205	0.050
33 to 48	0.995	2.3, 4.6, 7.2, 9.2	100, 135, 170, 205	0.050
49 to 64	1.2	2.3, 4.6, 7.2, 9.2	100, 135, 170, 205	0.050

Inner-race cooling correlation. - The method of determining the exponents of equation (3) for the inner-race cooling correlation is given in appendix B.

The final cooling-correlation curve for the inner-race temperatures is shown in figure 12, which is a plot of equation (3). This curve indicates that when  $\frac{(T_{IR}-T_{OI})}{(DN)^{1.2}}$  is plotted against

$\left[ \frac{(d)^{0.8}}{M} \mu^{0.7} \right]^{0.45}$  a representative straight line results regardless of whether bearing speed, oil flow, oil inlet temperature, or oil inlet viscosity is varied. (The subscripts IR and OI refer to inner race and oil inlet, respectively.) In this investigation, the viscosity was varied only by a change in oil inlet temperature.

The slope of the solid straight line of figure 12 is the constant  $B$  of equation (3). For the conditions investigated,  $B = 15.4 \times 10^{-4}$ . Even though these data were obtained at a load of 368 pounds, the final inner-race cooling-correlation curve may be used as a first approximation for loads from about 300 to 1100 pounds inasmuch as it is shown in reference 1 that the inner-race bearing temperature changes but slightly over this load range. Reference 2 indicates that the correlation equation should also apply for variation in values of oil-jet diameter from 0.023 to 0.129 inch.

The significance of the scatter of figure 12 is illustrated by the broken lines on either side of the final cooling-correlation curve. The dotted lines shown indicate a deviation of  $\pm 5^\circ$  F from the cooling curve at a DN value of  $0.3 \times 10^6$ . This  $\pm 5^\circ$  F spread decreases with an increase in DN as may be seen by the dashed lines, which indicate a deviation of  $\pm 5^\circ$  F from the cooling curve at a DN value of  $0.735 \times 10^6$ .

The estimated range of applicability of the cooling-correlation curve (fig. 12) for the bearing investigated is as follows: DN,  $0.3 \times 10^6$  to  $1.2 \times 10^6$ ; oil inlet temperature,  $100^\circ$  to  $205^\circ$  F; oil flow, 2 to 10 pounds per minute (in order to stay within the range of oil inlet pressures from 5 to 400 lb/sq in., the oil inlet velocity is to be in the range of 10 to 150 ft/sec as determined by equation (2) of reference 2, which states that  $V = 0.0574 \frac{M}{d^2}$ ); oil inlet viscosity,  $1.1 \times 10^{-6}$  to  $5.3 \times 10^{-6}$  reyns; oil-jet diameter, 0.023 to 0.129 inch; load, 300 to 1100 pounds.

Outer-race cooling correlation. - The method of determining the exponents of equation (3) for the outer-race cooling correlation is also given in appendix B.

The final cooling-correlation curve for the outer-race-maximum temperature rise is given in figure 13 where  $\frac{T_{OR} - T_{OI}}{(DN)^{1.2}}$  is plotted

against  $\left(\frac{d^{0.5}}{M} \mu^{0.7}\right)^{0.36}$ . The slope of the solid straight line of

figure 13 is the constant  $B$  of equation (3). For the conditions investigated,  $B = 4.42 \times 10^{-4}$ . The dotted lines shown parallel to the final cooling curve indicate a deviation of  $\pm 5^\circ$  F at a DN of  $0.3 \times 10^6$ ; whereas the dashed lines indicate a deviation of  $\pm 5^\circ$  F at a DN of  $0.735 \times 10^6$ . This  $\pm 5^\circ$  F spread decreases with an increase in DN.



The final outer-race cooling-correlation curve of figure 13 can be used to predict the trend as well as the approximate magnitude of the effect on  $T_{OR}-T_{OI}$  that results when any combination of speed, flow, oil inlet temperature, or viscosity is varied. (For this investigation, the viscosity was varied only by a change in oil inlet temperature.) Even though these data were obtained at a load of 368 pounds, the final outer-race cooling curve may be used as a first approximation for loads from about 300 to 1100 pounds inasmuch as it is shown in reference 1 that the outer-race bearing temperature changes but slightly over this load range. Reference 2 indicates that the correlation equation also holds for variation in value of oil-jet diameter from 0.023 to 0.129 inch.

The estimated range of applicability of the correlation in figure 13 is the same as for figure 12.

#### SUMMARY OF RESULTS

From the experimental investigation of the effects of oil inlet distribution, oil inlet temperature, and oil viscosity on the operating characteristics of 75-millimeter-bore, inner-race-riding cage-type roller bearings as determined in the bearing test rig over a range of high speeds and oil flows, the following results were obtained:

1. Oil inlet distribution was a significant factor in the lubrication and cooling effectiveness of a given quantity of oil. The effectiveness of lubricant distribution depended on oil inlet velocity.
2. Oil supplied to the bearing by multiple jets from a circular manifold produced lower inner-race, outer-race, and outer-race circumferential temperature gradients at a given oil flow than did oil supplied by a single jet, single-opposed jets, or an outer-race hole.
3. Oil supplied by single-opposed jets produced lower inner-race and outer-race bearing temperatures at a given oil flow than did oil supplied by a single jet, particularly at the lower flows.
4. At a given oil flow, oil supplied through a radial hole in the outer race produced inner-race and outer-race-maximum temperatures that were approximately the same as those produced by oil supplied by a single jet.
5. For any given oil-jet location, the maximum outer-race temperature occurred in the region  $240^{\circ}$  to  $360^{\circ}$  F after the oil-jet location in the direction of shaft rotation regardless of the relative location of the oil jet with respect to the load vector.

6. The roller slippage within the bearing was nearly the same for each of the oil supply methods over the flow ranges investigated.

7. The inner- and outer-race temperatures decreased from  $0.5^{\circ}$  to  $1^{\circ}$  F for each  $1^{\circ}$  F decrease in oil inlet temperature over the range of oil inlet temperatures from  $100^{\circ}$  to  $205^{\circ}$  F; the exact decrease depended on the particular operating condition.

8. The oil leaving the supply side of the bearing was found to account for between 65 to 90 percent of the total horsepower absorbed by the oil (the exact value depended on the operating condition) although the oil leaving the side opposite to the supply side undergoes an appreciably greater temperature rise.

9. The ratio of oil leaving the supply side of the bearing to oil leaving the opposite side varied from 4 to 25 depending upon the operating condition.

10. It was found possible to generalize the test-rig results for single-jet lubrication so that the inner- and outer-race bearing temperatures could be predicted from a single curve regardless of whether speed, load, oil flow, oil inlet temperature, oil inlet viscosity as affected by oil inlet temperature, oil-jet diameter, or any combination of the foregoing vary.

11. The cooling-correlation equation (variable oil inlet temperature is included in the analysis) has the following form:

$$\frac{\Delta T}{(DN)^a} = B \left( \frac{d^x}{M} \mu^z \right)^n$$

where  $\Delta T$  is the difference between bearing temperature and oil inlet temperature,  $DN$  is the product of the bearing bore in millimeters and the shaft speed in rpm,  $\mu$  is the oil inlet viscosity in pound seconds per square inch,  $d$  is the oil-jet diameter in inches,  $M$  is the oil flow in pounds per minute and  $B$  is a constant.

12. The constants for the cooling-correlation curve that apply to the bearings investigated as determined in the test rig for both the inner-race and outer-race-maximum bearing temperatures are as follows:

Constant	Inner-race	Outer-race
a	1.2	1.2
B	$15.4 \times 10^{-4}$	$4.42 \times 10^{-4}$
x	.8	.5
z	.7	.7
n	.45	.36

Lewis Flight Propulsion Laboratory,  
National Advisory Committee for Aeronautics,  
Cleveland, Ohio, April 4, 1951.

## APPENDIX A

## VOLATILITY OF LUBRICANT

During operation under severe conditions, bluish white smoke was emitted from the bearing rig. Observation through the transparent windows in the bearing-rig walls showed that the oil foamed violently as it flowed from the bearing. Examination of the bearing surfaces after a run showed slight deposits of varnish or lacquer, carbon, and oxides.

A determination of the volatility of the lubricant, using the modified Moore type apparatus (reference 9), gave the results summarized in table II. Residue from the oil first formed in the Moore type apparatus (table II) at  $390^{\circ}$  F (flash point,  $315^{\circ}$  F).

Certain of the bearing surfaces may have operated many degrees above the temperatures reported herein as measured by the thermocouples located on the inner and outer races. The fact that residue formed on the test bearing during operation even though the observed bearing operating temperatures were less than  $390^{\circ}$  F may also be explained by the facts that oxidation is a function of quantity of dissolved air in the oil and as well as the period during which the oil and the oil-air mist is subjected to a given temperature.

## APPENDIX B

## DETERMINATION OF EXPONENTS FOR COOLING-CORRELATION ANALYSIS

Inner race. - The first step in the determination of the exponent  $n$  of equation (3) for the inner-race temperature of bearing 10 is to plot  $\frac{d^x}{M} \mu^z$  against  $T_{IR}-T_{OI}$  on log-log paper (fig. 14). The subscripts IR and OI refer to the inner race and oil inlet, respectively. The exponent  $x$  was taken as 0.8, which was the value obtained for a range of oil-jet diameters as determined in reference 2. The exponent  $z$  was determined by plotting  $\frac{d^{0.8}}{M} \mu^z$  against  $T_{IR}-T_{OI}$  on log-log paper using various values of  $z$  for each of the DN values investigated. The value of  $z$  for a given DN was taken as that value which resulted in the least scatter of data and the straightest line through the data. The value of  $z$  (0.7) was found to be essentially constant for the DN values investigated.

The exponent  $n$  was obtained for each DN value as the slope of the faired straight line drawn through the data of figure 14. The final value of  $n$  (0.45) for all DN values was taken as the average of the values of  $n$  for the DN values  $0.735 \times 10^6$ ,  $0.995 \times 10^6$ , and  $1.2 \times 10^6$ . The data for the lowest DN value of  $0.3 \times 10^6$  are believed to have the lowest accuracy because they involved the smallest temperature rise and furthermore are of minor interest in comparison with the data at the higher speeds. These data therefore were not used in the determination of  $n$ .

The exponent  $a$  in equation (3) was determined by plotting  $\frac{T_{IR}-T_{OI}}{\left(\frac{d^x}{M} \mu^z\right)^n}$  against DN on log-log paper. The values of  $x = 0.8$ ,  $z = 0.7$ , and  $n = 0.45$  were used for this determination. The slope of the line drawn through the data is the value of  $a$  and was found to be 1.2 for the bearing investigated.

Outer race. - The value of the exponent  $x$  of equation (3) for the outer race was determined from the data of reference 2 to be 0.5. The values of  $z$  and  $n$  of equation (3) for  $T_{OR}-T_{OI}$  were determined by the method applied in the previous section. In order to obtain the exponent  $n$  of equation (3),  $T_{OR}-T_{OI}$  was plotted against  $\frac{d^{0.5}}{M} \mu^{0.7}$  on log-log paper (fig. 15) for DN values of

$0.3 \times 10^6$ ,  $0.735 \times 10^6$ ,  $0.995 \times 10^6$ , and  $1.2 \times 10^6$ . Because of the appreciable scatter at a DN of  $0.3 \times 10^6$ , the value of  $n$  was again determined as the average of the slopes of the other three DN values. The value of  $a$  was determined in the manner described in the previous section for the inner race.

## REFERENCES

1. Macks, E. Fred, and Nemeth, Zolton, N.: Investigation of 75-Millimeter-Bore Cylindrical Roller Bearings at High Speeds. I - Initial Studies. NACA TN 2128, 1950.
2. Macks, E. Fred, and Nemeth, Zolton N.: Investigation of 75-Millimeter-Bore Cylindrical Roller Bearings at High Speeds. II - Lubrication Studies - Effect of Oil-Inlet Location, Angle, and Velocity for Single-Jet Lubrication. NACA TN 2216, 1950.
3. Getzlaff, Günter: Experiments of Ball and Roller Bearings under Conditions of High Speed and Small Oil Supply. NACA TM 945, 1940.
4. Ferretti, Pericle: Experiments with Needle Bearings. NACA TM 707, 1933.
5. Paterson, E. V.: Needle Roller Bearings. The Auto. Eng., vol. XXXIV, no. 448, April 1944, pp. 147-150.
6. Macks, E. Fred: Preliminary Investigation of Needle Bearings of  $1\frac{1}{8}$ -Inch Pitch Diameter at Speeds to 17,000 rpm. NACA TN 1920, 1949.
7. Jakob, Max: Heat Transfer. Vol. 1. John Wiley & Sons, Inc., 1949, pp. 543-566.
8. Buckingham, E.: On Physically Similar Systems; Illustrations of the Use of Dimensional Equations. Phys. Rev., vol. IV, no. 4, 2d ser., Oct. 1914, pp. 345-376.
9. Scott, G. S., Jones, G. W., and Scott, F. E.: Determination of Ignition Temperatures of Combustible Liquids and Gases. Anal. Chem., vol. 20, no. 3, March 1948, pp. 238-241.



TABLE I - PHYSICAL CHARACTERISTICS OF TEST BEARINGS

Bearing number	8		6		5		10	
	One-piece inner-race-riding cage	One-piece inner-race-riding cage	One-piece inner-race-riding cage	One-piece inner-race-riding cage	Two-piece inner-race-riding cage	Two-piece inner-race-riding cage	One-piece inner-race-riding cage	One-piece inner-race-riding cage
Number of rollers	17	18	17	18	17	17	18	18
Roller $\frac{L}{d}$ ratio	1	1	1	1	1	1	1	1
Pitch diameter of bearing (in.)	4.036		4.036		4.031		4.036	
Total running time, (hr)	Before	After	Before	After	Before	After	Before	After
	0	38.6	0	195.9	0	133.5	0	86.8
$\Delta T$ temperature, ( $^{\circ}F$ ) multiplied by time (min)	0	$3.22 \times 10^5$	0	$11.64 \times 10^5$	0	$11.79 \times 10^5$	0	$3.22 \times 10^5$
Roller diameter, (in.)	$b_0.5513$	0.5509	$b_0.5513$	0.5510	$b_0.5625$	0.5624	$b_0.5513$	-----
Roller length, (in.)	$b_0.5510$	0.5509	$b_0.5510$	0.5507	$b_0.5625$	0.5625	$b_0.5510$	-----
Diametral clearance between cage and roller, (in.)	$b_0.0087$	0.0076	$b_0.0087$	0.010	$b_0.0097$	0.0082	$b_0.0087$	-----
Axial clearance between roller and inner-race flange, (in.)	$b_0.002$	0.002	$b_0.002$	0.002	$b_0.003$	0.005	$b_0.002$	-----
Axial clearance between roller and cage, (in.)	$b_0.006$	0.006	$b_0.007$	0.009	$b_0.011$	0.011	$b_0.006$	-----
Unmounted bearing:								
<sup>c</sup> Diametral clearance, (in.)	0.0018	0.0019	0.0020	0.0022	0.0018	$f_0.0015$	0.0018	-----
Bearing	.021	.021	.015	.018	.011	.012	.013	-----
Cage	.0000	.0002	.0000	.0002	.0001	.0001	.0001	-----
<sup>d</sup> Eccentricity, (in.)								
Mounted bearing:								
<sup>e</sup> Diametral clearance, (in.)	0.0005	0.0005	0.0009	0.0009	0.0005	$f_0.0002$	0.0007	0.0008
Bearing	.019	.022	.014	.017	.010	.011	0.013	-----
Cage	.0004	.0005	.0005	.0004	.0005	-----	-----	.0006
<sup>e</sup> Eccentricity, (in.)								
Remarks	Satisfactory operation	Satisfactory operation	Satisfactory operation	Satisfactory operation	Unusually hot operation but no failure	Unusually hot operation but no failure	Satisfactory operation. Shut off oil and ran bearing to incipient failure	Satisfactory operation. Shut off oil and ran bearing to incipient failure

<sup>a</sup>Severity factor. (Severity factor is summation of products of difference between equilibrium bearing temperature and oil inlet temperature for each operating condition and corresponding operating time in min at that particular condition.)

<sup>b</sup>Measurements obtained from sample bearing.

<sup>c</sup>Measurement obtained in fixture with dial gage.

<sup>d</sup>Measurement obtained in fixture with dial gage, inner race rotating and outer race stationary.

<sup>e</sup>Measurements obtained as mounted in test rig with dial gage.

<sup>f</sup>Diametral clearance actually decreased due to apparent growth of inner race.

<sup>g</sup>Measurements obtained as mounted in test rig with dial gage, inner race rotating and outer race stationary.

TABLE II - VOLATILITY DATA FOR OIL AS DETERMINED  
IN MOORE TYPE APPARATUS

[Number of drops used, 2.]

Temperature (°F)	Time lag before ignition (min)	Remarks
100	(a)	(b)
125	(a)	(b)
150	(a)	(b)
175	(a)	(b)
200	(a)	(b)
225	(a)	(b)
250	(a)	(c)
275	(a)	(d)
300	(a)	(d)
310	(a)	(d)
350	(a)	(d)
390	(a)	(e)
430	(a)	(e)
468	(a)	(e)
477	(a)	(e)
484	(a)	(e)
490	1.010	(f)
498	.721	(f)
500	.532	(f)
506	.512	(f)
509	0.402	(f)
516	.340	(f)
522	.280	(f)
528	.190	(f)
544	.170	(f)



<sup>a</sup>Greater than 2 minutes.

<sup>b</sup>No evidence of oxidation.

<sup>c</sup>Slight wisps of white smoke - no residue.

<sup>d</sup>Heavier wisps of white smoke - no residue.

<sup>e</sup>Bluish white smoke - residue forming.

<sup>f</sup>Ignition - light residue forming.



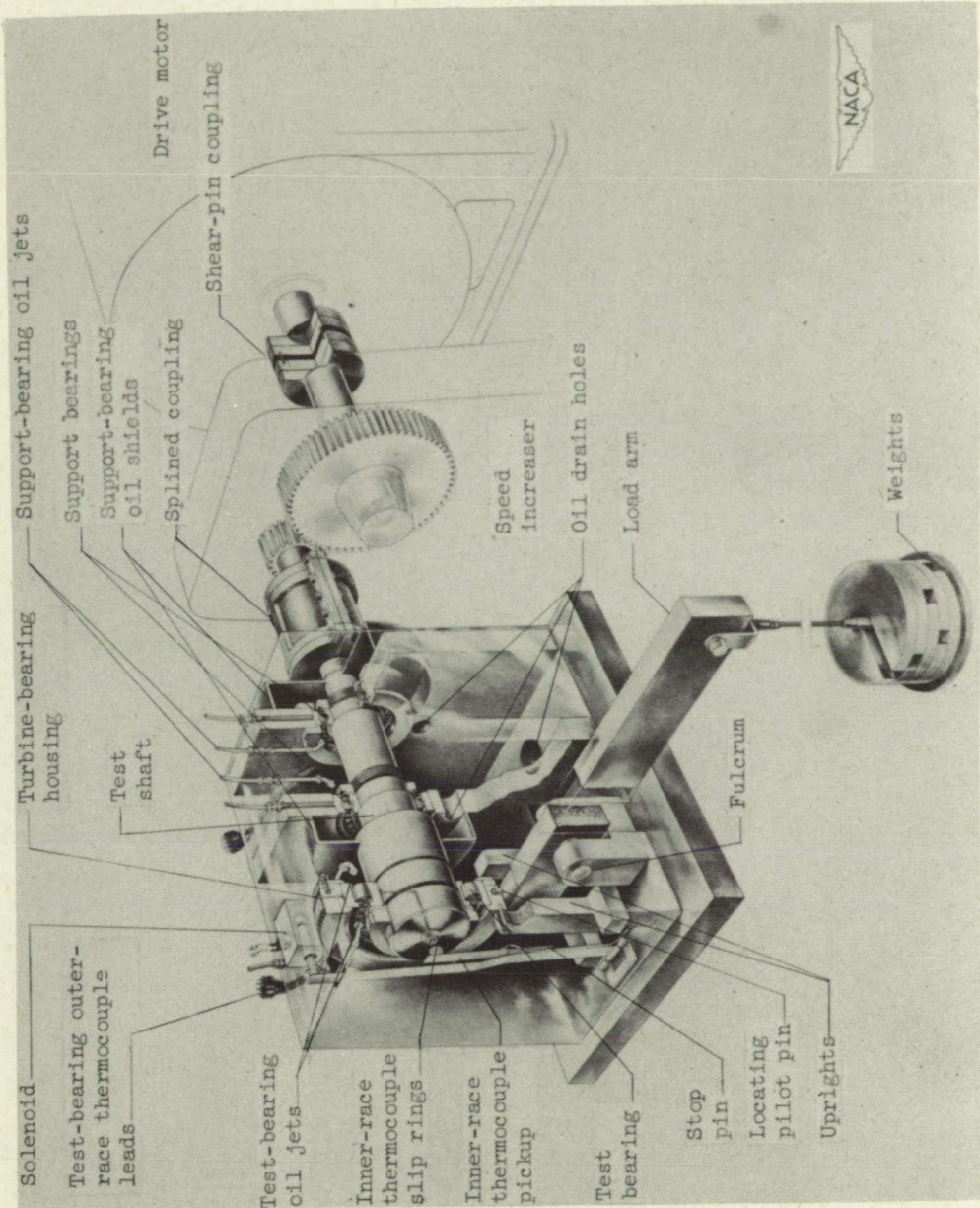
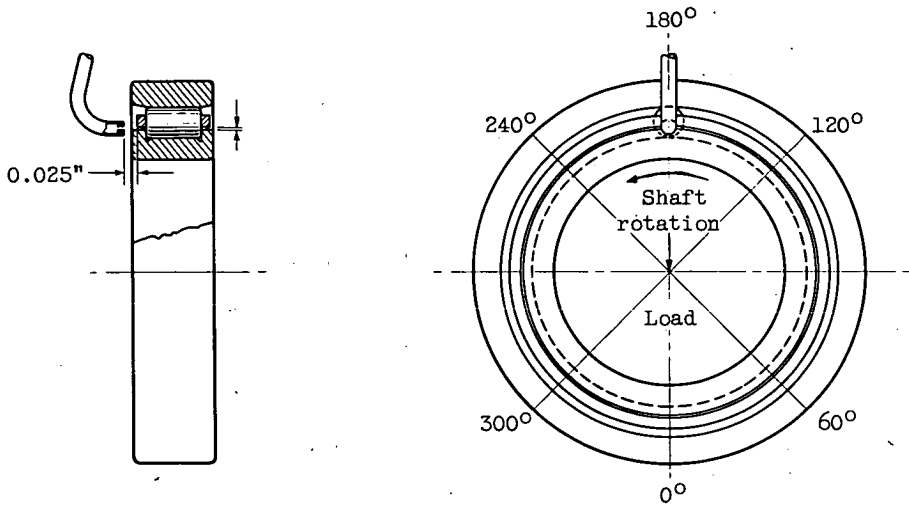
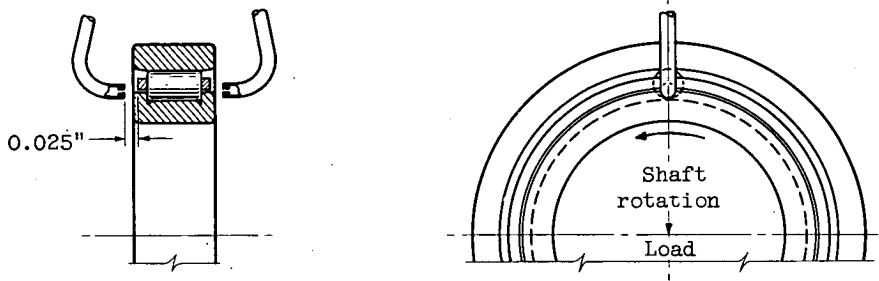

Figure 1. - Cutaway view of radial-load rig.



(a) Single jet.



(b) Single-opposed jets.

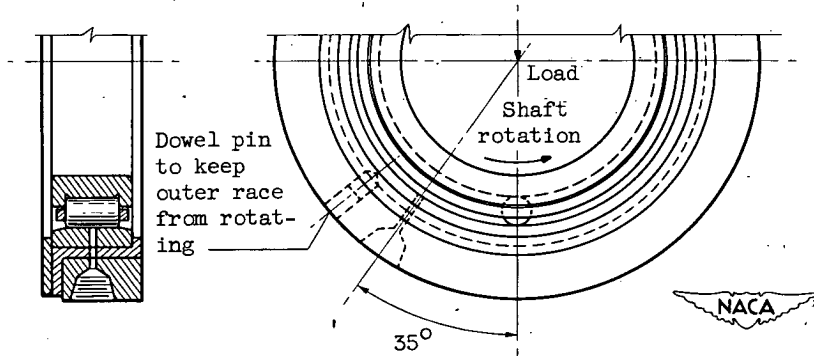

(c) Outer-race radial hole (diam. of orifice, 0.089 in.).

Figure 2. - Methods of introducing oil to test bearing.

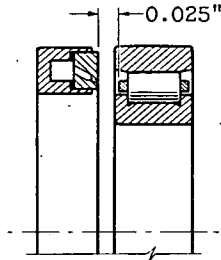

(d) Multiple jets from circular manifold (12 orifices, each 0.024 inch diam.).

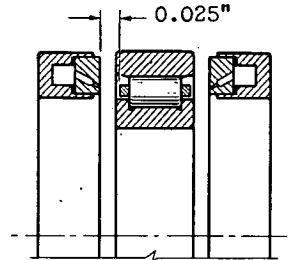

(e) Multiple-opposed jets from circular manifold (12 orifices each side, each 0.024 inch diam.).

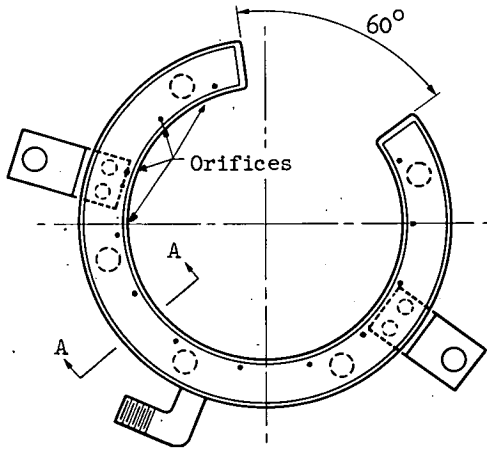

(f) Mounting arrangement of circular manifold for multiple jet arrangements (figs. 2(d) and 2(e)).

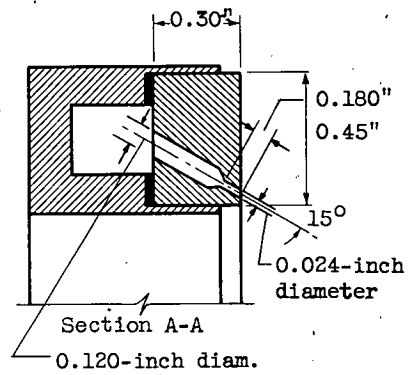

(g) Construction of circular manifold.

Figure 2. - Concluded: Methods of introducing oil to test bearing.

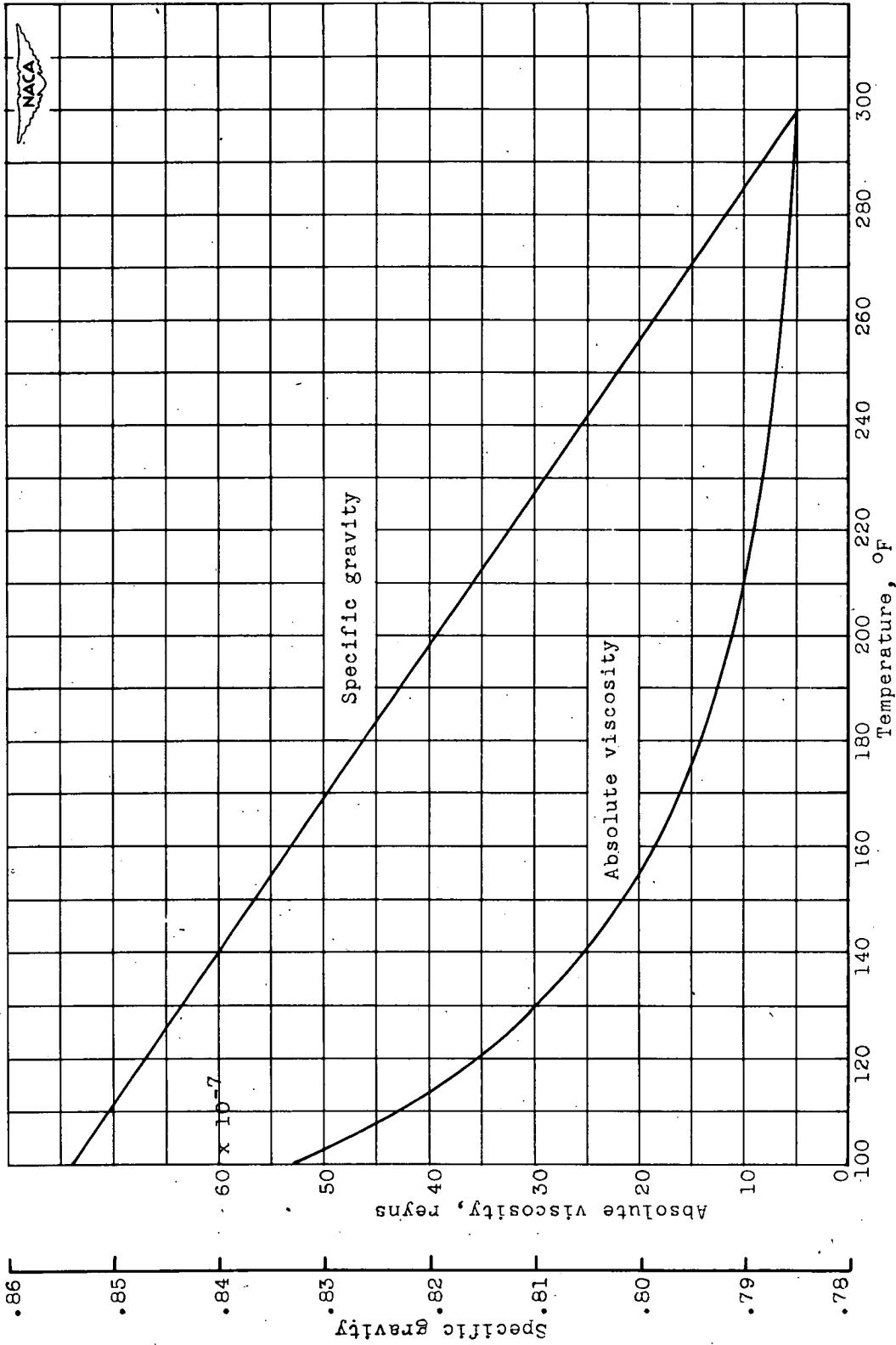

Figure 3. - Absolute viscosity and specific gravity of lubricant. Pour point, -50° F; flash point, 310° F, viscosity index, 150.

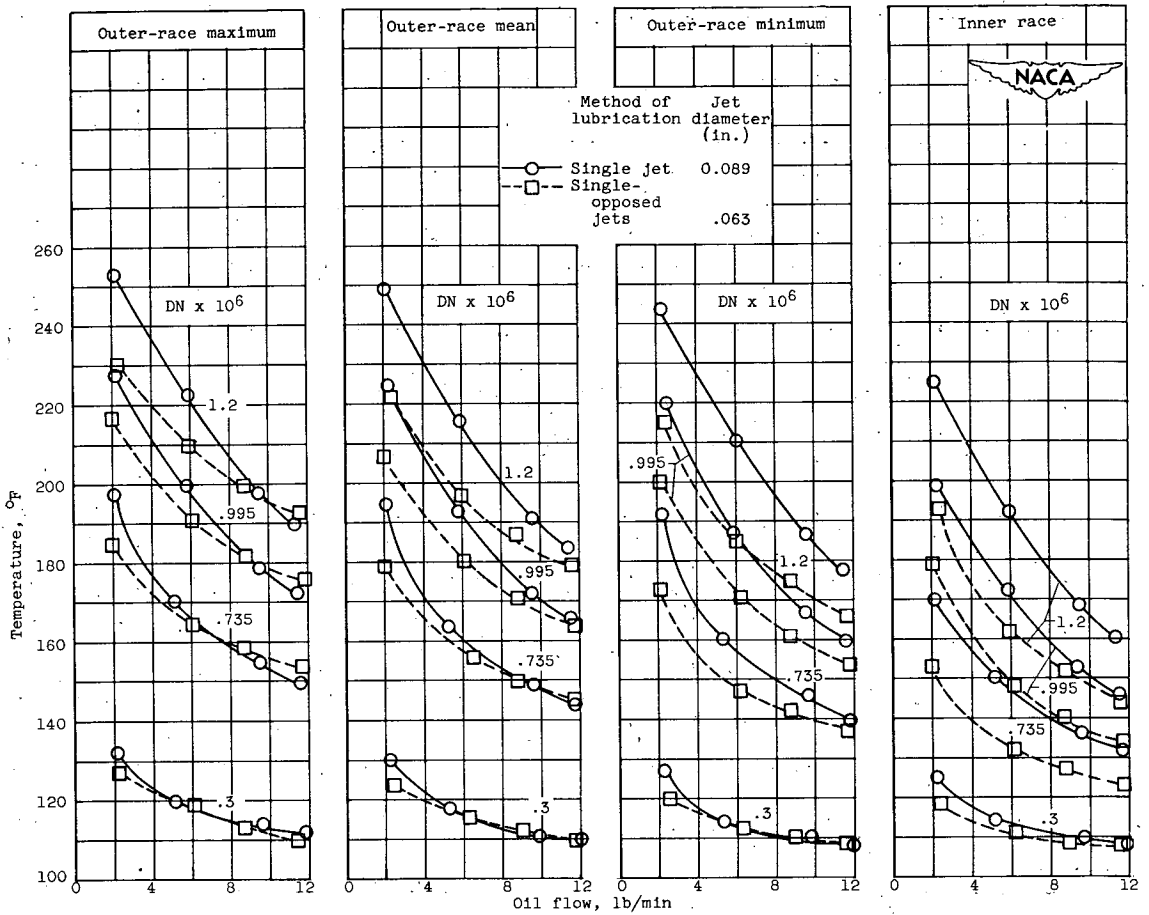

Figure 4. - Effect of oil flow on outer-race maximum, mean, and minimum and inner-race temperatures of bearing 6 for comparison of two methods of lubrication over range of DN values. Oil flow, 2 to 12 pounds per minute; methods of lubrication, single-jet and single-opposed jets; DN,  $0.3 \times 10^6$  to  $1.2 \times 10^6$ ; oil inlet temperature, 100° F; load, 368 pounds.

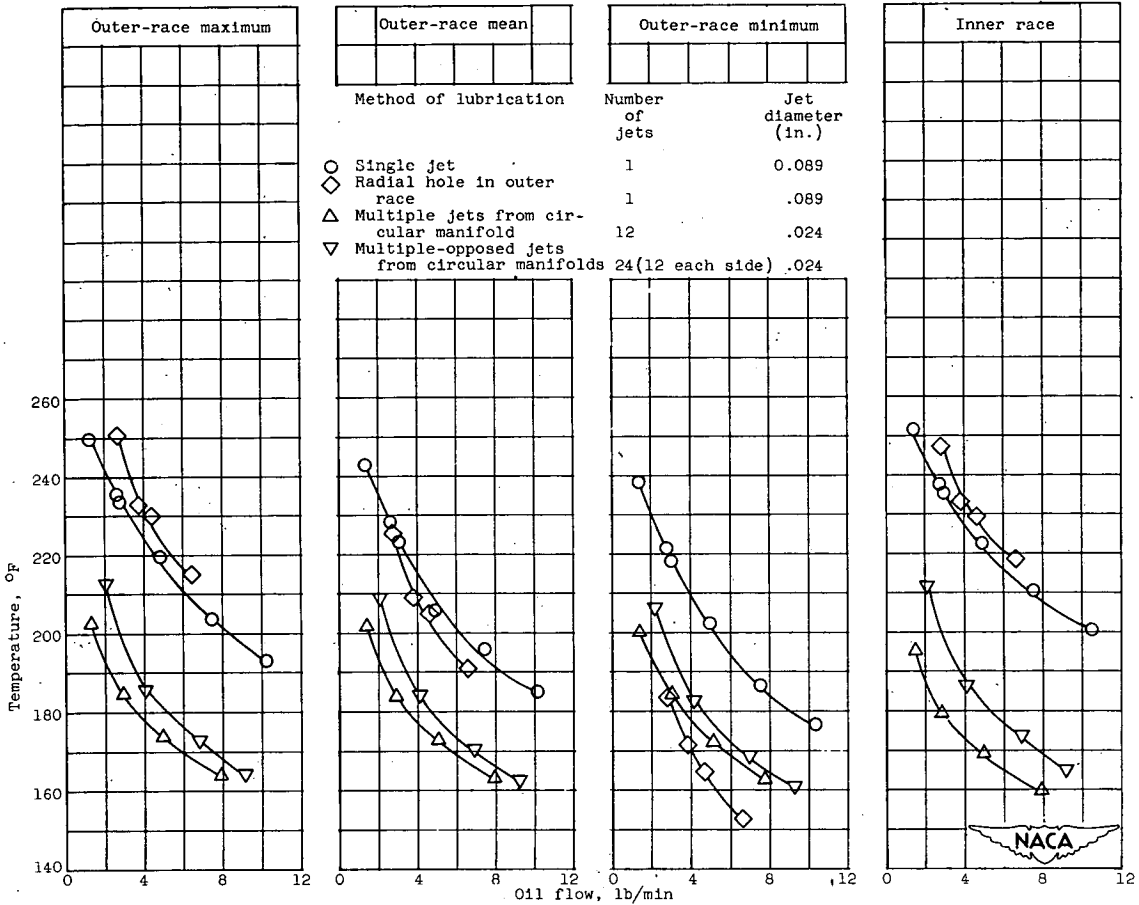
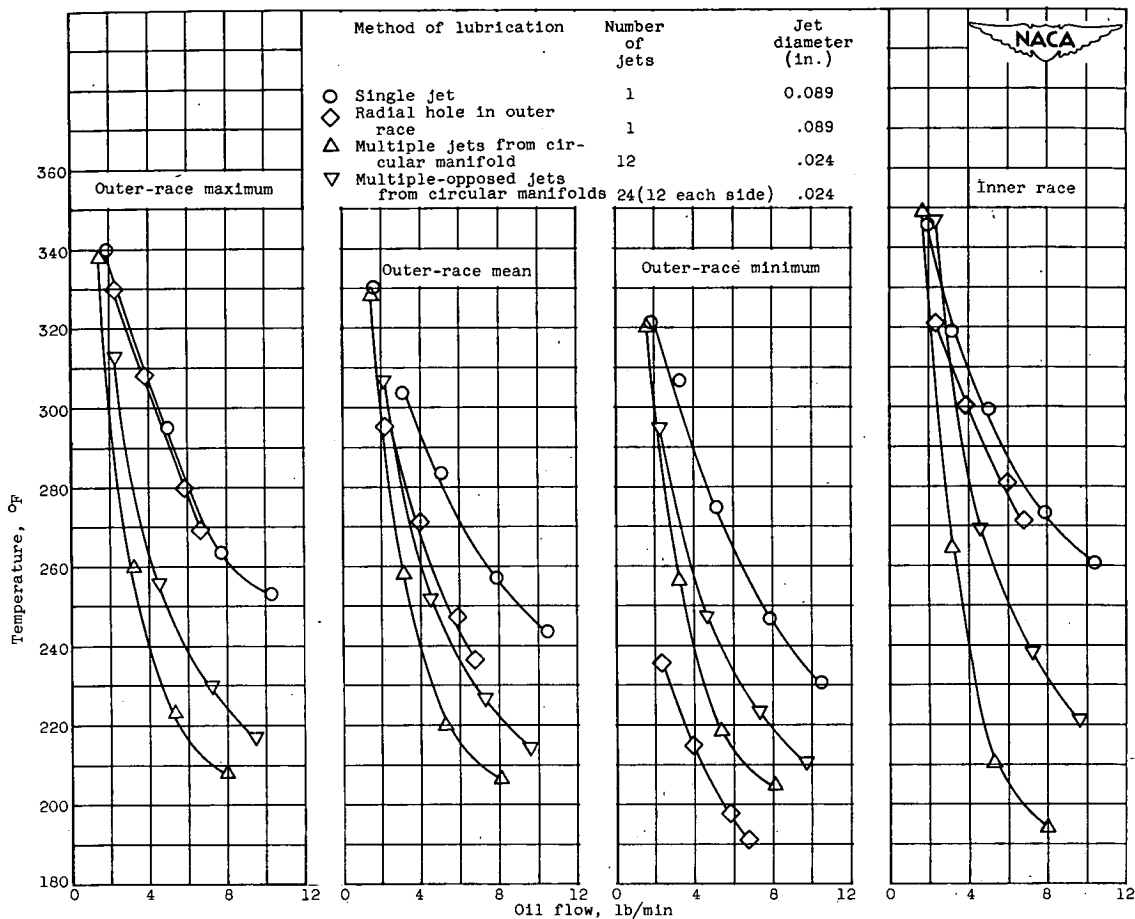
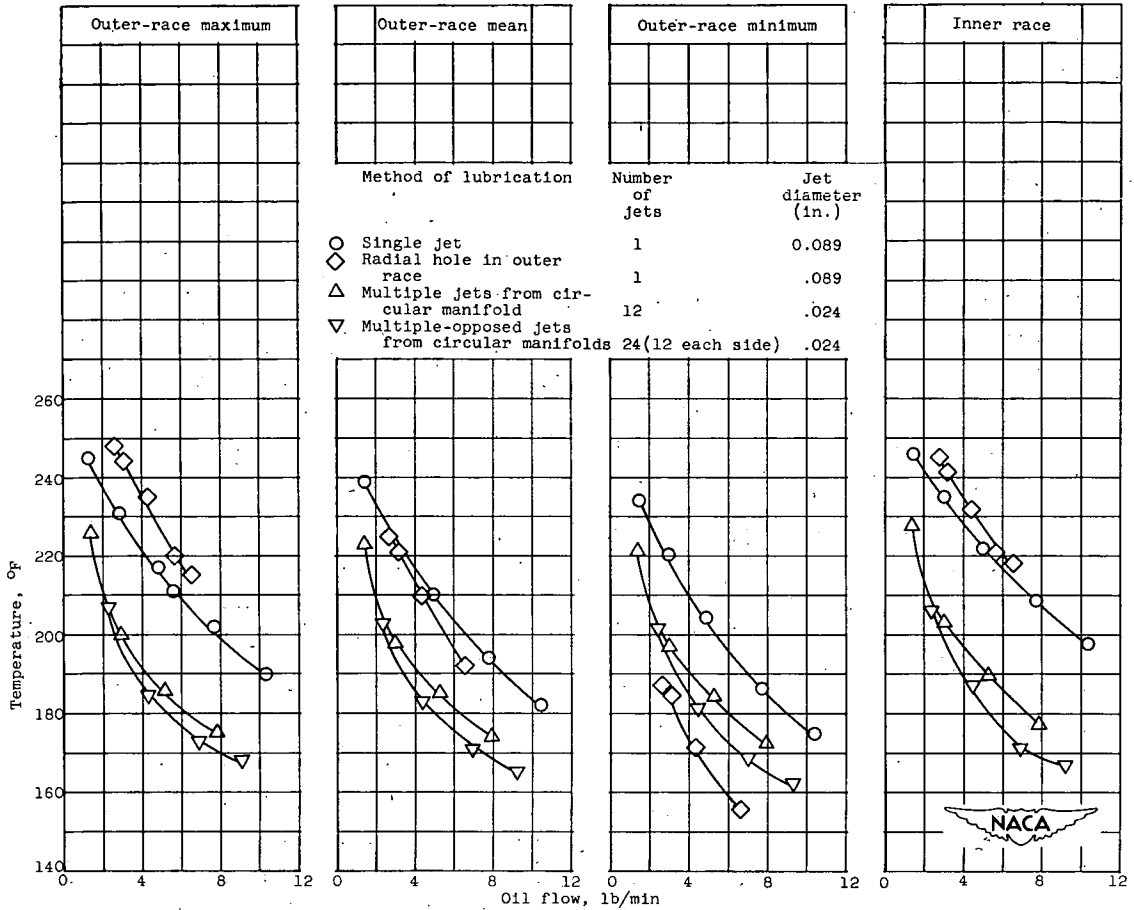

Figure 5. - Effect of oil flow on outer-race maximum, mean, and minimum and inner-race temperatures of bearing 5 for four methods of lubrication at various DN values and loads. Oil flow, 1.5 to 10.3 pounds per minute; methods of lubrication, single jet, radial hole in outer race, multiple jets from circular manifold, and multiple-opposed jets from circular manifolds; oil inlet temperature, 100° F.



(b) DN,  $1.2 \times 10^6$ ; load, 7 pounds.

Figure 5. - Continued. Effect of oil flow on outer-race maximum, mean, and minimum and inner-race temperatures of bearing 5 for four methods of lubrication at various DN values and loads. Oil flow, 1.5 to 10.3 pounds per minute; methods of lubrication, single jet, radial hole in outer race, multiple jets from circular manifold, and multiple-opposed jets from circular manifolds; oil inlet temperature,  $100^\circ\text{F}$ .



(c) DN,  $0.735 \times 10^6$ , load, 368 pounds.

Figure 5. - Continued. Effect of oil flow on outer-race maximum, mean, and minimum and inner-race temperatures of bearing 5 for four methods of lubrication at various DN values and loads. Oil flow, 1.5 to 10.3 pounds per minute; methods of lubrication, single jet, radial hole in outer race, multiple jets from circular manifold, and multiple-opposed jets from circular manifolds; oil inlet temperature, 100° F.



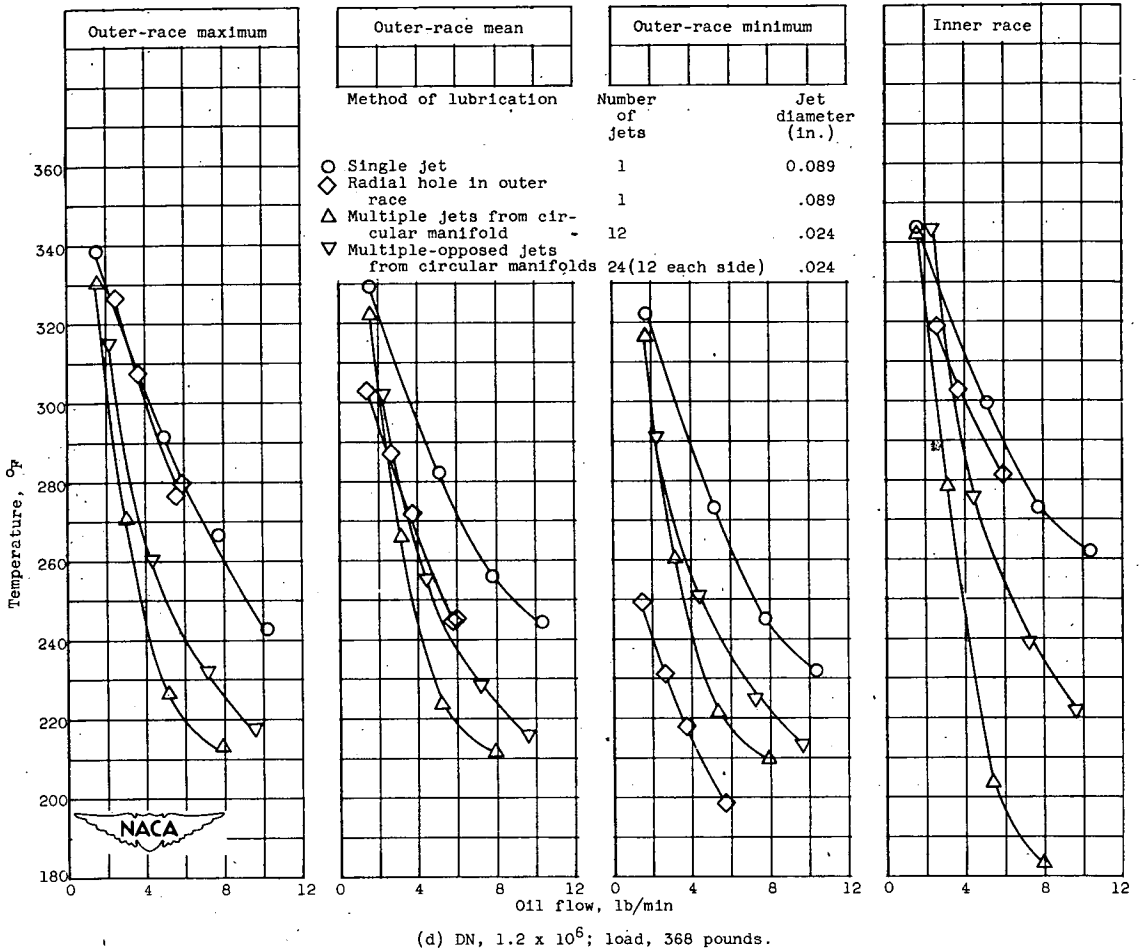

Figure 5. - Concluded. Effect of oil flow on outer-race maximum, mean, and minimum and inner-race temperatures of bearing 5 for four methods of lubrication at various DN values and loads. Oil flow, 1.5 to 10.3 pounds per minute; methods of lubrication, single jet, radial hole in outer race, multiple jets from circular manifold, and multiple-opposed jets from circular manifolds; oil inlet temperature, 100° F.

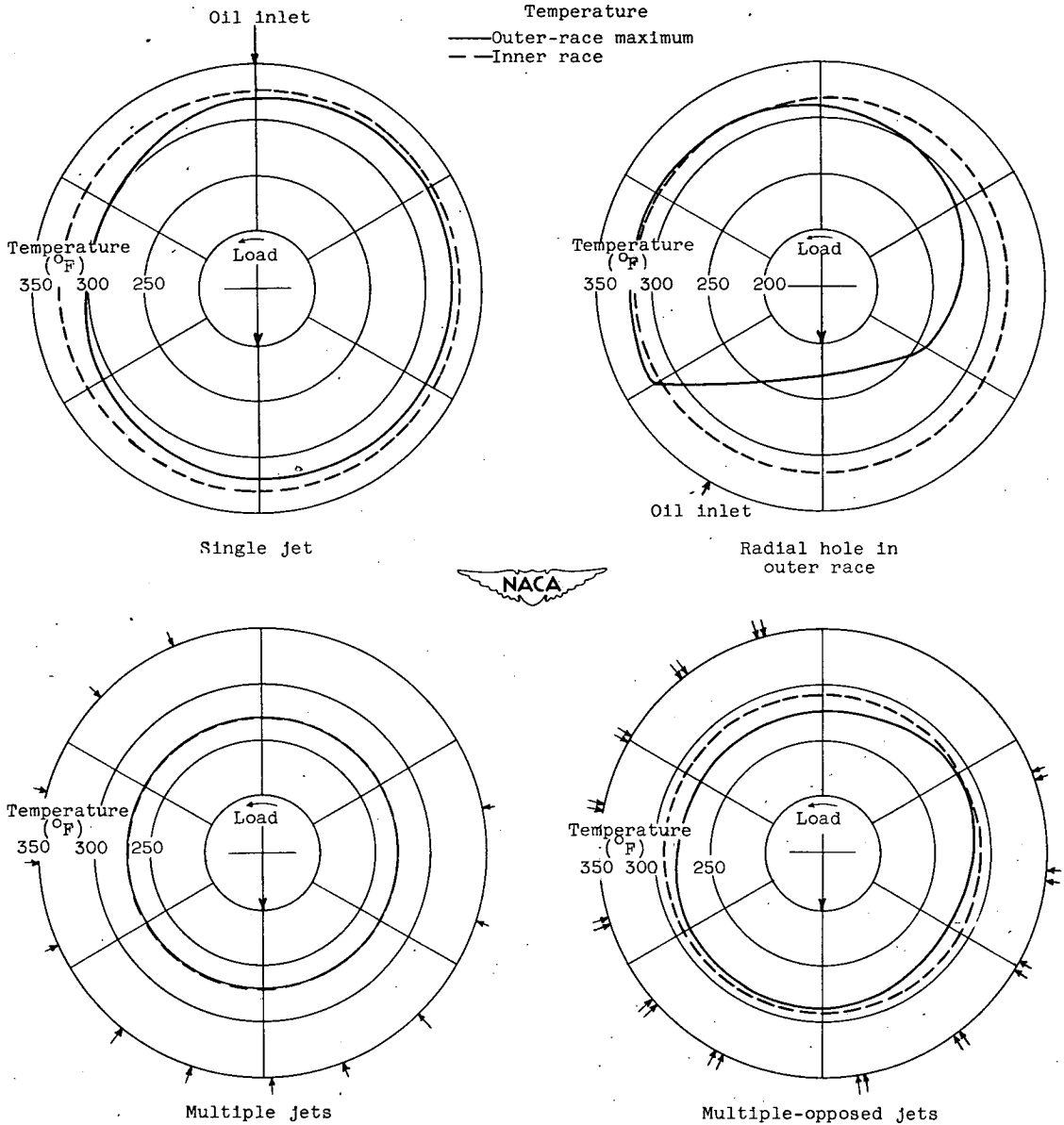
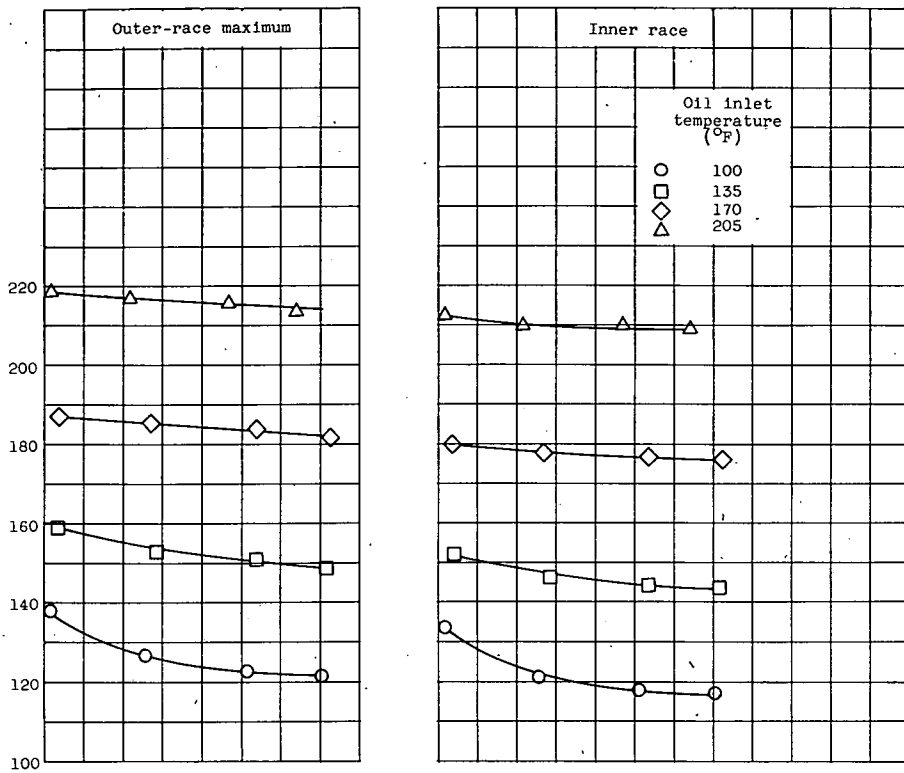
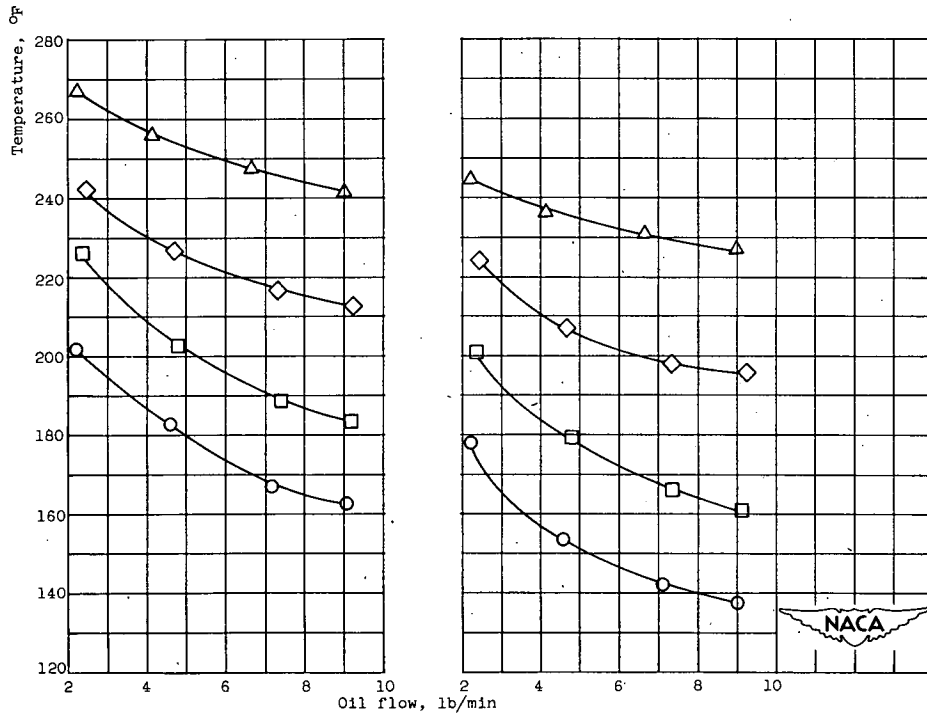

Figure 6. - Effect of oil distribution on circumferential temperature distribution of bearing 5 for four methods of lubrication. Methods of lubrication, single jet, radial hole in outer race, multiple jets, and multiple-opposed jets; DN,  $1.2 \times 10^6$ ; oil inlet temperature,  $100^\circ$  F; oil flow, 2.8 pounds per minute; load, 368 pounds.



(a) DN,  $0.3 \times 10^6$ .



(b) DN,  $0.735 \times 10^6$ .

Figure 7. - Effect of oil flow on outer-race maximum and inner-race temperatures of bearing 10 for various oil inlet temperatures and DN values. Oil flow, 2.2 to 9.3 pounds per minute; oil inlet temperatures, 100°, 135°, 170°, and 205° F; oil-jet diameter, 0.050 inch; load, 368 pounds.



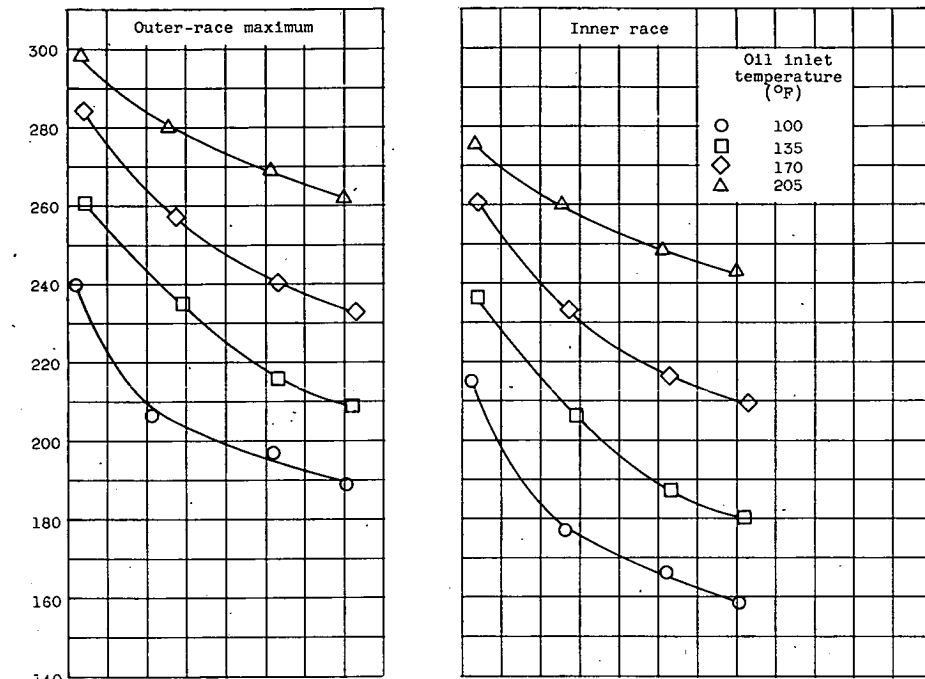

(c) DN,  $0.995 \times 10^6$ .

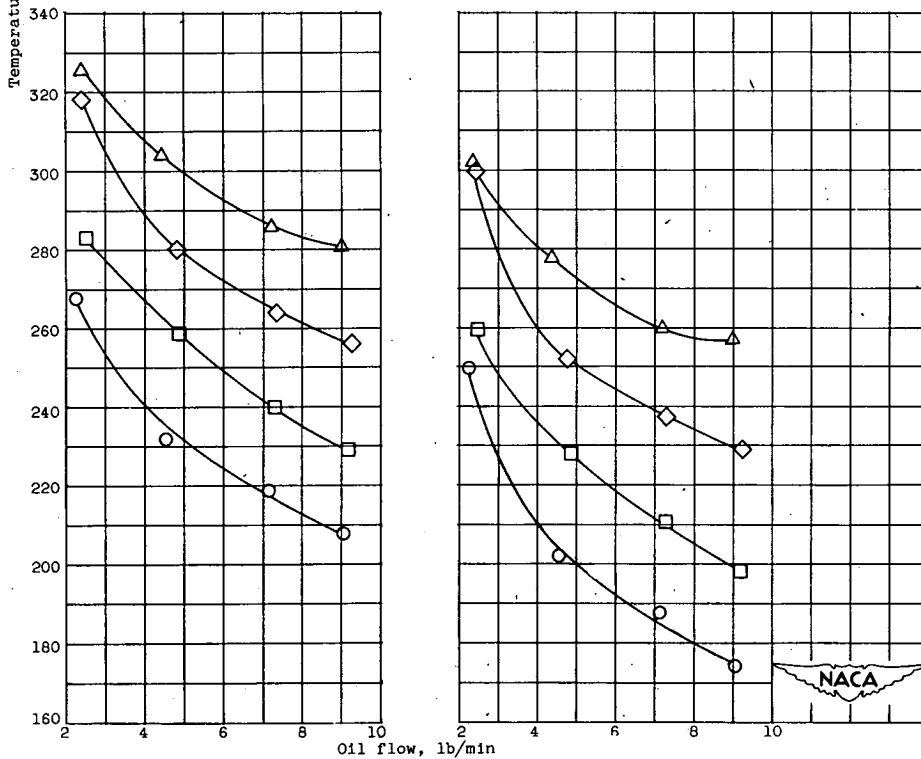

(d) DN,  $1.2 \times 10^6$ .

Figure 7. - Concluded. Effect of oil flow on outer-race maximum and inner-race temperatures of bearing 10 for various oil inlet temperatures and DN values. Oil flow, 2.2 to 9.3 pounds per minute; oil inlet temperature, 100°, 135°, 170°, and 205° F; oil-jet diameter, 0.050 inch; load, 368 pounds.



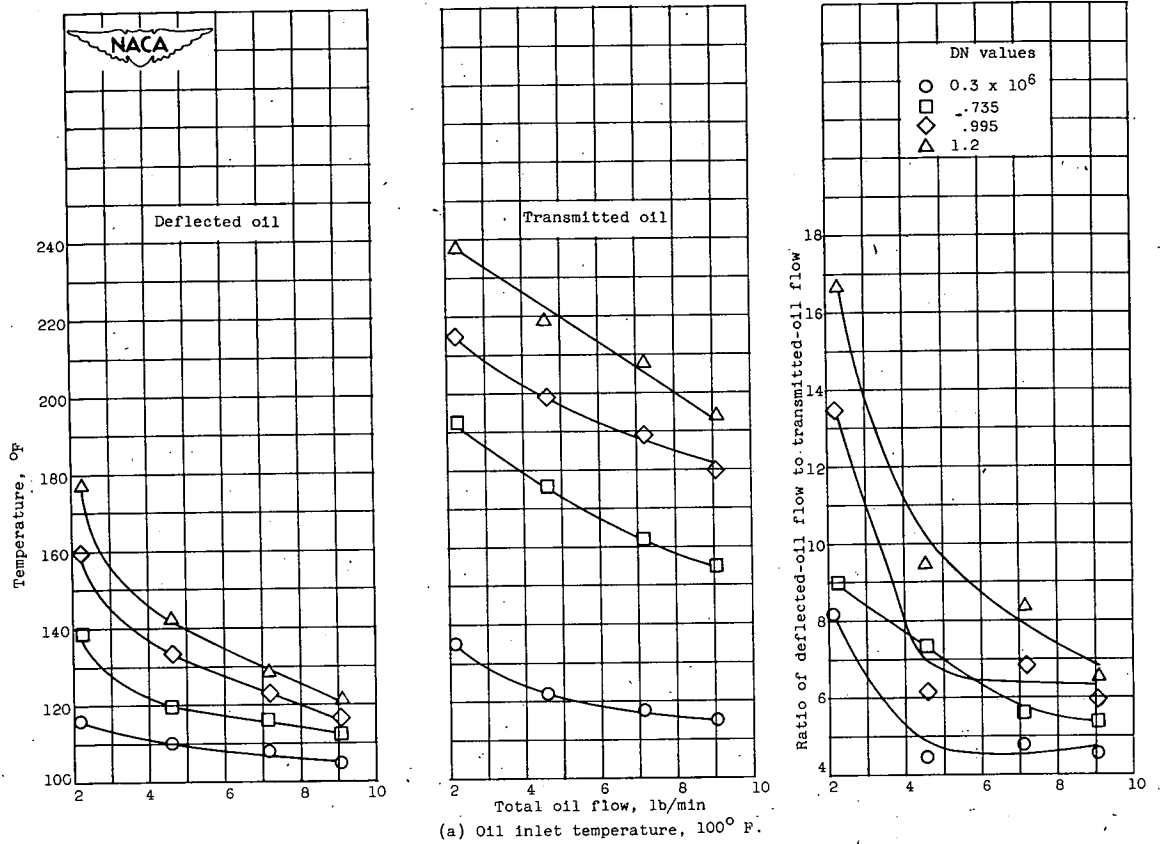

Figure 8. - Effect of oil flow on deflected- and transmitted-oil temperatures of bearing 10 for various DN values and oil inlet temperatures. Oil flow, 2.2 to 9.3 pounds per minute; DN,  $0.3 \times 10^6$  to  $1.2 \times 10^6$ ; oil-jet diameter, 0.050 inch; load, 368 pounds.

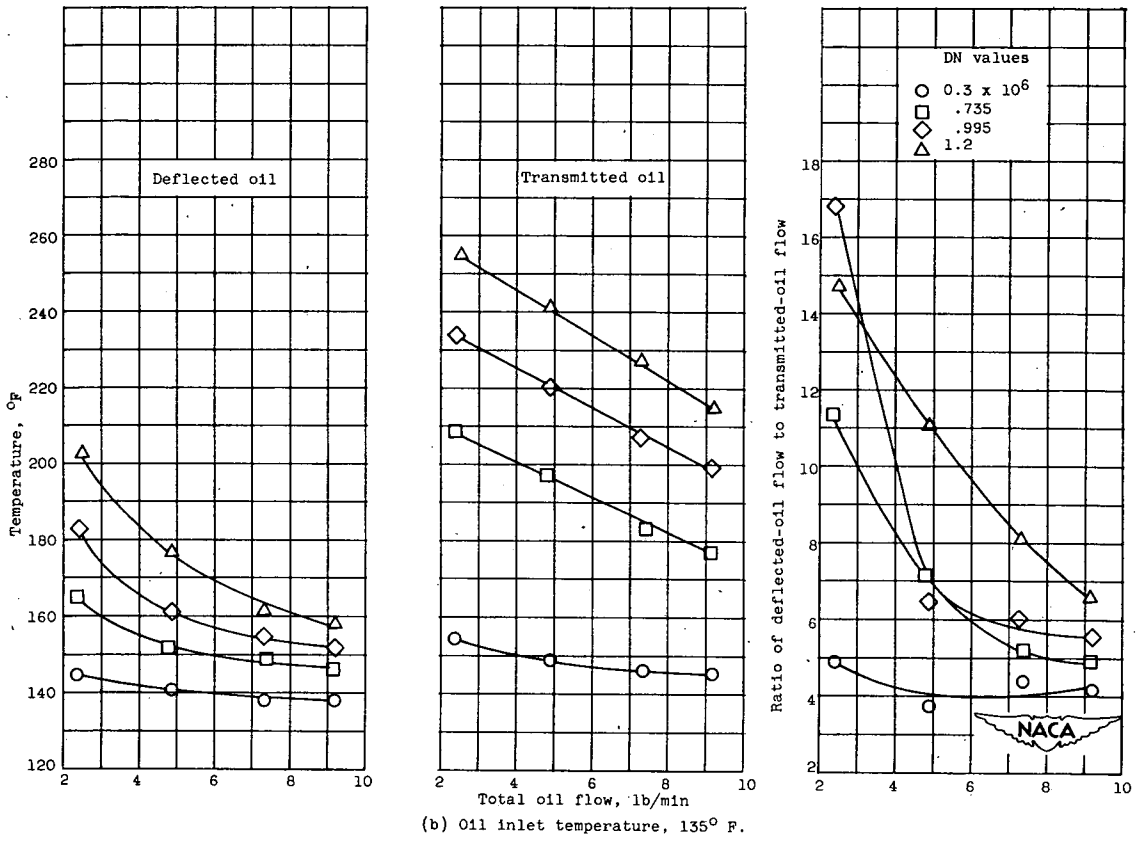

Figure 8. - Continued. Effect of oil flow on deflected- and transmitted-oil temperatures of bearing 10 for various DN values and oil inlet temperatures. Oil flow, 2.2 to 9.3 pounds per minute; DN,  $0.3 \times 10^6$  to  $1.2 \times 10^6$ ; oil-jet diameter, 0.050 inch; load, 368 pounds.

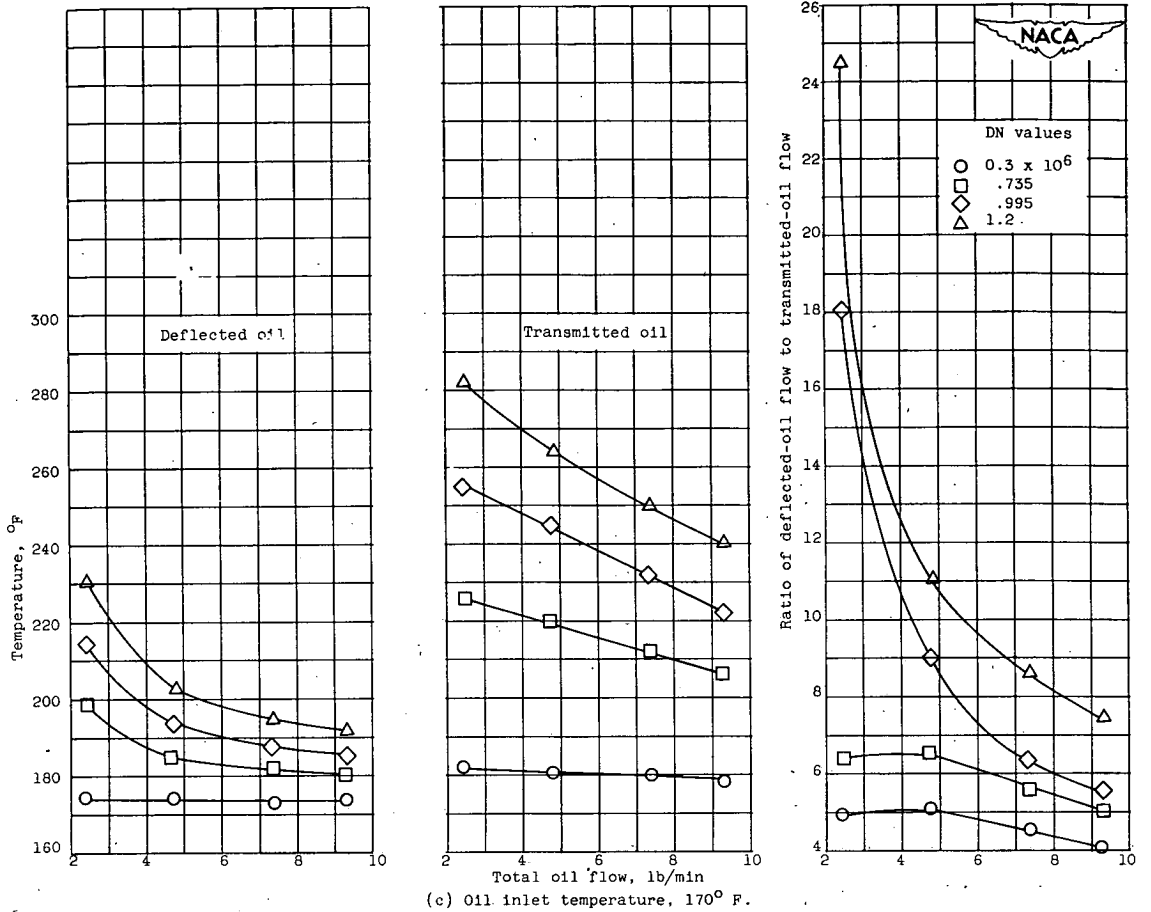
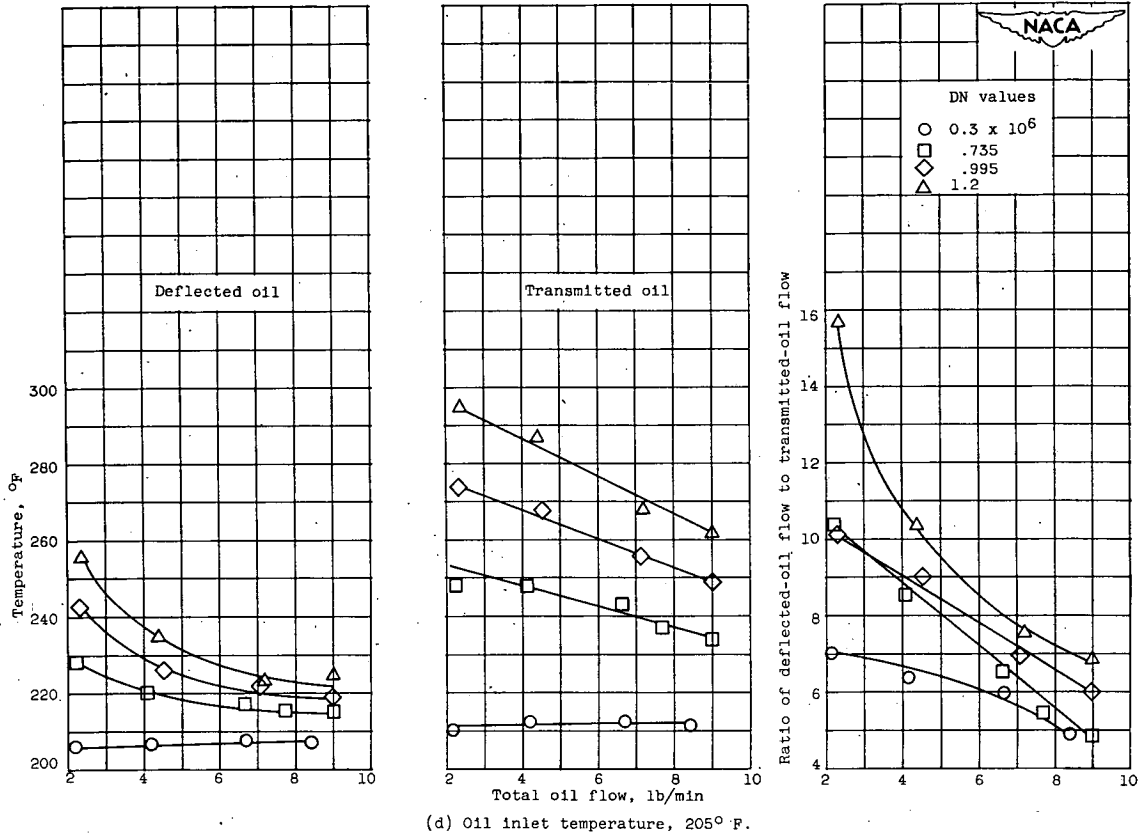

Figure 8. - Continued. Effect of oil flow on deflected- and transmitted-oil temperatures of bearing 10 for various DN values and oil inlet temperatures. Oil flow, 2.2 to 9.3 pounds per minute; DN,  $0.3 \times 10^6$  to  $1.2 \times 10^6$ ; oil-jet diameter, 0.050 inch; load, 368 pounds.



(d) Oil inlet temperature, 205° F.

Figure 8. - Concluded. Effect of oil flow on deflected- and transmitted-oil temperatures of bearing 10 for various DN values and oil inlet temperatures. Oil flow, 2.2 to 9.3 pounds per minute; DN, 0.3 x 10<sup>6</sup> to 1.2 x 10<sup>6</sup>; oil-jet diameter, 0.050 inch; load, 368 pounds.



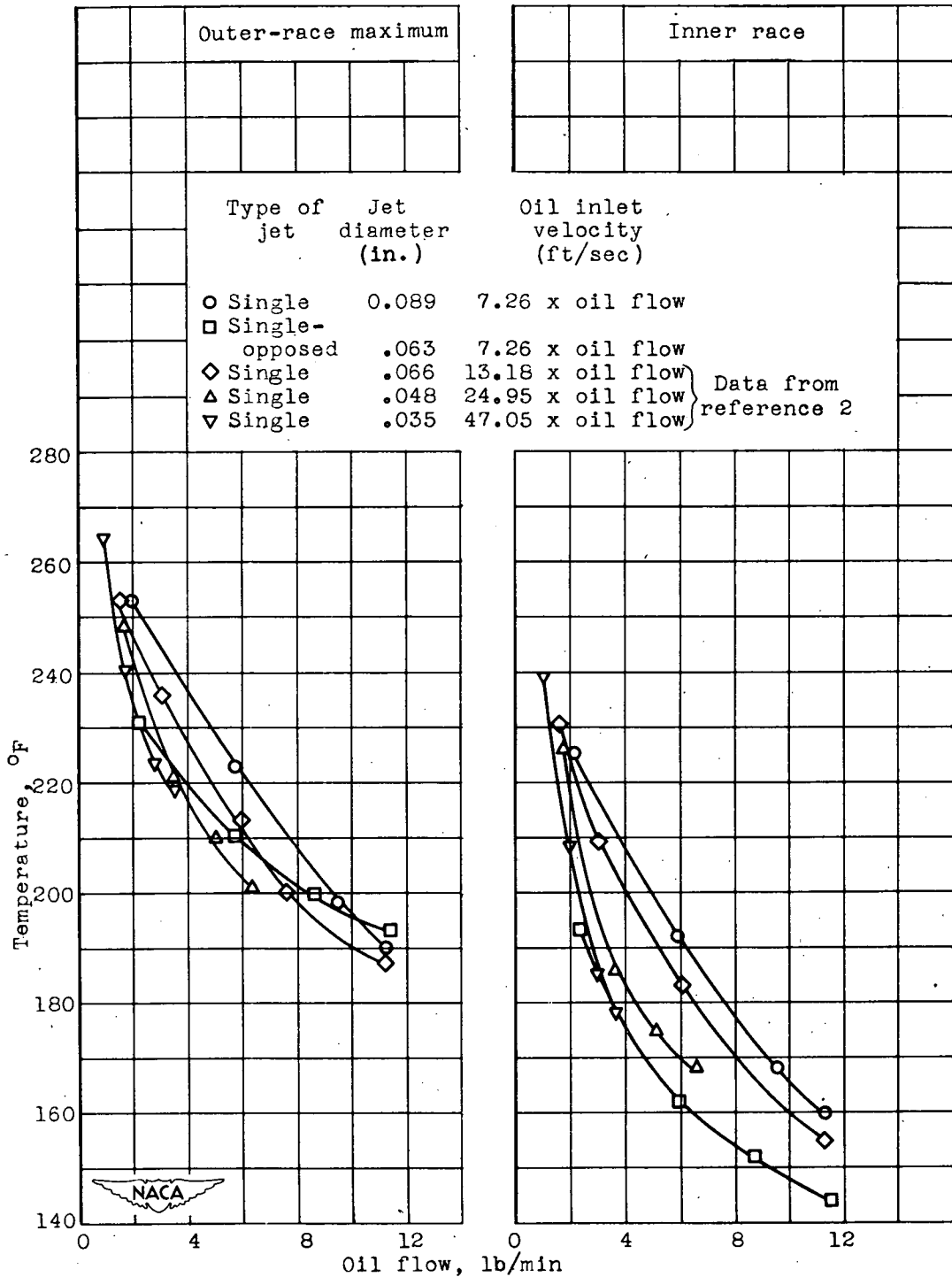

Figure 9. - Effect of oil flow on outer-race-maximum and inner-race temperatures of bearing 6 for single-opposed jets and single jets of various sizes. Oil flow, 1.2 to 11.5 pounds per minute; DN,  $1.2 \times 10^6$ ; oil inlet temperature,  $100^\circ\text{F}$ ; load, 368 pounds.

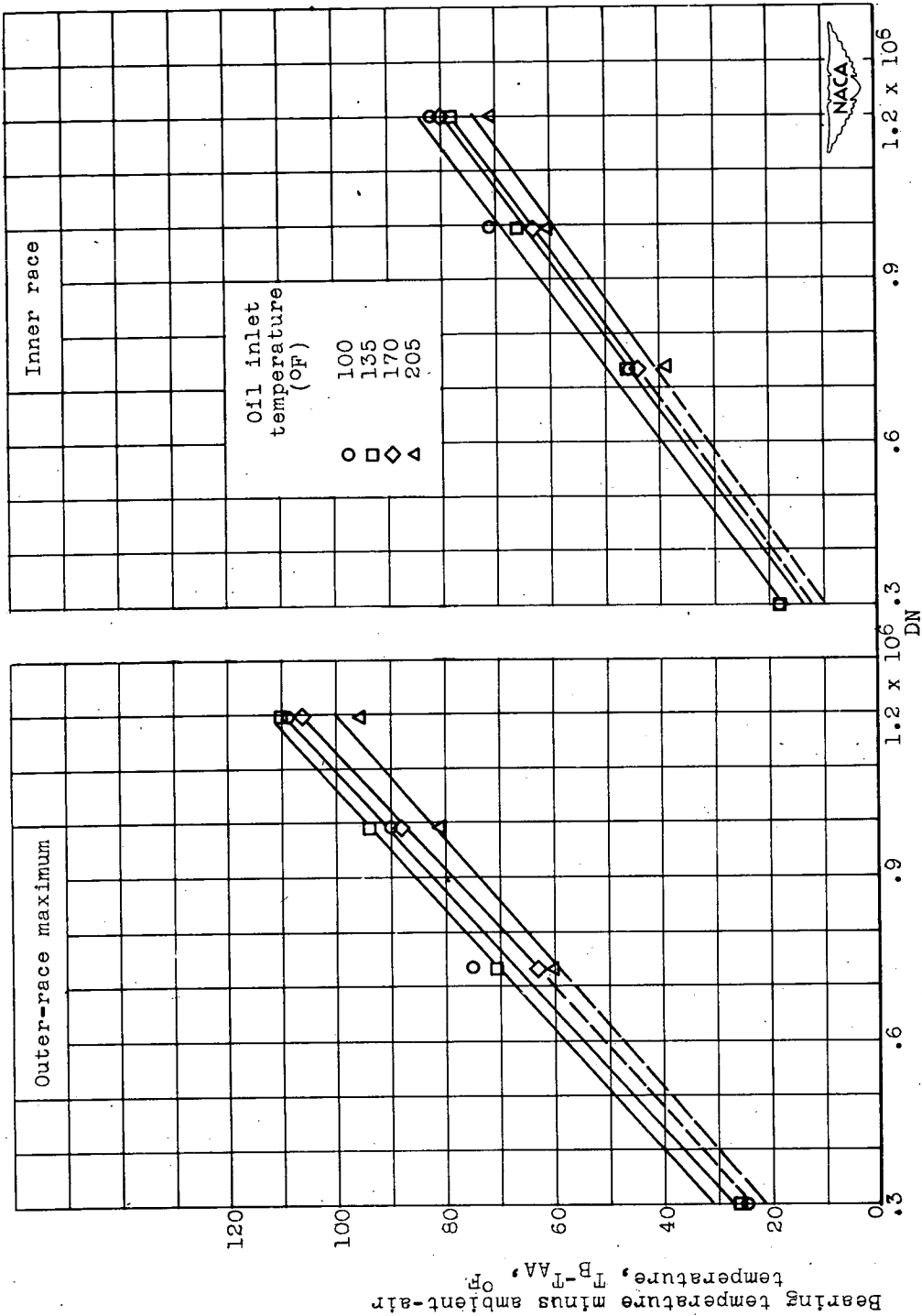

Figure 10. - Effect of DN on difference between bearing temperature and ambient-air temperature of bearing 10 for various oil inlet temperatures. DN, 0.3 x 10<sup>6</sup> to 1.2 x 10<sup>6</sup>; oil inlet temperature, 100°, 135°, 170°, 205° F; oil flow, 4 pounds per minute; oil-jet diameter, 0.050 inch; load, 368 pounds.

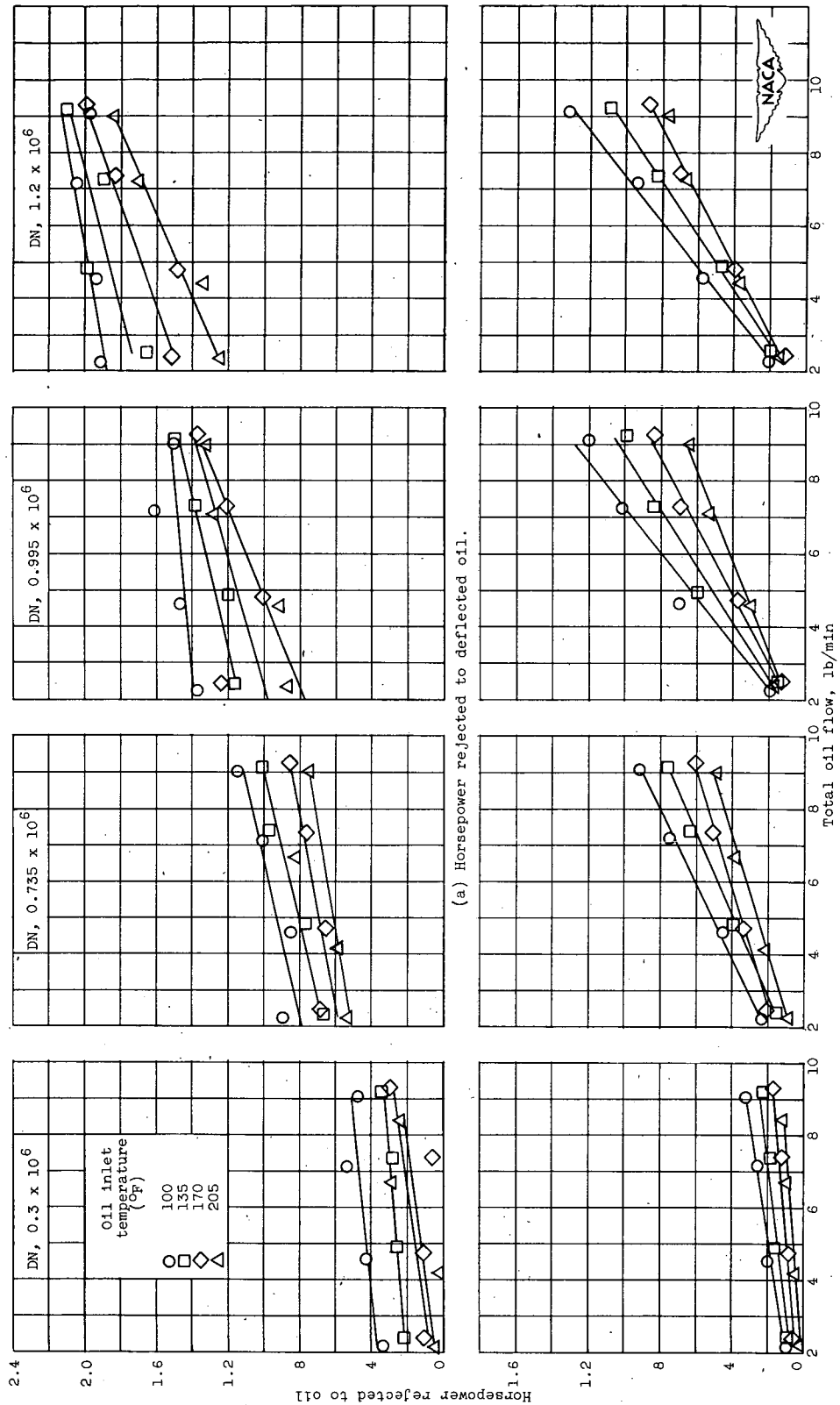
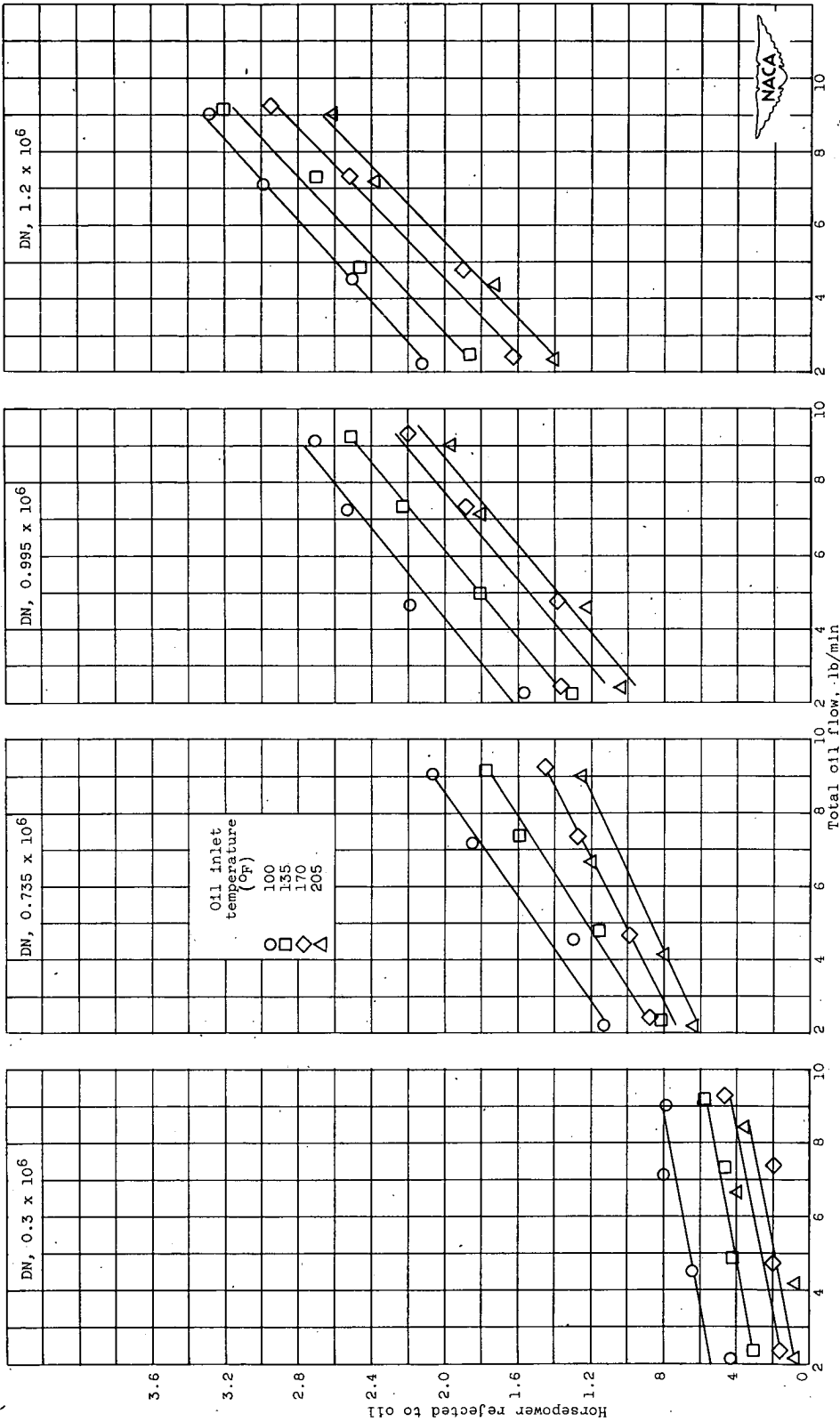

Fig. 11. - Effect of oil flow on horsepower rejected to oil of bearing 10 for various oil inlet temperatures and DN values. Oil flow, 2.2 to 9.1 pounds per minute; oil inlet temperature, 100°, 135°, 170°, and 205° F; DN, 0.3 x 10<sup>6</sup> to 1.2 x 10<sup>6</sup>; oil-jet diameter, 0.050 inch; I<sub>oa</sub>, 368 pounds.



(c) Total horsepower rejected to oil.

Figure 11. - Concluded. Effect of oil flow on horsepower rejected to oil of bearing 10 for various oil inlet temperatures and DN values. Oil flow, 2.2 to 9.3 pounds per minute; oil inlet temperature, 100°, 135°, 170°, and 205° F; DN, 0.3 x 10<sup>6</sup> to 1.2 x 10<sup>6</sup>; oil-jet diameter, 0.050 inch; load, 368 pounds.

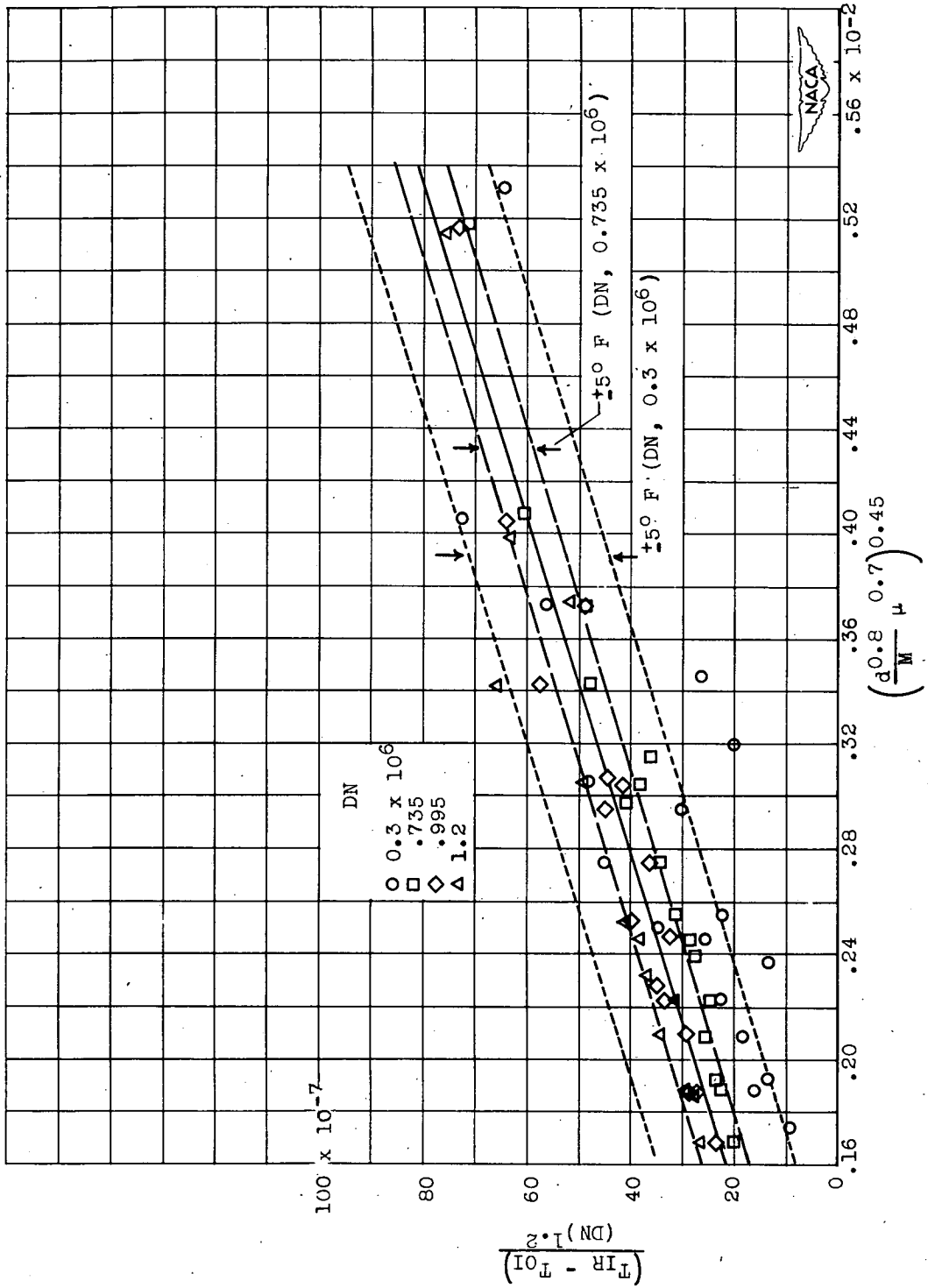

Figure 12. - Cooling-correlation curve for inner-race temperature of bearing 10. (Temperature, °F; DN, bearing bore in mm times shaft speed in rpm; viscosity, lb-sec/sq in.; oil-jet diameter, in.; oil flow, lb/min.)

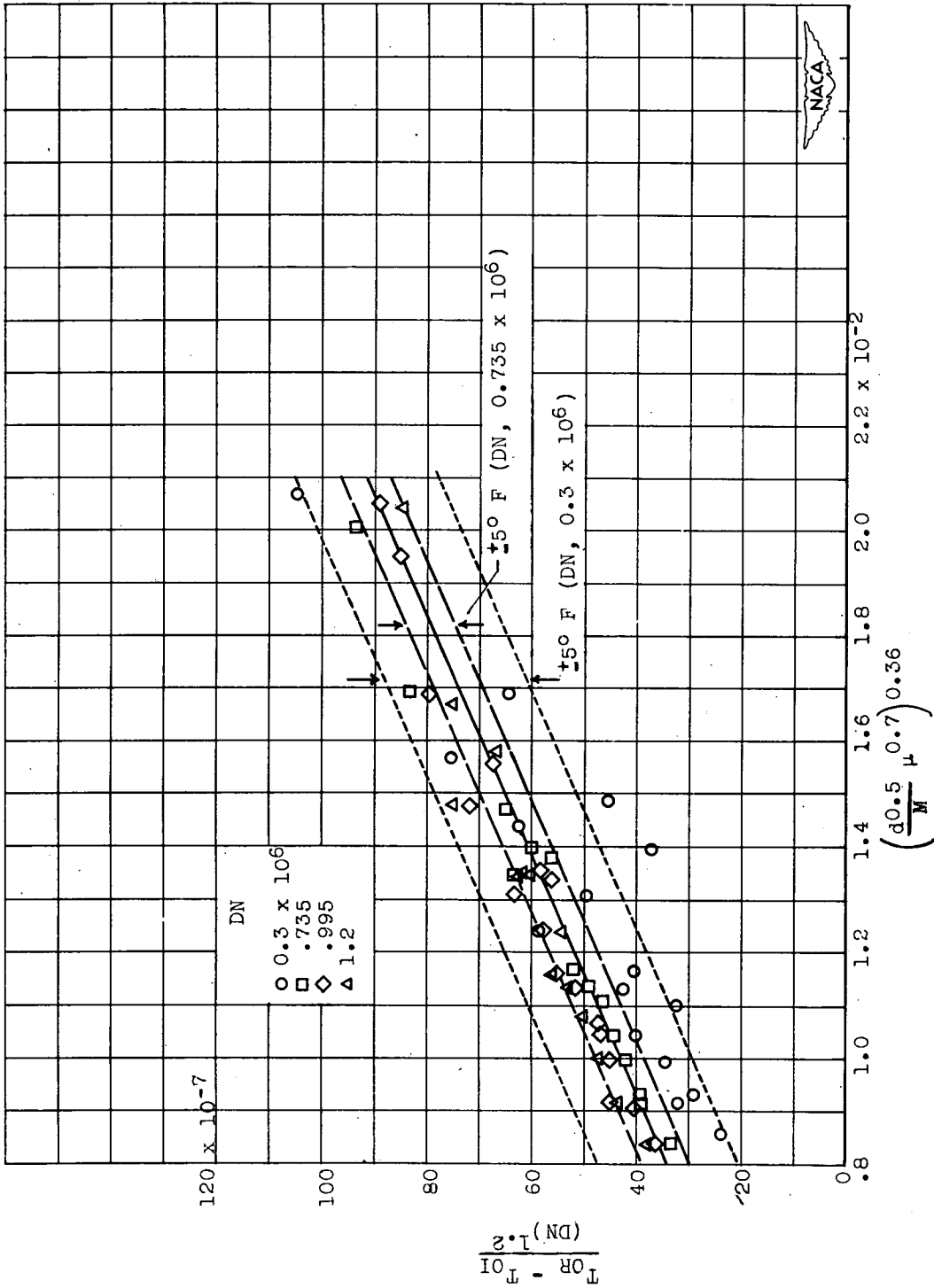
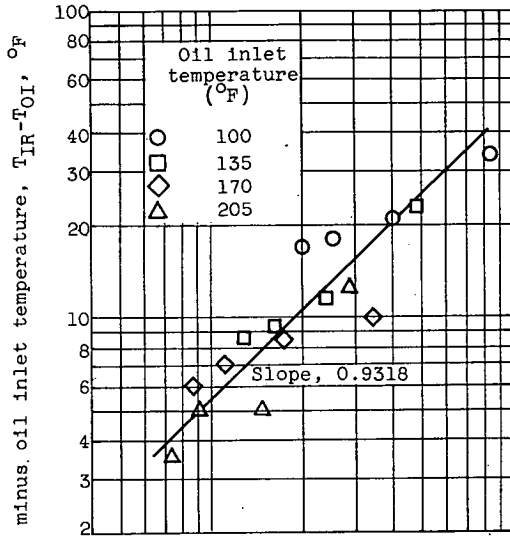
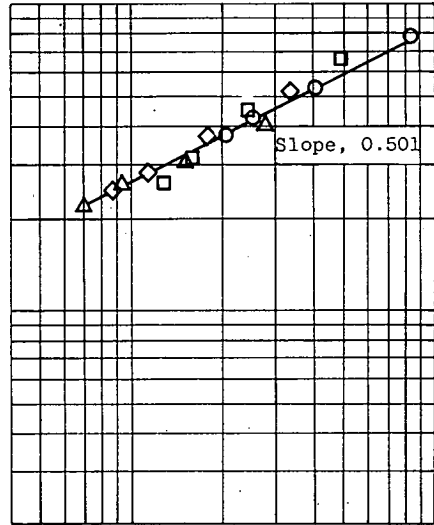

Figure 13. - Cooling-correlation curve for outer-race temperature of bearing 10. (Temperature, °F; DN, bearing bore in mm times shaft speed in rpm; viscosity, lb-sec/sq in.; oil-jet diameter, in.; oil flow, lb/min.)



(a) DN,  $0.3 \times 10^6$ .



(b) DN,  $0.735 \times 10^6$ .

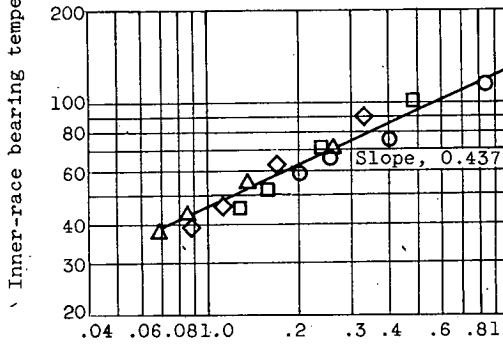

(c) DN,  $0.995 \times 10^6$ .

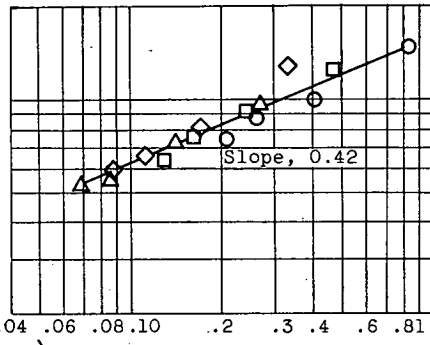

(d) DN,  $1.2 \times 10^6$ .

Figure 14. - Determination of exponent  $n$  for cooling correlation of inner-race temperatures of bearing 10 for various DN values.

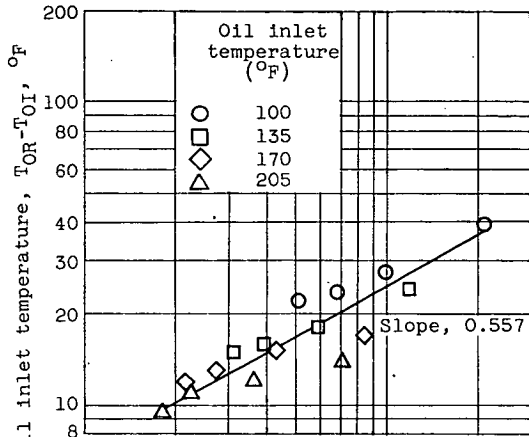

(a) DN,  $0.3 \times 10^6$ .

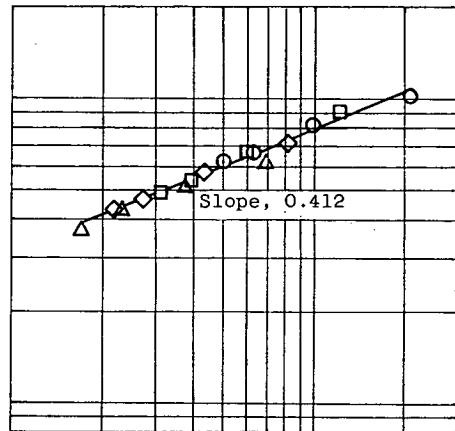

(b) DN,  $0.735 \times 10^6$ .

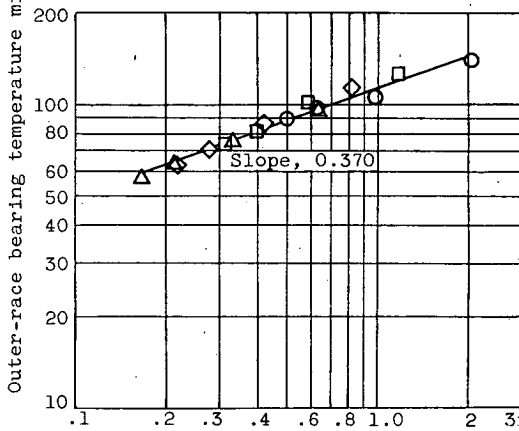

(c) DN,  $0.995 \times 10^6$ .

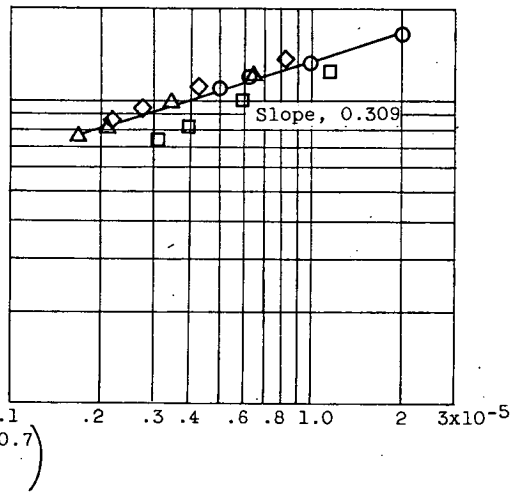

(d) DN,  $1.2 \times 10^6$ .

Figure 15. - Determination of exponent  $n$  for cooling correlation of outer-race temperatures of bearing 10 for various DN values.



**NACA TN 2420**  
National Advisory Committee for Aeronautics.  
**INVESTIGATION OF 75-MILLIMETER-BORE  
CYLINDRICAL-ROLLER BEARINGS AT HIGH  
SPEEDS. III - LUBRICATION AND COOLING  
STUDIES - OIL INLET DISTRIBUTION, OIL INLET  
TEMPERATURE, AND GENERALIZED SINGLE-OIL-  
JET COOLING-CORRELATION ANALYSIS.** E. Fred  
Macks and Zolton N. Nemeth. July 1951. 49p.  
diags., 2 tabs. (NACA TN 2420)

Oil inlet distribution (5 methods were investigated) and oil inlet temperature (100° to 205° F) were found to be significant factors in the cooling effectiveness of a given quantity of oil. Dimensional analysis was used to generalize the test-rig results so that it is possible to predict the inner- or outer-race temperatures above oil inlet temperature from a single curve regardless of whether speed, load, oil flow, oil inlet temperature, oil-jet diameter or any combination of the parameters is varied.

Copies obtainable from NACA, Washington

1. Friction and Lubrication  
- Theory and Experiment (3.8.1)
  2. Friction and Lubrication  
- Hydrodynamic Theory (3.8.1.1)
  3. Surfaces, Contact -  
Rolling (3.8.3)
  4. Bearings, Anti-Friction  
(3.8.3.1)
  5. Surfaces, Contact -  
Sliding and Rolling (3.8.4)
- I. Macks, Elmer Fred  
II. Nemeth, Zolton N.  
III. NACA TN 2420



**NACA TN 2420**  
National Advisory Committee for Aeronautics.  
**INVESTIGATION OF 75-MILLIMETER-BORE  
CYLINDRICAL-ROLLER BEARINGS AT HIGH  
SPEEDS. III - LUBRICATION AND COOLING  
STUDIES - OIL INLET DISTRIBUTION, OIL INLET  
TEMPERATURE, AND GENERALIZED SINGLE-OIL-  
JET COOLING-CORRELATION ANALYSIS.** E. Fred  
Macks and Zolton N. Nemeth. July 1951. 49p.  
diags., 2 tabs. (NACA TN 2420)

Oil inlet distribution (5 methods were investigated) and oil inlet temperature (100° to 205° F) were found to be significant factors in the cooling effectiveness of a given quantity of oil. Dimensional analysis was used to generalize the test-rig results so that it is possible to predict the inner- or outer-race temperatures above oil inlet temperature from a single curve regardless of whether speed, load, oil flow, oil inlet temperature, oil-jet diameter or any combination of the parameters is varied.

Copies obtainable from NACA, Washington

1. Friction and Lubrication  
- Theory and Experiment (3.8.1)
  2. Friction and Lubrication  
- Hydrodynamic Theory (3.8.1.1)
  3. Surfaces, Contact -  
Rolling (3.8.3)
  4. Bearings, Anti-Friction  
(3.8.3.1)
  5. Surfaces, Contact -  
Sliding and Rolling (3.8.4)
- I. Macks, Elmer Fred  
II. Nemeth, Zolton N.  
III. NACA TN 2420



**NACA TN 2420**  
National Advisory Committee for Aeronautics.  
**INVESTIGATION OF 75-MILLIMETER-BORE  
CYLINDRICAL-ROLLER BEARINGS AT HIGH  
SPEEDS. III - LUBRICATION AND COOLING  
STUDIES - OIL INLET DISTRIBUTION, OIL INLET  
TEMPERATURE, AND GENERALIZED SINGLE-OIL-  
JET COOLING-CORRELATION ANALYSIS.** E. Fred  
Macks and Zolton N. Nemeth. July 1951. 49p.  
diags., 2 tabs. (NACA TN 2420)

Oil inlet distribution (5 methods were investigated) and oil inlet temperature (100° to 205° F) were found to be significant factors in the cooling effectiveness of a given quantity of oil. Dimensional analysis was used to generalize the test-rig results so that it is possible to predict the inner- or outer-race temperatures above oil inlet temperature from a single curve regardless of whether speed, load, oil flow, oil inlet temperature, oil-jet diameter or any combination of the parameters is varied.

Copies obtainable from NACA, Washington

1. Friction and Lubrication  
- Theory and Experiment (3.8.1)
  2. Friction and Lubrication  
- Hydrodynamic Theory (3.8.1.1)
  3. Surfaces, Contact -  
Rolling (3.8.3)
  4. Bearings, Anti-Friction  
(3.8.3.1)
  5. Surfaces, Contact -  
Sliding and Rolling (3.8.4)
- I. Macks, Elmer Fred  
II. Nemeth, Zolton N.  
III. NACA TN 2420



**NACA TN 2420**  
National Advisory Committee for Aeronautics.  
**INVESTIGATION OF 75-MILLIMETER-BORE  
CYLINDRICAL-ROLLER BEARINGS AT HIGH  
SPEEDS. III - LUBRICATION AND COOLING  
STUDIES - OIL INLET DISTRIBUTION, OIL INLET  
TEMPERATURE, AND GENERALIZED SINGLE-OIL-  
JET COOLING-CORRELATION ANALYSIS.** E. Fred  
Macks and Zolton N. Nemeth. July 1951. 49p.  
diags., 2 tabs. (NACA TN 2420)

Oil inlet distribution (5 methods were investigated) and oil inlet temperature (100° to 205° F) were found to be significant factors in the cooling effectiveness of a given quantity of oil. Dimensional analysis was used to generalize the test-rig results so that it is possible to predict the inner- or outer-race temperatures above oil inlet temperature from a single curve regardless of whether speed, load, oil flow, oil inlet temperature, oil-jet diameter or any combination of the parameters is varied.

Copies obtainable from NACA, Washington

1. Friction and Lubrication  
- Theory and Experiment (3.8.1)
  2. Friction and Lubrication  
- Hydrodynamic Theory (3.8.1.1)
  3. Surfaces, Contact -  
Rolling (3.8.3)
  4. Bearings, Anti-Friction  
(3.8.3.1)
  5. Surfaces, Contact -  
Sliding and Rolling (3.8.4)
- I. Macks, Elmer Fred  
II. Nemeth, Zolton N.  
III. NACA TN 2420

