

DIVISION COPY

NACA TN 2512

# NATIONAL ADVISORY COMMITTEE FOR AERONAUTICS

TECHNICAL NOTE 2512

STRESSES IN A TWO-BAY NONCIRCULAR CYLINDER

UNDER TRANSVERSE LOADS

By George E. Griffith

Langley Aeronautical Laboratory  
Langley Field, Va.



Washington

October 1951



3 1176 01433 9775

NATIONAL ADVISORY COMMITTEE FOR AERONAUTICS

TECHNICAL NOTE 2512

STRESSES IN A TWO-BAY NONCIRCULAR CYLINDER

UNDER TRANSVERSE LOADS

By George E. Griffith

SUMMARY

A method, taking into account the effects of flexibility and based on a general eighth-order differential equation, is presented for finding the stresses in a two-bay, noncircular cylinder the cross section of which can be composed of circular arcs. Numerical examples are given for two cases of ring flexibility for a cylinder of doubly symmetrical (essentially elliptic) cross section, subjected to concentrated radial, moment, and tangential loads. The results parallel those already obtained for shells with circular rings.

INTRODUCTION

In airplane fuselages with flexible rings subjected to concentrated loads, the stresses in the neighborhood of the load differ markedly from those given by the simple engineering formulas, and more refined methods, which take into account the interaction of rings and shell, are needed to predict the stresses accurately. The first paper on this subject, published in May 1944, was that of Wignot, Combs, and Ensrud (reference 1), who treated the circular cylinder subjected to concentrated loads but neglected the effect of the extensional deformations of the shell. Hoff (reference 2) gave a more complete analysis, including the effects of many rings, for the case of symmetric transverse loads. The results were corroborated experimentally by Kuhn, Duberg, and Griffith (reference 3), who also extended the theory to include concentrated moment and tangential loads. Later, Duberg and Kempner (references 4 and 5) reduced the labor of computation by giving the results in the form of charts and showed that for practical purposes it was usually sufficient to consider only a region within 2 bay lengths of the load. Further investigations considered additional effects, heretofore neglected, such as the shearing and axial deformation of the rings (references 6 to 8), bending rigidity of stringers (references 8 and 9), shear carried by the stringers (reference 7), and eccentricity of ring and sheet (references 6, 7, 8, and 10).

All investigations referred to dealt exclusively with reinforced monocoque cylinders of circular cross section. The present paper gives an analysis for a two-bay noncircular cylinder, enclosed between ring bulkheads rigid in their planes, with the middle, flexible ring subjected to concentrated and distributed loads. The fundamental assumptions used in the analysis are the same as those previously used for circular cylinders.

Many noncircular fuselages can be closely approximated by using circular sections of different radii and joining the sections at points of tangency. The rings discussed herein are of this form. Associated with each ring section is a two-bay panel (fig. 1), any number of similar panels comprising the complete two-bay cylinder. The solution for the stresses in such a structure is based on the development of a general eighth-order differential equation, written in terms of the moment at the skin center line. A separate differential equation of the same general form applies to each curved panel in the structure. Application of the correct boundary conditions results in sets of simultaneous equations which yield the unknown constants in the moment expression.

Although a two-bay cylinder does not conform to the usual fuselage structure, it is believed, on the basis of comparisons with some of the work previously mentioned, that the results obtained are indicative of those found in more complicated structures. In accordance with the findings of prior investigations, shear and axial deformations of the loaded ring are neglected, but eccentricity of ring and sheet is included.

The numerical examples deal with a doubly symmetrical, two-bay cylinder of nearly elliptic cross section (fig. 2), subjected to concentrated loads.

#### SYMBOLS

$$A = \frac{t'R^6}{IL^3}$$

$$B = \frac{Et'R^2}{GtL^2}$$

$C_q$  coefficient of shear flow in sheet

$C_H$  coefficient of ring axial force

$C_M$  coefficient of ring bending moment

$C_V$  coefficient of ring shear force

E	Young's modulus in sheet and ring, pounds per square inch
G	shear modulus in sheet, pounds per square inch
H	axial force acting on sheet, pounds
I	moment of inertia of ring section, inches <sup>4</sup>
L	length of bay, inches
M	bending moment at sheet center line, inch-pounds
M <sub>C</sub>	applied concentrated moment, inch-pounds
M <sub>R</sub>	bending moment about neutral axis of ring, inch-pounds
P	applied concentrated radial load, pounds
R	radius to sheet center line of circular panel, inches
R <sub>1</sub> , R <sub>2</sub>	radii of circular panels comprising cylinder, inches
T	applied concentrated tangential load, pounds
V	shear force, pounds
a ± bi	complex roots of auxiliary algebraic equation (used when real roots also occur)
c <sub>1</sub> ± d <sub>1</sub> i, c <sub>2</sub> ± d <sub>2</sub> i	complex roots of auxiliary algebraic equation (used when no real roots occur)
e	eccentricity of ring and sheet (distance between sheet center line and neutral axis of ring), inches
f	distributed radial load acting on sheet, pounds per inch
h	distributed axial load acting on sheet, pounds per inch
i = √-1	
k <sub>1</sub> , k <sub>2</sub>	real roots of auxiliary algebraic equation
m	distributed moment acting on sheet, inch-pounds per inch
p	normal force in stringers, pounds per inch

q	shear flow in sheet, pounds per inch
s	distance in circumferential direction, inches
t	thickness of all material carrying bending stresses in panel if uniformly spread around circumference, inches
t	thickness of sheet, inches
u	displacement of sheet in axial direction, inches
v	displacement of sheet in circumferential direction, inches
$v_0$	displacement of sheet in circumferential direction at ring, inches
w	displacement of sheet or ring in radial direction, inches
x	distance in axial direction measured from loaded ring, inches
$\gamma$	shear strain in sheet
$\epsilon_s$	normal strain in sheet in circumferential direction
$\epsilon_x$	normal strain in sheet in x-direction
$\theta$	angular distance, degrees or radians
$\sigma$	stringer normal stress, pounds per square inch
$\sigma_s$	normal stress in sheet in circumferential direction, pounds per square inch
$\tau$	shear stress in sheet, pounds per square inch

#### GENERAL DIFFERENTIAL EQUATION

The basic element of the present analysis is a two-bay panel, as shown in figure 1, composed of sheet, longitudinal stiffeners or stringers, and transverse stiffening ring sections of constant radius. Distributed or concentrated loads are applied in the plane of the middle or flexible ring. By joining several panels at points of tangency, many two-bay cylinders of various cross-sectional shapes can be achieved.

In actual practice the sheet covering is outside the rings, and this eccentricity of sheet and ring is henceforth taken into account.

For convenience the moment considered is the moment which exists at the sheet center line rather than at the neutral axis of the ring. From this moment the bending moment in the ring is easily found.

The underlying assumptions used in the analysis are as follows:

(1) The shear stress, carried by the sheet alone, may vary in the circumferential direction but remains constant in the axial direction.

(2) The material in the cross section of the panel (sheet and stringers) capable of carrying normal stresses due to bending of the panel is assumed spread around the circumference in a fictitious sheet of thickness  $t'$ .

(3) The loaded ring has no torsional stiffness or bending stiffness out of its plane.

(4) The end ring supports are restrained from deforming in their planes but are free to warp out of their planes.

Under these assumptions, for any panel with constant geometrical properties, a general differential equation is developed for the moment at the sheet center line. All forces, stresses, and displacements in the panel may be obtained from that moment. The general differential equation (see the appendix for development) is

$$\frac{d^8 M}{d\theta^8} + (2 - 3B) \frac{d^6 M}{d\theta^6} + \left(1 - 6B + \frac{6e^2 A}{R^2}\right) \frac{d^4 M}{d\theta^4} - 3 \left[ B - \frac{2eA}{R} \left(2 - \frac{e}{R} + \frac{e^2}{R^2}\right) \right] \frac{d^2 M}{d\theta^2} + 6A \left(1 - \frac{e}{R} + \frac{e^2}{R^2}\right) M = F(\theta) \quad (1)$$

where

$$F(\theta) = R^2 \left[ \frac{d^5 h}{d\theta^5} + (1 - 3B) \frac{d^3 h}{d\theta^3} - 3B \frac{dh}{d\theta} \right] + R^2 \left[ \frac{d^6 f}{d\theta^6} + (1 - 3B) \frac{d^4 f}{d\theta^4} - 3 \left( B - \frac{2e^2 A}{R^2} \right) \frac{d^2 f}{d\theta^2} + \frac{6eA}{R} \left( 1 - \frac{e}{R} + \frac{e^2}{R^2} \right) f \right] + R \left\{ \frac{d^7 m}{d\theta^7} + (2 - 3B) \frac{d^5 m}{d\theta^5} + \left( 1 - 6B + \frac{6e^2 A}{R^2} \right) \frac{d^3 m}{d\theta^3} - 3 \left[ B - \frac{2eA}{R} \left( 1 - \frac{e}{R} + \frac{e^2}{R^2} \right) \right] \frac{dm}{d\theta} \right\}$$

When the ratio  $e/R$ , a measure of the eccentricity of the ring and sheet, is very small ( $\frac{e}{R} \ll \sqrt{\frac{E}{A}}$ ) it can be neglected; equation (1) then contains only the two nondimensional parameters  $A$  and  $B$ , which are related to the geometry and physical properties of the panel:  $A = \frac{t'R^6}{IL^3}$  and  $B = \frac{Et'R^2}{GtL^2}$ . The ratio  $A/B$  is an index of the over-all flexibility of the structure. When this ratio is very small the ring section is rather rigid. A large value of  $A/B$  (500, for example) indicates that the ring section is somewhat flexible, causing radical departures of the stress distributions from the elementary values. In actual practice the parameter  $B$  varies over a small range (between about 10 and 80), whereas  $A$  is usually much larger and may be as great as  $2 \times 10^7$ , or even more; consequently, flexibility may be thought of in terms of parameter  $A$  alone. Values of  $A$  less than about 200 usually indicate relatively inflexible rings, and increasing values indicate increasing ring flexibility.

The right-hand side of equation (1),  $F(\theta)$ , contains terms resulting from the application of distributed loads; if only concentrated loads are present  $F(\theta)$  becomes zero.

#### SOLUTION OF GENERAL DIFFERENTIAL EQUATION

The solution of equation (1) depends upon the nature of the roots of the auxiliary algebraic equation associated with the differential equation. Of the required eight roots of the algebraic equation, four may be real and four complex, or all eight may be complex. (For the special case of no eccentricity of ring and sheet, sets of roots for several combinations of parameters  $A$  and  $B$  are given in table I.)

If there are four real roots  $\pm k_1$ ,  $\pm k_2$  and four complex roots  $\pm(a \pm bi)$ , the solution for the bending moment is

$$\begin{aligned}
 M = & C_I e^{k_1 \theta} + C_{II} e^{-k_1 \theta} + C_{III} e^{k_2 \theta} + C_{IV} e^{-k_2 \theta} + \\
 & C_V e^{(a+bi)\theta} + C_{VI} e^{(a-bi)\theta} + C_{VII} e^{-(a+bi)\theta} + \\
 & C_{VIII} e^{-(a-bi)\theta} + \text{Particular solution} \quad (2)
 \end{aligned}$$

which can be written in real form as

$$M = C_1 \sinh k_1 \theta + C_2 \cosh k_1 \theta + C_3 \sinh k_2 \theta + C_4 \cosh k_2 \theta + \\ C_5 \sinh a \theta \cos b \theta + C_6 \sinh a \theta \sin b \theta + C_7 \cosh a \theta \sin b \theta + \\ C_8 \cosh a \theta \cos b \theta + gJ(\theta) \quad (3)$$

If there are four pairs of complex roots  $\pm(c_1 \pm d_1 i)$  and  $\pm(c_2 \pm d_2 i)$ , the bending moment is

$$M = C_{Ie}^{(c_1+d_1 i)\theta} + C_{IIe}^{(c_1-d_1 i)\theta} + C_{IIIe}^{-(c_1+d_1 i)\theta} + C_{IVe}^{-(c_1-d_1 i)\theta} + \\ C_{Ve}^{(c_2+d_2 i)\theta} + C_{VIe}^{(c_2-d_2 i)\theta} + C_{VIIe}^{-(c_2+d_2 i)\theta} + \\ C_{VIIIe}^{-(c_2-d_2 i)\theta} + \text{Particular solution} \quad (4)$$

which, written in real form, becomes

$$M = C_1 \sinh c_1 \theta \cos d_1 \theta + C_2 \sinh c_1 \theta \sin d_1 \theta + C_3 \cosh c_1 \theta \sin d_1 \theta + \\ C_4 \cosh c_1 \theta \cos d_1 \theta + C_5 \sinh c_2 \theta \cos d_2 \theta + C_6 \sinh c_2 \theta \sin d_2 \theta + \\ C_7 \cosh c_2 \theta \sin d_2 \theta + C_8 \cosh c_2 \theta \cos d_2 \theta + jJ(\theta) \quad (5)$$

Since the particular solutions  $gJ(\theta)$  and  $jJ(\theta)$  depend upon the form of  $F(\theta)$ , no formal solutions are given here. Further remarks concerning the solution of equation (1) are confined to the solution in real form, either equation (3) or equation (5).

Equation (3) or equation (5) expresses the moment in any particular panel where  $A$ ,  $B$ , and  $R$  are constant; such a solution exists for each panel constituting the structure to be analyzed. For the case of a circular cylinder, solution (3) or (5) is the same as the energy solutions of references 2 and 3 for a similar two-bay structure.

#### RELATION BETWEEN THE MOMENT $M$ AND OTHER FORCES AND DISPLACEMENTS

All forces and displacements in the panel may be expressed in terms of the moment given by equation (3) or (5) and derivatives of this moment.



As previously noted, this moment is the moment at the sheet center line, and with the exception of the ring bending moment all other forces and displacements are those at the center line of the sheet. When no eccentricity is involved the sheet center line coincides with the neutral axis of the ring. Of major interest in a structure such as the one described herein are the forces, stresses (obtainable from the forces), and displacements listed in the following paragraphs, together with their mathematical expressions which are readily obtained in general form in the appendix. These expressions become considerably simplified in the absence of distributed loads. (For positive sign convention of the displacements and forces see figs. 1 and 3, respectively.)

The eight quantities listed in this paragraph are associated with the boundary conditions (discussed in the next section). These quantities - the forces and displacements at the flexible ring, the shear flow at the panel edge, and the axial displacement between the flexible and rigid rings at the panel edge - are:

(1) Bending moment,  $M$

(2) Shear force

$$V = \frac{1}{R} \frac{dM}{d\theta} - m$$

(3) Axial force

$$H = -\frac{1}{R} \frac{d^2M}{d\theta^2} + Rf + \frac{dm}{d\theta}$$

(4) Sheet shear flow

$$q = \frac{1}{2R^2} \left\{ \frac{dM}{d\theta} + \frac{d^3M}{d\theta^3} - R^2 \left[ h + \frac{df}{d\theta} + \frac{1}{R} \left( m + \frac{d^2m}{d\theta^2} \right) \right] \right\}$$

(5) Axial displacement

$$u = \frac{L^2}{4R^3Et'} \left\{ \frac{d^2M}{d\theta^2} + \frac{d^4M}{d\theta^4} - R^2 \left[ \frac{dh}{d\theta} + \frac{d^2f}{d\theta^2} + \frac{1}{R} \left( \frac{dm}{d\theta} + \frac{d^3m}{d\theta^3} \right) \right] \right\}$$

(6) Tangential displacement

$$v_0 = -\frac{L}{2R^2Gt} \left\{ \frac{dM}{d\theta} + \frac{d^3M}{d\theta^3} - R^2 \left[ h + \frac{df}{d\theta} + \frac{1}{R} \left( m + \frac{d^2m}{d\theta^2} \right) \right] \right\} +$$

$$\frac{L^3}{6R^4Et} \left\{ \frac{d^3M}{d\theta^3} + \frac{d^5M}{d\theta^5} - R^2 \left[ \frac{d^2h}{d\theta^2} + \frac{d^3f}{d\theta^3} + \frac{1}{R} \left( \frac{d^2m}{d\theta^2} + \frac{d^4m}{d\theta^4} \right) \right] \right\}$$

(7) Radial displacement

$$w = -\frac{L}{2R^2Gt} \left\{ \frac{d^2M}{d\theta^2} + \frac{d^4M}{d\theta^4} - R^2 \left[ \frac{dh}{d\theta} + \frac{d^2f}{d\theta^2} + \frac{1}{R} \left( \frac{dm}{d\theta} + \frac{d^3m}{d\theta^3} \right) \right] \right\} +$$

$$\frac{L^3}{6R^4Et} \left\{ \frac{d^4M}{d\theta^4} + \frac{d^6M}{d\theta^6} - R^2 \left[ \frac{d^3h}{d\theta^3} + \frac{d^4f}{d\theta^4} + \frac{1}{R} \left( \frac{d^3m}{d\theta^3} + \frac{d^5m}{d\theta^5} \right) \right] \right\} +$$

$$\frac{eR}{EI} \left( M + \frac{e}{R} \frac{d^2M}{d\theta^2} - eRf - e \frac{dm}{d\theta} \right)$$

(8) Rotational displacements

$$\frac{dw}{ds} + \frac{v_0}{R} = -\frac{L}{2R^3Gt} \left\{ \frac{dM}{d\theta} + 2 \frac{d^3M}{d\theta^3} + \frac{d^5M}{d\theta^5} - R^2 \left[ h + \frac{d^2h}{d\theta^2} + \frac{df}{d\theta} + \frac{d^3f}{d\theta^3} + \right. \right.$$

$$\left. \frac{1}{R} \left( m + 2 \frac{d^2m}{d\theta^2} + \frac{d^4m}{d\theta^4} \right) \right] \right\} + \frac{L^3}{6R^5Et} \left\{ \frac{d^3M}{d\theta^3} + 2 \frac{d^5M}{d\theta^5} + \frac{d^7M}{d\theta^7} - \right.$$

$$\left. R^2 \left[ \frac{d^2h}{d\theta^2} + \frac{d^4h}{d\theta^4} + \frac{d^3f}{d\theta^3} + \frac{d^5f}{d\theta^5} + \frac{1}{R} \left( \frac{d^2m}{d\theta^2} + 2 \frac{d^4m}{d\theta^4} + \frac{d^6m}{d\theta^6} \right) \right] \right\} +$$

$$\frac{e}{EI} \left( \frac{dM}{d\theta} + \frac{e}{R} \frac{d^3M}{d\theta^3} - eR \frac{df}{d\theta} - e \frac{d^2m}{d\theta^2} \right)$$

The shear and normal stresses in the two supporting panels follow. The shear stress  $\tau$  in the sheet is given by

$$\tau = \frac{1}{2R^2t} \left\{ \frac{dM}{d\theta} + \frac{d^3M}{d\theta^3} - R^2 \left[ h + \frac{df}{d\theta} + \frac{1}{R} \left( m + \frac{d^2m}{d\theta^2} \right) \right] \right\} \quad (6)$$

The stringer normal stress  $\sigma$  is

$$\sigma = \frac{L - x}{2R3t'} \left\{ \frac{d^2 M}{d\theta^2} + \frac{d^4 M}{d\theta^4} - R^2 \left[ \frac{dh}{d\theta} + \frac{d^2 f}{d\theta^2} + \frac{1}{R} \left( \frac{dm}{d\theta} + \frac{d^3 m}{d\theta^3} \right) \right] \right\} \quad (7)$$

The ring bending moment, that is, the bending moment about the neutral axis of the ring, is

$$M_R = M + \frac{e}{R} \frac{d^2 M}{d\theta^2} - eRf - e \frac{dm}{d\theta} \quad (8)$$

For no eccentricity the moment at the sheet center line becomes the ring bending moment.

#### BOUNDARY CONDITIONS

Inasmuch as a general differential equation of the form of equation (1) applies for each of the panels comprising a given structure, a like number of bending-moment solutions of the form of equation (3) or (5) results. For the determination of the unknown coefficients appearing in these solutions a sufficient number of boundary conditions must be found, one for each coefficient. Regardless of the number of panels, the boundary conditions involve only the eight expressions listed in the previous section, consisting of the forces and displacements which occur at the sheet center line.

Although, for a particular problem, the application of these expressions depends upon the structure to be analyzed and the loading, all the boundary conditions may be summarized in one general statement: No change in displacement or forces can occur across a boundary unless a concentrated force is applied at the boundary, in which case the change in forces must equal the applied force. Any concentrated load in the plane of the ring can be resolved into a radial or shearing force, a tangential or normal force, and a moment. Then when a concentrated load is applied, the boundary conditions require that the difference in shear forces of the adjacent panels be equivalent to the applied radial load, the difference in axial forces be equivalent to the applied tangential load, and the difference in moments equal the applied moment. In the absence of any concentrated loads, all the forces and displacements must be continuous; that is, all eight expressions in one panel must equal the corresponding expressions in the adjacent panel. If a concentrated load is applied within a panel, it is necessary in the analysis to consider the point of application of the load as a boundary and, hence, to consider the panel as two panels, one on either side of the load.

Although terms associated with distributed loads appear in the expressions for the boundary conditions, distributed loads affect the boundary conditions only indirectly inasmuch as they affect the displacements.

Further discussion of boundary conditions, as they apply to one of the numerical examples, is given in the following section.

#### NUMERICAL EXAMPLES

The numerical examples deal with two geometrically similar cylinders constructed of four panels forming a doubly symmetrical, essentially elliptic cross section (fig. 2), with the flexible ring subjected to concentrated radial, moment, and tangential loads at an intersection with the major axis. Cylinder 1 has a very stiff loaded ring and cylinder 2 a relatively flexible loaded ring. For each cylinder the sheet thickness is constant, there is no eccentricity of ring and sheet, and the radius  $R_1$  of the top and bottom panels is one-third the radius  $R_2$  of the middle panels. The moment of inertia of each ring is constant, but because of the change in radius, the rings change in relative stiffness from one section to another as indicated by the change in  $A/B$  given in table II. As seen in figure 4, the top panel, section 1, joins the middle panel, section 2, at  $\theta = 60^\circ$ , and the middle panel joins the bottom panel, section 3, at  $\theta = 120^\circ$ . (These dimensions were also used in constructing fig. 2.)

Comparisons of the calculated distributions of bending moment, shear force, and axial force in the ring and of shear flow in the sheet with the distributions given by the elementary theory are shown in figures 5 to 10. The necessary numerical values used in the calculations are given in tables II and III. For ease in reading figures 5 to 10, the abscissa, although it actually represents distance along the perimeter, is given in degrees measured from the vertical axis of symmetry (as shown in fig. 4). Thus, since the ring perimeter of section 2 (fig. 4) is three times that of section 1 or section 3, whereas the angular distance for all three sections is the same ( $60^\circ$ ), the distance in figures 5 to 10 along the abscissa from  $120^\circ$  to  $60^\circ$  (corresponding to section 2) represents three times the distance from  $180^\circ$  to  $120^\circ$  or from  $60^\circ$  to  $0^\circ$  (corresponding to sections 1 and 3).

For the numerical examples, the labor of computation necessary to calculate the bending moment and other desired quantities may be shortened somewhat through cognizance that antisymmetrical loading produces an antisymmetrical moment distribution about the vertical axis and symmetrical loading yields a symmetrical distribution. Hence, only half the cylinder at the ring need be considered (fig. 4). The procedure used in obtaining the numerical results is illustrated by taking as an example cylinder 2 subjected to a concentrated radial load at  $\theta = 180^\circ$ . The discussion to follow is confined to cylinder 2 so loaded.

## Differential Equations and Solutions

In the top panel, section 1 (fig. 4), the differential equation is

$$\frac{d^8 M}{d\theta^8} - \frac{14}{3} \frac{d^6 M}{d\theta^6} - \frac{37}{3} \frac{d^4 M}{d\theta^4} - \frac{20}{3} \frac{d^2 M}{d\theta^2} + \frac{900000}{729} M = 0$$

The resulting auxiliary algebraic equation yields the eight complex roots (see table II):

$$\pm(c_1 \pm d_1 i) = \pm(2.509792 \pm 0.621665i)$$

$$\pm(c_2 \pm d_2 i) = \pm(0.915513 \pm 2.101999i)$$

Since symmetrical loading is applied to the structure, the moment in this section is given by only the symmetric terms:

$$M_{\text{section 1}} = C_2 \sinh c_1 \theta \sin d_1 \theta + C_4 \cosh c_1 \theta \cos d_1 \theta + \\ C_6 \sinh c_2 \theta \sin d_2 \theta + C_8 \cosh c_2 \theta \cos d_2 \theta \quad (9)$$

In the middle panel, section 2, the differential equation is

$$\frac{d^8 M}{d\theta^8} - 58 \frac{d^6 M}{d\theta^6} - 119 \frac{d^4 M}{d\theta^4} - 60 \frac{d^2 M}{d\theta^2} + 900000M = 0$$

The auxiliary algebraic equation has the eight roots (see table II):

$$\pm k_1 = \pm 5.534415$$

$$\pm k_2 = \pm 7.395633$$

$$\pm(a \pm bi) = \pm(2.181206 \pm 4.291882i)$$

The moment in section 2 is then

$$M_{\text{section 2}} = C_9' \sinh k_1 \theta + C_{10}' \cosh k_1 \theta + C_{11}' \sinh k_2 \theta + \\ C_{12}' \cosh k_2 \theta + C_{13} \sinh a\theta \cos b\theta + \\ C_{14} \sinh a\theta \sin b\theta + C_{15} \cosh a\theta \sin b\theta + \\ C_{16} \cosh a\theta \cos b\theta$$

but since  $k_1\theta$  and  $k_2\theta$ , when  $\theta = 60^\circ$  and  $\theta = 120^\circ$ , are large enough so that their respective hyperbolic sines and cosines are of almost equal magnitude, it is better for computational purposes to rewrite the moment in section 2 as

$$\begin{aligned}
 M_{\text{section 2}} = & C_9 e^{k_1\theta} + C_{10} e^{-k_1\theta} + C_{11} e^{k_2\theta} + C_{12} e^{-k_2\theta} + \\
 & C_{13} \sinh a\theta \cos b\theta + C_{14} \sinh a\theta \sin b\theta + \\
 & C_{15} \cosh a\theta \sin b\theta + C_{16} \cosh a\theta \cos b\theta \quad (10)
 \end{aligned}$$

For the bottom panel, section 3, the differential equation is the same as for the top panel and the auxiliary algebraic equation has the same roots. Hence, the moment is given by

$$\begin{aligned}
 M_{\text{section 3}} = & C_{17}' \sinh c_1\theta \cos d_1\theta + C_{18}' \sinh c_1\theta \sin d_1\theta + \\
 & C_{19}' \cosh c_1\theta \sin d_1\theta + C_{20}' \cosh c_1\theta \cos d_1\theta + \\
 & C_{21} \sinh c_2\theta \cos d_2\theta + C_{22} \sinh c_2\theta \sin d_2\theta + \\
 & C_{23} \cosh c_2\theta \sin d_2\theta + C_{24} \cosh c_2\theta \cos d_2\theta
 \end{aligned}$$

However, for  $\theta = 120^\circ$  and  $\theta = 180^\circ$  the hyperbolic sines and cosines, respectively, of  $c_1\theta$  are almost identical, and it is advisable for computational purposes to rewrite the moment in the bottom panel in the form

$$\begin{aligned}
 M_{\text{section 3}} = & C_{17} e^{c_1\theta} \cos d_1\theta + C_{18} e^{-c_1\theta} \cos d_1\theta + \\
 & C_{19} e^{c_1\theta} \sin d_1\theta + C_{20} e^{-c_1\theta} \sin d_1\theta + \\
 & C_{21} \sinh c_2\theta \cos d_2\theta + C_{22} \sinh c_2\theta \sin d_2\theta + \\
 & C_{23} \cosh c_2\theta \sin d_2\theta + C_{24} \cosh c_2\theta \cos d_2\theta \quad (11)
 \end{aligned}$$

#### Boundary Conditions

Equations (9) to (11) contain twenty unknown constants; hence, twenty boundary conditions are needed. No boundary conditions are found

at  $\theta = 0$ , since continuity of all forces and displacements is already satisfied as a consequence of taking advantage of the symmetry of the structure and loading. The boundary conditions to be used in the calculations must be found at  $\theta = 60^\circ$ ,  $\theta = 120^\circ$ , and  $\theta = 180^\circ$ .

Eight of the boundary conditions are supplied at  $\theta = 60^\circ$ , where, in the absence of any concentrated loads, all eight expressions in section 1 must equal the corresponding expressions in section 2. That is, the moment, shear force, displacements, and so forth, must be continuous. For example, the first condition requires continuity of the moments, or

$$M_{\text{section 1}} - M_{\text{section 2}} = 0$$

which can be written

$$\begin{aligned} & C_2 \sinh \frac{c_1 \pi}{3} \sin \frac{d_1 \pi}{3} + C_4 \cosh \frac{c_1 \pi}{3} \cos \frac{d_1 \pi}{3} + \\ & C_6 \sinh \frac{c_2 \pi}{3} \sin \frac{d_2 \pi}{3} + C_8 \cosh \frac{c_2 \pi}{3} \cos \frac{d_2 \pi}{3} - \\ & \left( C_9 e^{\frac{k_1 \pi}{3}} + C_{10} e^{-\frac{k_1 \pi}{3}} + C_{11} e^{\frac{k_2 \pi}{3}} + C_{12} e^{-\frac{k_2 \pi}{3}} + \right. \\ & C_{13} \sinh \frac{a \pi}{3} \cos \frac{b \pi}{3} + C_{14} \sinh \frac{a \pi}{3} \sin \frac{b \pi}{3} + \\ & \left. C_{15} \cosh \frac{a \pi}{3} \sin \frac{b \pi}{3} + C_{16} \cosh \frac{a \pi}{3} \cos \frac{b \pi}{3} \right) = 0 \end{aligned}$$

The other seven boundary conditions appearing at  $\theta = 60^\circ$  are written in a similar manner. The same continuity of the forces and displacements must exist at  $\theta = 120^\circ$ . Thus sixteen boundary conditions are provided, with the four remaining conditions to be found at  $\theta = 180^\circ$ .

For an applied radial load, the sum of the shearing forces on either side of the cut must equal the applied shearing load  $P$ . Because of the symmetry of the structure and loading, half of this load is carried by section 3 and the other half of the load is carried by the panel to the left, which need not be considered. Furthermore, the shear flow in the sheet is 0 at  $\theta = 180^\circ$ , there can be no tangential or sidewise displacement at  $\theta = 180^\circ$ , and there are no angular displacements caused by a concentrated radial load at this point. Hence, the four boundary conditions needed may be summed up as follows:

$$V_{180^\circ} = 0.5P \quad (12a)$$

$$q_{180^\circ} = 0 \quad (12b)$$

$$v_{0_{180^\circ}} = 0 \quad (12c)$$

$$\left( \frac{dw}{ds} + \frac{v_0}{R} \right)_{180^\circ} = 0 \quad (12d)$$

Equations (12a) to (12d) can be reduced by proper substitution to

$$(a) \left( \frac{dM}{d\theta} \right)_{180^\circ} = 0.5PR_1$$

$$(b) \left( \frac{d^3M}{d\theta^3} \right)_{180^\circ} = -0.5PR_1$$

$$(c) \left( \frac{d^5M}{d\theta^5} \right)_{180^\circ} = 0.5PR_1$$

$$(d) \left( \frac{d^7M}{d\theta^7} \right)_{180^\circ} = -0.5PR_1$$

For example, equation (12a) can be written

$$\begin{aligned} & C_{17} e^{c_1 \pi} (c_1 \cos d_1 \pi - d_1 \sin d_1 \pi) - C_{18} e^{-c_1 \pi} (c_1 \cos d_1 \pi + d_1 \sin d_1 \pi) + \\ & C_{19} e^{c_1 \pi} (c_1 \sin d_1 \pi + d_1 \cos d_1 \pi) - C_{20} e^{-c_1 \pi} (c_1 \sin d_1 \pi - d_1 \cos d_1 \pi) + \\ & C_{21} (c_2 \cosh c_2 \pi \cos d_2 \pi - d_2 \sinh c_2 \pi \sin d_2 \pi) + \\ & C_{22} (c_2 \cosh c_2 \pi \sin d_2 \pi + d_2 \sinh c_2 \pi \cos d_2 \pi) + \\ & C_{23} (c_2 \sinh c_2 \pi \sin d_2 \pi + d_2 \cosh c_2 \pi \cos d_2 \pi) + \\ & C_{24} (\sinh c_2 \pi \cos d_2 \pi - d_2 \cosh c_2 \pi \sin d_2 \pi) = 0.5PR_1 \end{aligned}$$



The solution of the twenty equations given by the boundary conditions yields the values of the unknown coefficients  $C_2, C_4, \dots, C_{23}, C_{24}$  shown in table III. The bending moment in the loaded ring at any angle  $\theta$  is then found by using equation (9), (10), or (11) with the appropriate coefficients. For example, substituting coefficients  $C_{17}$  to  $C_{24}$  from table III into equation (11) for  $\theta = 180^\circ$  gives

$$\begin{aligned}
 M_{180^\circ} &= -0.119054 \times 10^{-5} PR_1 (2.656444 \times 10^3) (-0.372983) + \\
 &\quad (-0.202194 \times 10^{-1} PR_1) (0.376443 \times 10^{-3}) (-0.372983) + \\
 &\quad (0.342801 \times 10^{-4} PR_1) (2.656444 \times 10^3) (0.927839) + \\
 &\quad (0.216297 \times 10^{-1} PR_1) (0.376443 \times 10^{-3}) (0.927839) + \\
 &\quad (-0.497509 \times 10^{-1} PR_1) (8.444906) (0.949098) + \\
 &\quad (-0.226239 \times 10^{-1} PR_1) (8.444906) (0.314983) + \\
 &\quad (0.375148 \times 10^{-1} PR_1) (8.901257) (0.314983) + \\
 &\quad (0.532861 \times 10^{-1} PR_1) (8.901257) (0.949098) \\
 &= 0.161390 PR_1
 \end{aligned}$$

#### CONCLUDING REMARKS

The results obtained from the numerical examples agree with those previously obtained for circular cylinders (see, for example, references 2 and 3) in indicating that concentrated loads applied to flexible rings produce stresses in the rings and shell considerably different from those computed from an engineering analysis (wherein the ring is treated as a free ring supported by the usual elementary torsion and bending shears).

Ring flexibility is essentially indicated by the parameter  $A \left( = \frac{t'R^6}{\pi L^3} \right)$ ; where  $A$  is everywhere less than about 200 the engineering analysis is adequate, but if  $A$  exceeds 200 such an analysis is inadequate.

The main effects of flexibility are to change considerably the distribution of stress and the magnitudes of the maximum stresses. The change in maximum stresses is indicated in the following table, which gives the approximate ratios of the absolute values of the maximum stress coefficients for cylinder 2 ( $A \approx 206$  near the load but 150,000 some distance away) to the maximum stress coefficients obtained from an engineering analysis:

Load \ Type of stress	$C_M$	$C_q$	$C_V$	$C_H$
Radial	0.5	4.5	1.0	1.4
Moment	1.0	47.5	3.4	6.3
Tangential	.2	5.4	.2	1.0

For much larger values of  $A$ , that is, for greater flexibility, the ratios greater than unity would increase considerably, those less than unity would decrease somewhat, and the ratios of unity would remain unchanged.

Langley Aeronautical Laboratory  
 National Advisory Committee for Aeronautics  
 Langley Field, Va., August 1, 1951

## APPENDIX

## DEVELOPMENT OF GENERAL DIFFERENTIAL EQUATION

Consider the two-bay panel with uniform geometrical properties (fig. 1), loaded in the plane of the middle ring. In accordance with the assumption that the shear stress in the sheet may vary circumferentially but remains constant in the axial direction, an infinitesimal element of the sheet is subject to the stresses shown in figure 1.

Equilibrium in the x-direction requires that

$$\frac{\partial \tau}{\partial s} t \, ds \, dx + \frac{\partial \sigma}{\partial x} t' \, dx \, ds = 0 \quad (A1)$$

Since

$$\tau t = q$$

and

$$\sigma t' = p$$

equation (A1) becomes

$$\frac{\partial p}{\partial x} + \frac{\partial q}{\partial s} = 0 \quad (A2)$$

Integrating equation (A2) with respect to x gives

$$p = -x \frac{\partial q}{\partial s} + f_1(s)$$

However, since the end ring supports are free to warp out of their planes,  $p = 0$  at  $x = L$ , and therefore

$$f_1(s) = L \frac{\partial q}{\partial s}$$

Then

$$p = (L - x) \frac{\partial q}{\partial s}$$

The strain relation in the x-direction gives

$$\frac{\partial u}{\partial x} = \epsilon_x = \frac{p}{Et'}$$

so that

$$\frac{\partial u}{\partial x} = \frac{1}{Et'} (L - x) \frac{\partial q}{\partial s} \quad (A3)$$

Integrating equation (A3) with respect to  $x$  gives

$$u = \frac{1}{Et'} \left( Lx - \frac{x^2}{2} \right) \frac{\partial q}{\partial s} + f_2(s)$$

but since, from symmetry of the structure and loading,  $u = 0$  at  $x = 0$ ,

$$f_2(s) = 0$$

so that

$$u = \frac{1}{Et'} \left( Lx - \frac{x^2}{2} \right) \frac{\partial q}{\partial s} \quad (A4)$$

The shear strain can be expressed as

$$\gamma = \frac{q}{Gt} = \frac{\partial u}{\partial s} + \frac{\partial v}{\partial x} \quad (A5)$$

from which  $u$  can be eliminated and  $v$  can be found in terms of  $q$ . Differentiating equation (A4) with respect to  $s$  and substituting the result into equation (A5) gives

$$\frac{\partial v}{\partial x} = \frac{q}{Gt} - \frac{1}{Et'} \left( Lx - \frac{x^2}{2} \right) \frac{\partial^2 q}{\partial s^2}$$

Integrating with respect to  $x$  yields

$$v = \frac{q}{Gt} x - \frac{1}{Et'} \left( \frac{Lx^2}{2} - \frac{x^3}{6} \right) \frac{\partial^2 q}{\partial s^2} + f_3(s)$$

but since the end ring supports are rigid in their planes,  $v = 0$  at  $x = L$ , and

$$f_3(s) = -\frac{L}{Gt} q + \frac{L^3}{3Et'} \frac{\partial^2 q}{\partial s^2}$$

so that

$$v = \frac{x - L}{Gt} q - \frac{1}{6Et'} (3Lx^2 - x^3 - 2L^3) \frac{\partial^2 q}{\partial s^2}$$

This displacement in the sheet at the ring, where  $x = 0$ , becomes

$$v_0 = -\frac{L}{Gt} q + \frac{L^3}{3R^2 Et'} \frac{\partial^2 q}{\partial \theta^2} \quad (A6)$$

The relation between the strain in the sheet in the circumferential direction and the deflections at the ring is

$$\epsilon_s = \frac{1}{R} \left( \frac{dv_0}{d\theta} - w \right)$$

where by continuity  $w$  is the radial deflection of both ring and sheet. Since the strain  $\epsilon_s$  in the sheet is the strain at the outermost fibers of the ring,

$$\epsilon_s = \frac{\sigma_s}{E} = -\frac{eM_R}{EI}$$

Thus the radial deflection can be expressed as

$$w = \frac{eRM_R}{EI} + \frac{dv_0}{d\theta} \quad (A7)$$

Differentiating equation (A6) and substituting the result into equation (A7) yields

$$w = \frac{eRM_R}{EI} - \frac{L}{Gt} \frac{dq}{d\theta} + \frac{L^3}{3R^2 Et'} \frac{d^3 q}{d\theta^3} \quad (A8)$$

The relation between the ring bending moment and the radial deflection is given by (see, for example, reference 11)

$$M_R = -\frac{EI}{(R - e)^2} \left( \frac{d^2 w}{d\theta^2} + w \right) \quad (A9)$$

Performing the indicated differentiation of equation (A8) and substituting the result into equation (A9) eliminates  $w$  and gives

$$M_R = -\frac{EI}{(R - e)^2} \left[ \frac{eR}{EI} \left( \frac{d^2 M_R}{d\theta^2} + M_R \right) - \frac{L}{Gt} \left( \frac{d^3 q}{d\theta^3} + \frac{dq}{d\theta} \right) + \frac{L^3}{3R^2 Et'} \left( \frac{d^5 q}{d\theta^5} + \frac{d^3 q}{d\theta^3} \right) \right] \quad (A10)$$

It is now convenient to find the relation between the shear flow in the sheet and the moment at the sheet center line, as well as to express the moment at the ring center line in terms of the moment at the sheet center line. Figure 3 shows an infinitesimal segment of the loaded ring and the positive directions of the forces. For the first of the three equations of equilibrium, taking moments about the origin gives

$$-dM + R dH + R^2 h d\theta + Rm d\theta + 2R^2 q d\theta = 0$$

or

$$q = \frac{1}{2R^2} \left( \frac{dM}{d\theta} - R \frac{dH}{d\theta} - R^2 h - Rm \right) \quad (A11)$$

Summation of the tangential forces (neglecting terms of higher order) gives

$$V d\theta - Rh d\theta - 2Rq d\theta - dH = 0$$

or

$$V = \frac{dH}{d\theta} + Rh + 2Rq \quad (A12)$$

Summation of the forces in the radial direction gives

$$-H d\theta + Rf d\theta - dV = 0$$

or

$$H = - \frac{dV}{d\theta} + Rf \quad (A13)$$

Substituting the value of  $\frac{dH}{d\theta}$  from equation (A12) into equation (A11) yields the shear force at  $\theta$ :

$$V = \frac{1}{R} \frac{dM}{d\theta} - m \quad (A14)$$

Differentiating equation (A14) and substituting the result into equation (A13) gives the value of the normal force at the sheet center line at  $\theta$ :

$$H = - \frac{1}{R} \frac{d^2 M}{d\theta^2} + Rf + \frac{dm}{d\theta} \quad (A15)$$

Differentiating equation (A15) and substituting the result into equation (A11) gives the expression for the shear flow in the sheet at  $\theta$ :

$$q = \frac{1}{2R^2} \left\{ \frac{dM}{d\theta} + \frac{d^3M}{d\theta^3} - R^2 \left[ h + \frac{df}{d\theta} + \frac{1}{R} \left( m + \frac{d^2m}{d\theta^2} \right) \right] \right\} \quad (A16)$$

The bending moment about the ring center line can be seen to be composed of the moment  $M$  and the product of the axial force  $H$  and the eccentricity  $e$ , or

$$\begin{aligned} M_R &= M - eH \\ &= M + \frac{e}{R} \frac{d^2M}{d\theta^2} - eRf - e \frac{dm}{d\theta} \end{aligned} \quad (A17)$$

Differentiation of equations (A16) and (A17) and substitution of the result into equation (A10) leads to the desired differential equation:

$$\begin{aligned} \frac{d^8M}{d\theta^8} + (2 - 3B) \frac{d^6M}{d\theta^6} + \left( 1 - 6B + \frac{6e^2A}{R^2} \right) \frac{d^4M}{d\theta^4} - \\ 3 \left[ B - \frac{2eA}{R} \left( 2 - \frac{e}{R} + \frac{e^2}{R^2} \right) \right] \frac{d^2M}{d\theta^2} + 6A \left( 1 - \frac{e}{R} + \frac{e^2}{R^2} \right) M = F(\theta) \end{aligned} \quad (A18)$$

where

$$\begin{aligned} F(\theta) = R^2 \left[ \frac{d^5h}{d\theta^5} + (1 - 3B) \frac{d^3h}{d\theta^3} - 3B \frac{dh}{d\theta} \right] + \\ R^2 \left[ \frac{d^6f}{d\theta^6} + (1 - 3B) \frac{d^4f}{d\theta^4} - 3 \left( B - \frac{2e^2A}{R^2} \right) \frac{d^2f}{d\theta^2} + \frac{6eA}{R} \left( 1 - \frac{e}{R} + \frac{e^2}{R^2} \right) f \right] + \\ R \left\{ \frac{d^7m}{d\theta^7} + (2 - 3B) \frac{d^5m}{d\theta^5} + \left( 1 - 6B + \frac{6e^2A}{R^2} \right) \frac{d^3m}{d\theta^3} - 3 \left[ B - \frac{2eA}{R} \left( 1 - \frac{e}{R} + \frac{e^2}{R^2} \right) \right] \frac{dm}{d\theta} \right\} \end{aligned}$$

Equation (A18) is the general form of the differential equation for the bending moment at the sheet center line for any of the panels comprising the structure. The bending moment in the ring for any such panel is given by equation (A17).

## REFERENCES

1. Wignot, J. E., Combs, Henry, and Ensrud, A. F.: Analysis of Circular Shell-Supported Frames. NACA TN 929, 1944.
2. Hoff, N. J.: Stresses in a Reinforced Monocoque Cylinder under Concentrated Symmetric Transverse Loads. Jour. Appl. Mech., vol. 11, no. 4, Dec. 1944, pp. A-235 - A-239.
3. Kuhn, Paul, Duberg, John E., and Griffith, George E.: The Effect of Concentrated Loads on Flexible Rings in Circular Shells. NACA ARR L5H23, 1945.
4. Duberg, John E., and Kempner, Joseph: Stress Analysis by Recurrence Formula of Reinforced Circular Cylinders under Lateral Loads. NACA TN 1219, 1947.
5. Kempner, Joseph, and Duberg, John E.: Charts for Stress Analysis of Reinforced Circular Cylinders under Lateral Loads. NACA TN 1310, 1947.
6. Beskin, Leon: Local Stress Distribution in Cylindrical Shells. Jour. Appl. Mech., vol. 13, no. 2, June 1946, pp. A-137 - A-147.
7. Hoff, N. J., Salerno, Vito L., and Boley, Bruno A.: Shear Stress Concentration and Moment Reduction Factors for Reinforced Monocoque Cylinders Subjected to Concentrated Radial Loads. Jour. Aero. Sci., vol. 16, no. 5, May 1949, pp. 277-288.
8. Airplane Structures Research Staff, Polytechnic Institute of Brooklyn: Concentrated Load Effects in Reinforced Monocoque Structures. Reissner Anniversary Volume: Contributions to Applied Mechanics. J. W. Edwards (Ann Arbor), 1949, pp. 277-332.
9. Levy, Robert S.: Effect of Bending Rigidity of Stringers upon Stress Distribution in Reinforced Monocoque Cylinder under Concentrated Transverse Loads. Jour. Appl. Mech., vol. 15, no. 1, March 1948, pp. 30-36.
10. Goodey, W. J.: The Stresses in a Circular Fuselage. Jour. R.A.S., vol. 50, no. 431, Nov. 1946, pp. 833-871.
11. Timoshenko, S.: Theory of Elastic Stability. McGraw-Hill Book Co., Inc., 1936, p.206.



TABLE I.-- ROOTS OF AUXILIARY ALGEBRAIC EQUATION WHEN  $e = 0$  FOR

SEVERAL COMBINATIONS OF A AND B

$$\left[ A = \frac{t'R^6}{IL^3} ; B = \frac{Et'R^2}{GtL^2} \right]$$

$\frac{B}{A}$	20	60	150	350	Root Symbols
$10^2$	$\pm 1.250205$ $\pm 7.745793$ $\pm(0.612234 \pm 1.467988i)$	$\pm 0.956180$ $\pm 13.416404$ $\pm(0.475554 \pm 1.297397i)$	$\pm 0.743842$ $\pm 21.213203$ $\pm(0.371310 \pm 1.189335i)$	$\pm 0.571042$ $\pm 32.403439$ $\pm(0.290865 \pm 1.113144i)$	$\pm k_1$ $\pm k_2$ $\pm(a \pm bi)$
$10^3$	$\pm 2.027436$ $\pm 7.744229$ $\pm(0.972538 \pm 1.996901i)$	$\pm 1.613689$ $\pm 13.416370$ $\pm(0.798821 \pm 1.714525i)$	$\pm 1.326187$ $\pm 21.213202$ $\pm(0.661073 \pm 1.521962i)$	$\pm 1.092601$ $\pm 32.403439$ $\pm(0.547534 \pm 1.374090i)$	$\pm k_1$ $\pm k_2$ $\pm(a \pm bi)$
$10^4$	$\pm 3.157270$ $\pm 7.728363$ $\pm(1.447531 \pm 2.818390i)$	$\pm 2.523294$ $\pm 13.416028$ $\pm(1.236394 \pm 2.388951i)$	$\pm 2.117014$ $\pm 21.213188$ $\pm(1.052130 \pm 2.085072i)$	$\pm 1.795392$ $\pm 32.403439$ $\pm(0.896469 \pm 1.845788i)$	$\pm k_1$ $\pm k_2$ $\pm(a \pm bi)$
$10^5$	$\pm 5.016203$ $\pm 7.539604$ $\pm(2.058771 \pm 4.030199i)$	$\pm 3.835266$ $\pm 13.412609$ $\pm(1.837706 \pm 3.417722i)$	$\pm 3.230542$ $\pm 21.213049$ $\pm(1.595017 \pm 2.959562i)$	$\pm 2.769566$ $\pm 32.403431$ $\pm(1.379274 \pm 2.593999i)$	$\pm k_1$ $\pm k_2$ $\pm(a \pm bi)$



TABLE II.- NUMERICAL VALUES USED IN COMPUTATIONS

$$\left[ A = \frac{t'R^6}{IL^3} ; B = \frac{Et'R^2}{GtL^2} \right]$$

Cylinder	Section	A	B	$\frac{A}{B}$	Roots of auxiliary equation
1	1 and 3	$\frac{50}{729}$	$\frac{20}{9}$	0.03	$\pm 0.236301$ $\pm 2.581786$ $\pm (0.109747 \pm 1.019532i)$
	2	50	20	2.50	$\pm 1.061451$ $\pm 7.745880$ $\pm (0.521510 \pm 1.354493i)$
2	1 and 3	$\frac{150000}{729}$	$\frac{20}{9}$	92.59	$\pm (2.509792 \pm 0.621665i)$ $\pm (0.915513 \pm 2.101999i)$
	2	150,000	20	7500.00	$\pm 5.534415$ $\pm 7.395633$ $\pm (2.181206 \pm 4.291882i)$

TABLE III.- VALUES OF COEFFICIENTS<sup>1</sup> FOR NUMERICAL EXAMPLES

Coefficient	Cylinder 1			Cylinder 2		
	Load			Load		
	Radial	Moment	Tangential	Radial	Moment	Tangential
C <sub>1</sub>	-----	0.147507	0.249767	-----	-0.860733-03	0.119301-03
C <sub>2</sub>	0.679031-01	-----	-----	0.949137-04	-----	-----
C <sub>3</sub>	-----	.275041-04	-.157406-03	-----	.292731-03	-.371518-04
C <sub>4</sub>	.125895-05	-----	-----	-.284700-03	-----	-----
C <sub>5</sub>	-----	-.136156	.754809	-----	-.148018-01	.221238-02
C <sub>6</sub>	-.525229	-----	-----	-.197121-02	-----	-----
C <sub>7</sub>	-----	-.165618	.236338-03	-----	-.521539-02	.484959-03
C <sub>8</sub>	.282018-01	-----	-----	-.354900-02	-----	-----
C <sub>9</sub>	.171565-01	.188166	.202467	-.657213-08	.140829-06	-.161423-07
C <sub>10</sub>	.303490-01	-.121785	-.111398	-.534558-01	.270768	-.697692-01
C <sub>11</sub>	-.264559-10	.116591-10	-.116591-10	.397640-09	-.161540-08	.710774-09
C <sub>12</sub>	.889303	-.508263-01	.851830	-.479259	-.380612+01	.638771
C <sub>13</sub>	.329176-01	-.296012	.472934	-.122989-01	-.361474-01	.485865-02
C <sub>14</sub>	-.490646	.373871-01	.290987	.829422-03	-.491296-01	.702908-02
C <sub>15</sub>	.192013	-.184225	-.160403	-.117551-02	.471184-01	-.668234-02
C <sub>16</sub>	.720834-01	.274929	-.400188-01	.131739-01	.392728-01	-.527300-02
C <sub>17</sub>	-.119460	-.164389-01	.174960	-.119054-05	.778086-04	-.192398-04
C <sub>18</sub>	.315057	.363960	.224540	-.202194+01	-.711069+01	.872951
C <sub>19</sub>	-.898224-08	.174922-09	.301271-07	.342801-04	.804877-04	.168139-04
C <sub>20</sub>	-.711275-02	-.259599	-.364881	.216297+01	.882602+01	-.112279+01
C <sub>21</sub>	-.640348-01	.207820-02	.128917+01	-.497509-01	-.142194	.194136-01
C <sub>22</sub>	-.531867	.131177-01	.506058-01	-.226239-01	-.709217-01	.370731-02
C <sub>23</sub>	-.254629	-.304436	-.328941	.375148-01	.124468	-.104012-01
C <sub>24</sub>	.194401-01	-.242335-01	-.613555-03	.532861-01	.167720	-.241624-01

<sup>1</sup>The following convention is used to indicate multiplication factors:

+01 =  $\times 10$ ; +02 =  $\times 10^2$ ; -01 =  $\times 10^{-1}$ ; -02 =  $\times 10^{-2}$ ; and so forth.



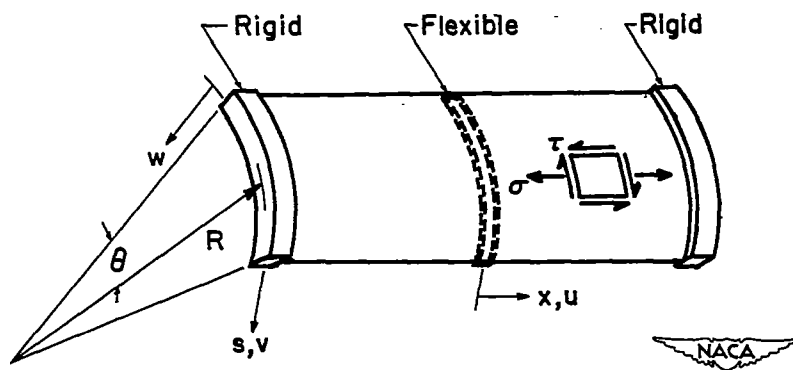

Figure 1.- Two-bay panel showing positive directions of displacements and sheet stresses.

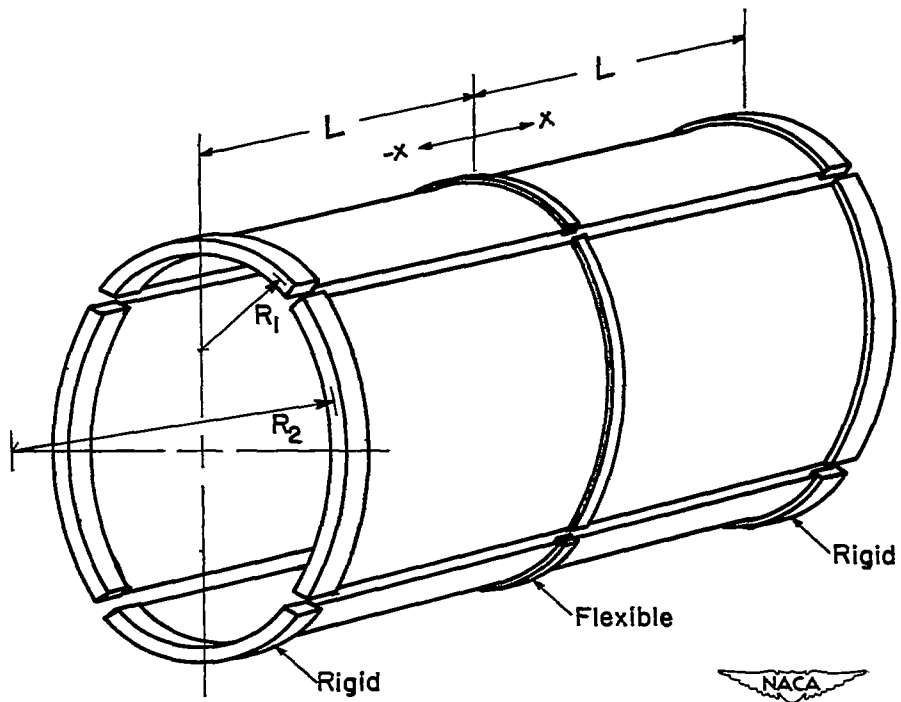

Figure 2.- Two-bay cylinder, composed of four circular panels, with doubly symmetrical noncircular rings, used for numerical examples.

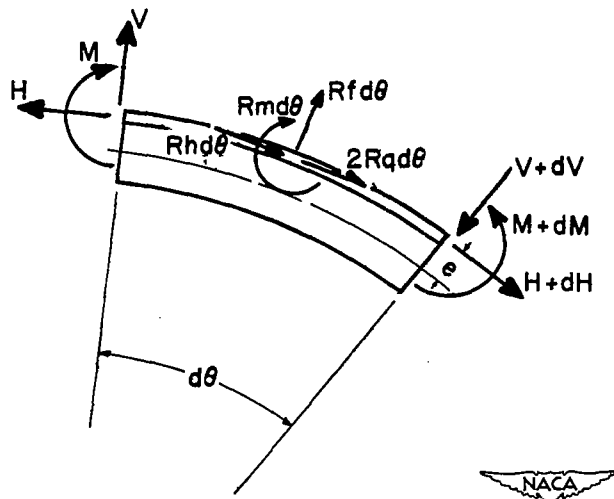

Figure 3.- Free-body diagram of ring section showing positive directions of forces.

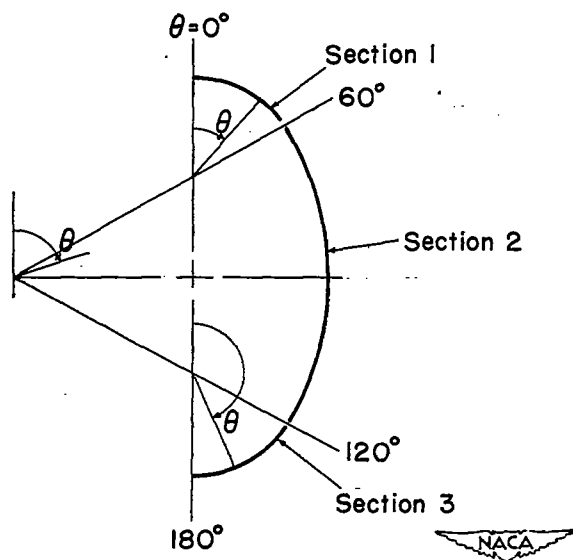
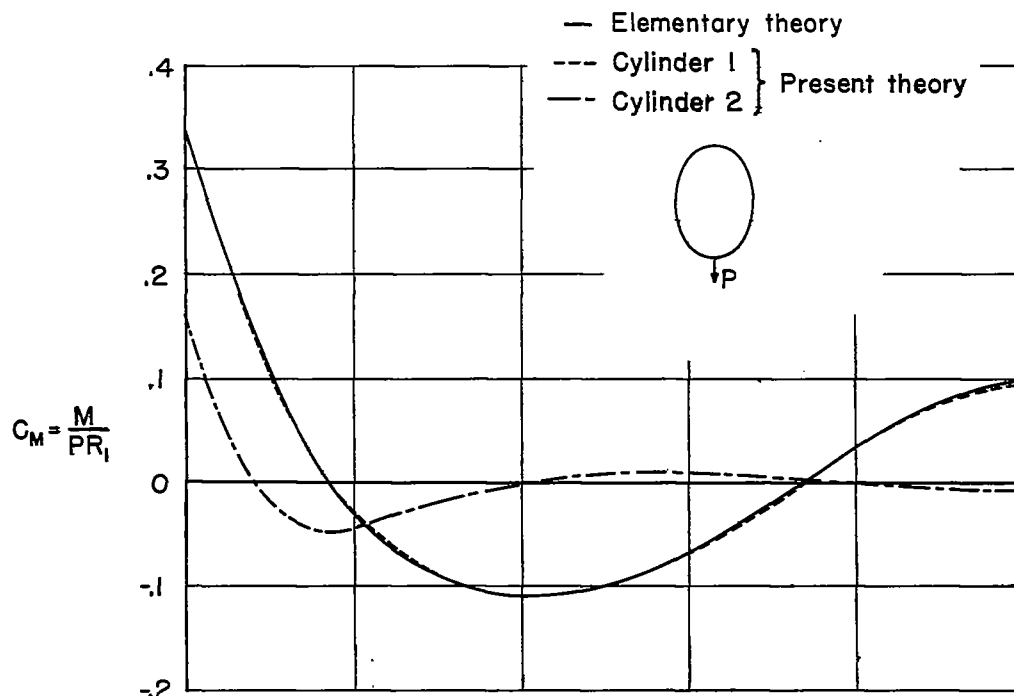
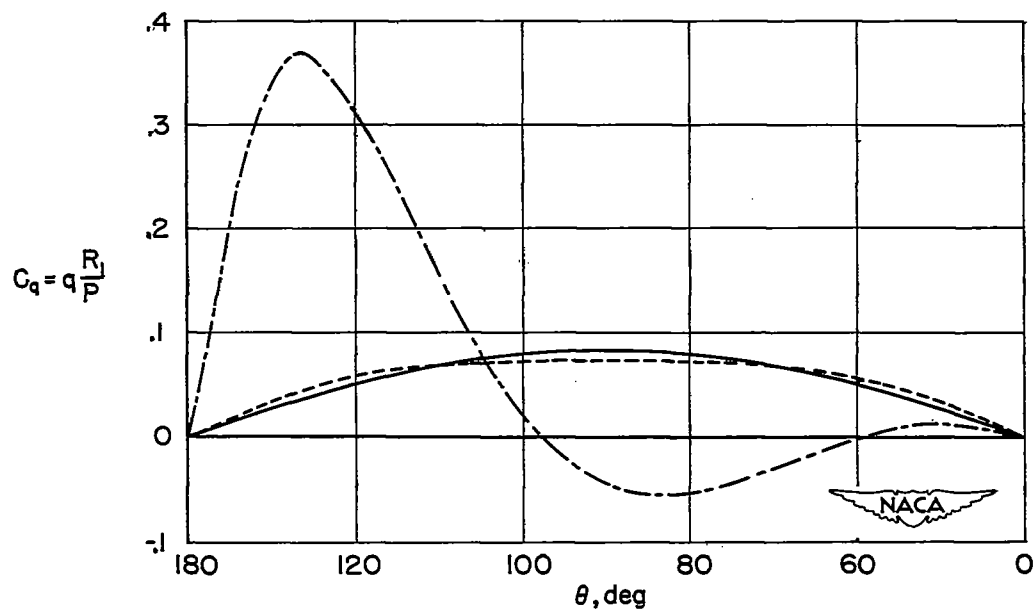

Figure 4.- Cross-sectional view of half of loaded ring used for numerical examples.



(a) Ring bending moment.



(b) Sheet shear flow.

Figure 3.-Bending-moment and shear-flow distributions produced by concentrated radial load  $P$  at  $\theta = 180^\circ$ .

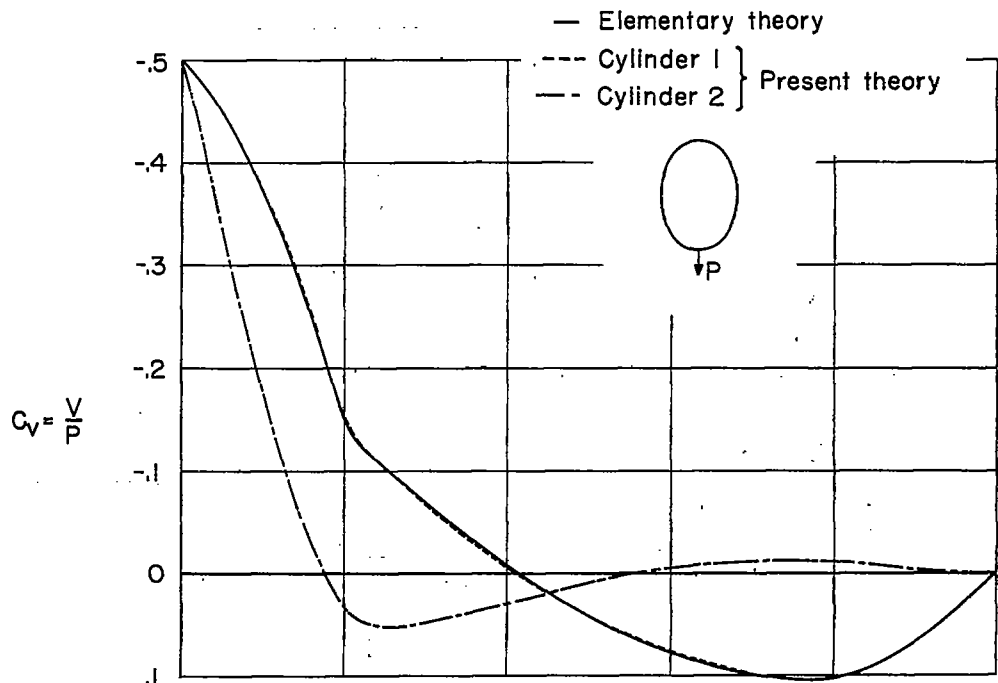

(a) Ring shear force.

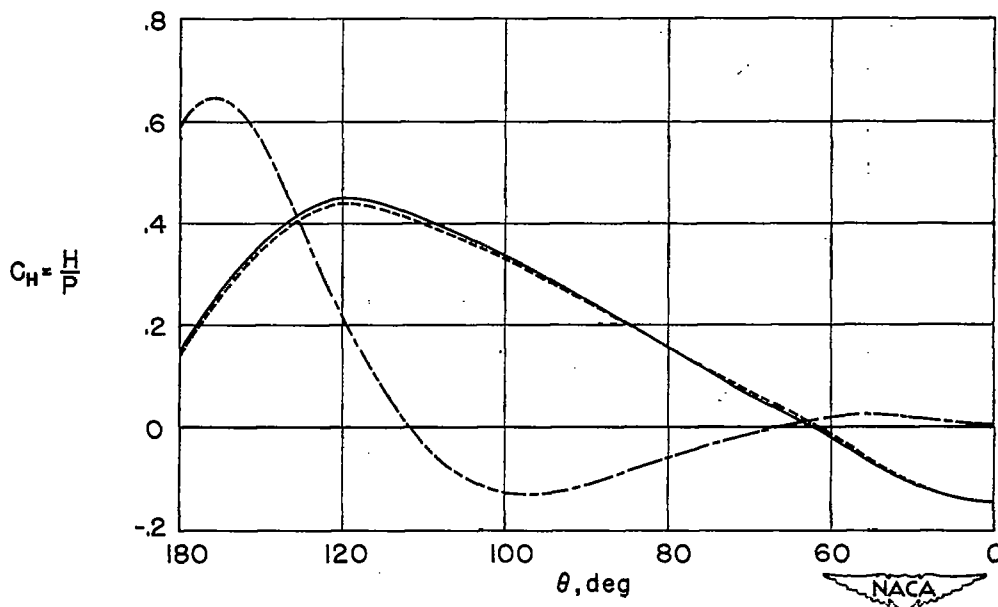

(b) Ring axial force.

Figure 6.- Ring shear- and axial-force distributions produced by concentrated radial load  $P$  at  $\theta = 180^\circ$ .

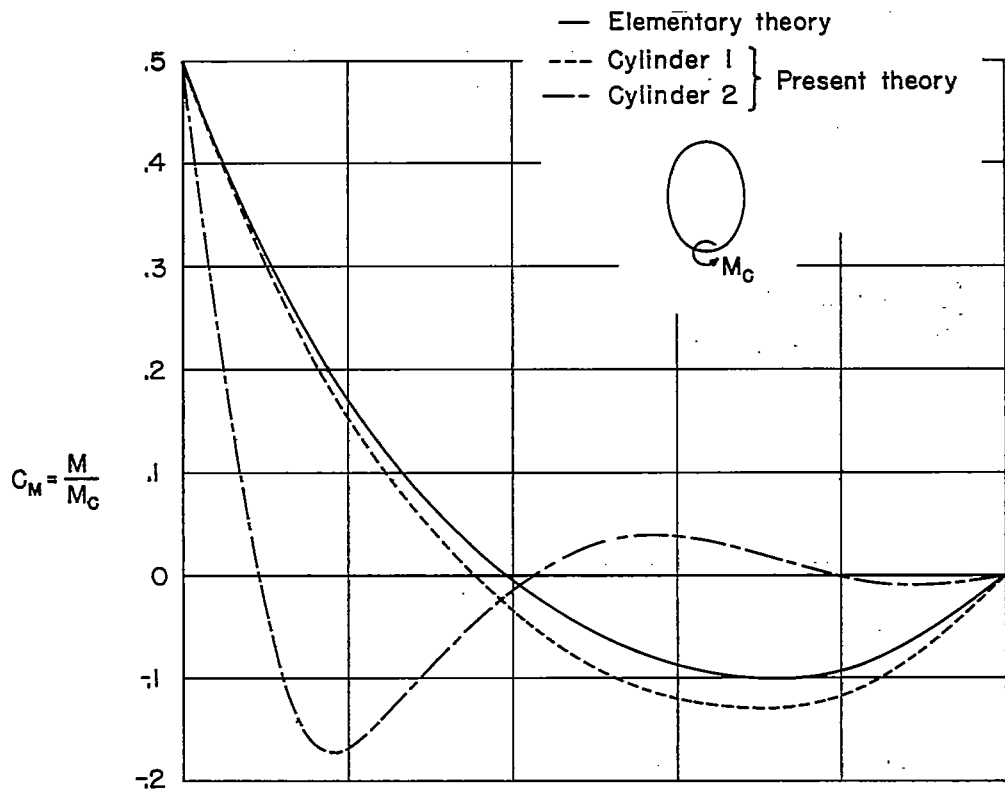

(a) Ring bending moment.

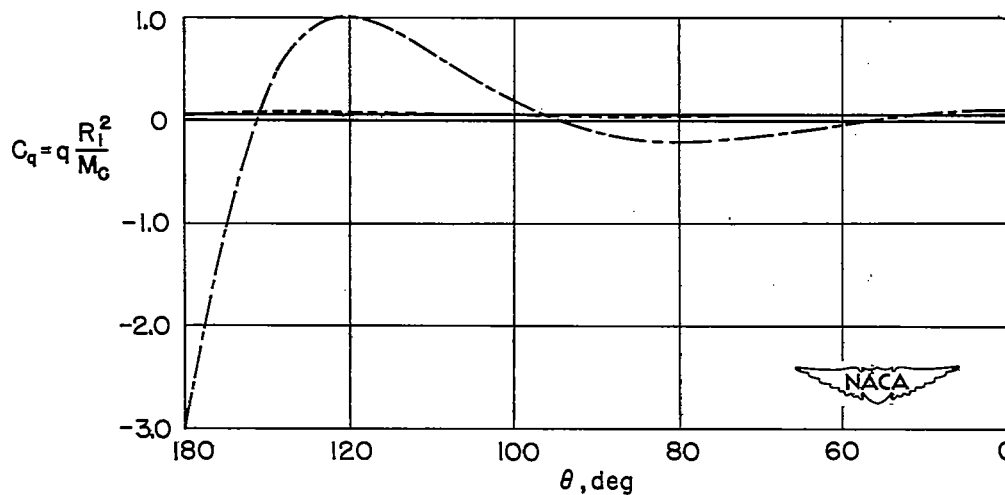

(b) Sheet shear flow.

Figure 7.- Bending-moment and shear-flow distributions produced by concentrated moment load  $M_C$  at  $\theta = 180^\circ$ .



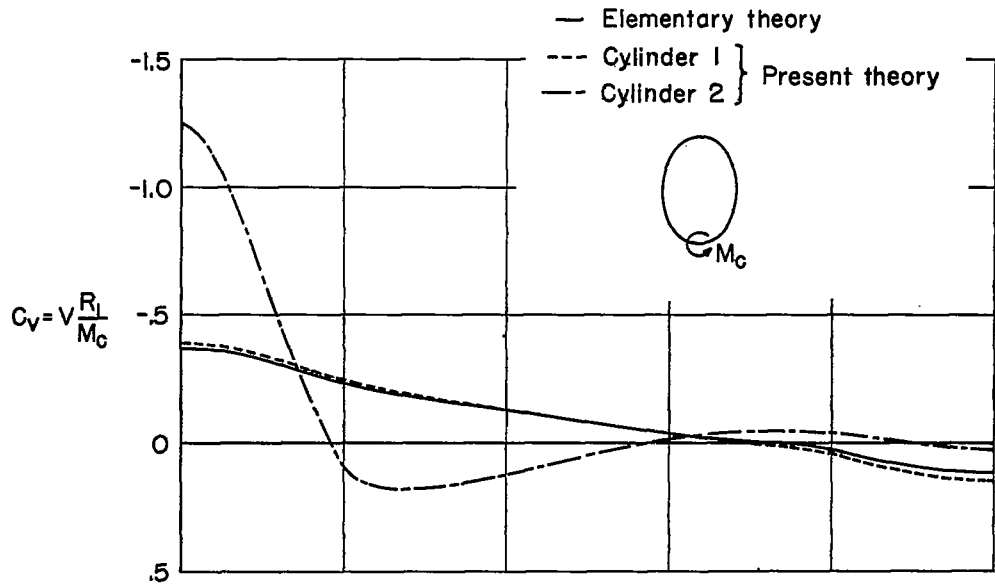

(a) Ring shear force.

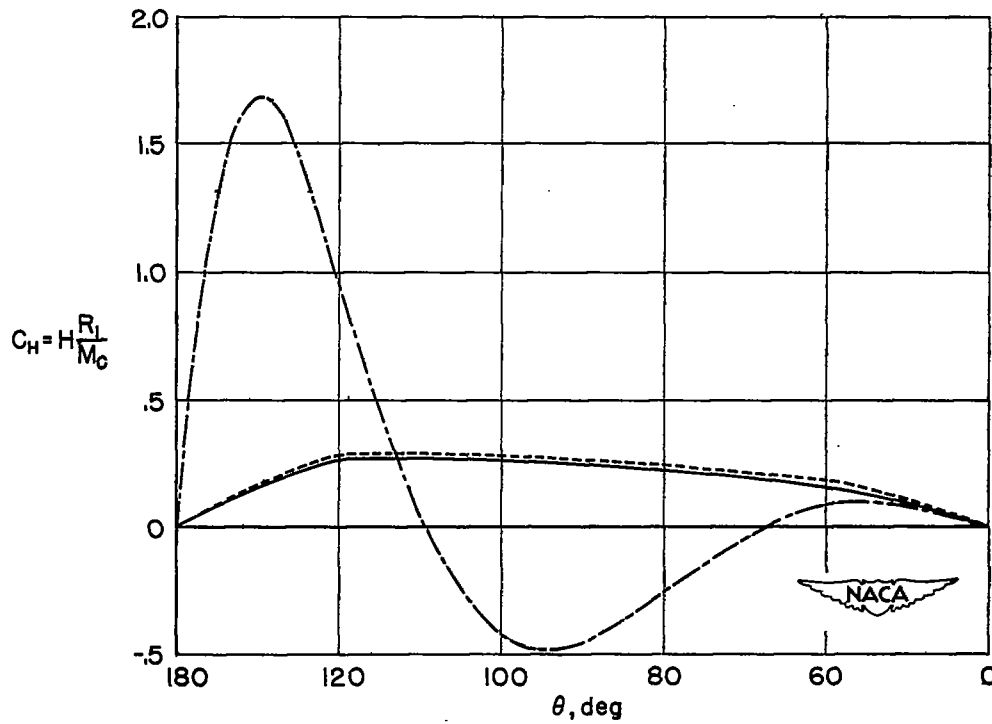

(b) Ring axial force.

Figure 8.— Ring shear- and axial-force distributions produced by concentrated moment load  $M_G$  at  $\theta = 180^\circ$ .

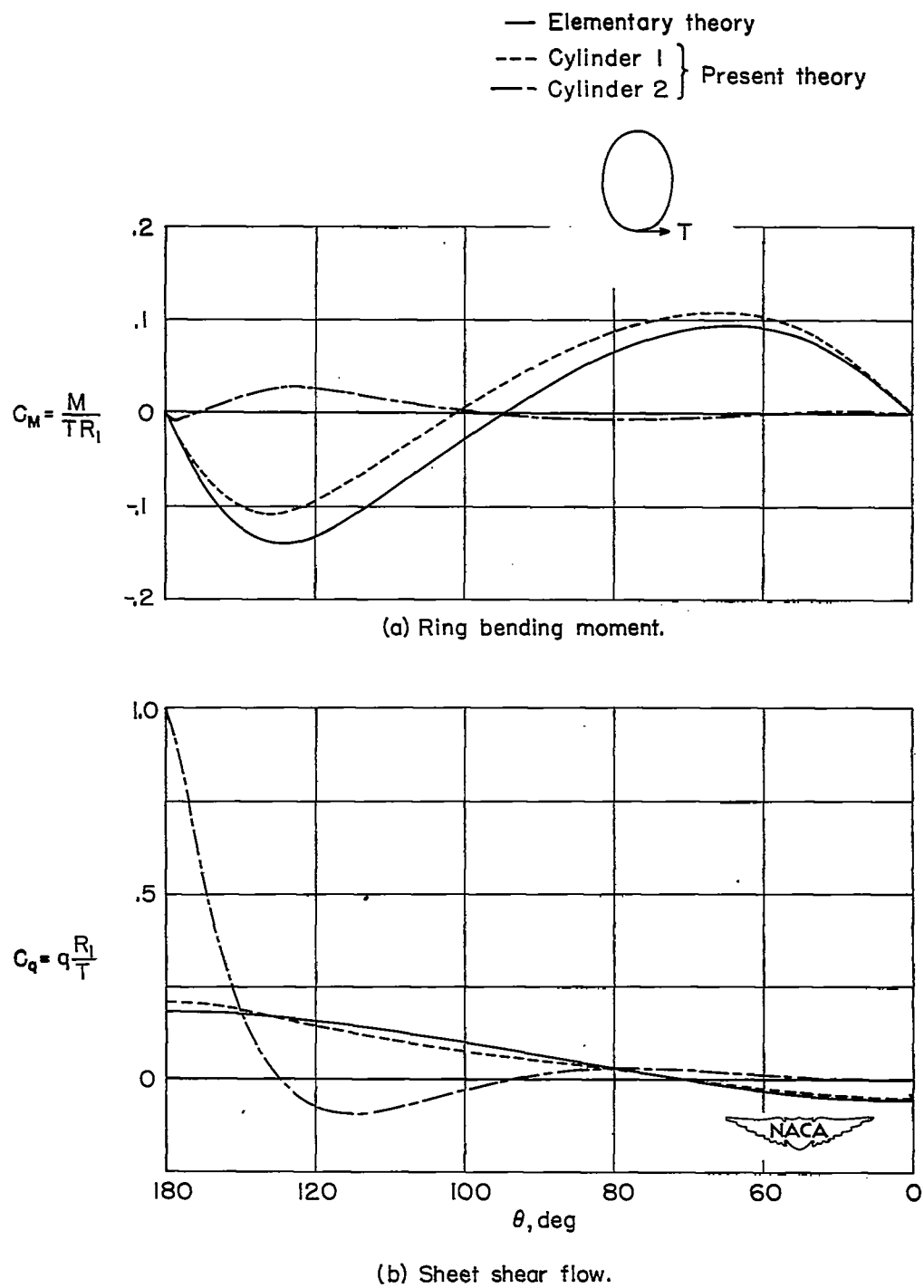

Figure 9.- Bending-moment and shear-flow distributions produced by concentrated tangential load  $T$  at  $\theta = 180^\circ$ .

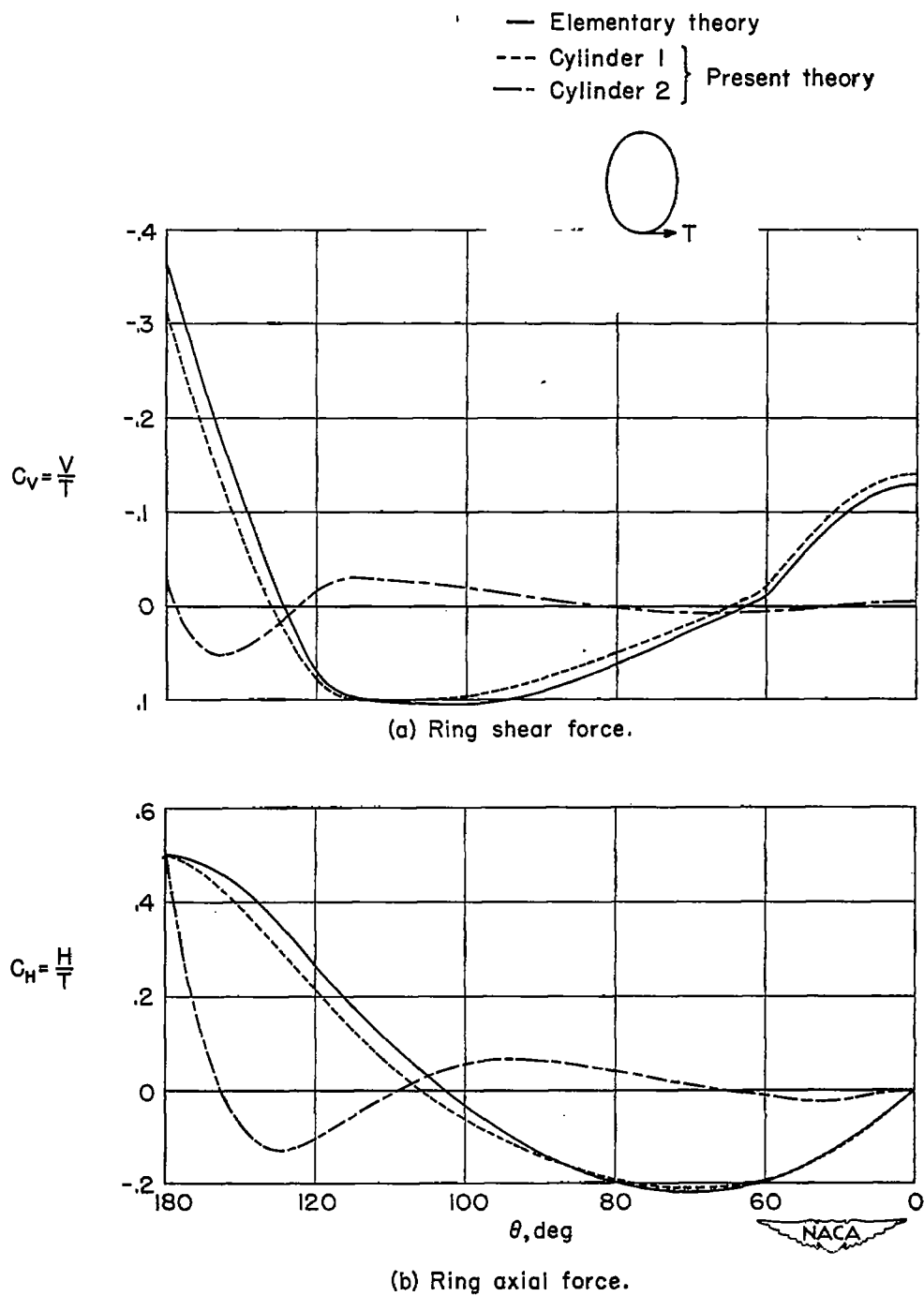

Figure 10.—Ring shear- and axial-force distributions produced by concentrated tangential load  $T$  at  $\theta = 180^\circ$ .