

NACA TN 2792

TN-2792

NATIONAL ADVISORY COMMITTEE FOR AERONAUTICS

TECHNICAL NOTE 2792

DIRECT-READING DESIGN CHARTS FOR 24S-T3 ALUMINUM-ALLOY
FLAT COMPRESSION PANELS HAVING LONGITUDINAL FORMED
HAT-SECTION STIFFENERS AND COMPARISONS WITH
PANELS HAVING Z-SECTION STIFFENERS

By William A. Hickman and Norris F. Dow

Langley Aeronautical Laboratory
Langley Field, Va.

TECHNICAL LIBRARY
AIRESEARCH MANUFACTURING CO.
9851-9951 SE ULVEDA BLVD.
LOS ANGELES 45, CALIF.
CALIFORNIA



Washington
March 1953

ERRATA NO. 1

NACA TN 2792

DIRECT-READING DESIGN CHARTS FOR 24S-T3 ALUMINUM-ALLOY
FLAT COMPRESSION PANELS HAVING LONGITUDINAL FORMED
HAT-SECTION STIFFENERS AND COMPARISONS WITH
PANELS HAVING Z-SECTION STIFFENERS
By William A. Hickman and Norris F. Dow

March 1953

On page 14, the discussion is considerably confused because of the use in a number of places of the phrase "Z-stiffened panel" instead of the correct phrase "Z-section stiffener." This phrase should be corrected in the following lines, all on page 14, so that they read as follows:

- Line 5: "twisting of the Z-section stiffener did not seem to be as serious as the"
- Line 7: "Although the Z-section stiffener always does twist as failure occurs, even"
- Line 13: "of the Z-section stiffener really occurs only after the maximum load has"
- Line 24: "readily be explained, even if twisting of the Z-section stiffener is"
- Lines 26-27: "can be made from Z-stiffened panels by turning every other Z-section stiffener around and joining the outstanding flanges together so that the"

1D NATIONAL ADVISORY COMMITTEE FOR AERONAUTICS

TECHNICAL NOTE 2792

DIRECT-READING DESIGN CHARTS FOR 24S-T3 ALUMINUM-ALLOY

FLAT COMPRESSION PANELS HAVING LONGITUDINAL FORMED

HAT-SECTION STIFFENERS AND COMPARISONS WITH

PANELS HAVING Z-SECTION STIFFENERS

By William A. Hickman and Norris F. Dow

SUMMARY

Direct-reading design charts are presented for 24S-T3 aluminum-alloy flat compression panels having longitudinal formed hat-section stiffeners. These charts make possible the direct determination of the stress and all panel proportions required to carry a given intensity of loading with a given skin thickness and effective length of panel. A comparison is made of the relative merits of hat- and Z-stiffened panels when used for carrying simple compression and when used as the covers of box beams which are subjected to compression plus bending and to compression plus bending plus vertical shear.

INTRODUCTION

Design charts for wing compression panels have been presented in several different forms. (See refs. 1 and 2.) In reference 3, a form was presented which permitted the direct selection of the various panel proportions for given values of the principal design conditions - intensity of loading, skin thickness, and effective length of panel. This form also made possible the ready determination of the proportions having minimum weight to meet these conditions.

In the present paper, similar direct-reading design charts are presented for 24S-T3 aluminum-alloy flat compression panels having longitudinal formed hat-section stiffeners. These charts are based on the extensive test data of references 4 to 6. The structural efficiency of the hat-stiffened panel as evidenced by the charts is then discussed relative to the efficiencies previously found for Z-stiffened panels both when used for carrying simple compression and when used as the covers of box beams which are subjected to compression plus bending and to compression plus bending plus vertical shear.

SYMBOLS

The symbols used for the panel dimensions are given in figure 1. In addition, the following symbols are used:

c	coefficient of end fixity as used in Euler column formula
d	rivet diameter, in.
L	length of panel, in.
p	rivet pitch, in.
P_i	compressive load per inch of panel width, kips/in.
r	all bend radii, in.
\bar{t}	cross-sectional area per inch of panel width, expressed as an equivalent or average thickness, in.
ρ	radius of gyration, in.
$\bar{\sigma}_f$	average stress at failing load, ksi
σ_{cr}	stress for local buckling of sheet, ksi
σ_{cy}	compressive yield stress, ksi

DIRECT-READING DESIGN CHARTS

Direct-reading design charts are presented in two forms in figures 2 to 13 for 24S-T3 aluminum-alloy flat compression panels with longitudinal formed hat-section stiffeners having the properties and proportions given in tables 1 to 7. Values of the ratios of stiffener thickness to skin thickness t_w/t_s , average spacing of rivet lines to skin thickness S/t_s (because there are two rivet lines associated with each hat section, the stiffener spacing b_s plus the distance between rivet lines b_R equals $2S$), and height of stiffener to stiffener thickness H/t_w , which will satisfy a given set of design conditions, may be found directly from these charts, and the corresponding dimensions and section properties b_R/t_w , \bar{t}/t_s , \bar{h}/t_s , and ρ/t_s may be found from tables 2 to 7.

The data on which the design charts are based covered four values of the ratio of stiffener width to stiffener height b_H/b_W , namely 0.6, 0.8, 1.0, and 1.2. Analysis of the results indicated that variations in b_H/b_W were of little significance, just as it was found in reference 2 that variations in the flange widths of Z-sections are of little significance; accordingly, $\frac{b_H}{b_W} = 0.8$ was selected as a representative value and the charts were prepared for this value only. Curves which show how a variation in b_H/b_W affects the section properties are given in figure 14.

First form of design chart.- In the first form of design chart (figs. 2 to 7), the design conditions of intensity of loading, skin thickness, and effective length of panel are incorporated in the ordinate P_i/t_S and the abscissa $\frac{P_i}{L/\sqrt{C}}$. This form, having the design conditions incorporated in the ordinate and abscissa, is more useful than the alternate form for most design purposes because the curves are more widely spaced and interpolation is more straightforward.

Second (alternate) form of design chart.- In the second (alternate) form (figs. 8 to 13), the average stress at failure $\bar{\sigma}_f$ is plotted against P_i/t_S as was done in the summary plots of reference 7. This alternate form, having the stress (an inverse measure of weight for a given load) as ordinate, is more useful for making generalizations and comparisons of structural efficiency than the first form because it indicates how nearly the stress actually carried approaches the upper limit corresponding to the stress that would be achieved by a pure shell construction, if a pure shell could carry the load without failure.

This upper limit of stress is represented by the lines for $\bar{\sigma}_f = \frac{P_i}{t_S}$ (infinite stiffener spacing) in figures 8 to 13.

Color and line conventions used on charts.- Because there are several different quantities presented simultaneously on the design charts, several line and color conventions have been used to distinguish among them. For example, in the first form of design chart (figs. 2 to 7) dashed lines are used to indicate values of average stress at failure $\bar{\sigma}_f$; whereas, on the alternate form of design chart (figs. 8 to 13) dashed lines are used to indicate values of $\frac{P_i}{L/\sqrt{C}}$. In both forms the value of $\bar{\sigma}_f$ corresponding to the point at which each curve is cut by a short heavy line is the value of the stress for local buckling σ_{cr}

for the proportions represented by the curve. For example, the value of σ_{cr} for $\frac{H}{t_W} = 20$ and $\frac{S}{t_S} = 19.9$ in figure 2 is approximately 29 ksi. (Only a very short panel of these proportions would buckle before failure - one having a value of $\frac{P_i}{L/\sqrt{c}} \geq 0.47$.) If the value of σ_{cr} is so low that the short heavy line would fall outside the boundaries of the chart, a numerical value of σ_{cr} is given and is associated with the proper proportions by a leader to the curve. The panel proportions which have minimum weight are indicated on both forms of these charts by the use of colors as follows:

(1) If the proportions correspond to a blue line or region, they are the proportions which give the lightest possible 24S-T3 hat-stiffened panel which will meet the design conditions

(2) If the proportions correspond to a red line or region, they are the proportions which give the lightest possible 24S-T3 hat-stiffened panel at the ratio of stiffener thickness to skin thickness given by that particular chart, but some other thickness ratio would give a lighter design

(3) If the proportions correspond to a white region, the 24S-T3 panel will meet the design conditions but will not be the lightest panel which will meet the conditions

Because in many cases the proportions may be varied somewhat from those indicated by the red and blue colors with little change in the value of the stress that can be carried, too much importance should not be attached to the exact proportions indicated by the colors to have minimum weight. In any particular case for which a deviation from the minimum-weight proportions is made, however, caution dictates that the weight penalty associated with this deviation be determined.

Minimum-weight designs.- As an adjunct to the design charts themselves, the stresses achieved by the panels having the proportions indicated in the design charts to have minimum weight are summarized in figures 15 and 16 for use in weight or efficiency studies. Figure 15 covers the most general case, in which no minimum skin thickness is required. In this case curves of $\bar{\sigma}_F$ plotted against the structural index $\frac{P_i}{L/\sqrt{c}}$ measure the panel structural efficiency. This figure also demonstrates the stated insignificance of a variation in b_H/b_W .

Since the skin thickness of wing compression panels is often fixed by the requirements of adequate torsional stiffness of the wing, curves

which show the effect of a variation in sheet thickness also provide a useful evaluation of the relative structural efficiencies of stiffened panels; accordingly, figure 16 was prepared. In this figure, the average stress corresponding to that for minimum weight (as determined by the procedure given in ref. 7, appendix A) is plotted against the parameter P_i/t_S for a series of values of $\frac{P_i}{L/\sqrt{c}}$ for $\frac{b_H}{b_W} = 0.8$.

USE OF THE DIRECT-READING DESIGN CHARTS

The manner of using the direct-reading design charts depends in some measure on the desired degree of precision of interpolation among the curves. For many purposes, interpolation by inspection is of adequate accuracy, and the use of the charts requires only the calculation of the values of the design parameters P_i/t_S and $\frac{P_i}{L/\sqrt{c}}$ to permit the desired proportions to be read directly from the curves. The proportions for minimum weight, moreover, may be found directly as those corresponding to the blue region of the curves.

If more accurate interpolation is desired, a plot can readily be made of H/t_W , $\bar{\sigma}_f$, and σ_{cr} against S/t_S at the given values of P_i/t_S and $\frac{P_i}{L/\sqrt{c}}$ and the proportions can be picked from it. (This plot is similar to that which results from the use of the minimum-weight design procedure with the previously available design charts, refs. 2 and 7.) On a plot of this type, the proportions for minimum weight correspond to those associated with the highest value of $\bar{\sigma}_f$.

As a check on the accuracy of interpolation, the cross-sectional area per inch of width of the design may be determined from the values of T/t_S given in tables 2 to 7, and the value of the intensity of loading P_i that can be carried on this cross-sectional area per inch at the value $\bar{\sigma}_f$ given by the charts may then be compared with the design value of P_i .

The value of $\bar{\sigma}_f$ obtained from the design charts can be achieved only if the panels are riveted with large-diameter closely spaced rivets that have essentially the same strength characteristics as the Al7S-T4 aluminum-alloy rivets used for the test specimens of references 5 and 6. Reference 8, which presents curves for determining the rivet diameter and pitch required to insure the development of a given average

stress for local instability, may be used as a guide for determining the effect of variations in riveting. Whereas the data of reference 8 are for Al7S-T4 flat-head rivets (AN442AD), references 9 and 10 show that the NACA flush rivet, which was used for the hat-stiffened panels, compares very favorably in strength with a flat- or round-head rivet.

ILLUSTRATIVE EXAMPLES

In order to illustrate the use of the direct-reading design charts and the simplicity of the computations associated with them, two panels are designed from them. The first panel design illustrates the simple case for which interpolation is not a problem. The second design illustrates possible difficulties in interpolation which may be encountered.

First example (interpolation straightforward).- For the first example a panel is designed for minimum weight to meet the following principal design conditions, namely:

- (1) Intensity of loading $P_i = 4.0$ kips per inch
- (2) Skin thickness $t_S = 0.064$ inch
- (3) Effective length $\frac{L}{\sqrt{c}} = 20$ inches

First the values of P_i/t_S and $\frac{P_i}{L/\sqrt{c}}$ are calculated as follows:

$$\frac{P_i}{t_S} = \frac{4.0}{0.064} = 62.5 \text{ ksi}$$

$$\frac{P_i}{L/\sqrt{c}} = \frac{4.0}{20} = 0.20 \text{ ksi}$$

Then a trial value of stiffener thickness to skin thickness t_W/t_S is assumed. If desired, figure 16 may be used to aid in the selection of a suitable ratio of stiffener thickness to skin thickness. For the example, however, in order to illustrate the use of the charts when a nonoptimum thickness ratio is chosen, $\frac{t_W}{t_S} = 1.25$ is used. In the

chart for this value of t_W/t_S (fig. 7), the points corresponding to the design values of P_i/t_S and $\frac{P_i}{L/\sqrt{c}}$ lie in the red region at $\frac{H}{t_W} = 20$ (or $\frac{b_W}{t_W} = 19$). Accordingly, the value of H/t_W for minimum weight for $\frac{t_W}{t_S} = 1.25$ is 20, and because the value is established by a red region, not a blue one, some value of t_W/t_S other than 1.25 will give less weight.

Inspection of the charts for other values of t_W/t_S reveals that the points for the given design values of P_i/t_S and $\frac{P_i}{L/\sqrt{c}}$ fall on a blue line at $\frac{H}{t_W} = 30$ on the chart for $\frac{t_W}{t_S} = 0.79$ (fig. 5). The panel proportions corresponding to this blue line are $\frac{H}{t_W} = 30$ (or $\frac{b_W}{t_W} = 29$) and $\frac{S}{t_S} \approx 32.5$ (or $\frac{b_S}{t_S} \approx 34$), and for these proportions $\bar{\sigma}_F \approx 30.5$ ksi and $\sigma_{CR} \approx 26$ ksi, which are the values for minimum weight. The actual panel dimensions can be calculated from these proportions as

$$\begin{aligned} t_W &= \frac{t_W}{t_S} t_S \\ &= 0.79 \times 0.064 = 0.051 \text{ in.} \end{aligned}$$

$$\begin{aligned} H &= \frac{H}{t_W} t_W \\ &= 30 \times 0.051 = 1.53 \text{ in.} \end{aligned}$$

$$\begin{aligned} S &= \frac{S}{t_S} t_S \\ &= 32.5 \times 0.064 = 2.08 \text{ in.} \end{aligned}$$

and the section properties can be determined from table 5 as

$$\begin{aligned}\bar{h} &= \frac{\bar{h}}{t_S} t_S \\ &= 6.21 \times 0.064 = 0.397 \text{ in.}\end{aligned}$$

$$\begin{aligned}\rho &= \frac{\rho}{t_S} t_S \\ &= 8.58 \times 0.064 = 0.549 \text{ in.}\end{aligned}$$

As a check on the accuracy of interpolation, the magnitude of \bar{t}/t_S for these proportions can be determined from table 5 and multiplied by the values of t_S and $\bar{\sigma}_f$ for the design. This product should be equal to the design value of P_i . For the example

$$\bar{\sigma}_f = 30.5 \text{ ksi}$$

$$\frac{\bar{t}}{t_S} = 2.05$$

therefore

$$\begin{aligned}P_i &= \bar{\sigma}_f \bar{t} \\ &= \bar{\sigma}_f \frac{\bar{t}}{t_S} t_S \\ &= 30.5 \times 2.05 \times 0.064 = 4.0 \text{ kips/in.}\end{aligned}$$

which agrees with the design value of P_i originally assumed.

Second example (interpretation of interpolation difficult).- Because of the wide range of proportions covered in this panel program, each figure in the design charts must also cover a wide range of proportions. Because an increase in the size of the charts over that previously used

did not seem desirable, the change in proportions from plot to plot within the charts was increased; consequently, interpolation has to be made within wider gaps and hence is less straightforward. Moreover, the position of the blue and red regions shifts considerably from plot to plot to correspond to the substantial change in proportions, and, therefore, interpolation to determine the region in which the minimum-weight design lies also may be difficult in some cases.

Possible difficulties of interpolation and a typical solution are demonstrated by the following example. Assume that a panel design for minimum weight is required to meet these design conditions, namely:

$$(1) P_i = 3.0 \text{ kips per inch}$$

$$(2) t_S = 0.051 \text{ inch}$$

$$(3) \frac{L}{\sqrt{c}} = 18 \text{ inches}$$

From these design conditions, values of P_i/t_S and $\frac{P_i}{L/\sqrt{c}}$ may be calculated as follows:

$$\frac{P_i}{t_S} = \frac{3.0}{0.051} = 58.8 \text{ ksi}$$

$$\frac{P_i}{L/\sqrt{c}} = \frac{3.0}{18} = 0.167 \text{ ksi}$$

The point on the summary plot (fig. 16) corresponding to these values of P_i/t_S and $\frac{P_i}{L/\sqrt{c}}$ appears by visual interpolation to fall on the boundary between the regions for which values of t_W/t_S of 0.79 and 1.00 are most efficient. Accordingly, both figures 5 and 6 for values of t_W/t_S of 0.79 and 1.00, respectively, will be used in order to find which one yields the lighter design.

In figure 5, the points corresponding to the design values of P_i/t_S and $\frac{P_i}{L/\sqrt{c}}$ lie above a blue line at $\frac{H}{t_W} = 30$ and below a red

line at $\frac{H}{t_W} = 40$. In figure 6, the corresponding points are above a red line at $\frac{H}{t_W} = 25$ and below a blue line at $\frac{H}{t_W} = 30$. An interpolated value for $\frac{t_W}{t_S} = 0.79$ might have the following proportions

$$\frac{H}{t_W} = 32$$

$$\frac{b_S}{t_S} = 36$$

and develop a stress $\bar{\sigma}_f = 29$ ksi. Corresponding values for $\frac{t_W}{t_S} = 1.00$ might be

$$\frac{H}{t_W} = 26$$

$$\frac{b_S}{t_S} = 54$$

and

$$\bar{\sigma}_f = 29 \text{ ksi}$$

As might be deduced from the fact that the charts do not indicate an advantage for either a thickness ratio of 0.79 or 1.00, there is

little difference in the stress that can be carried for $\frac{t_W}{t_S} = 0.79$

or 1.00. In fact, the difference is smaller than can be detected accurately by visual interpolation. The accuracy of interpolation can be improved by making a plot of H/t_W and $\bar{\sigma}_f$ against S/t_S as has been done for this example in figure 17. From this plot, the minimum-weight design conditions corresponding to the maximums of the curves of $\bar{\sigma}_f$ plotted against S/t_S for $\frac{t_W}{t_S} = 0.79$ are found to be

$$\frac{H}{t_W} = 30.8 \quad \left(\text{or} \quad \frac{b_W}{t_W} = 29.8 \right)$$

$$\frac{S}{t_S} = 33.6 \quad \left(\text{or} \quad \frac{b_S}{t_S} = 36 \right)$$

$$\bar{\sigma}_f = 29.2 \text{ ksi}$$

and

$$\sigma_{cr} = 24.8 \text{ ksi}$$

The panel dimensions can be calculated from these proportions as

$$\begin{aligned} t_W &= \frac{t_W}{t_S} t_S \\ &= 0.79 \times 0.051 = 0.040 \text{ in.} \end{aligned}$$

$$\begin{aligned} H &= \frac{H}{t_W} t_W \\ &= 30.8 \times 0.040 = 1.23 \text{ in.} \end{aligned}$$

$$\begin{aligned} S &= \frac{S}{t_S} t_S \\ &= 33.6 \times 0.051 = 1.71 \text{ in.} \end{aligned}$$

and the section properties are

$$\begin{aligned} \bar{h} &= \frac{\bar{h}}{t_S} t_S \\ &= 6.35 \times 0.051 = 0.324 \text{ in.} \end{aligned}$$

$$\begin{aligned}\rho &= \frac{p}{t_S} t_S \\ &= 8.81 \times 0.051 = 0.450 \text{ in.}\end{aligned}$$

As a check on the accuracy of interpolation, the same procedure as followed in the previous section may be used; that is,

$$\begin{aligned}P_i &= \bar{\sigma}_f \bar{t} \\ &= \bar{\sigma}_f \frac{\bar{t}}{t_S} t_S \\ &= 29.2 \times 2.02 \times 0.051 = 3.0 \text{ kips/in.}\end{aligned}$$

For $\frac{t_W}{t_S} = 1.00$, the minimum-weight design conditions are

$$\frac{H}{t_W} = 25.6 \quad \left(\text{or} \quad \frac{b_W}{t_W} = 24.6 \right)$$

$$\frac{S}{t_S} = 45 \quad \left(\text{or} \quad \frac{b_S}{t_S} = 55.4 \right)$$

$$\bar{\sigma}_f = 28.6 \text{ ksi}$$

and

$$\sigma_{cr} = 18.3 \text{ ksi}$$

Thus

$$\begin{aligned}t_W &= \frac{t_W}{t_S} t_S \\ &= 1.00 \times 0.051 = 0.051 \text{ in.}\end{aligned}$$

$$\begin{aligned} H &= \frac{H}{t_W} t_W \\ &= 25.6 \times 0.051 = 1.30 \text{ in.} \end{aligned}$$

$$\begin{aligned} S &= \frac{S}{t_S} t_S \\ &= 45 \times 0.051 = 2.29 \text{ in.} \end{aligned}$$

The section properties are

$$\begin{aligned} \bar{h} &= \frac{\bar{h}}{t_S} t_S \\ &= 6.94 \times 0.051 = 0.354 \text{ in.} \end{aligned}$$

$$\begin{aligned} \rho &= \frac{\rho}{t_S} t_S \\ &= 9.58 \times 0.051 = 0.489 \text{ in.} \end{aligned}$$

As a check,

$$\begin{aligned} P_i &= \bar{\sigma}_f \bar{t} \\ &= \bar{\sigma}_f \frac{\bar{t}}{t_S} t_S \\ &= 28.6 \times 2.05 \times 0.051 = 3.0 \text{ kips/in.} \end{aligned}$$

COMPARISONS OF HAT- AND Z-STIFFENED PANELS

Simple compression. - Previous comparisons (refs. 4 and 5) have made the characteristics of the hat-stiffened panel appear disappointing relative to the Z-stiffened panel despite the inherent stability of the hat-stiffened panel against twisting. For straight compression, the twisting of the Z-stiffened panel did not seem to be as serious as the typically twisted appearance of failed specimens (fig. 18) would suggest. Although the Z-stiffened panel always does twist as failure occurs, even when its proportions are definitely such that failure is precipitated by some mode of distortion other than twisting, the twisted appearance of failed specimens was evidently misleading. The indications were that, for a much wider range of proportions than had been realized (including those which are structurally efficient), destructive twisting of the Z-stiffened panel really occurs only after the maximum load has been reached.

The failure of the hat-stiffened panel to be structurally superior to the Z-stiffened panel at low values of the parameter P_i/t_S (see fig. 16) can readily be accounted for by the fact that at low values of P_i/t_S - that is, at relatively large values of t_S which must be accompanied by wide stiffener spacings - only stiffeners like Z-sections having one rivet line per stiffener can readily be spaced to support the sheet at equal intervals. On the other hand, the reason why there are not at least some proportions for which hat-stiffened panels are more efficient in compression than Z-stiffened panels cannot so readily be explained, even if twisting of the Z-stiffened panel is not serious - specifically, proportions for which hat-stiffened panels can be made from Z-stiffened panels by turning every other Z-stiffened panel around and joining the outstanding flanges together so that the sheet is left supported at equal intervals. If the hat section is considered to buckle as a rectangular tube buckles, it should buckle at a higher stress than the Z- or channel section which is one-half the rectangular tube. For example, the coefficient k in the plate-buckling formula for a rectangular tube 0.8 as wide as it is high is given in reference 11 as approximately 4.63; whereas the k -value for a Z-section with a flange-to-web-width ratio of 0.4 is given as only 3.74. In the high-stress region of close stiffener spacings where buckling and failure coincide, therefore, the hat section should be superior to the Z-section. Because the tests reported in references 4 to 6 did not cover hat-stiffened panels having such close stiffener spacings and because the details of construction used for the hat-stiffened panels of those references may have been unfavorable to the hat-stiffened panel, the precisely equivalent hat- and Z-stiffened panels shown in figure 19 were constructed and tested in order to

investigate this possible superiority of closely spaced hat sections. Details of construction of the Z-stiffened panels were the same as those of the panels of reference 2 and were identical with the details of construction (bend radii, widths of attachment flanges, and riveting) of the corresponding six hat-stiffened panels. The proportions were chosen in order to achieve relatively high stresses and relatively high structural efficiencies. (At values of $\frac{P_i}{L/\sqrt{c}}$ of 0.12 and 0.30 ksi, respectively, the charts of reference 2 indicate that there are no more efficient 24S-T3 aluminum-alloy Z-stiffened panel cross sections than the two investigated.)

The twelve comparative hat- and Z-stiffened panels were compressed flat-ended in the same manner as in other NACA panel tests. The results are given in table 8(a).

The data of table 8(a) show that the hat-stiffened panels were at best 11 to 13 percent stronger than the equivalent Z-stiffened panels. In other words, for the proportions for which the hat-section panel appears best suited -- that is, for those proportions for which the sheet is supported at equal close intervals so that high stresses are achieved -- the hat-stiffened panel is somewhat superior structurally to the Z-stiffened panel for carrying simple compression.

Combined compression and bending. - Questions have arisen as to whether, when the stiffened panel is used as the cover of a box beam subjected to shear and bending combined with compression, the twisting of the Z-section does not become more serious than in simple compression. Hat-stiffened panels have been used in some cases in preference to Z-stiffened panels simply because of uncertainty about the twisting of the Z-section under such conditions of combined loads. Actually, the effect of such bending superposed on compression is to some extent covered by the data already published on which the design charts of references 12 and 13 are based. The test panels from which these data were obtained always bent toward the skin as the compressive load was increased because of initial bow induced by the rivets which expanded the skin as they were driven. At the center of the panel where there is a maximum of twisting this initial bow induced a compressive stress in the outstanding flanges of the Z-sections which was higher than the average stress on the cross section. At the center of a Z-stiffened panel in the compression surface of the wing, the stress in the outstanding flanges tends to be: (1) reduced below the average stress on the cross section because the flanges are nearer the neutral axis of the wing than the centroidal axis of the panel cross section and (2) increased above the average stress on the cross section by the bending between ribs caused by the local air loads. For example, if the design illustrative of the use of the charts of reference 12 was located in the upper surface of a wing having its neutral axis 6 inches

from the centroidal axis of the panel and the local air load was 5 psi, the stress in the outstanding flanges in the center of the panel would be: (1) reduced by not more than 5.1 ksi by the proximity of the flanges to the neutral axis of the wing and (2) increased by approximately 5.7 ksi by the local-air-load bending. The resulting slight increase in stress is similar to that caused by the initial bow in the test specimens and appears unlikely to cause much more severe twisting of the Z-sections than occurred in the compressive tests. The best comparable hat-panel design for this example is far removed from the proportions for which the sheet is supported at equal close intervals. Accordingly, here the hat section is inefficient, as indicated in figure 15 which shows that, at the design values of $\frac{P_i}{t_S} = 47$ ksi and $\frac{P_i}{L/\sqrt{c}} = 0.15$ ksi, the hat-stiffened panel can at best achieve a stress 10 percent below the value of 30.5 ksi indicated by figure 19 of reference 7 to be achievable by a Z-stiffened panel. Hence, twisting has to be appreciably more serious than that found in compression before the hat-stiffened panel can become more efficient than the Z-stiffened panel, at least for the conditions of the example and for similar conditions encountered in practice.

In order to study more thoroughly the effect of bending combined with compression, the box beams shown in figure 20 were constructed and tested. The compression covers of these beams were made up of equivalent hat- and Z-stiffened panels of the same cross sections as those used for the previous compressive comparison. The boxes were tested in combined bending and compression in the combined load testing machine of the Langley structures research laboratory with the compression covers bearing flat-ended against the testing machine platens as in previous compression tests and the ratio of bending moment to compression maintained to keep the distance from the centroid of the panel cross section to the neutral axis of the beam between 1 and 1.5 times the stiffener height. The lengths of the boxes were the same as the lengths of the longest compression specimens of table 8(a). The results of the box-beam bending tests are given in table 8(b).

The stresses at the centroids of the panel cross sections at the maximum loads carried in the box-beam bending tests, as calculated by the $\frac{Mc}{I}$ - formula and confirmed by strain-gage measurements, were within ± 9 percent of the corresponding values obtained in the compression tests. There was no evidence that the Z-section was made less efficient by the bending combined with the compression; in fact, the Z-stiffened panels were relatively better, compared with the hat-stiffened panels in these bending tests, than they were in simple compression.

Combined compression, bending, and shear.- The effects of vertical shear combined with bending and compression on a box beam with a stiffened

panel used as the cover are more complicated to investigate than simple bending and compression alone because the stress in the panel varies along its length and the effect of the gradient of the stress must be considered along with the effect of the shear. Four additional boxes, duplicates of those tested in bending, were tested in bending plus vertical shear to make the stress gradient such that the stresses at one end of the beam were 25 percent higher than those at the other end of the beam. The results are given in table 8(c). The maximum stresses at the panel centroids at maximum load were in every case in excess of those for the pure bending case. The Z-stiffened panels as compared with the hat-stiffened panels were even better under the combined loads than in simple bending.

Loading conditions and stiffener configurations not yet considered.-
The effects of local air load and torsion on the box of which the stiffened panel is the cover are still to be evaluated experimentally. No clear reason is evident at present why the local air load should be more harmful to either the hat- or the Z-stiffened panels. For torsion, the hat section would appear to have advantages over the Z-section because of the ability of the hat section to relieve some of the shear stress in the skin underneath it. Whether these advantages would be significant would depend upon the ability of the sheet between the hat section to carry the shear, thus, the hat-stiffened panel would appear best suited for applications involving close stiffener spacings.

When the spaces between hat sections are appreciably greater than those under the hat sections - as they are more likely to be the thicker skinned the construction - the hat section is at a disadvantage relative to the Z-section because the Z-sections can be spaced on the skin at equal intervals. This inherent advantage of the Z-stiffened panel has been noted in previous structural-efficiency comparisons (refs. 4 and 5), and the present box-beam tests have produced no evidence to show that the advantage will disappear when the Z-stiffened panel is used as the cover of such a beam subjected to bending or to bending plus vertical shear rather than to simple compression.

CONCLUDING REMARKS

Structural evaluations of hat-section stiffeners, together with the direct-reading charts presented herewith for designing hat-stiffened panels, have indicated that the hat-section stiffener is structurally better than the Z-section stiffener for only a limited range of applications at best. For carrying simple compression, and when used as the covers of box beams which are subjected to compression plus bending or to compression plus bending plus vertical shear, the Z-stiffened panel

compared very favorably with the hat-stiffened panel, even in the range of close stiffener spacings for which the hat section is best suited.

Langley Aeronautical Laboratory,
National Advisory Committee for Aeronautics,
Langley Field, Va., May 20, 1952.

REFERENCES

1. Langhaar, Henry L.: Design of Hat-Type Plate-Stringer Combinations. Auto. and Aviation Ind., vol. 91, no. 11, Dec. 1, 1944, pp. 28-32 and 103-104.
2. Schuette, Evan H.: Charts for the Minimum-Weight Design of 24S-T Aluminum-Alloy Flat Compression Panels With Longitudinal Z-Section Stiffeners. NACA Rep. 827, 1945. (Supersedes NACA ARR L5F15.)
3. Dow, Norris F., and Hickman, William A.: Direct-Reading Design Charts for 75S-T Aluminum-Alloy Flat Compression Panels Having Longitudinal Straight-Web Y-Section Stiffeners. NACA TN 1640, 1948.
4. Schuette, Evan H., Barab, Saul, and McCracken, Howard L.: Compressive Strength of 24S-T Aluminum-Alloy Flat Panels With Longitudinal Formed Hat-Section Stiffeners. NACA TN 1157, 1946.
5. Hickman, William A., and Dow, Norris F.: Compressive Strength of 24S-T Aluminum-Alloy Flat Panels With Longitudinal Formed Hat-Section Stiffeners Having a Ratio of Stiffener Thickness to Skin Thickness Equal to 1.00. NACA TN 1439, 1947.
6. Hickman, William A., and Dow, Norris F.: Compressive Strength of 24S-T Aluminum-Alloy Flat Panels With Longitudinal Formed Hat-Section Stiffeners Having Four Ratios of Stiffener Thickness to Skin Thickness. NACA TN 1553, 1948.
7. Dow, Norris F., and Hickman, William A.: Design Charts for Flat Compression Panels Having Longitudinal Extruded Y-Section Stiffeners and Comparison With Panels Having Formed Z-Section Stiffeners. NACA TN 1389, 1947.
8. Dow, Norris F., and Hickman, William A.: Effect of Variation in Rivet Diameter and Pitch on the Average Stress at Maximum Load for 24S-T3 and 75S-T6 Aluminum-Alloy, Flat, Z-Stiffened Panels That Fail by Local Instability. NACA TN 2139, 1950.
9. Rossman, Carl A., and Schuette, Evan H.: Data on Compressive Strength of Flat Panels With Z-Section Stiffeners. NACA RB, Sept. 1942.
10. Dow, Norris F., and Hickman, William A.: Preliminary Investigation of the Relation of the Compressive Strength of Sheet-Stiffener Panels to the Diameter of Rivet Used for Attaching Stiffeners to Sheet. NACA RB L4I13, 1944.

11. Stowell, Elbridge Z., Heimerl, George J., Libove, Charles, and Lundquist, Eugene E.: Buckling Stresses for Flat Plates and Sections. Proc. A.S.C.E., vol. 77, separate no. 77, July 1951, pp. 1-31.
12. Dow, Norris F., and Keevil, Albert S., Jr.: Direct-Reading Design Charts for 24S-T Aluminum-Alloy Flat Compression Panels Having Longitudinal Formed Z-Section Stiffeners. NACA TN 1778, 1949.
13. Hickman, William A., and Dow, Norris F.: Direct-Reading Design Charts for 75S-T6 Aluminum-Alloy Flat Compression Panels Having Longitudinal Extruded Z-Section Stiffeners. NACA TN 2435, 1952.

TABLE 1.- TYPICAL MATERIAL PROPERTIES OF 24S-T3 ALUMINUM-ALLOY
PANELS HAVING FORMED HAT-SECTION STIFFENERS ON
WHICH DESIGN CHARTS ARE BASED

	Material properties	
	Aluminum alloy	σ_{cy} , ksi
Sheet	24S-T3 bare	43.8
Stiffeners	24S-T3 bare sheet before forming	44.3



TABLE 2.- HAT-PANEL PROPERTIES $\left[\frac{t_W}{t_S} = 0.40; \frac{b_H}{b_W} = 0.8; \frac{b_A}{t_W} = 20.75; \frac{b_H}{t_W} = 0.8 \frac{b_W}{t_W}; \frac{b_R}{t_W} = 0.8 \frac{b_W}{t_W} + 20.25; \frac{r}{t_W} = 3.13; \frac{d}{t_S} = 1.84; \frac{p}{t_S} = 9.80 \right]$

$\frac{b_W}{t_S}$	$\frac{b_W}{t_W}$	19	21	23	24	25	27	29	31	33	35	37	39	41	43	45	47	49	51	53	55	57	59
23		1.384	1.401	1.418	1.426	1.434	1.450	1.466	1.480	1.495	1.509	1.523	1.536	1.548	1.561	1.573	1.585	1.596	1.607	1.618	1.629	1.639	1.649
24		1.373	1.391	1.407	1.415	1.423	1.439	1.454	1.469	1.483	1.497	1.510	1.524	1.536	1.549	1.561	1.572	1.584	1.595	1.605	1.616	1.626	1.636
25		1.364	1.381	1.397	1.405	1.413	1.428	1.443	1.458	1.472	1.486	1.499	1.512	1.525	1.537	1.549	1.560	1.572	1.579	1.593	1.604	1.614	1.624
26		1.355	1.371	1.387	1.395	1.403	1.418	1.433	1.447	1.461	1.475	1.488	1.501	1.513	1.525	1.537	1.549	1.560	1.571	1.581	1.592	1.602	1.612
27		1.346	1.362	1.378	1.386	1.394	1.409	1.423	1.437	1.451	1.465	1.478	1.490	1.501	1.515	1.526	1.538	1.549	1.560	1.570	1.581	1.591	1.600
28		1.338	1.354	1.369	1.377	1.385	1.400	1.414	1.428	1.441	1.455	1.467	1.480	1.492	1.504	1.516	1.527	1.538	1.549	1.559	1.570	1.580	1.589
29		1.330	1.346	1.361	1.369	1.376	1.391	1.405	1.419	1.432	1.444	1.458	1.470	1.482	1.494	1.506	1.517	1.528	1.538	1.548	1.559	1.567	1.579
30		1.322	1.338	1.353	1.361	1.368	1.382	1.396	1.408	1.423	1.436	1.449	1.461	1.473	1.484	1.496	1.507	1.518	1.528	1.539	1.549	1.559	1.568
31		1.315	1.331	1.345	1.353	1.360	1.374	1.388	1.401	1.414	1.427	1.440	1.452	1.464	1.475	1.487	1.498	1.508	1.519	1.529	1.539	1.549	1.559
32		1.308	1.323	1.338	1.345	1.352	1.366	1.380	1.397	1.406	1.419	1.431	1.443	1.455	1.466	1.477	1.488	1.499	1.510	1.520	1.530	1.539	1.549
33		1.302	1.317	1.331	1.338	1.345	1.359	1.372	1.386	1.398	1.411	1.423	1.435	1.446	1.458	1.469	1.480	1.490	1.501	1.511	1.521	1.530	1.540
34		1.295	1.310	1.324	1.331	1.338	1.352	1.365	1.378	1.391	1.403	1.415	1.427	1.438	1.449	1.460	1.471	1.482	1.492	1.502	1.512	1.521	1.531
35		1.289	1.304	1.318	1.325	1.332	1.345	1.358	1.371	1.386	1.396	1.407	1.419	1.430	1.441	1.452	1.463	1.473	1.484	1.494	1.503	1.513	1.522
36		1.284	1.298	1.312	1.318	1.325	1.338	1.351	1.364	1.376	1.388	1.400	1.412	1.423	1.434	1.445	1.455	1.465	1.475	1.485	1.495	1.505	1.514
37		1.278	1.292	1.306	1.312	1.319	1.332	1.345	1.357	1.369	1.381	1.393	1.404	1.415	1.426	1.437	1.447	1.458	1.468	1.477	1.487	1.496	1.506
38		1.273	1.286	1.300	1.306	1.313	1.326	1.339	1.351	1.363	1.375	1.386	1.397	1.408	1.418	1.430	1.440	1.450	1.460	1.470	1.479	1.489	1.498
39		1.267	1.281	1.294	1.301	1.307	1.320	1.333	1.345	1.357	1.368	1.380	1.391	1.402	1.412	1.423	1.433	1.443	1.452	1.462	1.472	1.481	1.490
40		1.262	1.276	1.289	1.295	1.302	1.314	1.327	1.339	1.350	1.362	1.373	1.384	1.395	1.406	1.416	1.426	1.436	1.446	1.455	1.465	1.474	1.483
42		1.253	1.266	1.279	1.285	1.291	1.304	1.316	1.327	1.339	1.350	1.361	1.372	1.382	1.392	1.403	1.413	1.423	1.432	1.442	1.451	1.460	1.469
44		1.244	1.257	1.269	1.276	1.282	1.294	1.305	1.317	1.328	1.339	1.350	1.360	1.371	1.381	1.391	1.401	1.410	1.419	1.429	1.438	1.447	1.455
46		1.236	1.249	1.261	1.267	1.273	1.284	1.296	1.307	1.318	1.328	1.339	1.349	1.359	1.369	1.379	1.389	1.398	1.407	1.417	1.425	1.434	1.443
48		1.229	1.241	1.252	1.258	1.264	1.275	1.286	1.297	1.308	1.319	1.329	1.339	1.349	1.359	1.368	1.378	1.387	1.396	1.405	1.414	1.422	1.431
50		1.221	1.233	1.245	1.250	1.256	1.267	1.278	1.289	1.299	1.314	1.319	1.329	1.338	1.349	1.361	1.367	1.376	1.385	1.394	1.403	1.411	1.420
52		1.215	1.226	1.237	1.243	1.248	1.259	1.270	1.280	1.291	1.301	1.311	1.320	1.330	1.339	1.348	1.358	1.366	1.375	1.384	1.392	1.401	1.409
54		1.208	1.219	1.230	1.236	1.244	1.252	1.262	1.272	1.282	1.292	1.302	1.312	1.321	1.330	1.339	1.348	1.357	1.366	1.374	1.382	1.391	1.399
56		1.202	1.213	1.224	1.229	1.235	1.245	1.255	1.265	1.275	1.285	1.294	1.303	1.314	1.322	1.331	1.339	1.348	1.356	1.365	1.373	1.381	1.389
58		1.197	1.207	1.218	1.223	1.228	1.238	1.248	1.258	1.268	1.277	1.286	1.296	1.305	1.314	1.322	1.331	1.339	1.348	1.356	1.364	1.372	1.380
60		1.191	1.202	1.212	1.217	1.222	1.232	1.242	1.251	1.261	1.270	1.279	1.288	1.297	1.306	1.314	1.323	1.331	1.339	1.348	1.355	1.363	1.371
63		1.184	1.194	1.204	1.209	1.212	1.223	1.233	1.242	1.251	1.260	1.269	1.278	1.286	1.295	1.303	1.321	1.320	1.328	1.336	1.343	1.351	1.359
66		1.177	1.187	1.196	1.201	1.206	1.215	1.224	1.233	1.242	1.251	1.260	1.268	1.277	1.285	1.293	1.301	1.309	1.317	1.324	1.332	1.340	1.347
69		1.171	1.180	1.189	1.194	1.199	1.208	1.216	1.225	1.234	1.242	1.251	1.259	1.267	1.275	1.283	1.291	1.299	1.307	1.314	1.321	1.329	1.336
72		1.165	1.174	1.183	1.187	1.192	1.201	1.209	1.218	1.226	1.234	1.243	1.251	1.259	1.267	1.274	1.282	1.289	1.297	1.304	1.312	1.319	1.326
75		1.159	1.168	1.177	1.181	1.185	1.194	1.202	1.211	1.219	1.227	1.235	1.243	1.251	1.258	1.266	1.273	1.281	1.288	1.295	1.302	1.309	1.316
78		1.154	1.163	1.171	1.175	1.179	1.188	1.196	1.204	1.212	1.220	1.228	1.235	1.242	1.250	1.258	1.265	1.272	1.279	1.286	1.293	1.300	1.307
81		1.149	1.157	1.166	1.170	1.174	1.182	1.190	1.198	1.206	1.213	1.221	1.228	1.236	1.243	1.250	1.257	1.264	1.271	1.278	1.285	1.292	1.298
84		1.144	1.153	1.161	1.165	1.169	1.177	1.184	1.192	1.200	1.207	1.214	1.222	1.229	1.236	1.243	1.250	1.257	1.264	1.271	1.277	1.284	1.290
23		1.431	1.584	1.745	1.828	1.913	2.089	2.272	2.460	2.654	2.854	3.058	3.267	3.480	3.697	3.917	4.141	4.369	4.599	4.832	5.068	5.307	5.547
24		1.413	1.564	1.722	1.804	1.888	2.062	2.242	2.428	2.620	2.817	3.019	3.226	3.437	3.651	3.870	4.091	4.317	4.545	4.777	5.010	5.247	5.481
25		1.396	1.544	1.700	1.781	1.864	2.035	2.213	2.397	2.587	2.782	2.981	3.186	3.394	3.607	3.823	4.043	4.267	4.502	4.722	4.954	5.189	5.426
26		1.380	1.525	1.679	1.759	1.844	2.010	2.186	2.367	2.554	2.747	2.945	3.147	3.353	3.564	3.778	3.996	4.218	4.442	4.670	4.900	5.133	5.368
27		1.364	1.507	1.659	1.738	1.818	1.985	2.159	2.338	2.523	2.714	2.909	3.109	3.308	3.522	3.735	3.950	4.170	4.392	4.618	4.846	5.077	5.311
28		1.348	1.489	1.639	1.717	1.797	1.961	2.132	2.310	2.493	2.681	2.874	3.072	3.275	3.481	3.692	3.906	4.123	4.344	4.568	4.794	5.024	5.255
29		1.333	1.473	1.620	1.697	1.776	1.938	2.107	2.282	2.463	2.650	2.841	3.037	3.237	3.442	3.650	3.862	4.078	4.297	4.518	4.743	4.971	5.201
30		1.319	1.456	1.602	1.678	1.755	1.916	2.083	2.256	2.435	2.619	2.808	3.002	3.201	3.403	3.610	3.820	4.034	4.251	4.471	4.693	4.919	5.148
31		1.305	1.440	1.584	1.659	1.735	1.894	2.059	2.230	2.407	2.589	2.776	2.969	3.165	3.366	3.570	3.778	3.990	4.206	4.424	4.645	4.869	5.098
32		1.291	1.425	1.567	1.641	1.716	1.873	2.036	2.205	2.380	2.560	2.745	2.936	3.130	3.329	3.532	3.738	3.948	4.162	4.378	4.597	4.820	5.045
33		1.279	1.410	1.550	1.623	1.698	1.852	2.013	2.181	2.354	2.532	2.715	2.904	3.096	3.293	3.494	3.699	3.907	4.119	4.333	4.551	4.772	4.995
34		1.266	1.396	1.534	1.606	1.680	1.832	1.992	2.157	2.328	2.505	2.686	2.873	3.063	3.258	3.458	3.660	3.867	4.077	4.290	4.506	4.725	4.947
35		1.254	1.382	1.518	1.589	1.662	1.813	1.970	2.134	2.303	2.478	2.658	2.842	3.031	3.224	3.422	3.623	3.828	4.036	4.247	4.461	4.679	4.899
36		1.242	1.369	1.503	1.573	1.645	1.794	1.950	2.112	2.279	2.452	2.630	2.813	3.000	3.191	3.387	3.586	3.789	3.995	4.205	4.418	4.634	4.852
37		1.231	1.356	1.4																			

TABLE 2.- HAT-PANEL PROPERTIES $\left[\frac{t_W}{t_S} = 0.40; \frac{b_H}{b_W} = 0.8; \frac{b_A}{t_W} = 20.75; \frac{b_H}{t_W} = 0.8 \frac{b_W}{t_W}; \frac{b_R}{t_W} = 0.8 \frac{b_W}{t_W} + 20.25; \frac{r}{t_W} = 3.13; \frac{d}{t_S} = 1.84; \frac{p}{t_S} = 9.80 \right]$ - Concluded

$\frac{b_W}{t_S}$	19	21	23	24	25	27	29	31	33	35	37	39	41	43	45	47	49	51	53	55	57	59
42	1.178	1.296	1.421	1.486	1.553	1.692	1.838	1.989	2.147	2.309	2.477	2.650	2.827	3.008	3.194	3.383	3.577	3.773	3.974	4.177	4.383	4.592
44	1.159	1.274	1.396	1.460	1.526	1.662	1.804	1.953	2.107	2.266	2.431	2.600	2.774	2.953	3.135	3.321	3.512	3.705	3.902	4.103	4.306	4.512
46	1.142	1.254	1.373	1.435	1.499	1.633	1.772	1.918	2.069	2.225	2.387	2.553	2.724	2.899	3.079	3.261	3.450	3.640	3.834	4.032	4.232	4.436
48	1.125	1.234	1.351	1.412	1.475	1.605	1.742	1.884	2.033	2.186	2.345	2.508	2.677	2.848	3.040	3.205	3.390	3.578	3.769	3.963	4.161	4.362
50	1.109	1.216	1.330	1.390	1.451	1.579	1.713	1.854	1.998	2.141	2.294	2.465	2.630	2.802	2.973	3.151	3.333	3.518	3.706	3.898	4.093	4.290
52	1.094	1.198	1.310	1.368	1.428	1.554	1.685	1.822	1.965	2.112	2.266	2.422	2.586	2.799	2.924	3.099	3.277	3.460	3.645	3.834	4.027	4.222
54	1.079	1.181	1.291	1.348	1.417	1.530	1.659	1.793	1.933	2.079	2.229	2.384	2.544	2.708	2.876	3.048	3.224	3.404	3.587	3.773	3.963	4.156
56	1.065	1.165	1.273	1.329	1.387	1.507	1.633	1.765	1.903	2.046	2.194	2.346	2.503	2.665	2.826	3.030	3.173	3.350	3.531	3.714	3.902	4.092
58	1.052	1.150	1.255	1.310	1.367	1.485	1.609	1.739	1.874	2.014	2.160	2.310	2.464	2.623	2.786	2.953	3.124	3.299	3.476	3.658	3.842	4.030
60	1.040	1.136	1.239	1.293	1.348	1.464	1.586	1.713	1.846	1.984	2.127	2.275	2.427	2.583	2.744	2.908	3.077	3.249	3.424	3.603	3.785	3.970
63	1.022	1.115	1.215	1.267	1.322	1.434	1.553	1.677	1.806	1.941	2.080	2.225	2.373	2.526	2.683	2.824	3.009	3.177	3.349	3.524	3.703	3.885
66	1.005	1.086	1.193	1.244	1.297	1.406	1.522	1.643	1.769	1.900	2.036	2.177	2.322	2.472	2.626	2.783	2.945	3.109	3.278	3.450	3.629	3.803
69	.9894	1.078	1.172	1.222	1.273	1.380	1.492	1.610	1.734	1.862	1.995	2.132	2.274	2.421	2.571	2.725	2.883	3.045	3.210	3.378	3.550	3.725
72	.9747	1.060	1.153	1.201	1.251	1.355	1.465	1.580	1.700	1.825	1.955	2.090	2.229	2.372	2.519	2.670	2.825	2.983	3.145	3.311	3.479	3.651
75	.9609	1.044	1.134	1.181	1.230	1.331	1.439	1.551	1.668	1.791	1.918	2.049	2.185	2.326	2.470	2.618	2.770	2.925	3.084	3.246	3.411	3.580
78	.9478	1.029	1.117	1.163	1.210	1.309	1.414	1.523	1.638	1.758	1.882	2.011	2.144	2.283	2.423	2.568	2.717	2.869	3.025	3.184	3.347	3.512
81	.9355	1.015	1.100	1.145	1.191	1.288	1.390	1.497	1.610	1.727	1.848	1.975	2.105	2.239	2.380	2.520	2.666	2.816	2.969	3.125	3.285	3.448
84	.9238	1.001	1.085	1.130	1.174	1.268	1.368	1.473	1.583	1.697	1.816	1.940	2.068	2.199	2.338	2.475	2.618	2.765	2.915	3.069	3.225	3.386
23	2.189	2.480	2.775	2.911	3.078	3.383	3.691	4.003	4.316	4.632	4.950	5.269	5.590	5.910	6.234	6.558	6.882	7.207	7.599	7.880	8.166	8.514
24	2.172	2.461	2.757	2.890	3.056	3.358	3.667	3.978	4.291	4.605	4.922	5.241	5.560	5.881	6.204	6.526	6.851	7.175	7.501	7.827	8.153	8.480
25	2.155	2.443	2.737	2.870	3.035	3.338	3.644	3.953	4.265	4.578	4.894	5.212	5.531	5.852	6.174	6.496	6.819	7.148	7.468	7.794	8.149	8.446
26	2.139	2.425	2.718	2.850	3.014	3.316	3.621	3.929	4.240	4.553	4.868	5.185	5.485	5.823	6.144	6.465	6.786	7.112	7.437	7.761	8.087	8.413
27	2.123	2.408	2.699	2.831	2.994	3.295	3.598	3.905	4.215	4.527	4.837	5.157	5.473	5.794	6.114	6.435	6.757	7.081	7.405	7.729	8.054	8.380
28	2.107	2.391	2.680	2.812	2.975	3.273	3.576	3.882	4.191	4.501	4.815	5.130	5.447	5.765	6.085	6.406	6.727	7.050	7.373	7.697	8.022	8.348
29	2.092	2.374	2.662	2.793	2.955	3.253	3.554	3.859	4.167	4.477	4.791	5.103	5.420	5.737	6.056	6.376	6.697	7.019	7.344	7.666	7.990	8.315
30	2.077	2.356	2.644	2.775	2.936	3.232	3.533	3.836	4.143	4.452	4.764	5.076	5.392	5.709	6.027	6.347	6.667	6.989	7.311	7.635	7.958	8.283
31	2.063	2.341	2.627	2.757	2.917	3.212	3.511	3.814	4.120	4.428	4.738	5.051	5.365	5.682	5.999	6.318	6.638	6.959	7.281	7.604	7.927	8.269
32	2.048	2.326	2.609	2.739	2.899	3.193	3.491	3.792	4.097	4.404	4.714	5.025	5.339	5.655	5.971	6.290	6.609	6.929	7.251	7.573	7.896	8.219
33	2.034	2.310	2.593	2.722	2.881	3.173	3.470	3.771	4.074	4.380	4.689	5.000	5.313	5.628	5.935	6.261	6.580	6.900	7.221	7.542	7.867	8.188
34	2.020	2.295	2.576	2.705	2.863	3.154	3.450	3.749	4.052	4.357	4.665	4.975	5.287	5.601	5.917	6.233	6.550	6.871	7.191	7.512	7.834	8.157
35	2.007	2.280	2.560	2.688	2.845	3.136	3.430	3.728	4.030	4.334	4.641	4.951	5.262	5.575	5.904	6.206	6.523	6.842	7.162	7.482	7.804	8.126
36	1.994	2.265	2.544	2.671	2.827	3.117	3.411	3.708	4.008	4.312	4.618	4.926	5.237	5.549	5.863	6.179	6.495	6.814	7.133	7.453	7.774	8.096
37	1.981	2.251	2.528	2.655	2.811	3.099	3.392	3.688	3.987	4.290	4.595	4.902	5.212	5.524	5.837	6.144	6.467	6.785	7.104	7.423	7.744	8.065
38	1.968	2.237	2.513	2.639	2.795	3.081	3.373	3.668	3.965	4.268	4.572	4.878	5.188	5.498	5.811	6.125	6.440	6.757	7.075	7.394	7.714	8.035
39	1.955	2.223	2.498	2.624	2.778	3.064	3.354	3.648	3.946	4.246	4.550	4.855	5.163	5.473	5.784	6.099	6.426	6.730	7.047	7.366	7.685	8.005
40	1.943	2.210	2.483	2.608	2.762	3.047	3.336	3.629	3.925	4.225	4.527	4.832	5.139	5.450	5.760	6.073	6.387	6.702	7.017	7.337	7.656	7.976
42	1.919	2.183	2.454	2.578	2.731	3.013	3.300	3.591	3.885	4.183	4.484	4.787	5.093	5.400	5.710	6.021	6.334	6.648	6.964	7.281	7.599	7.918
44	1.896	2.158	2.422	2.545	2.701	2.981	3.265	3.554	3.854	4.143	4.440	4.743	5.047	5.353	5.661	5.971	6.283	6.596	6.910	7.226	7.543	7.861
46	1.874	2.133	2.399	2.522	2.671	2.949	3.231	3.518	3.809	4.103	4.400	4.700	5.002	5.307	5.614	5.923	6.232	6.544	6.857	7.153	7.488	7.844
48	1.853	2.109	2.373	2.494	2.643	2.910	3.199	3.484	3.780	4.065	4.360	4.658	4.958	5.262	5.577	5.874	6.183	6.490	6.805	7.119	7.433	7.749
50	1.832	2.086	2.348	2.468	2.615	2.890	3.187	3.450	3.737	4.021	4.321	4.617	4.916	5.217	5.521	5.827	6.135	6.444	6.755	7.067	7.380	7.698
52	1.812	2.064	2.323	2.443	2.589	2.860	3.136	3.417	3.712	3.991	4.281	4.578	4.875	5.159	5.477	5.781	6.087	6.395	6.705	7.016	7.328	7.642
54	1.793	2.042	2.299	2.418	2.561	2.832	3.106	3.385	3.668	3.955	4.245	4.538	4.834	5.133	5.432	5.736	6.041	6.348	6.658	6.966	7.277	7.590
56	1.774	2.021	2.276	2.394	2.538	2.805	3.077	3.354	3.635	3.919	4.208	4.500	4.795	5.092	5.392	5.682	5.996	6.301	6.608	6.917	7.227	7.539
58	1.756	2.001	2.254	2.371	2.514	2.781	3.049	3.324	3.603	3.887	4.173	4.460	4.756	5.051	5.349	5.649	5.948	6.256	6.562	6.869	7.178	7.488
60	1.738	1.981	2.232	2.348	2.489	2.753	3.021	3.294	3.572	3.854	4.139	4.427	4.718	5.012	5.308	5.607	5.908	6.211	6.515	6.822	7.134	7.439
63	1.713	1.953	2.201	2.315	2.455	2.715	2.981	3.252	3.527	3.806	4.088	4.374	4.663	4.955	5.249	5.531	5.844	6.145	6.448	6.752	7.058	7.366
66	1.689	1.926	2.170	2.284	2.425	2.680	2.943	3.211	3.483	3.759	4.040	4.323	4.610	4.899	5.191	5.486	5.783	6.082	6.383	6.685	6.988	7.295
69	1.665	1.900	2.141	2.254	2.390	2.645	2.905	3.171	3.448	3.715	3.993	4.274	4.558	4.845	5.135	5.428	5.723	6.020	6.319	6.620	6.922	7.228
72	1.643	1.874	2.114	2.225	2.360	2.613	2.870	3.133	3.400	3.672	3.947	4.226	4.508	4.793	5.080	5.372	5.665	5.960	6.257	6.556	6.857	7.159
75	1.622	1.850	2.087	2.197	2.330	2.580	2.835	3.096	3.361	3.630	3.905	4.180	4.460	4.743	5.029	5.317	5.608	5.901	6.197	6.494	6.793	7.094
78	1.601	1.8																				

TABLE 3.- HAT-PANEL PROPERTIES $\left[\frac{t_W}{t_S} = 0.51; \frac{b_H}{b_W} = 0.8; \frac{b_A}{t_W} = 19.56; \frac{b_H}{t_W} = 0.8 \frac{b_W}{t_W}; \frac{b_R}{t_W} = 0.8 \frac{b_W}{t_W} + 19.06; \frac{r}{t_W} = 3.13; \frac{d}{t_S} = 2.14; \frac{p}{t_S} = 10.92 \right]$

$\frac{b_W}{t_W}$	19	21	23	24	25	27	29	31	33	35	37	39	41	43	45	47	49	51	53	55	57	59
23	1.559	1.583	1.607	1.619	1.630	1.652	1.673	1.694	1.713	1.732	1.751	1.769	1.786	1.802	1.818	1.834	1.849	1.864	1.878	1.892	1.905	1.918
24	1.545	1.569	1.593	1.604	1.615	1.637	1.658	1.678	1.698	1.717	1.735	1.753	1.770	1.787	1.803	1.818	1.833	1.848	1.862	1.876	1.889	1.902
25	1.532	1.556	1.579	1.590	1.602	1.623	1.644	1.664	1.683	1.702	1.720	1.738	1.755	1.771	1.787	1.803	1.818	1.832	1.847	1.860	1.874	1.887
26	1.520	1.543	1.566	1.577	1.588	1.610	1.630	1.655	1.669	1.688	1.706	1.723	1.740	1.757	1.773	1.788	1.803	1.817	1.832	1.845	1.859	1.872
27	1.508	1.531	1.554	1.565	1.576	1.597	1.617	1.637	1.656	1.674	1.692	1.709	1.726	1.751	1.758	1.774	1.789	1.803	1.817	1.831	1.844	1.857
28	1.496	1.520	1.542	1.553	1.563	1.584	1.604	1.624	1.643	1.661	1.679	1.696	1.713	1.729	1.745	1.760	1.775	1.789	1.803	1.817	1.830	1.843
29	1.486	1.508	1.530	1.541	1.552	1.572	1.592	1.612	1.630	1.648	1.666	1.683	1.700	1.716	1.731	1.747	1.761	1.776	1.790	1.803	1.817	1.830
30	1.475	1.498	1.520	1.530	1.541	1.561	1.581	1.600	1.618	1.636	1.654	1.671	1.687	1.703	1.719	1.734	1.749	1.763	1.777	1.790	1.804	1.816
31	1.465	1.488	1.509	1.520	1.530	1.550	1.570	1.588	1.607	1.625	1.642	1.659	1.675	1.691	1.706	1.721	1.736	1.750	1.764	1.778	1.791	1.804
32	1.456	1.478	1.499	1.509	1.520	1.540	1.559	1.576	1.596	1.613	1.631	1.647	1.663	1.679	1.695	1.709	1.724	1.738	1.752	1.765	1.779	1.791
33	1.447	1.468	1.489	1.500	1.510	1.529	1.548	1.567	1.585	1.602	1.620	1.636	1.652	1.668	1.683	1.698	1.712	1.726	1.740	1.754	1.767	1.779
34	1.438	1.459	1.480	1.490	1.500	1.520	1.539	1.557	1.575	1.592	1.609	1.625	1.641	1.657	1.672	1.687	1.701	1.715	1.729	1.742	1.755	1.768
35	1.430	1.451	1.471	1.482	1.491	1.510	1.529	1.547	1.565	1.582	1.599	1.615	1.631	1.646	1.661	1.676	1.690	1.704	1.718	1.731	1.744	1.756
36	1.422	1.442	1.462	1.472	1.482	1.501	1.520	1.538	1.555	1.572	1.589	1.605	1.621	1.638	1.651	1.665	1.679	1.693	1.707	1.720	1.733	1.745
37	1.414	1.434	1.454	1.464	1.474	1.492	1.511	1.528	1.546	1.563	1.579	1.595	1.611	1.628	1.641	1.655	1.669	1.683	1.696	1.710	1.722	1.735
38	1.406	1.426	1.446	1.456	1.465	1.484	1.502	1.520	1.537	1.553	1.570	1.586	1.601	1.616	1.631	1.645	1.659	1.673	1.686	1.699	1.712	1.724
39	1.399	1.419	1.438	1.448	1.457	1.476	1.494	1.511	1.528	1.545	1.561	1.578	1.592	1.606	1.621	1.636	1.650	1.663	1.676	1.689	1.702	1.714
40	1.392	1.412	1.431	1.440	1.450	1.468	1.486	1.503	1.520	1.536	1.552	1.568	1.583	1.598	1.612	1.626	1.640	1.654	1.667	1.679	1.692	1.705
42	1.379	1.398	1.417	1.426	1.435	1.453	1.470	1.487	1.504	1.520	1.535	1.551	1.568	1.580	1.595	1.608	1.622	1.635	1.648	1.661	1.674	1.688
44	1.366	1.385	1.403	1.412	1.421	1.439	1.456	1.472	1.488	1.504	1.520	1.535	1.549	1.564	1.578	1.592	1.605	1.618	1.631	1.644	1.656	1.668
46	1.355	1.373	1.391	1.400	1.408	1.425	1.442	1.458	1.474	1.490	1.505	1.520	1.534	1.548	1.562	1.576	1.589	1.602	1.615	1.627	1.639	1.651
48	1.344	1.362	1.379	1.388	1.396	1.413	1.429	1.445	1.461	1.476	1.491	1.505	1.520	1.533	1.547	1.561	1.574	1.586	1.599	1.611	1.623	1.635
50	1.333	1.351	1.368	1.377	1.385	1.401	1.417	1.433	1.448	1.463	1.478	1.492	1.506	1.520	1.533	1.546	1.559	1.572	1.584	1.596	1.608	1.620
52	1.324	1.341	1.358	1.366	1.374	1.390	1.406	1.421	1.436	1.451	1.465	1.479	1.493	1.506	1.520	1.533	1.545	1.558	1.570	1.582	1.594	1.605
54	1.315	1.331	1.348	1.356	1.364	1.380	1.395	1.412	1.425	1.439	1.453	1.467	1.481	1.494	1.507	1.520	1.532	1.544	1.557	1.568	1.580	1.591
56	1.306	1.322	1.339	1.346	1.354	1.370	1.385	1.399	1.414	1.428	1.442	1.455	1.469	1.482	1.495	1.507	1.520	1.532	1.544	1.555	1.567	1.578
58	1.298	1.314	1.330	1.337	1.345	1.360	1.375	1.389	1.404	1.417	1.431	1.445	1.458	1.471	1.483	1.496	1.508	1.520	1.531	1.543	1.554	1.565
60	1.290	1.306	1.321	1.329	1.336	1.351	1.366	1.380	1.394	1.408	1.421	1.434	1.447	1.460	1.472	1.484	1.496	1.508	1.520	1.531	1.542	1.553
63	1.279	1.295	1.310	1.317	1.324	1.339	1.353	1.368	1.380	1.393	1.406	1.419	1.432	1.444	1.457	1.468	1.480	1.492	1.503	1.514	1.525	1.536
66	1.269	1.284	1.299	1.306	1.313	1.327	1.340	1.354	1.367	1.380	1.393	1.405	1.418	1.430	1.442	1.454	1.465	1.476	1.487	1.498	1.509	1.520
69	1.260	1.274	1.288	1.295	1.302	1.316	1.329	1.342	1.355	1.368	1.380	1.393	1.405	1.416	1.428	1.440	1.451	1.462	1.473	1.483	1.494	1.504
72	1.251	1.265	1.279	1.286	1.292	1.306	1.319	1.331	1.344	1.356	1.368	1.380	1.392	1.404	1.415	1.426	1.437	1.448	1.459	1.469	1.480	1.490
75	1.243	1.257	1.270	1.276	1.283	1.296	1.309	1.321	1.333	1.345	1.357	1.369	1.380	1.392	1.403	1.414	1.425	1.435	1.446	1.456	1.466	1.476
78	1.235	1.248	1.261	1.268	1.274	1.287	1.299	1.311	1.323	1.335	1.347	1.358	1.370	1.381	1.392	1.402	1.413	1.423	1.434	1.444	1.454	1.464
81	1.228	1.241	1.254	1.260	1.266	1.278	1.290	1.302	1.313	1.326	1.337	1.348	1.359	1.370	1.381	1.391	1.402	1.412	1.422	1.432	1.442	1.451
84	1.221	1.234	1.246	1.252	1.258	1.270	1.282	1.294	1.305	1.316	1.328	1.339	1.349	1.360	1.370	1.381	1.391	1.401	1.411	1.421	1.430	1.440
23	2.019	2.265	2.523	2.656	2.792	3.070	3.368	3.653	3.956	4.265	4.581	4.903	5.229	5.561	5.897	6.237	6.581	6.928	7.280	7.634	7.991	8.351
24	1.995	2.238	2.494	2.625	2.759	3.035	3.320	3.612	3.912	4.213	4.533	4.851	5.176	5.505	5.839	6.176	6.518	6.864	7.212	7.565	7.920	8.279
25	1.972	2.212	2.465	2.595	2.728	3.000	3.282	3.572	3.870	4.163	4.485	4.801	5.123	5.450	5.782	6.117	6.457	6.800	7.146	7.498	7.851	8.207
26	1.950	2.187	2.438	2.565	2.697	2.967	3.246	3.533	3.828	4.112	4.438	4.752	5.072	5.397	5.726	6.059	6.397	6.738	7.082	7.432	7.783	8.138
27	1.930	2.162	2.409	2.537	2.667	2.934	3.211	3.495	3.788	4.063	4.393	4.705	5.022	5.344	5.671	6.002	6.338	6.677	7.019	7.367	7.716	8.069
28	1.907	2.139	2.383	2.509	2.637	2.902	3.176	3.458	3.748	4.016	4.349	4.658	4.973	5.293	5.618	5.947	6.281	6.618	6.958	7.304	7.651	8.002
29	1.886	2.115	2.357	2.481	2.609	2.871	3.142	3.422	3.709	3.969	4.305	4.612	4.925	5.243	5.565	5.892	6.224	6.559	6.897	7.241	7.587	7.936
30	1.866	2.093	2.332	2.455	2.581	2.841	3.110	3.387	3.672	3.924	4.263	4.567	4.878	5.193	5.514	5.839	6.168	6.502	6.838	7.180	7.524	7.871
31	1.847	2.071	2.307	2.429	2.554	2.811	3.078	3.352	3.635	3.880	4.221	4.524	4.832	5.145	5.464	5.787	6.114	6.445	6.780	7.120	7.462	7.807
32	1.828	2.050	2.283	2.404	2.529	2.783	3.047	3.319	3.600	3.836	4.181	4.481	4.787	5.098	5.414	5.735	6.061	6.390	6.722	7.061	7.401	7.744
33	1.809	2.029																				

TABLE 3.- HAT-PANEL PROPERTIES $\left[\frac{t_W}{t_S} = 0.51; \frac{b_H}{b_W} = 0.8; \frac{b_A}{t_W} = 19.56; \frac{b_H}{t_W} = 0.8 \frac{b_W}{t_W}; \frac{b_R}{t_W} = 0.8 \frac{b_W}{t_W} + 19.06; \frac{r}{t_W} = 3.13; \frac{d}{t_S} = 2.14; \frac{p}{t_S} = 10.92 \right]$ - Concluded

Table with columns for b_W/t_W, b_S/t_S, and rows for h/t_S and p/t_S. The table contains numerical data for various parameter values (19, 21, 23, 24, 25, 27, 29, 31, 33, 35, 37, 39, 41, 43, 45, 47, 49, 51, 53, 55, 57, 59).



TABLE 4.- HAT-PANEL PROPERTIES $\left[\frac{t_W}{t_S} = 0.63; \frac{b_H}{b_W} = 0.8; \frac{b_A}{t_W} = 18.25; \frac{b_H}{t_W} = 0.8 \frac{b_W}{t_W}; \frac{b_R}{t_W} = 0.8 \frac{b_W}{t_W} + 17.75; \frac{r}{t_W} = 3.13; \frac{d}{t_S} = 2.44; \frac{p}{t_S} = 11.72 \right]$

$\frac{b_W}{t_S} \backslash \frac{b_W}{t_W}$	19	21	23	24	25	27	29	31	33	35	37	39	41	43	45	47	49	51	53	55	57	59
23	1.760	1.793	1.825	1.840	1.855	1.894	1.911	1.938	1.963	1.988	2.011	2.034	2.056	2.077	2.097	2.117	2.136	2.154	2.172	2.189	2.206	2.221
24	1.743	1.775	1.807	1.822	1.837	1.865	1.893	1.919	1.944	1.969	1.992	2.015	2.037	2.058	2.078	2.097	2.117	2.135	2.153	2.170	2.186	2.202
25	1.727	1.759	1.790	1.805	1.820	1.848	1.878	1.901	1.926	1.951	1.974	1.997	2.018	2.039	2.060	2.079	2.098	2.116	2.134	2.151	2.168	2.184
26	1.711	1.743	1.774	1.788	1.803	1.831	1.858	1.884	1.909	1.933	1.956	1.979	2.001	2.021	2.042	2.061	2.080	2.098	2.116	2.133	2.150	2.166
27	1.696	1.728	1.758	1.773	1.787	1.815	1.842	1.868	1.892	1.916	1.940	1.962	1.984	2.004	2.025	2.044	2.063	2.081	2.099	2.116	2.133	2.149
28	1.682	1.713	1.743	1.758	1.772	1.799	1.826	1.852	1.876	1.902	1.923	1.946	1.967	1.988	2.008	2.027	2.046	2.064	2.082	2.099	2.116	2.132
29	1.668	1.699	1.729	1.743	1.757	1.784	1.811	1.836	1.861	1.885	1.908	1.930	1.951	1.972	1.992	2.011	2.030	2.048	2.066	2.083	2.100	2.116
30	1.655	1.685	1.715	1.729	1.743	1.770	1.795	1.821	1.846	1.870	1.892	1.914	1.936	1.956	1.976	1.995	2.013	2.032	2.050	2.067	2.084	2.099
31	1.642	1.672	1.701	1.715	1.729	1.756	1.782	1.807	1.831	1.855	1.878	1.899	1.921	1.941	1.961	1.980	1.999	2.017	2.035	2.052	2.068	2.085
32	1.630	1.660	1.688	1.702	1.716	1.743	1.768	1.793	1.818	1.841	1.863	1.885	1.906	1.926	1.946	1.965	1.984	2.002	2.020	2.037	2.053	2.070
33	1.618	1.648	1.676	1.690	1.703	1.730	1.755	1.780	1.804	1.827	1.849	1.871	1.892	1.912	1.932	1.951	1.970	1.988	2.006	2.022	2.039	2.055
34	1.607	1.636	1.664	1.678	1.691	1.717	1.743	1.767	1.791	1.815	1.838	1.857	1.878	1.899	1.918	1.937	1.956	1.974	1.991	2.008	2.025	2.041
35	1.598	1.625	1.653	1.666	1.679	1.705	1.730	1.755	1.778	1.801	1.823	1.844	1.865	1.885	1.905	1.924	1.942	1.960	1.977	1.994	2.011	2.027
36	1.585	1.614	1.641	1.655	1.668	1.694	1.719	1.743	1.766	1.789	1.810	1.832	1.852	1.872	1.892	1.911	1.929	1.947	1.964	1.981	1.998	2.014
37	1.575	1.603	1.631	1.644	1.657	1.682	1.707	1.731	1.754	1.776	1.798	1.819	1.840	1.860	1.879	1.898	1.916	1.934	1.951	1.968	1.984	2.001
38	1.565	1.593	1.620	1.633	1.646	1.672	1.696	1.720	1.743	1.765	1.786	1.807	1.828	1.848	1.867	1.885	1.904	1.921	1.939	1.955	1.972	1.988
39	1.556	1.583	1.610	1.623	1.636	1.661	1.685	1.709	1.731	1.753	1.775	1.796	1.816	1.836	1.855	1.873	1.892	1.909	1.926	1.943	1.959	1.975
40	1.547	1.574	1.600	1.613	1.626	1.651	1.675	1.698	1.721	1.742	1.764	1.784	1.805	1.824	1.843	1.862	1.880	1.897	1.914	1.931	1.947	1.963
42	1.529	1.556	1.582	1.594	1.607	1.631	1.655	1.678	1.700	1.721	1.742	1.763	1.783	1.802	1.821	1.839	1.857	1.874	1.891	1.908	1.924	1.940
44	1.513	1.539	1.564	1.576	1.589	1.613	1.636	1.658	1.680	1.701	1.722	1.742	1.762	1.781	1.800	1.818	1.835	1.853	1.870	1.886	1.902	1.918
46	1.497	1.523	1.548	1.560	1.572	1.595	1.618	1.640	1.662	1.683	1.703	1.723	1.742	1.761	1.780	1.797	1.815	1.832	1.858	1.865	1.881	1.896
48	1.483	1.508	1.532	1.548	1.556	1.579	1.601	1.623	1.644	1.665	1.685	1.704	1.724	1.742	1.760	1.778	1.795	1.812	1.829	1.845	1.861	1.876
50	1.469	1.494	1.517	1.529	1.541	1.563	1.585	1.607	1.628	1.648	1.668	1.687	1.706	1.724	1.742	1.760	1.777	1.794	1.810	1.826	1.842	1.857
52	1.456	1.480	1.504	1.515	1.526	1.549	1.570	1.591	1.612	1.632	1.651	1.670	1.689	1.707	1.725	1.742	1.759	1.776	1.792	1.808	1.823	1.838
54	1.444	1.467	1.490	1.502	1.513	1.535	1.556	1.577	1.597	1.616	1.636	1.654	1.673	1.691	1.708	1.725	1.742	1.758	1.775	1.790	1.806	1.821
56	1.432	1.455	1.478	1.489	1.500	1.521	1.542	1.563	1.582	1.602	1.621	1.639	1.657	1.675	1.692	1.709	1.726	1.742	1.758	1.773	1.789	1.804
58	1.421	1.444	1.466	1.477	1.488	1.509	1.530	1.549	1.569	1.588	1.607	1.625	1.643	1.660	1.677	1.694	1.710	1.726	1.742	1.757	1.772	1.787
60	1.411	1.433	1.455	1.465	1.476	1.497	1.517	1.537	1.556	1.575	1.593	1.611	1.629	1.646	1.663	1.679	1.695	1.711	1.727	1.742	1.757	1.772
63	1.398	1.418	1.439	1.449	1.459	1.480	1.499	1.519	1.537	1.556	1.574	1.591	1.609	1.626	1.642	1.658	1.674	1.690	1.705	1.720	1.735	1.749
66	1.382	1.403	1.424	1.434	1.444	1.464	1.483	1.502	1.520	1.538	1.556	1.573	1.590	1.607	1.623	1.639	1.654	1.670	1.685	1.699	1.714	1.728
69	1.369	1.390	1.410	1.420	1.430	1.449	1.468	1.486	1.504	1.522	1.539	1.556	1.572	1.589	1.605	1.620	1.636	1.651	1.665	1.680	1.694	1.708
72	1.357	1.377	1.397	1.407	1.416	1.435	1.453	1.471	1.489	1.506	1.523	1.539	1.556	1.572	1.587	1.603	1.618	1.633	1.647	1.661	1.675	1.689
75	1.346	1.366	1.385	1.394	1.403	1.422	1.440	1.457	1.474	1.491	1.508	1.524	1.540	1.556	1.571	1.586	1.610	1.616	1.630	1.644	1.658	1.671
78	1.336	1.355	1.373	1.382	1.392	1.409	1.427	1.444	1.461	1.477	1.494	1.510	1.525	1.541	1.556	1.571	1.585	1.599	1.614	1.627	1.641	1.654
81	1.326	1.344	1.362	1.371	1.380	1.398	1.415	1.432	1.448	1.464	1.480	1.496	1.511	1.526	1.541	1.556	1.570	1.584	1.598	1.612	1.625	1.638
84	1.316	1.335	1.352	1.361	1.370	1.387	1.404	1.420	1.436	1.452	1.468	1.483	1.498	1.513	1.527	1.542	1.556	1.570	1.583	1.597	1.610	1.623
23	2.770	3.131	3.509	3.698	3.899	4.302	4.716	5.139	5.571	6.011	6.458	6.913	7.372	7.838	8.309	8.784	9.264	9.746	10.23	10.73	11.22	11.72
24	2.740	3.096	3.473	3.660	3.861	4.260	4.670	5.091	5.520	5.958	6.402	6.854	7.311	7.775	8.243	8.716	9.194	9.675	10.16	10.65	11.14	11.64
25	2.712	3.067	3.438	3.624	3.823	4.219	4.636	5.044	5.471	5.906	6.348	6.797	7.252	7.713	8.179	8.650	9.125	9.604	10.09	10.58	11.07	11.56
26	2.684	3.036	3.403	3.588	3.785	4.179	4.584	4.998	5.422	5.854	6.294	6.741	7.193	7.652	8.116	8.584	9.058	9.535	10.02	10.50	10.99	11.48
27	2.657	3.006	3.370	3.553	3.749	4.139	4.541	4.953	5.374	5.804	6.241	6.685	7.135	7.592	8.053	8.520	8.991	9.466	9.946	10.43	10.92	11.41
28	2.630	2.976	3.338	3.519	3.713	4.101	4.500	4.909	5.327	5.750	6.189	6.631	7.079	7.533	7.992	8.457	8.926	9.399	9.877	10.36	10.84	11.33
29	2.605	2.947	3.306	3.486	3.678	4.063	4.459	4.866	5.281	5.706	6.138	6.577	7.023	7.474	7.932	8.394	8.861	9.333	9.809	10.29	10.77	11.26
30	2.578	2.919	3.275	3.453	3.644	4.026	4.415	4.824	5.236	5.658	6.088	6.525	6.968	7.418	7.873	8.333	8.791	9.257	9.741	10.22	10.70	11.18
31	2.555	2.892	3.244	3.421	3.611	3.990	4.381	4.782	5.192	5.612	6.039	6.473	6.914	7.361	7.815	8.272	8.736	9.203	9.675	10.15	10.63	11.11
32	2.531	2.865	3.214	3.390	3.578	3.954	4.342	4.741	5.149	5.565	5.990	6.422	6.861	7.306	7.757	8.213	8.674	9.139	9.610	10.08	10.56	11.04
33	2.507	2.838	3.185	3.359	3.546	3.920	4.305	4.701	5.106	5.521	5.943	6.373	6.809	7.252	7.701	8.154	8.614	9.077	9.546	10.02	10.49	10.97
34	2.485	2.813	3.156	3.330	3.515	3.886	4.268	4.661	5.064	5.472	5.896	6.324	6.758	7.198	7.645	8.097	8.554	9.015	9.482	9.955	10.43	10.90
35	2.462	2.787	3.128	3.300	3.484	3.852	4.232	4.623	5.023	5.433	5.850	6.275	6.707	7.146	7.590	8.040	8.495	8.955	9.419	9.887	10.36	10.84
36	2.440	2.763	3.101	3.272	3.454	3.819	4.197	4.586	4.983	5.390	5.805	6.228	6.658	7.094	7.536	7.984	8.437	8.895	9.358	9.824	10.29	10.77
37	2.419	2.739	3.074	3.243	3.425	3.787	4.162	4.548	4.943	5.348	5.760	6.181	6.609	7.043	7.483	7.929	8.380	8.835	9.296	9.761	10.23	10.70
38																						

TABLE 4.- HAT PANEL PROPERTIES $\left[\frac{t_W}{t_S} = 0.63; \frac{b_H}{b_W} = 0.8; \frac{b_A}{t_W} = 18.25; \frac{b_H}{t_W} = 0.8 \frac{b_W}{t_W}; \frac{b_R}{t_W} = 0.8 \frac{b_W}{t_W} + 17.75; \frac{r}{t_W} = 3.13; \frac{d}{t_S} = 2.44; \frac{p}{t_S} = 11.72 \right]$ - Concluded

$\frac{b_W}{t_W}$	$\frac{b_S}{t_S}$	$\frac{h}{t_S}$																					
		19	21	23	24	25	27	29	31	33	35	37	39	41	43	45	47	49	51	53	55	57	59
42		2.318	2.625	2.948	3.111	3.288	3.636	3.998	4.372	4.755	5.148	5.549	5.959	6.375	6.799	7.229	7.664	8.106	8.552	9.004	9.459	9.919	10.38
44		2.281	2.583	2.901	3.060	3.234	3.579	3.936	4.306	4.684	5.072	5.469	5.875	6.287	6.706	7.132	7.564	8.001	8.444	8.892	9.344	9.801	10.26
46		2.245	2.542	2.856	3.014	3.184	3.524	3.877	4.241	4.616	5.000	5.392	5.793	6.201	6.617	7.039	7.466	7.900	8.339	8.783	9.232	9.685	10.14
48		2.211	2.503	2.812	2.968	3.136	3.471	3.820	4.179	4.549	4.929	5.317	5.714	6.118	6.529	6.948	7.371	7.801	8.237	8.677	9.122	9.572	10.03
50		2.178	2.466	2.770	2.924	3.089	3.420	3.764	4.119	4.485	4.860	5.244	5.637	6.037	6.445	6.859	7.279	7.705	8.137	8.574	9.015	9.462	9.912
52		2.146	2.430	2.729	2.881	3.044	3.371	3.710	4.062	4.423	4.794	5.174	5.562	5.958	6.362	6.772	7.189	7.611	8.039	8.473	8.911	9.354	9.802
54		2.115	2.395	2.690	2.840	3.000	3.323	3.658	4.005	4.362	4.730	5.105	5.490	5.882	6.282	6.689	7.101	7.520	7.945	8.400	8.810	9.250	9.694
56		2.086	2.361	2.652	2.800	2.948	3.277	3.608	3.951	4.304	4.667	5.039	5.420	5.803	6.204	6.607	7.016	7.431	7.852	8.279	8.711	9.147	9.588
58		2.057	2.329	2.616	2.762	2.918	3.232	3.558	3.898	4.247	4.606	4.974	5.351	5.736	6.128	6.527	6.933	7.345	7.762	8.186	8.614	9.048	9.485
60		2.030	2.298	2.581	2.724	2.879	3.189	3.512	3.847	4.192	4.547	4.912	5.285	5.665	6.054	6.450	6.852	7.260	7.674	8.094	8.519	8.949	9.384
63		1.991	2.252	2.530	2.671	2.822	3.127	3.444	3.773	4.113	4.462	4.821	5.188	5.564	5.947	6.337	6.734	7.137	7.546	7.961	8.381	8.807	9.236
66		1.953	2.210	2.482	2.620	2.768	3.067	3.379	3.702	4.036	4.380	4.733	5.095	5.465	5.843	6.228	6.621	7.018	7.422	7.833	8.248	8.669	9.094
69		1.918	2.169	2.435	2.571	2.717	3.010	3.317	3.635	3.963	4.302	4.642	5.006	5.371	5.744	6.124	6.510	6.904	7.303	7.709	8.119	8.535	8.956
72		1.884	2.130	2.391	2.525	2.667	2.956	3.257	3.570	3.893	4.226	4.569	4.921	5.280	5.648	6.023	6.405	6.793	7.188	7.588	7.995	8.406	8.822
75		1.851	2.093	2.349	2.480	2.620	2.904	3.200	3.507	3.826	4.154	4.492	4.838	5.193	5.556	5.926	6.303	6.687	7.077	7.473	7.874	8.281	8.693
78		1.821	2.057	2.309	2.438	2.575	2.854	3.119	3.448	3.781	4.084	4.417	4.759	5.109	5.467	5.832	6.204	6.584	6.969	7.361	7.758	8.160	8.568
81		1.791	2.024	2.271	2.397	2.532	2.806	3.092	3.390	3.698	4.017	4.345	4.683	5.027	5.380	5.741	6.109	6.484	6.864	7.252	7.644	8.043	8.446
84		1.763	1.991	2.234	2.358	2.491	2.760	3.042	3.335	3.639	3.953	4.276	4.608	4.949	5.297	5.654	6.017	6.387	6.763	7.147	7.535	7.929	8.328
23		4.057	4.578	5.102	5.368	5.630	6.160	6.701	7.225	7.766	8.291	8.828	9.360	9.894	10.43	10.96	11.49	12.03	12.56	13.09	13.62	14.16	14.69
24		4.039	4.577	5.082	5.348	5.609	6.139	6.679	7.202	7.744	8.269	8.803	9.337	9.872	10.41	10.94	11.47	12.01	12.54	13.11	13.60	14.13	14.67
25		4.021	4.540	5.063	5.323	5.589	6.118	6.661	7.180	7.721	8.246	8.780	9.314	9.848	10.39	10.92	11.45	11.98	12.52	13.06	13.58	14.11	14.64
26		4.003	4.521	5.043	5.306	5.568	6.097	6.636	7.159	7.698	8.224	8.758	9.291	9.825	10.36	10.89	11.43	11.96	12.49	13.06	13.56	14.09	14.62
27		3.986	4.502	5.024	5.288	5.548	6.076	6.615	7.137	7.677	8.201	8.735	9.268	9.802	10.34	10.87	11.40	11.94	12.47	13.04	13.54	14.07	14.60
28		3.968	4.484	5.006	5.268	5.528	6.056	6.593	7.115	7.655	8.177	8.713	9.245	9.779	10.31	10.85	11.38	11.91	12.45	13.02	13.51	14.04	14.58
29		3.951	4.465	4.985	5.249	5.508	6.035	6.572	7.093	7.633	8.157	8.689	9.223	9.757	10.29	10.82	11.36	11.89	12.42	12.99	13.49	14.02	14.56
30		3.936	4.448	4.967	5.229	5.488	6.015	6.549	7.072	7.611	8.135	8.667	9.193	9.734	10.27	10.80	11.33	11.87	12.40	12.97	13.47	14.00	14.53
31		3.918	4.430	4.948	5.210	5.469	5.994	6.530	7.060	7.609	8.112	8.645	9.177	9.711	10.24	10.78	11.31	11.84	12.38	12.95	13.44	13.98	14.51
32		3.900	4.412	4.929	5.191	5.449	5.974	6.509	7.029	7.567	8.090	8.623	9.155	9.688	10.22	10.76	11.29	11.82	12.36	12.92	13.42	13.95	14.49
33		3.885	4.395	4.910	5.172	5.430	5.954	6.489	7.008	7.545	8.069	8.600	9.133	9.665	10.20	10.73	11.27	11.80	12.33	12.90	13.40	13.93	14.46
34		3.868	4.377	4.892	5.153	5.411	5.934	6.468	6.987	7.524	8.045	8.578	9.110	9.643	10.17	10.71	11.24	11.78	12.31	12.88	13.38	13.91	14.44
35		3.852	4.360	4.874	5.134	5.392	5.914	6.447	6.966	7.502	8.025	8.556	9.088	9.620	10.15	10.69	11.22	11.75	12.29	12.85	13.35	13.89	14.42
36		3.836	4.357	4.856	5.116	5.373	5.895	6.427	6.945	7.481	8.003	8.534	9.065	9.597	10.13	10.67	11.20	11.73	12.26	12.83	13.33	13.86	14.40
37		3.821	4.328	4.838	5.098	5.354	5.875	6.407	6.924	7.460	7.981	8.512	9.043	9.575	10.11	10.64	11.17	11.71	12.24	12.81	13.31	13.84	14.37
38		3.805	4.310	4.820	5.079	5.335	5.856	6.388	6.904	7.438	7.960	8.490	9.020	9.553	10.09	10.62	11.15	11.68	12.22	12.78	13.28	13.82	14.35
39		3.791	4.293	4.803	5.061	5.317	5.836	6.368	6.883	7.417	7.938	8.468	8.998	9.530	10.06	10.60	11.13	11.66	12.19	12.76	13.26	13.79	14.33
40		3.774	4.277	4.785	5.043	5.299	5.817	6.347	6.863	7.396	7.917	8.445	8.977	9.508	10.04	10.57	11.11	11.64	12.17	12.74	13.24	13.77	14.30
42		3.744	4.244	4.751	5.008	5.263	5.779	6.308	6.822	7.355	7.874	8.403	8.933	9.464	9.995	10.53	11.06	11.59	12.13	12.69	13.19	13.72	14.26
44		3.715	4.213	4.717	4.967	5.222	5.742	6.269	6.782	7.314	7.832	8.360	8.889	9.419	9.950	10.48	11.01	11.55	12.08	12.64	13.14	13.68	14.21
46		3.686	4.182	4.684	4.939	5.192	5.704	6.230	6.743	7.273	7.791	8.318	8.846	9.375	9.905	10.44	10.97	11.50	12.03	12.60	13.10	13.67	14.16
48		3.658	4.151	4.652	4.906	5.158	5.670	6.193	6.704	7.233	7.750	8.278	8.703	9.332	9.861	10.39	10.92	11.46	11.99	12.55	13.05	13.59	14.08
50		3.630	4.121	4.619	4.873	5.124	5.634	6.156	6.666	7.193	7.709	8.234	8.761	9.289	9.817	10.35	10.88	11.41	11.94	12.51	13.01	13.54	14.07
52		3.603	4.092	4.588	4.840	5.090	5.599	6.119	6.627	7.154	7.669	8.193	8.718	9.246	9.774	10.30	10.83	11.36	11.90	12.46	12.96	13.49	14.03
54		3.577	4.063	4.557	4.808	5.058	5.564	6.083	6.590	7.115	7.629	8.152	8.677	9.203	9.731	10.26	10.79	11.32	11.85	12.40	12.91	13.45	13.98
56		3.551	4.035	4.527	4.777	5.030	5.531	6.047	6.554	7.077	7.590	8.112	8.636	9.161	9.688	10.22	10.75	11.28	11.81	12.37	12.87	13.40	13.93
58		3.525	4.007	4.497	4.746	4.994	5.497	6.011	6.517	7.039	7.551	8.072	8.595	9.119	9.645	10.17	10.70	11.23	11.76	12.32	12.83	13.35	13.89
60		3.500	3.980	4.468	4.716	4.963	5.464	5.978	6.481	7.002	7.513	8.032	8.554	9.076	9.603	10.13	10.66	11.19	11.72	12.28	12.78	13.31	13.84
63		3.464	3.940	4.425	4.671	4.917	5.416	5.927	6.428	6.947	7.456	7.974	8.494	9.017	9.540	10.07	10.59	11.12	11.65	12.21	12.71	13.24	13.77
66		3.428	3.901	4.383	4.628	4.872	5.369	5.877	6.376	6.893	7.400	7.916	8.435	8.956	9.479	10.00	10.53	11.06	11.59	12.14	12.64	13.17	13.71
69		3.394	3.863	4.342	4.586	4.829	5.322	5.829	6.325	6.840	7.345	7.863	8.377	8.897	9.418	9.942	10.47	10.99	11.52	12.08	12.58	13.11	13.64
72		3.360	3.827	4.302	4.545	4.786	5.277	5.781	6.276	6.788	7.291	7.804	8.320	8.838	9.358	9.880	10.40	10.93	11.46	12.01	12.51	13.04	13.57
75		3.328																					

TABLE 5.- HAT-PANEL PROPERTIES $\left[\frac{t_W}{t_S} = 0.79; \frac{b_H}{b_W} = 0.8; \frac{b_A}{t_W} = 17.17; \frac{b_H}{t_W} = 0.8 \frac{b_W}{t_W}; \frac{b_R}{t_W} = 0.8 \frac{b_W}{t_W} + 16.67; \frac{r}{t_W} = 3.13; \frac{d}{t_S} = 2.82; \frac{p}{t_S} = 12.30 \right]$

$\frac{b_S}{t_S} \backslash \frac{b_W}{t_W}$																						
	19	21	23	24	25	27	29	31	33	35	37	39	41	43	45	47	49	51	53	55	57	59
23	2.061	2.105	2.147	2.168	2.187	2.225	2.262	2.296	2.329	2.361	2.391	2.420	2.448	2.475	2.501	2.525	2.549	2.572	2.594	2.615	2.636	2.656
24	2.039	2.083	2.125	2.145	2.165	2.203	2.239	2.273	2.306	2.338	2.368	2.397	2.425	2.452	2.477	2.502	2.526	2.549	2.571	2.592	2.613	2.633
25	2.019	2.062	2.103	2.123	2.143	2.181	2.217	2.251	2.284	2.315	2.346	2.375	2.403	2.429	2.455	2.480	2.504	2.527	2.549	2.570	2.591	2.611
26	1.998	2.042	2.083	2.102	2.122	2.159	2.195	2.230	2.262	2.294	2.324	2.353	2.381	2.407	2.433	2.458	2.482	2.505	2.528	2.549	2.570	2.590
27	1.979	2.022	2.063	2.082	2.102	2.139	2.175	2.209	2.241	2.273	2.303	2.332	2.360	2.386	2.412	2.437	2.461	2.484	2.507	2.528	2.549	2.569
28	1.961	2.003	2.043	2.063	2.082	2.119	2.155	2.189	2.221	2.252	2.283	2.311	2.339	2.366	2.392	2.417	2.441	2.464	2.486	2.508	2.529	2.549
29	1.943	1.985	2.025	2.044	2.063	2.100	2.136	2.169	2.193	2.233	2.263	2.292	2.319	2.346	2.372	2.397	2.421	2.444	2.466	2.488	2.509	2.529
30	1.925	1.967	2.007	2.026	2.045	2.082	2.117	2.150	2.183	2.214	2.244	2.273	2.300	2.327	2.353	2.377	2.401	2.425	2.447	2.469	2.488	2.510
31	1.909	1.950	1.990	2.009	2.028	2.064	2.099	2.132	2.164	2.195	2.225	2.254	2.281	2.308	2.334	2.359	2.383	2.406	2.428	2.449	2.470	2.492
32	1.893	1.934	1.973	1.992	2.011	2.045	2.081	2.115	2.147	2.177	2.207	2.236	2.263	2.290	2.316	2.340	2.364	2.388	2.410	2.432	2.453	2.473
33	1.877	1.918	1.957	1.976	1.994	2.030	2.064	2.097	2.129	2.160	2.190	2.218	2.246	2.272	2.298	2.323	2.336	2.370	2.392	2.414	2.435	2.456
34	1.862	1.903	1.941	1.960	1.978	2.014	2.048	2.081	2.113	2.134	2.173	2.201	2.228	2.255	2.280	2.305	2.329	2.343	2.375	2.397	2.418	2.438
35	1.848	1.888	1.933	1.945	1.963	1.998	2.032	2.065	2.096	2.127	2.156	2.184	2.212	2.238	2.264	2.288	2.312	2.335	2.358	2.380	2.401	2.421
36	1.834	1.873	1.911	1.930	1.948	1.983	2.017	2.049	2.081	2.111	2.140	2.168	2.195	2.222	2.247	2.272	2.296	2.319	2.341	2.363	2.384	2.405
37	1.820	1.860	1.897	1.915	1.933	1.968	2.002	2.034	2.065	2.095	2.124	2.153	2.180	2.206	2.231	2.256	2.280	2.303	2.325	2.347	2.368	2.388
38	1.807	1.846	1.883	1.902	1.919	1.954	1.987	2.019	2.050	2.080	2.109	2.137	2.164	2.190	2.216	2.240	2.264	2.287	2.309	2.331	2.352	2.373
39	1.795	1.833	1.870	1.888	1.906	1.940	1.973	2.005	2.036	2.066	2.094	2.122	2.149	2.175	2.200	2.225	2.249	2.272	2.294	2.316	2.337	2.357
40	1.782	1.821	1.857	1.875	1.893	1.927	1.960	1.991	2.022	2.051	2.080	2.108	2.134	2.160	2.186	2.210	2.234	2.257	2.279	2.301	2.322	2.342
42	1.759	1.796	1.832	1.850	1.867	1.901	1.933	1.964	1.995	2.024	2.052	2.080	2.106	2.132	2.157	2.181	2.205	2.228	2.250	2.271	2.292	2.313
44	1.737	1.774	1.809	1.826	1.843	1.876	1.908	1.939	1.969	1.998	2.026	2.053	2.079	2.105	2.130	2.154	2.177	2.200	2.222	2.244	2.265	2.285
46	1.716	1.752	1.787	1.804	1.821	1.853	1.885	1.915	1.945	1.973	2.001	2.028	2.054	2.079	2.104	2.128	2.151	2.174	2.196	2.217	2.238	2.258
48	1.682	1.732	1.766	1.783	1.799	1.831	1.862	1.892	1.922	1.950	1.977	2.004	2.030	2.055	2.079	2.103	2.126	2.148	2.170	2.191	2.212	2.232
50	1.678	1.713	1.746	1.763	1.779	1.810	1.841	1.871	1.899	1.927	1.954	1.981	2.006	2.031	2.055	2.079	2.102	2.124	2.146	2.167	2.188	2.208
52	1.660	1.694	1.727	1.743	1.759	1.791	1.821	1.850	1.878	1.906	1.933	1.959	1.984	2.009	2.033	2.056	2.079	2.101	2.122	2.143	2.164	2.184
54	1.643	1.677	1.709	1.725	1.741	1.772	1.802	1.830	1.858	1.886	1.912	1.938	1.963	1.987	2.011	2.034	2.056	2.079	2.100	2.121	2.141	2.161
56	1.627	1.660	1.692	1.708	1.723	1.754	1.783	1.811	1.839	1.866	1.892	1.918	1.943	1.967	1.990	2.013	2.035	2.057	2.078	2.099	2.119	2.139
58	1.620	1.645	1.676	1.692	1.707	1.737	1.765	1.794	1.821	1.847	1.873	1.898	1.923	1.947	1.970	1.993	2.015	2.037	2.058	2.078	2.098	2.118
60	1.598	1.630	1.661	1.676	1.691	1.720	1.749	1.776	1.803	1.830	1.855	1.880	1.904	1.922	1.951	1.973	1.995	2.017	2.038	2.058	2.078	2.098
63	1.577	1.608	1.639	1.653	1.668	1.697	1.725	1.752	1.778	1.804	1.829	1.854	1.878	1.901	1.924	1.946	1.967	1.989	2.009	2.030	2.049	2.068
66	1.558	1.589	1.618	1.633	1.647	1.675	1.702	1.729	1.755	1.780	1.805	1.829	1.852	1.875	1.898	1.919	1.941	1.962	1.982	2.002	2.022	2.041
69	1.540	1.570	1.599	1.613	1.627	1.654	1.681	1.707	1.733	1.758	1.782	1.806	1.829	1.851	1.873	1.895	1.916	1.936	1.954	1.976	1.996	2.015
72	1.524	1.553	1.581	1.595	1.608	1.635	1.661	1.687	1.711	1.736	1.760	1.783	1.806	1.828	1.850	1.871	1.892	1.912	1.932	1.952	1.971	1.990
75	1.508	1.536	1.564	1.577	1.591	1.617	1.643	1.668	1.692	1.716	1.739	1.762	1.785	1.807	1.828	1.849	1.869	1.889	1.909	1.928	1.947	1.966
78	1.493	1.521	1.548	1.561	1.574	1.600	1.625	1.650	1.674	1.697	1.720	1.743	1.764	1.786	1.807	1.828	1.848	1.868	1.887	1.906	1.925	1.943
81	1.479	1.506	1.532	1.545	1.558	1.583	1.608	1.632	1.656	1.679	1.691	1.714	1.745	1.767	1.787	1.808	1.828	1.847	1.866	1.885	1.903	1.921
84	1.466	1.492	1.518	1.531	1.543	1.568	1.592	1.616	1.639	1.662	1.684	1.708	1.727	1.748	1.768	1.788	1.808	1.827	1.846	1.865	1.883	1.901
23	3.903	4.434	4.984	5.265	5.550	6.131	6.725	7.331	7.946	8.571	9.205	9.845	10.49	11.15	11.80	12.47	13.14	13.81	14.49	15.17	15.85	16.54
24	3.869	4.396	4.943	5.222	5.505	6.084	6.674	7.278	7.890	8.511	9.143	9.781	10.43	11.08	11.73	12.40	13.06	13.74	14.41	15.09	15.77	16.46
25	3.836	4.359	4.902	5.180	5.462	6.037	6.624	7.225	7.834	8.454	9.083	9.719	10.36	11.01	11.67	12.33	12.99	13.66	14.33	15.01	15.69	16.38
26	3.803	4.323	4.862	5.139	5.419	5.991	6.575	7.173	7.780	8.397	9.023	9.657	10.30	10.94	11.60	12.26	12.92	13.59	14.26	14.93	15.61	16.29
27	3.770	4.287	4.823	5.098	5.377	5.945	6.527	7.122	7.726	8.340	8.965	9.596	10.23	10.88	11.53	12.19	12.85	13.51	14.18	14.86	15.53	16.21
28	3.739	4.252	4.785	5.058	5.335	5.901	6.480	7.072	7.674	8.285	8.907	9.535	10.17	10.81	11.46	12.12	12.78	13.44	14.11	14.78	15.46	16.13
29	3.708	4.218	4.747	5.019	5.294	5.857	6.433	7.022	7.621	8.230	8.849	9.476	10.11	10.75	11.40	12.05	12.71	13.37	14.03	14.70	15.38	16.06
30	3.677	4.184	4.710	4.980	5.254	5.814	6.387	6.973	7.570	8.176	8.793	9.417	10.05	10.69	11.33	11.98	12.64	13.30	13.96	14.63	15.30	15.98
31	3.647	4.151	4.674	4.942	5.215	5.772	6.342	6.925	7.519	8.123	8.738	9.359	9.989	10.62	11.27	11.92	12.57	13.23	13.89	14.56	15.22	15.90
32	3.618	4.118	4.638	4.905	5.176	5.730	6.297	6.878	7.469	8.071	8.683	9.302	9.929	10.56	11.20	11.85	12.50	13.16	13.82	14.48	15.15	15.83
33	3.589	4.086	4.603	4.869	5.138	5.689	6.253	6.831	7.420	8.019	8.628	9.245	9.870	10.50	11.14	11.78	12.39	13.09	13.75	14.41	15.08	15.75
34	3.561	4.055	4.569	4.832	5.100	5.648	6.210	6.786	7.371	7.968	8.575	9.190	9.812	10.44	11.08	11.72	12.37	13.02	13.68	14.34	15.01	15.68
35	3.533	4.024	4.535	4.797	5.063	5.609	6.163	6.740	7.324	7.918	8.522	9.135	9.755	10.38	11.02	11.66	12.31	12.95	13.61	14.27	14.93	15.60
36	3.506	3.993	4.501	4.762	5.027	5.569	6.126	6.696	7.277	7.868	8.470	9.080	9.699	10.32	10.96	11.59	12.24	12.89	13.54	14.20	14.86	15.53
37	3.479	3.964	4.469	4.728	4.991	5.531	6.084	6.652	7.230	7.819	8.419	9.026	9.643	10.27	10.90	11.53	12.17	12.82	13.47	14.13	14.79	15.46
38																						

TABLE 5.- HAT-PANEL PROPERTIES $\left[\frac{tW}{t_S} = 0.79; \frac{bH}{b_W} = 0.8; \frac{bA}{t_W} = 17.17; \frac{bH}{t_W} = 0.8 \frac{bW}{t_W}; \frac{bR}{t_W} = 0.8 \frac{bW}{t_W} + 16.67; \frac{r}{t_W} = 3.13; \frac{d}{t_S} = 2.82; \frac{p}{t_S} = 12.30 \right]$ - Concluded

$\frac{b_W}{t_S}$	$\frac{b_W}{t_W}$	$\frac{h}{t_S}$																					
		19	21	23	24	25	27	29	31	33	35	37	39	41	43	45	47	49	51	53	55	57	59
42		3.352	3.822	4.312	4.564	4.821	5.346	5.886	6.441	7.007	7.583	8.171	8.768	9.373	9.985	10.61	11.23	11.86	12.50	13.15	13.79	14.45	15.10
44		3.305	3.768	4.253	4.502	4.756	5.276	5.811	6.360	6.921	7.493	8.077	8.669	9.270	9.877	10.49	11.12	11.75	12.38	13.02	13.66	14.31	14.97
46		3.258	3.716	4.196	4.442	4.693	5.208	5.742	6.282	6.838	7.405	7.984	8.572	9.169	9.772	10.38	11.00	11.63	12.26	12.90	13.53	14.18	14.83
48		3.214	3.666	4.140	4.384	4.632	5.142	5.667	6.206	6.757	7.320	7.894	8.478	9.070	9.669	10.28	10.89	11.51	12.14	12.77	13.41	14.06	14.70
50		3.170	3.618	4.086	4.327	4.573	5.078	5.597	6.132	6.678	7.236	7.806	8.385	8.973	9.569	10.17	10.78	11.40	12.03	12.65	13.29	13.93	14.57
52		3.128	3.570	4.033	4.272	4.516	5.015	5.530	6.069	6.601	7.155	7.720	8.295	8.879	9.470	10.07	10.68	11.29	11.91	12.54	13.17	13.81	14.45
54		3.088	3.524	3.983	4.219	4.460	4.954	5.464	5.989	6.526	7.075	7.636	8.207	8.787	9.374	9.970	10.57	11.18	11.80	12.42	13.05	13.69	14.32
56		3.048	3.480	3.933	4.167	4.405	4.895	5.400	5.920	6.453	6.998	7.555	8.121	8.697	9.280	9.872	10.47	11.08	11.69	12.31	12.94	13.57	14.20
58		2.996	3.437	3.885	4.116	4.352	4.837	5.338	5.853	6.382	6.922	7.475	8.036	8.603	9.188	9.776	10.37	10.98	11.59	12.20	12.82	13.45	14.08
60		2.973	3.395	3.838	4.067	4.301	4.781	5.277	5.788	6.312	6.848	7.396	7.954	8.522	9.127	9.682	10.28	10.87	11.48	12.09	12.71	13.33	13.96
63		2.919	3.334	3.771	3.996	4.226	4.699	5.188	5.693	6.210	6.740	7.282	7.833	8.395	8.965	9.544	10.13	10.73	11.33	11.93	12.55	13.17	13.79
66		2.868	3.276	3.705	3.928	4.154	4.621	5.103	5.601	6.112	6.635	7.171	7.717	8.273	8.837	9.411	9.993	10.58	11.18	11.78	12.39	13.00	13.62
69		2.819	3.220	3.643	3.862	4.085	4.545	5.021	5.513	6.017	6.534	7.064	7.604	8.155	8.713	9.281	9.858	10.44	11.03	11.63	12.23	12.84	13.46
72		2.772	3.167	3.583	3.798	4.019	4.472	4.942	5.427	5.923	6.437	6.961	7.495	8.039	8.592	9.155	9.726	10.30	10.89	11.48	12.08	12.69	13.30
75		2.728	3.115	3.525	3.737	3.954	4.402	4.865	5.344	5.837	6.342	6.860	7.389	7.928	8.475	9.032	9.599	10.17	10.75	11.34	11.93	12.53	13.14
78		2.683	3.065	3.469	3.679	3.893	4.334	4.791	5.264	5.751	6.250	6.763	7.286	7.819	8.361	8.914	9.475	10.04	10.62	11.20	11.79	12.39	12.99
81		2.641	3.018	3.416	3.622	3.833	4.268	4.720	5.187	5.668	6.162	6.671	7.186	7.714	8.251	8.798	9.354	9.917	10.49	11.07	11.65	12.24	12.84
84		2.600	2.971	3.364	3.567	3.775	4.205	4.651	5.125	5.588	6.076	6.577	7.089	7.612	8.144	8.685	9.236	9.794	10.36	10.93	11.51	12.10	12.69
23		5.390	6.064	6.741	7.081	7.418	8.095	8.773	9.449	10.13	10.80	11.47	12.15	12.82	13.49	14.16	14.83	15.50	16.16	16.83	17.50	18.16	18.82
24		5.374	6.047	6.723	7.062	7.401	8.078	8.754	9.432	10.11	10.78	11.46	12.13	12.80	13.48	14.15	14.81	15.48	16.15	16.82	17.48	18.15	18.81
25		5.357	6.023	6.706	7.044	7.383	8.060	8.737	9.414	10.09	10.77	11.44	12.11	12.79	13.46	14.13	14.80	15.47	16.14	16.80	17.47	18.13	18.80
26		5.342	6.014	6.689	7.027	7.365	8.042	8.719	9.396	10.07	10.75	11.42	12.10	12.77	13.44	14.11	14.78	15.45	16.12	16.79	17.45	18.12	18.78
27		5.325	5.997	6.671	7.009	7.347	8.024	8.701	9.378	10.05	10.73	11.40	12.08	12.75	13.43	14.10	14.77	15.44	16.10	16.77	17.44	18.10	18.76
28		5.309	5.980	6.654	6.992	7.330	8.007	8.683	9.360	10.04	10.71	11.39	12.06	12.74	13.41	14.08	14.75	15.42	16.09	16.76	17.42	18.09	18.75
29		5.293	5.963	6.637	6.974	7.312	7.989	8.665	9.342	10.02	10.69	11.37	12.04	12.72	13.39	14.06	14.73	15.40	16.07	16.74	17.41	18.07	18.74
30		5.277	5.947	6.620	6.957	7.295	7.971	8.647	9.324	10.00	10.68	11.35	12.03	12.70	13.37	14.05	14.72	15.39	16.06	16.72	17.39	18.06	18.72
31		5.261	5.930	6.603	6.939	7.279	7.953	8.629	9.306	9.983	10.66	11.33	12.01	12.68	13.36	14.03	14.70	15.37	16.04	16.71	17.38	18.04	18.71
32		5.245	5.914	6.586	6.922	7.260	7.935	8.612	9.288	9.964	10.64	11.32	11.99	12.67	13.34	14.01	14.68	15.35	16.02	16.69	17.36	18.03	18.69
33		5.230	5.897	6.569	6.905	7.242	7.918	8.594	9.270	9.946	10.62	11.30	11.97	12.65	13.32	13.99	14.67	15.33	16.01	16.68	17.34	18.01	18.68
34		5.214	5.881	6.552	6.888	7.225	7.900	8.576	9.252	9.928	10.60	11.28	11.95	12.63	13.30	13.98	14.65	15.32	15.99	16.66	17.33	18.00	18.66
35		5.198	5.865	6.535	6.871	7.208	7.882	8.558	9.234	9.910	10.59	11.26	11.94	12.61	13.29	13.96	14.63	15.30	15.97	16.64	17.31	17.98	18.65
36		5.183	5.849	6.518	6.854	7.191	7.865	8.540	9.216	9.892	10.57	11.24	11.92	12.59	13.27	13.94	14.61	15.29	15.96	16.63	17.30	17.97	18.63
37		5.168	5.833	6.502	6.837	7.174	7.847	8.522	9.198	9.874	10.55	11.23	11.90	12.58	13.25	13.93	14.60	15.27	15.94	16.61	17.28	17.95	18.62
38		5.152	5.817	6.485	6.820	7.156	7.830	8.504	9.180	9.856	10.53	11.21	11.88	12.56	13.23	13.91	14.58	15.25	15.92	16.59	17.26	17.93	18.60
39		5.137	5.801	6.468	6.803	7.139	7.812	8.487	9.162	9.838	10.51	11.19	11.86	12.54	13.21	13.89	14.56	15.23	15.91	16.58	17.25	17.92	18.58
40		5.122	5.785	6.452	6.786	7.122	7.795	8.469	9.144	9.820	10.50	11.17	11.85	12.52	13.20	13.87	14.54	15.22	15.89	16.56	17.23	17.90	18.57
42		5.093	5.753	6.419	6.753	7.088	7.760	8.433	9.108	9.783	10.46	11.13	11.81	12.49	13.16	13.83	14.51	15.18	15.85	16.53	17.20	17.87	18.53
44		5.063	5.722	6.386	6.720	7.055	7.726	8.398	9.072	9.747	10.42	11.10	11.77	12.45	13.12	13.80	14.47	15.15	15.82	16.49	17.16	17.83	18.50
46		5.034	5.691	6.354	6.687	7.021	7.691	8.361	9.037	9.711	10.39	11.06	11.74	12.41	13.09	13.76	14.44	15.11	15.78	16.46	17.13	17.80	18.47
48		5.005	5.661	6.322	6.655	6.988	7.657	8.328	9.001	9.675	10.35	11.02	11.70	12.38	13.05	13.73	14.40	15.07	15.75	16.42	17.09	17.76	18.43
50		4.977	5.635	6.291	6.622	6.955	7.623	8.293	8.965	9.640	10.31	10.99	11.66	12.34	13.01	13.69	14.36	15.04	15.71	16.38	17.06	17.73	18.40
52		4.949	5.601	6.259	6.591	6.923	7.590	8.259	8.930	9.604	10.28	10.95	11.63	12.30	12.98	13.65	14.33	15.00	15.68	16.35	17.02	17.69	18.36
54		4.921	5.572	6.229	6.559	6.891	7.556	8.225	8.896	9.568	10.24	10.92	11.59	12.27	12.94	13.62	14.29	14.97	15.64	16.31	16.99	17.66	18.33
56		4.894	5.543	6.198	6.528	6.859	7.523	8.191	8.861	9.533	10.21	10.88	11.55	12.23	12.90	13.58	14.25	14.93	15.60	16.28	16.95	17.62	18.29
58		4.866	5.514	6.168	6.497	6.827	7.490	8.157	8.826	9.498	10.17	10.84	11.52	12.19	12.87	13.54	14.22	14.89	15.57	16.24	16.91	17.59	18.26
60		4.841	5.486	6.138	6.466	6.796	7.458	8.124	8.792	9.463	10.14	10.81	11.48	12.16	12.84	13.51	14.18	14.86	15.53	16.20	16.88	17.55	18.22
63		4.802	5.444	6.093	6.431	6.749	7.410	8.074	8.741	9.410	10.08	10.75	11.43	12.10	12.78	13.45	14.13	14.80	15.47	16.15	16.82	17.50	18.17
66		4.763	5.403	6.050	6.376	6.704	7.362	8.025	8.690	9.359	10.03	10.70	11.37	12.05	12.72	13.40	14.07	14.74	15.42	16.09	16.77	17.44	18.11
69		4.707	5.362	6.007	6.332	6.659	7.316	7.978	8.640	9.308	9.977	10.65	11.32	12.02	12.67	13.34	14.01	14.69	15.36	16.04	16.71	17.39	18.06
72		4.689	5.323	5.965	6.289	6.615	7.269	7.928	8.591	9.258	9.925	10.59	11.26	11.94	12.61	13.29	13.96	14.63	15.31	15.98	16.66	17.33	18.00
75		4.65																					

TABLE 6.- HAT-PANEL PROPERTIES $\left[\frac{t_W}{t_S} = 1.00; \frac{b_H}{b_W} = 0.8; \frac{b_A}{t_W} = 15.75; \frac{b_H}{t_W} = 0.8 \frac{b_W}{t_W}; \frac{b_R}{t_W} = 0.8 \frac{b_W}{t_W} + 15.25; \frac{r}{t_W} = 3.13; \frac{d}{t_S} = 3.13; \frac{p}{t_S} = 12.50 \right]$

$\frac{b_W}{t_W} \backslash \frac{b_S}{t_S}$	19	21	23	24	25	27	29	31	33	35	37	39	41	43	45	47	49	51	53	55	57	59
23	2.470	2.529	2.585	2.612	2.638	2.688	2.735	2.780	2.823	2.863	2.902	2.939	2.974	3.008	3.040	3.071	3.101	3.129	3.156	3.183	3.208	3.232
24	2.443	2.502	2.558	2.584	2.610	2.660	2.707	2.754	2.795	2.836	2.874	2.911	2.947	2.981	3.013	3.044	3.074	3.102	3.130	3.156	3.182	3.206
25	2.417	2.476	2.531	2.557	2.583	2.633	2.680	2.725	2.768	2.809	2.848	2.885	2.920	2.954	2.987	3.018	3.048	3.076	3.104	3.131	3.156	3.181
26	2.392	2.450	2.505	2.532	2.557	2.607	2.654	2.699	2.742	2.783	2.821	2.859	2.894	2.928	2.961	2.992	3.022	3.051	3.079	3.106	3.131	3.156
27	2.367	2.425	2.480	2.507	2.532	2.582	2.629	2.674	2.716	2.757	2.796	2.833	2.869	2.903	2.936	2.967	2.997	3.026	3.054	3.081	3.107	3.140
28	2.344	2.402	2.456	2.482	2.508	2.557	2.605	2.649	2.692	2.732	2.771	2.809	2.844	2.878	2.911	2.943	2.973	3.002	3.030	3.057	3.083	3.108
29	2.321	2.379	2.433	2.459	2.485	2.534	2.581	2.625	2.668	2.708	2.747	2.785	2.820	2.854	2.887	2.919	2.949	2.979	3.010	3.034	3.060	3.085
30	2.299	2.356	2.410	2.436	2.462	2.511	2.557	2.602	2.644	2.685	2.724	2.761	2.797	2.831	2.864	2.896	2.920	2.956	2.984	3.011	3.037	3.063
31	2.278	2.335	2.388	2.414	2.440	2.488	2.535	2.579	2.622	2.662	2.701	2.738	2.774	2.808	2.841	2.873	2.904	2.933	2.961	2.989	3.015	3.041
32	2.258	2.314	2.367	2.393	2.418	2.467	2.513	2.557	2.600	2.640	2.679	2.716	2.752	2.786	2.819	2.851	2.882	2.911	2.939	2.967	2.993	3.019
33	2.238	2.293	2.347	2.372	2.397	2.446	2.492	2.536	2.578	2.618	2.657	2.694	2.730	2.765	2.798	2.829	2.860	2.890	2.918	2.946	2.972	2.998
34	2.218	2.274	2.327	2.352	2.377	2.425	2.471	2.515	2.557	2.597	2.636	2.673	2.709	2.743	2.776	2.808	2.839	2.868	2.897	2.925	2.951	2.977
35	2.200	2.255	2.307	2.333	2.357	2.405	2.451	2.495	2.537	2.577	2.616	2.653	2.688	2.723	2.756	2.788	2.818	2.848	2.877	2.904	2.931	2.957
36	2.182	2.236	2.288	2.314	2.338	2.386	2.431	2.475	2.517	2.557	2.596	2.633	2.668	2.703	2.736	2.767	2.798	2.828	2.856	2.884	2.911	2.937
37	2.164	2.218	2.270	2.295	2.320	2.367	2.412	2.456	2.498	2.539	2.576	2.613	2.649	2.683	2.716	2.748	2.778	2.808	2.837	2.864	2.891	2.917
38	2.147	2.201	2.252	2.277	2.302	2.349	2.394	2.437	2.479	2.519	2.557	2.594	2.629	2.664	2.697	2.728	2.759	2.789	2.817	2.845	2.872	2.898
39	2.130	2.184	2.235	2.260	2.284	2.331	2.376	2.419	2.460	2.500	2.538	2.575	2.611	2.643	2.676	2.710	2.740	2.770	2.799	2.826	2.853	2.879
40	2.114	2.167	2.218	2.243	2.267	2.314	2.358	2.401	2.442	2.482	2.520	2.557	2.592	2.626	2.659	2.691	2.722	2.752	2.780	2.808	2.835	2.861
42	2.084	2.136	2.186	2.210	2.234	2.280	2.324	2.367	2.408	2.447	2.485	2.522	2.557	2.592	2.624	2.655	2.686	2.716	2.744	2.772	2.799	2.825
44	2.064	2.106	2.155	2.179	2.203	2.248	2.292	2.334	2.375	2.414	2.452	2.488	2.523	2.557	2.590	2.621	2.651	2.681	2.710	2.738	2.765	2.791
46	2.027	2.078	2.126	2.150	2.173	2.218	2.261	2.303	2.343	2.382	2.420	2.456	2.491	2.524	2.557	2.588	2.619	2.648	2.677	2.705	2.732	2.758
48	2.000	2.051	2.099	2.122	2.145	2.189	2.232	2.274	2.313	2.352	2.389	2.425	2.459	2.493	2.525	2.557	2.587	2.617	2.645	2.673	2.700	2.726
50	1.976	2.025	2.072	2.095	2.118	2.162	2.204	2.245	2.285	2.323	2.360	2.395	2.430	2.463	2.495	2.526	2.557	2.586	2.615	2.642	2.669	2.695
52	1.952	2.000	2.047	2.070	2.092	2.136	2.178	2.218	2.257	2.295	2.331	2.367	2.401	2.434	2.466	2.497	2.527	2.557	2.585	2.613	2.639	2.666
54	1.929	1.977	2.023	2.046	2.068	2.111	2.152	2.192	2.231	2.268	2.304	2.340	2.373	2.406	2.438	2.469	2.499	2.528	2.557	2.584	2.611	2.637
56	1.908	1.955	2.000	2.022	2.044	2.087	2.128	2.167	2.206	2.243	2.279	2.313	2.347	2.380	2.411	2.442	2.472	2.501	2.529	2.557	2.583	2.609
58	1.887	1.934	1.979	2.000	2.022	2.064	2.104	2.143	2.181	2.218	2.254	2.288	2.322	2.354	2.385	2.416	2.446	2.475	2.503	2.530	2.557	2.582
60	1.867	1.913	1.958	1.979	2.000	2.042	2.082	2.121	2.158	2.194	2.230	2.264	2.297	2.329	2.361	2.391	2.420	2.449	2.477	2.504	2.531	2.557
63	1.840	1.884	1.928	1.949	1.970	2.010	2.050	2.088	2.126	2.161	2.188	2.223	2.256	2.294	2.325	2.355	2.384	2.413	2.440	2.467	2.494	2.519
66	1.813	1.857	1.900	1.920	1.941	1.981	2.019	2.057	2.093	2.129	2.145	2.182	2.219	2.260	2.291	2.321	2.350	2.378	2.405	2.432	2.458	2.484
69	1.789	1.832	1.873	1.894	1.914	1.953	1.991	2.028	2.064	2.098	2.132	2.165	2.197	2.228	2.259	2.288	2.317	2.345	2.372	2.399	2.425	2.450
72	1.766	1.808	1.849	1.868	1.888	1.927	1.964	2.000	2.036	2.070	2.103	2.136	2.167	2.198	2.228	2.257	2.285	2.313	2.340	2.367	2.392	2.417
75	1.744	1.785	1.825	1.845	1.864	1.902	1.938	1.974	2.009	2.043	2.076	2.108	2.139	2.169	2.199	2.227	2.255	2.283	2.310	2.336	2.361	2.386
78	1.723	1.764	1.803	1.822	1.841	1.878	1.914	1.949	1.984	2.017	2.049	2.081	2.112	2.142	2.171	2.199	2.227	2.254	2.281	2.307	2.332	2.357
81	1.704	1.743	1.782	1.801	1.819	1.856	1.891	1.926	1.959	1.992	2.024	2.055	2.086	2.115	2.144	2.172	2.200	2.227	2.253	2.279	2.304	2.328
84	1.685	1.724	1.762	1.780	1.799	1.835	1.869	1.903	1.937	1.969	2.000	2.031	2.061	2.090	2.119	2.147	2.174	2.200	2.226	2.252	2.277	2.301
23	5.557	6.325	7.116	7.511	7.927	8.754	9.597	10.45	11.32	12.20	13.08	13.98	14.88	15.79	16.70	17.62	18.54	19.47	20.40	21.34	22.28	23.22
24	5.519	6.284	7.068	7.465	7.875	8.703	9.543	10.40	11.26	12.14	13.02	13.91	14.81	15.72	16.63	17.55	18.47	19.40	20.33	21.26	22.20	23.14
25	5.481	6.242	7.022	7.419	7.824	8.653	9.490	10.34	11.20	12.07	12.96	13.85	14.74	15.65	16.56	17.47	18.39	19.30	20.25	21.18	22.12	23.06
26	5.444	6.202	6.978	7.373	7.774	8.603	9.437	10.29	11.14	12.01	12.89	13.78	14.68	15.58	16.49	17.40	18.32	19.24	20.17	21.10	22.04	22.98
27	5.408	6.162	6.927	7.322	7.725	8.554	9.385	10.23	11.09	11.95	12.83	13.72	14.61	15.51	16.42	17.33	18.25	19.17	20.10	21.03	21.96	22.90
28	5.372	6.123	6.881	7.284	7.676	8.506	9.332	10.18	11.03	11.90	12.77	13.65	14.55	15.44	16.35	17.26	18.17	19.10	20.02	20.95	21.88	22.82
29	5.336	6.084	6.835	7.241	7.628	8.457	9.282	10.12	10.97	11.84	12.71	13.59	14.48	15.38	16.28	17.19	18.10	19.02	19.94	20.87	21.80	22.74
30	5.302	6.045	6.791	7.198	7.580	8.409	9.232	10.07	10.92	11.78	12.65	13.53	14.42	15.31	16.21	17.12	18.03	18.95	19.87	20.80	21.73	22.66
31	5.267	6.008	6.747	7.155	7.533	8.362	9.183	10.02	10.86	11.72	12.59	13.47	14.35	15.25	16.14	17.05	17.96	18.88	19.80	20.72	21.65	22.58
32	5.233	5.970	6.703	7.113	7.487	8.316	9.133	9.965	10.81	11.67	12.53	13.41	14.29	15.18	16.08	16.98	17.89	18.80	19.72	20.65	21.57	22.50
33	5.200	5.934	6.660	7.072	7.441	8.270	9.085	9.914	10.76	11.61	12.47	13.35	14.23	15.12	16.01	16.91	17.82	18.73	19.65	20.57	21.50	22.43
34	5.167	5.897	6.618	7.031	7.395	8.224	9.037	9.863	10.70	11.55	12.42	13.29	14.17	15.05	15.95	16.85	17.71	18.66	19.58	20.50	21.42	22.35
35	5.134	5.861	6.576	6.990	7.351	8.179	8.989	9.813	10.66	11.50	12.36	13.23	14.11	14.99	15.88	16.78	17.68	18.59	19.51	20.42	21.35	22.27
36	5.102	5.826	6.534	6.950	7.306	8.135	8.942	9.764	10.60	11.44	12.30	13.17	14.04	14.93	15.82	16.71	17.61	18.52	19.43	20.35	21.27	22.20
37	5.071	5.791	6.494	6.911	7.263	8.092	8.896	9.714	10.55	11.39	12.25	13.11	13.98	14.86	15.75	16.65	17.55	18.45	19.36	20.28	21.20	22.12
38																						

TABLE 6.- HAT-PANEL PROPERTIES $\left[\frac{t_W}{t_S} = 1.00; \frac{b_H}{b_W} = 0.8; \frac{b_A}{t_W} = 15.75; \frac{b_H}{t_W} = 0.8 \frac{b_W}{t_W}; \frac{b_R}{t_W} = 0.8 \frac{b_W}{t_W} + 15.25; \frac{r}{t_W} = 3.13; \frac{d}{t_S} = 3.13; \frac{p}{t_S} = 12.50 \right]$ - Concluded

$\frac{b_W}{b_S} \frac{t_W}{t_S}$	19	21	23	24	25	27	29	31	33	35	37	39	41	43	45	47	49	51	53	55	57	59
42	4.919	5.624	6.297	6.721	7.052	7.380	8.671	9.477	10.30	11.13	11.97	12.83	13.69	14.56	15.44	16.33	17.22	18.12	19.02	19.93	20.84	21.76
44	4.861	5.559	6.221	6.648	6.971	7.799	8.584	9.385	10.20	11.03	11.87	12.72	13.58	14.44	15.32	16.20	17.09	17.98	18.88	19.79	20.77	21.61
46	4.804	5.497	6.148	6.576	6.892	7.719	8.499	9.295	10.11	10.93	11.76	12.61	13.46	14.33	15.20	16.08	16.96	17.85	18.75	19.65	20.56	21.47
48	4.749	5.438	6.076	6.507	6.814	7.641	8.416	9.207	10.01	10.83	11.66	12.50	13.35	14.21	15.08	15.96	16.84	17.73	18.62	19.52	20.42	21.33
50	4.696	5.376	6.005	6.439	6.739	7.565	8.334	9.121	9.921	10.74	11.56	12.40	13.25	14.10	14.97	15.84	16.72	17.60	18.49	19.39	20.29	21.19
52	4.643	5.318	5.937	6.372	6.665	7.490	8.255	9.036	9.832	10.64	11.46	12.30	13.14	13.99	14.85	15.72	16.59	17.48	18.36	19.26	20.16	21.05
54	4.592	5.261	5.870	6.307	6.592	7.417	8.177	8.953	9.744	10.55	11.37	12.20	13.04	13.88	14.74	15.60	16.48	17.35	18.24	19.13	20.02	20.92
56	4.543	5.206	5.804	6.244	6.521	7.346	8.100	8.872	9.668	10.46	11.27	12.10	12.93	13.78	14.63	15.49	16.36	17.23	18.12	19.00	19.89	20.79
58	4.494	5.152	5.740	6.181	6.452	7.275	8.025	8.792	9.574	10.37	11.18	12.00	12.83	13.67	14.52	15.38	16.24	17.12	17.99	18.88	19.77	20.66
60	4.447	5.099	5.677	6.120	6.384	7.207	7.951	8.714	9.491	10.28	11.09	11.90	12.73	13.57	14.41	15.27	16.13	17.00	17.87	18.75	19.64	20.53
63	4.378	5.022	5.585	6.031	6.285	7.106	7.844	8.599	9.369	10.15	11.00	11.76	12.59	13.42	14.26	15.10	15.96	16.83	17.70	18.57	19.45	20.34
66	4.311	4.947	5.497	5.945	6.189	7.009	7.739	8.487	9.251	10.03	10.91	11.63	12.44	13.27	14.10	14.95	15.80	16.66	17.52	18.39	19.27	20.16
69	4.247	4.875	5.411	5.862	6.096	6.914	7.637	8.379	9.136	9.908	10.69	11.49	12.30	13.12	13.95	14.79	15.64	16.49	17.35	18.22	19.09	19.97
72	4.184	4.805	5.328	5.781	6.005	6.822	7.538	8.273	9.024	9.790	10.57	11.36	12.17	12.98	13.80	14.64	15.48	16.33	17.18	18.05	18.91	19.79
75	4.124	4.737	5.247	5.702	5.917	6.733	7.442	8.170	8.914	9.674	10.45	11.23	12.03	12.84	13.66	14.49	15.33	16.17	17.02	17.88	18.74	19.62
78	4.066	4.671	5.169	5.626	5.832	6.646	7.349	8.070	8.808	9.561	10.33	11.11	11.90	12.71	13.52	14.34	15.17	16.01	16.86	17.71	18.58	19.44
81	4.009	4.608	5.092	5.552	5.749	6.562	7.258	7.972	8.704	9.451	10.21	10.99	11.78	12.57	13.38	14.20	15.03	15.86	16.70	17.55	18.41	19.27
84	3.955	4.546	5.019	5.480	5.669	6.480	7.169	7.877	8.603	9.344	10.10	10.87	11.65	12.44	13.25	14.06	14.88	15.71	16.55	17.39	18.25	19.10
23	7.141	8.007	8.872	9.310	9.736	10.80	11.46	12.31	13.17	14.02	14.86	15.71	16.56	17.40	18.24	19.08	19.91	20.75	21.58	22.41	23.24	24.07
24	7.127	7.993	8.861	9.297	9.724	10.58	11.44	12.30	13.15	14.01	14.85	15.70	16.55	17.39	18.23	19.07	19.90	20.74	21.57	22.40	23.23	24.06
25	7.114	7.980	8.849	9.283	9.713	10.57	11.43	12.29	13.14	13.99	14.84	15.69	16.54	17.38	18.22	19.06	19.90	20.73	21.57	22.40	23.23	24.06
26	7.100	7.966	8.838	9.269	9.702	10.56	11.42	12.27	13.13	13.98	14.83	15.68	16.52	17.37	18.21	19.05	19.89	20.72	21.56	22.39	23.22	24.05
27	7.086	7.953	8.826	9.256	9.691	10.54	11.40	12.26	13.12	13.97	14.82	15.67	16.52	17.36	18.20	19.04	19.88	20.72	21.55	22.38	23.22	24.05
28	7.073	7.939	8.815	9.242	9.679	10.53	11.39	12.25	13.11	13.96	14.81	15.66	16.50	17.35	18.19	19.03	19.87	20.71	21.54	22.38	23.21	24.04
29	7.059	7.925	8.803	9.228	9.668	10.52	11.38	12.24	13.09	13.95	14.80	15.65	16.49	17.34	18.18	19.03	19.86	20.70	21.54	22.37	23.20	24.03
30	7.046	7.911	8.791	9.214	9.656	10.50	11.36	12.22	13.08	13.93	14.79	15.64	16.48	17.33	18.17	19.01	19.85	20.69	21.53	22.36	23.20	24.03
31	7.032	7.898	8.774	9.200	9.644	10.49	11.35	12.21	13.07	13.92	14.77	15.62	16.47	17.32	18.16	19.00	19.84	20.68	21.52	22.36	23.19	24.02
32	7.019	7.884	8.768	9.187	9.632	10.48	11.34	12.20	13.06	13.91	14.76	15.61	16.46	17.31	18.15	19.00	19.84	20.67	21.51	22.35	23.18	24.01
33	7.005	7.870	8.756	9.173	9.620	10.46	11.32	12.18	13.04	13.90	14.75	15.60	16.45	17.30	18.14	18.99	19.83	20.67	21.50	22.34	23.18	24.01
34	6.991	7.856	8.744	9.159	9.608	10.45	11.31	12.17	13.03	13.88	14.74	15.59	16.44	17.29	18.13	18.98	19.82	20.66	21.50	22.33	23.17	24.00
35	6.978	7.842	8.731	9.145	9.596	10.44	11.30	12.16	13.02	13.87	14.73	15.58	16.43	17.28	18.12	18.97	19.81	20.65	21.49	22.32	23.16	23.99
36	6.964	7.828	8.719	9.131	9.583	10.42	11.28	12.14	13.00	13.86	14.71	15.57	16.42	17.28	18.11	18.95	19.80	20.64	21.48	22.32	23.15	23.99
37	6.951	7.815	8.707	9.117	9.571	10.41	11.27	12.13	12.99	13.85	14.70	15.55	16.40	17.25	18.10	18.94	19.79	20.63	21.47	22.31	23.14	23.98
38	6.937	7.801	8.695	9.102	9.559	10.39	11.26	12.12	12.97	13.83	14.69	15.54	16.39	17.24	18.09	18.93	19.78	20.62	21.46	22.30	23.14	23.97
39	6.924	7.787	8.682	9.088	9.547	10.38	11.24	12.10	12.96	13.82	14.68	15.53	16.38	17.23	18.08	18.92	19.77	20.61	21.45	22.29	23.13	23.96
40	6.910	7.773	8.670	9.074	9.534	10.37	11.23	12.09	12.95	13.81	14.66	15.52	16.37	17.22	18.07	18.91	19.76	20.60	21.44	22.28	23.12	23.96
42	6.894	7.746	8.645	9.046	9.509	10.34	11.20	12.06	12.92	13.78	14.64	15.49	16.34	17.19	18.04	18.89	19.74	20.58	21.42	22.26	23.10	23.94
44	6.857	7.718	8.620	9.018	9.483	10.31	11.17	12.03	12.89	13.75	14.61	15.47	16.32	17.17	18.02	18.87	19.71	20.56	21.40	22.24	23.09	23.92
46	6.830	7.691	8.594	8.990	9.458	10.28	11.15	12.01	12.87	13.73	14.58	15.44	16.29	17.15	18.00	18.84	19.69	20.54	21.38	22.22	23.06	23.90
48	6.804	7.663	8.569	8.961	9.432	10.25	11.12	11.98	12.84	13.70	14.55	15.41	16.28	17.12	17.97	18.82	19.67	20.51	21.36	22.20	23.04	23.88
50	6.777	7.636	8.544	8.933	9.407	10.22	11.09	11.95	12.81	13.67	14.53	15.37	16.24	17.09	17.95	18.80	19.65	20.49	21.34	22.18	23.02	23.86
52	6.751	7.609	8.518	8.906	9.381	10.20	11.06	11.92	12.78	13.64	14.50	15.36	16.21	17.07	17.92	18.77	19.62	20.47	21.32	22.16	23.00	23.84
54	6.725	7.582	8.493	8.877	9.355	10.17	11.01	11.89	12.75	13.62	14.47	15.33	16.19	17.03	17.90	18.75	19.60	20.45	21.29	22.14	23.00	23.82
56	6.699	7.555	8.467	8.850	9.329	10.14	11.00	11.86	12.73	13.59	14.45	15.30	16.16	17.02	17.87	18.72	19.57	20.42	21.27	22.12	22.96	23.80
58	6.673	7.528	8.441	8.818	9.303	10.11	10.97	11.83	12.70	13.56	14.42	15.28	16.13	16.99	17.84	18.70	19.55	20.40	21.25	22.09	22.94	23.78
60	6.648	7.501	8.416	8.793	9.276	10.08	10.94	11.81	12.67	13.53	14.39	15.25	16.11	16.96	17.82	18.67	19.52	20.37	21.22	22.07	22.92	23.76
63	6.610	7.462	8.378	8.751	9.237	10.04	10.90	11.76	12.63	13.49	14.36	15.21	16.07	16.92	17.78	18.63	19.48	20.36	21.19	22.03	22.88	23.73
66	6.572	7.422	8.340	8.710	9.198	9.996	10.86	11.72	12.58	13.44	14.33	15.16	16.02	16.88	17.74	18.59	19.45	20.30	21.15	22.00	22.85	23.69
69	6.535	7.383	8.302	8.669	9.160	9.954	10.81	11.68	12.54	13.40	14.26	15.12	15.98	16.84	17.70	18.56	19.41	20.26	21.11	21.96	22.81	23.66
72	6.498	7.345	8.264	8.628	9.120	9.912	10.77	11.63	12.50	13.36	14.22	15.08	15.94	16.80	17.65	18.51	19.37	20.22	21.07	21.92	22.77	23.62
75	6.462	7.307	8.226	8.585	9.081	9.870	10.73	11.59	12.45	13.31	14.18	15.04	15.90	16.76	17.61	18.47	19.32	20.18	21.03	21.89	22.76	23.58
78																						

TABLE 7.- HAT-PANEL PROPERTIES $\left[\frac{t_W}{t_S} = 1.25; \frac{b_H}{b_W} = 0.8; \frac{b_A}{t_W} = 13.25; \frac{b_H}{t_W} = 0.8 \frac{b_W}{t_W}; \frac{b_R}{t_W} = 0.8 \frac{b_W}{t_W} + 12.75; \frac{r}{t_W} = 3.13; \frac{d}{t_S} = 2.93; \frac{p}{t_S} = 11.72 \right]$

$\frac{b_W}{t_W}$																						
$\frac{b_S}{t_S}$	19	21	23	24	25	27	29	31	33	35	37	39	41	43	45	47	49	51	53	55	57	59
23	2.985	3.066	3.140	3.175	3.210	3.276	3.338	3.396	3.452	3.504	3.553	3.600	3.645	3.687	3.727	3.766	3.803	3.838	3.871	3.903	3.934	3.964
24	2.951	3.031	3.106	3.141	3.176	3.242	3.304	3.363	3.418	3.470	3.520	3.567	3.612	3.655	3.695	3.734	3.771	3.806	3.840	3.879	3.904	3.934
25	2.918	2.998	3.073	3.108	3.143	3.209	3.271	3.330	3.385	3.438	3.488	3.535	3.580	3.623	3.664	3.703	3.740	3.776	3.810	3.843	3.874	3.904
26	2.887	2.966	3.041	3.076	3.111	3.177	3.239	3.298	3.353	3.406	3.456	3.504	3.549	3.592	3.633	3.672	3.710	3.746	3.780	3.813	3.845	3.875
27	2.856	2.935	3.010	3.045	3.079	3.145	3.208	3.266	3.322	3.375	3.425	3.473	3.518	3.562	3.603	3.643	3.680	3.717	3.751	3.784	3.816	3.847
28	2.826	2.905	2.979	3.015	3.049	3.115	3.177	3.236	3.292	3.345	3.395	3.443	3.489	3.532	3.574	3.613	3.651	3.688	3.723	3.756	3.788	3.819
29	2.798	2.876	2.950	2.985	3.020	3.085	3.148	3.206	3.262	3.315	3.366	3.414	3.460	3.503	3.545	3.585	3.623	3.660	3.695	3.729	3.761	3.792
30	2.770	2.848	2.922	2.957	2.991	3.057	3.119	3.178	3.234	3.287	3.337	3.385	3.431	3.475	3.517	3.557	3.595	3.632	3.668	3.701	3.734	3.765
31	2.743	2.821	2.894	2.929	2.963	3.029	3.091	3.150	3.206	3.259	3.309	3.357	3.403	3.447	3.489	3.530	3.568	3.605	3.641	3.675	3.708	3.739
32	2.717	2.794	2.867	2.902	2.936	3.002	3.064	3.122	3.178	3.231	3.282	3.330	3.376	3.420	3.463	3.503	3.542	3.579	3.615	3.649	3.682	3.714
33	2.692	2.769	2.841	2.876	2.910	2.975	3.037	3.096	3.152	3.205	3.255	3.304	3.350	3.394	3.436	3.477	3.516	3.553	3.589	3.623	3.656	3.688
34	2.667	2.744	2.816	2.850	2.885	2.950	3.011	3.070	3.126	3.179	3.229	3.278	3.324	3.368	3.411	3.451	3.490	3.528	3.564	3.598	3.632	3.664
35	2.643	2.719	2.791	2.825	2.860	2.924	2.986	3.044	3.100	3.153	3.204	3.252	3.299	3.343	3.385	3.426	3.465	3.503	3.539	3.574	3.607	3.639
36	2.620	2.696	2.767	2.802	2.836	2.900	2.961	3.020	3.075	3.128	3.179	3.227	3.274	3.318	3.361	3.402	3.441	3.478	3.515	3.550	3.583	3.616
37	2.597	2.673	2.744	2.778	2.812	2.876	2.937	2.996	3.051	3.104	3.155	3.203	3.250	3.294	3.337	3.377	3.417	3.455	3.491	3.526	3.560	3.592
38	2.575	2.650	2.721	2.755	2.789	2.853	2.914	2.972	3.027	3.080	3.131	3.179	3.226	3.270	3.313	3.354	3.393	3.431	3.468	3.503	3.536	3.569
39	2.554	2.628	2.699	2.733	2.766	2.830	2.891	2.949	3.004	3.057	3.108	3.156	3.203	3.247	3.290	3.331	3.370	3.408	3.445	3.480	3.514	3.547
40	2.533	2.607	2.678	2.711	2.744	2.808	2.869	2.927	2.982	3.035	3.085	3.133	3.180	3.224	3.267	3.308	3.348	3.386	3.422	3.457	3.491	3.524
42	2.493	2.568	2.636	2.669	2.702	2.765	2.826	2.883	2.938	2.991	3.041	3.089	3.136	3.180	3.223	3.264	3.304	3.342	3.378	3.414	3.448	3.481
44	2.455	2.528	2.596	2.629	2.662	2.725	2.784	2.842	2.896	2.949	2.999	3.047	3.093	3.138	3.180	3.221	3.261	3.299	3.336	3.372	3.406	3.439
46	2.419	2.491	2.559	2.591	2.624	2.686	2.745	2.802	2.856	2.908	2.958	3.006	3.052	3.097	3.139	3.181	3.220	3.259	3.295	3.331	3.366	3.399
48	2.385	2.455	2.523	2.555	2.587	2.649	2.707	2.764	2.818	2.870	2.919	2.967	3.013	3.057	3.100	3.141	3.181	3.219	3.256	3.292	3.326	3.360
50	2.352	2.422	2.488	2.520	2.552	2.613	2.671	2.727	2.781	2.832	2.882	2.930	2.975	3.020	3.062	3.103	3.143	3.181	3.218	3.254	3.288	3.322
52	2.306	2.390	2.456	2.487	2.519	2.579	2.637	2.692	2.746	2.797	2.849	2.893	2.939	2.983	3.026	3.067	3.108	3.144	3.181	3.217	3.252	3.285
54	2.291	2.359	2.424	2.455	2.487	2.546	2.604	2.659	2.712	2.762	2.811	2.859	2.904	2.948	2.990	3.031	3.071	3.109	3.146	3.182	3.216	3.250
56	2.263	2.330	2.394	2.425	2.456	2.515	2.572	2.626	2.679	2.729	2.778	2.825	2.870	2.914	2.956	2.997	3.036	3.074	3.111	3.147	3.182	3.215
58	2.235	2.302	2.365	2.396	2.426	2.485	2.541	2.595	2.647	2.698	2.746	2.793	2.838	2.881	2.923	2.964	3.003	3.041	3.078	3.114	3.148	3.182
60	2.209	2.275	2.338	2.368	2.398	2.456	2.512	2.565	2.617	2.667	2.715	2.761	2.806	2.849	2.891	2.932	2.971	3.009	3.046	3.081	3.116	3.149
63	2.172	2.236	2.298	2.328	2.357	2.415	2.470	2.523	2.574	2.623	2.670	2.716	2.761	2.804	2.845	2.886	2.925	2.962	2.999	3.035	3.069	3.103
66	2.137	2.200	2.261	2.290	2.319	2.376	2.430	2.482	2.532	2.582	2.628	2.674	2.718	2.760	2.802	2.842	2.880	2.918	2.955	2.990	3.024	3.058
69	2.104	2.166	2.226	2.255	2.283	2.339	2.392	2.444	2.493	2.542	2.588	2.633	2.677	2.719	2.760	2.800	2.838	2.876	2.912	2.947	2.982	3.015
72	2.073	2.134	2.193	2.221	2.249	2.304	2.356	2.407	2.456	2.504	2.550	2.595	2.638	2.680	2.720	2.760	2.798	2.835	2.871	2.906	2.940	2.974
75	2.044	2.104	2.161	2.189	2.217	2.270	2.322	2.372	2.421	2.468	2.514	2.558	2.600	2.642	2.682	2.721	2.759	2.796	2.832	2.867	2.901	2.934
78	2.016	2.075	2.131	2.159	2.186	2.239	2.290	2.339	2.387	2.434	2.479	2.522	2.565	2.606	2.646	2.685	2.722	2.759	2.794	2.829	2.863	2.896
81	1.990	2.047	2.103	2.130	2.157	2.209	2.259	2.308	2.355	2.401	2.446	2.489	2.531	2.571	2.611	2.649	2.687	2.723	2.759	2.793	2.827	2.860
84	1.965	2.021	2.076	2.103	2.129	2.180	2.230	2.279	2.325	2.370	2.414	2.457	2.500	2.538	2.578	2.616	2.653	2.689	2.724	2.758	2.792	2.824
23	7.905	8.990	10.10	10.66	11.23	12.38	13.54	14.72	15.91	17.11	18.31	19.53	20.75	21.98	23.21	24.45	25.69	26.94	28.20	29.45	30.70	31.96
24	7.862	8.944	10.05	10.61	11.18	12.33	13.49	14.66	15.85	17.04	18.25	19.46	20.68	21.91	23.14	24.38	25.62	26.86	28.11	29.37	30.62	31.88
25	7.820	8.898	10.00	10.56	11.13	12.27	13.43	14.60	15.79	16.98	18.18	19.39	20.61	21.84	23.07	24.30	25.54	26.79	28.04	29.29	30.54	31.80
26	7.778	8.853	9.954	10.51	11.08	12.22	13.37	14.54	15.72	16.92	18.12	19.33	20.54	21.77	23.00	24.23	25.47	26.71	27.96	29.21	30.46	31.72
27	7.737	8.808	9.906	10.46	11.03	12.16	13.32	14.48	15.66	16.85	18.05	19.25	20.48	21.70	22.93	24.16	25.40	26.64	27.88	29.13	30.39	31.64
28	7.696	8.764	9.859	10.41	10.98	12.11	13.26	14.43	15.60	16.79	17.99	19.20	20.41	21.63	22.85	24.09	25.32	26.56	27.81	29.06	30.31	31.56
29	7.656	8.721	9.812	10.37	10.93	12.06	13.21	14.37	15.54	16.73	17.93	19.13	20.34	21.56	22.78	24.01	25.25	26.49	27.73	28.98	30.23	31.48
30	7.616	8.677	9.766	10.32	10.88	12.01	13.15	14.31	15.49	16.67	17.86	19.07	20.27	21.49	22.71	23.94	25.18	26.41	27.66	28.90	30.15	31.40
31	7.576	8.634	9.720	10.27	10.83	11.95	13.10	14.26	15.43	16.61	17.80	19.00	20.21	21.42	22.64	23.87	25.10	26.34	27.58	28.83	30.07	31.33
32	7.537	8.592	9.674	10.22	10.78	11.90	13.04	14.20	15.37	16.55	17.74	18.92	20.14	21.36	22.58	23.80	25.03	26.27	27.51	28.75	30.00	31.25
33	7.499	8.550	9.629	10.18	10.73	11.85	12.99	14.14	15.31	16.49	17.68	18.87	20.08	21.29	22.51	23.73	24.96	26.19	27.43	28.68	29.92	31.17
34	7.460	8.508	9.585	10.13	10.68	11.80	12.94	14.09	15.25	16.43	17.61	18.81	20.01	21.22	22.44	23.66	24.89	26.12	27.36	28.60	29.85	31.09
35	7.423	8.467	9.540	10.09	10.64	11.75	12.89	14.03	15.20	16.37	17.55	18.75	19.95	21.16	22.37	23.59	24.82	26.05	27.29	28.53	29.77	31.02
36	7.385	8.427	9.497	10.04	10.59	11.70	12.83	13.98	15.14	16.31	17.49	18.68	19.88	21.09	22.30	23.52	24.75	25.98	27.21	28.45	29.69	30.94
37	7.348	8.387	9.453	9.996	10.54	11.65	12.78	13.93	15.08	16.25	17.43	18.60	19.82	21.03	22.24	23.46	24.68	25.91	27.14	28.38	29.62	30.87
38																						

TABLE 7.- HAT-PANEL PROPERTIES $\left[\frac{t_W}{t_S} = 1.25; \frac{b_H}{b_W} = 0.8; \frac{b_A}{t_W} = 13.25; \frac{b_H}{t_W} = 0.8 \frac{b_W}{t_W}; \frac{b_R}{t_W} = 0.8 \frac{b_W}{t_W} + 12.75; \frac{r}{t_W} = 3.13; \frac{d}{t_S} = 2.93; \frac{p}{t_S} = 11.72 \right]$ - Concluded

$\frac{b_W}{t_S}$	$\frac{b_S}{t_S}$	$\frac{h}{t_S}$																					
		19	21	23	24	25	27	29	31	33	35	37	39	41	43	45	47	49	51	53	55	57	59
42		7.169	8.191	9.243	9.778	10.32	11.42	12.53	13.66	14.81	15.97	17.14	18.32	19.51	20.70	21.91	23.12	24.34	25.56	26.78	28.02	29.25	30.49
44		7.100	8.116	9.161	9.694	10.23	11.32	12.44	13.56	14.70	15.86	17.02	18.17	19.39	20.58	21.78	22.99	24.20	25.42	26.65	27.87	29.11	30.34
46		7.032	8.042	9.082	9.611	10.15	11.23	12.34	13.46	14.60	15.75	16.91	18.06	19.27	20.46	21.65	22.86	24.07	25.28	26.51	27.73	28.96	30.20
48		6.966	7.969	8.903	9.530	10.06	11.14	12.24	13.36	14.50	15.64	16.80	17.97	19.15	20.33	21.53	22.73	23.94	25.15	26.37	27.59	28.82	30.05
50		6.901	7.898	8.926	9.450	9.979	11.06	12.15	13.26	14.39	15.54	16.69	17.85	19.03	20.21	21.40	22.60	23.81	25.02	26.23	27.46	28.68	29.91
52		6.838	7.828	8.850	9.371	9.898	10.97	12.06	13.17	14.29	15.43	16.59	17.74	18.91	20.09	21.28	22.48	23.68	24.89	26.10	27.32	28.54	29.77
54		6.775	7.760	8.778	9.294	9.818	10.88	11.97	13.07	14.19	15.33	16.47	17.63	18.80	19.98	21.16	22.35	23.55	24.76	25.97	27.18	28.41	29.63
56		6.714	7.693	8.703	9.218	9.740	10.80	11.88	12.98	14.10	15.23	16.37	17.52	18.69	19.86	21.04	22.23	23.43	24.63	25.84	27.05	28.27	29.49
58		6.654	7.627	8.631	9.144	9.662	10.72	11.79	12.89	14.00	15.12	16.26	17.41	18.57	19.74	20.92	22.11	23.30	24.50	25.71	26.92	28.13	29.35
60		6.595	7.562	8.561	9.071	9.587	10.64	11.71	12.80	13.91	15.03	16.16	17.31	18.46	19.63	20.80	21.99	23.18	24.37	25.58	26.79	28.00	29.22
63		6.509	7.467	8.457	8.963	9.475	10.52	11.58	12.67	13.77	14.88	16.01	17.15	18.30	19.46	20.63	21.81	23.00	24.19	25.39	26.59	27.80	29.02
66		6.425	7.374	8.356	8.858	9.366	10.40	11.46	12.53	13.63	14.74	15.86	16.99	18.14	19.30	20.46	21.63	22.82	24.00	25.20	26.40	27.61	28.82
69		6.344	7.284	8.258	8.756	9.260	10.29	11.34	12.41	13.49	14.60	15.71	16.84	17.98	19.13	20.29	21.46	22.64	23.82	25.01	26.21	27.41	28.62
72		6.265	7.196	8.162	8.656	9.156	10.18	11.22	12.28	13.36	14.46	15.57	16.69	17.83	18.97	20.13	21.29	22.47	23.65	24.83	26.03	27.22	28.43
75		6.186	7.111	8.069	8.559	9.055	10.07	11.10	12.16	13.23	14.32	15.43	16.55	17.68	18.82	19.97	21.13	22.30	23.47	24.65	25.84	27.04	28.24
78		6.112	7.028	7.977	8.463	8.956	9.962	10.99	12.04	13.11	14.19	15.29	16.40	17.53	18.66	19.81	20.96	22.13	23.30	24.48	25.66	26.85	28.05
81		6.039	6.946	7.888	8.371	8.859	9.858	10.88	11.92	12.98	14.06	15.15	16.26	17.38	18.51	19.65	20.80	21.96	23.13	24.30	25.48	26.67	27.86
84		5.968	6.867	7.801	8.280	8.765	9.756	10.77	11.87	12.93	14.03	15.12	16.23	17.34	18.46	19.59	20.74	21.89	23.06	24.23	25.41	26.59	27.78
23		9.271	10.35	11.43	11.97	12.50	13.56	14.62	15.68	16.73	17.78	18.82	19.86	20.89	21.92	22.95	23.98	25.00	26.02	27.04	28.06	29.08	30.09
24		9.261	10.34	11.42	11.96	12.49	13.56	14.62	15.67	16.72	17.77	18.81	19.85	20.89	21.92	22.95	23.98	25.00	26.03	27.05	28.06	29.08	30.09
25		9.251	10.33	11.41	11.95	12.48	13.55	14.61	15.67	16.72	17.77	18.81	19.85	20.89	21.92	22.95	23.98	25.00	26.03	27.05	28.07	29.08	30.09
26		9.242	10.32	11.40	11.94	12.47	13.54	14.60	15.66	16.71	17.76	18.81	19.85	20.88	21.92	22.95	23.98	25.00	26.03	27.05	28.07	29.09	30.10
27		9.232	10.32	11.39	11.93	12.47	13.53	14.60	15.65	16.71	17.76	18.80	19.84	20.88	21.92	22.95	23.98	25.00	26.03	27.05	28.07	29.09	30.10
28		9.221	10.31	11.38	11.92	12.46	13.53	14.59	15.65	16.70	17.75	18.80	19.84	20.88	21.91	22.95	23.98	25.00	26.03	27.05	28.07	29.09	30.11
29		9.211	10.30	11.36	11.91	12.45	13.52	14.58	15.64	16.70	17.75	18.79	19.83	20.88	21.91	22.94	23.97	25.00	26.03	27.05	28.07	29.09	30.11
30		9.201	10.29	11.37	11.90	12.44	13.51	14.57	15.63	16.69	17.74	18.79	19.83	20.87	21.91	22.94	23.97	25.00	26.03	27.05	28.07	29.09	30.11
31		9.191	10.28	11.36	11.89	12.43	13.50	14.57	15.63	16.68	17.73	18.78	19.83	20.87	21.91	22.94	23.97	25.00	26.03	27.05	28.07	29.09	30.11
32		9.180	10.27	11.35	11.88	12.42	13.49	14.56	15.62	16.68	17.73	18.78	19.82	20.86	21.90	22.94	23.97	25.00	26.03	27.05	28.07	29.10	30.11
33		9.170	10.26	11.34	11.87	12.41	13.48	14.55	15.61	16.67	17.72	18.77	19.82	20.86	21.90	22.93	23.97	25.00	26.03	27.05	28.07	29.10	30.12
34		9.159	10.25	11.33	11.87	12.41	13.48	14.54	15.60	16.66	17.72	18.77	19.81	20.86	21.90	22.93	23.97	25.00	26.02	27.05	28.08	29.10	30.12
35		9.149	10.24	11.32	11.86	12.39	13.47	14.53	15.60	16.66	17.71	18.76	19.81	20.85	21.89	22.93	23.96	24.99	26.02	27.05	28.07	29.10	30.12
36		9.138	10.23	11.31	11.85	12.39	13.46	14.53	15.59	16.65	17.70	18.75	19.80	20.85	21.89	22.93	23.96	24.99	26.02	27.05	28.07	29.10	30.12
37		9.127	10.21	11.30	11.84	12.38	13.45	14.52	15.58	16.64	17.70	18.75	19.80	20.83	21.88	22.92	23.96	24.99	26.02	27.05	28.07	29.10	30.12
38		9.117	10.20	11.29	11.83	12.37	13.44	14.51	15.57	16.63	17.69	18.74	19.79	20.84	21.88	22.92	23.95	24.99	26.02	27.05	28.07	29.10	30.12
39		9.106	10.19	11.28	11.82	12.36	13.43	14.50	15.56	16.63	17.68	18.74	19.79	20.83	21.88	22.91	23.95	24.99	26.02	27.05	28.07	29.10	30.12
40		9.095	10.18	11.27	11.81	12.35	13.42	14.49	15.56	16.62	17.68	18.73	19.78	20.83	21.87	22.91	23.95	24.98	26.01	27.04	28.07	29.10	30.12
42		9.074	10.16	11.25	11.79	12.33	13.40	14.47	15.54	16.60	17.66	18.72	19.77	20.82	21.86	22.90	23.94	24.98	26.01	27.04	28.07	29.10	30.12
44		9.062	10.14	11.22	11.77	12.31	13.38	14.45	15.52	16.59	17.65	18.70	19.75	20.81	21.85	22.89	23.93	24.97	26.00	27.04	28.07	29.09	30.12
46		9.050	10.12	11.20	11.74	12.28	13.36	14.43	15.50	16.57	17.63	18.69	19.74	20.80	21.84	22.88	23.92	24.96	26.00	27.03	28.06	29.09	30.12
48		9.008	10.10	11.18	11.72	12.26	13.35	14.42	15.49	16.55	17.61	18.67	19.73	20.78	21.83	22.87	23.92	24.95	25.99	27.03	28.06	29.09	30.12
50		8.986	10.07	11.16	11.70	12.24	13.33	14.40	15.47	16.54	17.60	18.66	19.71	20.77	21.82	22.86	23.91	24.95	25.98	27.02	28.05	29.08	30.11
52		8.963	10.05	11.14	11.68	12.22	13.31	14.38	15.45	16.52	17.58	18.64	19.70	20.75	21.81	22.85	23.90	24.94	25.98	27.01	28.05	29.08	30.11
54		8.941	10.03	11.12	11.66	12.20	13.29	14.36	15.43	16.50	17.56	18.63	19.68	20.74	21.80	22.84	23.89	24.93	25.97	27.01	28.04	29.07	30.11
56		8.919	10.01	11.09	11.64	12.18	13.26	14.34	15.41	16.48	17.55	18.61	19.67	20.73	21.78	22.83	23.87	24.92	25.96	27.00	28.03	29.07	30.10
58		8.896	9.985	11.07	11.61	12.16	13.24	14.32	15.39	16.46	17.53	18.59	19.65	20.71	21.76	22.82	23.86	24.90	25.95	26.99	28.03	29.06	30.10
60		8.874	9.963	11.05	11.59	12.14	13.22	14.30	15.37	16.44	17.51	18.57	19.64	20.70	21.75	22.80	23.85	24.90	25.94	26.98	28.02	29.05	30.09
63		8.841	9.929	11.02	11.56	12.10	13.18	14.26	15.34	16.41	17.48	18.55	19.62	20.67	21.73	22.78	23.83	24.88	25.92	26.96	28.01	29.04	30.08
66		8.807	9.895	10.98	11.52	12.07	13.15	14.23	15.31	16.38	17.45	18.52	19.58	20.65	21.70	22.76	23.81	24.86	25.91	26.95	27.99	29.03	30.07
69		8.773	9.861	10.95	11.49	12.03	13.12	14.20	15.28	16.35	17.42	18.49	19.56	20.62	21.68	22.74	23.79	24.84	25.89	26.93	28.00	29.02	30.06
72		8.740	9.827	10.91	11.45	12.00	13.09	14.17	15.25	16.32	17.39	18.46	19.53	20.60	21.66	22.71	23.77	24.82	25.87	26.91	27.96	29.	

TABLE 8.- VALUES OF AVERAGE STRESS AT MAXIMUM LOAD FOR COMPARATIVE
HAT- AND Z-STIFFENED SPECIMENS¹

$\frac{L}{p}$	Average stress, $\bar{\sigma}_f$, ksi			
	$\frac{b_S}{t_S} = 25$		$\frac{b_S}{t_S} = 35$	
	Hat-stiffened panel	Z-stiffened panel	Hat-stiffened panel	Z-stiffened panel
(a) As panels subjected to simple compression				
20	39.1	39.5	30.1	28.6
40	39.3	38.5	29.7	27.8
70	37.8	33.4	29.6	26.7
(b) As the compression covers of box beams subjected to bending plus compression				
70	38.6	36.3	28.0	28.8
(c) As the compression covers of box beams subjected to bending plus vertical shear plus compression				
70	40.3	42.2	28.6	30.4

¹All comparative specimens were constructed from the same sheets of bare 24S-T3 aluminum alloy. The compressive yield stress for these sheets was found to vary from 44.0 ksi to 46.0 ksi.

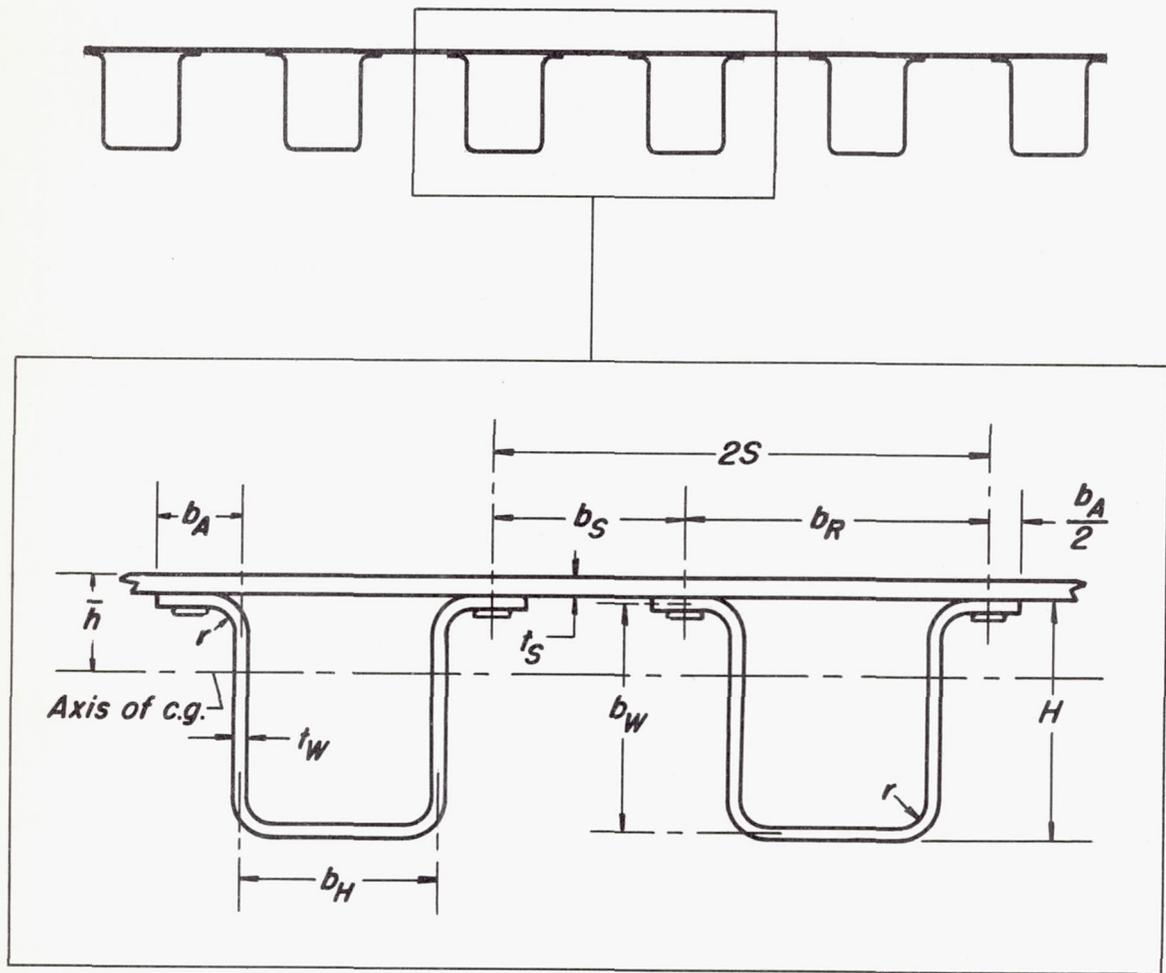

Figure 1.—Symbols for panel dimensions.

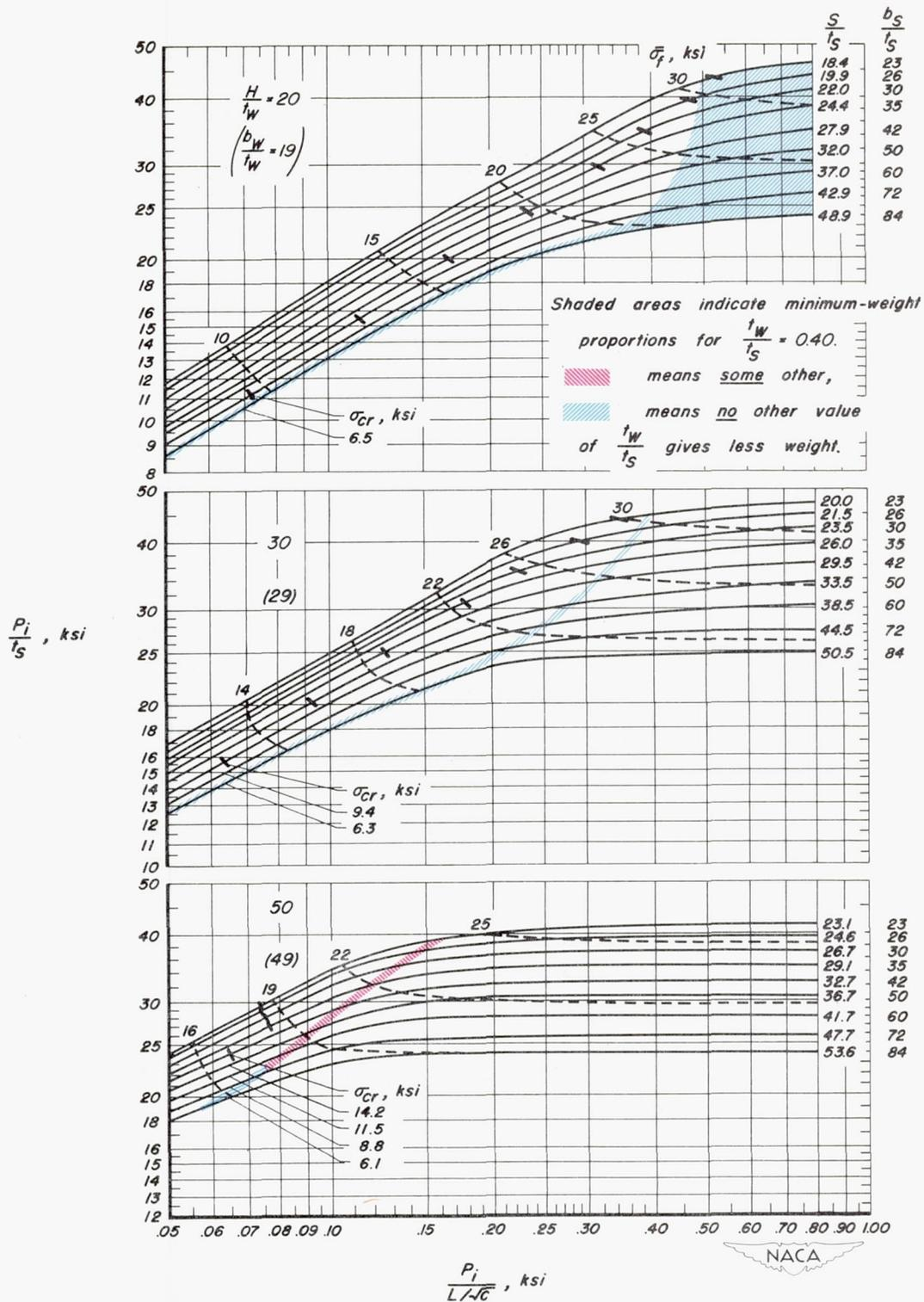

Figure 2.—Direct-reading design chart for flat compression panels of 24S-T3 aluminum alloy with formed hat-section stiffeners, $\frac{t_w}{t_s} = 0.40$.

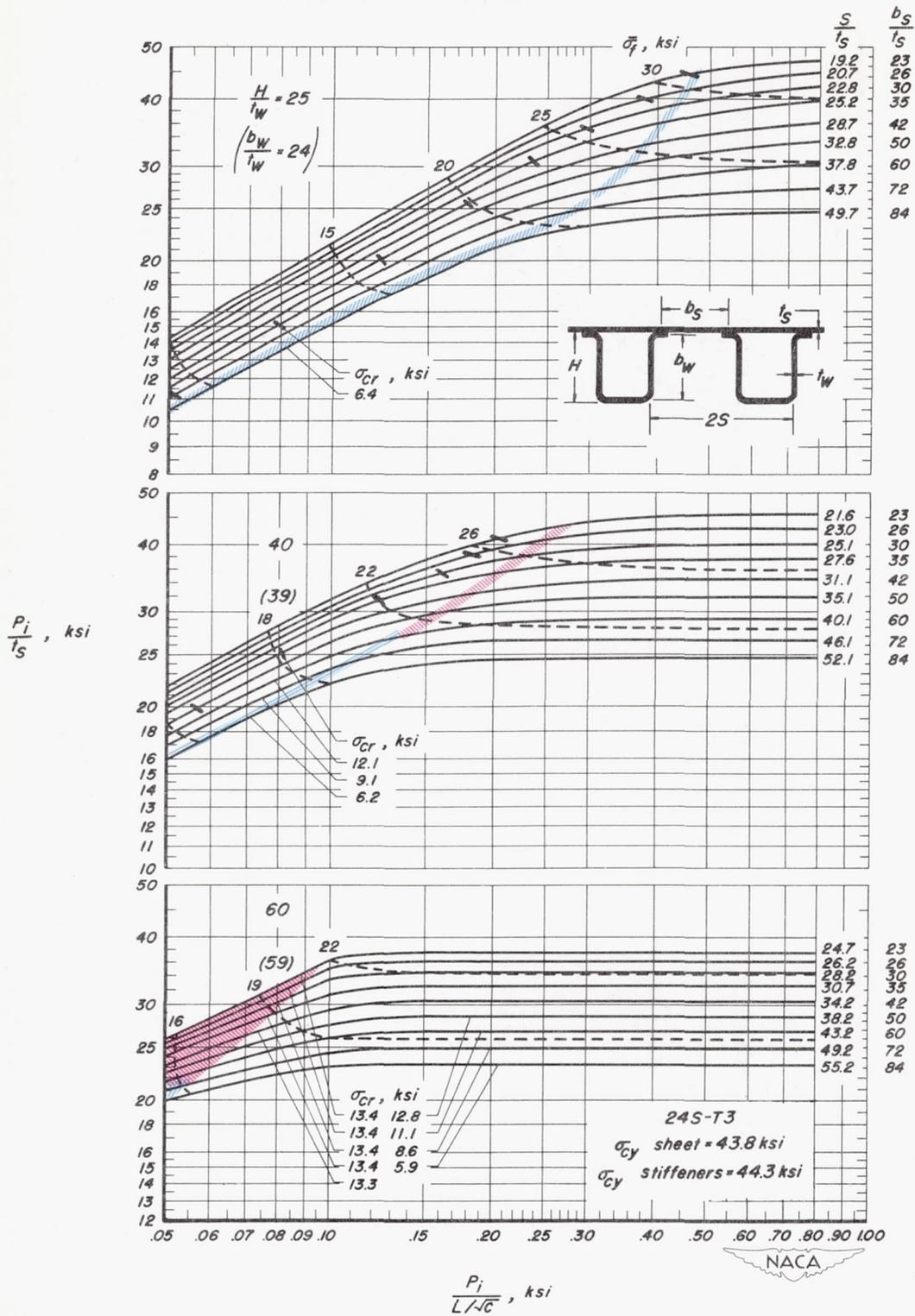

Figure 2.- Concluded

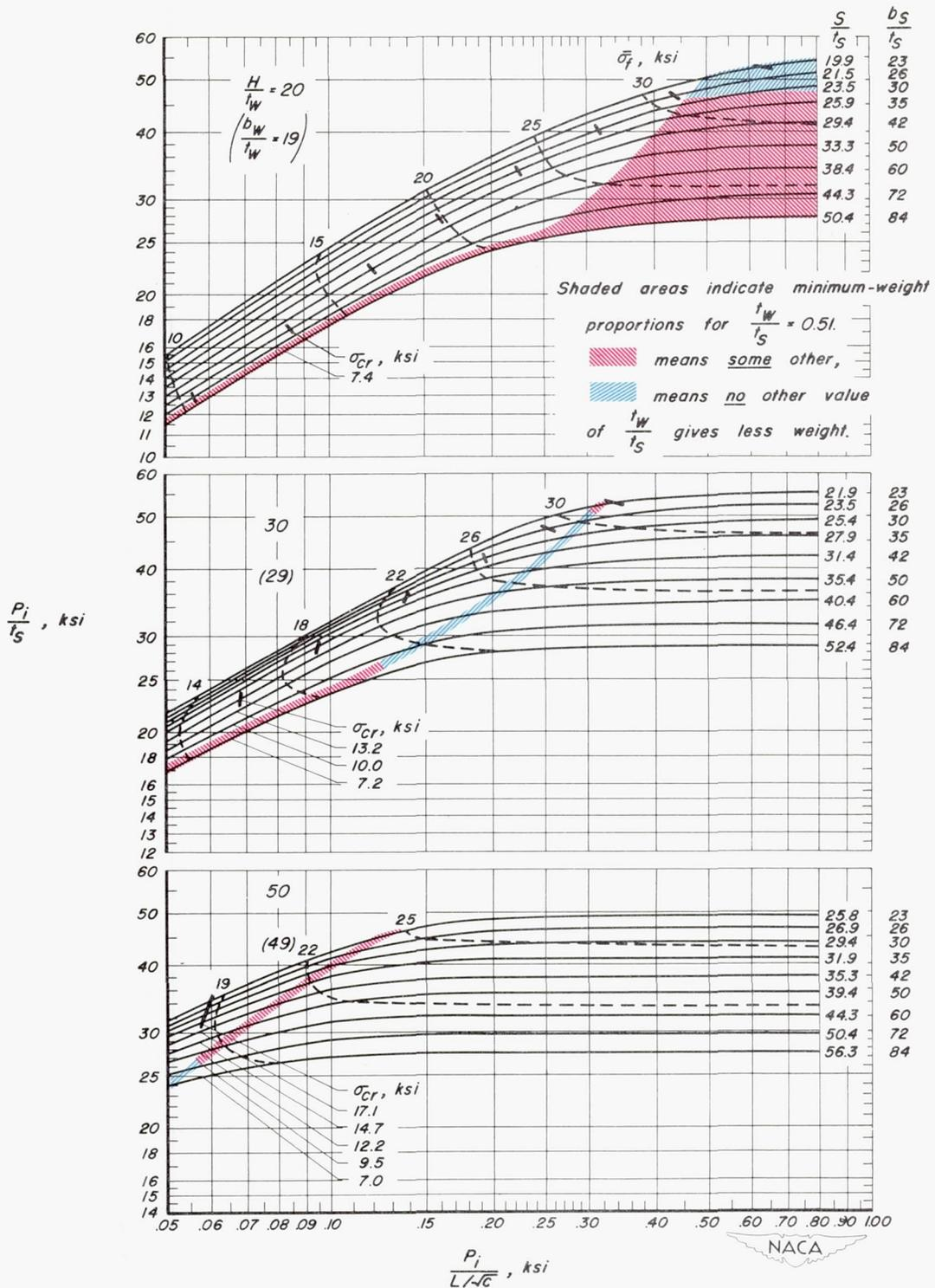

Figure 3.—Direct-reading design chart for flat compression panels of 24S-T3 aluminum alloy with formed hat-section stiffeners. $\frac{t_w}{t_s} = 0.51$.

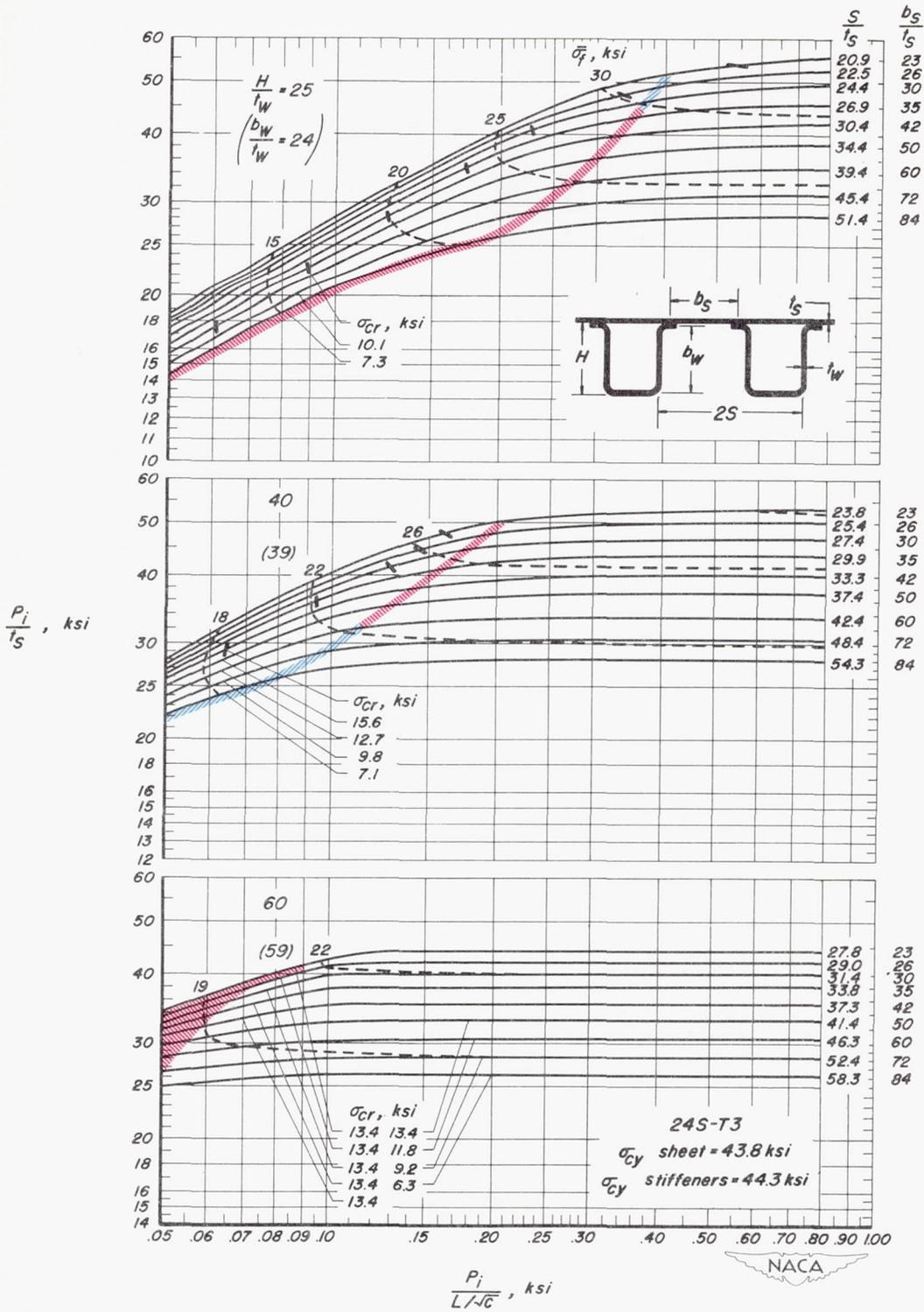

Figure 3—Concluded

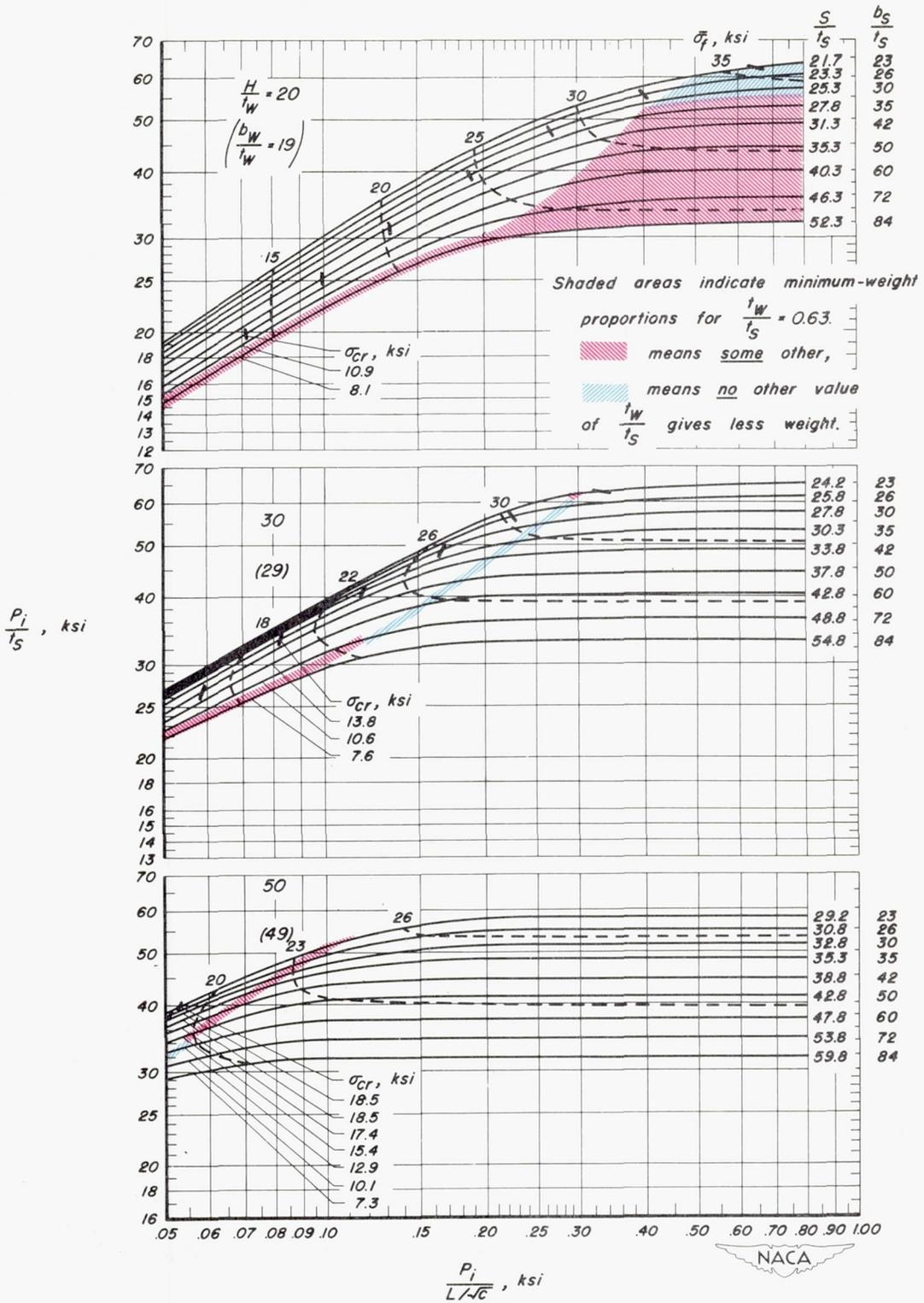

Figure 4.—Direct-reading design chart for flat compression panels of 24S-T3 aluminum alloy with formed hat-section stiffeners. $\frac{t_W}{t_S} = 0.63$.

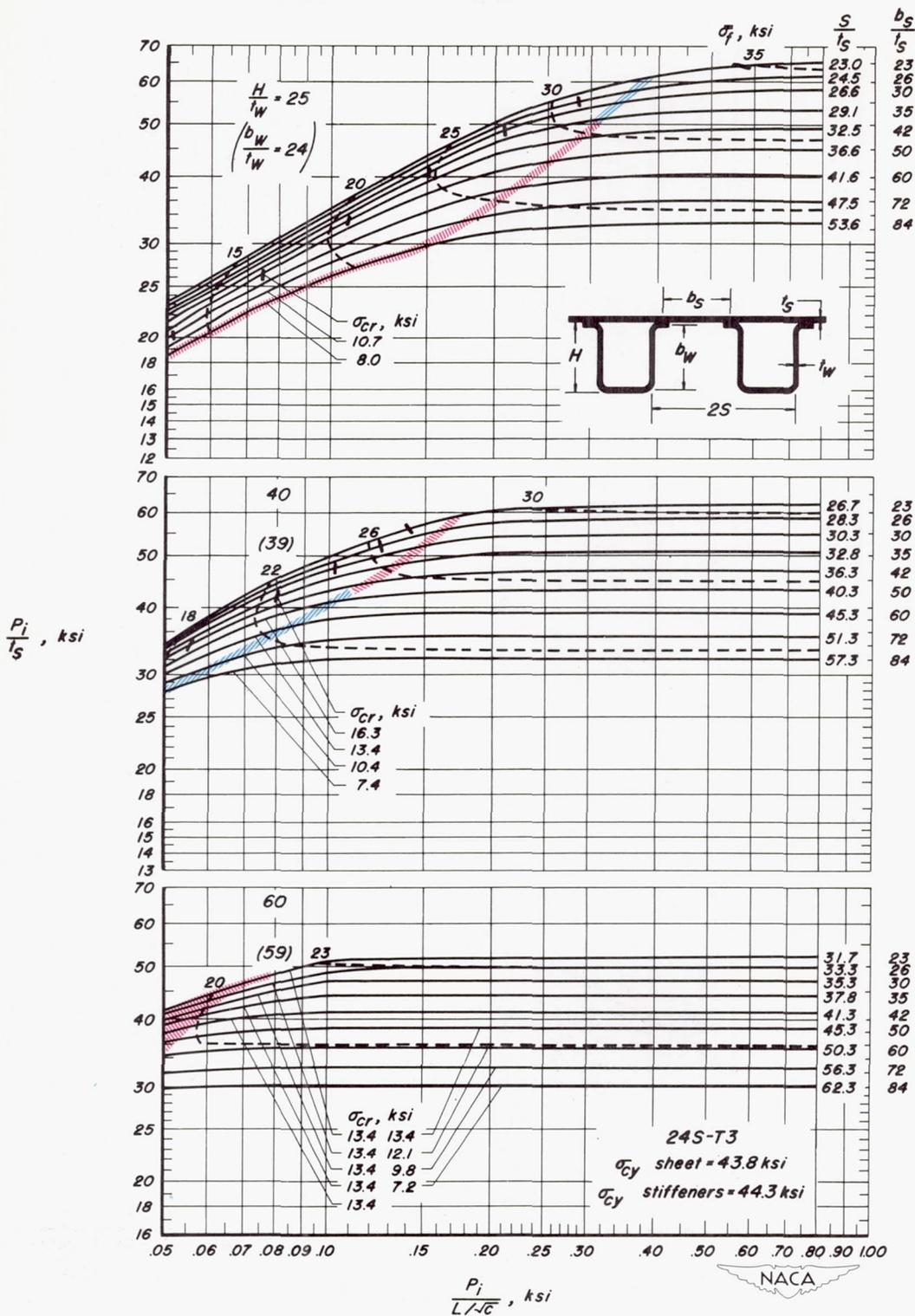

Figure 4.- Concluded

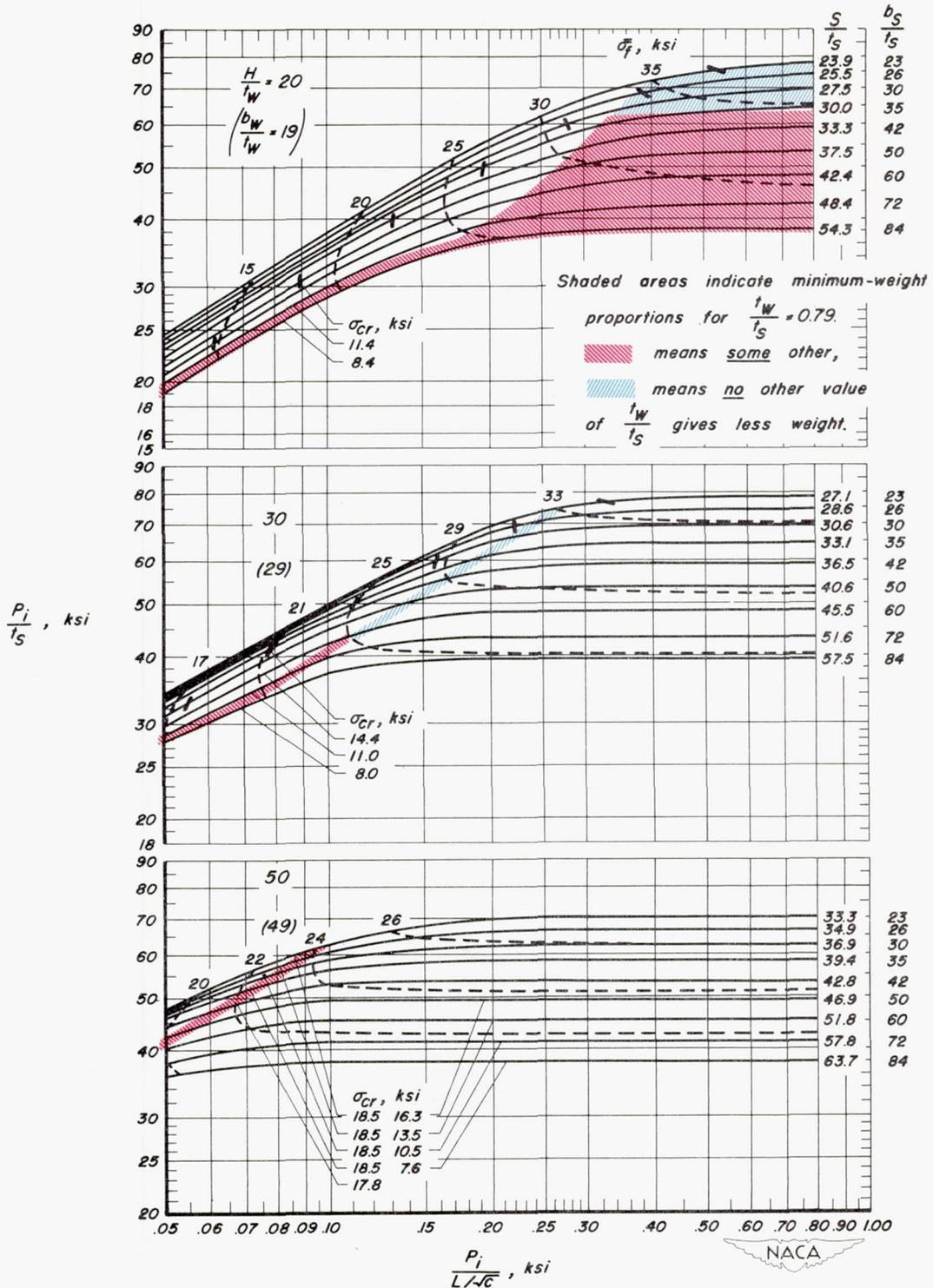

Figure 5.—Direct-reading design chart for flat compression panels of 24S-T3 aluminum alloy with formed hat-section stiffeners. $t_w/t_s = 0.79$.

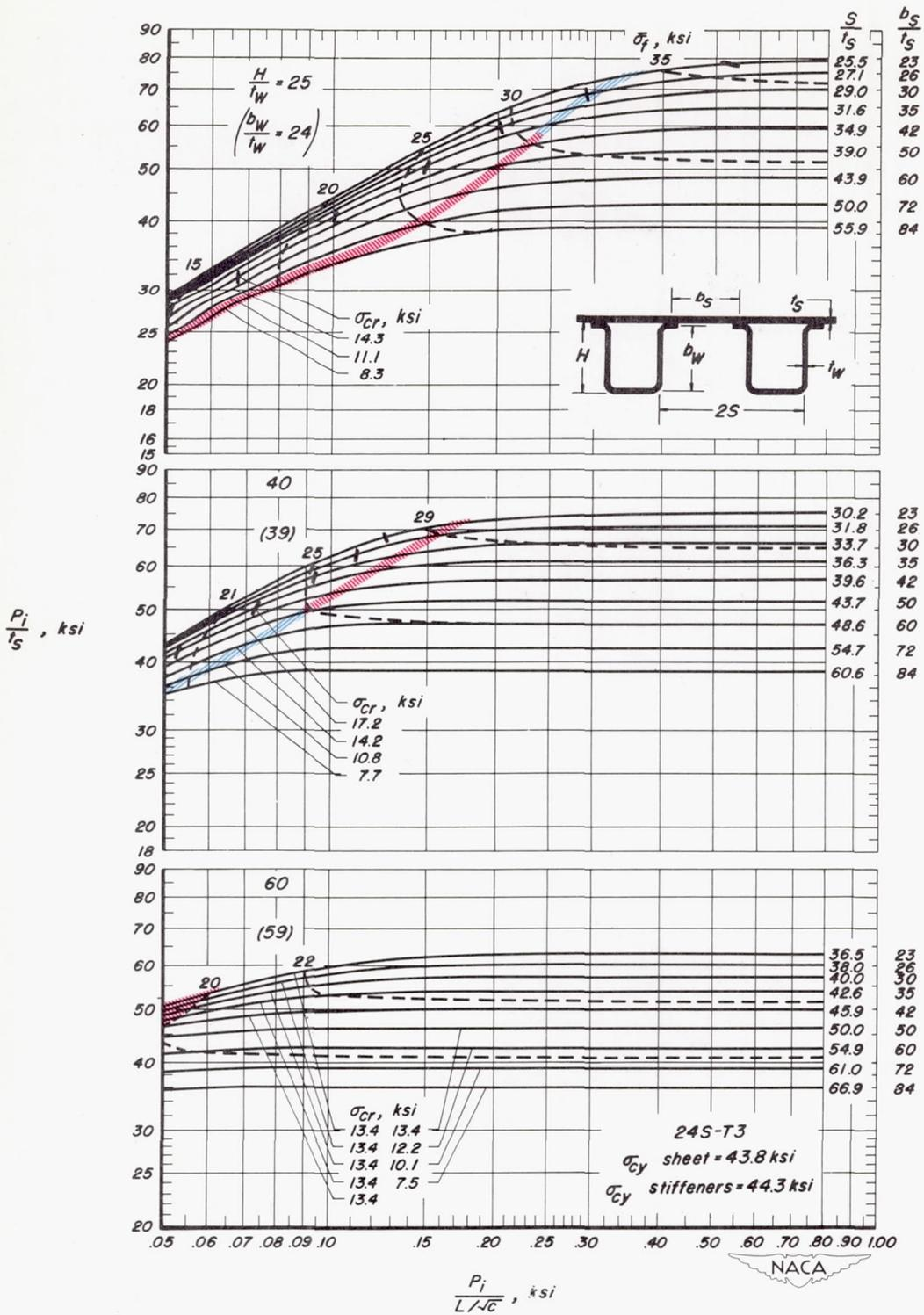

Figure 5.— Concluded

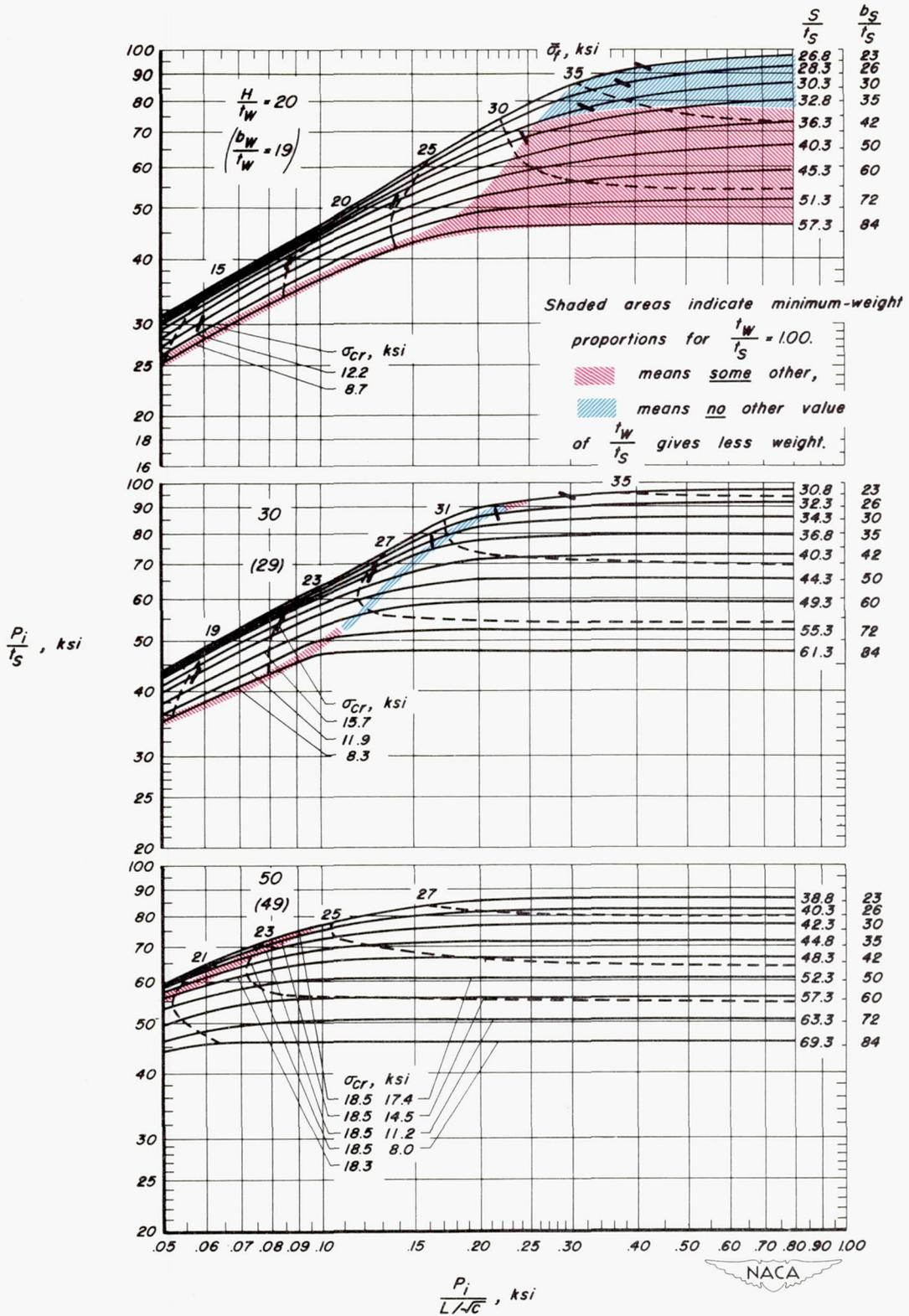

Figure 6.—Direct-reading design chart for flat compression panels of 24S-T3 aluminum alloy with formed hat-section stiffeners. $\frac{t_w}{t_s} = 1.00$.

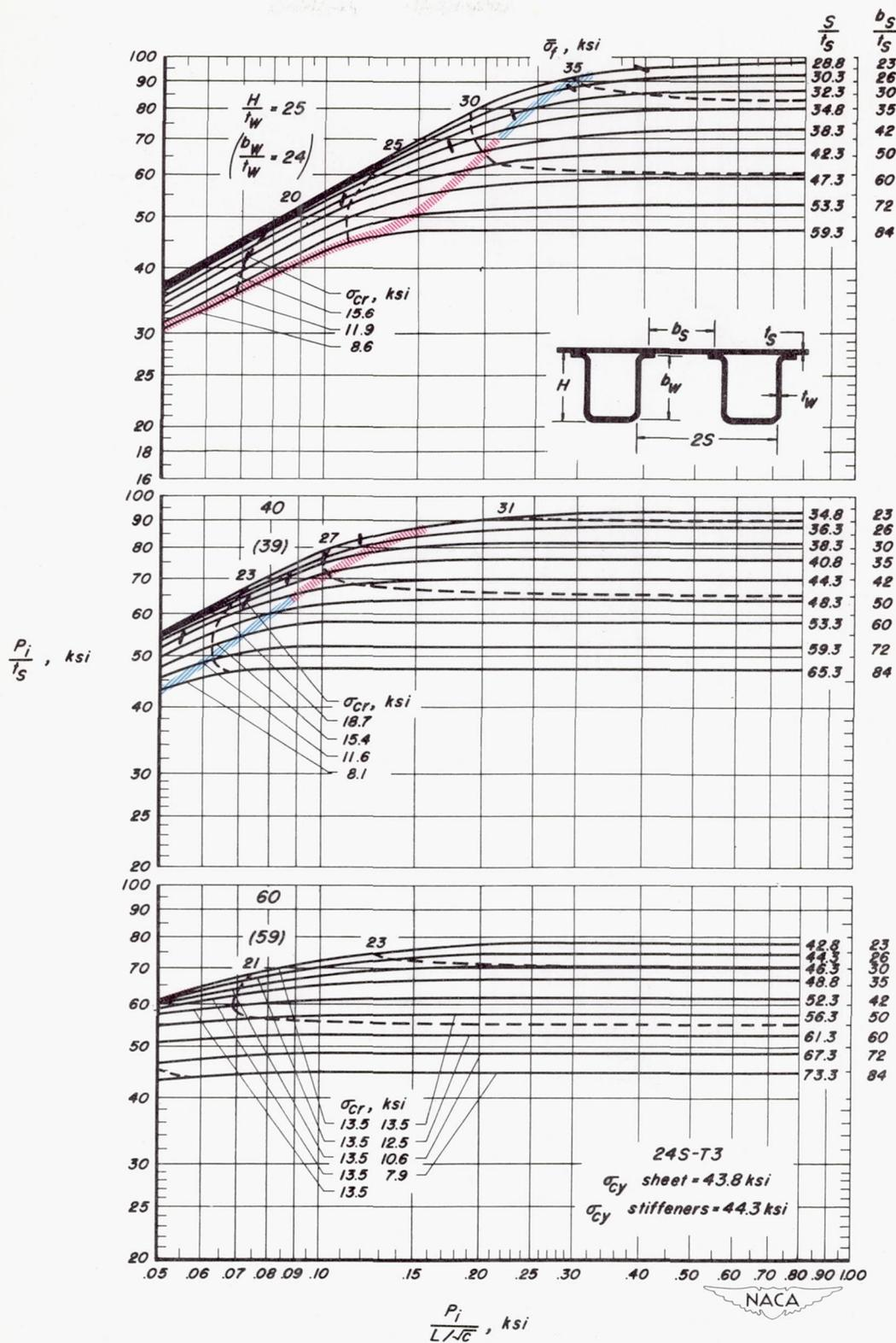

Figure 6.—Concluded

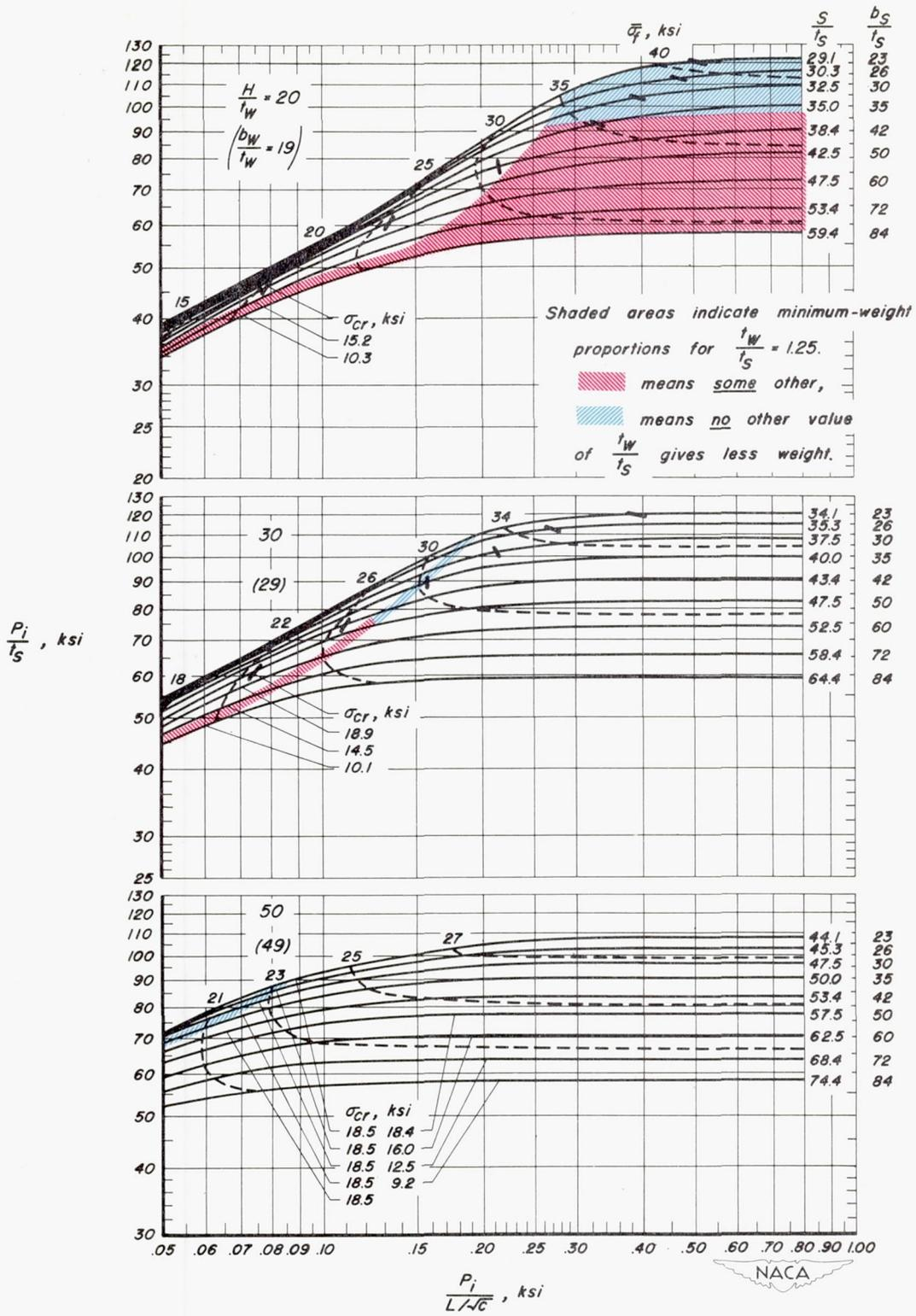

Figure 7.—Direct-reading design chart for flat compression panels of 24S-T3 aluminum alloy with formed hat-section stiffeners. $\frac{t_w}{t_s} = 1.25$.



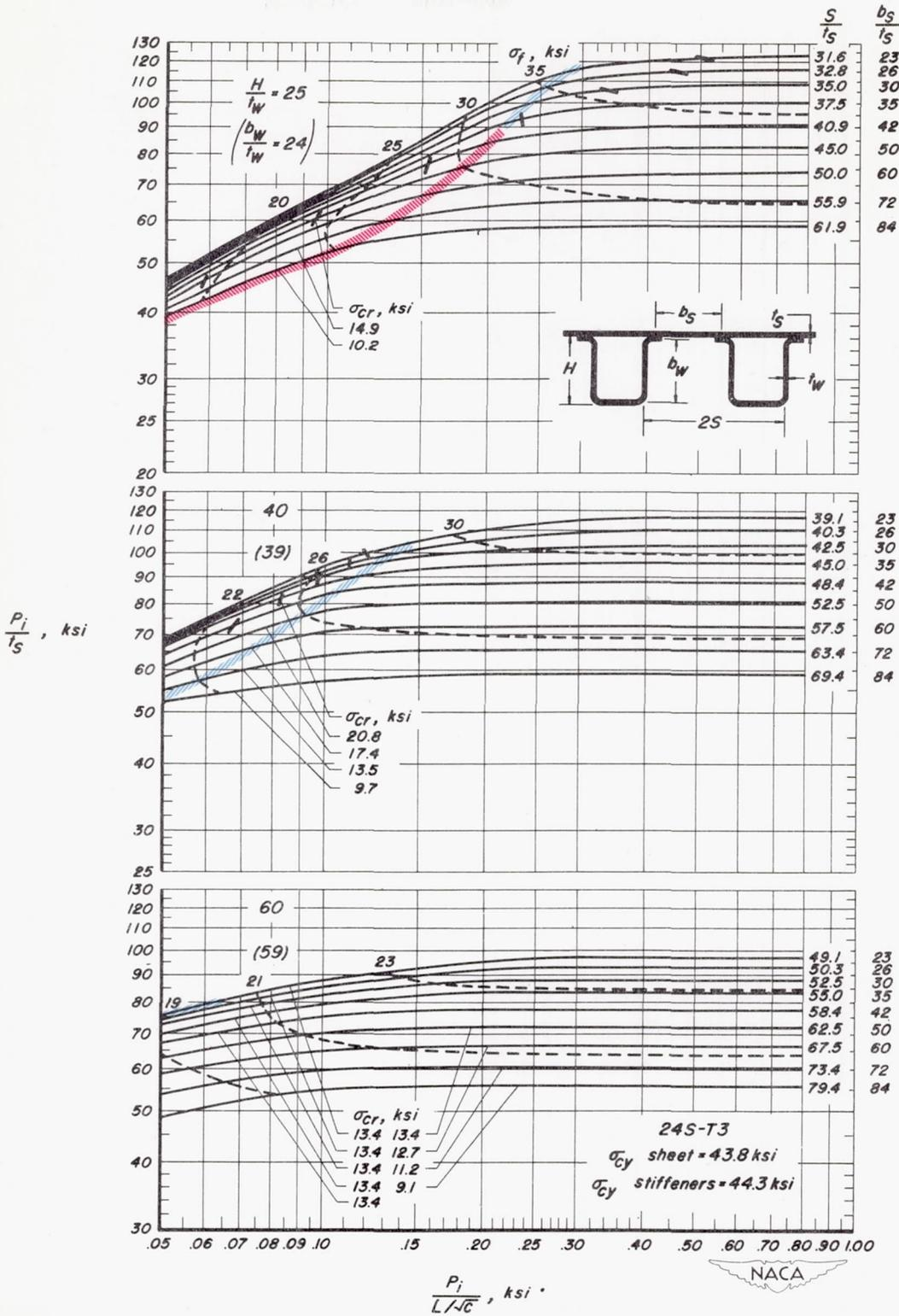

Figure 7. - Concluded

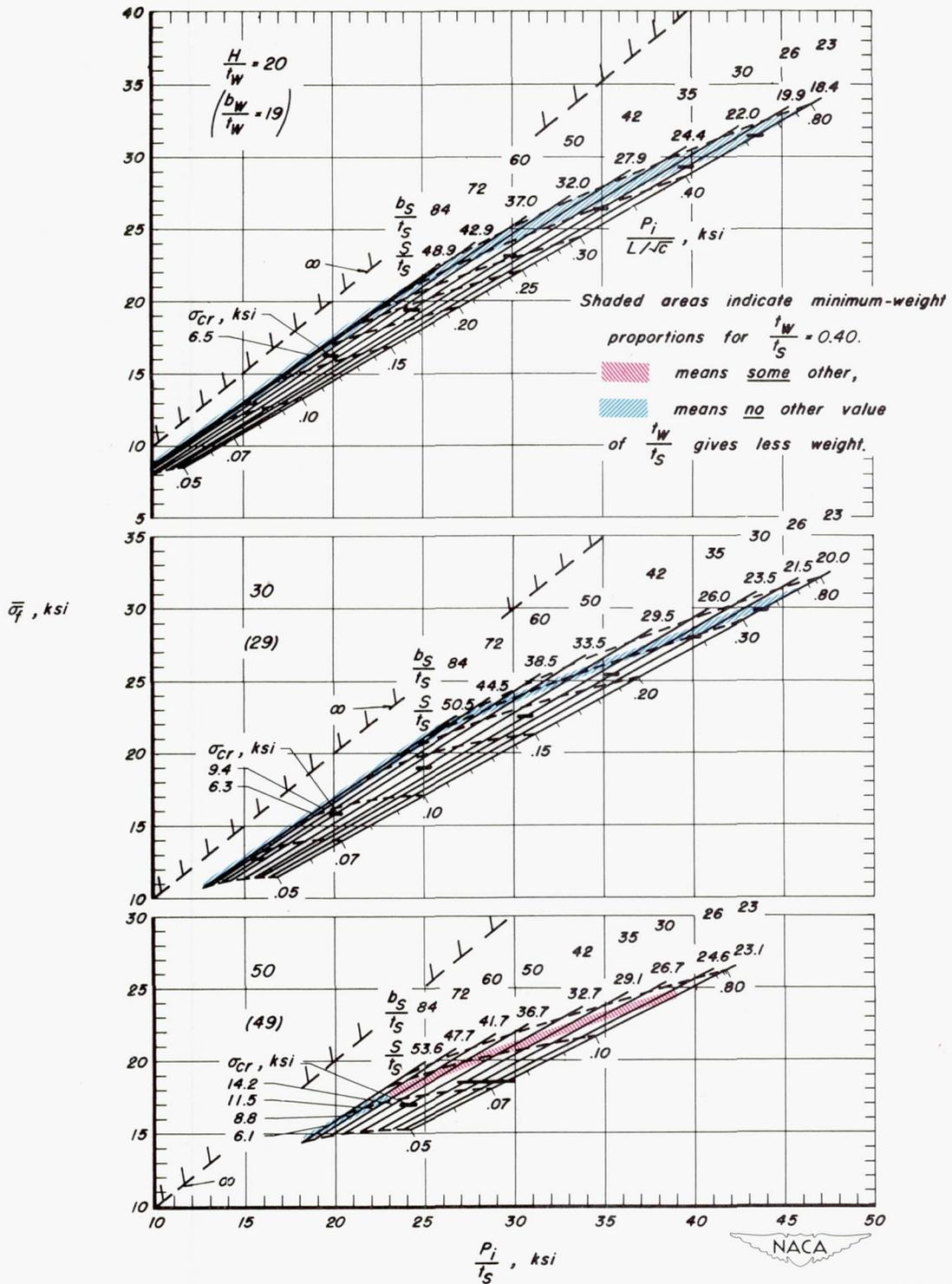

Figure 8.—Direct-reading design chart (alternate form) for flat compression panels of 24S-T3 aluminum alloy with formed hat-section stiffeners, $\frac{t_w}{t_s} = 0.40$.



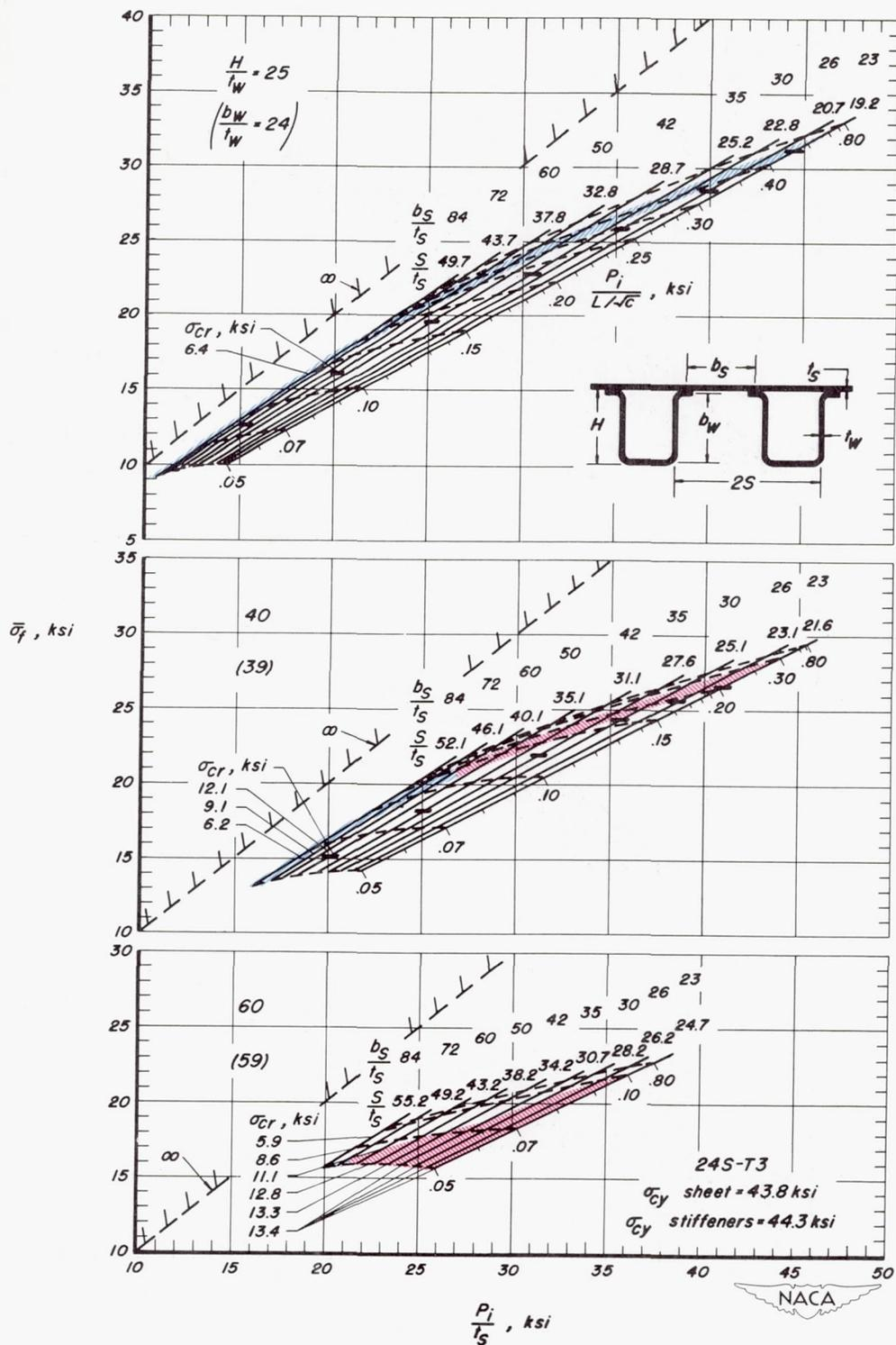

Figure 8.— Concluded

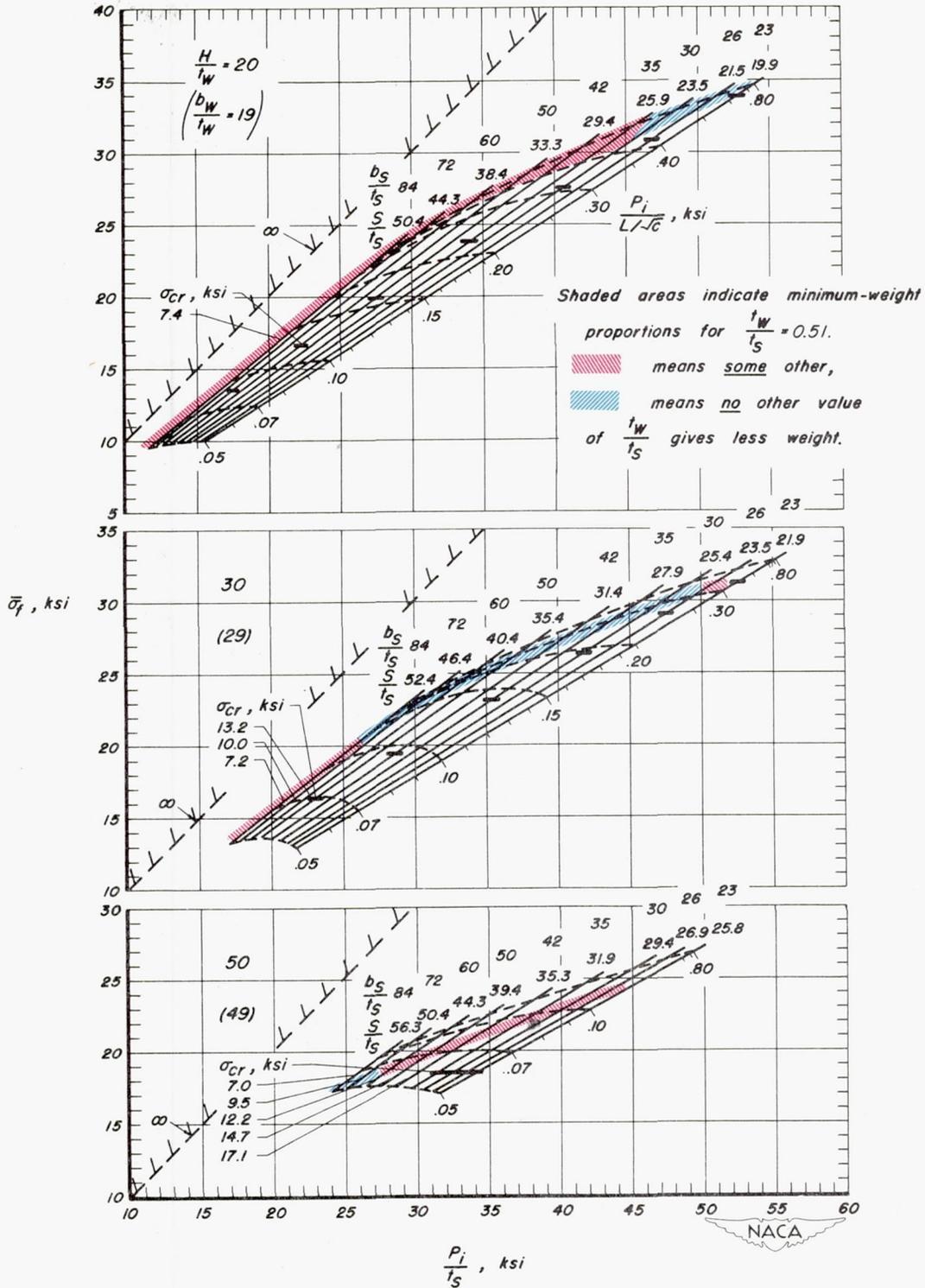

Figure 9.—Direct-reading design chart (alternate form) for flat compression panels of 24S-T3 aluminum alloy with formed hat-section stiffeners. $\frac{t_w}{t_s} = 0.51$



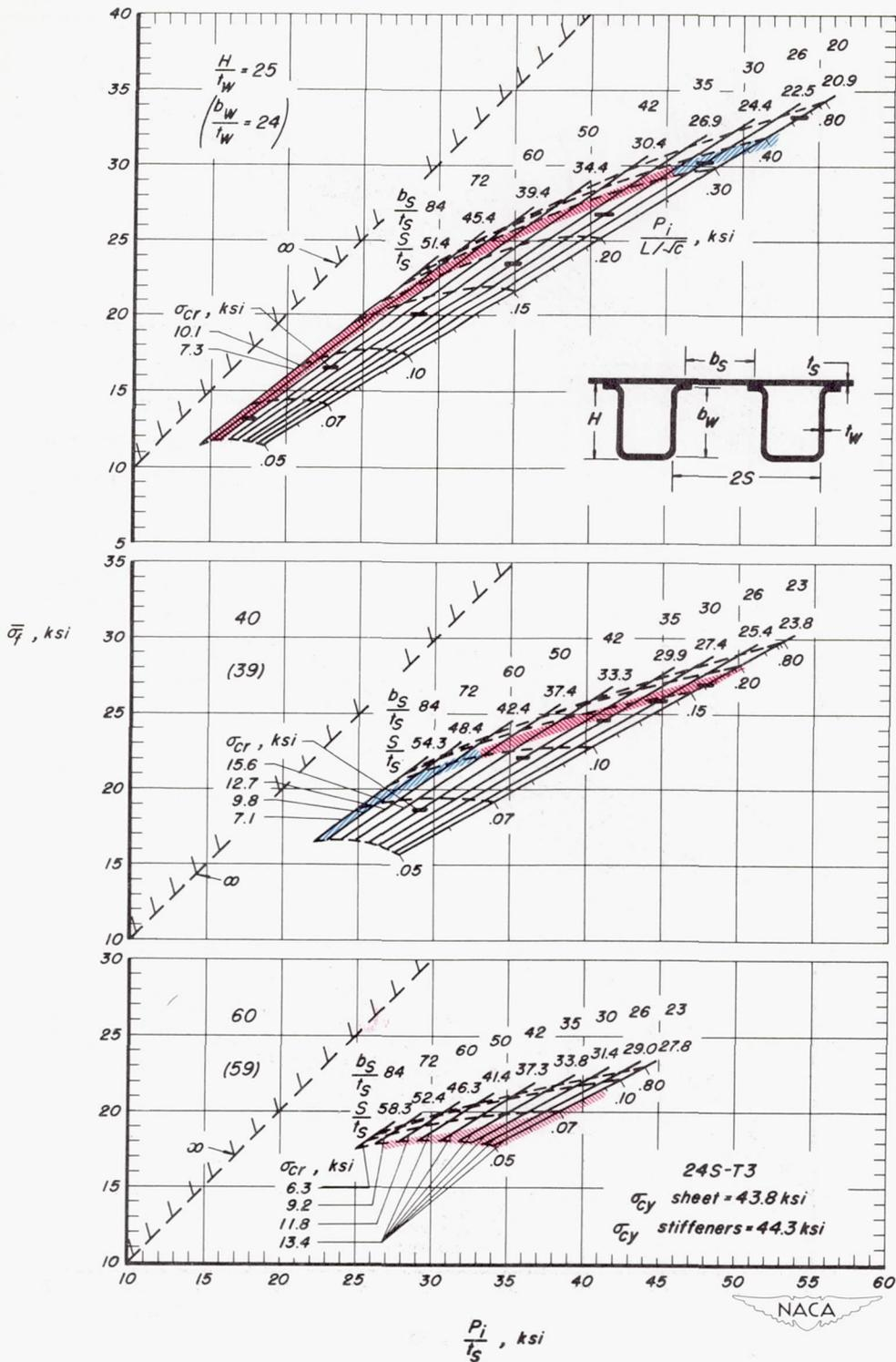

Figure 9.— Concluded

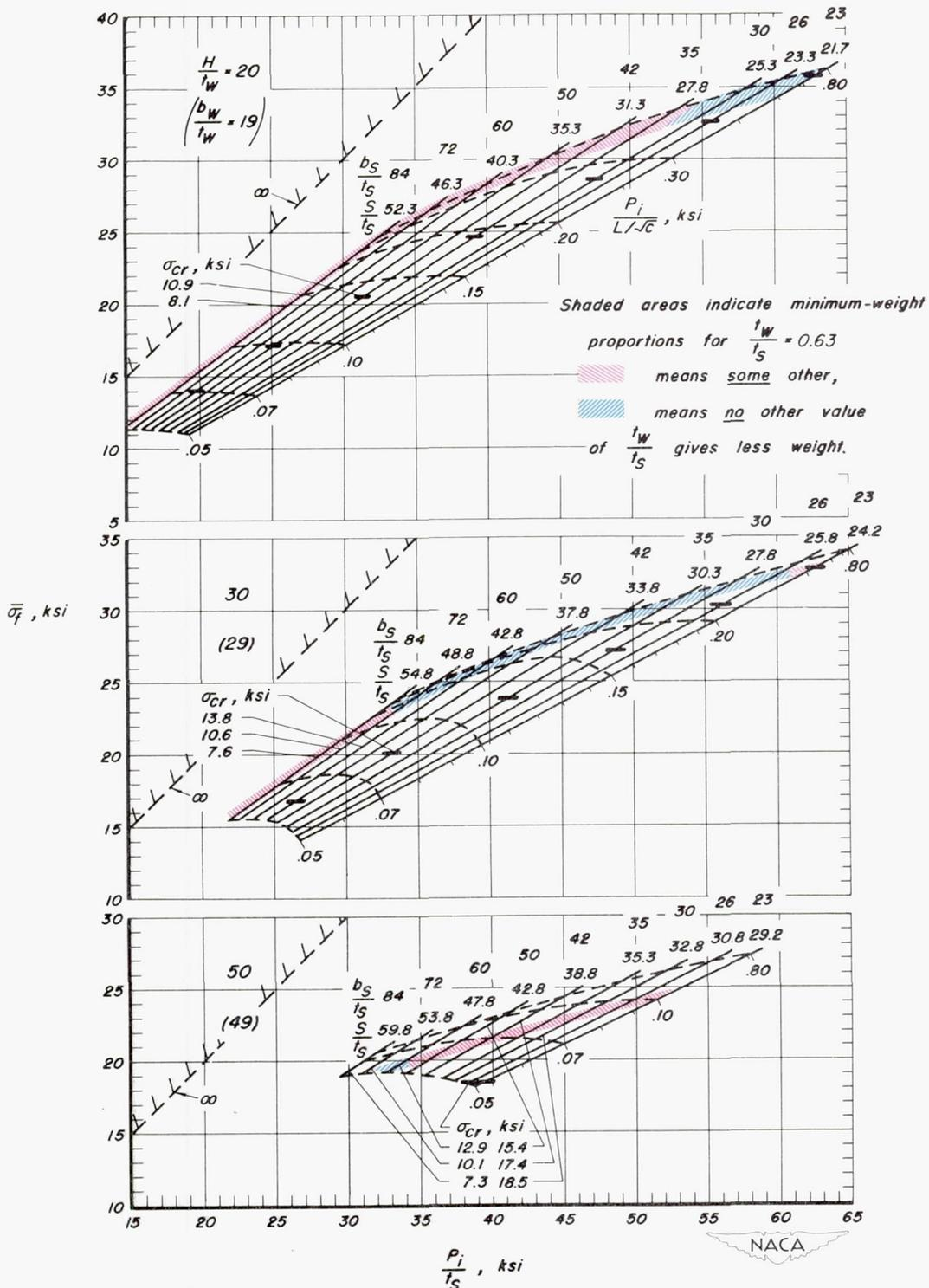

Figure 10.—Direct-reading design chart (alternate form) for flat compression panels of 24S-T3 aluminum alloy with formed hat-section stiffeners. $\frac{t_w}{I_S} = 0.63$.

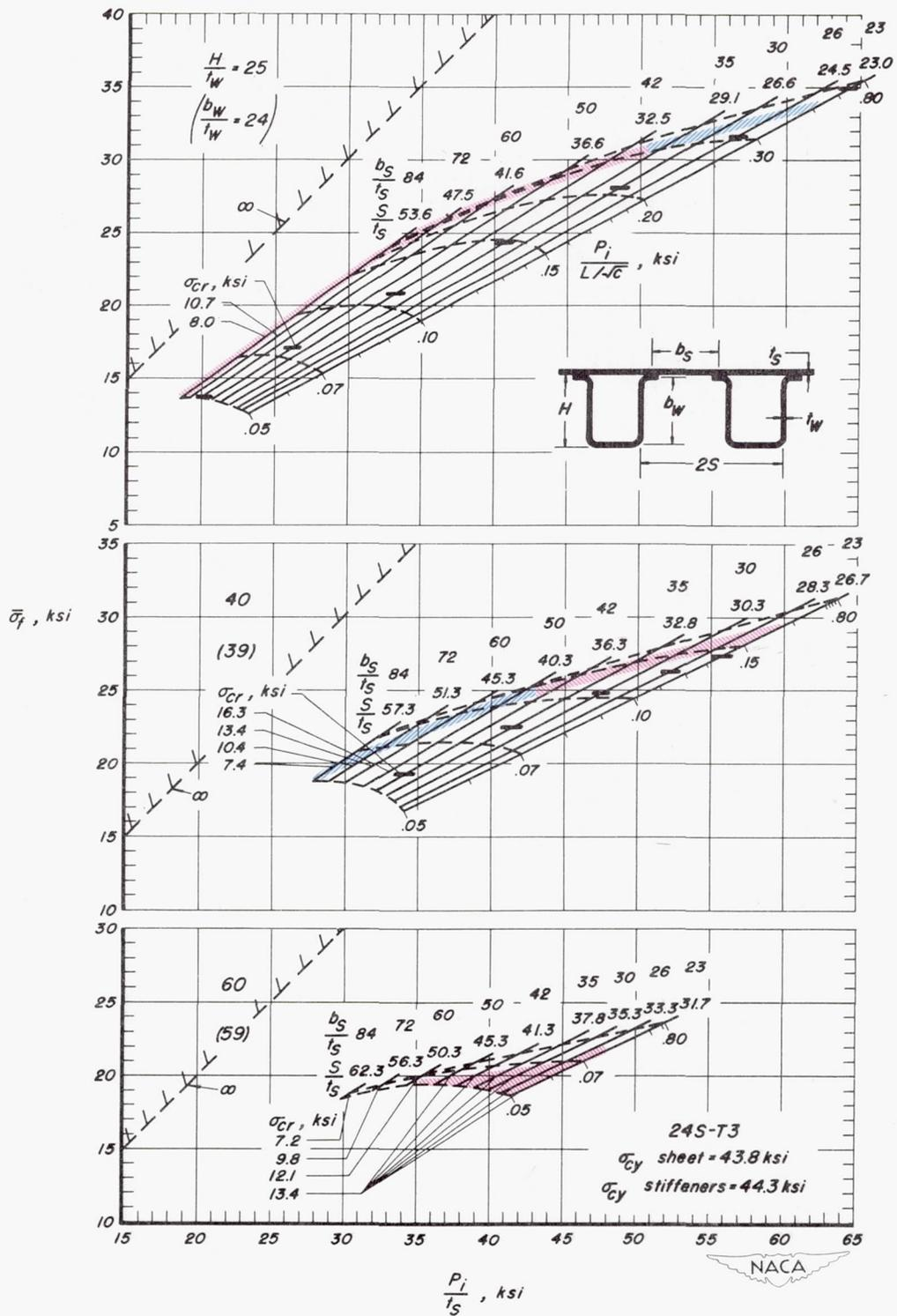

Figure 10.- Concluded

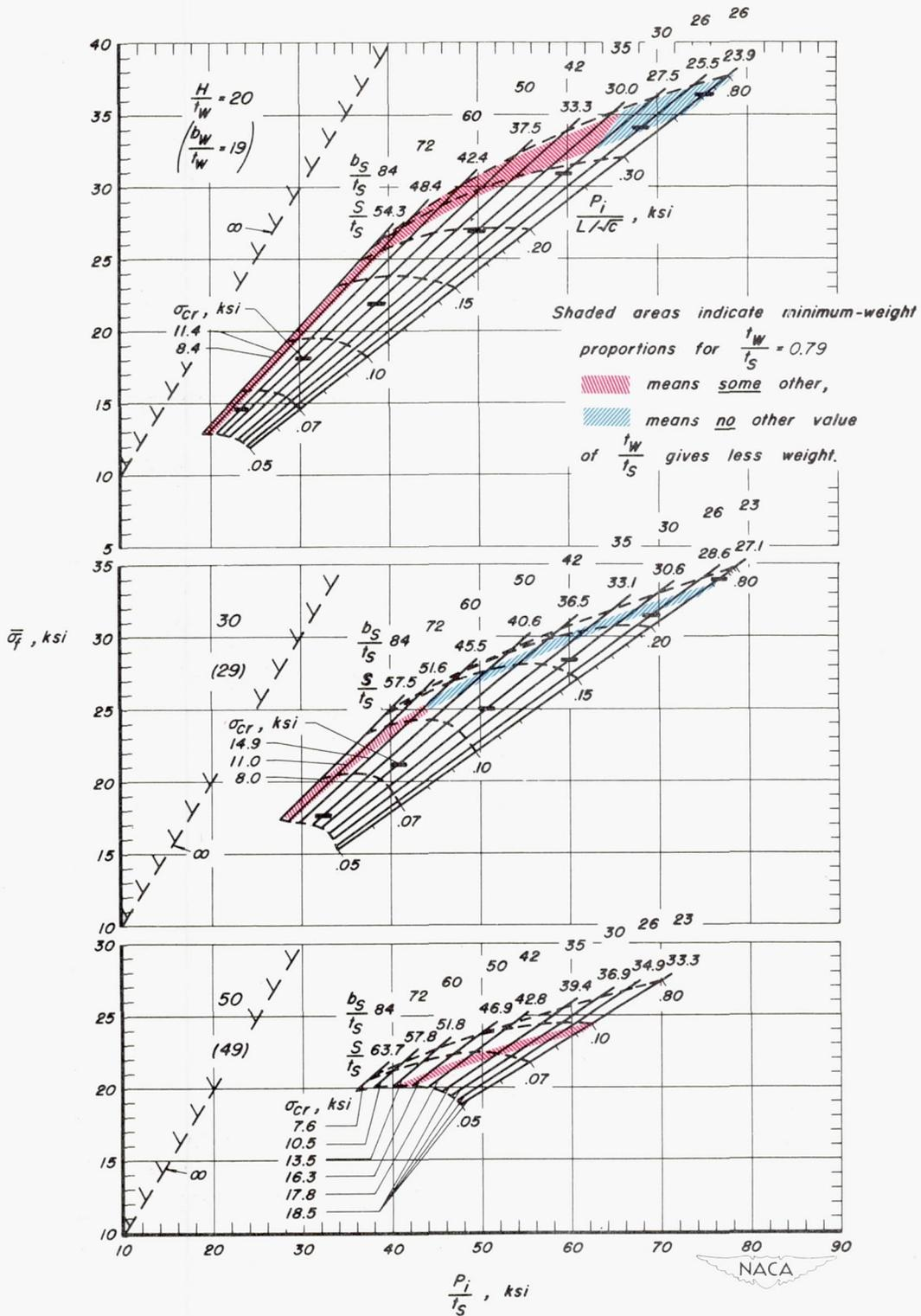

Figure 11.—Direct-reading design chart (alternate form) for flat compression panels of 24S-T3 aluminum alloy with formed hat-section stiffeners. $\frac{t_w}{I_s} = 0.79$.

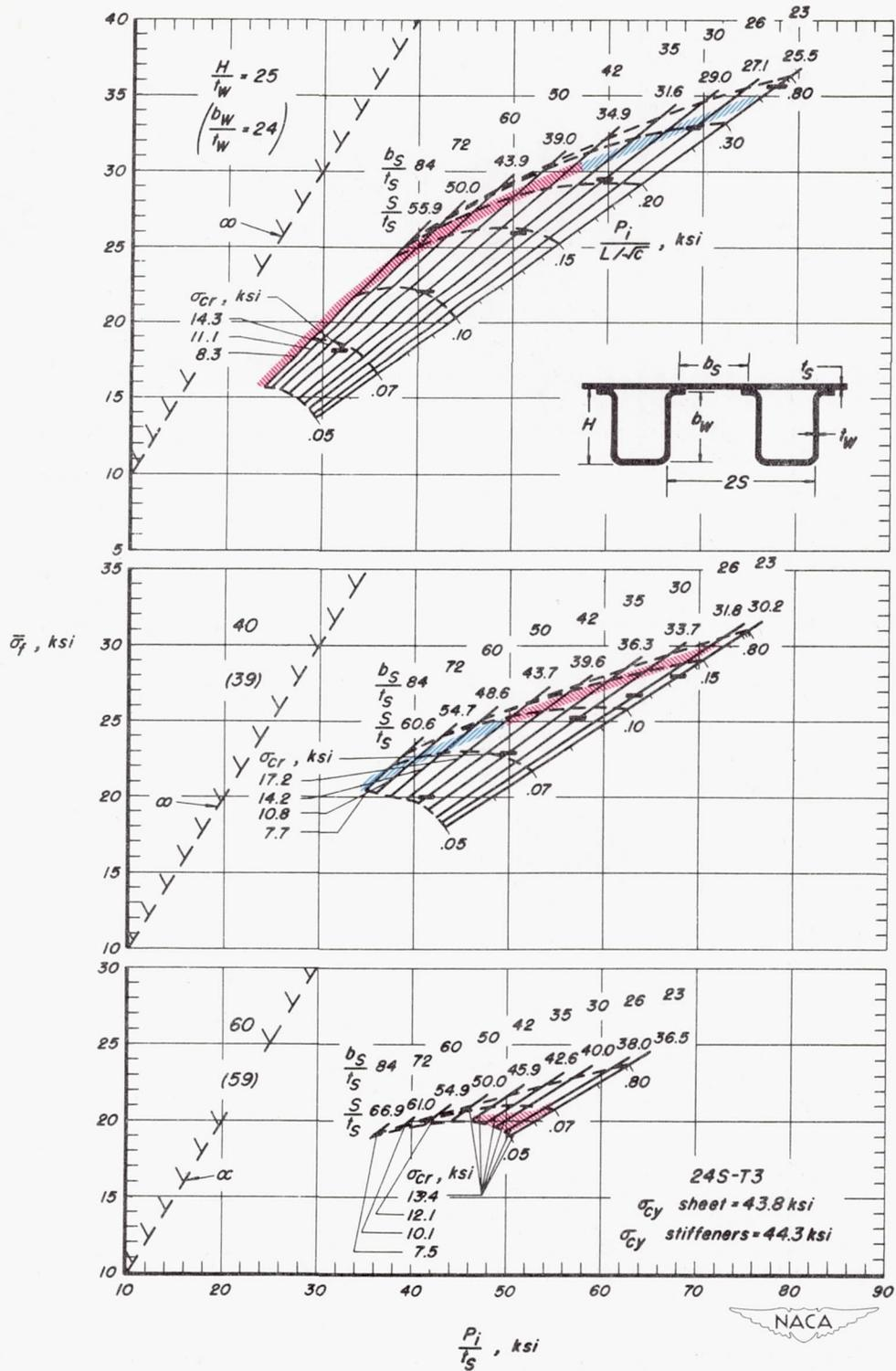

Figure 11.— Concluded

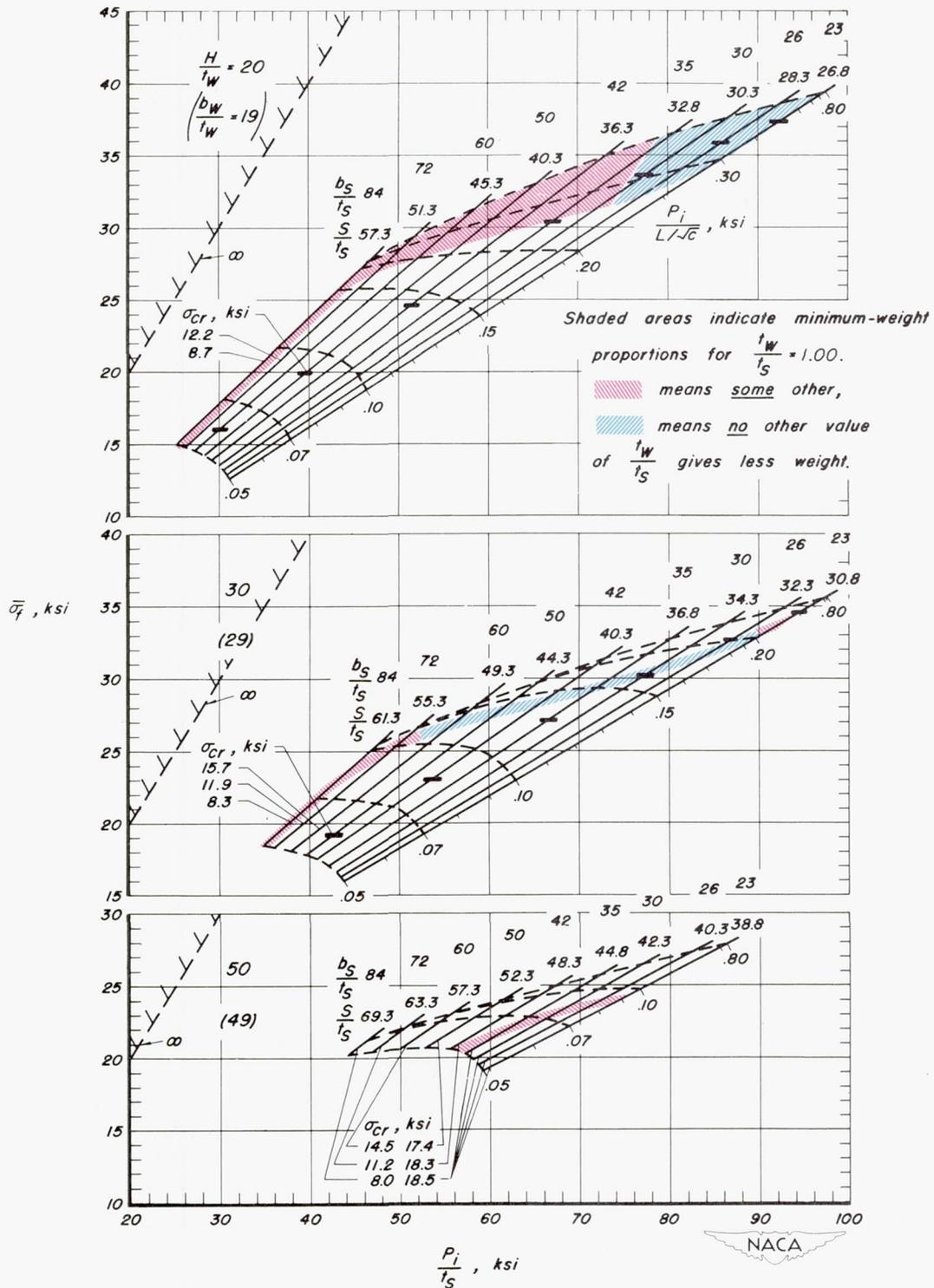

Figure 12.—Direct-reading design chart (alternate form) for flat compression panels of 24S-T3 aluminum alloy with formed hat-section stiffeners. $\frac{t_w}{t_s} = 1.00$.

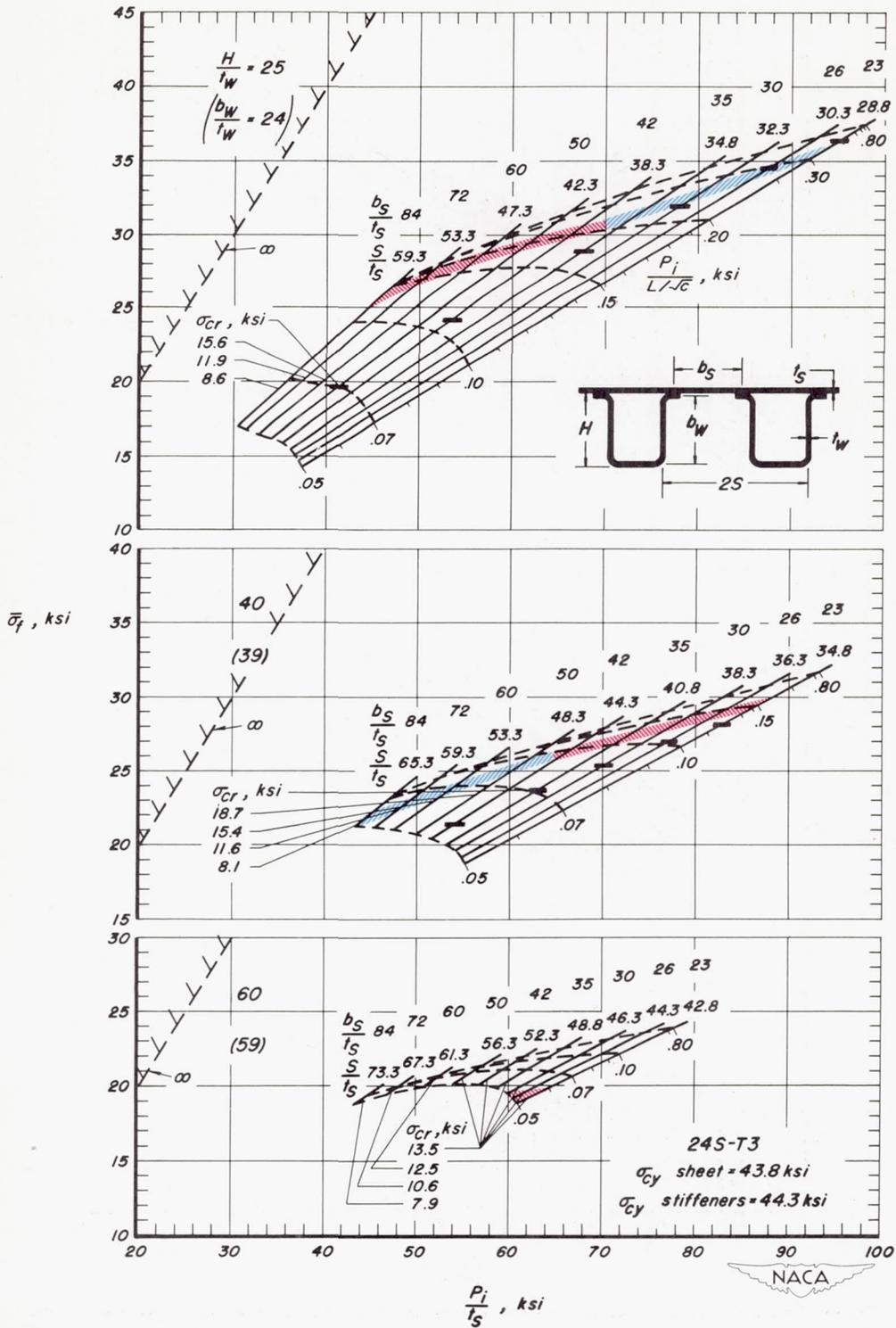

Figure 12.— Concluded

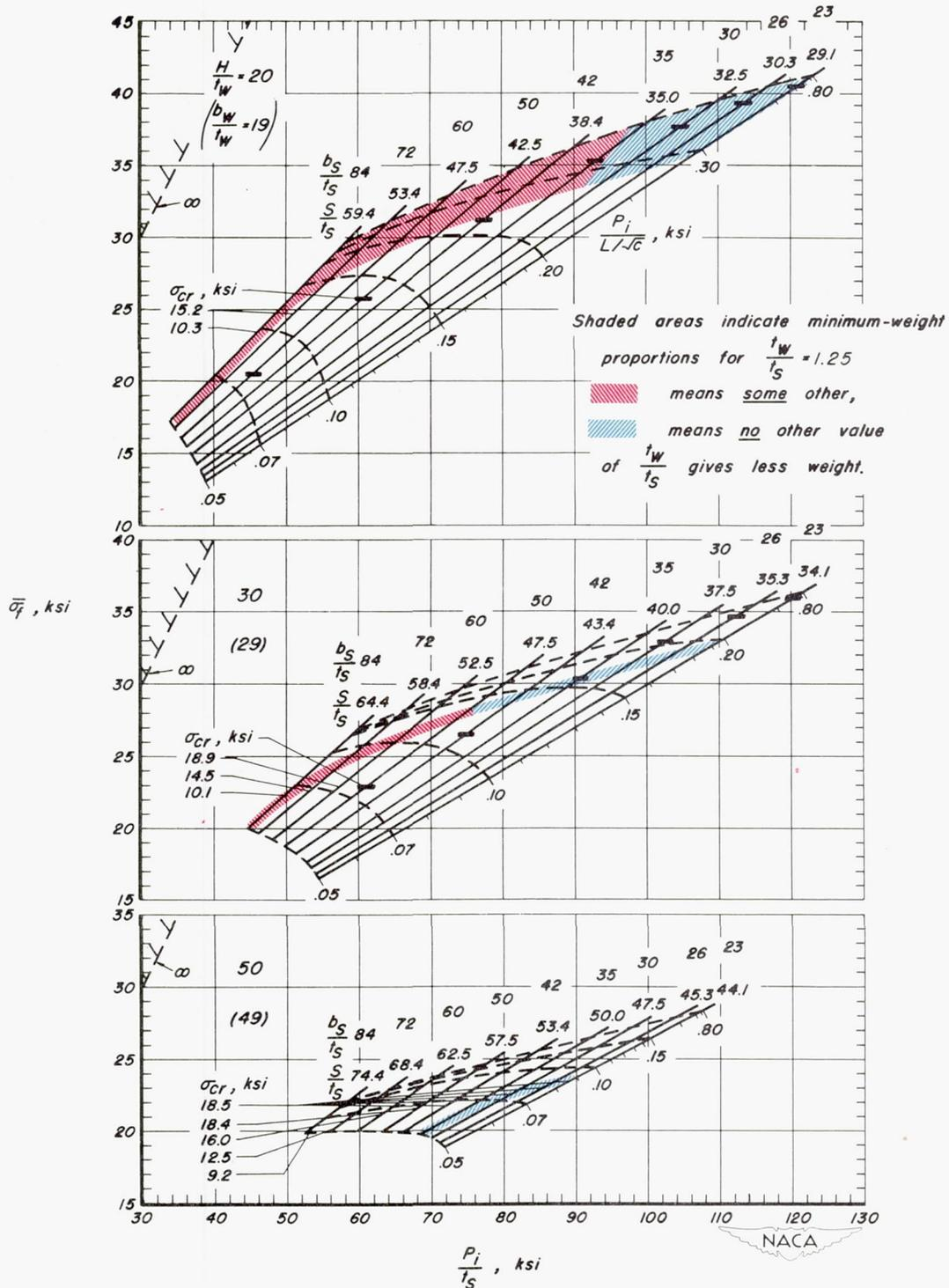

Figure 13.—Direct-reading design chart (alternate form) for flat compression panels of 24S-T3 aluminum alloy with formed hat-section stiffeners. $\frac{t_w}{t_s} = 1.25$

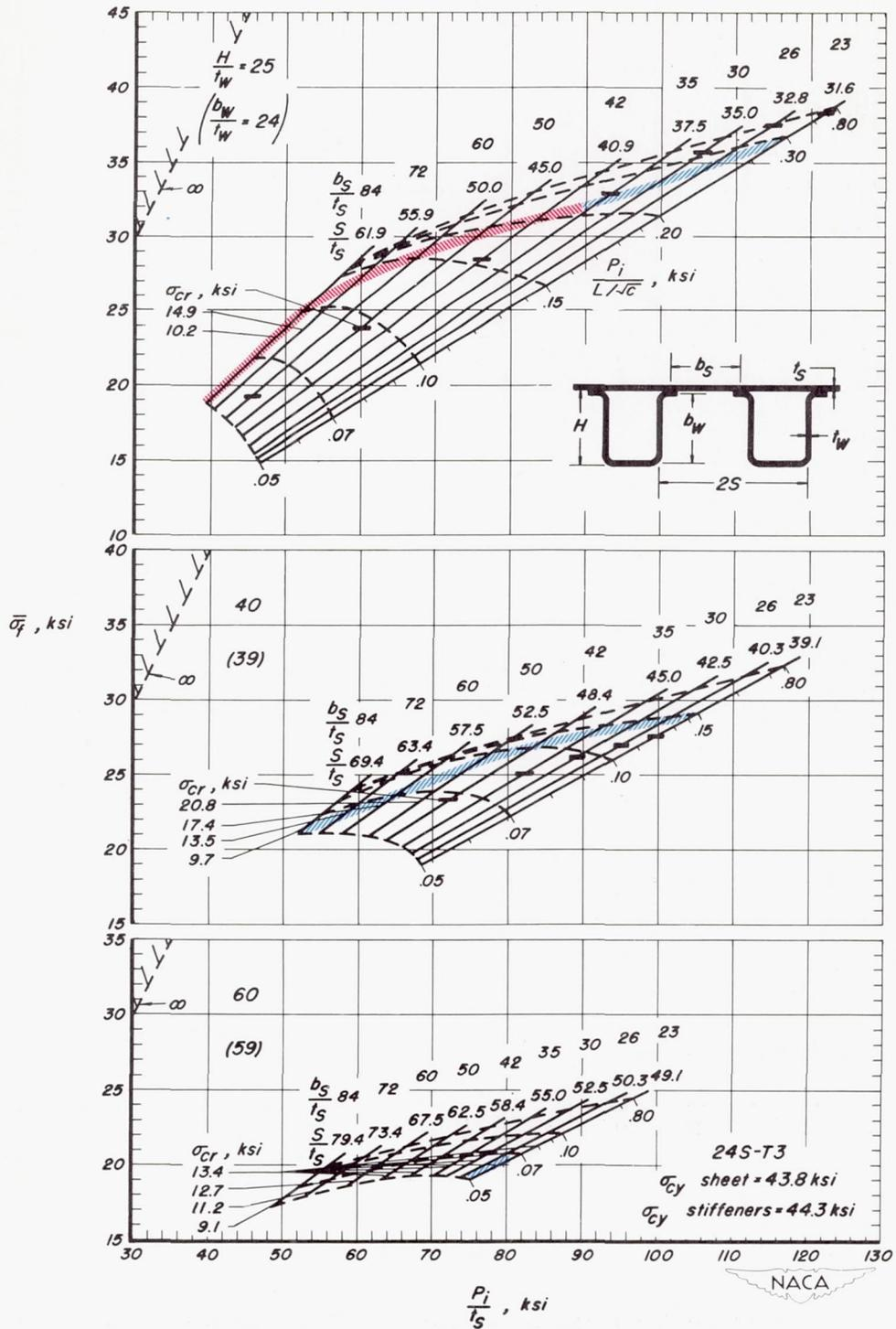

Figure 13.— Concluded

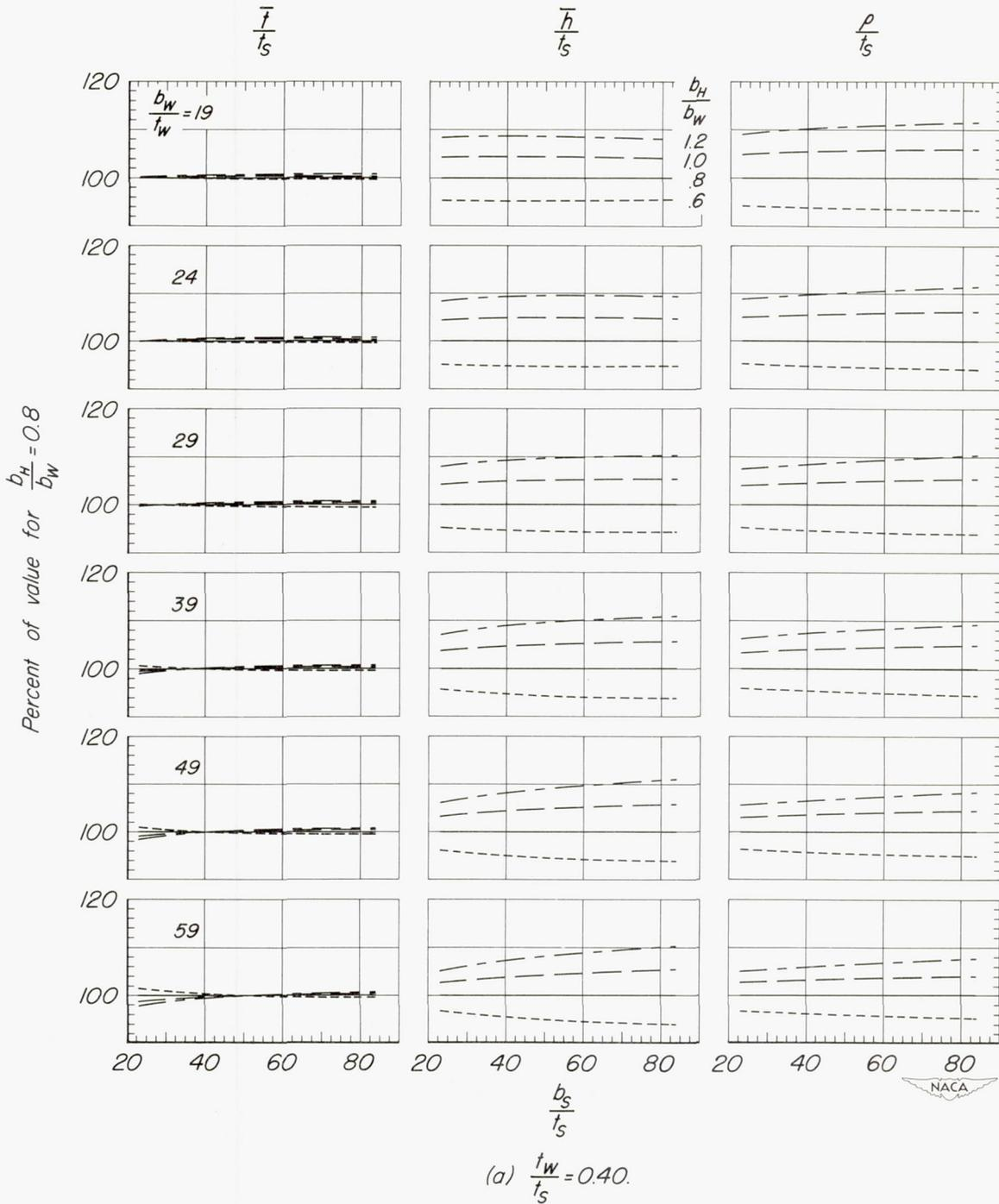

Figure 14.—Effect of variation in $\frac{b_H}{b_W}$ on section properties.

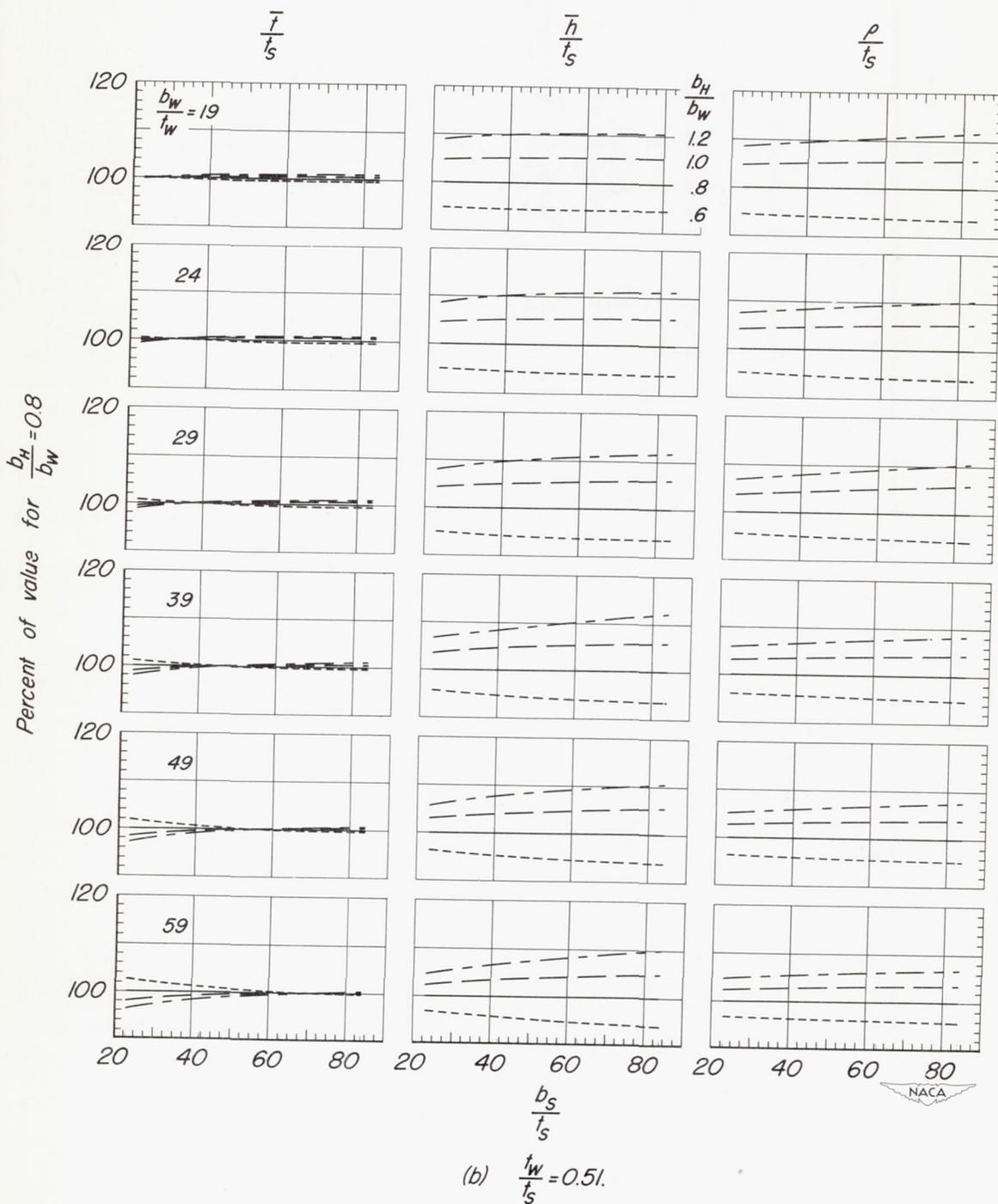

Figure 14.-Continued.

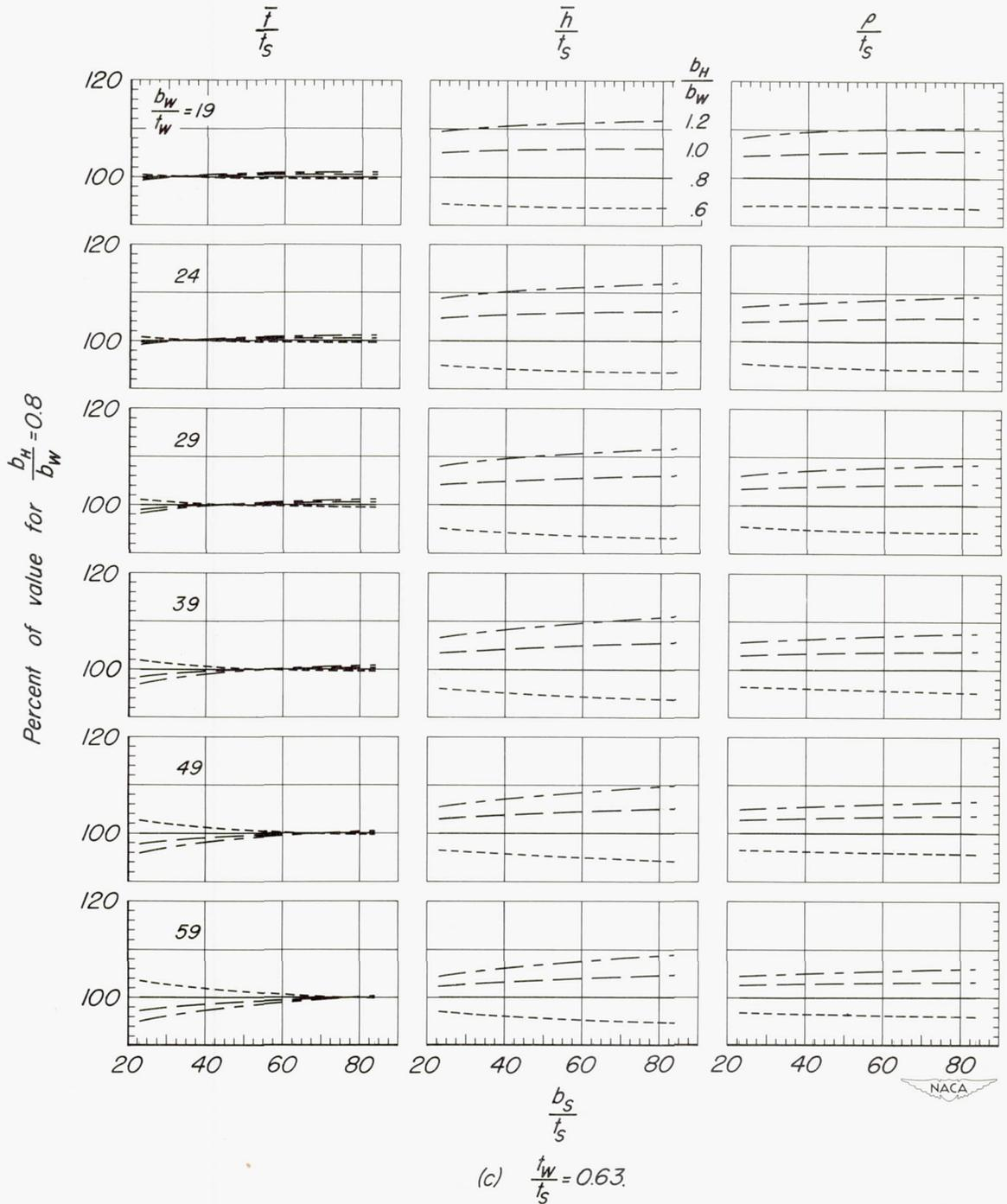
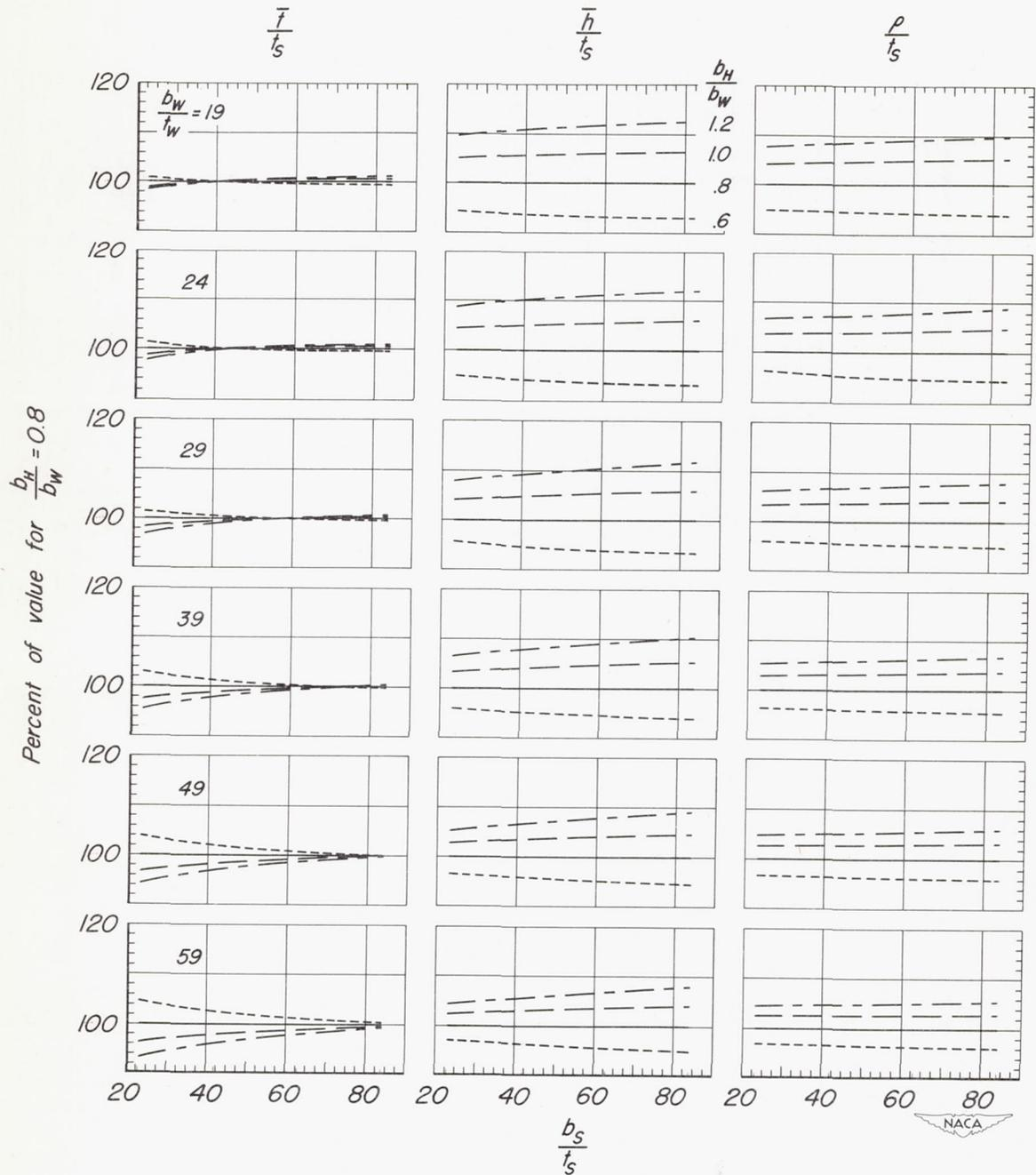

Figure 14.—Continued.



(d) $\frac{t_W}{t_S} = 0.79$.

Figure 14.-Continued.



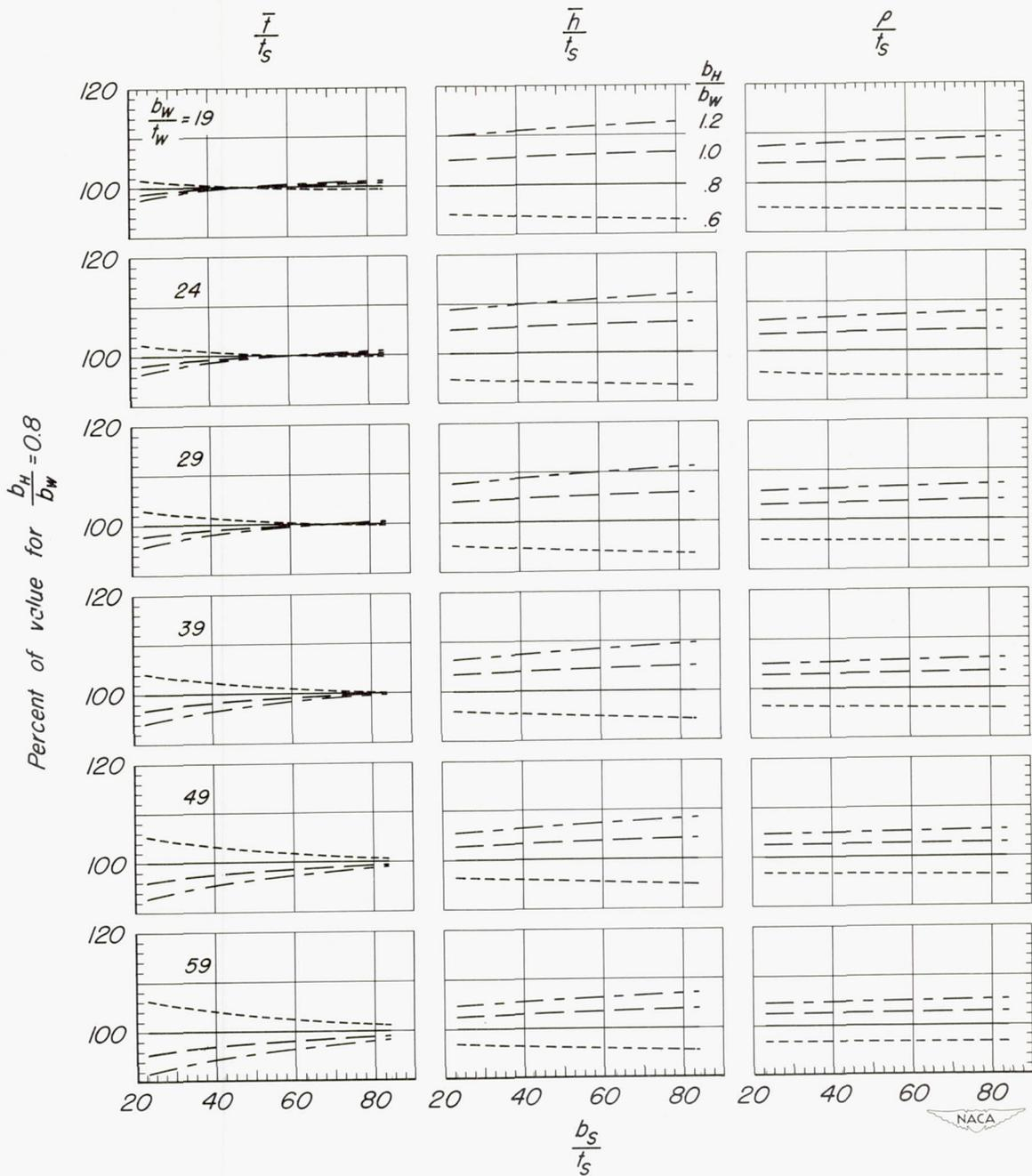

(e) $\frac{t_W}{t_S} = 1.00$.

Figure 14.—Continued.

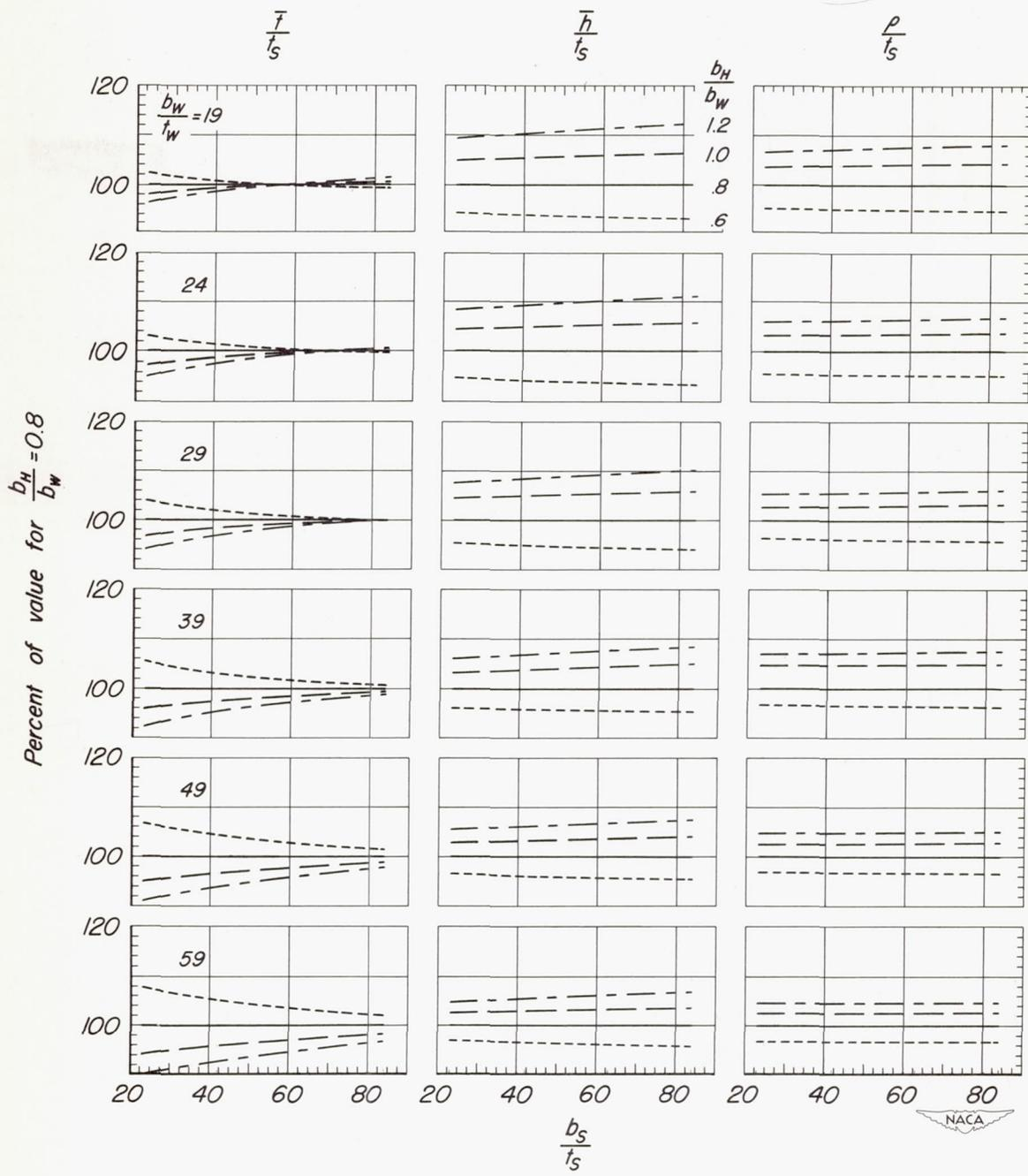

(f) $\frac{t_w}{t_s} = 1.25$.

Figure 14.—Concluded.

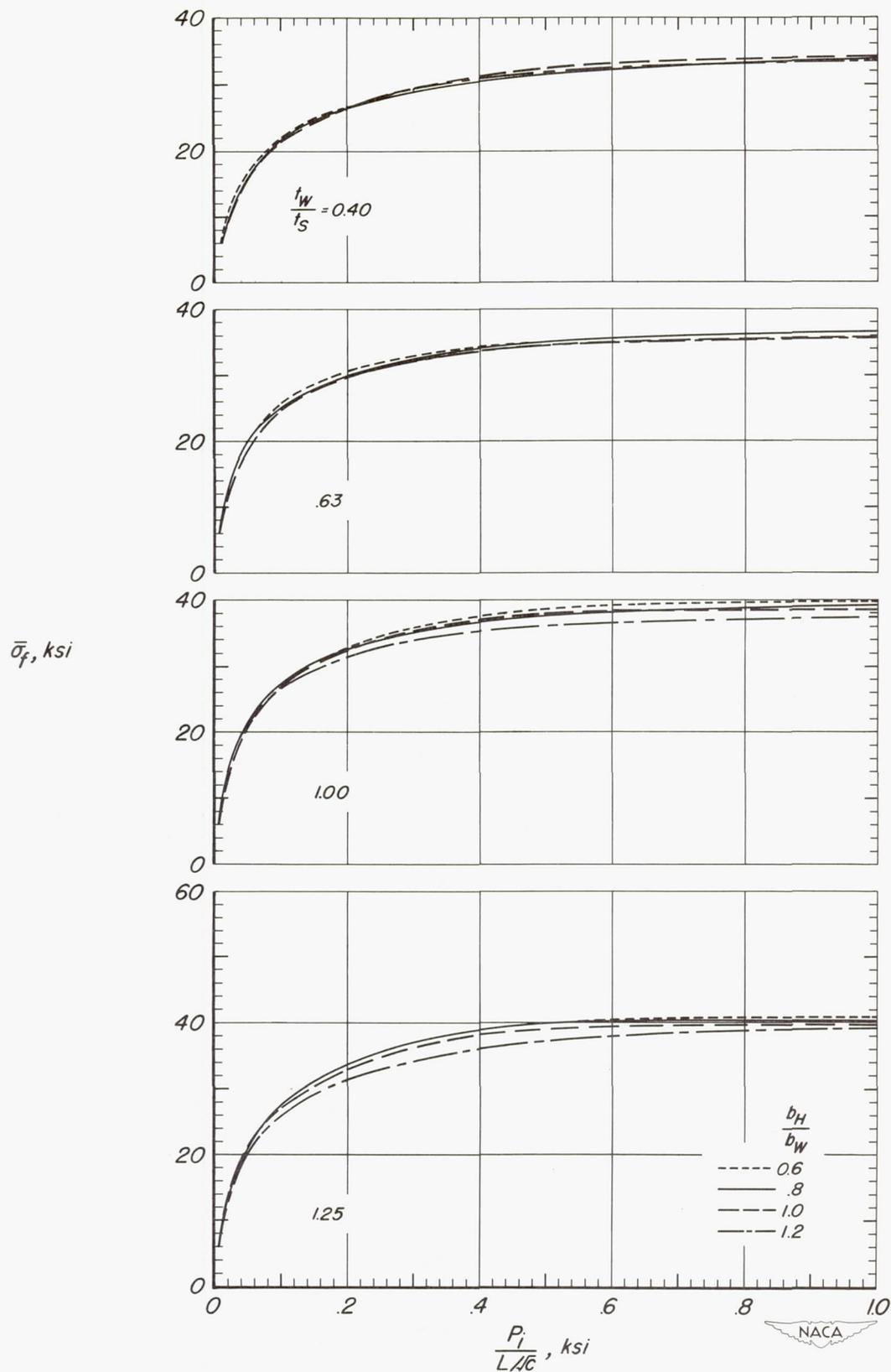

Figure 15.—Highest values of average stress at failure for 24S-T3 aluminum-alloy flat compression panels having formed hat-section stiffeners.

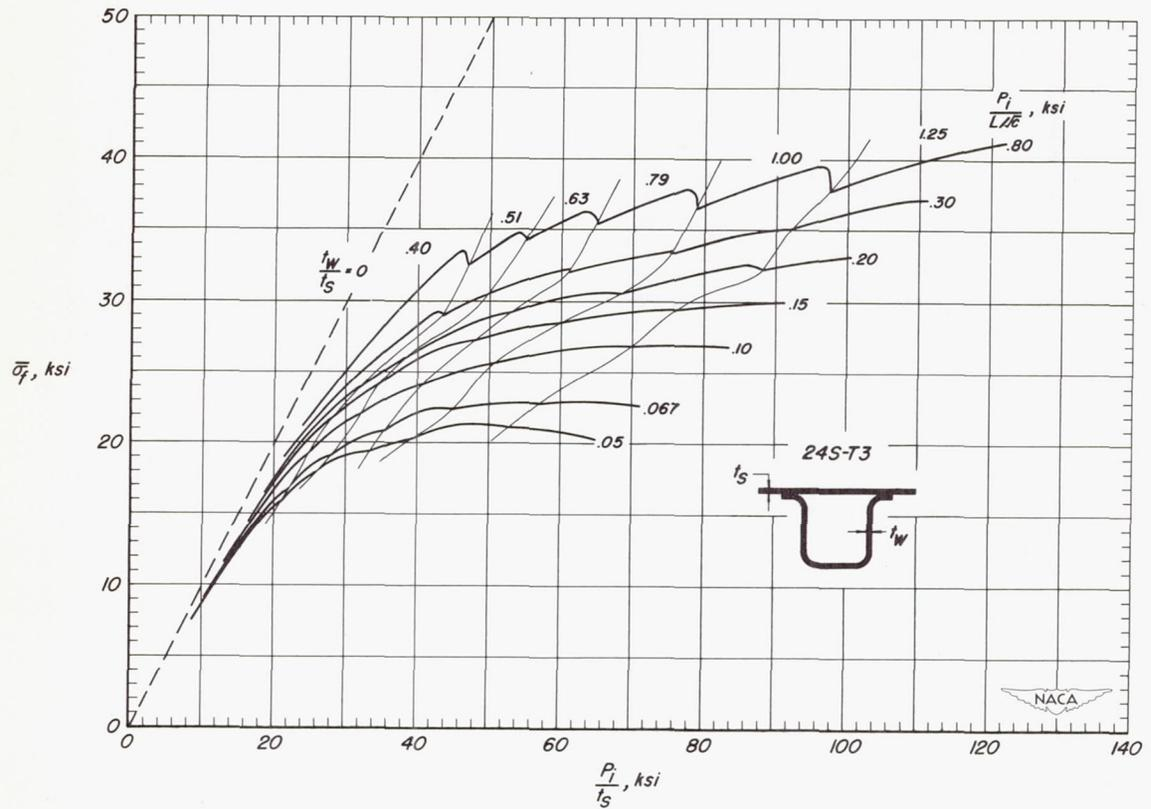

Figure 16.—Design chart for the determination of the average stress at failure that can be carried by minimum-weight designs of 24S-T3 aluminum-alloy flat compression panels having formed hat-section stiffeners.

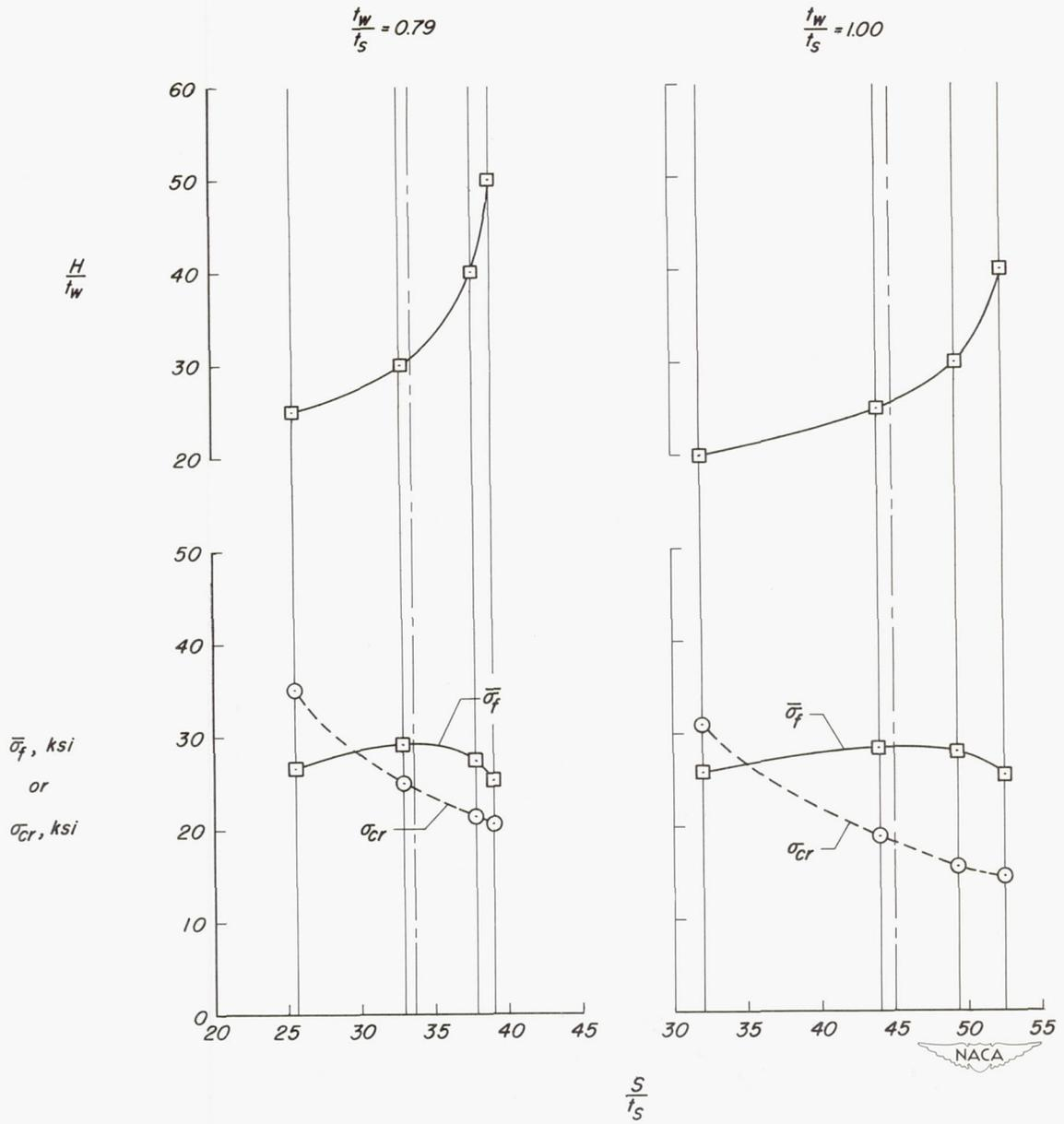

Figure 17.—Plot for obtaining design from design charts.

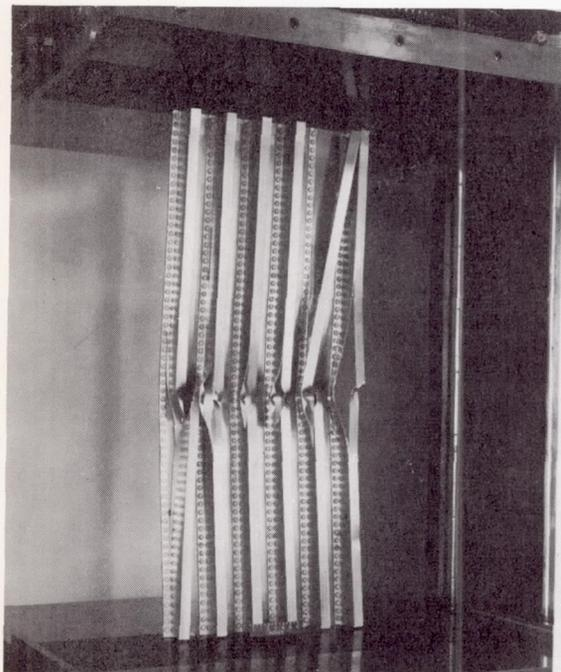
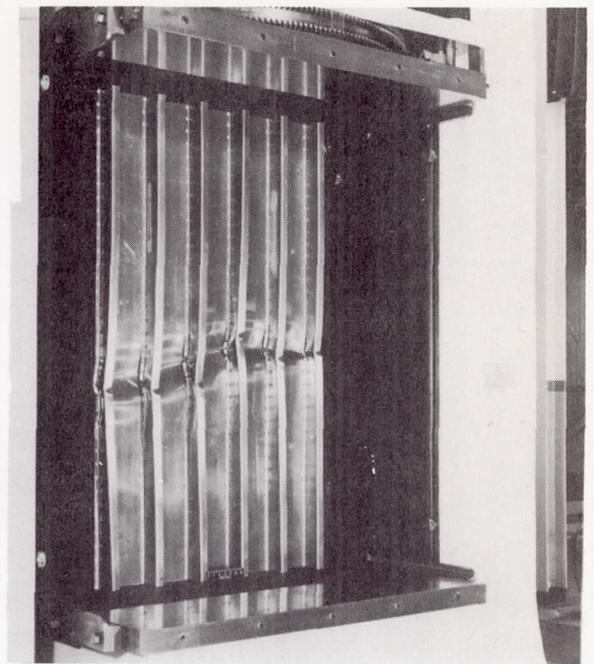
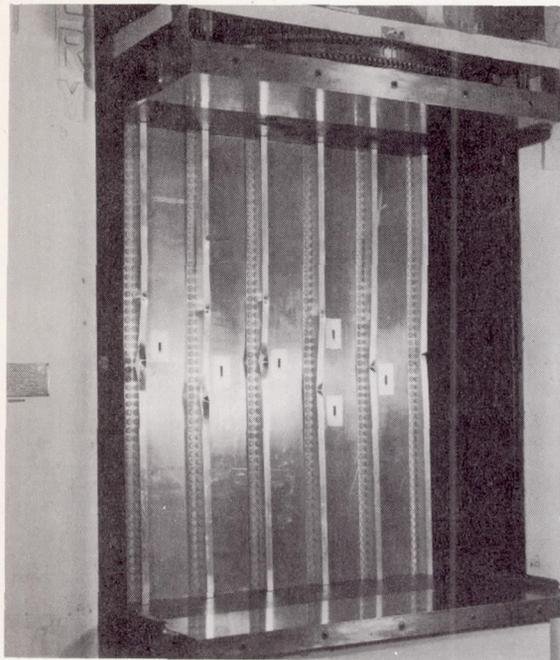
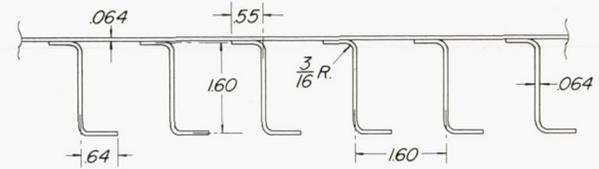
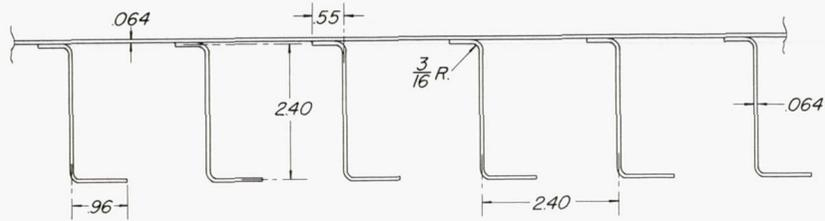

Figure 18.- Typical failure of Z-stiffened panels.



Rivets are $\frac{1}{8}$ diameter A17S-T4 at $\frac{3}{4}$ spacing

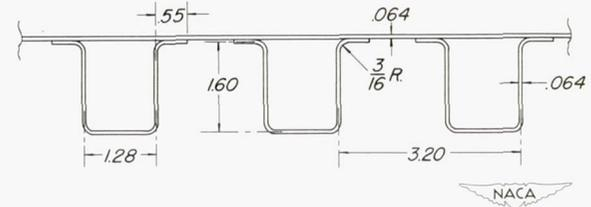
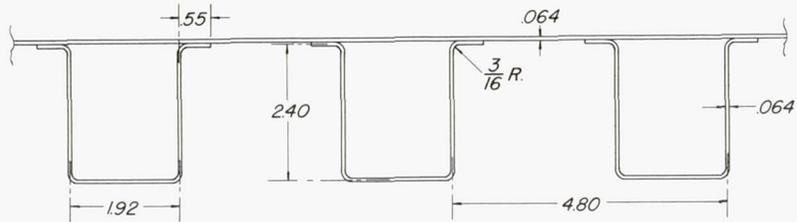

Figure 19.—Dimensions of comparative hat- and Z-stiffened panels.

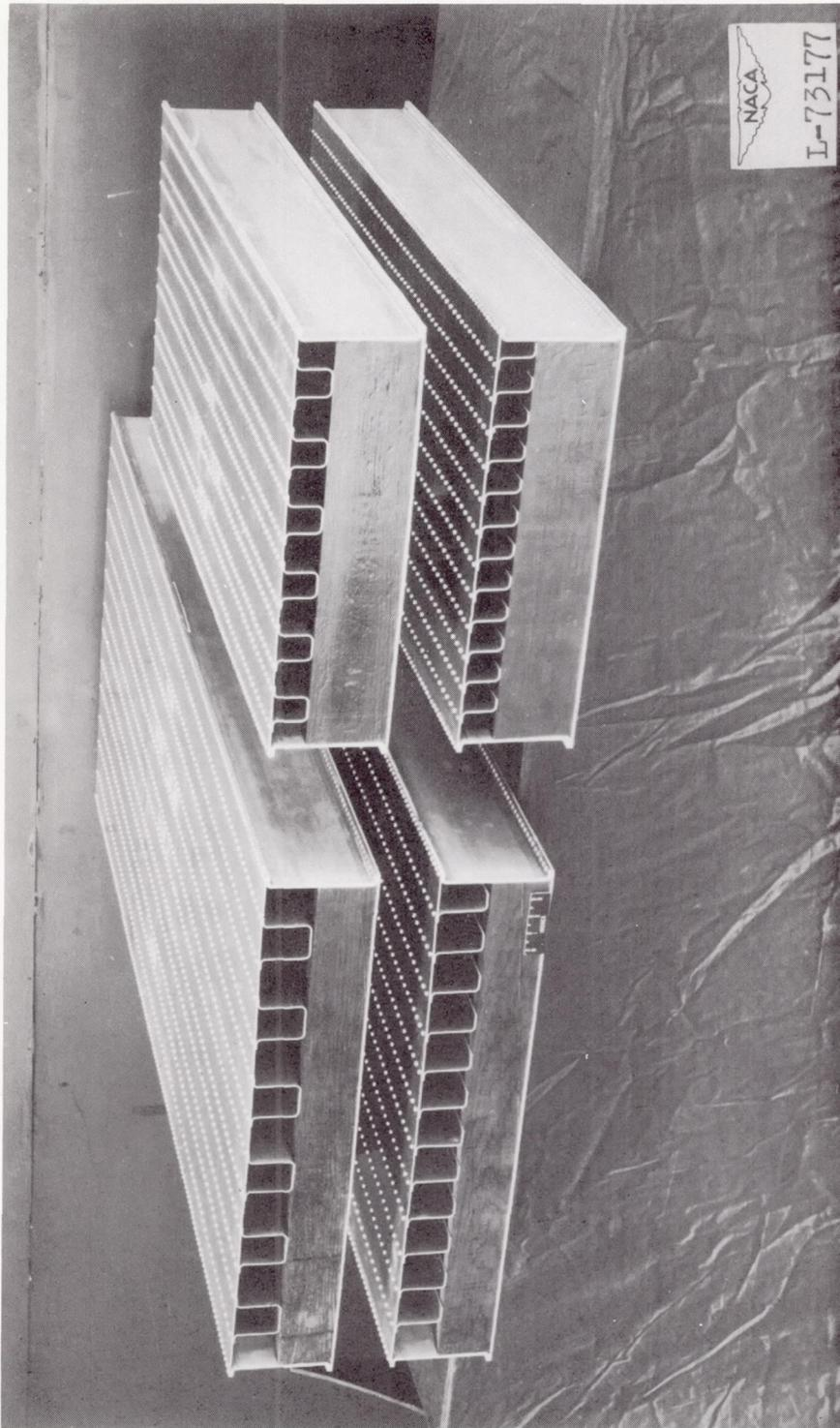

Figure 20.- Comparative Z- and hat-stiffened box beams.