

CASE FILE
COPY

1118

NACA TN 2836

NATIONAL ADVISORY COMMITTEE FOR AERONAUTICS

TECHNICAL NOTE 2836

RADIANT-INTERCHANGE CONFIGURATION FACTORS

By D. C. Hamilton and W. R. Morgan

Purdue University



Washington

December 1952



TN 2836

NATIONAL ADVISORY COMMITTEE FOR AERONAUTICS

TECHNICAL NOTE 2836

RADIANT-INTERCHANGE CONFIGURATION FACTORS

By D. C. Hamilton and W. R. Morgan

SUMMARY

This report is concerned with the geometric configuration factor for computing radiant interchange between opaque surfaces separated by a nonabsorbing medium. The configuration-factor solutions available in the literature have been checked and the more complicated equations are presented as families of curves. Several new configurations involving rectangles, triangles, and cylinders of finite length have been integrated and tabulated. The various methods of determining configuration factors are discussed and a mechanical integrator is described. An analysis is presented, in which configuration factors are employed, of the radiant heat transfer to the rotor blades of a typical gas turbine under different conditions of temperature and pressure.

INTRODUCTION

The many advantages have been evinced that would result from increased operating temperatures for gas turbines. This increase would require a greater amount of cooling if the use of nonstrategic materials is continued. At the lower operating temperatures the steady-state cooling requirements for the various internal components of the turbine may be determined by considering the heat transfer due to convection only. At the higher temperatures presently contemplated and at the even higher temperatures that will ultimately be envisioned, radiation will cease to be negligible and may well become the dominant mechanism. Since present trends indicate cooling nonstrategic materials as the means of increasing operating temperatures, it is important that the computation of radiant heat transfer be facilitated.

Unless a system is intentionally designed to facilitate computation of radiant heat transfer, this computation is, in general, a rather involved operation. The engineer desiring to compute the radiant heat transfer in a system such as a gas turbine is usually discouraged from performing more than a cursory estimation because of the excessive amount of time involved in obtaining the configuration factors. The absorptivity and emissivity of a surface are dependent upon composition of the surface, nature and thickness of film or oxide layer, magnitude and form of surface

asperities, and temperatures of the system. Since, in general, exact knowledge of these properties of the surfaces involved in a particular system in practice is not available, it is difficult to assign more than an approximate value to the emissivity or absorptivity.

To make the analysis mathematically feasible it is common practice to divide the system into zones, each of which is assigned a mean temperature. In this manner the postulate of isothermal surfaces or zones may be made. This latter simplification or idealization of the system introduces additional errors in the results.

The equation generally used for computing net interchange between two isothermal zones separated by a nonabsorbing medium is

$$q_{1-2} = \sigma A_1 f_{1-2} (T_1^4 - T_2^4)$$

The variable f_{1-2} is a function of the emissivities and absorptivities of surfaces A_1 and A_2 and of the configuration factors in which A_1 or A_2 are involved. (See appendix A for definitions of all symbols.) Equations for f are given in the literature for a limited number of simple systems (references 1 to 3). The emissivity and absorptivity values may be obtained from tables such as those given in references 1 or 2. There seems to be no source that gives the configuration factor for the commonly used elements of the geometry found in engineering structures. The present work leaves much yet undone, but it is hoped that there will be enough readily available configuration-factor values so that the time factor in radiant-heat-transfer calculations will be greatly reduced.

In using this report it is suggested that the reader consult appendix B, "Description of Configurations," to identify the geometry in question. That appendix gives the number of the figure in which the configuration factor is plotted. Configuration factors are given as a function of two or more parameters that are dimensionless ratios of significant lengths. These parameters are defined for each configuration in appendix B. The curves cannot be read so accurately as some of the points have been calculated. Therefore, if greater accuracy is desired, tables 1 to 14 should be consulted. The more complex equations are given in appendix C. An approximate analysis of the net radiant heat transfer to the rotor blades of a gas turbine is presented in appendix D. Configuration factors from the main text are employed in this analysis as necessary.

No attempt has been made to fix the credit for the integration of each of the configurations listed. Many of the publications are cited (references 4 to 25). However, some important ones may have gone unnoticed. The configurations named L-2, A-2, P-9, L-3, and L-4 were integrated for the first time by the present authors. All equations used herein were integrated by the present authors to insure against printing errors in the literature.

The equation for configuration A-2 was too complex to make calculation practicable; consequently, these values were computed by the numerical integration of L-2. Configurations L-3 and L-4 were also obtained by numerical integration.

The factor discussed in this paper has been called variously angle factor, shape factor, and configuration factor. The first name, angle factor, does not adequately describe the factor in question. The second, shape factor, has been consistently used in the literature as the name of the geometric factor in heat conduction. Because conduction and radiation often occur simultaneously and because shape factor has a unique meaning in heat conduction it appears that the geometric factor for radiation should be differently named to avoid confusion. The use of configuration factor is recommended since it has already been used many times and since it is adequately descriptive. The authors wish to acknowledge that the above discussion and recommendation came to them from Dr. G. A. Hawkins of Purdue University. Many of the references were brought to the authors' attention by Dr. W. L. Sibbitt. Dr. J. T. Agnew assisted with the calculations in appendix D.

This work was conducted at the Purdue University Engineering Experiment Station under the sponsorship and with the financial assistance of the National Advisory Committee for Aeronautics.

DEFINITION OF CONFIGURATION FACTOR

The configuration factor from A_1 to A_2 written F_{12} is herein defined as the fraction of the total radiant flux leaving A_1 that is incident upon A_2 . The configuration factor from a plane point source (point configuration factor) is obtained by integration over A_2 while the mean configuration factor from a line source or a finite source is an average of the point configuration factor over the line source or finite source, respectively. The configuration factor is a fraction that is a function of the geometry of the two surfaces; it also depends on the directional distribution of the radiation from the source. For the present discussion let a directional distribution function $D(\theta)$ be defined as follows:

$$D(\theta) = I(\theta)/I_m$$

where $I(\theta)$ is the intensity at the angle θ (measured from the normal to the plane point source) and I_m represents the mean value of the intensity defined by $I_m = W/\pi$. Experiments (see reference 25) indicate that most engineering materials do not exactly follow Lambert's cosine principle (reference 26); this principle gives values that are too low for polished conductors and too high for insulators at large values of the angle θ . Lambert's cosine principle states that the function $D(\theta)$ is a constant equal to unity and invariable with θ .

The error introduced by using Lambert's form of D in the calculation of radiant heat transfer has been assumed too small (in comparison with other calculation errors tolerated in practice) to warrant the complications introduced by the use of a more accurate form of D . Eckert (reference 25) gives a method for determining the configuration factor when a non-Lambertian distribution is postulated. One could integrate and tabulate configuration factors for the D functions typical of nonconductors and conductors; this may become desirable at some distant future date.

The configuration factor may be defined as the ratio of the radiant flux leaving a source that is incident on another surface to the total flux leaving the source. The limiting values are then zero and unity. After a form of the distribution function D is postulated, the configuration factor becomes a purely geometric function.

From figure 1 and the definition of the configuration factor for a radiating point source dA_1 and an intercepting area dA_2 , the configuration-factor equation is derived as:

$$dA_1 dF_{dA_1-dA_2} = \frac{I(\theta_1) \cos \theta_1 dA_1 d\omega_1}{\pi I_m} \quad (1)$$

where $d\omega_1$, the solid angle subtended by dA_2 at dA_1 , is

$$d\omega_1 = \frac{dA_2 \cos \theta_2}{r^2} \quad (2)$$

From equations (1) and (2) obtain

$$dA_1 dF_{dA_1-dA_2} = D_1(\theta_1) \frac{\cos \theta_1 \cos \theta_2 dA_1 dA_2}{\pi r^2} \quad (1a)$$

$$dA_2 dF_{dA_2-dA_1} = D_2(\theta_2) \frac{\cos \theta_1 \cos \theta_2 dA_1 dA_2}{\pi r^2} \quad (1b)$$

For any two areas dA_1 and dA_2 it follows from equations (1a) and (1b) that, if $D_1(\theta_1)$ and $D_2(\theta_2)$ are identical, the reciprocity theorem, equation (3), holds:

$$dA_2 dF_{dA_2-dA_1} = dA_1 dF_{dA_1-dA_2} \quad (3)$$

It is interesting to note that the reciprocity theorem fails when the distribution functions of the two surfaces are not identical. Thus, the reciprocity theorem is not true by definition, as some references have implied.

For the present work a Lambertian distribution will be postulated in which case D disappears from equations (1a) and (1b) and equation (3) applies.

The configuration factor $F_{dA_1-A_2}$ from dA_1 to A_2 is obtained by integrating equation (1a) over A_2 .

$$\begin{aligned} dA_1 F_{dA_1-A_2} &= dA_1 \int_{A_2} dF_{dA_1-dA_2} \\ &= dA_1 \int_{A_2} \frac{\cos \theta_1 \cos \theta_2 dA_2}{\pi r^2} \end{aligned}$$

Similarly, integration of equation (4) over A_1 gives $F_{A_1-A_2}$ from A_1 to A_2 :

$$\begin{aligned} A_1 F_{A_1-A_2} &= \int_{A_1} F_{dA_1-A_2} dA_1 \\ &= \int_{A_1} \int_{A_2} \frac{\cos \theta_1 \cos \theta_2 dA_1 dA_2}{\pi r^2} \end{aligned} \quad (5)$$

DETERMINATION OF CONFIGURATION FACTORS

Method of Mathematical Integration

In general, it is desirable to integrate the basic equation four times to obtain the solution for the configuration factor in terms of an algebraic equation that can be solved numerically for particular values of the parameters. An example will illustrate the method.

In figure 2 the geometry of configuration P-2 is shown. It is desired to determine the configuration factor $F_{dA_1-A_2}$ from the plane point source dA_1 to the finite rectangle A_2 . In figure 2 n_1 and n_2 are the normals to dA_1 and dA_2 , respectively; r is the length of the straight line connecting the two differential areas; and θ_1 and θ_2 are the angles between r and the respective normals.

From figure 2 the equations for $\cos \theta_1$, $\cos \theta_2$, and r can be given in terms of the coordinates x' and y' and the constants ϕ and a . These, when substituted in equation (4), give equation (6):

$$dA_1 F_{dA_1-A_2} = \frac{dA_1 \sin^2 \phi}{\pi} \int_0^m \int_0^h \frac{ay' dx' dy'}{\left[(x')^2 + (y')^2 + a^2 - (2ay' \cos \phi) \right]^2} \quad (6)$$

A change to dimensionless variables will, in general, simplify the integration. Let $x = x'/a$, $y = y'/a$, $M = m/a$, and $H = h/a$. Then

$$dA_1^F dA_{1-A_2} = \frac{dA_1 \sin^2 \phi}{\pi} \int_0^M \int_0^H \frac{y \, dy \, dx}{(y^2 - 2y \cos \phi + 1 + x^2)^2} \quad (6a)$$

Integration with respect to y yields

$$\begin{aligned} dA_1^F dA_{1-A_2} = \frac{dA_1 \sin^2 \phi}{\pi} \int_0^M & \left\{ \frac{H}{H - \cos \phi} \left[\frac{1}{x^2 + \sin^2 \phi} - \right. \right. \\ & \left. \left. \frac{1}{(1 + H^2 + x^2 - 2H \cos \phi)} \right] + \right. \\ & \left. \frac{\cos \phi}{(x^2 + \sin^2 \phi)^{3/2}} \left[\tan^{-1} \left(\frac{H - \cos \phi}{\sqrt{x^2 + \sin^2 \phi}} \right) + \right. \right. \\ & \left. \left. \tan^{-1} \left(\frac{\cos \phi}{\sqrt{x^2 + \sin^2 \phi}} \right) \right] \right\} dx \quad (7) \end{aligned}$$

and integration with respect to x gives

$$\begin{aligned} dA_1^F dA_{1-A_2} = \frac{1}{2\pi} & \left\{ \tan^{-1} M + \left(\frac{H \cos \phi - 1}{\sqrt{1 + H^2 - 2H \cos \phi}} \right) \tan^{-1} \left(\frac{M}{\sqrt{1 + H^2 - 2H \cos \phi}} \right) + \right. \\ & \left. \left(\frac{M \cos \phi}{\sqrt{M^2 + \sin^2 \phi}} \right) \left[\tan^{-1} \left(\frac{H - \cos \phi}{\sqrt{M^2 + \sin^2 \phi}} \right) + \tan^{-1} \left(\frac{\cos \phi}{\sqrt{M^2 + \sin^2 \phi}} \right) \right] \right\} \quad (8) \end{aligned}$$

Refer now to figure 3(a) for the third integration (over the x-axis of A_1):

$$F_{dA_1-A_2} = (F_{dA_1-A_2}' + F_{dA_1-A_2}'') \quad (9)$$

Combining equations (8) and (9) and integrating with respect to x get:

$$F_{dA_1-A_2} = \frac{1}{\pi} \left\{ \tan^{-1} M + \frac{\sin^2 \phi}{2M} \log_e \left[\frac{1 + H^2 + M^2 - 2H \cos \phi}{(1 + M^2)(1 + H^2 - 2H \cos \phi)} \right] - \frac{\sin \phi \cos \phi}{2M} \left[\tan^{-1} \left(\frac{H - \cos \phi}{\sin \phi} \right) + \right. \right. \\ \left. \left. \frac{\pi}{2} - \phi \right] + \left(\frac{H \cos \phi - 1}{\sqrt{1 + H^2 - 2H \cos \phi}} \right) \tan^{-1} \left(\frac{M}{\sqrt{1 + H^2 - 2H \cos \phi}} \right) + \right. \\ \left. \left(\frac{\cos \phi \sqrt{M^2 + \sin^2 \phi}}{M} \right) \left[\tan^{-1} \left(\frac{H - \cos \phi}{\sqrt{M^2 + \sin^2 \phi}} \right) + \tan^{-1} \left(\frac{\cos \phi}{\sqrt{M^2 + \sin^2 \phi}} \right) \right] \right\} \quad (10)$$

It should be noted that, in equation (10), dA_1 refers to a line source of width dz and of length M , whereas in all preceding equations dA_1 has pertained to a point source, both dimensions of which were of differential order.

To accomplish the final integration it is desirable to change to a new set of dimensionless variables: Let $N = h/m$, $L = a/m$, and $z = z'/m$:

$$F_{dA_1-A_2} = \frac{1}{\pi} \left\{ \tan^{-1} \left(\frac{1}{z} \right) + \frac{z \sin^2 \phi}{2} \log_e \left[\frac{z^2(z^2 - 2Nz \cos \phi + 1 + N^2)}{(1 + z^2)(z^2 - 2Nz \cos \phi + N^2)} \right] - z \sin \phi \cos \phi \left[\frac{\pi}{2} - \phi + \right. \right. \\ \left. \left. \tan^{-1} \left(\frac{N - z \cos \phi}{z \sin \phi} \right) \right] + \cos \phi \sqrt{1 + z^2 \sin^2 \phi} \left[\tan^{-1} \left(\frac{N - z \cos \phi}{\sqrt{1 + z^2 \sin^2 \phi}} \right) + \right. \right. \\ \left. \left. \tan^{-1} \left(\frac{z \cos \phi}{\sqrt{1 + z^2 \sin^2 \phi}} \right) \right] + \frac{N \cos \phi - z}{\sqrt{z^2 - 2Nz \cos \phi + N^2}} \tan^{-1} \left(\frac{1}{\sqrt{z^2 - 2Nz \cos \phi + N^2}} \right) \right\} \quad (10a)$$

Equation (10a) refers to figure 3(b). Integration of equation (10a) with respect to z over the interval from 0 to L gives:

$$F_{A_1-A_2} = \frac{1}{\pi L} \left(-\frac{\sin 2\phi}{4} \left[NL \sin \phi + \left(\frac{\pi}{2} - \phi \right) (N^2 + L^2) + L^2 \tan^{-1} \left(\frac{N - L \cos \phi}{L \sin \phi} \right) + N^2 \tan^{-1} \left(\frac{L - N \cos \phi}{N \sin \phi} \right) \right] + \right.$$

$$\left. \frac{\sin^2 \phi}{4} \log_e \left\{ \left[\frac{(1 + N^2)(1 + L^2)}{1 + N^2 + L^2 - 2NL \cos \phi} \right]^{\csc^2 \phi + \cot^2 \phi} \left[\frac{L^2(1 + N^2 + L^2 - 2NL \cos \phi)}{(1 + L^2)(N^2 + L^2 - 2NL \cos \phi)} \right]^{L^2} \right\} + \right.$$

$$\left. \frac{N^2 \sin^2 \phi}{4} \log_e \left[\left(\frac{N^2}{N^2 + L^2 - 2NL \cos \phi} \right) \left(\frac{1 + N^2}{1 + N^2 + L^2 - 2NL \cos \phi} \right)^{\cos 2\phi} \right] + L \tan^{-1} \left(\frac{1}{L} \right) + \right.$$

$$\left. N \tan^{-1} \left(\frac{1}{N} \right) - \sqrt{N^2 + L^2 - 2NL \cos \phi} \cot^{-1} \sqrt{N^2 + L^2 - 2NL \cos \phi} + \right.$$

$$\left. \frac{N \sin \phi \sin 2\phi}{2} \sqrt{1 + N^2 \sin^2 \phi} \left[\tan^{-1} \left(\frac{N \cos \phi}{\sqrt{1 + N^2 \sin^2 \phi}} \right) + \tan^{-1} \left(\frac{L - N \cos \phi}{\sqrt{1 + N^2 \sin^2 \phi}} \right) \right] + \right.$$

$$\left. \cos \phi \int_0^L \sqrt{1 + z^2 \sin^2 \phi} \left[\tan^{-1} \left(\frac{N - z \cos \phi}{\sqrt{1 + z^2 \sin^2 \phi}} \right) + \tan^{-1} \left(\frac{z \cos \phi}{\sqrt{1 + z^2 \sin^2 \phi}} \right) \right] dz \right) \quad (11)$$

Equation (11) is too complex algebraically to make numerical solution of it practicable; for this reason the last integral was not solved and the values for $F_{A_1-A_2}$ (configuration A-2) were obtained by the numerical integration of the values obtained for configuration L-2 from equation (10a).

For the particular case of ϕ equal to 90° the equation simplifies to:

$$F_{A_1-A_2} = \frac{1}{\pi L} \left(L \tan^{-1} \left(\frac{1}{L} \right) + N \tan^{-1} \left(\frac{1}{N} \right) - \sqrt{N^2 + L^2} \cot^{-1} \sqrt{N^2 + L^2} + \right. \\ \left. \frac{1}{4} \left\{ \log_e \left[\frac{(1 + L^2)(1 + N^2)}{1 + L^2 + N^2} \right] + L^2 \log_e \left[\frac{L^2(1 + N^2 + L^2)}{(1 + L^2)(N^2 + L^2)} \right] + \right. \right. \\ \left. \left. N^2 \log_e \left[\frac{N^2(1 + N^2 + L^2)}{(1 + N^2)(N^2 + L^2)} \right] \right\} \right) \quad (11a)$$

The labor involved in the first two integrations can generally be reduced by use of Stokes' theorem and vector calculus.

Methods of Determining "Point" Configuration Factors

Based on Double-Projection Principle of Nusselt

The following methods apply Nusselt's geometric interpretation of the configuration-factor equation (reference 5) in one way or another to get configuration factors in which the source is a plane point source. The "point" configuration-factor equation is:

$$F_{dA_1-A_2} = \int_{A_1} \frac{\cos \theta_1 d\omega_1}{\pi} \quad (4a)$$

In figure 4 it is seen that the solid angle $d\omega_1$ subtended by dA_2 at dA_1 is

$$d\omega_1 = \frac{\cos \theta_2 dA_2}{R^2} = \frac{dA_2'}{r^2}$$

where dA_2' is the radial projection of dA_2 on the surface of the sphere of radius r . Also, $dA_2'' = dA_2' \cos \theta_1$; therefore, the configuration factor is interpreted as:

$$F_{dA_1-A_2} = \frac{A_2''}{\pi r^2} \quad (12)$$

To recapitulate, let a hemisphere of radius r be constructed about the plane point source dA_1 with the point source in the plane of the base of the hemisphere. Let each point on the perimeter of A_2 be projected radially to the surface of the hemisphere, thence vertically (parallel to the normal to dA_1) down to the base of the hemisphere. The ratio of this projected area A_2'' on the base of the hemisphere to the area of the entire base of the hemisphere is the desired "point" configuration factor from dA_1 to A_2 .

Drawing-board solution.- By the methods of elementary descriptive geometry the point configuration factor can be obtained by projecting the various points on A_2 to the base of a hemisphere constructed about the radiating point source. Simple geometry such as in configurations P-3 and P-4 (appendix B) may be solved quickly by drawing-board projection.

Transit method.- If the desired configuration factor is associated with a relatively large structure already built, the point configuration factors can be obtained by using a surveyor's transit with an elbow-telescope attachment to permit vertical shots. If θ represents the angle in a vertical plane (measured from the horizon) and ϕ represents the angle in the horizontal plane (measured from some arbitrary place) and readings are taken of these angles for strategic points on the perimeter of the intercepting area, then a plot of $\cos^2\theta$ against ϕ will give an area that is proportional to the configuration factor.

Optical projection method of Eckert.- The optical projection method of Eckert (reference 27) employed a point light source situated in the center of the base of a milk-glass hemisphere as shown in figure 5. Paper models were suspended by small wires from the base. The models cast a shadow on the milk-glass hemisphere. Photographs were taken at a great distance from the hemisphere. The area of the image of the shadow on the film divided by the area of the image of the hemisphere was a measure of the configuration factor from a point source at the center of the base of the hemisphere to the paper model. Excellent results were obtained with this apparatus.

Mechanical integrator.- The first mechanical integrator was designed by Hottel (reference 28). To operate this apparatus a telescoping pointer was caused to trace the perimeter of a scale model of the intercepting area while a scribe traced the projection on the paper. The configuration factor was determined by planimetering the area. Cherry, Davis, and Boelter (reference 29) designed a more elaborate mechanical integrator which was similar to Hottel's instrument with the exception that the pointer was replaced by a light beam which was caused to trace the perimeter of the model in a semidarkened room. An integrator that is similar but smaller than that in reference 29 was built at the NACA Lewis Flight Propulsion Laboratory. Another mechanical integrator was designed at Purdue University (figs. 6 and 7) that employed a different type of mechanism. It consists essentially of a parallelogram linkage with an optical system. The cross hairs of the telescope are caused to follow the perimeter of the model of the intercepting area and the resulting projected area is traced on the paper by the scribe. The precision is less than 1 percent. This integrator was used to check various points on the curves given in this report.

Photographic Methods

Jakob and Hawkins (reference 30) have developed a method in which the model of the intercepting surface is covered with photographic film and the interchange of thermal energy is replaced by the emission and absorption of light. Area sources may be used with this technique. The effect of an absorbing gas can be imitated by filling the cavity with a light-absorbing medium.

England and Croft (reference 31) employed a similar method.

Approximation Method

The approximation method consists of subdividing the intercepting area into a number of finite areas; for any particular area the finite-difference form of equation (3) is used:

$$F_{dA_1-\Delta A_2} = \frac{\cos \theta_1 \cos \theta_2 \Delta A_2}{\pi r^2} \quad (4b)$$

The radius r is computed as the distance between the centers of the two areas dA_1 and ΔA_2 , and the angles are measured between r and

the respective normals. The sum of the configuration factors to all the ΔA_2 's is an approximate value of $F_{dA_1-A_2}$. Any desired accuracy can be attained depending on the number of times the area A_2 is subdivided.

Determination of Mean Configuration Factors

Methods based on the projection principle of Nusselt can be used only to obtain point configuration factors. Let it be assumed that the point configuration factors from the various points on the triangular-shaped area (fig. 8) to some intercepting area A_2 have been determined as:

$$F_{1a-A_2} = 0.1$$

$$F_{2a-A_2} = 0.25$$

$$F_{1b-A_2} = 0.2$$

$$F_{2b-A_2} = 0.45$$

$$F_{1c-A_2} = 0.07$$

$$F_{2c-A_2} = 0.1$$

The first operation involves obtaining the mean configuration factor for various line sources located at a unique value of x . Using Simpson's one-third rule, one obtains 0.162 and 0.358 for the mean line-source configuration factors $F(x/L)$ at values of x/L equal to 0.5 and 1, respectively.

The mean configuration factor $F_{A_1-A_2}$ is found by:

$$F_{A_1-A_2} = \frac{1}{A_1} \int_{A_1} F(x/L) dA$$

but $dA = 2hL(x/L) d(x/L)$.

Thus

$$F_{A_1-A_2} = 2 \int_0^1 [(x/L)F(x/L)] d(x/L)$$

In figure 8 the values of $2(x/L)F(x/L)$ are plotted against x/L . The area under the smooth curve drawn through these points is equal to $F_{A_1-A_2}$.

GEOMETRIC FLUX ALGEBRA

In a system composed of n "isothermal" zones, the following equation, written for the p th surface, applies to each of the n surfaces because of the definition of the configuration factor:

$$\sum_{i=1}^n F_{A_p-A_i} = 1 \quad (13)$$

Thus, when $n - 1$ configuration factors for a given area are known, the other may be determined from equation (13). Also, because of the use of Lambert's form of the directional distribution function, the reciprocity theorem applies:¹

$$A_1 F_{12} = A_2 F_{21} \quad (14)$$

For the system under discussion, n equations of the form of equation (13) can be written, and $\frac{1}{2} n(n - 1)$ different forms of the reciprocity equation (equation (14)) exist. If none of the n surfaces are reentrant (i.e., $F_{11} = F_{22} = F_{33} \dots = 0$), then only $\frac{1}{2} (n - 1)(n - 2)$ configuration factors must be independently determined, say from curves; the remainder are quickly obtainable by use of equations of the form of equations (13) and (14) mentioned above. If i of the n surfaces are reentrant, the above number of independent configuration factors is greater by $i - 1$.

This section gives simple rules whereby the usefulness of some of the configuration factors can be extended.

¹Hereafter, for brevity of notation, when the magnitudes of the source and intercepting areas are otherwise apparent, $F_{A_1-A_2}$ will be written F_{12} .

The association of some physical concept with a function usually decreases somewhat the apparent difficulty in its use. A fictitious system will be created for the one purpose of permitting the $A_1 F_{12}$ product to assume the role of a flux. The radiant flux ϕ_{12} represents the radiant energy (in Btu/hr) leaving A_1 incident on A_2 . Since the configuration factor is a purely geometric function, let a fictitious system be postulated (used only during the process of determining configuration factors) in which each surface is an isothermal black body at a temperature such that the emissive power W is equal to one British thermal unit per hour per square foot. The general equation for the flux ϕ_{12} from A_1 to A_2 is given by equation (15):

$$\phi_{12} = W_1 A_1 F_{12} \quad (15)$$

$$G_{12} = (1) A_1 F_{12} \quad (16)$$

For this system equation (15) reduces to equation (16), where G_{12} is the geometric flux from A_1 to A_2 and is numerically equal to the product $A_1 F_{12}$. By definition of the system the second law of thermodynamics requires that $G_{12} = G_{21}$. This is the reciprocity theorem. In a composite system the geometric fluxes follow the laws of arithmetic:²

$$\begin{aligned} G_{(12)(34)} &= G_{(12)3} + G_{(12)4} \\ &= G_1(34) + G_2(34) \\ &= G_{13} + G_{14} + G_{23} + G_{24} \end{aligned} \quad (17)$$

In figure 9 the rectangles A_1 , A_3 , A_7 , and A_9 are located by the values of the various x_1 and y_1 coordinates a , b , c ,

²In the composite-system notation $G_{(12)(34)}$ means the G from the area $(A_1 + A_2)$ to the area $(A_3 + A_4)$ and $G_1(34)$ means the G from the area A_1 to the area $(A_3 + A_4)$.

and so forth. The identical and directly opposed rectangles A_1' , A_3' , and so forth are the projections of these areas on a parallel plane with the distance between planes of z units. It is desired that the configuration factor $F_{A_1-A_9'}$ ($F_{19'}$) be determined as a function of configuration factors of the type of configuration A-1.

The equation for $G_{19'}$ is:

$$G_{19'} = \frac{z^2}{\pi} \int_a^b dx_1 \int_g^h dy_1 \int_c^d dx_2 \int_e^f dy_2 \frac{1}{\left[(x_2 - x_1)^2 + (y_2 - y_1)^2 + z^2 \right]^2} = A_1 F_{19'}$$

$$G_{37'} = \frac{z^2}{\pi} \int_c^d dx_1 \int_g^h dy_1 \int_a^b dx_2 \int_e^f dy_2 \frac{1}{\left[(x_2 - x_1)^2 + (y_2 - y_1)^2 + z^2 \right]^2}$$

Because of the symmetry of the integrand of these equations, it follows that:

$$G_{19'} = G_{37'} = G_{91'} = G_{73'} \quad (18)$$

Application of the reciprocity theorem will add four other geometric fluxes to this identity. With these expressions and flux algebra one gets $G_{19'}$ in terms of G 's, each of which is

of the type of configuration A-1. To shorten the notation, let $G_{(12345)2} = G_{(12345)(1'2'3'4'5')}$:

$$G_{19'} = \frac{1}{4} \left\{ G_{(123456789)2} - \left[G_{(125678)2} + G_{(234589)2} + G_{(456789)2} + G_{(123456)2} \right] + \left[G_{(1256)2} + G_{(2345)2} + G_{(4589)2} + G_{(5678)2} \right] + \left[G_{(456)2} + G_{(258)2} \right] - \left[G_{(25)2} + G_{(45)2} + G_{(58)2} + G_{(56)2} \right] \right\} \quad (19)$$

Since $G_{19'} = A_1 F_{19'}$, $G_{(2345)2} = (A_2 + A_3 + A_4 + A_5) F_{(2345)2}$, and so forth, these substitutions should be made to solve for $F_{19'}$.

In a similar manner the following expressions are obtained:

$$G_{12'} = \frac{1}{2} \left[G_{(12)2} - G_{12} - G_{22} \right] \quad (20)$$

$$G_{15'} = \frac{1}{4} \left[G_{(1256)2} + G_{12} + G_{22} + G_{52} + G_{62} \right] - \frac{1}{4} \left[G_{(12)2} + G_{(16)2} + G_{(25)2} + G_{(56)2} \right] \quad (21)$$

In figure 10 it is easy to get:

$$G_{16'} = G_{(16)6'} - G_{66'} \quad (22)$$

$$G_{11'} = G_{(16)(1'6')} - G_{(16)6'} - G_{6(1'6')} + G_{66'} \quad (23)$$

The G's in the right members are all of the form of configuration A-2.

Further extensions require an identity such as those obtained previously. In figure 10

$$G_{13'} = \frac{\sin^2 \phi}{\pi} \int_e^f dy_1 \int_g^h dy_2 \int_a^b dx_1 \int_c^d \frac{y_1 y_2 dx_2}{\left[(x_2 - x_1)^2 + y_1^2 + y_2^2 - 2y_1 y_2 \cos \phi \right]^2}$$

$$G_{31'} = \frac{\sin^2 \phi}{\pi} \int_e^f dy_1 \int_g^h dy_2 \int_c^d dx_1 \int_a^b \frac{y_1 y_2 dx_2}{\left[(x_2 - x_1)^2 + y_1^2 + y_2^2 - 2y_1 y_2 \cos \phi \right]^2}$$

Again, because of symmetry of the integrand,

$$G_{13'} = G_{31'} = G_{3'1} = G_{1'3} \quad (24)$$

The following equations can now be obtained:

$$G_{65'} = \frac{1}{2} \left[G_{(56)2} - G_{52} - G_{62} \right] \quad (25)$$

$$\begin{aligned}
G_{13'} = \frac{1}{2} & \left[G_{(123456)^2} - G_{(2345)^2} - G_{(1256)^2} + G_{(456)^2} - \right. \\
& G_{(456)(1'2'3'4'5'6')} - G_{(123456)(4'5'6')} + G_{(1256)(5'6')} + \\
& G_{(2345)(4'5')} + G_{(56)(1'2'5'6')} + G_{(45)(2'3'4'5')} + \\
& \left. G_{(25)^2} - G_{(25)5'} - G_{(56)^2} - G_{(45)^2} - G_{5(2'5')} + G_{52} \right] \quad (26)
\end{aligned}$$

In equations (19) and (26) the error in the result, $G_{19'}$ or $G_{13'}$, may be many times the error in reading the curves. These equations should therefore be used with caution. The use of an accurate interpolation formula and the tabulated values of the configuration factors will give sufficient accuracy to make equations (19) and (26) practicable. The approximation method is always applicable when other devices fail.

Purdue University
Lafayette, Ind., August 13, 1951

APPENDIX A

SYMBOLS

A	area, square feet
$\left. \begin{array}{l} a, h, i, k, \\ m, n, p \end{array} \right\}$	constants
$D(\theta)$	directional distribution function
e	surface emissivity
F_{1-2}	Lambertian geometric configuration factor from surface A_1 to surface A_2
f_{1-2}	factor accounting for effect of geometry and emissivity of solid surfaces and gases contributing to net radiation between A_1 and A_2
G_{12}	geometric flux from A_1 to A_2 , Btu per hour
H	constant
h_c	convective-heat-transfer coefficient, Btu/(hr)(sq ft)(°F)
h_r	equivalent radiant-heat-transfer coefficient, Btu/(hr)(sq ft)(°F)
$I(\theta)$	areal intensity of radiation, Btu/(hr)(sq ft)(steradian)
L	constant; also mean beam length, feet
M, N	constants
q	rate of net heat transfer, Btu per hour
r	length variable, feet
T	static temperature, °F or °F absolute, whichever is applicable
V	gas volume, cubic feet
W	emissive power, Btu/(hr)(sq ft)

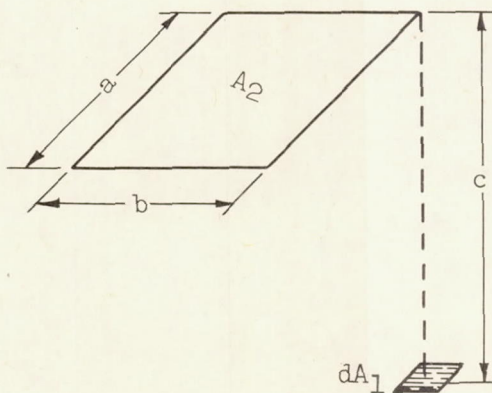
x, y, z	spatial variables, feet
α	surface absorptivity
Δ	symbol indicating small but finite part of
θ, ϕ	angles
σ	Stefan-Boltzmann constant, 0.173×10^{-8} Btu/(hr)(sq ft)($^{\circ}$ F abs.) ⁴
ϕ	radiant flux, Btu per hour
ω	solid angle, steradian
Subscripts:	
b	rotor blade
c	casing
e	effective
g	gas
g,e	gas in combustion chamber
g,t	gas in tail cone
g,t,ab	gas in tail cone with afterburner operating (this gas body begins 1 ft behind rotor blades)
m	mean
s	stator blades
sh	rotor-blade shroud
t	tail-cone surface
x	line source on rotor blade at a distance x from leading edge

APPENDIX B

DESCRIPTION OF CONFIGURATIONS

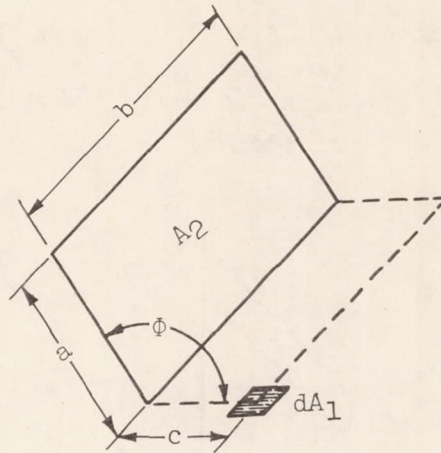
The configurations described have been named so that it is obvious that the source, or first subscript area, of the configuration factor is either a plane point source (P-1 etc.), a plane line source (L-1 etc.), or a finite-area source (A-1 etc.). The configuration factors are given as functions of two or more parameters which are dimensionless ratios of significant lengths and these parameters are defined herein for each configuration. The configurations are as follows:

Configuration P-1: A plane point source dA_1 and a plane rectangle A_2 parallel to the plane of dA_1 (see sketch). The normal to dA_1 passes through one corner of A_2 . The curves for this configuration are given in figure 11 where F_{12} is plotted as a function of x and y with $x = a/c$ and $y = b/c$. The equation for F_{12} is presented in appendix C and the configuration-factor values are given in table 1.

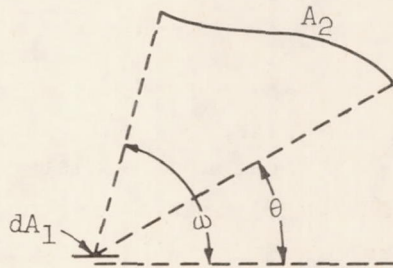


Configuration P-2: A plane point source dA_1 and a plane rectangle A_2 , the planes of dA_1 and A_2 intersecting at an angle ϕ ($0^\circ < \phi < 180^\circ$). The configuration-factor values are given in table 2 and the curves plotted in figure 12 for various values of ϕ , N ,

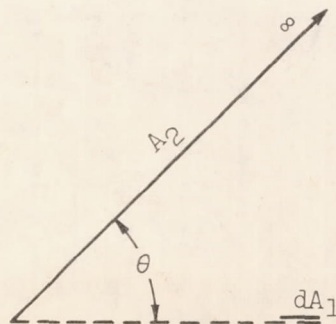
and L , where $N = a/b$ and $L = c/b$ (see sketch). (See appendix C for equation.)



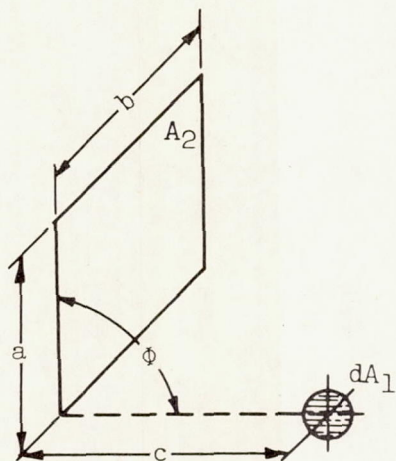
Configuration P-3: A plane point source dA_1 and any surface A_2 generated by an infinitely long line moving parallel to itself and to the plane of dA_1 . (See accompanying sketch.) The configuration-factor equation is $F_{12} = \frac{1}{2}(\cos \theta - \cos \omega)$.



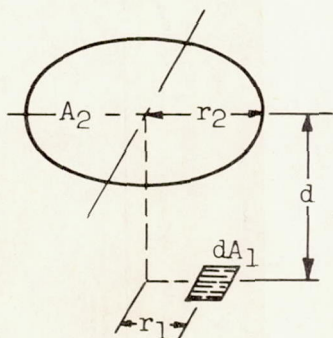
Configuration P-4: A plane point source dA_1 and any infinite plane A_2 with the planes of dA_1 and A_2 intersecting at an angle θ , as shown in the following sketch. For this configuration $F_{12} = \frac{1}{2}(1 + \cos \theta)$.



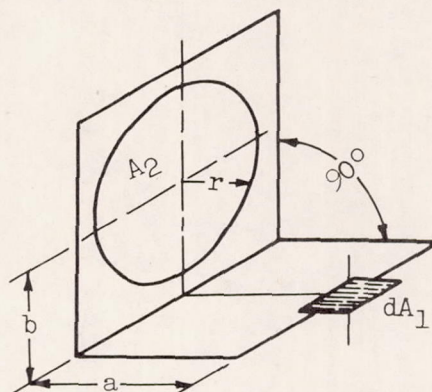
Configuration P-5: A spherical point source dA_1 and a plane rectangle A_2 ; the point source is located at one corner of a rectangle that has one common side with A_2 . The planes of the two rectangles intersect at an angle Φ (see sketch). The equation for this configuration is given in appendix C and the configuration factor F_{12} is plotted in figure 13 as a function of x and y where $x = b/c$ and $y = a/c$.



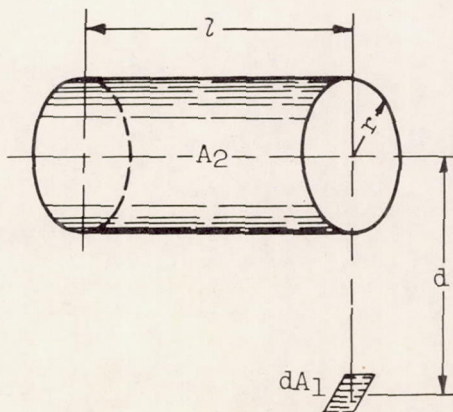
Configuration P-6: A plane point source dA_1 and a plane circular disk A_2 (see sketch). The plane of dA_1 is parallel to the plane of A_2 ; the point source is located at a distance r_1 from the normal to the center of A_2 . The configuration factor F_{12} is plotted in figure 14 for various values of E and D where $E = r_2/d$ and $D = d/r_1$. The equation for this configuration is given in appendix C and the configuration-factor values are presented in table 3.



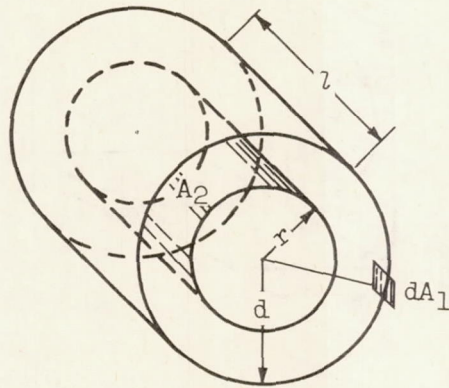
Configuration P-7: A plane point source dA_1 and a plane disk A_2 , the planes of dA_1 and A_2 intersecting at an angle of 90° . The centers of A_2 and dA_1 lie in a plane that is perpendicular to the two planes. The equation for this configuration is given in appendix C in terms of R and D for $R = r/b$ and $D = a/b$ (see sketch).



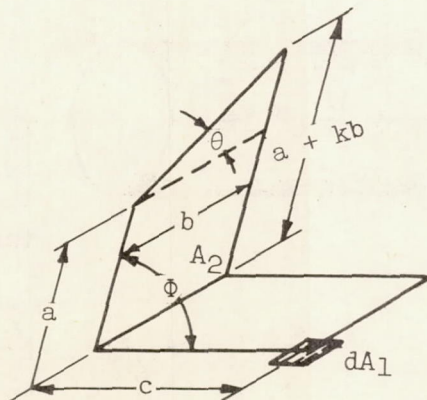
Configuration P-8: A plane point source dA_1 and a right circular cylinder A_2 of length l . The normal to dA_1 passes through the center of one end of the cylinder and is perpendicular to the axis of the cylinder (see sketch). In figure 15 the configuration factor is plotted as a function of D and L where $D = d/r$ and $L = l/r$. (See appendix C for equation and table 4 for configuration-factor values.)



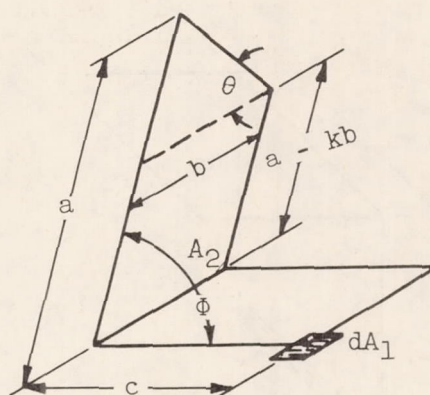
Configuration P-9: Two concentric cylinders of radius r and d and length l with a point source dA_1 on the inside of the large cylinder at one end. The configuration factor F_{11} is from the point source dA_1 on A_1 to A_1 ; A_1 does not include the ends of the annulus. The equation for F_{11} is given in appendix C in terms of D and L with $D = d/r$ and $L = l/r$ (see sketch). The configuration-factor values are given in table 5 and the curves are plotted in figure 16.



Configuration P-10: Same geometry as that of configuration P-2 with a triangular area added to the top of A_2 (see sketch). For this configuration $N = a/b$, $L = c/b$, and $\theta = \tan^{-1}(k)$. The configuration factor is plotted in figure 17 as a function of L and θ with $\phi = 90^\circ$ and $N = 0$. The equation is given in appendix C and the configuration-factor values are given in table 6.



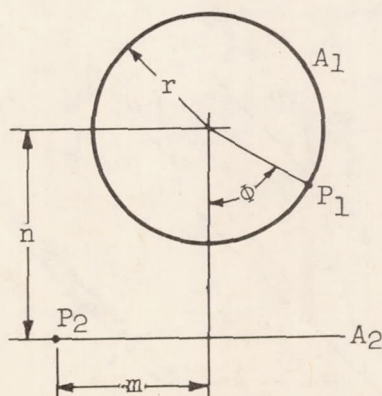
Configuration P-11: Same geometry as that of configuration P-10 with the triangle reversed, as shown in the accompanying sketch, and $N = a/b$, $L = c/b$, and $\theta = \tan^{-1}(k)$. See appendix C for equation, table 7 for values, and figure 18 for configuration-factor curves with $\phi = 90^\circ$ and $N = 0$.



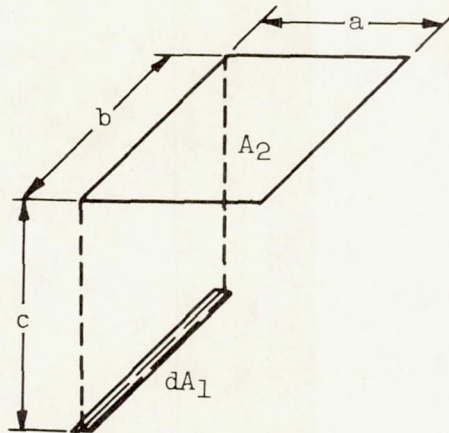
Configuration P-12: An infinitely long cylinder A_1 and an infinite plane A_2 , mutually parallel (see sketch). For this configuration $M = m/r$, $N = n/r$, and the configuration-factor equations are as follows:

$$F_{P_1-A_2} = \frac{1}{2} (1 + \cos \phi)$$

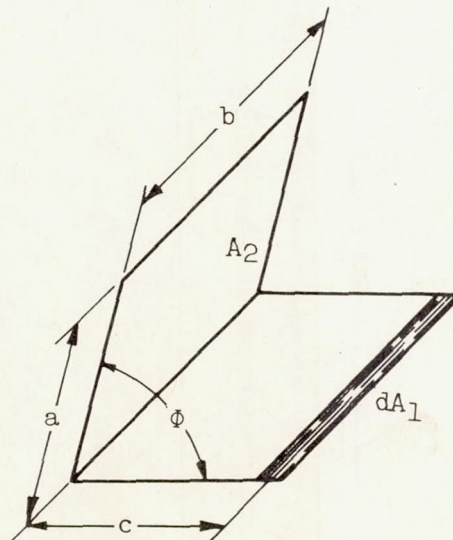
$$F_{P_2-A_1} = N / (N^2 - M^2)$$



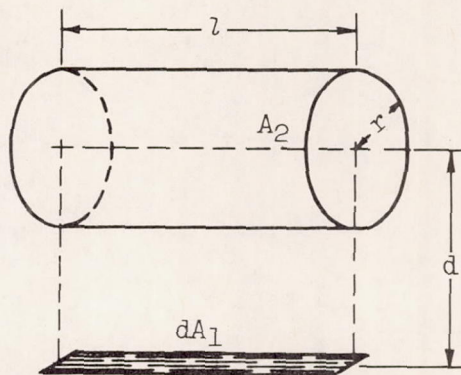
Configuration L-1: A line source dA_1 and a plane rectangle A_2 parallel to the plane of dA_1 with dA_1 opposite one edge of A_2 . The configuration-factor values are given in table 8 and the equation is presented in appendix C. Figure 19 is a plot of F_{12} as a function of x and y where $x = b/c$ and $y = a/c$ (see sketch).



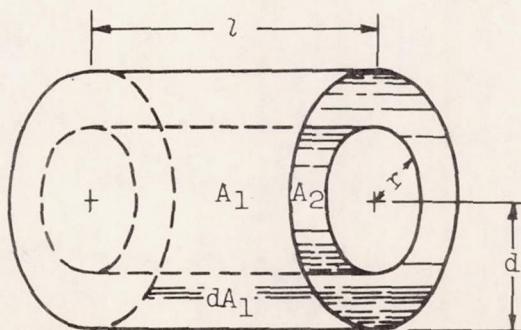
Configuration L-2: A line source dA_1 and a plane rectangle A_2 which intersects the plane of dA_1 at an angle ϕ . The configuration factor is plotted in figure 20 as a function of N and L for various values of the angle ϕ . For this configuration $N = a/b$ and $L = c/b$. (See appendix C for equation and table 9 for configuration-factor values.)



Configuration L-3: A line source dA_1 and a right circular cylinder A_2 , both of length l ; the normal through each end of the source passes through and normal to the center line of the cylinder at the ends. The configuration-factor values are given in table 10 and the curves plotted in figure 21 in terms of the parameters D and L , where $D = d/r$ and $L = l/r$ (see sketch).



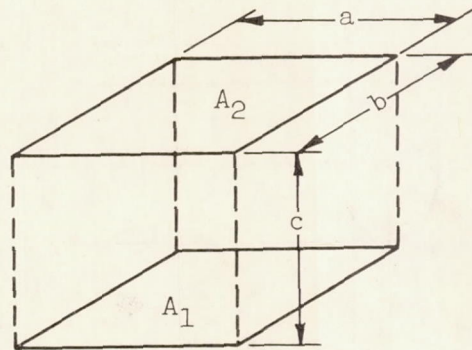
Configuration L-4: Two concentric cylinders of radius r and d and length l with a line source, or element, dA_1 on the inside of the large cylinder (see sketch). The configuration factor F_{11} is from dA_1 to A_1 . This factor is plotted in figure 22 as a function of D and L with $D = d/r$ and $L = l/r$. (See table 11 for configuration-factor values.)



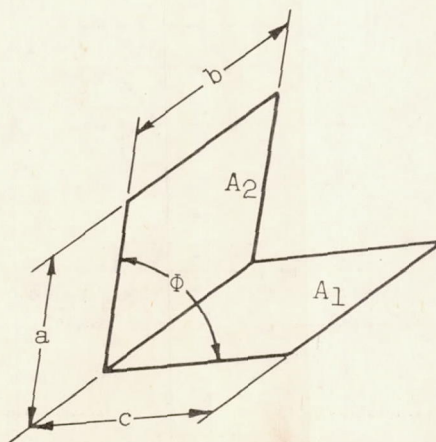
Configuration L-5: Same geometry as that of configuration L-4 (see sketch above). The configuration factor from dA_1 to either end can be obtained from figures 21 and 22 and the equation

$$F_{dA_1\text{-one end}} = \frac{1}{2}(1 - F_{11} - F_{12})$$

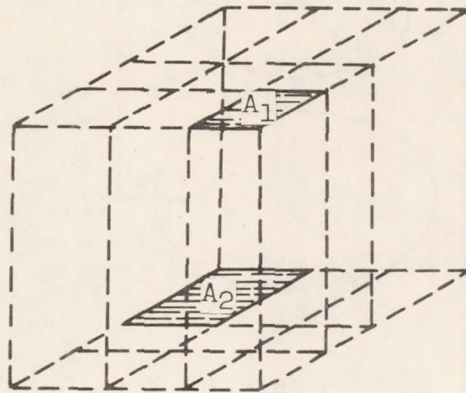
Configuration A-1: Identical, parallel, directly opposed rectangles A_1 and A_2 , as shown in the following sketch. The configuration-factor values are given in table 12 and plotted in figure 23 in terms of the parameters x and y , where $x = b/c$ and $y = a/c$. (See appendix C for equation.)



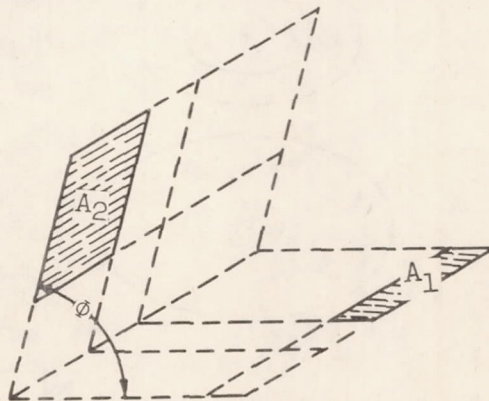
Configuration A-2: Two rectangles A_1 and A_2 with one common edge and included angle ϕ between the two planes. The configuration factor is plotted in figure 24 as a function of N and L for various values of ϕ . For this configuration $N = a/b$ and $L = c/b$ (see sketch). The equation for F_{12} is given in appendix C and the configuration-factor values are presented in table 13.



Configuration A-3: Two rectangles A_1 and A_2 in parallel planes with one edge of A_1 parallel to one edge of A_2 (see sketch). The configuration factor F_{12} can be obtained from figure 23 and configuration-factor algebra.

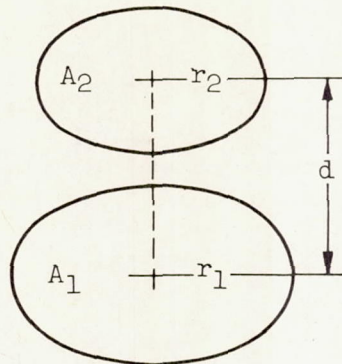


Configuration A-4: Two rectangles A_1 and A_2 with one side of A_1 parallel to one side of A_2 ; the planes of A_1 and A_2 intersect at an angle ϕ (see sketch). The configuration factor F_{12} can be obtained from figure 24 and configuration-factor algebra.



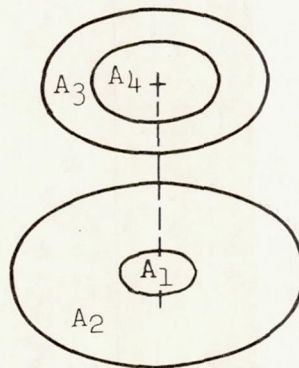
Configuration A-5: Parallel, directly opposed, plane circular disks (see sketch). For this configuration $E = r_2/d$ and $D = d/r_1$.

The values of F_{12} are given in table 14 and the curves plotted in figure 25 in terms of E and D . (See appendix C for equation.)



Configuration A-6: Same geometry as that of configuration A-5 (see also accompanying sketch). Using figure 25 and configuration-factor algebra, one can obtain F_{24} from the following equation:

$$A_2 F_{24} = (A_1 + A_2) [F_{(12)(34)} - F_{(12)4}] - A_1 [F_{1(34)} - F_{14}]$$



Configurations A-7 and A-8: Two concentric cylinders of radius r and d , respectively, and length l ; A_1 is the inside surface of the large cylinder, A_2 is the outside surface of the small cylinder, and A_3 is one of the ends of the annulus (see sketch). The factors F_{12} (configuration A-7) and F_{11} (configuration A-8) can be obtained from figures 21 and 22, respectively, with $D = d/r$ and $L = l/r$. (See

also tables 10 and 11.) The factor F_{13} is obtained from the following equation:

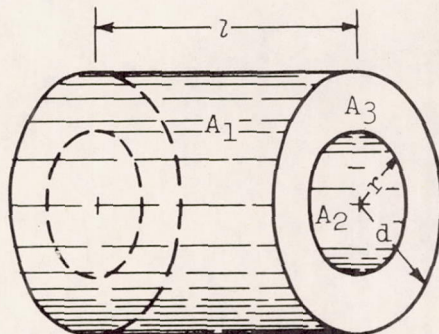
$$F_{13} = \frac{1}{2}(1 - F_{12} - F_{11})$$

All factors involved in the annulus can be obtained from figures 21 and 22, configuration-factor algebra, and the following equations:

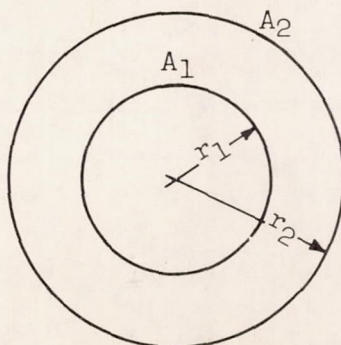
$$F_{31} = (A_1/A_3)F_{13}$$

$$\begin{aligned} F_{32} &= (A_2/A_3)F_{23} \\ &= (A_2/A_3)\frac{1}{2}(1 - F_{21}) \\ &= \frac{1}{2} \left[(A_2/A_3) - (A_1/A_3)F_{12} \right] \end{aligned}$$

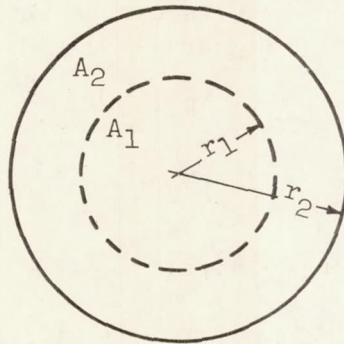
$$F_{33} = 1 - F_{31} - F_{32}$$



Configuration A-9: Two parallel, concentric cylinders A_1 and A_2 of radius r_1 and r_2 , respectively, and infinite length (see sketch) so that $F_{12} = 1$ and $F_{21} = r_1/r_2$.



Configuration A-10: Two concentric spheres A_1 and A_2 of radius r_1 and r_2 , respectively (see sketch). The configuration-factor equations are $F_{12} = 1$ and $F_{21} = (r_1/r_2)^2$.

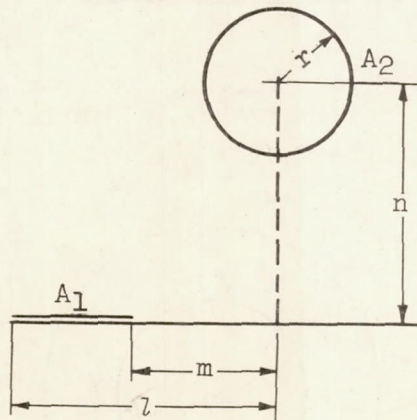


Configuration A-11: An infinite cylinder parallel to the plane of an infinitely long rectangle of width $l - m$. The configuration-factor equation is

$$F_{12} = \left[\frac{l}{L - M} \right] \tan^{-1}(L/N) - \tan^{-1}(M/N)$$

where $N = n/r$, $M = m/r$, and $L = l/r$ (see sketch). For $M = 0$,

$$F_{12} = (l/L) \tan^{-1}(L/N)$$



APPENDIX C

CONFIGURATION-FACTOR EQUATIONS

Some of the more complex configuration-factor equations are presented in this appendix. Each equation is given in terms of two or more parameters which are dimensionless ratios of significant lengths. These parameters are defined in appendix B where the configurations are described and illustrated.

Configuration P-1

$$F_{12} = \frac{1}{2\pi} \left[\frac{x}{\sqrt{1+x^2}} \tan^{-1} \left(\frac{y}{\sqrt{1+x^2}} \right) + \frac{y}{\sqrt{1+y^2}} \tan^{-1} \left(\frac{x}{\sqrt{1+y^2}} \right) \right]$$

$$\lim_{y \rightarrow \infty} F_{12} = \frac{x}{4\sqrt{1+x^2}}$$

$$\lim_{x \rightarrow \infty} F_{12} = \frac{y}{4\sqrt{1+y^2}}$$

Configuration P-2

$$\text{Let } V = \frac{1}{\sqrt{N^2 + L^2 - 2NL \cos \phi}} \text{ and } W = \sqrt{1 + L^2 \sin^2 \phi}$$

Then

$$F_{12} = \frac{1}{2\pi} \left\{ \tan^{-1} \left(\frac{1}{L} \right) + V(N \cos \phi - L) \tan^{-1} V + \frac{\cos \phi}{W} \left[\tan^{-1} \left(\frac{N - L \cos \phi}{W} \right) + \tan^{-1} \left(\frac{L \cos \phi}{W} \right) \right] \right\}$$

$$\lim_{N \rightarrow \infty} F_{12} = \frac{1}{2\pi} \left\{ \tan^{-1} \left(\frac{1}{L} \right) + \frac{\cos \phi}{W} \left[\frac{\pi}{2} + \tan^{-1} \left(\frac{L \cos \phi}{W} \right) \right] \right\}$$

$$\lim_{L \rightarrow \infty} F_{12} = 0$$

$$\lim_{L \rightarrow 0} F_{12} = \frac{1}{4} (1 + \cos \phi)$$

$$\lim_{N, L \rightarrow \infty} F_{12} = 0$$

Configuration P-5

$$F_{12} = \frac{1}{4\pi} \left\{ \tan^{-1} \left[\frac{x(y - \cos \phi)}{\sqrt{1 + x^2 + y^2 - 2y \cos \phi}} \right] + \tan^{-1} \left(\frac{x \cos \phi}{\sqrt{1 + x^2}} \right) \right\}$$

For $\phi = 90^\circ$,

$$F_{12} = \frac{1}{4\pi} \tan^{-1} \left(\frac{xy}{\sqrt{1 + x^2 + y^2}} \right)$$

$$\lim_{x \rightarrow \infty} F_{12} = \frac{1}{4\pi} \tan^{-1} y$$

$$\lim_{\substack{x \rightarrow \infty \\ y \rightarrow \infty}} F_{12} = \frac{1}{8}$$

Configuration P-6

$$F_{12} = \frac{1}{2} \left(1 - \frac{x - 2E^2D^2}{\sqrt{x^2 - 4E^2D^2}} \right)$$

where

$$x = 1 + (1 + E^2)D^2$$

Configuration P-7

$$F_{12} = \frac{D}{2} \left[\frac{1 + R^2 + D^2}{\sqrt{(1 + R^2 + D^2)^2 - 4R^2}} - 1 \right]$$

$$\lim_{R \rightarrow 1} F_{12} = \frac{1}{2} \left(\frac{D^2 + 2}{\sqrt{D^2 + 4}} - D \right)$$

Configuration P-8

$$\text{Let } A = (D + 1)^2 + L^2 \text{ and } B = (D - 1)^2 + L^2$$

Then

$$F_{12} = \frac{1}{\pi D} \tan^{-1} \left(\frac{L}{\sqrt{D^2 - 1}} \right) + \frac{L}{\pi} \left[\frac{A - 2D}{D \sqrt{AB}} \tan^{-1} \sqrt{\frac{A(D - 1)}{B(D + 1)}} - \frac{1}{D} \tan^{-1} \sqrt{\frac{D - 1}{D + 1}} \right]$$

Configuration P-9

$$F_{11} = \frac{1}{2} - \frac{1}{4D} + \frac{1}{\pi D} \left\{ L \tan^{-1} \sqrt{D^2 - 1} - \frac{1}{2} \tan^{-1} \left[\frac{L^2 - 4(D^2 - 1)}{4L \sqrt{D^2 - 1}} \right] - \left(\frac{L^2 + 2D^2}{\sqrt{L^2 + 4D^2}} \right) \tan^{-1} \left[\frac{\sqrt{(D^2 - 1)(L^2 + 4D^2)}}{L} \right] \right\}$$

Configuration P-10

Let

$$A = \sqrt{(k^2 + 1)L^2 \sin^2 \phi + (N - L \cos \phi)^2}$$

and

$$B = \sqrt{1 + L^2 \sin^2 \phi}$$

Then

$$F_{12} = \frac{1}{2\pi} \left(\tan^{-1} \left(\frac{1}{L} \right) + \frac{N \cos \phi - L}{A} \left\{ \tan^{-1} \left[\frac{(k^2 + 1) + k(N - L \cos \phi)}{A} \right] - \right. \right. \\ \left. \left. \tan^{-1} \left[\frac{k(N - L \cos \phi)}{A} \right] \right\} + \frac{\cos \phi}{B} \left[\tan^{-1} \left(\frac{L \cos \phi}{B} \right) + \right. \\ \left. \left. \tan^{-1} \left(\frac{N - L \cos \phi + k}{B} \right) \right] \right)$$

For $N = 0$ and $\phi = 90^\circ$,

$$F_{12} = \frac{1}{2\pi} \left[\tan^{-1} \left(\frac{1}{L} \right) - \frac{1}{\sqrt{k^2 + 1}} \tan^{-1} \left(\frac{\sqrt{k^2 + 1}}{L} \right) \right]$$

Configuration P-11

Let

$$A = \sqrt{(k^2 + 1)L^2 \sin^2 \phi + (N + k - L \cos \phi)^2}$$

and

$$B = \sqrt{1 + L^2 \sin^2 \phi}$$

Then

$$F_{12} = \frac{1}{2\pi} \left(\tan^{-1} \left(\frac{1}{L} \right) + \frac{\cos \phi}{B} \left[\tan^{-1} \left(\frac{N - L \cos \phi}{B} \right) + \tan^{-1} \left(\frac{L \cos \phi}{B} \right) \right] + \right. \\ \left. \frac{(N + k) \cos \phi - L}{A} \left\{ \tan^{-1} \left[\frac{1 - k(N - L \cos \phi)}{A} \right] + \right. \right. \\ \left. \left. \tan^{-1} \left[\frac{k(N + k - L \cos \phi)}{A} \right] \right\} \right)$$

For $N = 0$ and $\phi = 90^\circ$, let $C = \sqrt{L^2 + k^2(1 + L^2)}$.

Then

$$F_{12} = \frac{1}{2\pi} \left\{ \tan^{-1} \left(\frac{1}{L} \right) - \frac{L}{C} \left[\tan^{-1} \left(\frac{k^2}{C} \right) + \tan^{-1} \left(\frac{1}{C} \right) \right] \right\}$$

Configuration L-1

$$F_{12} = \frac{1}{\pi x} \left[\sqrt{1 + x^2} \tan^{-1} \left(\frac{y}{\sqrt{1 + x^2}} \right) - \tan^{-1} y + \frac{xy}{\sqrt{1 + y^2}} \tan^{-1} \left(\frac{x}{\sqrt{1 + y^2}} \right) \right]$$

$$\lim_{x \rightarrow \infty} F_{12} = \frac{y}{2\sqrt{1 + y^2}}$$

$$\lim_{y \rightarrow \infty} F_{12} = \frac{1}{2} \left(\sqrt{1 + \frac{1}{x^2}} - \frac{1}{x} \right)$$

Configuration L-2

$$F_{12} = \frac{1}{\pi} \left\{ \tan^{-1} \left(\frac{1}{L} \right) + L \frac{\sin^2 \phi}{2} \log_e \left[\frac{L^2 (L^2 - 2NL \cos \phi + 1 + N^2)}{(1 + L^2)(L^2 - 2NL \cos \phi + N^2)} \right] - \right.$$

$$L \sin \phi \cos \phi \left[\frac{\pi}{2} - \phi + \tan^{-1} \left(\frac{N - L \cos \phi}{L \sin \phi} \right) \right] +$$

$$\cos \phi \sqrt{1 + L^2 \sin^2 \phi} \left[\tan^{-1} \left(\frac{N - L \cos \phi}{\sqrt{1 + L^2 \sin^2 \phi}} \right) + \tan^{-1} \left(\frac{L \cos \phi}{\sqrt{1 + L^2 \sin^2 \phi}} \right) \right] +$$

$$\left. \frac{N \cos \phi - L}{\sqrt{L^2 - 2NL \cos \phi + N^2}} \tan^{-1} \left(\frac{1}{\sqrt{L^2 - 2NL \cos \phi + N^2}} \right) \right\}$$

$$\lim_{N \rightarrow \infty} F_{12} = \frac{1}{\pi} \tan^{-1} \left(\frac{1}{L} \right) + \frac{L \cos \phi}{\pi} \left\{ \frac{\sin^2 \phi}{2 \cos \phi} \log_e \left(\frac{L^2}{1 + L^2} \right) - \right.$$

$$\left. \sin \phi (\pi - \phi) + \frac{\sqrt{1 + L^2 \sin^2 \phi}}{L} \left[\frac{\pi}{2} + \tan^{-1} \left(\frac{L \cos \phi}{\sqrt{1 + L^2 \sin^2 \phi}} \right) \right] \right\}$$

$$\lim_{L \rightarrow \infty} F_{12} = 0$$

$$\lim_{L \rightarrow 0} F_{12} = \frac{1}{2} (1 + \cos \phi)$$

$$\lim_{N \rightarrow 0} F_{12} = 0$$

Configuration A-1

$$F_{12} = \frac{2}{\pi xy} \left\{ \log_e \left[\frac{(1+x^2)(1+y^2)}{1+x^2+y^2} \right]^{1/2} + y\sqrt{1+x^2} \tan^{-1} \left(\frac{y}{\sqrt{1+x^2}} \right) + \right. \\ \left. x\sqrt{1+y^2} \tan^{-1} \left(\frac{x}{\sqrt{1+y^2}} \right) - y \tan^{-1} y - x \tan^{-1} x \right\}$$

$$\lim_{x \rightarrow \infty} F_{12} = \sqrt{1 + \frac{1}{y^2}} - \frac{1}{y}$$

$$\lim_{y \rightarrow \infty} F_{12} = \sqrt{1 + \frac{1}{x^2}} - \frac{1}{x}$$

$$\lim_{\substack{x \rightarrow \infty \\ y \rightarrow \infty}} F_{12} = 1$$

Configuration A-2

For $\phi = 90^\circ$,

$$F_{12} = \frac{1}{\pi L} \left(L \tan^{-1} \left(\frac{1}{L} \right) + N \tan^{-1} \left(\frac{1}{N} \right) - \sqrt{N^2 + L^2} \tan^{-1} \left(\frac{1}{\sqrt{N^2 + L^2}} \right) + \right.$$

$$\left. \frac{1}{4} \log_e \left\{ \left[\frac{(1+L^2)(1+N^2)}{(1+N^2+L^2)} \right] \left[\frac{L^2(1+L^2+N^2)}{(1+L^2)(L^2+N^2)} \right]^{L^2} \left[\frac{N^2(1+L^2+N^2)}{(1+N^2)(L^2+N^2)} \right]^{N^2} \right\} \right)$$

$$\lim_{L \rightarrow \infty} F_{12} = 0$$

$$\lim_{N \rightarrow \infty} F_{12} = \frac{1}{\pi} \left[\tan^{-1} \left(\frac{1}{L} \right) + \frac{1}{4L} \log_e (1 + L^2) - \frac{L}{4} \log_e \left(\frac{1 + L^2}{L^2} \right) \right]$$

Configuration A-5

$$F_{12} = \frac{1}{2} \left(x - \sqrt{x^2 - 4E^2D^2} \right)$$

where

$$x = 1 + (1 + E^2)D^2$$

APPENDIX D

ANALYSIS OF RADIATION TO THE ROTOR BLADES
OF A GAS TURBINE

An approximate analysis is given of the net radiant heat transfer to the rotor blades of a gas turbine under different conditions of temperature and pressure. The rotor blades were postulated to be at a temperature of 900° F for the entire analysis. The analysis indicates that at the lower gas temperature, 1600° F, radiation is apparently negligible compared with convection, whereas at the higher gas temperature, 2500° F, the relative effect of radiation is still not great but is no longer negligible.

The postulates upon which this analysis is based were established in a conference with Messrs. H. H. Ellerbrock and Jack B. Esgar and Drs. E. R. G. Eckert and Thomas W. Jackson of the NACA Lewis Flight Propulsion Laboratory.

Introduction

At the present operating gas temperatures the heat transfer to the rotor blades of an aircraft gas turbine due to radiation is not appreciable compared with that due to convection. There are many advantages to be gained from operating at higher gas temperatures and, if cooled nonstrategic metals are to be used, it is desirable to know the effect of radiation at those temperatures. Since the rotor blades are the most critical item in cooling a gas turbine, it was decided that the available time could be most profitably spent by confining the analysis to the rotor blades and their radiant environment.

The convective-heat-transfer coefficient h_c is defined by

$$h_c = q/A(T_{g,e} - T_b)$$

where $T_{g,e}$ is the effective gas temperature and T_b , the rotor-blade surface temperature. (See appendix A for definitions of all symbols.) The effective gas temperature is a function of the recovery factor and, depending on whether one wishes to use the data for component design or for correlating basic heat-transfer data, one of three recovery

factors may be employed - each of which gives a different value for h_c . The results of this analysis are given in the form of an equivalent radiant-heat-transfer coefficient h_r . The total temperature of the gas in the combustion chamber was used as the effective gas temperature. The reader can convert the h_r values given to more accurate ones by multiplying by the ratio of the temperature difference used herein to the temperature difference containing the recovery factor of interest to him.

Definition of System

Geometry.- The system to be analyzed is an idealization of the J-35 gas turbine as depicted in figures 26 to 29. The stator-blade system was postulated to be geometrically similar to the rotor-blade system since drawings of stator blades were not available. Two analyses were made, as follows:

(a) Radial analysis on a line source (the line being radial or parallel to the length of the rotor blade and tangential on the hub and shroud of the blade). The point configuration factors (for points indicated in fig. 28) were obtained from the curves of this report for points along each line source; then the mean configuration factor for each line source was determined by numerical integration. After the line configuration factors were obtained (see fig. 30), these values were associated with lines on a system of rotor blades in which the cross section was identical with section C-C (fig. 28) from blade root to blade shroud. This geometry was used for the analysis resulting in figure 31.

(b) Gross analysis of radiation to the rotor blades in which the blade system was represented by an equivalent blade area described by constructing a solid ring of width equal to the blade length and of thickness equal to the blade thickness. The "ring" construction was also used in the case of the stator-blade system. The effective emissivity of these equivalent areas will be described later. The various mean configuration factors were obtained from figures 21 and 22.

Numerical integration of figure 30 gives the following values: $F_{b-s} = 0.15$, $F_{b-t} = 0.19$, and $F_{b-b} = 0.66$. The mean configuration factors for the gross analysis as obtained from the curves are $F_{b,e-s} = 0.84$ and $F_{b,e-t} = 1$. Other pertinent facts related to the geometry are: Blade length, 3.55 inches; blade circumference, 16.15 inches; actual blade area A_b , 19 square inches; and effective blade area, 2.7 square inches.

Surface emissivities.- All metal surfaces were postulated to be gray with an emissivity of 0.7 (reference 1). In the case where the stator blades were postulated to be ceramic an emissivity of 0.9 was used.

The effective emissivity $e_{1,e}$ of a surface A_1 which, because of asperities, or systematic grooves, in the surface, can "see" itself and has an actual area greater than its effective area as viewed from a distance is given by:

$$e_{1,e} = \frac{e_1}{1 - (1 - e_1)F_{11}}$$

where e_1 is the emissivity of the smooth surface. This equation is not valid for large angles from the normal to $A_{1,e}$ or for asperities in which each point cannot "see" all other points on the asperity. The blade system can be considered as a coarsely rough surface, but the above equation does not apply. A more detailed analysis reveals that the equivalent area of the blade system with an e_1 of 0.7 has the radiating characteristics of a gray surface with an e of 0.85, transmitting (by multiple reflection) about 0.1 and reflecting about 0.05. For an e_1 of 0.9 the value of $e_{1,e}$ is 0.95.

Gas geometry.- The "mean beam length" or equivalent hemisphere radius was computed by the formula (reference 32)

$$L = 3.6V/A$$

where V is the gas volume, A , the surface area, and L , the mean beam length.

Description of system.- The temperature and pressure conditions and the composition of the products of combustion for the radiation analysis were as follows:

Condition	I	II
Gas temperature in combustion chamber, °F	1600	2500
Gas temperature in tail cone, °F	1200	1800
Gas temperature in tail cone with afterburner operating, °F	3500	3500
Water in combustion products, percent	3.1	7.0
Water in combustion products with afterburner operating, percent	12.6	14.0
Carbon dioxide in combustion products, percent	2.8	6.2
Carbon dioxide in combustion products with afterburner operating, percent	11.3	12.5
Carbon monoxide in combustion products, percent	0	0
Pressure in tail cone, in. Hg abs.	60	165
Rotor-blade temperature, °F	900	900
Tail-cone surface temperature, °F	1000	1600
Stator-blade temperature, °F	1200	1200
Turbine-wheel-casing temperature, °F	1100	1500

These conditions were also varied slightly as follows:

- (1) Condition Ia: Same as condition I except that the stator-blade temperature was changed to 1600° F
- (2) Condition IIa: Same as condition II except for the following changes:
 - (a) Stator material was ceramic with an effective emissivity of equivalent stator-blade area of 0.95
 - (b) Stator-blade temperature changed to 2500° F

Discussion of Analysis

Because of the excess air the combustion efficiency in an aircraft gas turbine is 90 percent or greater (reference 33) so that, in the present report, the products of combustion were postulated to be non-luminous and to contain a negligible amount of carbon monoxide. Gas radiation from the space between the rotor blades and from the space between the rotor blades and the stator blades was neglected because of the small dimensions. In the determination of the composition of the products of combustion the effect of heat loss from the combustion-chamber area was neglected. For this reason the percent of radiating constituents postulated was probably too small.

Excellent treatments of presently available methods of calculating radiant interchange are given in references 1 to 3. The reader is

invited to consult these references for the details of radiant interchange. Only a summary of the equations used will be given.

The gas-radiation calculations are no doubt in error because of the use of data valid only for a total pressure of 1 atmosphere. There is need for such data at higher total pressures as well as for similar data for luminous flames such as occur in the combustion chamber of a gas turbine. Some luminous-flame data are available (references 34 to 36); however, they are not strictly applicable to the present problem.

In the gross analysis of the blade using the effective blade area and emissivity, equation (D1) is applicable:

$$\begin{aligned}
 h_{r,m} = \sigma \frac{A_{b,e}}{A_b} \frac{1}{(T_{g,e} - T_b)} & \left[\left(T_{g,t}^4 - \frac{\alpha_{g,t}}{e_{g,t}} T_b^4 \right) f_{g-b,e} + \right. \\
 & \left(T_t^4 - T_b^4 \right) f_{t-b,e} + \left(T_c^4 - T_b^4 \right) f_{c-b,e} \left(\frac{A_{sh}}{A_{b,e}} \right) + \\
 & \left. \left(T_{g,t,ab}^4 - \frac{\alpha_{g,ab}}{e_{g,ab}} T_b^4 \right) f_{g,t,ab-b,e} + \left(T_s^4 - T_b^4 \right) f_{s-b,e} \right] \quad (D1)
 \end{aligned}$$

where

$$f_{g-b,e} = \frac{1 + (1 - F_{tt})(1 - e_t)(1 - e_{g,t})}{1 - (1 - e_t)(1 - e_{g,t})F_{tt}}$$

$$f_{t-b,e} = \frac{e_{b,e} e_t (1 - \alpha_{g,t})}{1 - (1 - \alpha_{g,t})(1 - e_t)F_{tt}}$$

$$f_{s-b,e} = e_{s,e} e_{b,e} F_{b,e-s}$$

$$f_{c-b,e} = \frac{1}{\frac{1}{e_c} + \frac{1}{e_{b,e}} - 1}$$

$$f_{g,t,ab-b,e} = e_{g,t,ab} e_{b,e} \alpha_{g,t} \left[F_{b,e-g,t,ab} + \frac{(1 - e_t)(1 - F_{b,e-g,t,ab}) F_{t-g,t,ab}}{1 - (1 - e_t) \alpha_{g,t} F_{tt}} \right]$$

The radial analysis on a line source along the blade (see fig. 31) was computed from the following equation (equation (D2)). Equations (D1) and (D2) may be derived by tracing the history of a ray emitted from the source or sink involved.

$$h_{r,x} = \frac{\sigma e_x}{(T_{g,e}^4 - T_b^4)} \left\{ (T_s^4 - T_x^4) e_{s,e} \left[F_{x-s} + \frac{F_{x-b} F_{b-s} (1 - e_b)}{1 - (1 - e_b) F_{b-b}} \right] + (T_t^4 - T_x^4) \alpha_t \left[F_{x-t} + \frac{F_{x-b} F_{b-t} (1 - e_b)}{1 - (1 - e_b) F_{b-b}} \right] f_{t-b,e} + \left(T_{g,t}^4 - \frac{\alpha_{g,t}}{e_{g,t}} T_x^4 \right) e_{g,t} \left[F_{x-t} + \frac{F_{x-b} F_{b-t} (1 - e_b)}{1 - (1 - e_b) F_{b-b}} \right] f_{g,t-b,e} \right\} \quad (D2)$$

In equation (D2) the effect of afterburning was neglected; this analysis was used only for condition I to obtain an approximation for the distribution of radiant flux over the blade. The numerical integration of this result over the blade surface added to the net flux between the blade shroud and the casing agreed with the same calculation by the gross-analysis method to within 10 percent.

Results

The results of the analysis are presented in the following table:

Condition	Heat flux to rotor blades from sources indicated (Btu/(hr)(sq ft of blade)					Radiant-heat-transfer coefficient, h_r
	Tail-cone gases	Tail-cone surface	Stator blades	Turbine wheel casing	Afterburner gases	
I	40	265	625	435	120	2.1
Ia	40	265	2,210	435	120	4.4
II	340	2050	625	2080	610	3.6
IIa	340	2050	16,500	2080	610	13.5

The effective gas temperature used in computing h_r was 1600° F for condition I and 2500° F for condition II.

Discussion of Results

The effect of the radiating gases in the tail cone is to absorb slightly more of the lower-temperature radiation from the tail-cone surface to the blades than the gas emits to the blade. Thus, if the gas radiation had been neglected the results would have been almost the same. This indicates that, for a given gas temperature, at still higher altitudes the convection would decrease but radiation would increase slightly.

The analysis corresponds to a gas turbine with a compression ratio of 10 operating at sea level with a combustion gas temperature of 2500° F (conditions II and IIa) and operating at 25,000 feet with a combustion gas temperature of 1600° F (conditions I and Ia).

It is interesting to note in figure 31 that, in order to eliminate the tendency for a "hot spot" at the leading edge of the rotor blade, a wedge or sharp leading-edge profile would be required. This is in opposition to the accepted procedure of increasing the radius of curvature of the leading edge to suppress a hot spot due to convection.

The effect of the afterburning on the heat flux to the rotor blades was smaller than expected. This was due mainly to the large distance (1 ft) from the blade area to the beginning of the afterburning.

REFERENCES

1. Eckert, Ernst: Introduction to the Transfer of Heat and Mass. First ed., McGraw-Hill Book Co., Inc., 1950.
2. Jakob, M., and Hawkins, G. A.: Elements of Heat Transfer and Insulation. Second ed., John Wiley & Sons, Inc., 1950.
3. McAdams, William H.: Heat Transmission. Second ed., McGraw-Hill Book Co., Inc., 1942.
4. Christiansen, C.: Absolute Bestimmung des Emissions- und Absorptionsvermögens für Wärme. Weidemann Ann., Folge 3, Bd. 19, Heft 6, May 1, 1883, pp. 267-283.
5. Nusselt, Wilhelm: Graphische Bestimmung des Winkelverhältnisses bei der Wärmestrahlung. Z.V.D.I., Bd. 72, Nr. 20, May 19, 1928, p. 673.
6. Kalous, K.: Allgemeine Theorie der Strahlungsheizung. Forsch. Geb. Ing.-Wes., Bd. 8, Nr. 4, July/Aug. 1937, pp. 170-183.
7. Gröber, H., and Erk, S.: Die Grundgesetze der Wärmeübertragung. Julius Springer (Berlin), 1933.
8. Ten Bosch, M.: Die Wärmeübertragung. Julius Springer (Berlin), 1936.
9. Gerbel, M.: Die Grundgesetze der Wärmestrahlung. Julius Springer (Berlin), 1917.
10. Eucken, A., and Jakob, M.: Der chemie Ingenieur. Vol. I. Akademische Verlags G.m.b.H. (Leipzig), 1933.
11. Squassi, F.: Der Wärmeaustausch zwischen den Raumwänden. Gesundheits-Ing., Bd. 63, Nr. 4, Jan. 1940, pp. 37-42.
12. Van der Held, M.: Wärmeübertragung durch Strahlung. Gesundheits-Ing., Bd. 62, Nr. 40, Oct. 1939, pp. 581-585, 594-598.
13. Van der Held, M.: Wärmeübertragung durch Strahlung bei Deckenheizung. Gesundheits-Ing., Bd. 62, Nr. 6, Feb. 1939, pp. 73-76.
14. Yamauti, Z.: Geometrical Calculation of Illumination. Researches, Tokyo Electrotech. Lab., no. 148, 1924.
15. Yamauti, Z.: Further Study of Geometrical Calculation of Illumination. Researches, Tokyo Electrotech. Lab., no. 194, 1927.

16. Higbie, H. H.: *Lighting Calculations*. John Wiley & Sons, Inc., 1934.
17. Higbie, H. H., and Randall, W. C.: *Designing Buildings for Day-lighting*. *Trans. A.S.M.E.*, MAN-51-8, vol. 51, no. 9, Jan. 1929, pp. 61-75.
18. Moon, P.: *Scientific Basis for Illuminating Engineering*. McGraw-Hill Book Co., Inc., 1936.
19. Mackay, C. O., Wright, L. T., Jr., Clark, R. E., and Gay, N. R.: *Radiant Heating and Cooling*. Part I. *Bull. No. 32, Eng. Exp. Station, Cornell Univ.*, Aug. 1943.
20. Hyde, E. P.: *Talbot's Law as Applied to the Rotating Sector Disk*. *Bull., Bur. Standards*, vol. 2, no. 1, 1906, pp. 1-33.
21. Chessin, A. S.: *On an Integral Appearing in Photometry*. *Bull. No. 14, Am. Math. Soc.*, 1908, pp. 212-215.
22. Hausen, H.: *Die Messung von Lufttemperaturen in geschlossenen Räumen mit nicht strahlungsgeschützten Thermometern*. *Zeitschr. tech. Phys.*, Bd. 5, Nr. 5, May 1924, pp. 169-186.
23. Seibert, O.: *Die Wärmeaufnahme der bestrahlten Kesselheizfläche*. *Forschungsheft 324, Forsch.-Arb. Geb. Ing.-Wes.*, 1930. (Abstracted in *Archiv Wärmewirtschaft und Dampfkesselwesen*, Bd. 9, Nr. 6, 1928, pp. 180-188, and in *Wärme*, Bd. 53, Nr. 28, July 1930, pp. 537-543.)
24. Roszak, C., and Véron, M.: *Thermal Radiation from the Standpoint of Industrial Application*. Parts I to III. *Rev. métallurgie*, vol. 21, no. 8, Aug. 1924, pp. 435-449; vol. 21, no. 9, Sept. 1924, pp. 549-564; vol. 21, no. 10, Oct. 1924, pp. 600-609.
25. Eckert, E.: *Technische Strahlungsaustauschrechnungen und ihre Anwendung in der Beleuchtungstechnik und beim Wärmeaustausch*. VDI Verlag G.m.b.H. (Berlin), 1937.
26. Lambert, Johann H.: *Photometria*. (Augsburg), 1760.
27. Eckert, E.: *Bestimmung des Winkelverhältnisses beim Strahlungsaustausch durch das Lichtbild*. *Z.V.D.I.*, Bd. 79, Nr. 50, Dec. 14, 1935, pp. 1495-1496.
28. Hottel, H. C.: *Radiant Heat Transmission*. *Mech. Eng.*, vol. 52, no. 7, July 1930, pp. 699-704.

29. Cherry, V. H., Davis, D. D., and Boelter, L. M. K.: A Mechanical Integrator for Determination of Illumination from Diffuse Surface Sources. *Trans. Illuminating Eng. Soc.*, vol. 34, no. 9, Nov. 1939, pp. 1085-1092.
30. Jakob, Max, and Hawkins, G. A.: A Model Method of Photographic and Photometric Determination of Heat Radiation between Surfaces and through Absorbing Gases. *Jour. Appl. Phys.*, vol. 13, no. 4, April 1942, pp. 246-254.
31. England, Fred, and Croft, H. O.: Radiation Configuration Factors Using Light in Furnace Models. *Trans. A.S.M.E.*, vol. 64, no. 7, Oct. 1942, pp. 691-702.
32. Port, F. M.: Heat Transmission by Radiation from Gases. Sc. D. Thesis, M.I.T., 1939.
33. Godsey, F. W., Jr., and Young, L. A.: Gas Turbines for Aircraft. McGraw-Hill Book Co., Inc., 1949.
34. Wohlenberg, W. J.: Heat Transfer by Radiation. Res. Ser. No. 75, *Eng. Bull.*, Purdue Univ., vol. 24, no. 4a, Aug. 1940.
35. Sherman, R. A.: Radiation from Luminous and Nonluminous Natural-Gas Flames. *Trans. A.S.M.E.*, vol. 56, no. 3, March 1934, pp. 177-185.
36. Trinks, W., and Keller, J. D.: Tests of Radiation from Luminous Flames. *Trans. A.S.M.E.*, vol. 58, no. 3, April 1936, pp. 203-210.

TABLE I

VALUES OF CONFIGURATION FACTOR P-1

$\begin{matrix} y \\ x \end{matrix}$	0.1	0.2	0.4	0.6	1.0	2.0	4.0	6.0	10.0	20.0	∞
0.1	0.00314	0.00616	0.01147	0.01553	0.02034	0.02386	0.02472	0.02483	0.02487	0.02487	0.02488
.2	.00616	.01209	.02252	.03051	.04002	.04701	.04872	.04893	.04901	.04903	.04903
.4	.01147	.02252	.04204	.05710	.07525	.08885	.09223	.09266	.09281	.09284	.09285
.6	.01553	.03051	.05710	.07782	.10320	.12272	.12771	.12834	.12856	.12862	.12862
1.0	.02034	.04002	.07525	.10320	.13853	.16738	.17527	.17631	.17667	.17676	.17678
2.0	.02386	.04701	.08885	.12272	.16738	.20776	.22078	.22269	.22340	.22358	.22361
4.0	.02472	.04872	.09223	.12771	.17527	.22078	.23786	.24089	.24214	.24248	.24254
6.0	.02483	.04893	.09226	.12834	.17631	.22269	.24089	.24445	.24604	.24652	.24660
10.0	.02487	.04901	.09281	.12856	.17667	.22340	.24214	.24604	.24797	.24864	.24876
20.0	.02487	.04903	.09284	.12862	.17676	.22358	.24248	.24652	.24864	.24949	.24969
∞	.02488	.04903	.09285	.12862	.17678	.22361	.24254	.24660	.24876	.24969	.25000

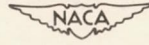


TABLE 2
VALUES OF CONFIGURATION FACTOR P-2

N L	0.05	0.1	0.2	0.4	0.6	1.0	2.0	4.0	6.0	10.0	20.0	∞
$\phi = 30^\circ$												
0		0.4665	0.4665	0.4665	0.4665	0.4665	0.4665	0.4665	0.4665	0.4665	0.4665	0.4665
.05		.3976	.4443	.4498	.4606	.4628	.4640	.4641	.4644	.4644	.4644	.4644
.1		.1853	.3649	.4439	.4480	.4584	.4596	.4620	.4621	.4622	.4622	.4622
.2		.0212	.1852	.3972	.4313	.4367	.4550	.4569	.4571	.4572	.4573	.4574
.4		.0031	.0211	.1845	.3408	.4161	.4401	.4448	.4455	.4458	.4460	.4460
.6			.0063	.0526	.1828	.3608	.4210	.4302	.4315	.4320	.4322	.4323
1.0			.0015	.0098	.0350	.1759	.3450	.3954	.3982	.3990	.3996	.3999
2.0				.0011	.0031	.0150	.1468	.2949	.3081	.3100	.3130	.3132
4.0						.0011	.0089	.0964	.1705	.1927	.1966	.1973
6.0							.0017	.0176	.0689	.1270	.1381	.1394
10.0								.0018	.0074	.0438	.0796	.0864
20.0									.0066	.0219	.0438	.0438
$\phi = 60^\circ$												
0		0.3750	0.3750	0.3750	0.3750	0.3750	0.3750	0.3750	0.3750	0.3750	0.3750	0.3750
.05		.2500	.3193	.3491	.3579	.3640	.3675	.3686	.3688	.3689	.3689	.3689
.1		.1250	.2498	.3187	.3386	.3521	.3596	.3618	.3623	.3625	.3626	.3626
.2		.0334	.1247	.2488	.2948	.3263	.3432	.3479	.3488	.3492	.3494	.3494
.4		.0072	.0330	.1228	.1981	.2678	.3076	.3183	.3202	.3211	.3215	.3216
.6		.0029	.0131	.0582	.1187	.2060	.2703	.2880	.2910	.2925	.2931	.2933
1.0			.0038	.0175	.0422	.1060	.1978	.2314	.2372	.2399	.2408	.2412
2.0				.0026	.0064	.0201	.0738	.1314	.1452	.1517	.1541	.1548
4.0						.0024	.0114	.0419	.0630	.0776	.0833	.0848
6.0							.0032	.0144	.0286	.0458	.0551	.0577
10.0								.0029	.0070	.0174	.0301	.0350
20.0									.0024	.0088	.0301	.0350
$\phi = 90^\circ$												
0	0.25000	0.25000	0.25000	0.25000	0.25000	0.25000	0.25000	0.25000	0.25000	0.25000	0.25000	0.25000
.02	.15715	.20096	.22508	.23736	.24136	.24432	.24608	.24662	.24673	.24679	.24681	.24682
.05	.07322	.13817	.18926	.21860	.22845	.23581	.24021	.24156	.24183	.24197	.24203	.24205
.1	.02638	.07317	.13799	.18860	.20734	.22174	.23046	.23316	.23370	.23398	.23410	.23414
.2	.00744	.02629	.07283	.13671	.16791	.19433	.21127	.21664	.21771	.21827	.21850	.21858
.4	.00189	.00729	.02570	.07060	.10592	.14521	.17521	.18558	.18770	.18881	.18928	.18944
.6	.00081	.00318	.01197	.03871	.06640	.10595	.14356	.15827	.16139	.16304	.16375	.16399
1.0	.00026	.00101	.00396	.01442	.02826	.05571	.09507	.11582	.12074	.12343	.12460	.12500
2.0				.00265	.00571	.01393	.03555	.05813	.06590	.07074	.07300	.07379
4.0						.00225	.00767	.01930	.02682	.03352	.03746	.03899
6.0							.00261	.00804	.01308	.01928	.02410	.02628
10.0								.00218	.00419	.00792	.01263	.01586
20.0									.00159	.00397	.00795	.00795
$\phi = 120^\circ$												
0		0.1250	0.1250	0.1250	0.1250	0.1250	0.1250	0.1250	0.1250	0.1250	0.1250	0.1250
.05		.0608	.0861	.1033	.1096	.1146	.1178	.1188	.1190	.1191	.1191	.1191
.1		.0335	.0609	.0853	.0964	.1052	.1110	.1128	.1132	.1134	.1135	.1135
.2		.0137	.0332	.0600	.0745	.0883	.0982	.1017	.1025	.1028	.1030	.1031
.4		.0044	.0133	.0318	.0457	.0623	.0769	.0828	.0842	.0849	.0852	.0854
.6		.0020	.0067	.0184	.0292	.0443	.0603	.0679	.0697	.0708	.0713	.0714
1.0			.0024	.0076	.0134	.0236	.0380	.0471	.0496	.0512	.0520	.0522
2.0				.0016	.0031	.0067	.0144	.0224	.0256	.0280	.0292	.0298
4.0						.0013	.0036	.0077	.0102	.0128	.0146	.0155
6.0							.0014	.0035	.0052	.0073	.0092	.0104
10.0								.0011	.0019	.0031	.0048	.0063
20.0									.0019	.0031	.0048	.0063
$\phi = 150^\circ$												
0		0.0335	0.0335	0.0335	0.0335	0.0335	0.0335	0.0335	0.0335	0.0335	0.0335	0.0335
.05		.0150	.0216	.0267	.0284	.0300	.0311	.0312	.0315	.0315	.0315	.0316
.1		.0086	.0152	.0217	.0246	.0272	.0289	.0296	.0297	.0297	.0298	.0298
.2		.0037	.0084	.0149	.0186	.0222	.0251	.0261	.0263	.0263	.0265	.0265
.4		.0013	.0036	.0080	.0113	.0152	.0190	.0206	.0210	.0213	.0214	.0214
.6			.0019	.0047	.0072	.0107	.0145	.0165	.0171	.0174	.0176	.0176
1.0				.0020	.0034	.0057	.0090	.0112	.0118	.0123	.0124	.0126
2.0						.0017	.0034	.0052	.0059	.0065	.0069	.0070
4.0								.0018	.0024	.0029	.0034	.0036
6.0									.0012	.0017	.0022	.0024
10.0										.0011	.0011	.0015

TABLE 3

VALUES OF CONFIGURATION FACTOR P-6

E D	0.1	0.2	0.3	0.4	0.5	0.6	0.8	1.0	2.0	3.0	4.0	5.0	6.0	8.0	10.0
0.1	0	0.00001	0.00001	0.00002	0.00002	0.00004	0.00007	0.0001	0.0004	0.001	0.002	0.004	0.008	0.041	0.475
.15	-----	-----	-----	-----	-----	-----	-----	-----	.002	.007	.018	.051	.191	.879	.969
.2	.00002	.0001	.0001	.0002	.0004	.0005	.001	.002	.008	.029	.110	.450	.820	.961	.983
.3	-----	-----	-----	-----	-----	-----	-----	-----	.052	.270	.719	.895	.947	.978	.988
.4	.0002	.001	.002	.003	.005	.007	.014	.024	.185	.640	.869	.936	.961	.981	.989
.6	-----	-----	.006	.012	.019	.028	.055	.094	.528	.828	.918	.952	.969	.983	.990
.8	-----	-----	-----	-----	-----	-----	-----	-----	.669	.866	.930	.957	.971	.984	.990
1.0	.002	.010	.023	.041	.066	.096	.176	.276	.724	.880	.934	.959	.972	.984	.990
2.0	-----	-----	.056	.097	.146	.202	.322	.438	.783	.895	.940	.961	.973	.984	.990
5.0	.009	.036	.077	.130	.190	.254	.379	.490	.797	.899	.941	.961	.973	.985	.990
10.0	.010	.038	.081	.136	.197	.262	.387	.498	.799	.900	.941	.962	.973	.985	.990
20.0	.010	.038	.082	.137	.199	.264	.390	.499	.800	.900	.941	.962	.973	.985	.990
∞	.010	.038	.083	.138	.200	.265	.390	.500	.800	.900	.941	.962	.973	.985	.990



TABLE 4
VALUES OF CONFIGURATION FACTOR P-8

D L	1.1	1.2	1.3	1.4	1.5	1.6	1.7	1.8	2.0	2.5
0.1	0.33074	0.19635	0.13049	0.09428	0.07200	0.05715	0.04667	0.03895	0.02847	0.01556
.2	.41545	.30835	.22761	.17305	.13584	.10959	.09042	.07599	.05603	.03089
.3	.43824	.36015	.28808	.23070	.18715	.15426	.12913	.10962	.08186	.04577
.4	.44640	.38463	.32357	.26998	.22578	.19023	.16181	.13899	.10542	.06000
.5	.44995	.39712	.34452	.29607	.25384	.21816	.18846	.16385	.12639	.07343
.6	.45173	.40401	.35727	.31343	.27395	.23942	.20973	.18443	.14471	.08596
.7	.45270	.40807	.36531	.32514	.28837	.25545	.22648	.20123	.16046	.09753
.8	.45328	.41059	.37058	.33321	.29877	.26754	.23959	.21481	.17385	.10811
1.0	.45387	.41333	.37661	.34295	.31201	.28369	.25791	.23457	.19468	.12636
1.2	.45415	.41466	.37968	.34815	.31947	.29326	.26930	.24742	.20934	.14105
1.4	.45429	.41537	.38137	.35114	.32390	.29916	.27658	.25592	.21967	.15270
1.6	.45437	.41578	.38238	.35295	.32667	.30294	.28137	.26166	.22699	.16186
1.8	.45443	.41604	.38301	.35411	.32847	.30545	.28461	.26563	.23227	.16906
2.0	.45446	.41620	.38343	.35489	.32968	.30717	.28687	.26843	.23612	.17472
2.5	.45450	.41643	.38399	.35595	.33138	.30960	.29013	.27255	.24200	.18422
3.0	.45452	.41653	.38425	.35644	.33217	.31077	.29171	.27460	.24503	.18968
4.0	.45453	.41661	.38446	.35684	.33283	.31174	.29306	.27636	.24774	.19501
6.0	.45454	.41165	.38457	.35705	.33318	.31227	.29379	.27734	.24929	.19835
8.0	.45454	.41666	.38460	.35710	.33327	.31240	.29398	.27759	.24970	.19928
10.0	.45454	.41666	.38461	.35712	.33330	.31245	.29405	.27768	.24984	.19962
20.0	.45455	.41667	.38461	.35714	.33333	.31249	.29411	.27777	.24998	.19995
40.0	.45455	.41667	.38461	.35714	.33333	.31250	.29412	.27778	.25000	.19999
∞	.45455	.41667	.38462	.35714	.33333	.31250	.29412	.27778	.25000	.20000

TABLE 4.- Concluded

VALUES OF CONFIGURATION FACTOR P-8 - Concluded

D L	3.0	4.0	5.0	6.0	7.0	8.0	10.0	15.0	20.0	30.0	40.0
0.1	0.00988	0.00503	0.00305	0.00205	0.00147	0.00111	0.00069	0.00030	0.00017	0.00007	0.00004
.2	.01967	.01004	.00609	.00409	.00294	.00221	.00138	.00060	.00033	.00015	.00008
.3	.02929	.01501	.00912	.00613	.00440	.00332	.00208	.00090	.00050	.00022	.00012
.4	.03866	.01992	.01213	.00816	.00587	.00442	.00277	.00119	.00066	.00029	.00016
.5	.04772	.02475	.01511	.01018	.00732	.00552	.00346	.00149	.00083	.00036	.00020
.6	.05642	.02949	.01806	.01218	.00877	.00661	.00414	.00179	.00099	.00044	.00024
.7	.06469	.03412	.02097	.01417	.01021	.00770	.00483	.00209	.00116	.00051	.00028
.8	.07253	.03863	.02383	.01613	.01163	.00878	.00551	.00239	.00132	.00058	.00032
1.0	.08678	.04723	.02940	.01999	.01445	.01093	.00687	.00298	.00165	.00073	.00041
1.2	.09914	.05522	.03473	.02374	.01722	.01304	.00822	.00357	.00198	.00087	.00049
1.4	.10968	.06257	.03979	.02736	.01991	.01512	.00955	.00416	.00231	.00102	.00057
1.6	.11858	.06927	.04457	.03085	.02254	.01715	.01086	.00474	.00264	.00116	.00065
1.8	.12603	.07531	.04906	.03419	.02508	.01914	.01216	.00532	.00297	.00130	.00073
2.0	.13224	.08074	.05324	.03737	.02753	.02107	.01343	.00590	.00329	.00145	.00081
2.5	.14356	.09184	.06239	.04461	.03326	.02566	.01651	.00732	.00410	.00181	.00101
3.0	.15074	.10001	.06980	.05084	.03838	.02987	.01943	.00871	.00489	.00216	.00121
4.0	.15844	.11036	.08040	.06052	.04682	.03710	.02471	.01136	.00645	.00287	.00161
6.0	.16378	.11915	.09097	.07176	.05773	.04723	.03297	.01609	.00935	.00424	.00240
8.0	.16537	.12221	.09546	.07703	.06349	.05314	.03855	.01996	.01193	.00554	.00316
10.0	.16598	.12348	.09744	.07963	.06657	.05655	.04219	.02301	.01416	.00675	.00389
20.0	.16658	.12479	.09963	.08276	.07062	.06143	.04836	.03025	.02077	.01132	.00697
40.0	.16666	.12497	.09995	.08326	.07132	.06235	.04976	.03278	.02409	.01503	.01031
∞	.16667	.12500	.10000	.08333	.07143	.06250	.05000	.03333	.02500	.01667	.01250

TABLE 5
VALUES OF CONFIGURATION FACTOR P-9

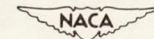
D \ L	1.1	1.2	1.3	1.4	1.5	1.6	1.7	1.8	2.0	2.5
0.1	0.01097	0.01428	0.01589	0.01669	0.01703	0.01710	0.01700	0.01679	0.01620	0.01446
.2	.01937	.02624	.02975	.03159	.03248	.03280	.03274	.03246	.03149	.02833
.3	.02572	.03618	.04176	.04483	.04645	.04717	.04730	.04705	.04589	.04163
.4	.03046	.04438	.05211	.05656	.05904	.06028	.06072	.06062	.05944	.05435
.5	.03398	.05112	.06101	.06690	.07035	.07223	.07307	.07320	.07216	.06652
.6	.03660	.05662	.06861	.07599	.08048	.08303	.08440	.08485	.08409	.07814
.7	.03856	.06112	.07511	.08397	.08954	.09292	.09479	.09562	.09526	.08924
.8	.04002	.06479	.08064	.09095	.09762	.10182	.10411	.10555	.10570	.09982
1.0	.04198	.07023	.08936	.10239	.11122	.11711	.12039	.12314	.12457	.11952
1.2	.04313	.07389	.09567	.11110	.12198	.12955	.13468	.13801	.14096	.13735
1.4	.04392	.07639	.10028	.11775	.13046	.13962	.14610	.15055	.15515	.15345
1.6	.04430	.07813	.10366	.12283	.13716	.14778	.15554	.16109	.16741	.16796
1.8	.04461	.07935	.10616	.12675	.14247	.15440	.16334	.16995	.17798	.18100
2.0	.04481	.08024	.10804	.12977	.14668	.15976	.16979	.17738	.18709	.19271
2.5	.04511	.08157	.11102	.13477	.15390	.16925	.18150	.19121	.20470	.21692
3.0	.04525	.08225	.11262	.13760	.15817	.17508	.18895	.20027	.21686	.23526
4.0	.04537	.08284	.11410	.14033	.16441	.18117	.19702	.21043	.23132	.25970
6.0	.04543	.08318	.11497	.14203	.16525	.18531	.20273	.21791	.24281	.28249
8.0	.04544	.08327	.11521	.14249	.16604	.18652	.20445	.22024	.24662	.29124
10.0	.04545	.08330	.11529	.14267	.16634	.18698	.20512	.22117	.24817	.29510
20.0	.04545	.08333	.11537	.14283	.16663	.18743	.20578	.22208	.24975	.29930
40.0	.04545	.08333	.11538	.14285	.16666	.18750	.20587	.22220	.24997	.29991
∞	.04545	.08333	.11538	.14286	.16667	.18750	.20588	.22222	.25000	.30000

TABLE 5.- Concluded

60

VALUES OF CONFIGURATION FACTOR P-9 - Concluded

D L	3.0	4.0	5.0	6.0	7.0	8.0	10.0	15.0	20.0	30.0	40.0
0.1	0.01285	0.01037	0.00864	0.00739	0.00645	0.00572	0.00466	0.00318	0.00242	0.00163	0.00123
.2	.02529	.02051	.01714	.01468	.01283	.01139	.00929	.00635	.00482	.00325	.00246
.3	.03733	.03042	.02548	.02187	.01913	.01699	.01387	.00950	.00722	.00488	.00368
.4	.04896	.04010	.03368	.02895	.02535	.02254	.01842	.01263	.00961	.00649	.00490
.5	.06020	.04955	.04173	.03593	.03150	.02803	.02294	.01575	.01198	.00810	.00612
.6	.07104	.05877	.04963	.04281	.03757	.03346	.02741	.01885	.01435	.00971	.00734
.7	.08151	.06777	.05739	.04958	.04357	.03883	.03185	.02193	.01671	.01132	.00855
.8	.09160	.07656	.06500	.05625	.04949	.04414	.03625	.02500	.01906	.01292	.00977
1.0	.11069	.09346	.07980	.06930	.06111	.05460	.04494	.03109	.02374	.01660	.01218
1.2	.12837	.10951	.09403	.08194	.07244	.06483	.05349	.03710	.02837	.01928	.01459
1.4	.14473	.12474	.10771	.09419	.08347	.07483	.06188	.04306	.03297	.02243	.01699
1.6	.15981	.13916	.12084	.10605	.09420	.08461	.07013	.04894	.03753	.02557	.01938
1.8	.17372	.15280	.13344	.11753	.10465	.09416	.07824	.05476	.04205	.02869	.02176
2.0	.18650	.16570	.14552	.12863	.11482	.10349	.08620	.06052	.04654	.03179	.02413
2.5	.21407	.19485	.17353	.15477	.13901	.12586	.10547	.07462	.05759	.03948	.03002
3.0	.23624	.21996	.19859	.17871	.16151	.14689	.12386	.08831	.06841	.04707	.03585
4.0	.26819	.25991	.24077	.22046	.20172	.18514	.15806	.11450	.08937	.06193	.04733
6.0	.30196	.31008	.29979	.28320	.26521	.24775	.21682	.16221	.12857	.09042	.06960
8.0	.31666	.33663	.33554	.32500	.31050	.29475	.26409	.20402	.16428	.11730	.09095
10.0	.32367	.35113	.35730	.35264	.34244	.32958	.30166	.24038	.19665	.14260	.11139
20.0	.33187	.37087	.39152	.40214	.40644	.40646	.39840	.35856	.31543	.24698	.20047
40.0	.33314	.37443	.39877	.41442	.42492	.43202	.43956	.43680	.41888	.36970	.32231
∞	.33333	.37500	.40000	.41667	.42857	.43750	.45000	.46667	.47500	.48333	.48750



NACA TN 2836

TABLE 6
VALUES OF CONFIGURATION FACTOR P-10

θ (deg) L	10	20	30	40	50	60	65	70	75	80	90
0	0.00380	0.01508	0.03349	0.05849	0.08930	0.12500	0.14435	0.16450	0.18530	0.20659	0.25000
.02	.00370	.01470	.03270	.05717	.08744	.12261	.14173	.16168	.18233	.20350	.24682
.05	.00356	.01415	.03151	.05520	.08464	.11904	.13782	.15747	.17788	.19888	.24205
.1	.00332	.01323	.02954	.05195	.08001	.11311	.13132	.15049	.17050	.19121	.23414
.2	.00286	.01144	.02572	.04561	.07097	.10151	.11860	.13680	.15601	.17613	.21858
.4	.00206	.00829	.01890	.03418	.05449	.08015	.09505	.11134	.12899	.14795	.18944
.6	.00144	.00585	.01353	.02501	.04095	.06218	.07504	.08950	.10563	.12345	.16399
1.0	.00070	.00289	.00687	.01319	.02275	.03690	.04624	.05743	.07073	.08634	.12500
2.0	.00016	.00066	.00162	.00329	.00616	.01129	.01534	.02094	.02876	.03962	.07379
4.0	.00002	.00010	.00025	.00053	.00104	.00209	.00306	.00463	.00735	.01236	.03399
6.0	.00001	.00003	.00008	.00017	.00033	.00068	.00102	.00160	.00272	.00515	.02628
10.0	0	.00001	.00002	.00004	.00007	.00015	.00023	.00038	.00068	.00142	.01586
20.0	0	0	0	0	.00001	.00002	.00003	.00005	.00009	.00020	.00795

TABLE 7
VALUES OF CONFIGURATION FACTOR P-11

θ (deg) L	10	20	30	40	50	60	65	70	75	80	90
0	0.25000	0.25000	0.25000	0.25000	0.25000	0.25000	0.25000	0.25000	0.25000	0.25000	0.25000
.02	.21869	.23311	.23817	.24086	.24262	.24393	.24449	.24500	.24548	.24594	.24682
.05	.17452	.20821	.22056	.22722	.23160	.23485	.23623	.23751	.23871	.23985	.24205
.1	.11511	.16932	.19214	.20492	.21345	.21985	.22258	.22511	.22749	.22976	.23414
.2	.05015	.10714	.14146	.16333	.17883	.19086	.19608	.20095	.20555	.20998	.21858
.4	.01345	.04252	.07254	.09860	.12067	.13982	.14863	.15709	.16531	.17338	.18944
.6	.00522	.01908	.03788	.05859	.07963	.10047	.11083	.12120	.13162	.14218	.16399
1.0	.00139	.00556	.01260	.02261	.03575	.05225	.06184	.07238	.08391	.09649	.12500
2.0	.00020	.00082	.00201	.00403	.00744	.01330	.01775	.02371	.03171	.04233	.07379
4.0	.00003	.00011	.00027	.00056	.00110	.00221	.00322	.00486	.00767	.01276	.03899
6.0	.00001	.00003	.00008	.00017	.00034	.00070	.00104	.00164	.00278	.00524	.02628
10.0	0	.00001	.00002	.00004	.00007	.00016	.00024	.00038	.00068	.00143	.01586
20.0	0	0	0	0	.00001	.00002	.00003	.00005	.00009	.00020	.00795


 NACA

TABLE 8
VALUES OF CONFIGURATION FACTOR L-1

$y \backslash x$	0.1	0.2	0.4	0.6	1.0	2.0	10.0	∞
0.1	0.0031	0.0061	0.0115	0.0155	0.0203	0.0239	0.0249	0.0249
.15	.0047	.0092	.0172	.0233	.0305	.0358	.0373	.0373
.2	.0062	.0122	.0228	.0309	.0405	.0475	.0495	.0495
.3	.0092	.0181	.0337	.0456	.0599	.0704	.0734	.0734
.4	.0120	.0236	.0440	.0597	.0784	.0923	.0962	.0963
.6	.0171	.0336	.0626	.0851	.1122	.1325	.1384	.1385
.8	.0213	.0419	.0784	.1067	.1412	.1675	.1753	.1754
1.0	.0248	.0488	.0914	.1247	.1656	.1974	.2070	.2071
2.0	.0350	.0690	.1297	.1781	.2397	.2912	.3088	.3090
∞	.0498	.0981	.1857	.2572	.3536	.4472	.4975	.5000

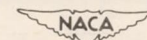


TABLE 9
VALUES OF CONFIGURATION FACTOR L-2

N L	0.05	0.1	0.2	0.4	0.6	1.0	2.0	4.0	6.0	10.0	20.0	∞
$\phi = 30^\circ$												
0	0.93301	0.93301	0.93301	0.93301	0.93301	0.93301	0.93301	0.93301	0.93301	0.93301	0.93301	0.93301
.02	.83366	.89071	.90812	.91453	.91621	.91727	.91780	.91795	.91798	.91799	.91800	.91800
.05	.36419	.77932	.86670	.88919	.89426	.89727	.89870	.89909	.89915	.89919	.89917	.89921
.1	.04059	.35780	.76333	.84533	.85939	.86685	.87012	.87093	.87108	.87115	.87118	.87119
.2	.00557	.03869	.34509	.73163	.78725	.80658	.81910	.82097	.82129	.82144	.82151	.82153
.4	.00095	.00494	.03504	.32021	.58627	.70061	.73048	.73542	.73614	.73648	.73662	.73666
.6	.00034	.00161	.00942	.08292	.29645	.57456	.65267	.66261	.66389	.66445	.66467	.66473
1.0			.00195	.01281	.04795	.25367	.51379	.54422	.54717	.54832	.54871	.54882
2.0				.00119	.00347	.01673	.17658	.34719	.36074	.36463	.36569	.36595
4.0						.00114	.00927	.10285	.18082	.20355	.20747	.20812
6.0							.00172	.01806	.07111	.13062	.14171	.14300
10.0								.00181	.00741	.04353	.08338	.08723
20.0										.00193	.02196	.04394
$\phi = 60^\circ$												
0	0.75000	0.75000	0.75000	0.75000	0.75000	0.75000	0.75000	0.75000	0.75000	0.75000	0.75000	0.75000
.02	.54883	.65115	.69263	.71082	.71559	.71864	.72023	.72074	.72074	.72078	.72080	.72081
.05	.24279	.48264	.61065	.66105	.67433	.68254	.68662	.68773	.68793	.68804	.68809	.68810
.1	.06321	.23560	.46539	.58315	.61322	.63142	.64015	.64244	.64287	.64309	.64318	.64320
.2	.01293	.05950	.22144	.43170	.50214	.54502	.56473	.56966	.57055	.57097	.57118	.57124
.4	.00253	.01133	.05245	.19463	.30785	.40311	.45029	.46151	.46342	.46451	.46474	.46486
.6	.00094	.00407	.01877	.08429	.17072	.28771	.36391	.38264	.38569	.38735	.38780	.38798
1.0	.00025	.00105	.00468	.02198	.05323	.13283	.23973	.27547	.28133	.28402	.28507	.28539
2.0				.00280	.00694	.02190	.08028	.14089	.15497	.16150	.16387	.16455
4.0						.00245	.01172	.04288	.06446	.07911	.08481	.08634
6.0							.00318	.01455	.02897	.04635	.05560	.05813
10.0								.01751	.03009	.03506	.03506	
20.0										.00224	.00878	.01757
$\phi = 90^\circ$												
0	0.50000	0.50000	0.50000	0.50000	0.50000	0.50000	0.50000	0.50000	0.50000	0.50000	0.50000	0.50000
.02	.30800	.39158	.43557	.45611	.46203	.46594	.46796	.46852	.46863	.46869	.46872	.46873
.05	.14094	.26361	.35229	.40517	.41974	.42943	.43449	.43591	.43618	.43632	.43638	.43640
.1	.04925	.13547	.25099	.33445	.36205	.38098	.39100	.39384	.39423	.39466	.39478	.39482
.2	.01302	.04579	.12430	.22675	.27199	.30649	.32588	.33142	.33258	.33314	.33338	.33346
.4	.00292	.01126	.03935	.10530	.15401	.20388	.23802	.24887	.25101	.25213	.25261	.25277
.6	.00113	.00445	.01664	.05293	.08903	.13761	.17992	.19528	.19844	.20011	.20082	.20106
1.0	.00031	.00124	.00482	.01746	.03393	.06562	.10884	.13041	.13540	.13811	.13929	.13968
2.0				.00284	.00611	.01486	.03756	.06077	.06863	.07350	.07577	.07655
4.0						.00229	.00781	.01959	.02718	.03390	.03785	.03938
6.0							.00263	.00810	.01317	.01939	.02422	.02640
10.0								.00219	.00420	.00794	.01271	.01589
20.0										.00159	.00398	.00795
$\phi = 120^\circ$												
0	0.25000	0.25000	0.25000	0.25000	0.25000	0.25000	0.25000	0.25000	0.25000	0.25000	0.25000	0.25000
.02	.13639	.17986	.20670	.22041	.22572	.22735	.22833	.22923	.22932	.22937	.22939	.22940
.05	.06404	.11537	.16057	.18859	.19788	.20436	.20791	.20892	.20912	.20922	.20927	.20928
.1	.02547	.06113	.10877	.14874	.16395	.17539	.18195	.18413	.18431	.18452	.18460	.18463
.2	.00773	.02345	.05554	.09641	.11671	.13416	.14537	.14901	.14976	.15016	.15034	.15040
.4	.00193	.00665	.01984	.04552	.06374	.08395	.10015	.10630	.10771	.10848	.10899	.10892
.6	.00077	.00280	.00973	.02430	.03759	.05335	.07237	.08071	.08259	.08366	.08415	.08432
1.0			.00289	.00896	.01559	.02696	.04246	.05174	.05434	.05594	.05668	.05696
2.0				.00170	.00333	.00705	.01504	.02320	.02642	.02876	.03005	.03057
4.0						.00129	.00369	.00774	.01035	.01289	.01471	.01561
6.0							.00138	.00349	.00522	.00735	.00928	.01045
10.0								.00114	.00174	.00314	.00480	.00629
20.0										.00157	.00315	.00315
$\phi = 150^\circ$												
0	0.06699	0.06699	0.06699	0.06699	0.06699	0.06699	0.06699	0.06699	0.06699	0.06699	0.06699	0.06699
.02	.03404	.04429	.05348	.05771	.05902	.05992	.06040	.06053	.06057	.06058	.06059	.06059
.05	.01622	.02864	.04031	.04825	.05099	.05290	.05411	.05444	.05451	.05454	.05456	.05456
.1	.00684	.01542	.02636	.03707	.04125	.04454	.04654	.04716	.04728	.04735	.04738	.04739
.2	.00264	.00626	.01387	.02356	.02853	.03309	.03624	.03734	.03758	.03771	.03776	.03778
.4	.00061	.00191	.00522	.01119	.01536	.02008	.02415	.02590	.02631	.02662	.02666	.02669
.6			.00251	.00613	.00914	.01312	.01726	.01926	.01985	.02017	.02033	.02038
1.0				.00238	.00401	.00635	.00990	.01219	.01282	.01327	.01351	.01359
2.0						.00179	.00356	.00536	.00612	.00671	.00723	.00723
4.0								.00183	.00239	.00297	.00343	.00368
6.0									.00123	.00169	.00207	.00246
10.0											.00148	.00148
20.0												.00074

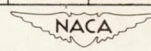


TABLE 10
VALUES OF CONFIGURATION FACTOR L-3 OR A-7

D L	1.1	1.2	1.3	1.4	1.5	1.6	1.7	1.8	2.0	2.5	3.0	4.0	5.0	6.0	7.0	8.0	10.0	15.0	20.0	30.0	40.0
0.2	0.579	0.365	0.250	0.183	0.141	0.113	0.092	0.077	0.057	0.031	0.020	0.010	0.006	0.004	0.003	0.002	0.001	0.001	0	0	0
.4	.726	.538	.409	.318	.256	.209	.174	.148	.110	.061	.039	.020	.012	.008	.006	.004	.003	.001	.001	0	0
.6	.783	.623	.501	.408	.339	.284	.241	.207	.157	.090	.058	.030	.018	.012	.009	.007	.004	.002	.001	0	0
.8	.814	.671	.558	.469	.398	.341	.294	.256	.198	.116	.076	.039	.024	.016	.012	.009	.006	.002	.001	.001	0
1.0	.833	.702	.596	.510	.441	.383	.335	.295	.232	.140	.092	.049	.030	.020	.015	.011	.007	.003	.002	.001	0
1.2	.845	.723	.623	.541	.473	.415	.367	.326	.261	.161	.108	.058	.036	.024	.017	.013	.008	.004	.002	.001	0
1.4	.854	.738	.643	.563	.497	.441	.393	.351	.285	.180	.123	.066	.041	.028	.020	.015	.010	.004	.002	.001	.001
1.6	.861	.750	.658	.581	.516	.461	.413	.372	.305	.197	.136	.075	.047	.032	.023	.017	.011	.005	.003	.001	.001
1.8	.866	.759	.670	.595	.532	.477	.430	.390	.322	.212	.148	.082	.052	.035	.026	.020	.012	.005	.003	.001	.001
2.0	.871	.766	.680	.606	.544	.491	.444	.404	.337	.225	.159	.090	.057	.039	.028	.022	.014	.006	.003	.001	.001
3.0	.883	.788	.709	.641	.584	.534	.490	.451	.386	.272	.201	.121	.079	.056	.041	.031	.020	.009	.005	.002	.001
4.0	.890	.800	.724	.659	.604	.556	.513	.476	.413	.301	.228	.143	.097	.070	.052	.040	.026	.012	.007	.003	.002
6.0	.896	.811	.739	.678	.625	.578	.538	.502	.440	.331	.260	.172	.122	.091	.070	.055	.037	.017	.010	.004	.002
8.0	.899	.816	.747	.687	.635	.590	.550	.515	.455	.348	.277	.190	.139	.106	.083	.067	.046	.022	.013	.006	.003
10.0	.901	.820	.751	.692	.641	.597	.558	.523	.464	.358	.288	.201	.150	.116	.092	.075	.053	.026	.015	.007	.004
∞	.909	.833	.769	.714	.667	.625	.588	.556	.500	.400	.333	.250	.200	.167	.143	.125	.100	.067	.050	.033	.025

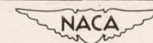


TABLE 11
VALUES OF CONFIGURATION FACTOR L-4 OR A-8

D L	1.1	1.2	1.3	1.4	1.5	1.6	1.7	1.8	2.0	2.5	3.0	4.0	5.0	6.0	7.0	8.0	10.0	15.0	20.0	30.0	40.0
0.2	0.021	0.028	0.031	0.033	0.034	0.034	0.034	0.033	0.032	0.029	0.026	0.021	0.017	0.015	0.013	0.011	0.009	0.006	0.005	0.003	0.002
.4	.036	.050	.057	.061	.063	.064	.064	.063	.062	.056	.050	.041	.034	.029	.026	.023	.019	.013	.010	.007	.005
.6	.047	.067	.079	.085	.089	.091	.091	.091	.089	.082	.073	.061	.051	.043	.038	.034	.028	.019	.014	.010	.007
.8	.054	.081	.096	.106	.111	.114	.116	.116	.114	.106	.096	.079	.067	.057	.050	.045	.037	.025	.019	.013	.010
1.0	.060	.091	.111	.123	.131	.135	.138	.139	.138	.129	.117	.097	.082	.071	.062	.056	.046	.031	.024	.016	.012
1.2	.064	.101	.124	.138	.148	.154	.157	.159	.159	.150	.138	.115	.098	.084	.074	.066	.054	.037	.029	.020	.015
1.4	.067	.108	.134	.151	.163	.170	.175	.178	.179	.170	.157	.132	.112	.098	.086	.077	.063	.044	.033	.023	.017
1.6	.070	.114	.143	.163	.176	.185	.191	.194	.197	.189	.175	.148	.127	.110	.097	.087	.072	.050	.038	.026	.019
1.8	.072	.118	.150	.172	.188	.198	.205	.210	.213	.207	.193	.164	.141	.123	.109	.097	.080	.056	.043	.029	.022
2.0	.074	.123	.157	.181	.198	.210	.218	.223	.228	.224	.210	.180	.155	.135	.120	.107	.089	.062	.047	.032	.024
3.0	.079	.136	.178	.210	.234	.252	.266	.276	.288	.293	.282	.249	.219	.193	.172	.155	.129	.091	.070	.048	.036
4.0	.082	.143	.190	.227	.256	.279	.296	.310	.329	.344	.338	.307	.274	.245	.220	.200	.168	.119	.092	.063	.048
6.0	.085	.151	.203	.245	.281	.308	.331	.349	.377	.411	.417	.397	.365	.333	.304	.278	.237	.172	.134	.093	.071
8.0	.086	.155	.210	.255	.293	.324	.350	.372	.406	.452	.468	.460	.433	.402	.372	.345	.299	.221	.174	.122	.093
10.0	.087	.157	.214	.261	.302	.334	.362	.386	.423	.479	.502	.506	.485	.458	.429	.401	.352	.266	.211	.149	.115
∞	.091	.167	.231	.296	.333	.375	.412	.444	.500	.600	.667	.750	.800	.833	.857	.874	.900	.933	.950	.967	.975



TABLE 13
VALUES OF CONFIGURATION FACTOR A-2

[These values may be in error by 0.0004]

N \ L	0.05	0.1	0.2	0.4	0.6	1.0	2.0	4.0	6.0	10.0	20.0	∞
$\phi = 30^\circ$												
0.1	0.4205	0.7314	0.8604		0.8948	0.8981	0.8996	0.9000	0.9001	0.9001	0.9001	0.9001
.2	.2132	.4098	.7188		.8595	.8676	.8719	.8728	.8729	.8730	.8730	.8730
.4	.1451	.2133	.4055		.7772	.8099	.8228	.8249	.8252	.8254	.8255	.8255
.6	.0976	.1497	.2749		.6669	.7534	.7789	.7827	.7832	.7835	.7836	.7836
1.0	.0586	.0900	.1772		.4465	.6202	.7002	.7100	.7111	.7116	.7118	.7118
2.0	.0293	.0451	.0889		.2354	.3244	.5235	.5736	.5778	.5793	.5797	.5798
4.0	.0147	.0225	.0445		.1181	.1803	.2759	.3961	.4196	.4261	.4274	.4277
6.0	.0098	.0150	.0297		.0788	.1203	.1868	.2807	.3216	.3393	.3426	.3431
10.0	.0059	.0090	.0178		.0473	.0722	.1123	.1709	.2030	.2389	.2505	.2518
20.0	.0029	.0045	.0089		.0236	.0361	.0562	.0856	.1019	.1203	.1261	-----
$\phi = 60^\circ$												
0.1	0.3024	0.4866	0.6093		0.6766	0.6851	0.6893	0.6904	0.6906	0.6907	0.6907	0.6908
.2	.1732	.2970	.4720		.6169	.6362	.6453	.6477	.6481	.6483	.6484	.6484
.4	.1055	.1684	.2868		.5095	.5541	.5751	.5803	.5812	.5816	.5818	.5819
.6	.0717	.1172	.2025		.4177	.4839	.5185	.5270	.5284	.5292	.5294	.5295
1.0	.0435	.0725	.1292		.2891	.3712	.4300	.4462	.4488	.4502	.4506	.4507
2.0	.0218	.0364	.0653		.1612	.2128	.2899	.3234	.3297	.3325	.3335	.3340
4.0	.0109	.0182	.0328		.0816	.1204	.1630	.2064	.2192	.2260	.2286	.2293
6.0	.0073	.0122	.0219		.0546	.0807	.1122	.1469	.1618	.1719	.1761	.1772
10.0	.0044	.0073	.0131		.0328	.0495	.0678	.0922	.1040	.1160	.1231	.1253
20.0	.0022	.0036	.0066		.0164	.0243	.0340	.0465	.0528	.0595	.0631	-----
$\phi = 90^\circ$												
0.02	0.39908	0.44375	0.46615	0.47725	0.47943	0.48138	0.48239	0.48267	0.48273	0.48275	0.48276	0.48277
.05	.28738	.37202	.42337	.44852	.45587	.46073	.46327	.46397	.46411	.46418	.46421	.46422
.1	.18601	.28189	.36216	.40859	.42290	.43251	.43756	.43898	.43925	.43939	.43943	.43947
.2	.10584	.18108	.27104	.34295	.36884	.38719	.39711	.39994	.40048	.40076	.40089	.40092
.4	.05606	.10215	.17147	.25032	.28809	.31924	.33784	.34339	.34447	.34503	.34528	.34535
.6	.03799	.07048	.12295	.19206	.23147	.26396	.29429	.30238	.30399	.30482	.30518	.30530
1.0	.02304	.04325	.07744	.12770	.16138	.20004	.23285	.24522	.24783	.24921	.24980	.25000
2.0	.01158	.02188	.03971	.06757	.08829	.11643	.14930	.16731	.17193	.17455	.17571	.17611
4.0	.00580	.01097	.02000	.03434	.04536	.06131	.08365	.10136	.10776	.11210	.11427	.11505
6.0	.00388	.00732	.01335	.02296	.03040	.04130	.05731	.07184	.07822	.08331	.08624	.08738
10.0	.00232	.00439	.00802	.01380	.01829	.02492	.03491	.04484	.04998	.05502	.05876	.06053
20.0	.00116	.00220	.00401	.00691	.00916	.01249	.01757	.02285	.02587	.02938	.03302	.03578
$\phi = 120^\circ$												
0.1	0.0871	0.1284	0.1667		0.2008	0.2070	0.2104	0.2115	0.2116	0.2117	0.2118	0.2118
.2	.0538	.0843	.1227		.1700	.1804	.1866	.1886	.1889	.1891	.1892	.1892
.4	.0314	.0507	.0790		.1287	.1437	.1538	.1573	.1580	.1584	.1586	.1586
.6	.0216	.0357	.0576		.1023	.1186	.1311	.1358	.1368	.1374	.1377	.1377
1.0	.0131	.0218	.0374		.0715	.0870	.1012	.1074	.1090	.1099	.1103	.1104
2.0	.0066	.0111	.0193		.0412	.0518	.0643	.0720	.0742	.0757	.0765	.0767
4.0	.0033	.0056	.0097		.0213	.0297	.0377	.0443	.0469	.0489	.0501	.0506
6.0	.0022	.0037	.0065		.0143	.0200	.0262	.0316	.0340	.0361	.0375	.0382
10.0	.0013	.0022	.0039		.0086	.0121	.0160	.0200	.0219	.0238	.0254	.0264
20.0	.0007	.0011	.0020		.0043	.0061	.0081	.0102	.0113	.0125	.0133	-----
$\phi = 150^\circ$												
0.1	0.0225	0.0325	0.0424		0.0520	0.0538	0.0549	0.0553	0.0553	0.0554	0.0554	0.0554
.2	.0141	.0214	.0310		.0432	.0462	.0480	.0486	.0487	.0488	.0488	.0489
.4	.0084	.0130	.0201		.0322	.0361	.0389	.0399	.0401	.0403	.0403	.0403
.6	.0057	.0089	.0147		.0255	.0295	.0327	.0341	.0344	.0346	.0346	.0347
1.0	.0035	.0055	.0093		.0178	.0215	.0249	.0266	.0270	.0273	.0274	.0275
2.0	.0017	.0028	.0048		.0098	.0127	.0157	.0177	.0182	.0186	.0187	.0189
4.0	.0009	.0014	.0024		.0051	.0068	.0086	.0108	.0114	.0119	.0120	.0124
6.0	.0006	.0009	.0016		.0034	.0046	.0059	.0075	.0082	.0088	.0090	.0091
10.0	.0003	.0006	.0010		.0021	.0028	.0036	.0047	.0052	.0055	.0055	.0055
20.0	.0002	.0003	.0005		.0010	.0014	.0018	.0024	.0027	.0029	.0029	.0029

TABLE 12

VALUES OF CONFIGURATION FACTOR A-1

$y \backslash x$	0.1	0.2	0.4	0.6	1.0	2.0	4.0	6.0	10.0	20.0	∞
0.1	0.00316	0.00626	0.01207	0.01715	0.02492	0.03514	0.04210	0.04463	0.04671	0.04829	0.04988
.2	.00626	.01240	.02391	.03398	.04941	.06971	.08353	.08859	.09272	.09586	.09902
.4	.01207	.02392	.04614	.06560	.09554	.13513	.16219	.17209	.18021	.18638	.19258
.6	.01715	.03398	.06560	.09336	.13627	.19341	.23271	.24712	.25896	.26795	.27698
1.0	.02492	.04941	.09554	.13627	.19982	.28588	.34596	.36813	.38638	.40026	.41421
2.0	.03514	.06971	.13513	.19342	.28588	.41525	.50899	.54421	.57338	.59563	.61803
4.0	.04209	.08353	.16219	.23271	.34596	.50899	.63204	.67954	.71933	.74990	.78078
10.0	.04671	.09270	.18021	.25896	.38638	.57361	.71933	.77741	.82699	.86563	.90499
∞	.04988	.09902	.19258	.27698	.41421	.61803	.78078	.84713	.90499	.95125	1.00000

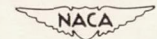
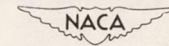


TABLE 14

VALUES OF CONFIGURATION FACTOR A-5

E D	0.1	0.2	0.3	0.4	0.5	0.6	0.8	1.0	2.0	3.0	4.0	5.0	6.0	8.0	10.0
0.1	0.00010	0.00040	0.00089	0.00158	0.00248	0.00356	0.00634	0.00990	0.03959	0.08902	0.15812	0.24672	0.35451	0.62344	0.90488
.15	-----	-----	-----	-----	-----	-----	-----	-----	.08784	.19698	.34799	.53648	.74445	.95561	.98256
.2	.00038	.00154	.00346	.00616	.00961	.01384	.02459	.03840	.15278	.33944	.58388	.81900	.92759	.97538	.98690
.3	-----	-----	-----	-----	-----	-----	-----	-----	.31803	.64586	.86472	.93590	.96200	.98152	.98839
.4	.00158	.00552	.01240	.02200	.03432	.04930	.08713	.13502	.48769	.80000	.91153	.95016	.96769	.98300	.98946
.6	-----	-----	.02367	.04187	.06498	.09276	.16121	.24388	.67889	.86822	.93062	.95716	.97085	.98394	.98982
.8	-----	-----	-----	-----	-----	-----	-----	-----	.73986	.88398	.93564	.95918	.97182	.98424	.98994
1.0	.00499	.01980	.04399	.07686	.11722	.16393	.27005	.38196	.76393	.89023	.93774	.96006	.97224	.98438	.99000
2.0	-----	-----	.06803	.11586	.17158	.23196	.35532	.46887	.79176	.89770	.94035	.96118	.97280	.98456	.99008
5.0	.00952	.03709	.07987	.13393	.19498	.25906	.38447	.49500	.79872	.89964	.94104	.96148	.97294	.98460	.99010
10.0	.00980	.03811	.08188	.13692	.19872	.26328	.38880	.49875	.79968	.89991	.94114	.96152	.97297	-----	-----
20.0	.00988	.03838	.08240	.13768	.19968	.26435	.38988	.49969	.79992	.89998	.94117	.96154	-----	-----	-----
∞	.00990	.03846	.08256	.13792	.19999	.26470	.39023	.49999	.80000	.90000	.94120	.96155	-----	-----	-----



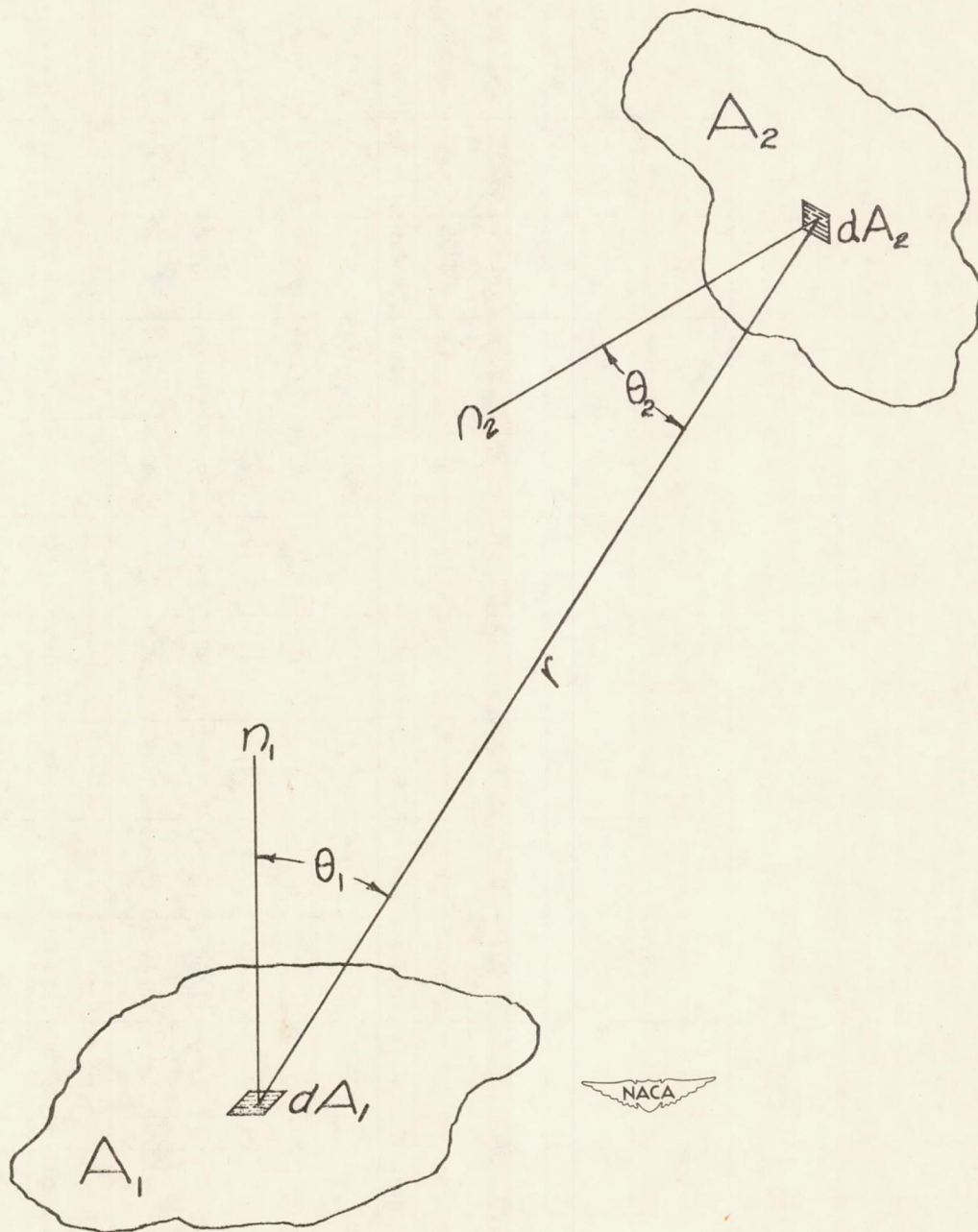


Figure 1.- Geometry for radiant interchange between two plane point sources.

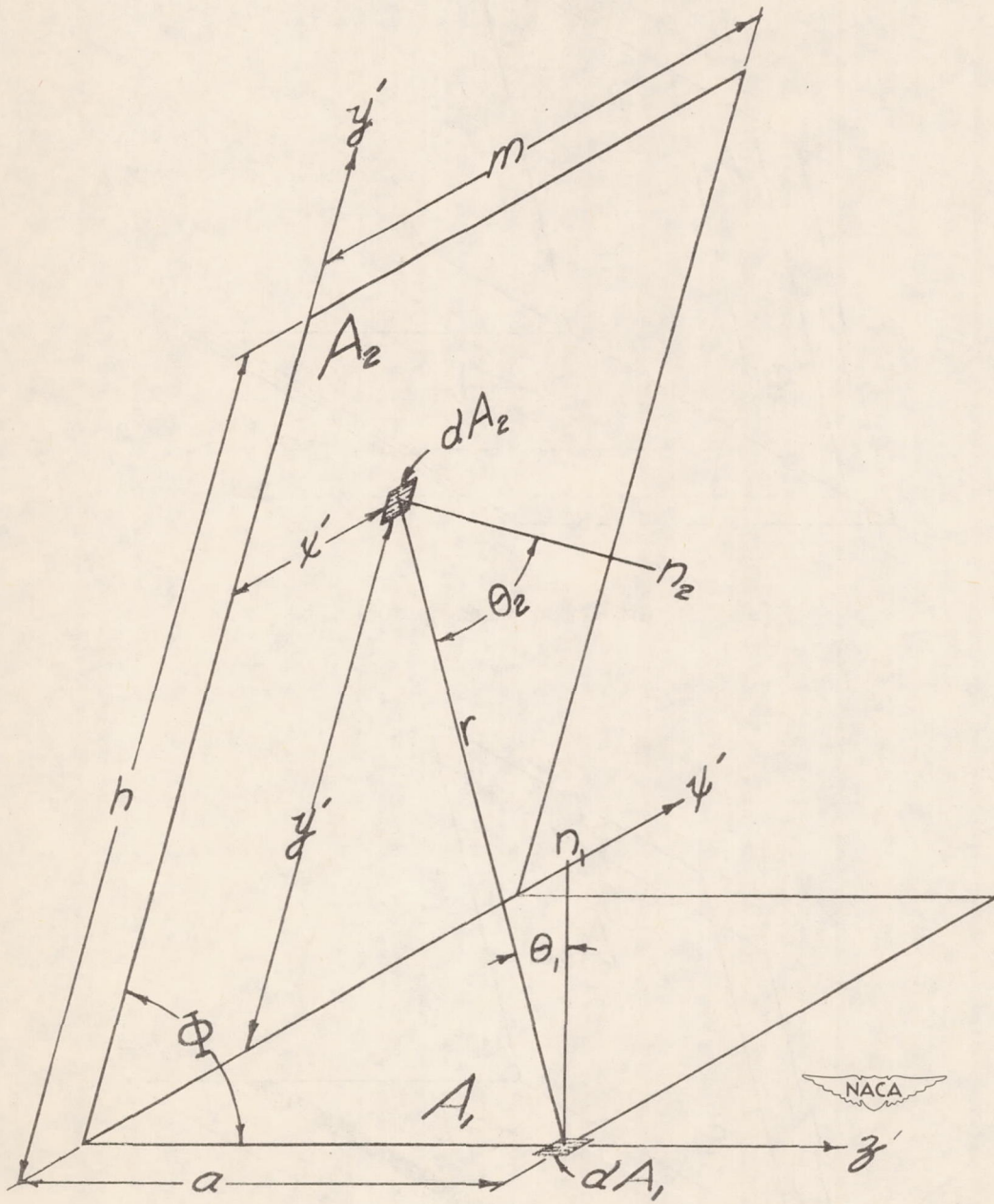


Figure 2.- Geometry of configuration P-2.

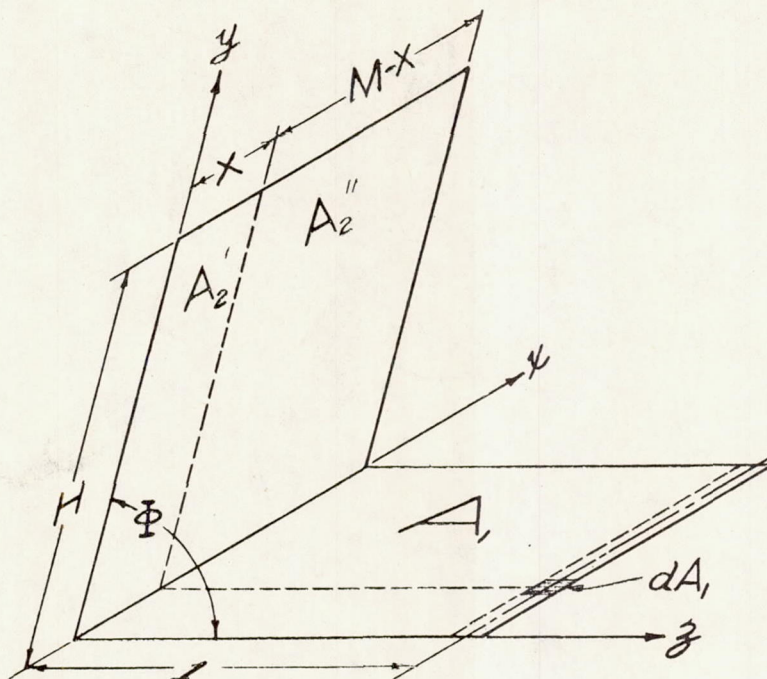
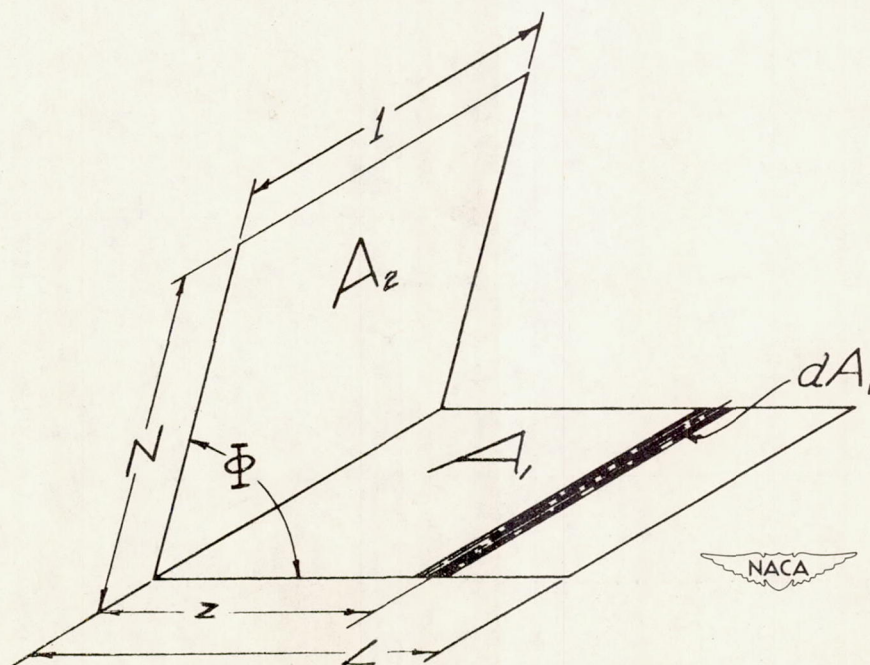
(a) Integration with respect to x .(b) Integration with respect to z .

Figure 3.- Geometry of configuration L-2.

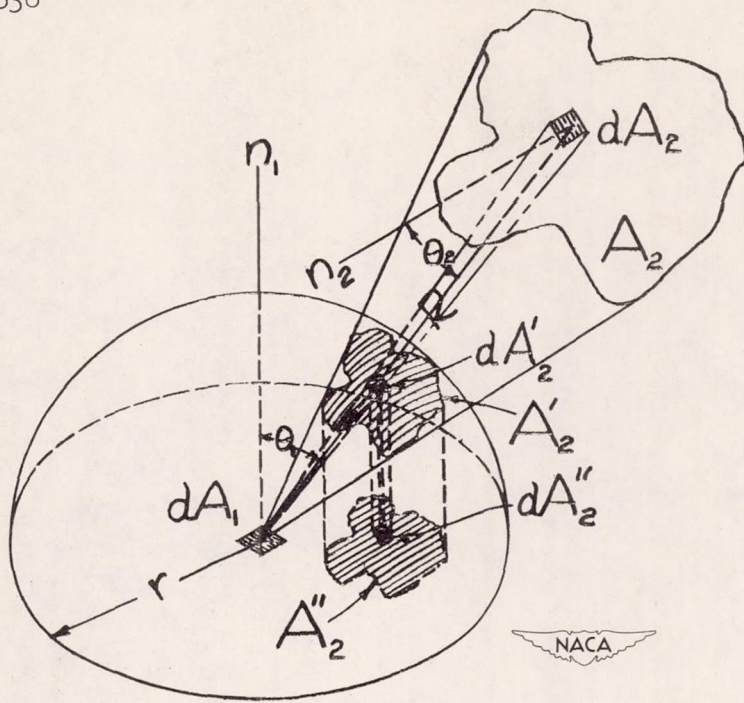


Figure 4.- Illustration of Nusselt's geometric interpretation of configuration-factor equation.

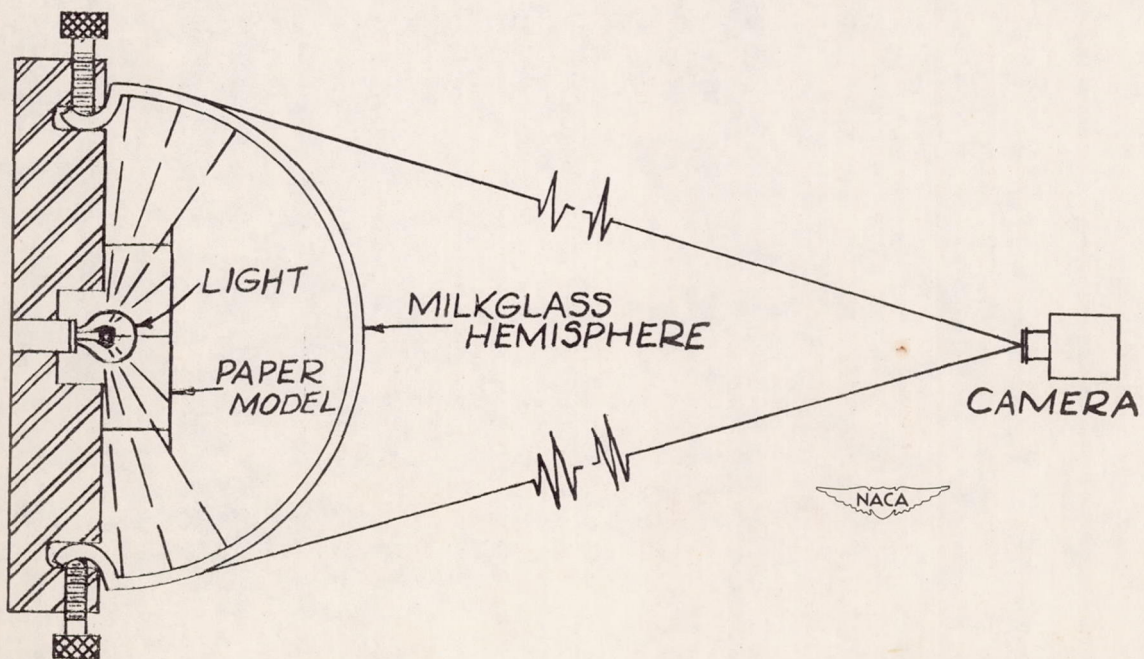


Figure 5.- Eckert's optical projector.

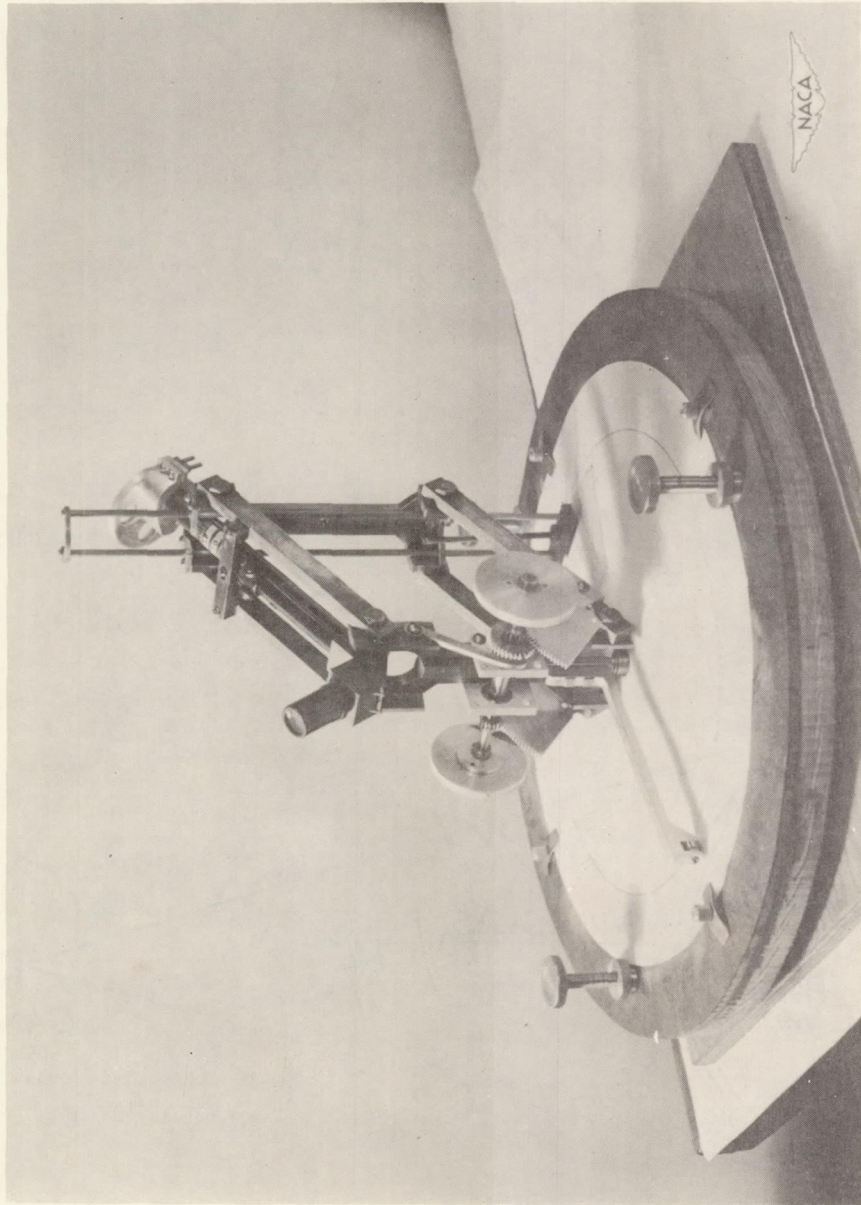


Figure 6.- Purdue University mechanical integrator.

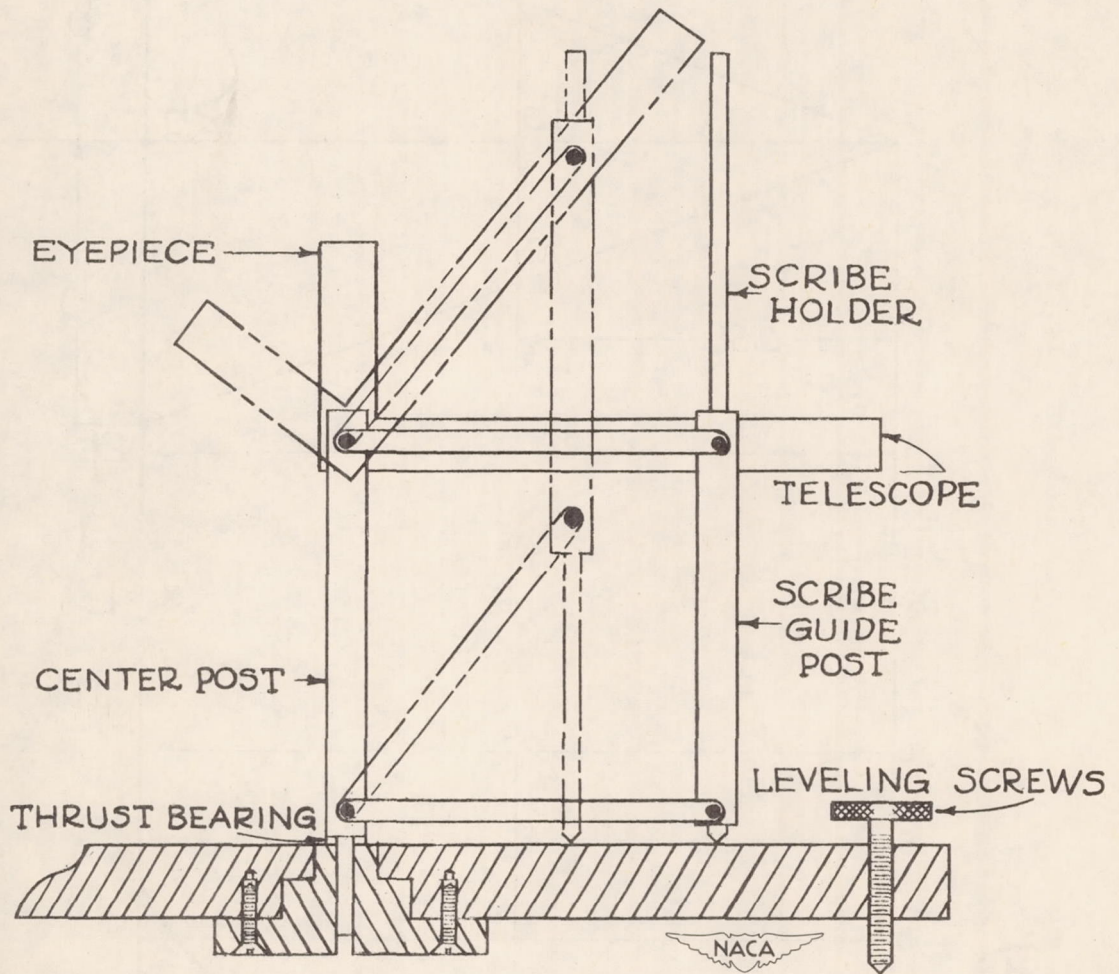


Figure 7.- Schematic diagram of Purdue University mechanical integrator.

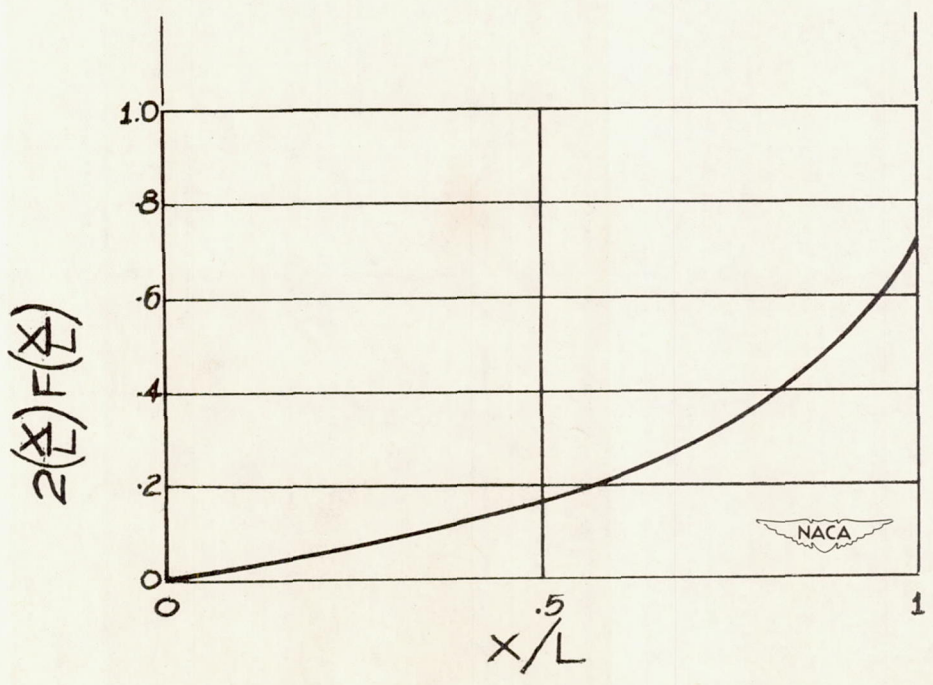
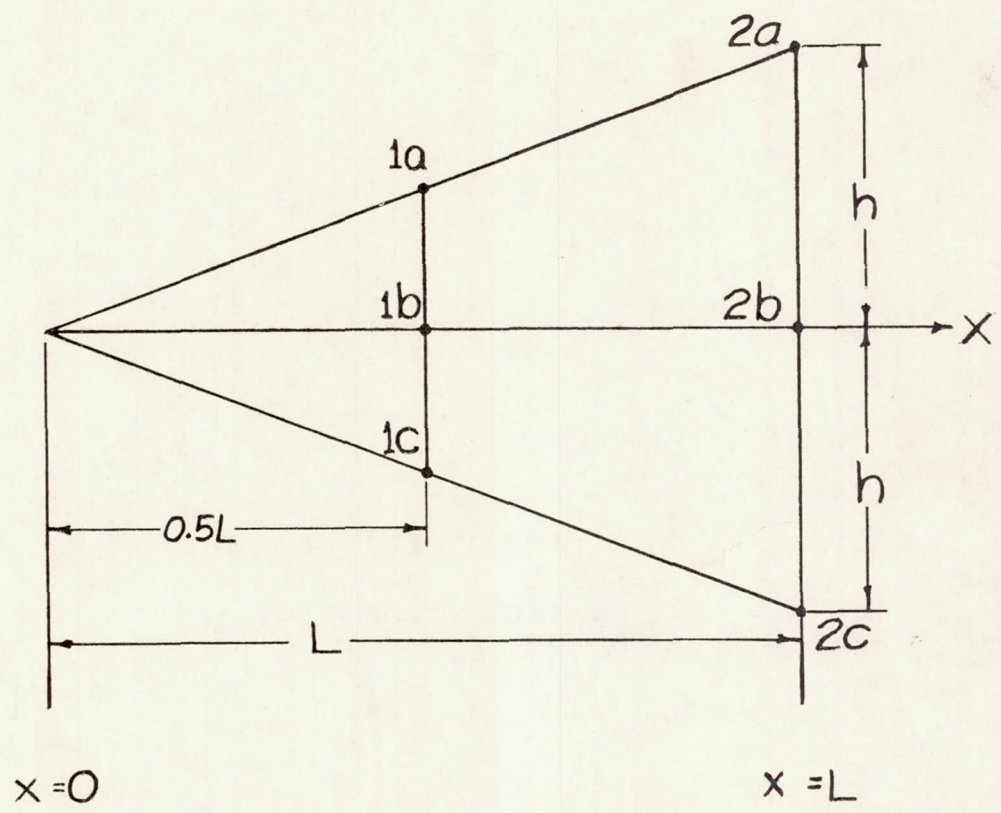


Figure 8.- Graphical determination of mean configuration factor.

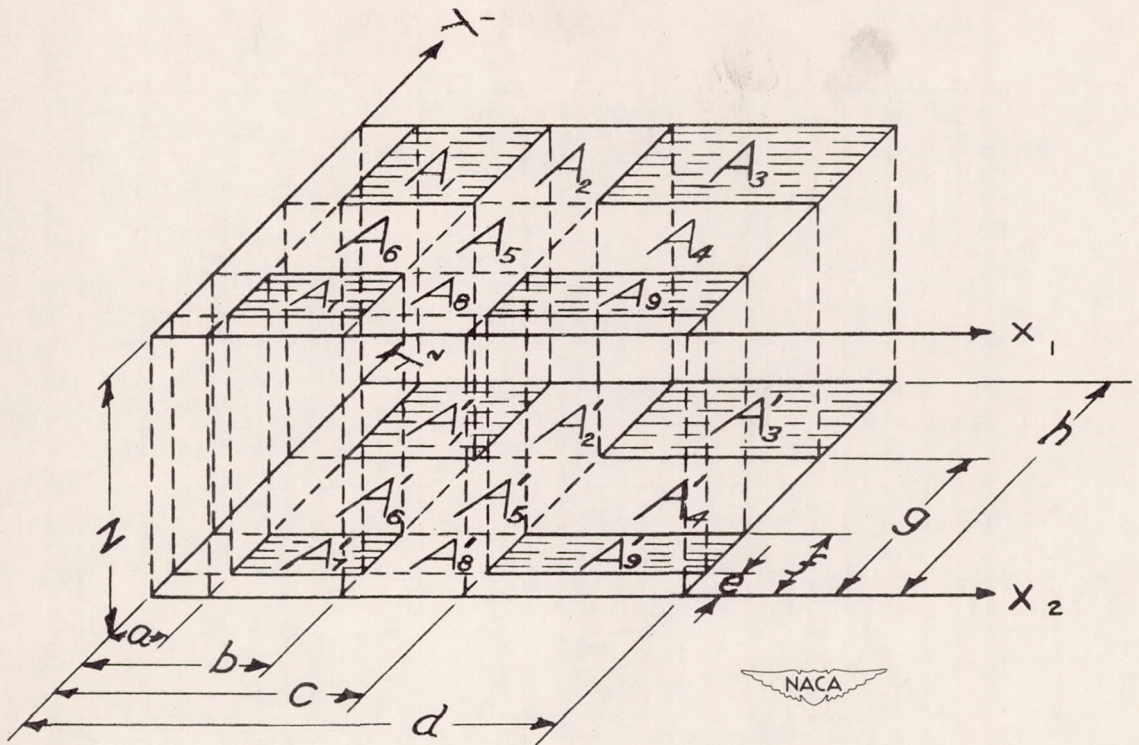


Figure 9.- Geometry of configuration A-3.

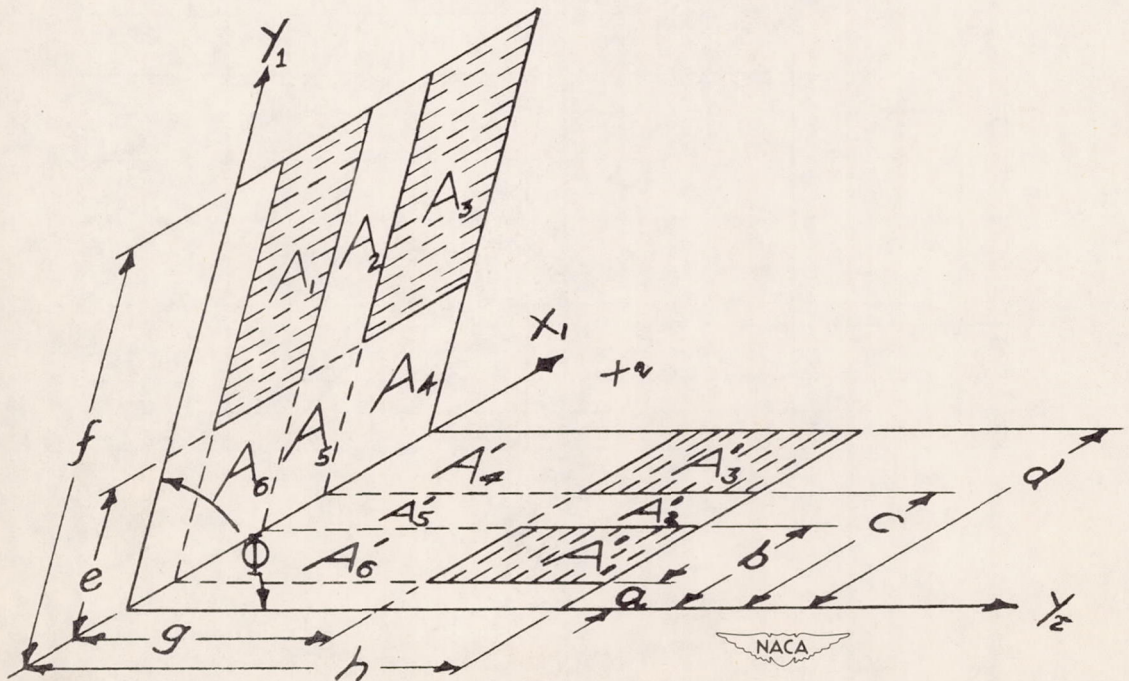


Figure 10.- Geometry of configuration A-4.

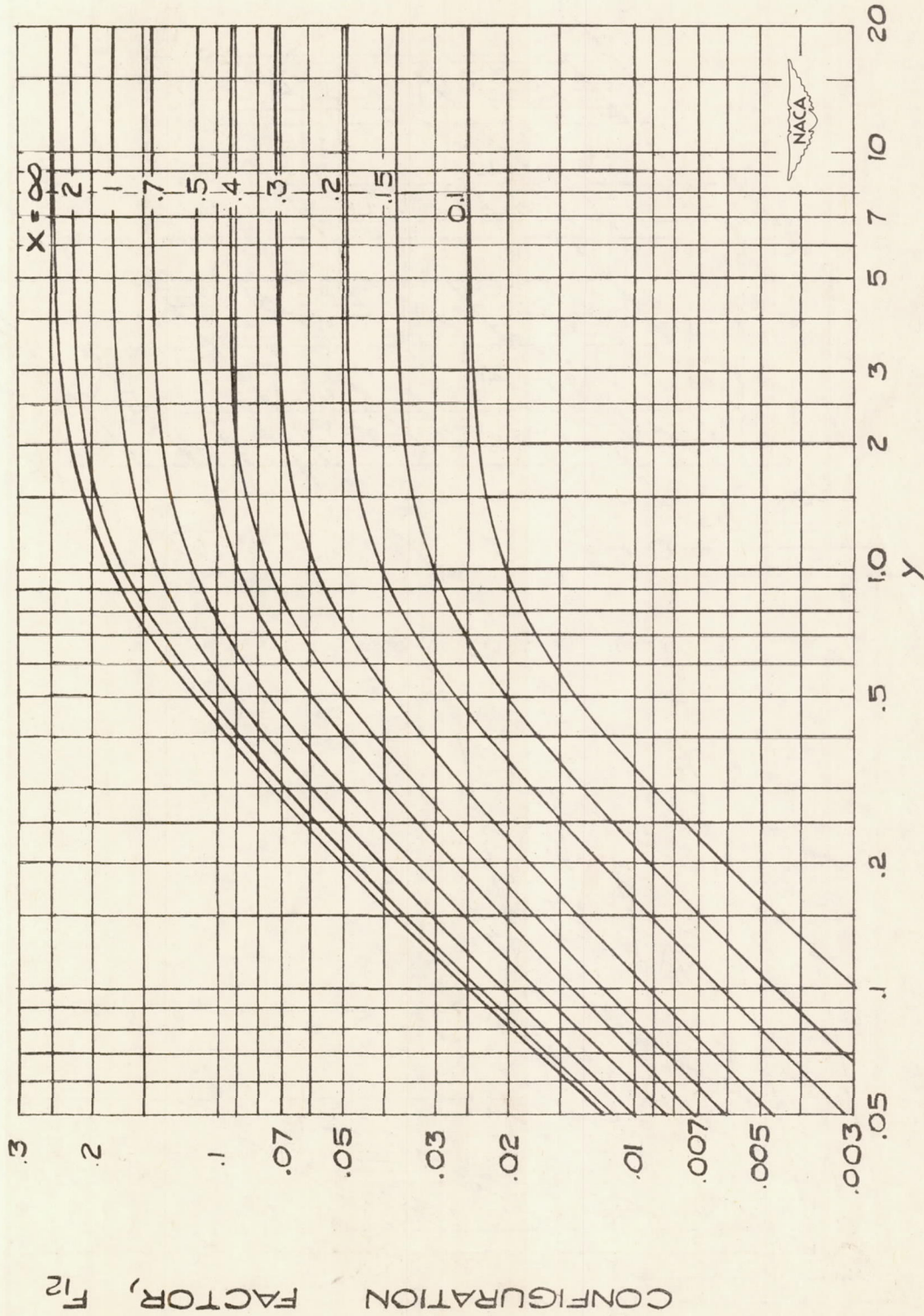
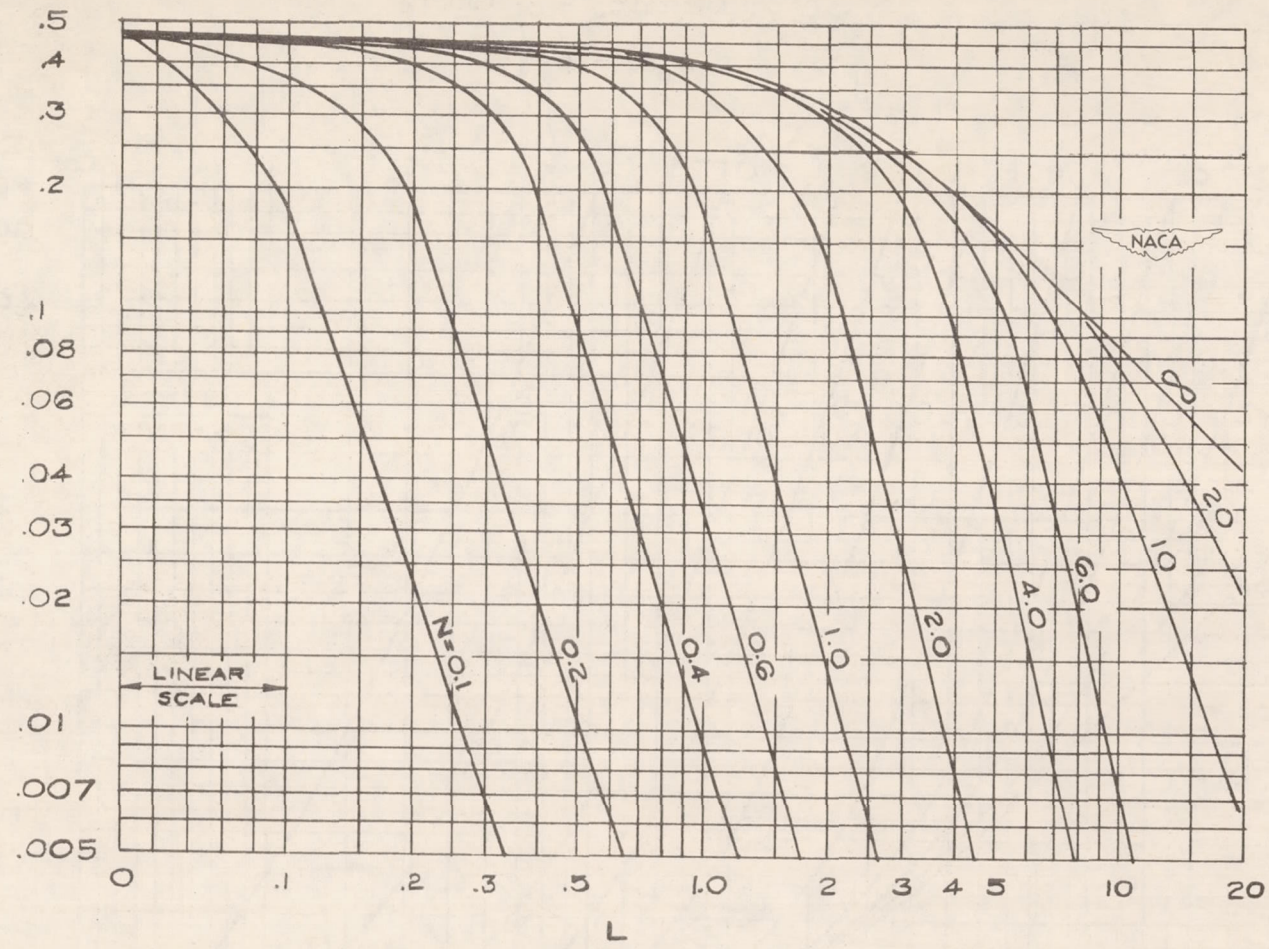


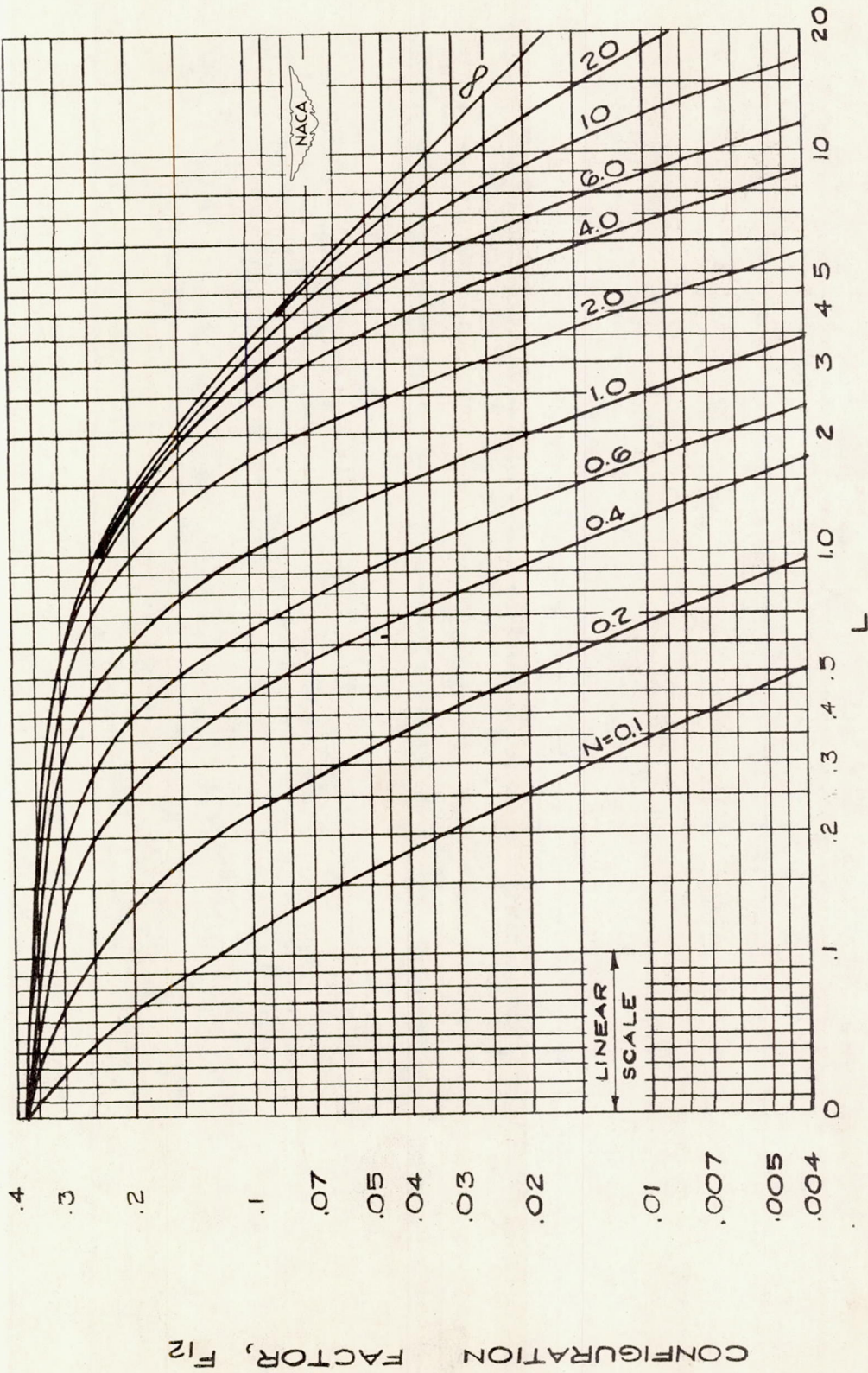
Figure 11.- Configuration-factor curves for configuration P-1.

CONFIGURATION FACTOR, F_{12}



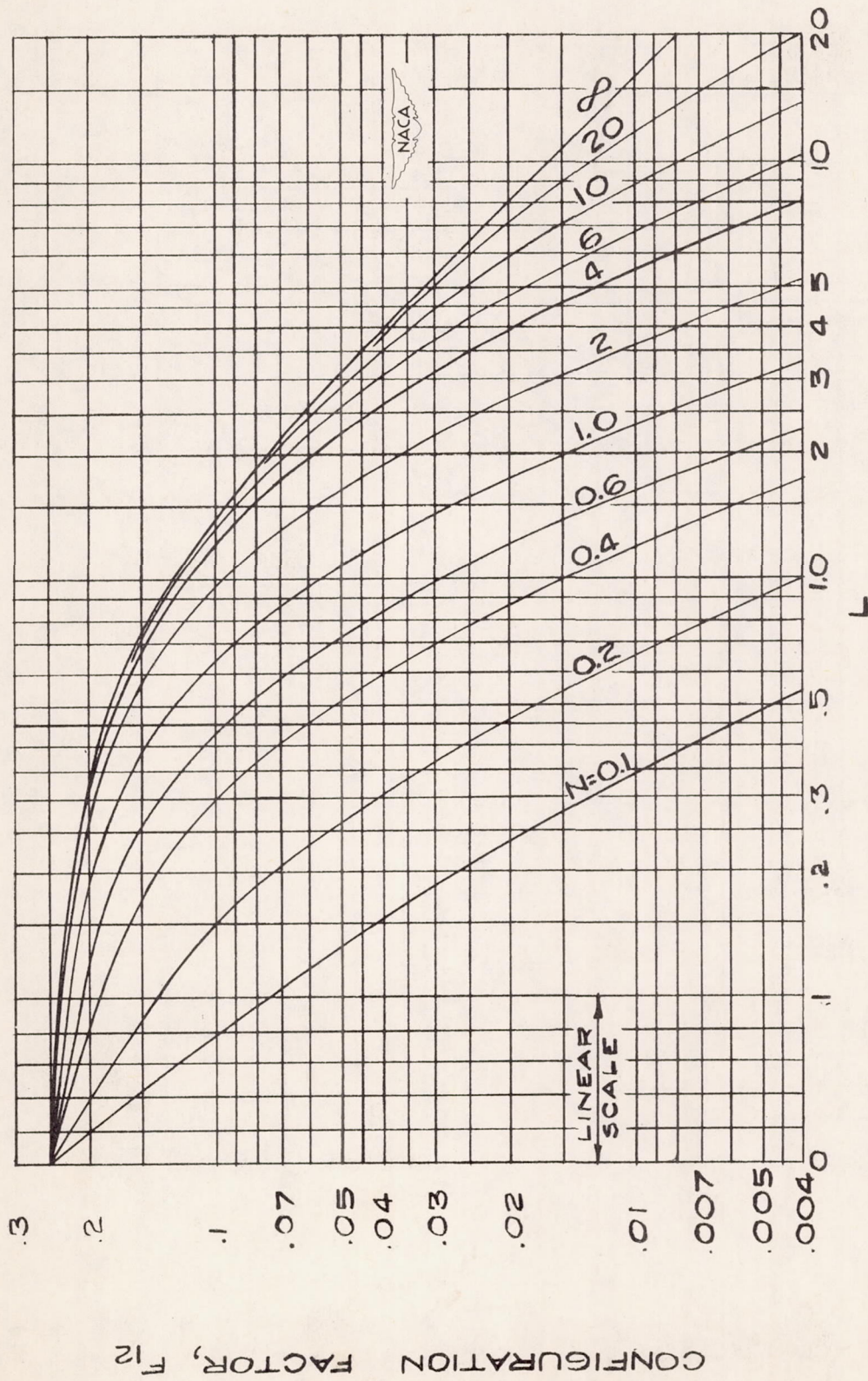
(a) $\phi = 30^\circ$.

Figure 12.- Configuration-factor curves for configuration P-2 for various values of ϕ . When $\phi = 0^\circ$, $F_{12} = 0$ for $N < L$ and 0.5 for $N > L$; when $\phi = 180^\circ$, $F_{12} = 0$ for all values of N and L .



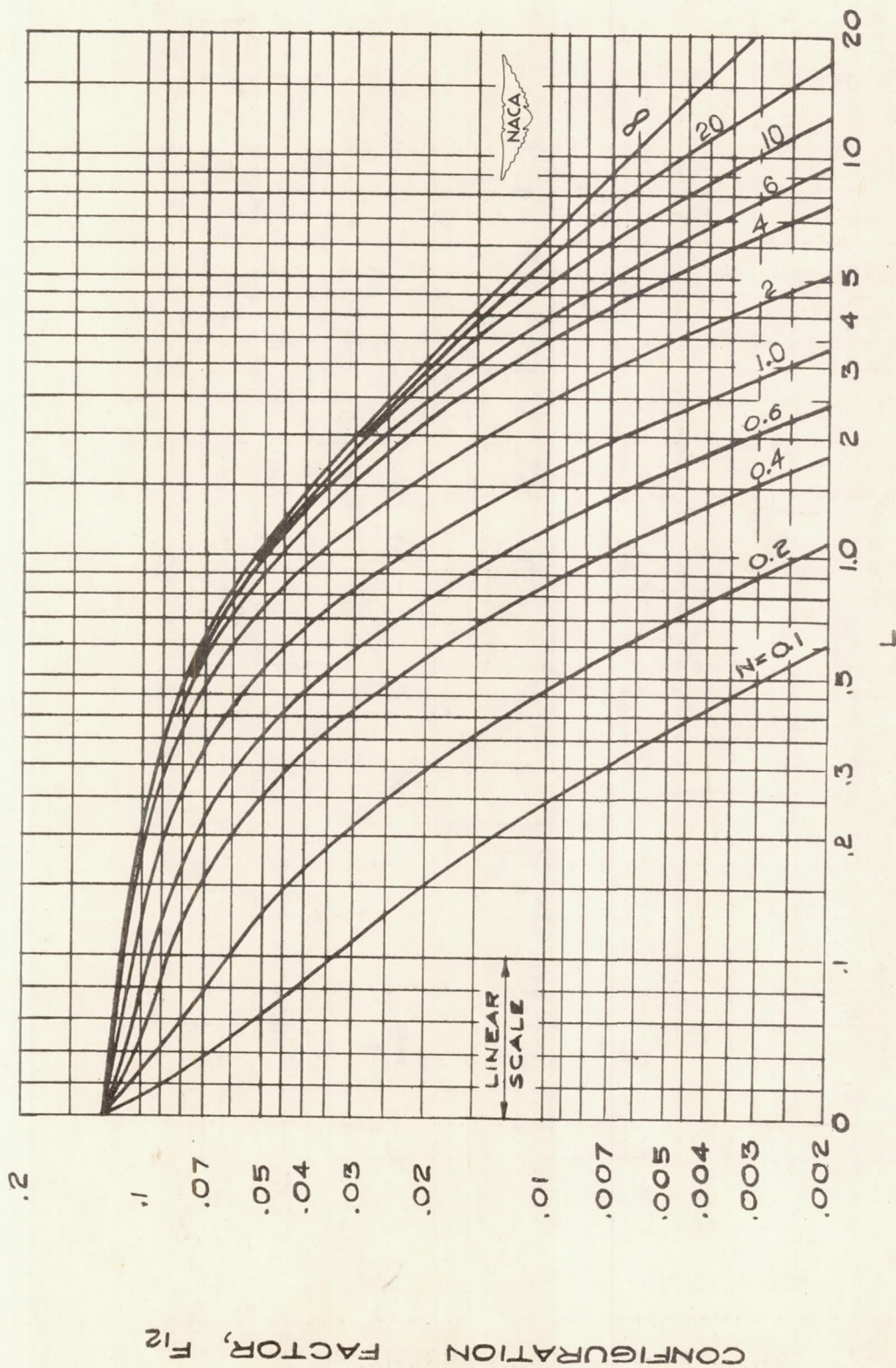
(b) $\phi = 60^\circ$.

Figure 12.- Continued.



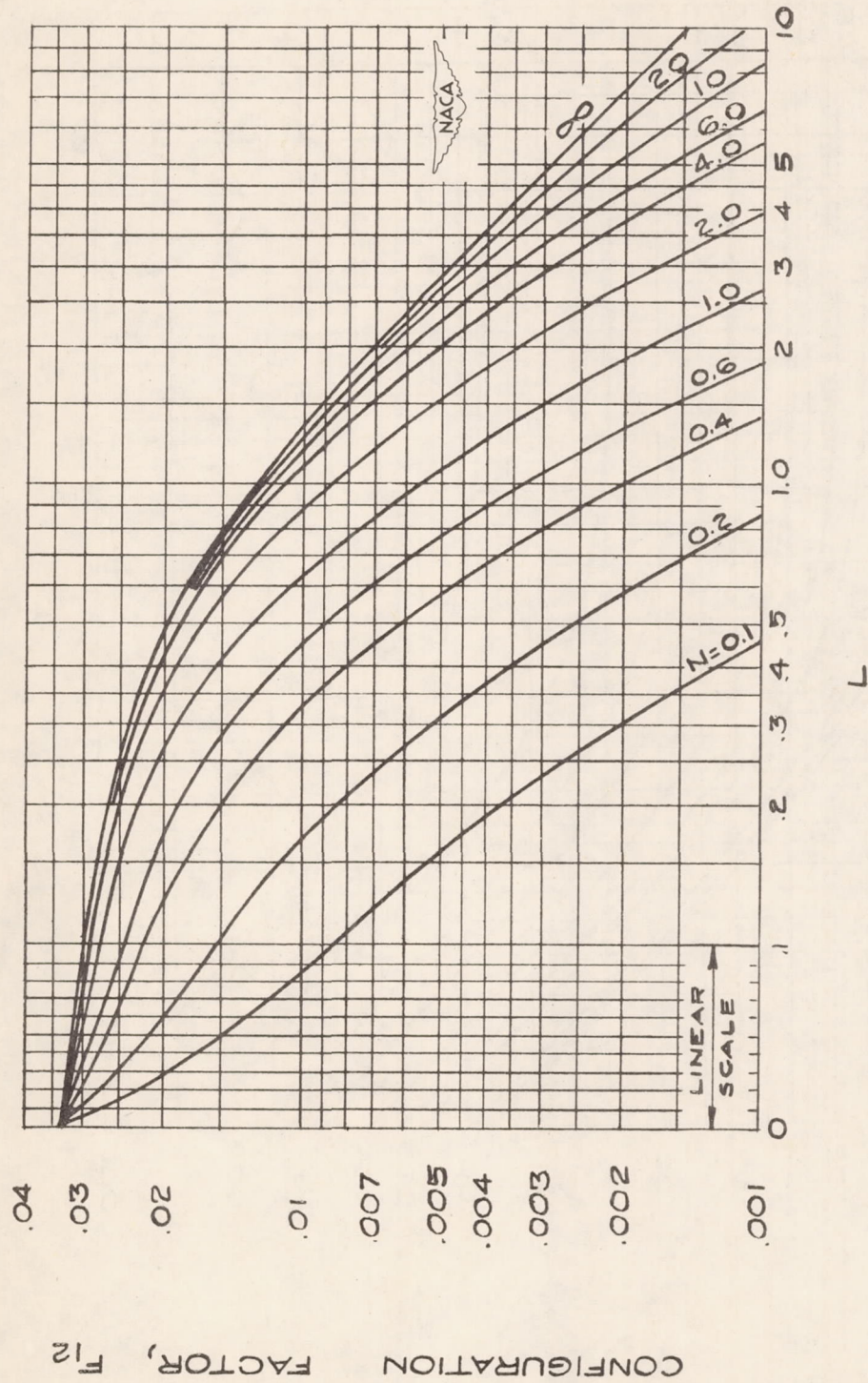
(c) $\phi = 90^\circ$.

Figure 12.- Continued.



(a) $\phi = 120^\circ$.

Figure 12.- Continued.



(e) $\phi = 150^\circ$.

Figure 12.- Concluded.

CONFIGURATION FACTOR, F_{12}

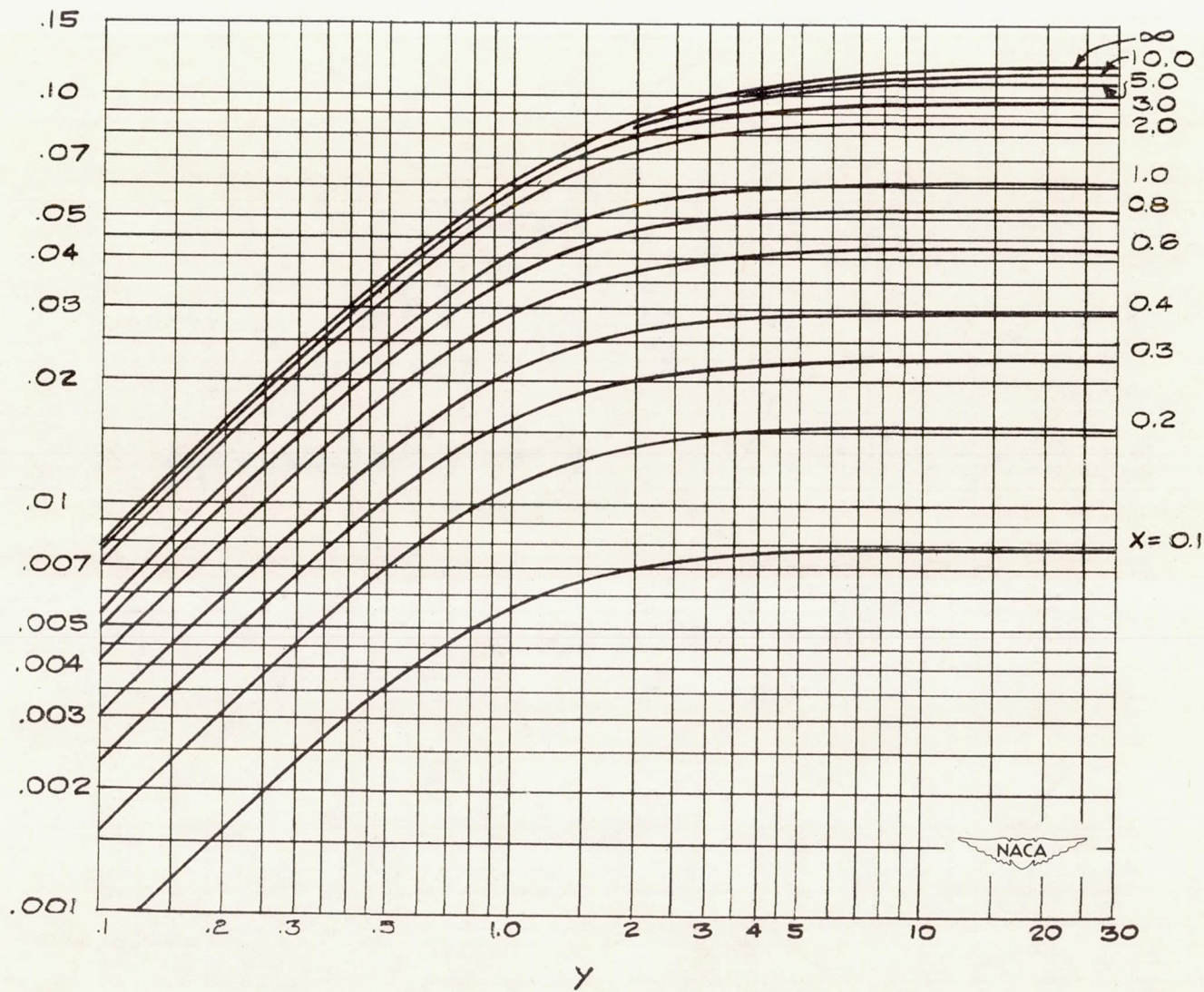


Figure 13.- Configuration-factor curves for configuration P-5.

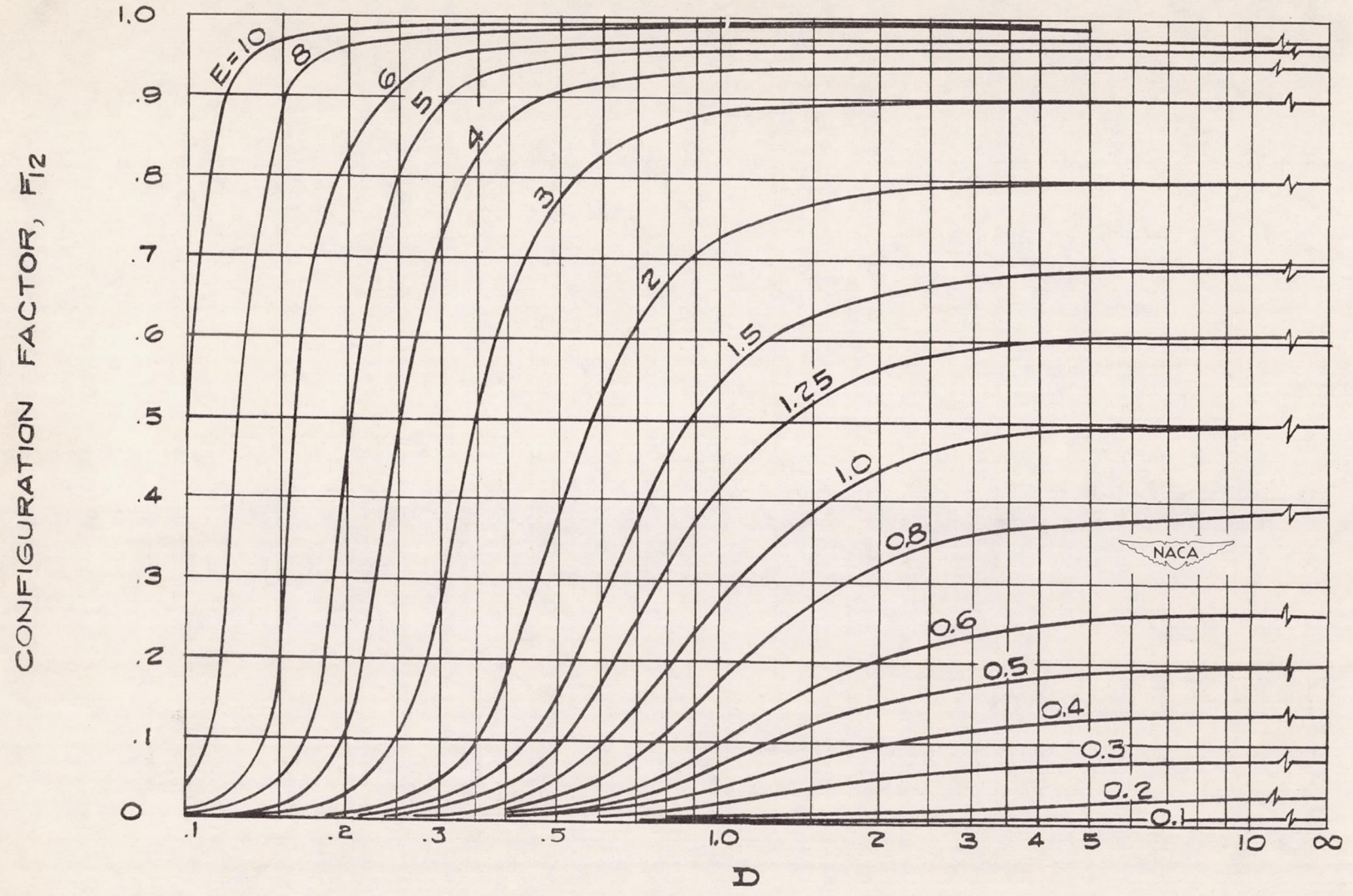


Figure 14.- Configuration-factor curves for configuration P-6.

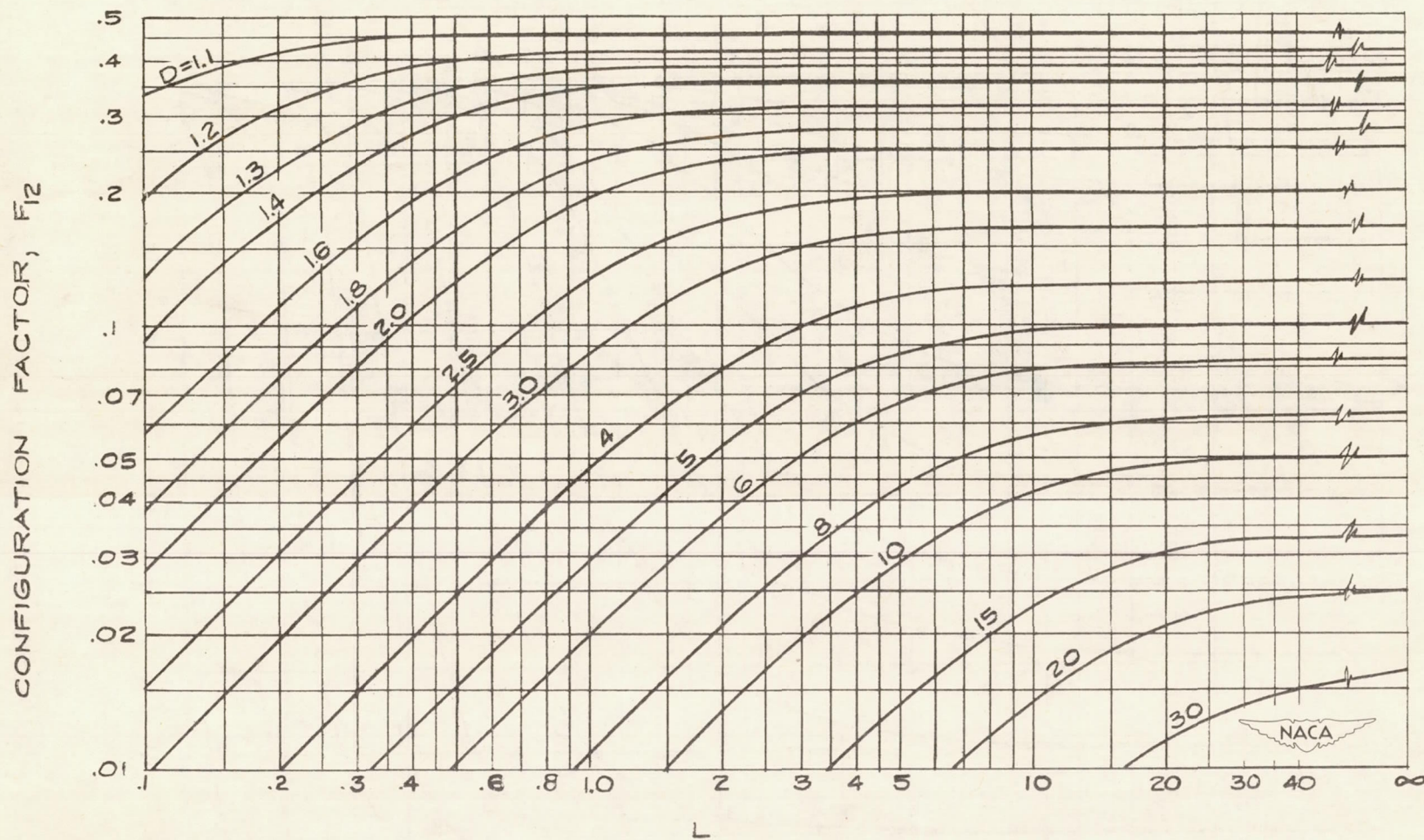


Figure 15.- Configuration-factor curves for configuration P-8.

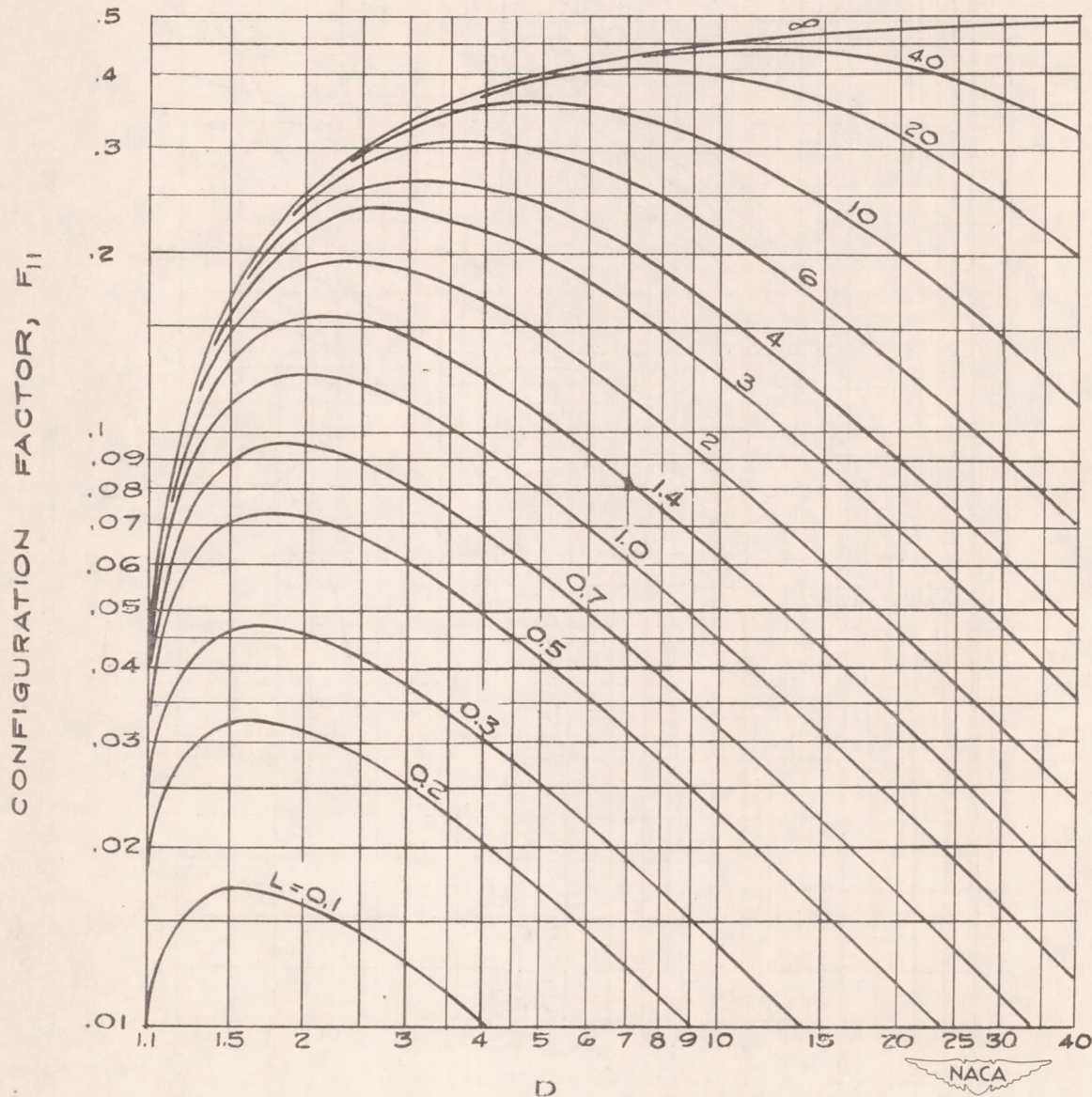


Figure 16.- Configuration-factor curves for configuration P-9.

CONFIGURATION FACTOR, F_{12}

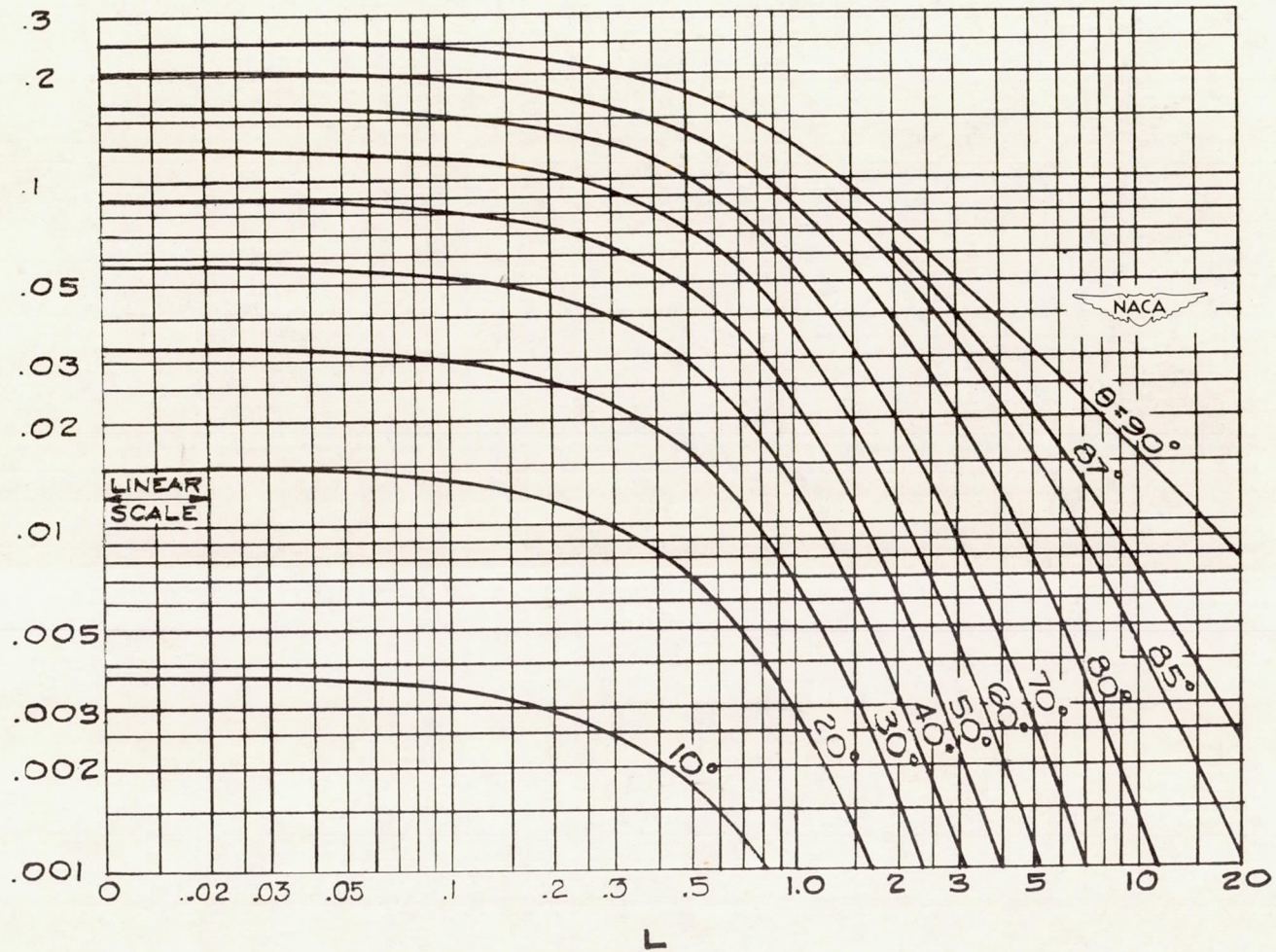


Figure 17.- Configuration-factor curves for configuration P-10 with $\phi = 90^\circ$.

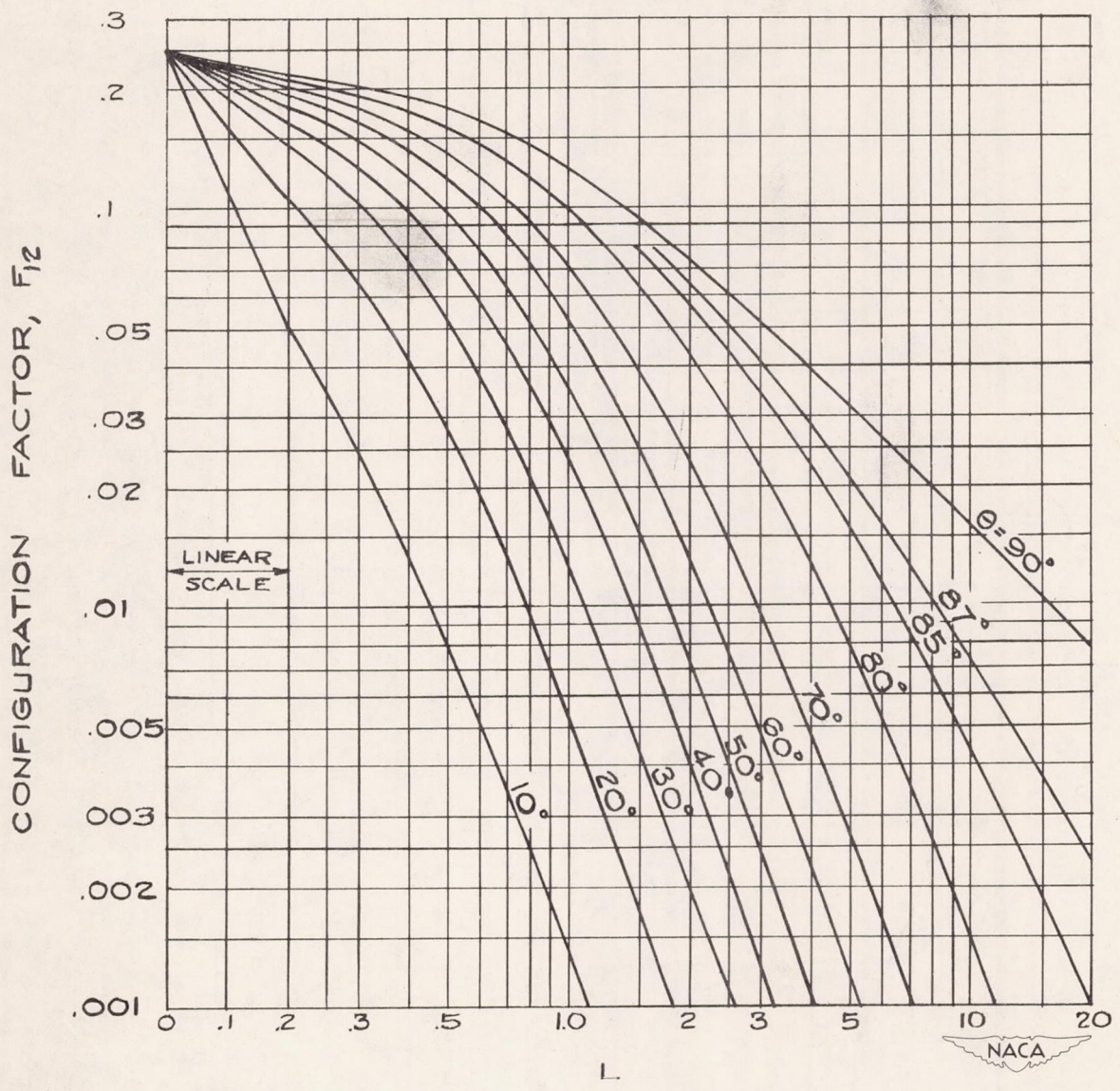
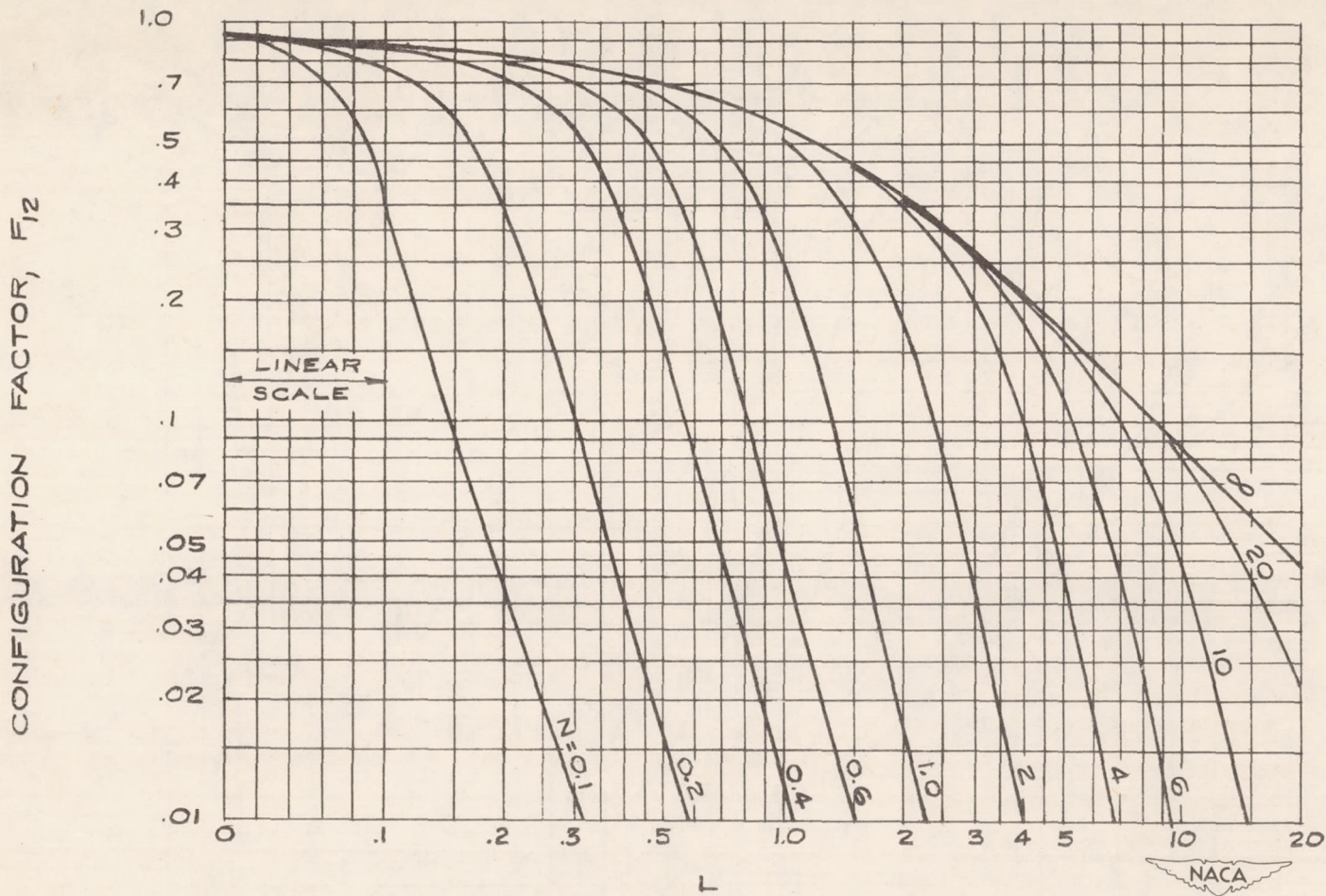
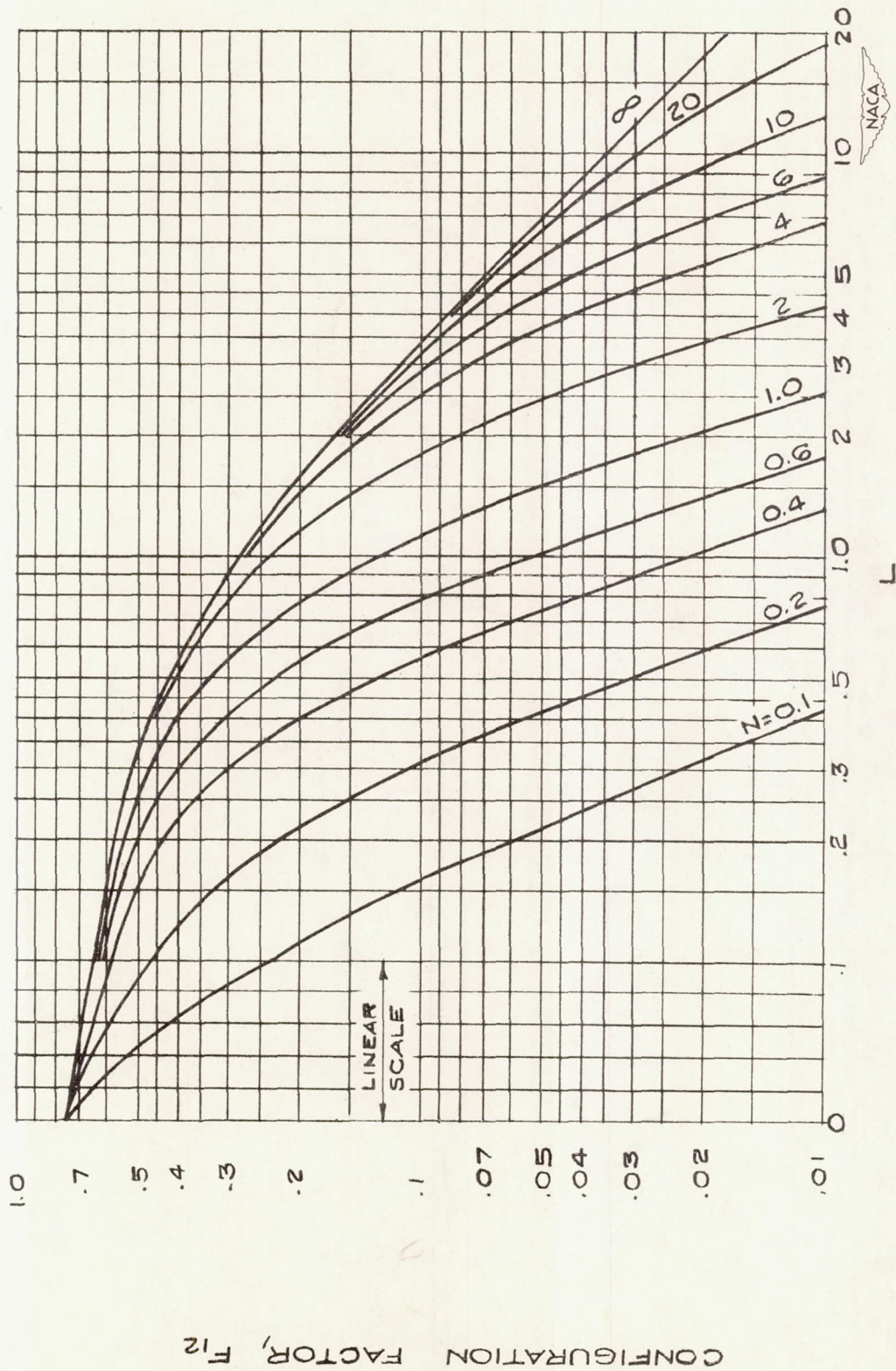


Figure 18.- Configuration-factor curves for configuration P-11 with $\phi = 90^\circ$.



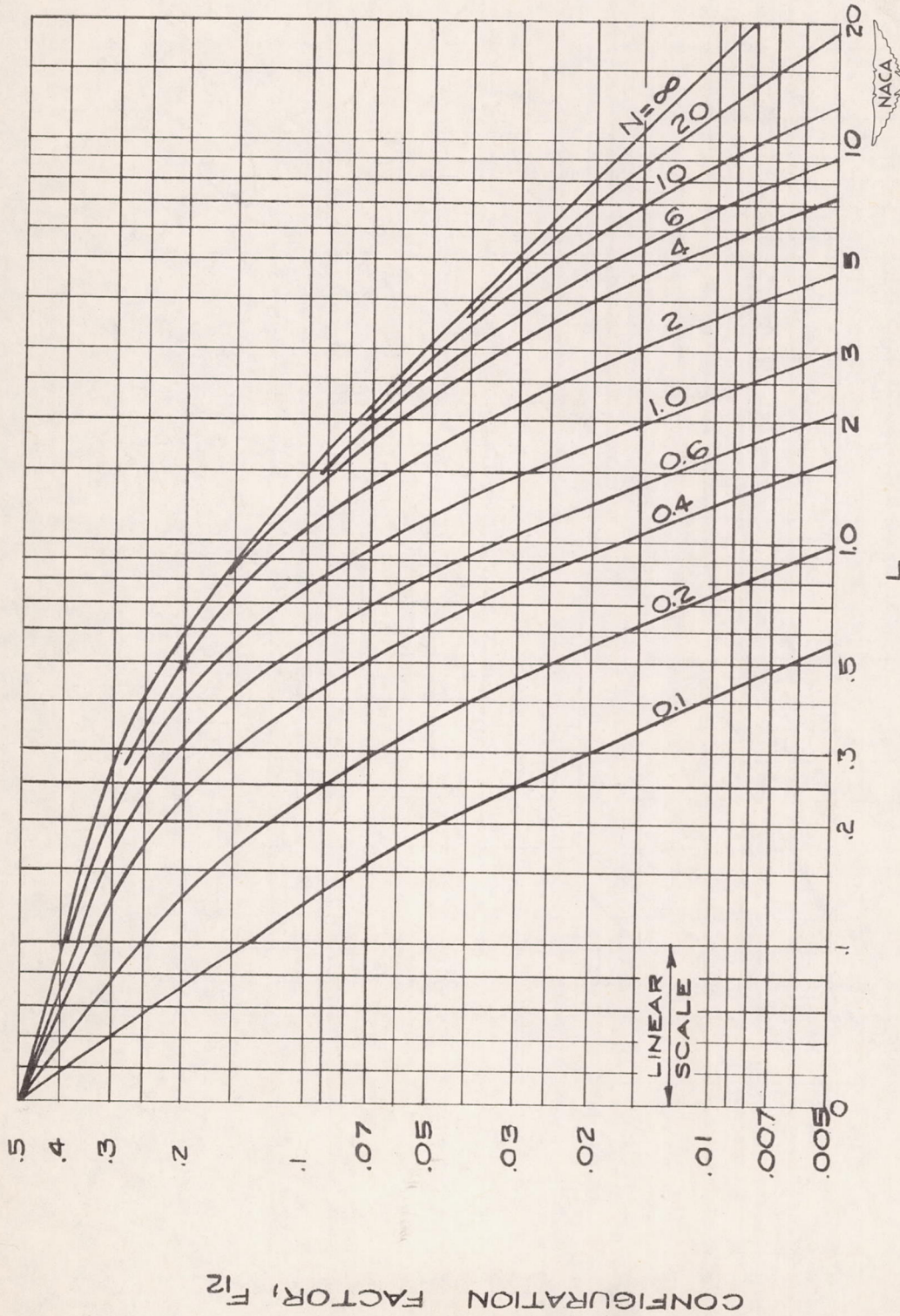
(a) $\phi = 30^\circ$.

Figure 20.- Configuration-factor curves for configuration L-2 for various values of ϕ . When $\phi = 0^\circ$, $F_{12} = 0$ for $N < L$ and 1 for $N > L$; when $\phi = 180^\circ$, $F_{12} = 0$ for all values of N and L .



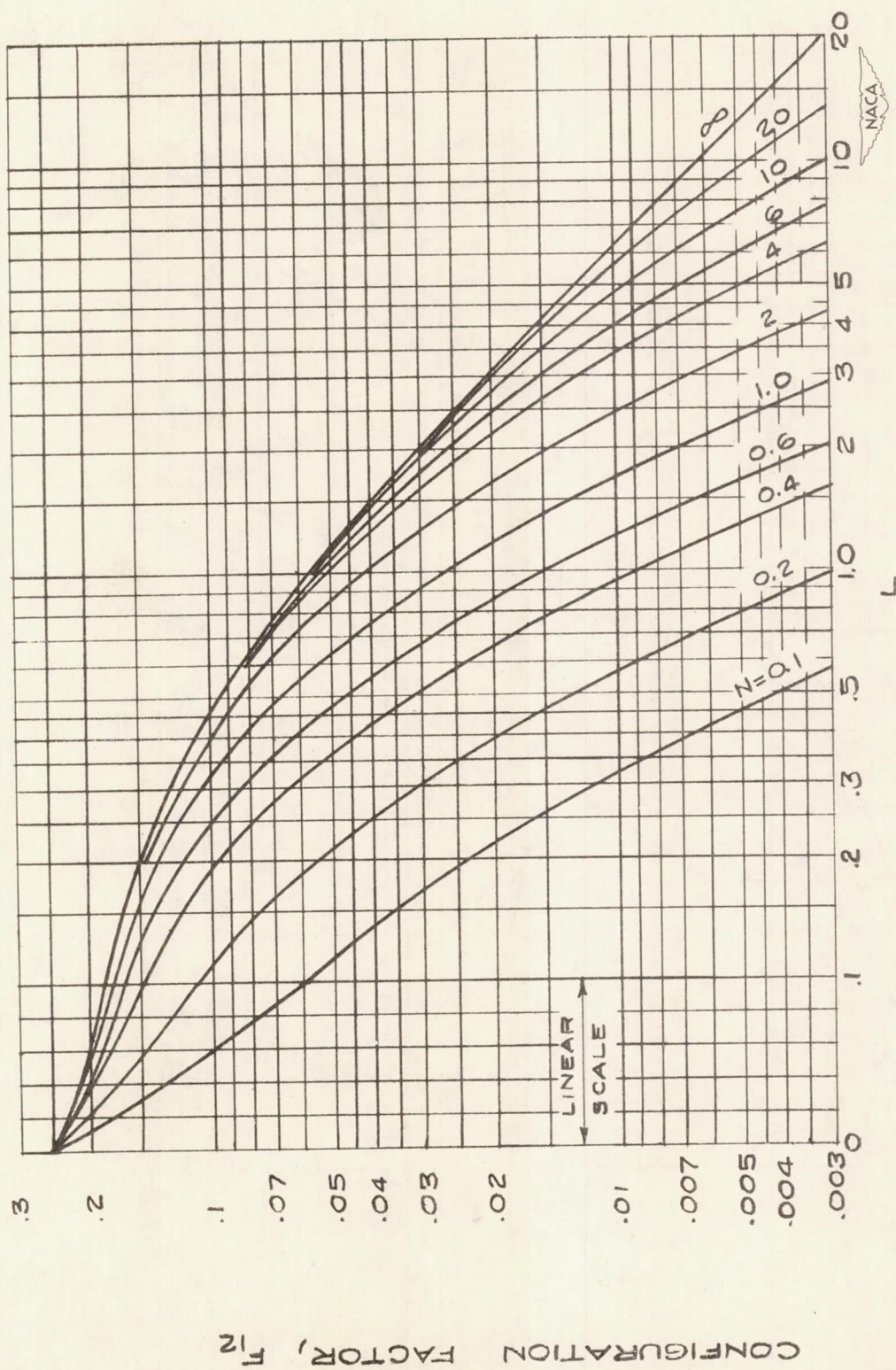
(b) $\phi = 60^\circ$.

Figure 20.- Continued.



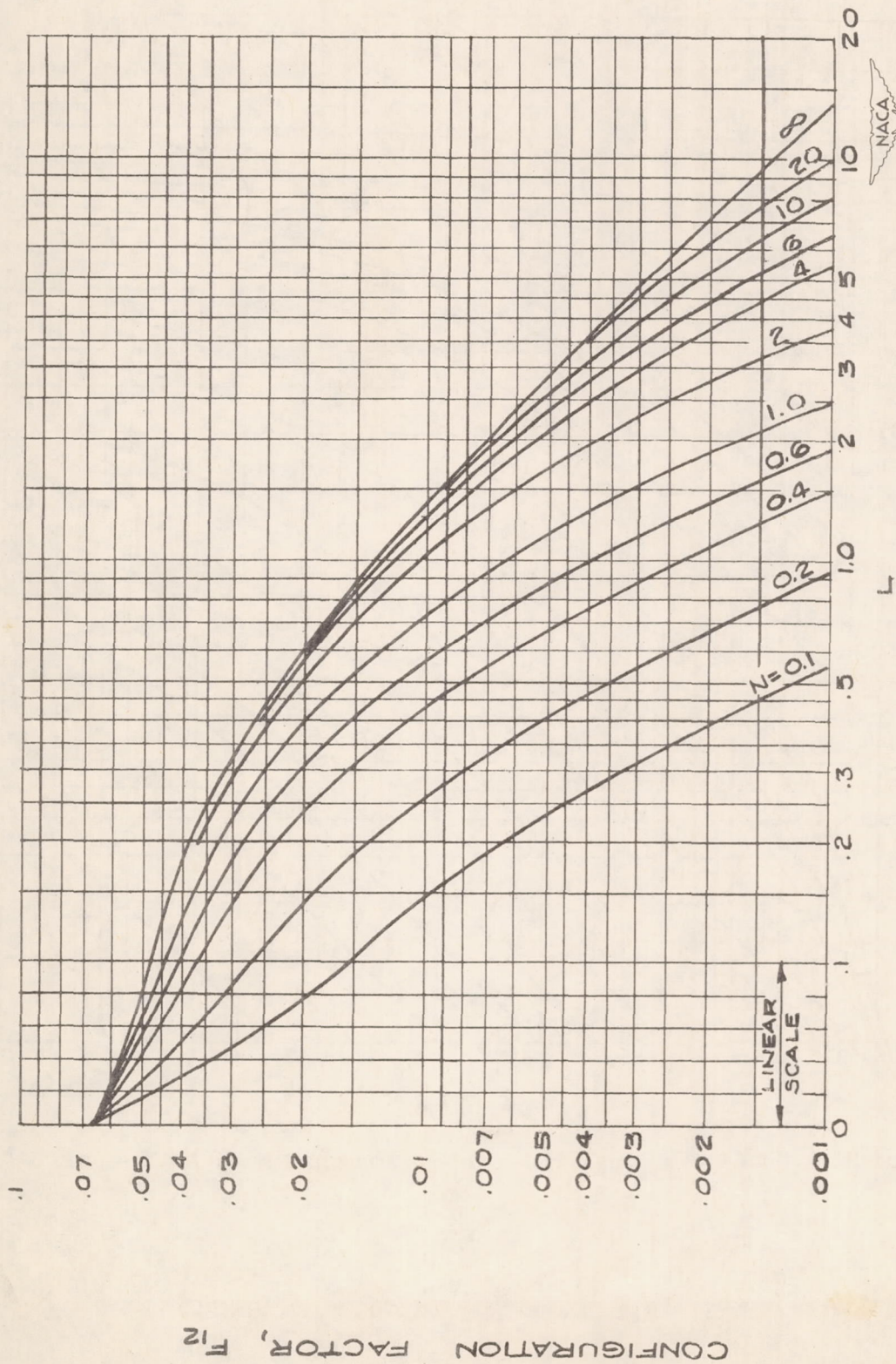
(c) $\phi = 90^\circ$.

Figure 20.- Continued.



(d) $\phi = 120^\circ$.

Figure 20.- Continued.



(e) $\phi = 150^\circ$.

Figure 20.- Concluded.

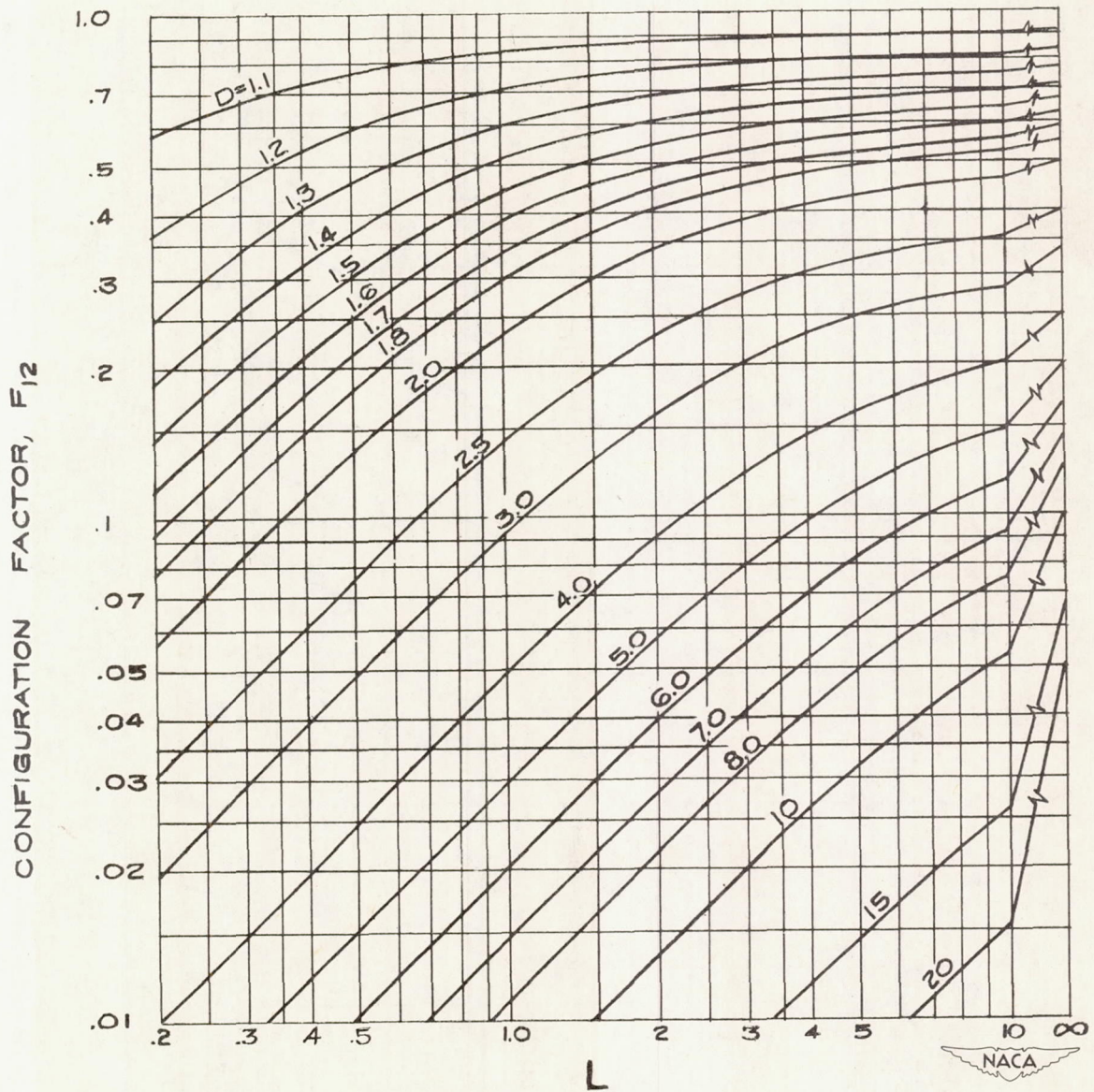


Figure 21.- Configuration-factor curves for configuration L-3 or A-7.

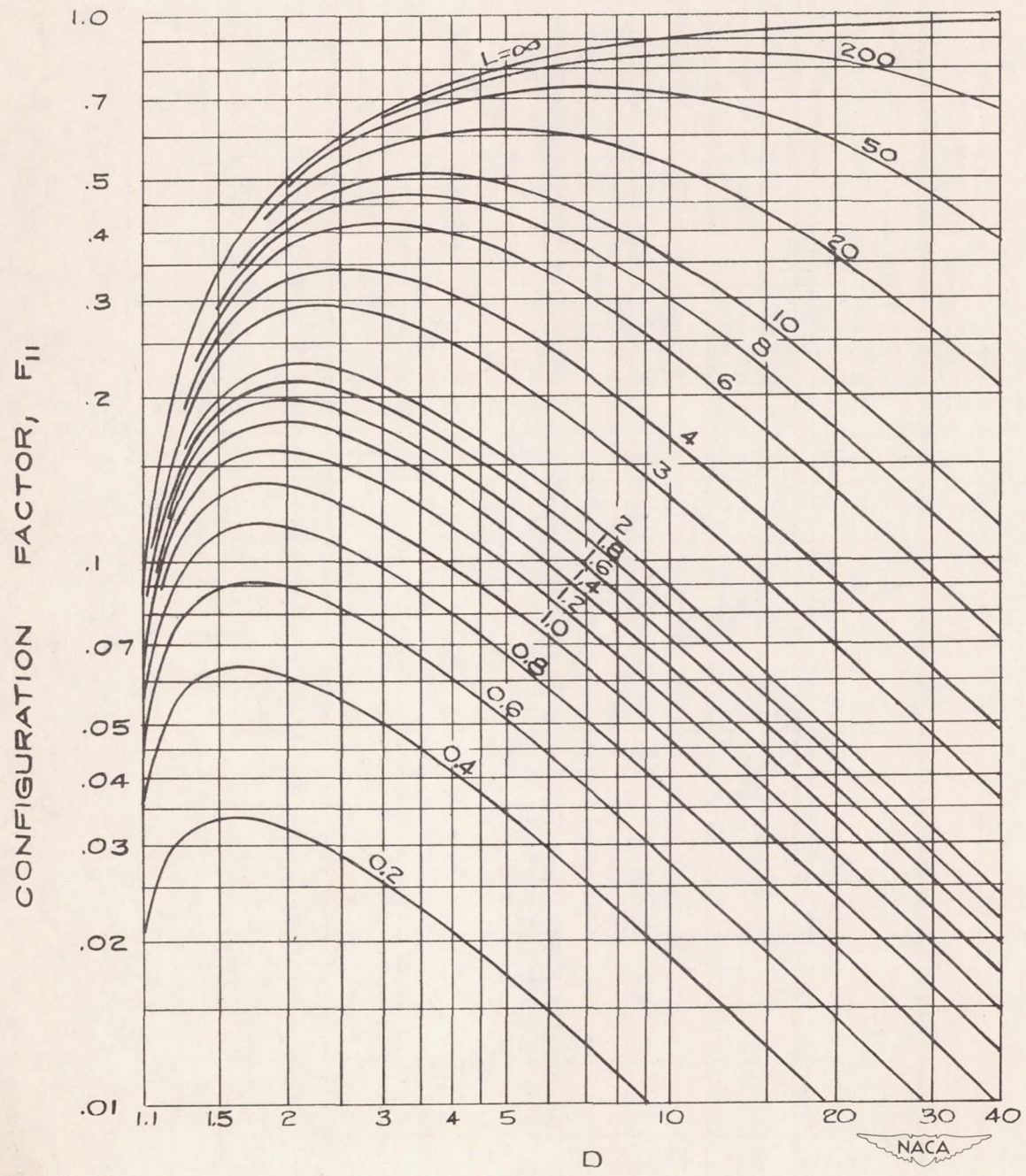


Figure 22.- Configuration-factor curves for configuration L-4 or A-8.

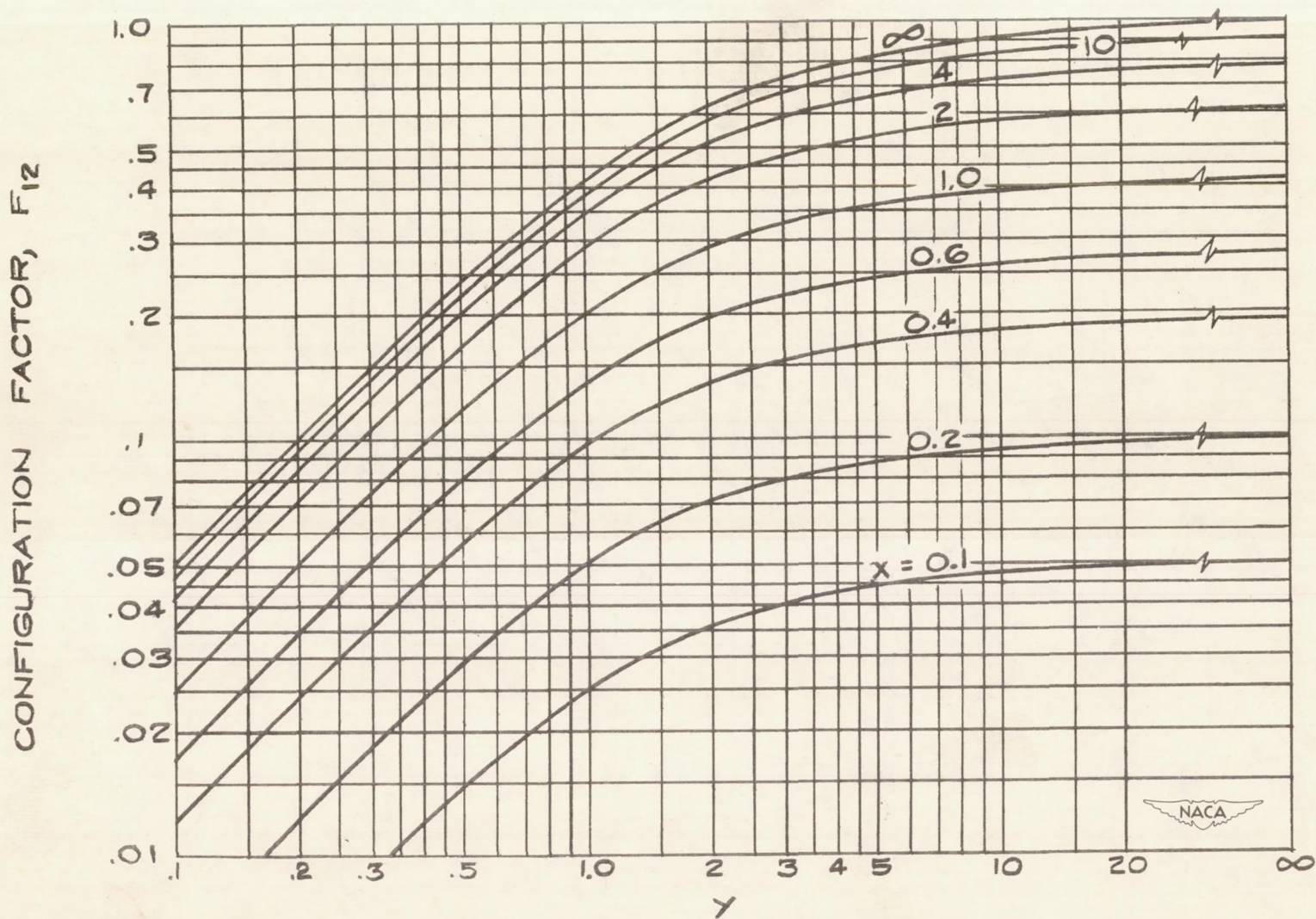
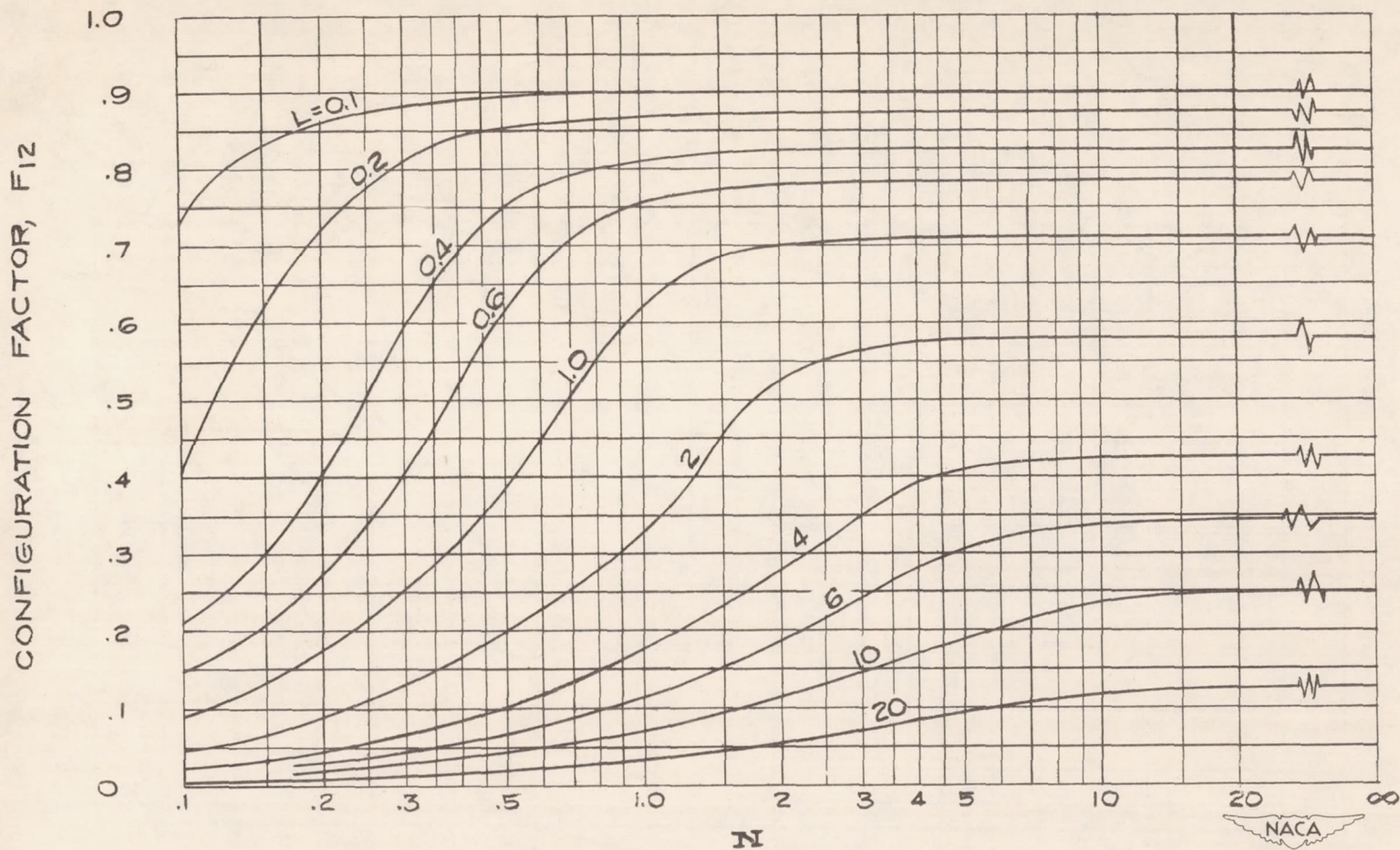
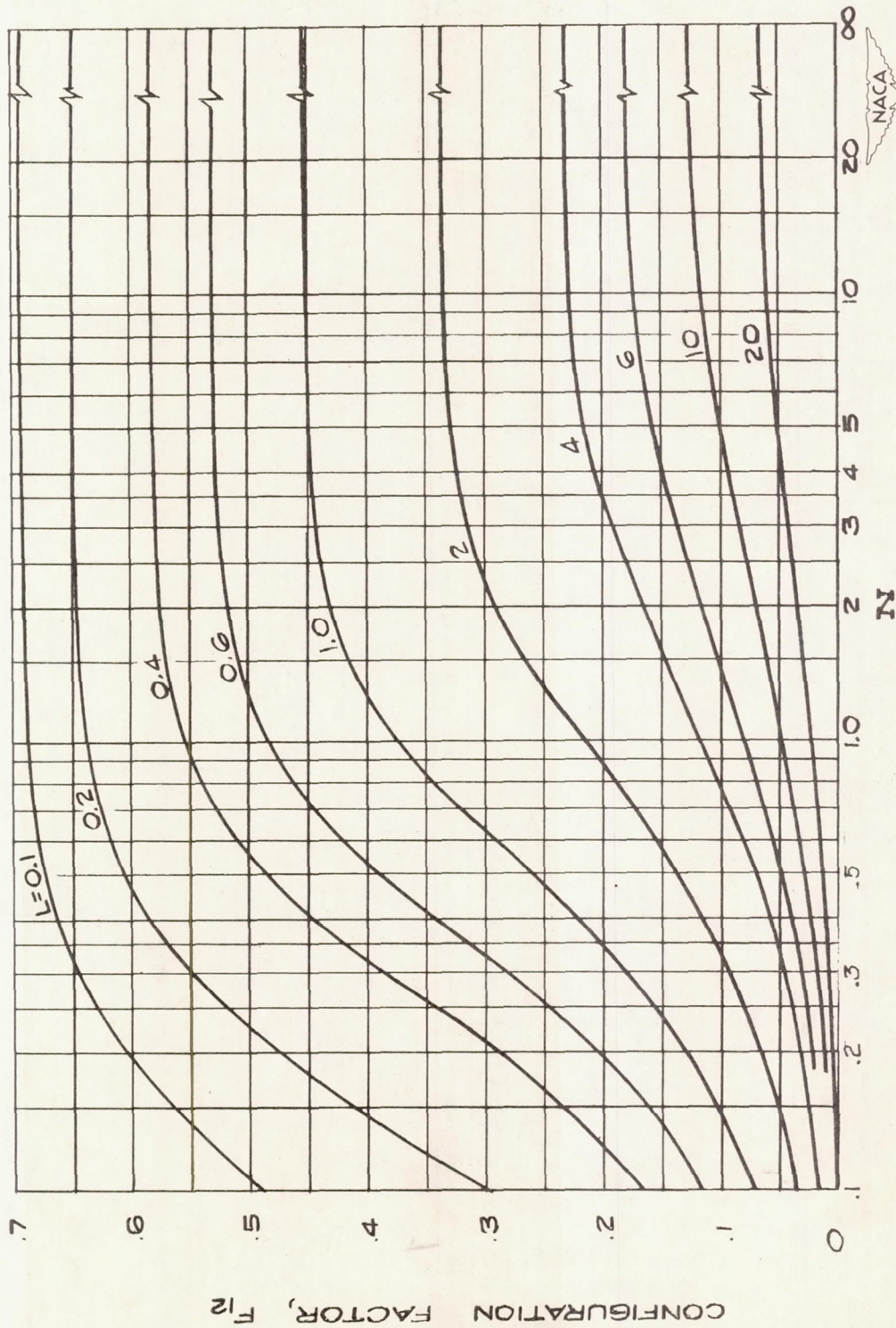


Figure 23.- Configuration-factor curves for configuration A-1.



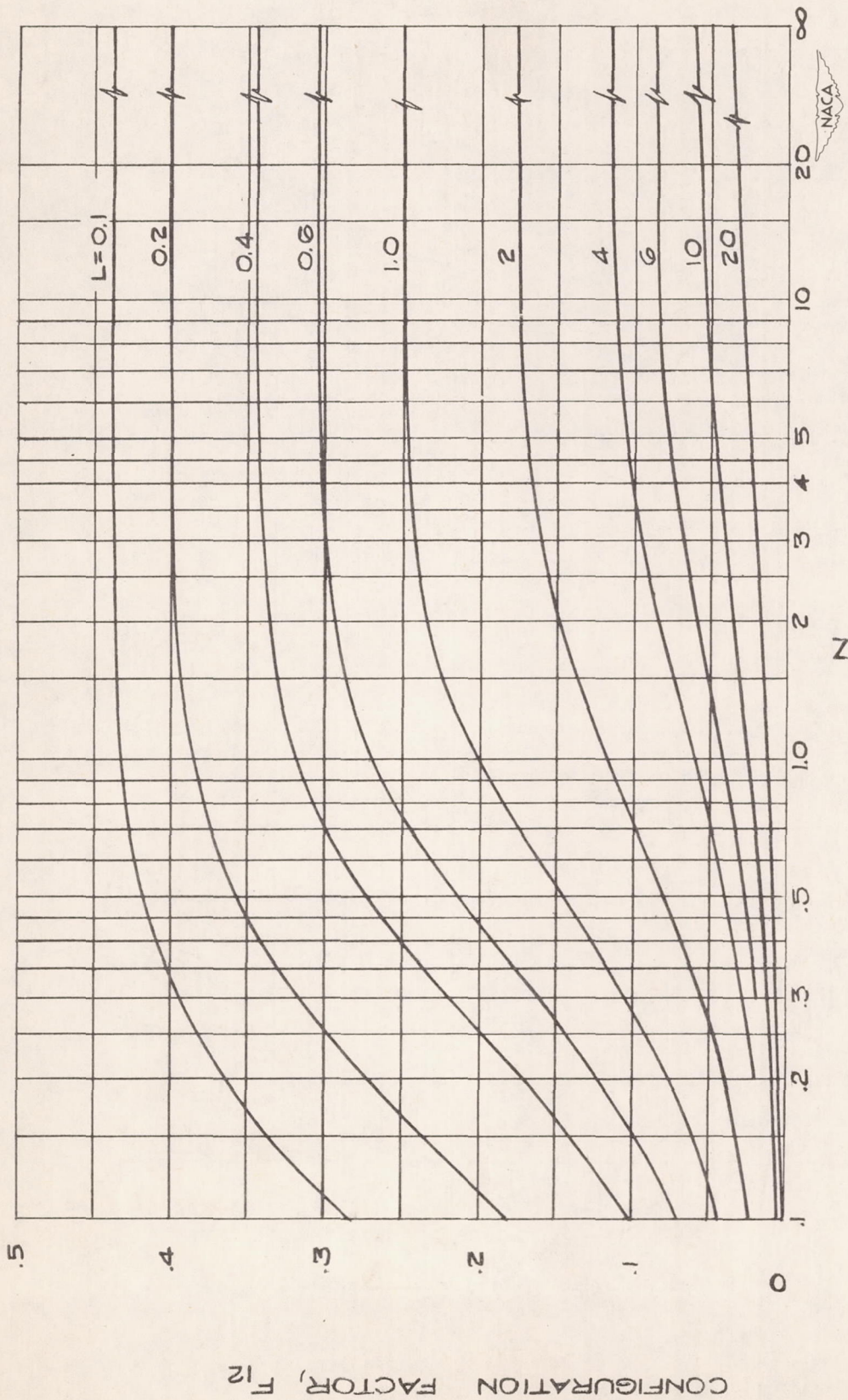
(a) $\phi = 30^\circ$.

Figure 24.- Configuration-factor curves for configuration A-2 for various values of ϕ . When $\phi = 0^\circ$, $F_{12} = N/L$ for $N < L$ and 1 for $N > L$; when $\phi = 180^\circ$, $F_{12} = 0$ for all values of N and L .



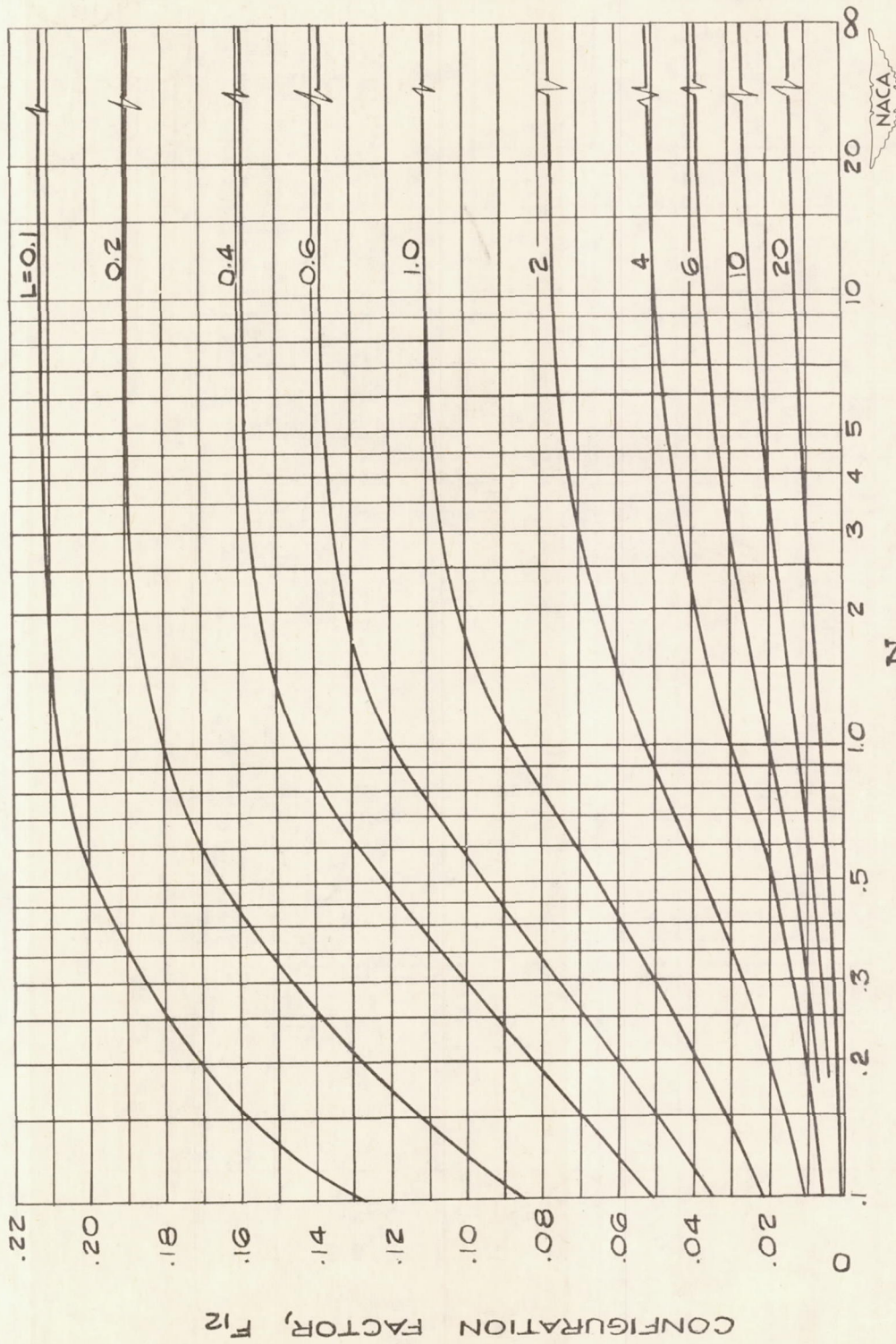
(b) $\phi = 60^\circ$.

Figure 24.- Continued.



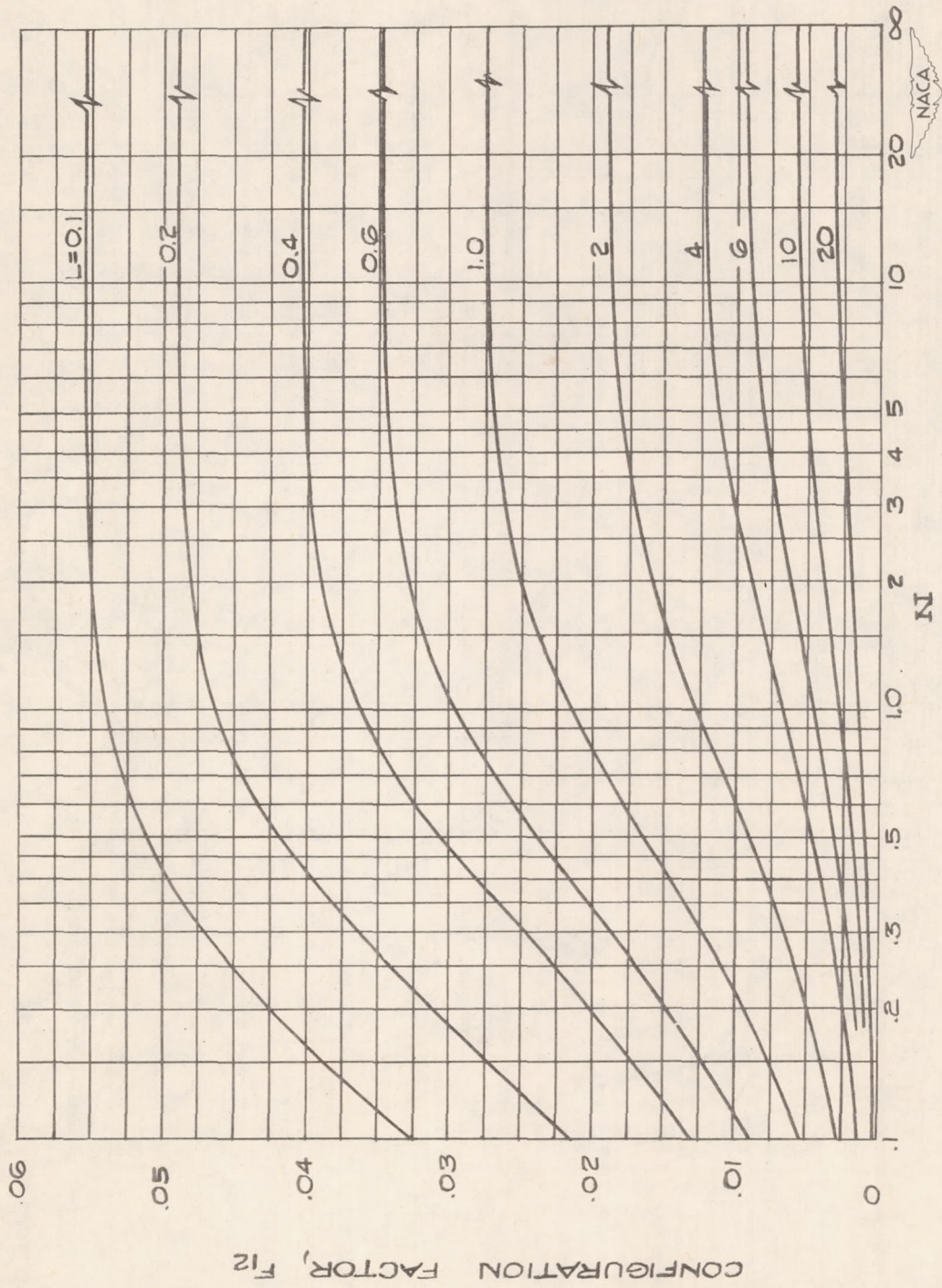
(c) $\phi = 90^\circ$.

Figure 24.- Continued.



(d) $\phi = 120^\circ$.

Figure 24. - Continued.



(e) $\phi = 150^\circ$.

Figure 24.- Concluded.

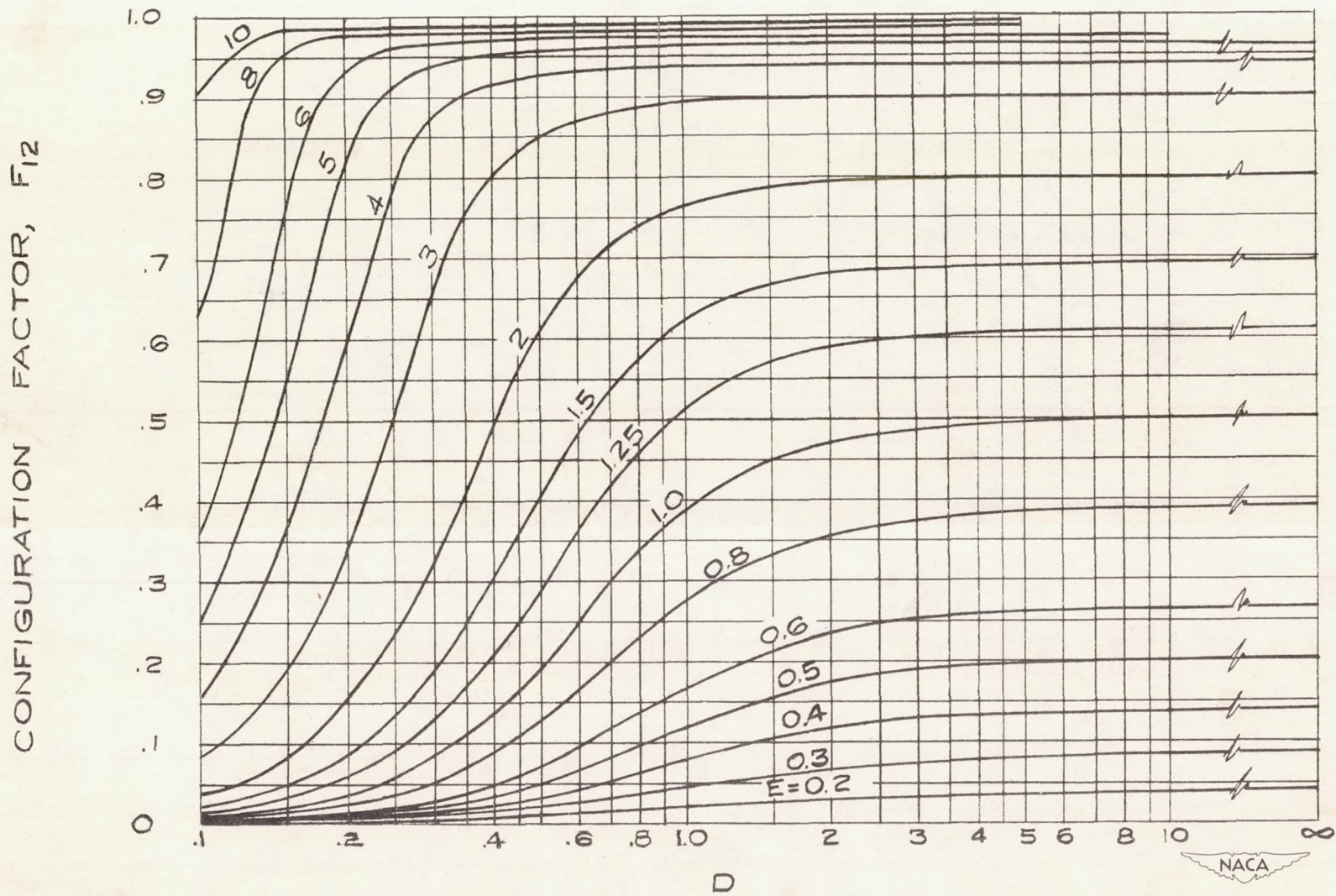


Figure 25.- Configuration-factor curves for configuration A-5.

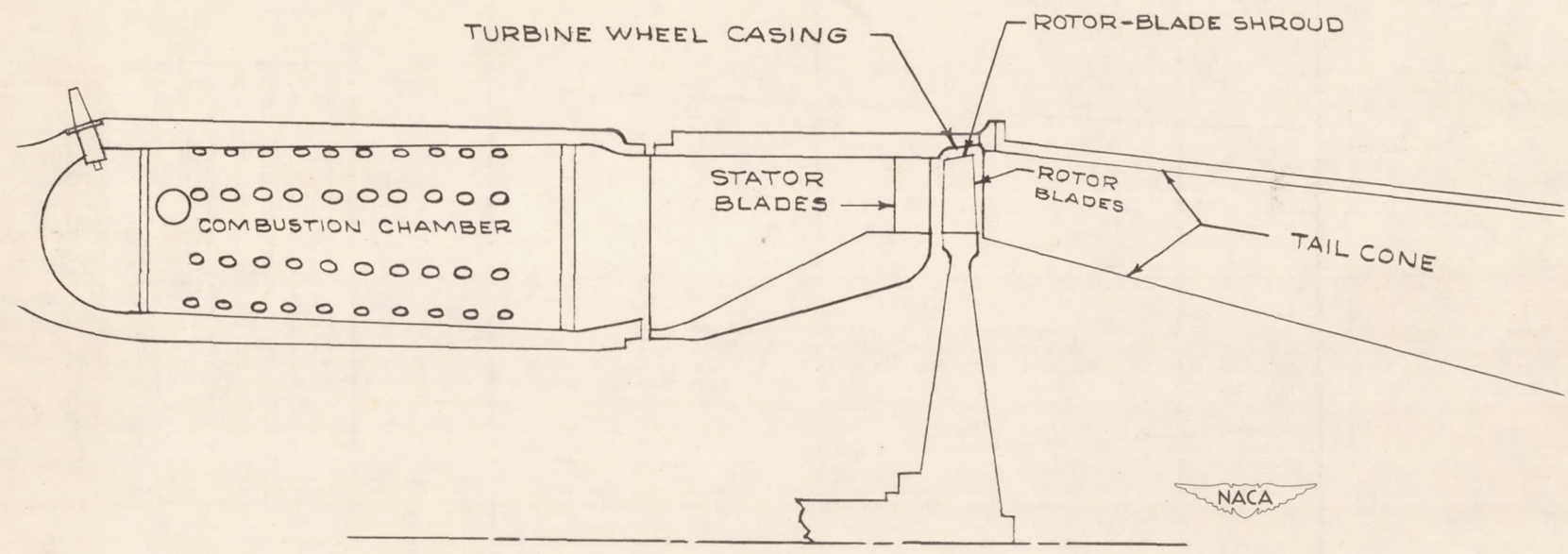


Figure 26.- Cross section of gas turbine.

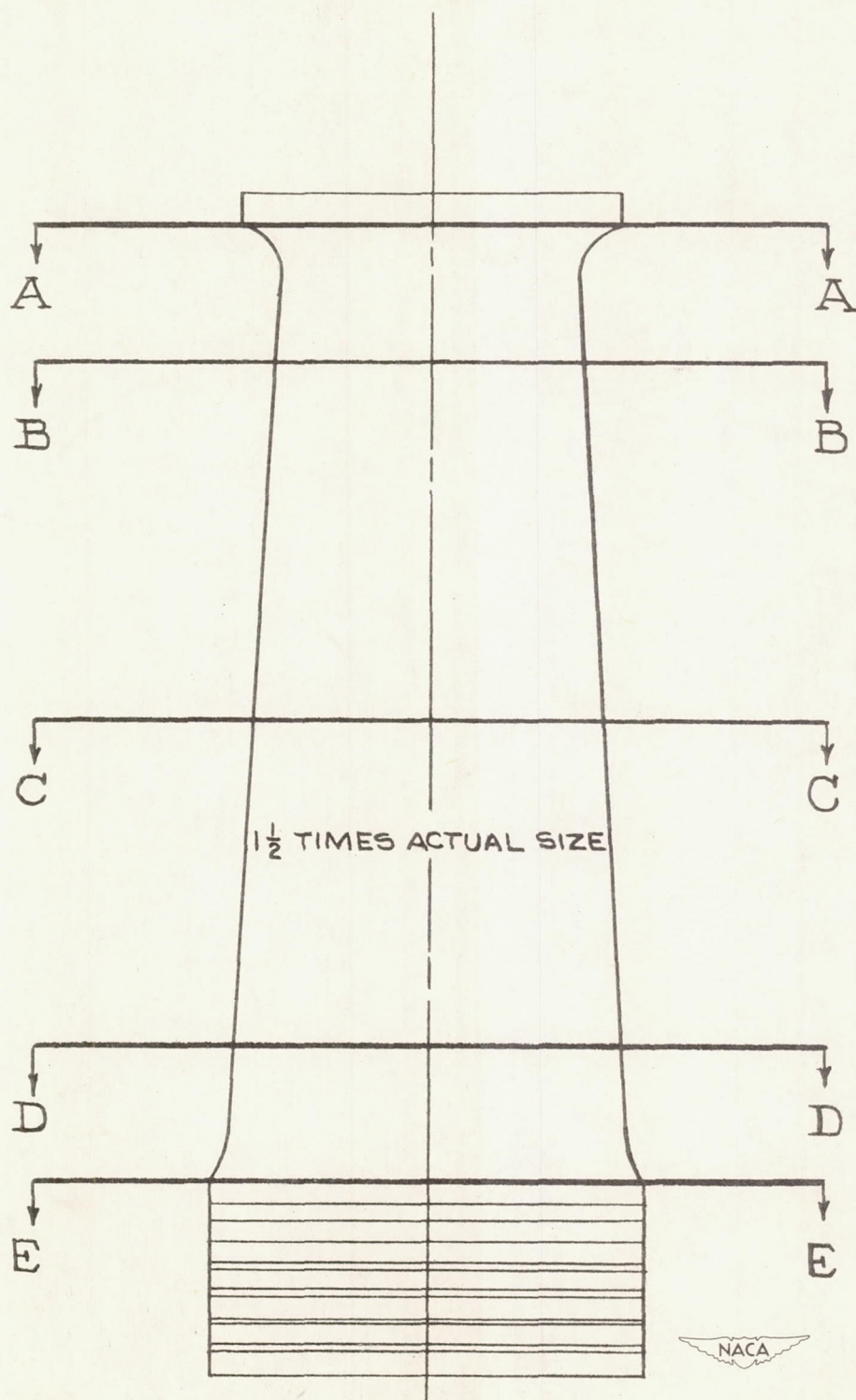


Figure 27.- Rotor blade.

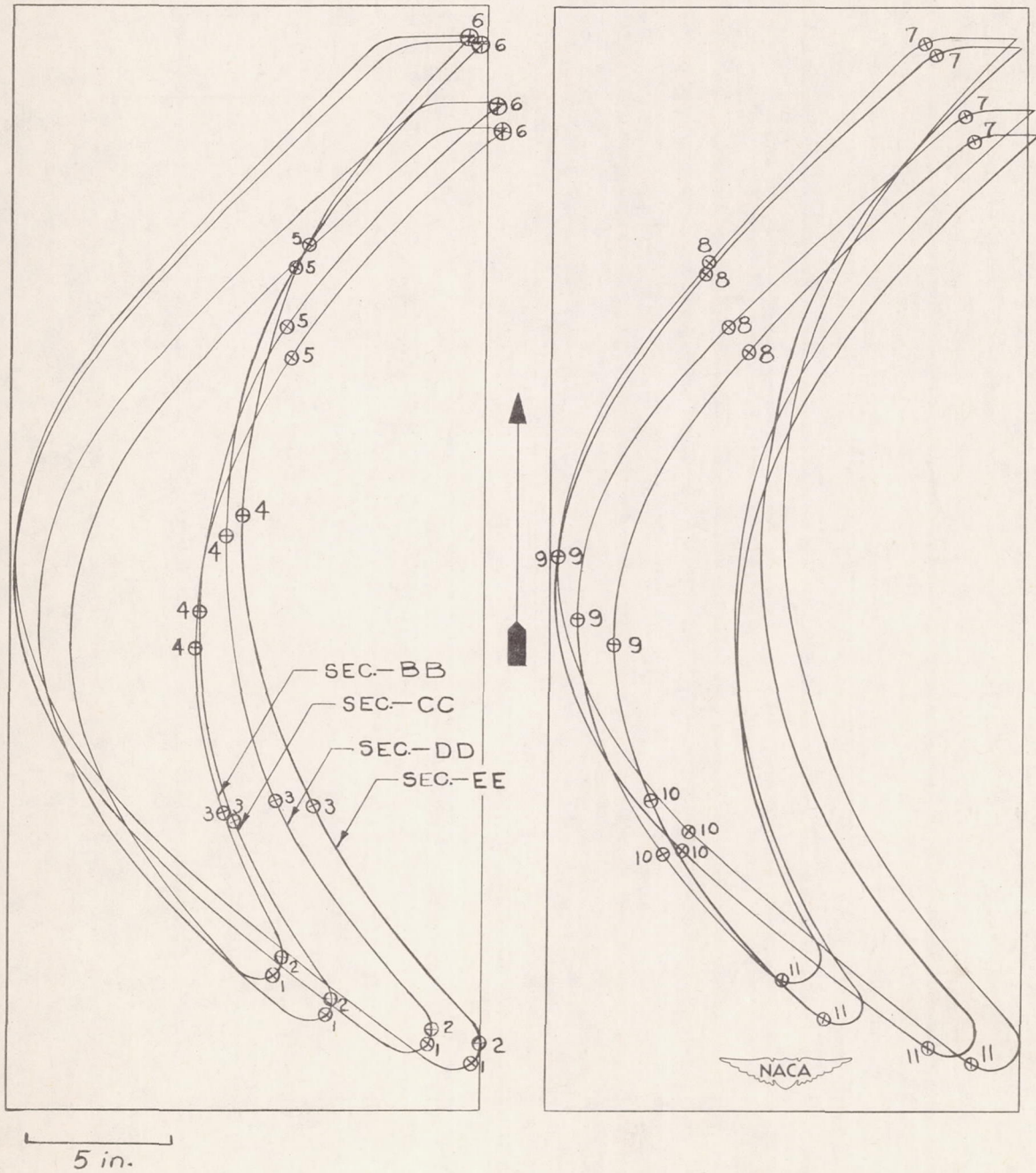


Figure 28.- Sections of rotor blade.

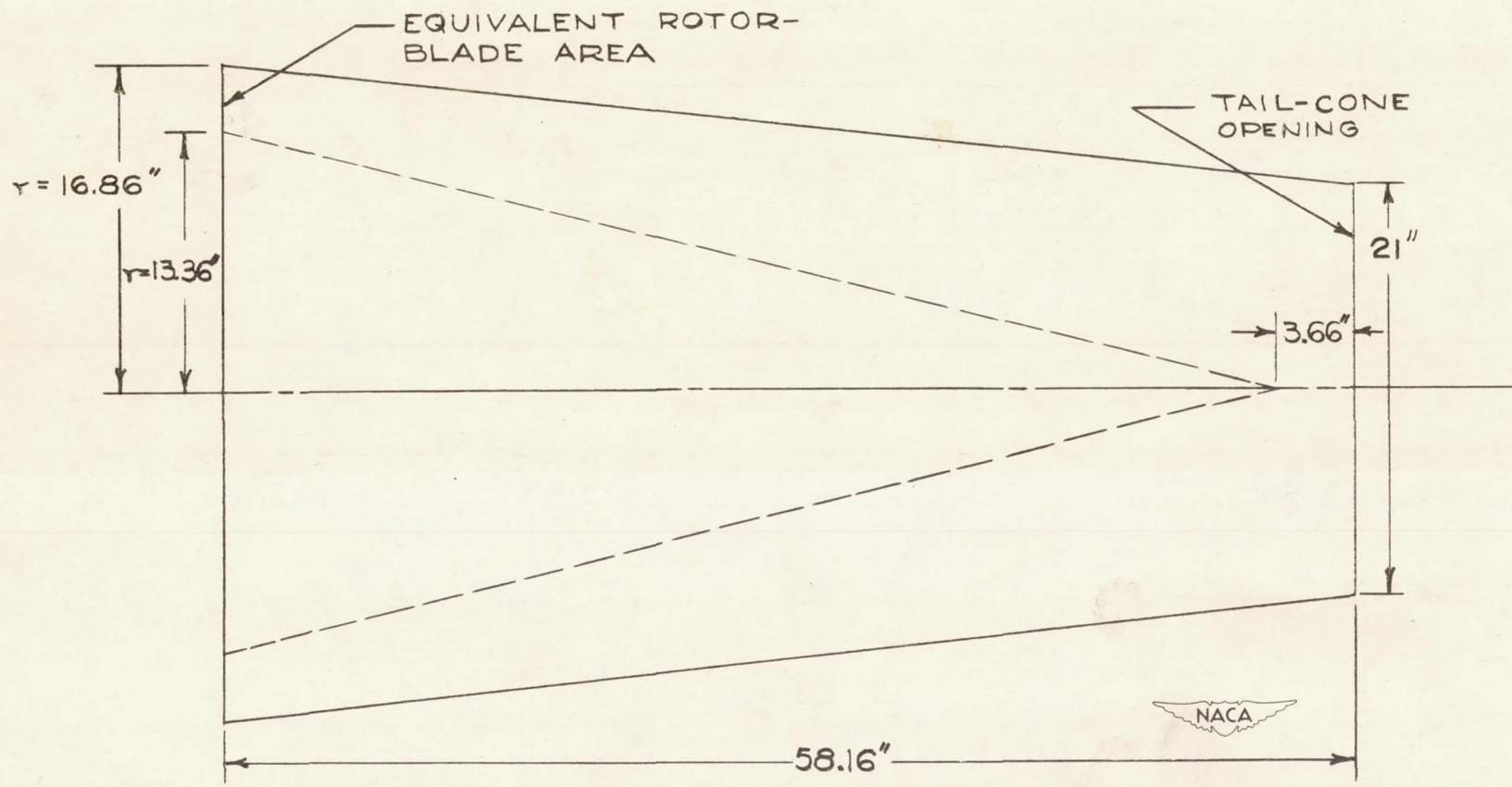


Figure 29.- Idealized geometry for tail-cone section.

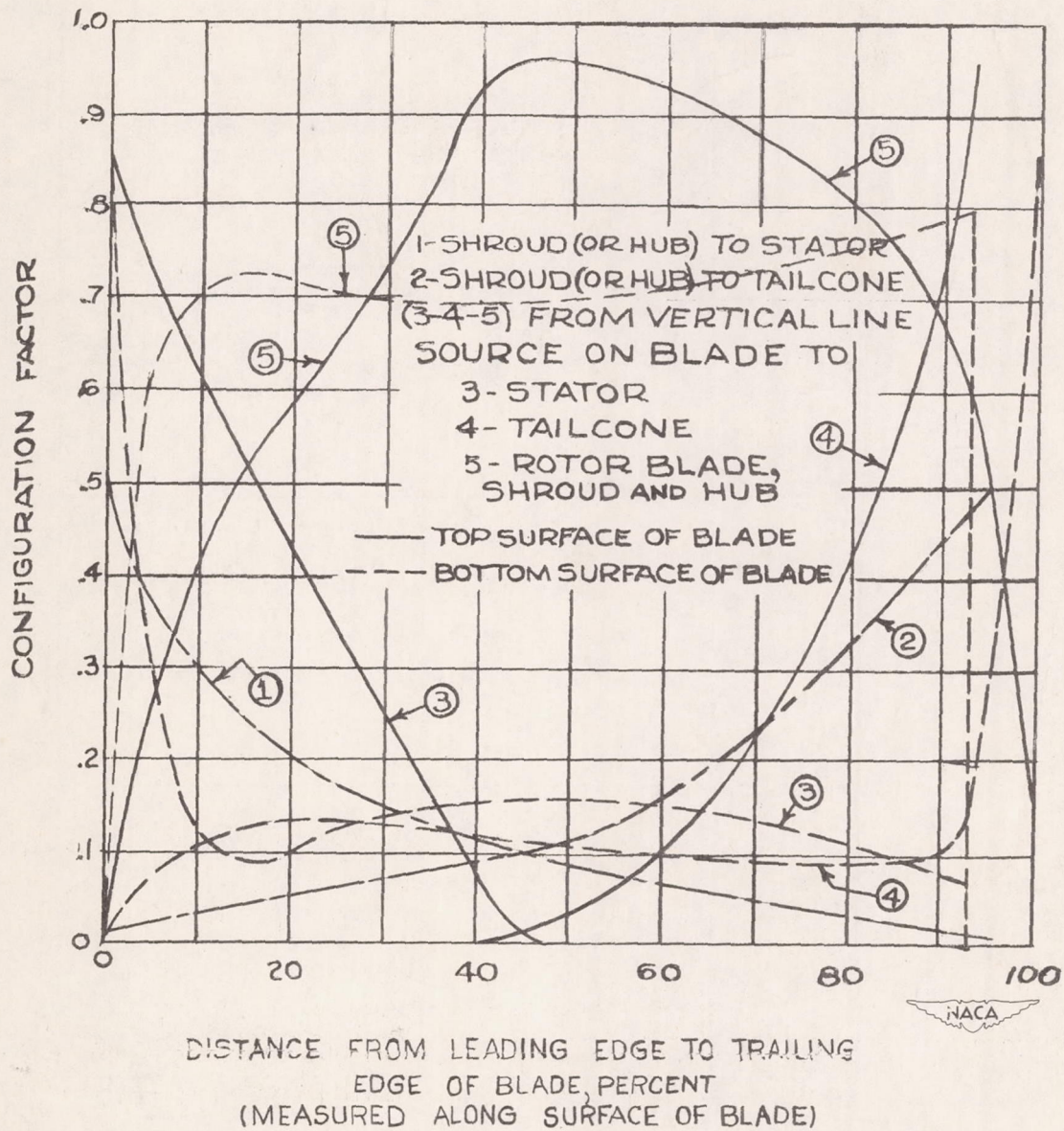


Figure 30.- Line configuration factors.

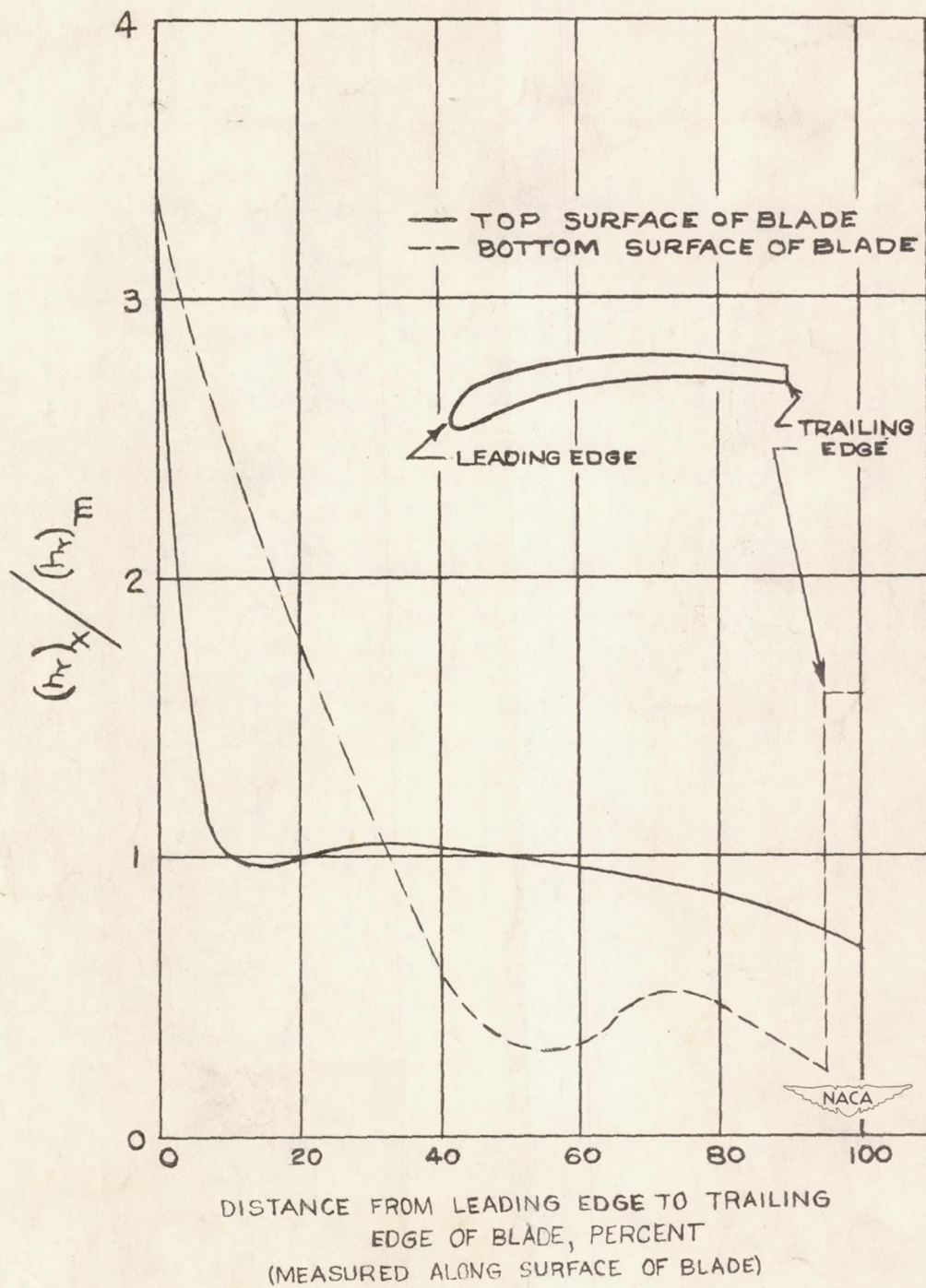


Figure 31.- Distribution of h_r over rotor-blade surface. h_r , equivalent heat-transfer coefficient due to radiation; x , local; m , mean.