

3
NACA TN 2838

TECH LIBRARY KAFB, NM
0065821

NATIONAL ADVISORY COMMITTEE FOR AERONAUTICS

TECHNICAL NOTE 2838

CALORIMETRIC DETERMINATION OF CONSTANT-PRESSURE SPECIFIC
HEATS OF CARBON DIOXIDE AT ELEVATED
PRESSURES AND TEMPERATURES

By Virgil E. Schrock
University of California



Washington
December 1952

AFMDC
TECHNICAL LIBRARY
AFL 2011



TECHNICAL NOTE 2838

CALORIMETRIC DETERMINATION OF CONSTANT-PRESSURE SPECIFIC

HEATS OF CARBON DIOXIDE AT ELEVATED

PRESSURES AND TEMPERATURES

By Virgil E. Schrock

SUMMARY

The constant-pressure specific heat of carbon dioxide has been measured over the range of pressures and temperatures from ambient conditions to 1000 pounds per square inch gage and 1000° F using a steady-flow calorimeter operating on an open cycle. It appears that the apparatus as used in this determination will yield values with a probable error of 0.5 percent at the highest temperature level considered. The results of these tests check the widely accepted spectroscopic data within 1 percent. The values at elevated pressures are in reasonable agreement with those derived from the zero-pressure spectroscopic values and the application of the Beattie-Bridgeman equation of state.

Only very limited calorimetric data are available in the literature but substantial agreement exists with those considered reliable.

INTRODUCTION

The present investigation was conducted at the University of California under the sponsorship and with the financial assistance of the National Advisory Committee for Aeronautics.

Objective and Scope of Investigation

In the present research program the use of a steady-flow calorimeter for the measurement of specific heats of gases at high temperatures and pressures has been investigated to determine the validity and limitations of the method. The purpose of this report is to present the results of tests made on carbon dioxide in the range from ambient conditions up to 1000 pounds per square inch and 1000° F. For these tests a calorimeter built of Inconel and originally designed to operate with a closed

cycle was used, but because of difficulties in metering, pumping, and regulating the flow it was elected to operate with an open cycle. Certainly a closed cycle would have some advantage in that it would allow longer runs at a single condition. It seemed advisable to make tests using the open cycle before expending any great effort in solving problems connected with the closed cycle that were not associated with the former.

Of considerable importance to the engineer are the specific heats of the constituents of the products of combustion. Because carbon dioxide is a prominent constituent in most combustion gases it was selected for these tests. Other factors influencing the selection of this gas were: (a) Its specific heat is affected to great extent by pressure, which appeared to be desirable for the purposes of the investigation, (b) it is quite inert, and (c) it is available at low cost and high purity.

Methods for Determining Specific Heats

The methods of obtaining specific heats of gases may be classified as:

- (1) Direct measurement
- (2) Determination of ratio $\gamma = c_p/c_v$
- (3) Determination of Joule-Thomson coefficients
- (4) Spectroscopic measurements

The direct measurement of the constant-volume specific heat of gases using a nonflow calorimeter is impractical because of the high capacity of the containing vessel compared with the gas contained. This was used only by very early experimenters. The measurement of the constant-pressure specific heat using a flow calorimeter can, however, be made with a high degree of precision.

The methods of determining the ratio of specific heats by the measurement of the speed of sound or the reversible adiabatic expansion method have definite shortcomings. Both require accurate pressure, volume, and temperature relations or an appropriate equation of state for the gas. Consider for example the velocity-of-sound method. Maxwell and Newton showed that the local acoustic velocity is

$$a = \sqrt{\frac{dp}{d\rho}} = \sqrt{\frac{k}{\rho}} \quad (1)$$

where k is the bulk modulus of the gas and ρ is the mass density. Laplace and Poisson suggested that the sound compression wave is isentropic, hence,

$$pv^\gamma = \text{Constant} = c$$

and

$$\begin{aligned} k &= -v \left(\frac{\partial p}{\partial v} \right)_{\text{isentropic}} \\ &= (-v) \left(\frac{-c\gamma}{v^{\gamma+1}} \right) = \gamma p \end{aligned} \quad (2)$$

then

$$a = \sqrt{\frac{\gamma p}{\rho}} \quad (3)$$

and for a perfect gas

$$a = \sqrt{\gamma gRT} \quad (4)$$

The perfect-gas law does not apply for the real gas except at zero pressure so the true equation of state must be known in order to put equation (3) in terms of the temperature. That is, p , v , and T data must be available from which ρ may be determined from measurements of pressure and temperature.

When the value of γ from the measurement of the acoustic velocity has been obtained, the specific heats may be determined from the thermodynamic identities, using the appropriate equation of state. For example,

$$c_p - c_v = T \left(\frac{\partial p}{\partial T} \right)_v \left(\frac{\partial v}{\partial T} \right)_p \quad (5)$$

and therefore

$$c_v = \frac{1}{(\gamma - 1)} T \left(\frac{\partial p}{\partial T} \right)_v \left(\frac{\partial v}{\partial T} \right)_p \quad (6)$$

Knowing the value of γ the specific heats may be determined if the derivatives can be evaluated. Note however, the value $\gamma - 1$ will be smaller than γ and therefore the value of specific heat will be less accurate than the value of γ measured. Since the specific-heat data obtained in this indirect manner require the use of an equation of state in two ways and the results are less accurate than the value of γ obtained, it is probably of less importance than the other methods.

High-pressure specific heats may be determined from Joule-Thomson measurements if the zero-pressure data are available. The pressure-temperature relationship is determined by allowing the gas to expand adiabatically without doing work and with no change in kinetic energy. Data obtained are lines of constant enthalpy on a temperature-pressure plot. The constant-pressure specific heat is given by

$$c_p = \left(\frac{\partial H}{\partial T} \right)_p$$

or for a small temperature interval

$$c_p = \left(\frac{\Delta H}{\Delta T} \right)_p$$

from which it is evident that the specific heats at various pressures are proportional to the ΔT spacing of the constant enthalpy lines and may be calculated from ΔT between the same two enthalpy lines and the known values of c_p at zero pressure.

The difficulties involved in this measurement are the maintenance of adiabatic conditions and precise measurement of the temperature. It yields the pressure effect but is not directly a measure of the specific heat. A number of authors (references 1 to 3) have used this method with success.

The values obtained spectroscopically are the zero-pressure constant-volume specific heats. Since gases obey the perfect-gas law at zero pressure the constant-pressure values can be obtained by adding the gas constant. Specific heats calculated from spectroscopic data assuming a simple oscillator are considered accurate to 0.5 percent. High-pressure specific heats may be obtained from the spectroscopic data and the thermodynamic identities as follows (reference 4):

$$\left(\frac{\partial c_v}{\partial v} \right)_T = T \left(\frac{\partial p^2}{\partial T^2} \right)_v \quad (7)$$

and

$$c_p - c_v = T \left(\frac{\partial p}{\partial T} \right)_v \left(\frac{\partial v}{\partial T} \right)_p \quad (8)$$

where again the equation of state must be known. Ellenwood, Kulik, and Gay (reference 5) have calculated the high-pressure values of specific heats for eight common gases using the spectroscopic data of Johnston (reference 6) and the Beattie-Bridgeman equation of state (reference 7).

At present the Beattie-Bridgeman equation is being used in an extrapolated form (references 5 and 8). The constants given by the authors of reference 7 were evaluated from the available data on carbon dioxide in the temperature range from -150° to 430° F. All of these data were determined in the period from 1869 to 1903 except those at less than 1 atmosphere which were obtained in 1926. The equation with the constants presented by the authors checks the data with an average deviation of 0.2 percent. The maximum deviation for carbon dioxide found in their table of comparison values was 1.3 percent which occurs near the critical point.

Use of the second derivatives of the Beattie-Bridgeman equation probably places considerable strain on its accuracy, and certainly its extrapolation to temperatures of 4000° F is somewhat questionable. Crown (reference 8) states that the chief justification of such a procedure, apart from the absence of a better one, is the good agreement existing in the range where experimental data do exist for a large number of gases even approaching the critical conditions or liquefaction. There is an obvious need for more extensive pressure, volume, and temperature data.

An abundance of empirical equations are available in the literature (references 9 to 14). These equations are based upon the spectroscopic data. Heck gives tabular thermodynamic properties, in engineering units, from the spectroscopic data (reference 15).

The direct measurement of specific heats has, in the past, been seriously limited in range because of the inability of available materials of construction to sustain high stress at high temperatures. In recent years metallurgical advances have been made to a point where sustained stresses up to about 10,000 pounds per square inch are now possible at 2000° F, making a high-temperature high-pressure calorimeter feasible. Since the only extensive specific-heat values available in the recent literature, the spectroscopic values, are essentially indirectly measured, there seems a need for confirmation by direct measurement.

SYMBOLS

c_p	specific heat at constant pressure, Btu/(lb)(°F)
\bar{c}_p	mean value of c_p , Btu/(lb)(°F)
c_v	specific heat at constant volume, Btu/(lb)(°F)
γ	specific heat ratio, c_p/c_v
R	gas constant, ft-lb/(lb)(°F)
a	speed of sound, ft/sec
k	bulk modulus, lb/sq ft
ρ	mass density, lb sec ² /ft ⁴
ρ'	weight density, lb/cu ft
g	gravitational acceleration, ft/sec ²
v	specific volume, 1/ ρ' , cu ft/lb
T	absolute temperature, °R
T_m	mean temperature, °F
p	pressure, lb/sq ft
c	constant, pv^γ
w	weight rate of flow, lb/hr
V	volumetric rate of flow, cu ft/min
Q	rate of heat addition, Btu/hr
Q_{net}	net heat added to gas
t	time, min
Δ	preceding any symbol denotes a change in that quantity
h_r	heat-transfer coefficient for radiation, Btu/(hr)(sq ft)(°F)
H	enthalpy, Btu/lb

ϵ	emissivity
M	molecular weight
Q_r	heat due to radiation, Btu/hr
F_ϵ	emissivity factor
F_a	geometric shape factor
D_1, D_2	diameters of flow tube and radiation shield, respectively, ft

DESCRIPTION OF APPARATUS AND TEST PROCEDURE

The primary components of the system used in this investigation are (fig. 1) the gas supply, the heaters to bring the temperature of the gas to the test level, the calorimeter, the aftercooler, and the meter. Schematic diagrams and sectional drawings appear in figures 1 to 4.

Calorimeter

The calorimeter consists of a shielded Inconel tube with 1-inch inside diameter housing an electrical heater and differential thermocouples which are shielded from the heater. One radiation shield, made of sheet Inconel, surrounds the test tube over its entire length, and a coil of four 3/4-inch Inconel tubes surrounds the shield. The gas enters through the coiled tubing and passes back through the test tube. This entire assembly is contained in an evacuated casing made of a 4-foot length of 8-inch Inconel tubing. The casing vacuum was produced by a Hy-Vac vacuum pump rated at 0.10 micron, thus eliminating convection within the calorimeter casing. A sectional drawing of the calorimeter is shown in figure 2. Detail of the test tube is also shown in this drawing.

Thermocouples were attached to the test tube and the calorimeter casing in order to determine steady-state conditions and estimate radiation losses. The casing of the calorimeter and tubing leading to it were wrapped with asbestos cloth. Guard heaters were wrapped as uniformly as possible on the asbestos cloth to eliminate heat loss from the calorimeter. Two layers of pipe insulation consisting of 2 inches of high-temperature and 5 inches of standard insulation were then applied.

Test Gas

Gas supply.- Commercial carbon dioxide was obtained in 50-pound cylinders from the Pure Carbonic Co. Purity of the liquefied carbon dioxide is claimed to be 99.5 percent or better. Three cylinders were manifolded together to constitute the supply reservoir. Each cylinder was wrapped with an electrical heater of 1-kilowatt capacity and insulated with asbestos cloth. Heating of the cylinders was necessary to obtain pressures above 950 pounds per square inch absolute, the vapor pressure at room temperature, and to maintain the pressure as the gas was boiled off. To be effective, the heating must be done mostly at the lower portion of the cylinder.

Control of the gas pressure in the calorimeter was accomplished by Grove pressure regulators. The lines to and from the regulator as well as its body were wrapped with a resistance heater to prevent the regulator from icing. The flow was controlled by a high-pressure stainless-steel needle valve.

Heating of gas.- In addition to the heating at the reservoir, the gas was passed through a 3-inch-diameter coil of 20 turns of heavy-wall Monel tubing. Heating was provided by a forced primary air gas burner. Close-fitting guides directed the hot flue gases over the coiled tubing. Final heating and close control of the gas test temperature were provided by a series of eight cross-wire electrical heaters having a total capacity of 4 kilowatts at 110 volts. The design was chosen so as to give the maximum heating in a minimum of space. These heaters were controlled by a variable auto transformer.

The test-gas heating in the calorimeter was provided by an electrical heater (fig. 3) of the same type as those just described.

Metering of gas.- The rate of gas flow was measured by means of a 10-cubic-foot meter prover. A water manometer connected to the inlet to the tank indicated the increase in pressure necessary to overcome the friction in the balance assembly was only 0.2 to 0.3 inch of water. This was considered negligible.

The hot gas leaving the calorimeter was cooled and humidified before being passed to the volumetric meter. Cooling was accomplished by a two-pass shell and tube heat exchanger containing ninety-six 1/4-inch-diameter brass tubes. Water surrounding the tubes was used to cool the gas flowing through the tubes.

Humidification was necessary to prevent the evaporation of the water in the volumetric tank. The gas was passed through two bottles containing ceramic-bead column packing. Only bubbles of approximately 1 centimeter

in diameter or smaller were observed, with no channeling of the flow. The gas leaving the humidifying bottles was assumed saturated with water vapor.

Applying the volumetric measurement to the determination of the weight rate of flow, the density used was obtained from reference 16 at 1 atmosphere and 32° F, this value being corrected for temperature and pressure by the perfect-gas law. The correction is quite suitable in view of the small deviation of the meter conditions from the standard. The calculation is given in appendix A.

Instrumentation

Temperature determination.- The instrumentation for temperature determination was as follows:

(a) The temperature rise used in the calculation of the specific heat was measured by differential iron-constantan thermocouples together with a White double potentiometer. Leeds & Northrup thermocouple wire and calibration slopes (fig. 5) were used. All thermocouples were checked at the melting point of pure lead and at the ice point. The maximum variation of the electromotive force of the various couples was 0.030 millivolt at the melting point, 621.6° F. To obtain the temperature difference, the difference in electromotive force was recorded with the two junctions at the same temperature (fig. 6) and again after the addition of heat. Net electromotive forces were then used to calculate the temperature differential. A Leeds & Northrup type R galvanometer was used with the White double potentiometer. This combination allowed observation of the electromotive force with a precision of 0.5 microvolt. In terms of temperature this represents approximately 0.017° F. In order to insure accurate measurements of electromotive force the Eppley standard cell, used to standardize the potentiometer current, was kept in a thermostatically controlled bath with a differential of 0.5° F.

The differential thermocouples were arranged so that the upstream thermocouple could be used to determine the temperature of the gas entering the test section. These thermocouples were mounted in double-bore ceramic insulators and centered in the test tube.

(b) Other temperature measurements were made using iron-constantan thermocouples with a Leeds & Northrup Model 8662 potentiometer. A common cold junction was used; the thermocouples were connected through a selector switch.

(c) Thermocouple leads were brought out of the high-pressure calorimeter through a seal assembly (fig. 4). Eight wires were brought through a single seal. The leads were strung through a 2-foot length of

1/4-inch-diameter stainless-steel tubing in order to get the seal away from the high-temperature region. The inner layer of glass insulation was left on the wires as they were passed through the seal. The seal was made with Sauereisen Liquid Porcelain cement.

Pressure determination.- Test-gas pressure was measured with a dead-weight gage tester. A Bourdon type pressure gage was used for visual observation of the pressure level.

Electrical heater input.- Heat added to cause a rise in temperature of the test gas was done electrically by the heater already described. The input to the heater was measured with a Weston standard wattmeter No. 326, having a precision of 1/750 of the full-scale deflection, uniform over the scale range. Accuracy is claimed by the manufacturer to be better than 0.1 percent of the full-scale reading. Supply voltage was regulated by a voltage stabilizer to eliminate variation of the heating.

Experimental Procedure

Preparation of system and preliminary tests.- As the calorimeter was assembled all parts were cleaned as well as possible using carbon tetrachloride in order to remove oil and dirt left after the machining operations. The binding material on the glass thermocouple wire insulation was removed from all leads within the calorimeter by burning it away with a small oxidizing flame. Care was taken to avoid fusing the glass insulation. This procedure left the wires insulated with clean, white, and flexible glass insulation.

All seals were pressure-tested with a soap solution prior to insulating the calorimeter. A negligible leakage could be detected from the test-gas heater lead seals but none could be detected from the thermocouple seals or any fittings on the calorimeter or downstream from it.

The system was pressurized to 1000 pounds per square inch gage and allowed to stand for 24 hours. A loss of only 50 pounds per square inch occurred during this time. This rate of leakage is negligible for the flows used and in view of tests mentioned above it appears that the major portion of this occurred upstream from the calorimeter at the electrical heaters, where the greatest difficulty in effecting a seal was encountered. Only leakage from the calorimeter and parts downstream would affect the results.

Preparation for tests.- The guard heaters were turned on and heating continued bringing the calorimeter and tubing leading to it to the desired

test temperature level and then supplying the heat loss necessary to maintain that temperature level. A period of 24 hours was allowed for this operation, on the average. Heating of the reservoir cylinders was begun about $2\frac{1}{2}$ hours before the establishment of the gas flow and was continued until a pressure of 1800 to 2000 pounds per square inch gage was reached. Heat was then supplied to maintain the reservoir pressure after establishment of flow.

Tests.- When the temperature level and reservoir pressure were at the desired conditions the gas flow was established at a pressure of 1000 pounds per square inch gage in the calorimeter. Heating was adjusted until the gas entered the test section at the temperature of the calorimeter. After observing the reading of the differential thermocouple for isothermal conditions at that temperature level the test-gas heating was started and adjusted to produce a temperature rise of the gas of 20° to 35° F.

Data were recorded until the conditions remained unchanged for a period of about 20 minutes; thus a value of specific heat was obtained at a particular temperature and at 1000 pounds per square inch gage. The pressure was then reduced but the weight rate of flow maintained constant. Following this procedure the steady-state conditions were affected only by the influence of pressure upon the specific heat and a new steady-state condition could be reached much more rapidly than the first. In this way a series of measurements was made at each temperature level and various pressures. In most cases data were obtained at four pressure levels at each temperature.

DISCUSSION

Validity of Results

Specific heats obtained herein are mean values for a temperature range of 20° to 35° F and were obtained from

$$\bar{c}_p = \frac{Q_{\text{net}}}{W\Delta T}$$

The net heat added was obtained from the wattage supplied and the calculated heat loss from the test section. In two cases the loss included a small correction due to a slight transient condition. It has been pointed out that the velocity of sound and spectroscopic methods have the advantage of yielding instantaneous values, whereas the flow

calorimeter gives a mean over a temperature range. The values obtained in this investigation are reported at the arithmetic mean temperature, which is equivalent to assuming that the specific heat is a linear function of the temperature in that range. The rate of change of the specific heat with temperature over a 20° to 35° F range is sufficiently constant so that no serious error will result from this assumption.

An analysis of error (appendix B) indicates a maximum error of 0.42 percent and a probable error of 0.25 percent. In view of other uncertainties such as the accuracy of the correction applied to heat input the results are considered accurate to only 0.5 percent. The maximum correction applied was 4.3 percent and was at the maximum temperature, 950° F. At the 685° F level the correction was only 2.0 percent. Because of the dependence of radiation upon the fourth power of the absolute temperature the heat-loss uncertainty would become significant above 1000° F. Additional shielding, the use of a higher flow rate, and a lower temperature differential should allow accurate measurements up to 2000° F.

Presentation of Results

The experimental values of the specific heats are plotted in figures 7 to 12 as a function of pressure at each temperature level employed during the tests. In each case the data have been shown in comparison with those of Ellenwood, Kulik, and Gay since their data are the most extensive and probably the most reliable to date. Other low-pressure data (references 17 and 18) are in agreement with those of Johnston et alii (reference 6).

Figures 13 to 18 show the specific heats as a function of temperature for constant pressures and were obtained by interpolation between points and extrapolation to zero pressure. Points were shown on the curves of experimental data in order to indicate the magnitude of the deviation from the mean lines. Experimental curves from figures 13 to 17 have been plotted together in figure 18 to show the effects of temperature and pressure simultaneously. The results are tabulated in table I.

A comparison of the experimental results with data of Goodenough and Felbeck (reference 19), Partington and Schilling (reference 20), and Johnston (reference 6) is shown in figure 19. These data are for low pressure. The effect of a pressure of 1 atmosphere in this temperature range is very small. Two points, the data of Swann (reference 21) at 1 atmosphere, were included in this comparison because they represent accurate calorimetric measurements and are in good agreement with the results of these tests, especially in trend.

The data of Partington and Schilling represent the average of a large collection of data obtained by various methods, the majority being from velocity-of-sound measurements. No comparisons of the earlier high-pressure measurements have been included since those data were few and inconsistent, showing only qualitatively the effect of pressure.

Limitations of Calorimeter

Factors involved in the optimum calorimeter design conditions are:

- (1) Limitation of temperature rise to allow accurate representation of the data by mean values, but large enough to allow accurate measurement
- (2) Limitation of the flow velocity to eliminate recovery in temperature measurements
- (3) A high ratio of gas capacity to container capacity
- (4) A large heat input compared with the losses

Unfortunately these factors oppose one another, requiring a compromise condition. It has already been pointed out that the temperature differential used was 20° to 35° F and that this satisfies the first condition. This was considered to be an independent requirement and the other conditions selected on this basis.

The flow velocity during these tests varied with pressure and temperature since the weight rate of flow was maintained constant, for the reasons previously stated. The maximum velocity obviously occurred at the maximum temperature and minimum pressure. Approximate calculations, based on the assumption of a perfect gas, indicate that the maximum Mach number was 0.026 which corresponds to a stagnation temperature rise of only 0.01° F.

The third condition is necessary to minimize the effect of transient conditions. A high weight rate of flow and as thin a tube as possible are desired. Condition (4) also requires a high weight rate of flow and minimization of the heat losses. Both these conditions were met satisfactorily. However, for an extended temperature range a higher flow rate and additional shielding seem advisable. It appears that a practical limit of the temperature range will be dictated by the radiation loss because of its rapid increase with temperature.

CONCLUSIONS

The following conclusions were drawn from an investigation of the calorimetric determination of the constant-pressure specific heats of carbon dioxide at elevated pressures and temperatures:

1. The results are a reasonable confirmation of the specific-heat values of carbon dioxide obtained spectroscopically for the zero-pressure state and over the range of temperatures from 100° to 700° F. The experimental data are approximately 1 percent lower than the spectroscopic data. This small difference may be due to lack of complete equilibrium; that is, the vibrational energy may not be fully activated at the point where the temperature rise is observed.

2. Greater difference exists between the high-pressure values measured and those computed by Ellenwood, Kulik, and Gay. The maximum deviation is approximately 3 percent and occurs at a pressure of 1000 pounds per square inch absolute and 500° F. The agreement is much closer at this pressure for both higher and lower temperatures. This deviation may be explained by the stress placed on the Beattie-Bridgeman equation in obtaining the second derivatives.

3. A single measurement at 950° F and 1000 pounds per square inch gage seems to offer confirmation of the spectroscopic data at this higher temperature level.

4. The results show that the effect of pressure upon the specific heat becomes less significant at higher temperatures, as predicted by the thermodynamic identities and the Beattie-Bridgeman equation of state.

5. The equipment should be modified to reduce the radiation loss further when used at higher temperatures.

University of California
Berkeley, Calif., January 31, 1952

APPENDIX A

CALCULATIONS

The specific heats were determined from:

$$c_p = \left(\frac{\partial H}{\partial T} \right)_p = \left(\frac{\Delta H}{\Delta T} \right)_p = \frac{Q_{net}}{w \Delta T}$$

Flow Rate

Since the flow rate was metered volumetrically an accurate density determination was necessary. It was determined from the value given in reference 16 at 0° C and 1 atmosphere as follows:

$$\text{Density} = 1.9769 \text{ grams/liter}$$

$$1 \text{ gram} = 0.002205 \text{ lb}$$

$$1 \text{ liter} = 0.03531 \text{ cu ft}$$

from which

$$\rho' = 1.9769 \times \frac{0.002205}{0.03531} = 0.1235 \text{ lb/cu ft}$$

and

$$R = \frac{p}{\rho' T} = \frac{14.696 \times 144}{0.1235 \times 491.6} = 34.88 \text{ ft-lb}/(\text{lb})(^\circ\text{F})$$

This is not the true gas constant 1544/M (where M is the molecular weight), but its use near the standard conditions will yield more-accurate results than

$$R = 1544/M = 35.11$$

The use of the value 34.88 foot-pounds per foot per °F is justified by the small deviation of the meter conditions from the standard. The saturation pressure of the water vapor was subtracted from the barometric to obtain the partial pressure of the carbon dioxide at the meter.

Temperature Rise

Readings of the electromotive force of the differential thermocouples were corrected by subtracting the electromotive force observed with the two junctions at the same temperature. A curve of the isothermal differential is given in figure 6. The net differential was converted to temperature by using the Leeds & Northrup calibration slopes (for standard 11031 thermocouples) given in figure 5.

Net Heat Addition

The net heat added to the gas was found by correcting for the heat losses as follows:

(a) Measurement of wall temperatures indicates that no net heat loss occurred because of conduction along the test section. Apparently heat was conducted back into the downstream end at the same rate it left the upstream end, within the accuracy of experimental measurements.

(b) The radiation loss was calculated from the Stefan-Boltzmann law as follows:

$$Q_r = 0.173F_\epsilon F_a \left[\left(\frac{T_1}{100} \right)^4 - \left(\frac{T_2}{100} \right)^4 \right]$$

where the subscript r refers to radiation, F_ϵ is the emissivity factor, and F_a is the geometric shape factor. This can be written in the form

$$Q_r = F_\epsilon F_a h_r (T_1 - T_2)$$

where h_r is the heat-transfer coefficient for radiation and is a function of the temperature level and the difference $T_1 - T_2$. The shape factor $F_a = 1$. The emissivity factor for this geometry is given by

$$F_\epsilon = \frac{1}{\frac{1}{\epsilon_1} + \left(\frac{D_1}{D_2} \right)^2 \left(\frac{1}{\epsilon_2} - 1 \right)}$$

in which ϵ is the emissivity and D_1 and D_2 are the diameters of the flow tube and the radiation shield, respectively.

The emissivity was obtained from spectral measurements made on an equivalent nickel-chrome alloy (fig. 20). Total emissivities were obtained by graphical integration of the curves of Plankian radiation and actual emission at various temperatures. The results indicate a linear variation of total emissivity with temperature (fig. 21).

The use of the linear relationship for radiation simplifies the shield calculation; that is,

$$F_{\epsilon_{1-2}} = \frac{1}{\frac{1}{\epsilon_1} + \left(\frac{D}{D_2}\right)^2 \left(\frac{1}{\epsilon_2} - 1\right)}$$

$$F_{\epsilon_{2-3}} = \frac{1}{\frac{1}{\epsilon_2} + \left(\frac{D}{D_3}\right)^2 \left(\frac{1}{\epsilon_3} - 1\right)}$$

then

$$\frac{Q_r}{h_r \Delta T} = \frac{1}{\frac{1}{\frac{1}{\epsilon_1} + \left(\frac{D}{D_2}\right)^2 \left(\frac{1}{\epsilon_2} - 1\right)} + \frac{1}{\frac{1}{\epsilon_2} + \left(\frac{D_2}{D_3}\right)^2 \left(\frac{1}{\epsilon_3} - 1\right)}}$$

the results of this calculation are given in figure 22.

Values of h_r were computed at various temperatures using the mean temperature difference (table II) and these values used to compute the radiation loss from the test section per hour per degree mean temperature difference (fig. 23).

(c) Using heat capacity and density data furnished by the International Nickel Co., producers of Inconel, the capacity of the test section was determined and a correction applied because of a slight transient condition during two of the runs. This correction was 2.8 percent of the heat added for run 1 and 1.0 percent for run 5.

APPENDIX B

ANALYSIS OF ERROR OF OBSERVATION

The errors of observation in run 16, which is used as an example, where

$$c_p = \frac{Q}{w \Delta T} = \frac{229.3}{30.19 \times 33.55} = 0.2263 \text{ Btu/(lb)(}^\circ\text{F)}$$

are given below.

Error in Q ($Q = 229.3$ Btu/hr read to $\pm 1/4$ watt with scale factor $1/4$):

$$\pm \frac{1}{4} \times \frac{1}{4} \times 3.413 = \pm 0.21 \text{ Btu/hr}$$

$$\pm \frac{0.21}{229.3} = \pm 0.091 \text{ percent}$$

Error in ΔT ($\Delta T = \text{Potentiometer indication/Calibration slope}$):

$$\text{Potentiometer indication} = 1.2065 \pm 0.0005 \text{ mv}$$

$$\text{Calibration slope} = 0.03060 \pm 0.00005 \text{ mv}/^\circ\text{F}$$

$$\Delta T = 33.55^\circ \text{ F}$$

Error due to potentiometer tolerance:

$$\frac{0.0005}{1.2065} = 0.00041$$

Error due to slope tolerance:

$$\frac{0.00005}{0.03060} = 0.0016$$

Maximum error:

$$\Delta(\Delta T) = \sqrt{33.44(0.0016 + 0.00041)} = \pm 0.067$$

$$T = 33.55 \pm 0.067^{\circ} \text{ F}$$

Probable error:

$$\Delta(\Delta T) = \sqrt{(33.44 \times 0.0016)^2 + (33.55 \times 0.00041)^2} = \pm 0.0555$$

$$\Delta T = 33.55 \pm 0.056^{\circ} \text{ F}$$

$$\text{Error in } w \left(w = \frac{60\rho'V}{t} = 30.19 \text{ lb/hr} \right)$$

$$\rho' = \frac{p}{RT}$$

No error resulted from p or R.

$$\Delta\rho' = \rho' \frac{\Delta T}{T} = 0.1089 \times \frac{0.25}{530} = 0.000051$$

$$V = 9.82 \pm 0.0025 \text{ cu ft}$$

$$t = 2.126 \pm 0.002 \text{ min}$$

Maximum error in w:

$$\begin{aligned} \Delta w &= w \left(\frac{\Delta\rho'}{\rho'} + \frac{\Delta V}{V} + \frac{\Delta t}{t} \right) \\ &= 30.19 \left(\frac{0.000051}{0.1089} + \frac{0.0025}{9.18} + \frac{0.002}{2.216} \right) = 0.05 \end{aligned}$$

$$w = 30.19 \pm 0.05$$

Probable error in w :

$$\Delta w = \sqrt{(30.19 \times 0.0047)^2 + (30.19 \times 0.00025)^2 + (30.19 \times 0.00094)^2}$$

$$w = 30.19 \pm 0.032$$

Maximum error in c_p :

$$\begin{aligned} \Delta c_p &= c_p \left[\frac{\Delta w}{w} + \frac{\Delta(\Delta T)}{\Delta T} + \frac{\Delta Q}{Q} \right] \\ &= 0.2263 \left(\frac{0.05}{30.19} + \frac{0.056}{33.55} + \frac{0.21}{229.3} \right) = 0.00095 \end{aligned}$$

$$c_p = 0.2263 \pm 0.00095 \text{ Btu/lb/}^\circ\text{F} \text{ or } \pm 0.42 \text{ percent}$$

Probable error in c_p :

$$\Delta c_p = c_p \sqrt{\left(\frac{\Delta w}{w} \right)^2 + \left[\frac{\Delta(\Delta T)}{\Delta T} \right]^2 + \left(\frac{\Delta Q}{Q} \right)^2}$$

$$\frac{\Delta c_p}{c_p} = \sqrt{0.00165^2 + 0.00165^2 + 0.00091^2} = \pm 0.0025 \text{ or } \pm 0.25 \text{ percent}$$

Customarily it is felt that the probable error as calculated here is more applicable, but in view of other uncertainties such as calculation of radiant losses and possibility of a slight transient condition a more pessimistic view should be taken. The results are believed to be accurate to 0.5 percent.

REFERENCES

1. Keenan, J. H.: Progress Report on the Development of Steam Charts and Tables from the Harvard Throttling Experiments. Mech. Eng., vol. 48, no. 2, Feb. 26, 1926, pp. 144-151.
2. Roebuck, J. R.: The Joule-Thomson Effect in Air. Proc. Am. Acad. Arts and Sci., vol. 60, no. 13, Dec. 1925, pp. 537-596; vol. 64, no. 9, Aug. 1930, pp. 287-334.
3. Sage, B. H., Kennedy, E. R., and Lacy, W. N.: Phase Equilibria in Hydrocarbon Systems. Ind. and Eng. Chem., vol. 28, no. 5, May 1936, pp. 601-604.
4. Dodge, Barnett Fred: Chemical Engineering Thermodynamics. First ed., McGraw-Hill Book Co., Inc., 1944.
5. Ellenwood, Frank O., Kulik, Nicholas, and Gay, Norman R.: The Specific Heats of Certain Gases over Wide Ranges of Pressures and Temperatures. Air, CO, CO₂, CH₄, C₂H₂, H₂, N₂, and O₂. Bull. No. 30, Eng. Exp. Station, Cornell Univ., Oct. 1942.
6. Johnston, H. L., Davis, C. O., Chapman, A. T., Walker, M. K., and Dawson, D. H.: Heat Capacity Curves of the Simpler Gases. Jour. Am. Chem. Soc., ser. A, vol. 55, no. 1, Jan. 1933, pp. 153-186; no. 7, July 1933, pp. 2744-2753; vol. 56, no. 2, Feb. 1934, pp. 271-276; vol. 57, no. 4, April 1935, pp. 682-684.
7. Beattie, J. A., and Bridgeman, O. C.: A New Equation of State. Proc. Am. Acad. Arts and Sci., vol. 63, no. 5, Dec. 1928, pp. 229-308.
8. Crown, J. C.: Flow of a Gas Characterized by the Beattie-Bridgeman Equation of State and Variable Specific Heats. Memo. No. 9619, Naval Ord. Lab., April 1949.
9. Bryant, W. M. D.: Empirical Molecular Heat Equations from Spectroscopic Data. Ind. and Eng. Chem., vol 25, no. 7, July 1933, pp. 820-823.
10. Chipman, J., and Fontana, M. G.: A New Approximate Equation for Heat Capacity at High Temperatures. Jour. Am. Chem. Soc., vol. 57, no. 1, Jan. 1935, pp. 48-51.

11. Eastman, E. D.: Specific Heats of Gases at High Temperatures. Tech. Paper 445, Bur. Mines, Dept. Commerce, 1929.
12. Spencer, H. M., and Justice, J. L.: Empirical Heat Capacity Equations for Simpler Gases. Jour. Am. Chem. Soc., vol. 56, no. 11, Nov. 1934, pp. 2311-2312.
13. Smallwood, J. C.: Equations for the Specific Heats of Gases. Ind. and Eng. Chem., vol. 34, no. 7, July 1942, pp. 863-864.
14. Sweigert, R. L., and Beardsley, M. W.: Empirical Specific Heat Equations Based upon Spectroscopic Data. Bull. No. 2, Eng. Exp. Station, Ga. School of Tech., vol. 1, no. 8, June 1938.
15. Heck, R. C. H.: The New Specific Heats. Mech. Eng., vol. 62, no. 1, Jan. 1940, pp. 9-12.
16. Washburn, Edward W. (ed.): International Critical Tables. Vol. III. McGraw-Hill Book Co., Inc., 1928, p. 3.
17. Kassel, L. S.: Thermodynamic Functions of Nitrous Oxide and Carbon Dioxide. Jour. Am. Chem. Soc., vol. 56, no. 9, Sept. 1934, pp. 1838-1842.
18. Woolley, Harold W.: Carbon Dioxide (Ideal Gas State). NBS-NACA Tables of Thermal Properties of Gases, Table 13.10, July 1950.
19. Goodenough, G. A., and Felbeck, G. T.: An Investigation of the Maximum Temperatures and Pressures Attainable in the Combustion of Gaseous and Liquid Fuels. Bull. No. 139, Eng. Exp. Station, Univ. of Ill., March 17, 1924.
20. Partington, J. R., and Schilling, W. G.: The Specific Heats of Gases. Ernest Benn (London), 1924.
21. Swann, W. F. G.: Specific Heats of Air and CO₂ at One Atmosphere, by a Continuous Electrical Method. Proc. Roy. Soc. (London), ser. A, vol. 82, no. 553, May 6, 1909, pp. 147-149.
22. Henry, P. S. H., Blackett, P. M. S., and Rideal, E. K.: A Flow Method for Comparing the Specific Heats of Gases. Proc. Roy. Soc. (London), ser. A, vol. 126, no. 801, Jan. 1, 1930, pp. 319-333.
23. Osborne, Nathan S., Stimson, H. F., and Slight, T. S., Jr.: A Flow Calorimeter for Specific Heats of Gases. Sci. Paper No. 503, Bur. Standards, vol. 20, April 4, 1925, pp. 498-523.

TABLE I
TABULATED RESULTS

Run	Flow rate (lb/hr)	Net heat input (Btu/hr)	Temperature rise (°F)	Mean temperature (°F)	Pressure (psia)	C_p (Btu/(lb)(°F))
^a 1	30.71	174.2	21.23	339.0	1015	0.2669
2	31.54	252.5	31.57	338.0	715	.2537
3	34.78	217.4	25.68	339.0	415	.2435
4	31.45	200.7	27.83	339.0	20	.2293
^a 5	28.75	213.2	28.50	540.5	1015	.2612
6	28.13	208.2	28.82	537.5	715	.2569
7	31.21	208.4	26.40	535.5	415	.2531
8	33.40	207.5	25.08	533.5	20	.2475
9	30.42	425.9	38.10	145.0	1015	.3672
10	29.10	286.7	34.32	101.5	515	.2870
11	32.71	283.3	36.82	99.5	315	.2371
12	37.58	264.1	34.50	99.5	20	.2038
13	28.10	259.9	34.40	297.0	1015	.2687
14	32.67	234.5	28.40	292.0	715	.2530
15	30.38	234.0	31.82	293.0	415	.2420
16	30.19	229.3	33.55	293.0	20	.2263
17	28.08	234.8	32.12	456.0	1015	.2605
18	29.93	234.2	30.62	453.0	715	.2555
19	28.92	233.1	32.05	453.0	415	.2514
20	30.12	232.2	31.40	454.0	215	.2457
21	32.78	251.8	31.52	455	20	.2435
22	31.10	264.7	31.20	680	1015	.2727
23	30.00	263.5	32.63	685	715	.2691
24	30.42	279.2	34.78	686	415	.2683
25	30.68	279.1	35.10	687	20	.2589
26	30.23	282.0	32.70	951	1015	.2853

^aCorrected for a slight transient condition. (See appendix A.)



TABLE II

VALUES COMPUTED USING MEAN TEMPERATURE DIFFERENCE

Temperature (°F)	h_r	$\frac{Q_r}{h_r \Delta T}$	$\frac{Q_r}{\Delta T}$
100	1.40	0.0186	0.0260
200	2.00	.0210	.0420
400	4.40	.0260	.1144
600	8.20	.0310	.2540
800	14.0	.0360	.4890
1000	22.0	.0410	.9020



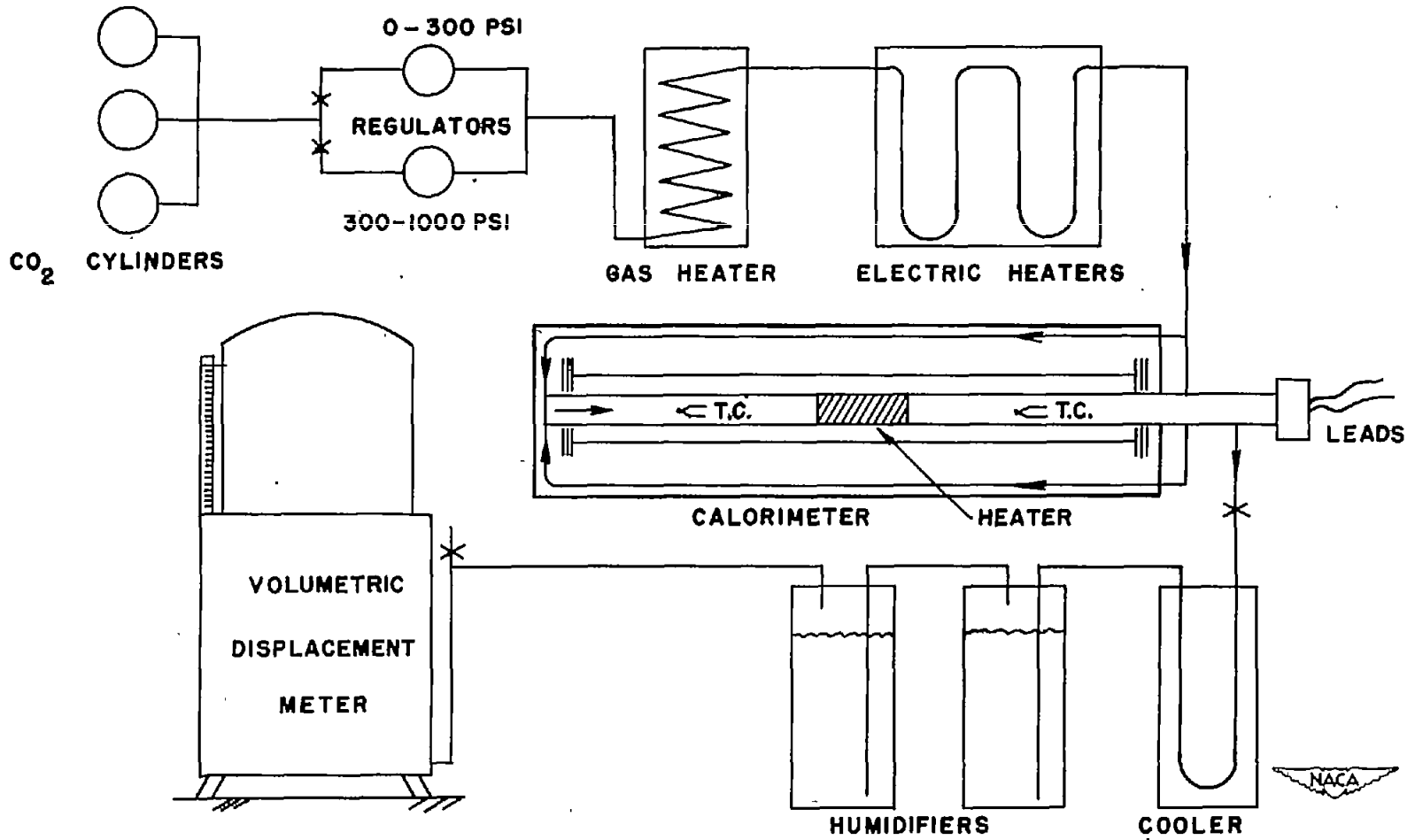

Figure 1.- Schematic layout of system.

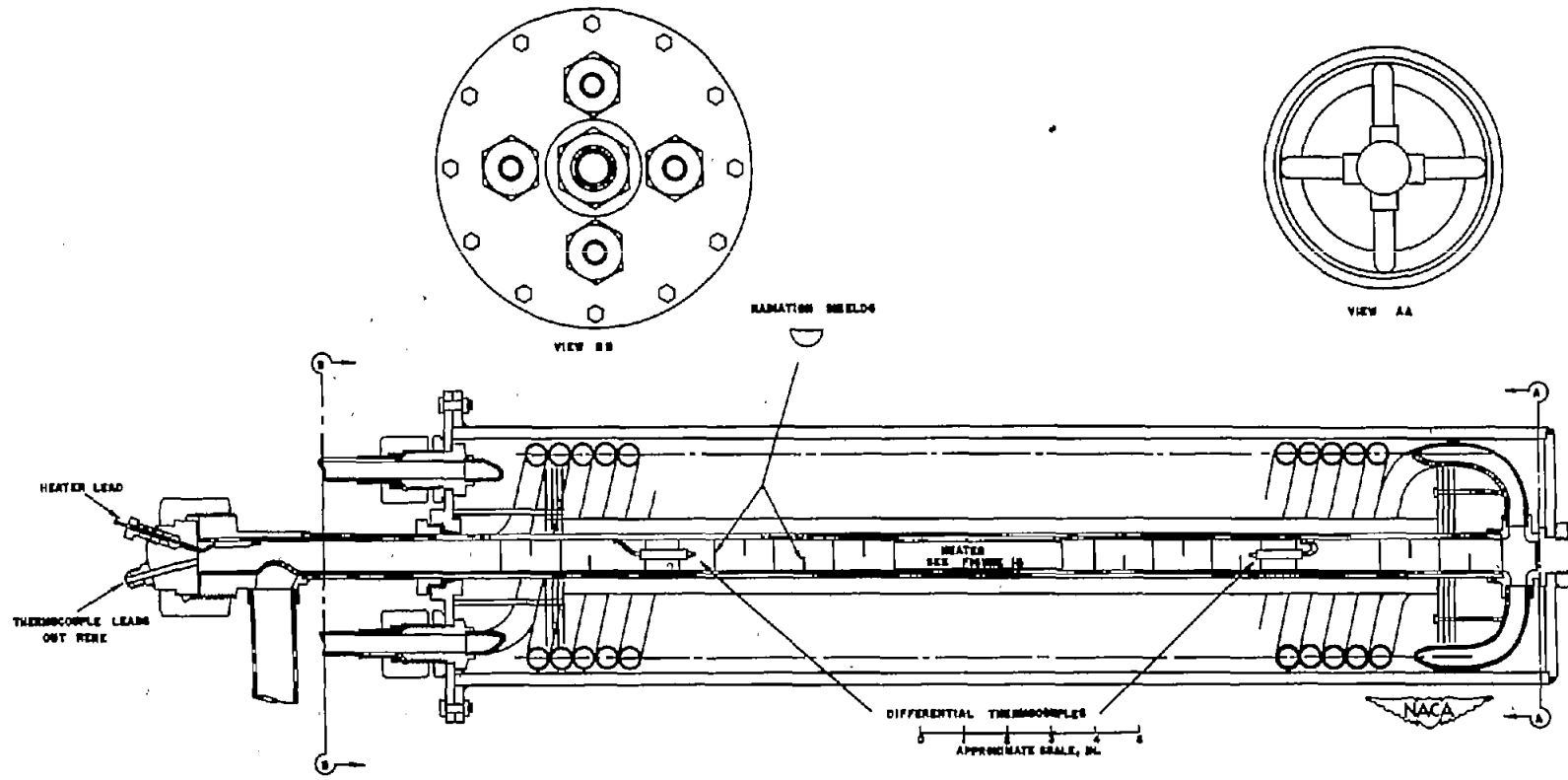
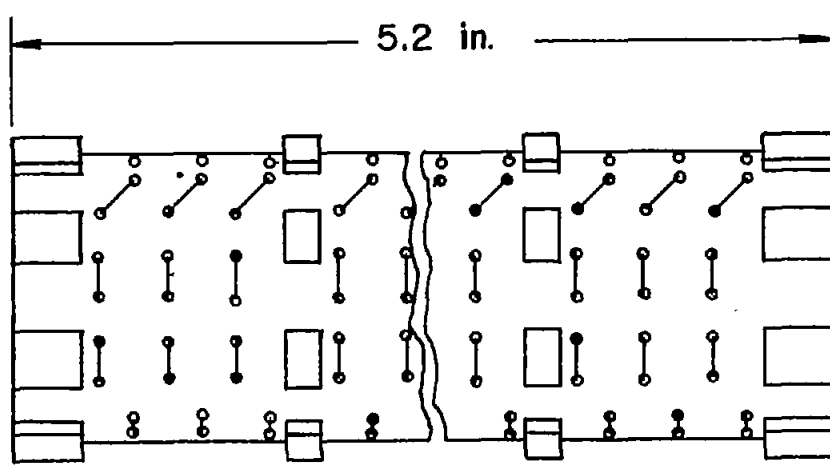

Figure 2.- Calorimeter detail.



Heater Wound With 14.3 ft of
No.26 Kanthal Wire

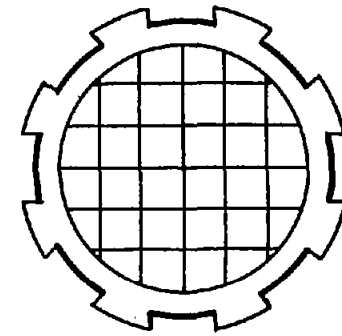

Figure 3.- Test-gas electrical heater. Twice full scale.

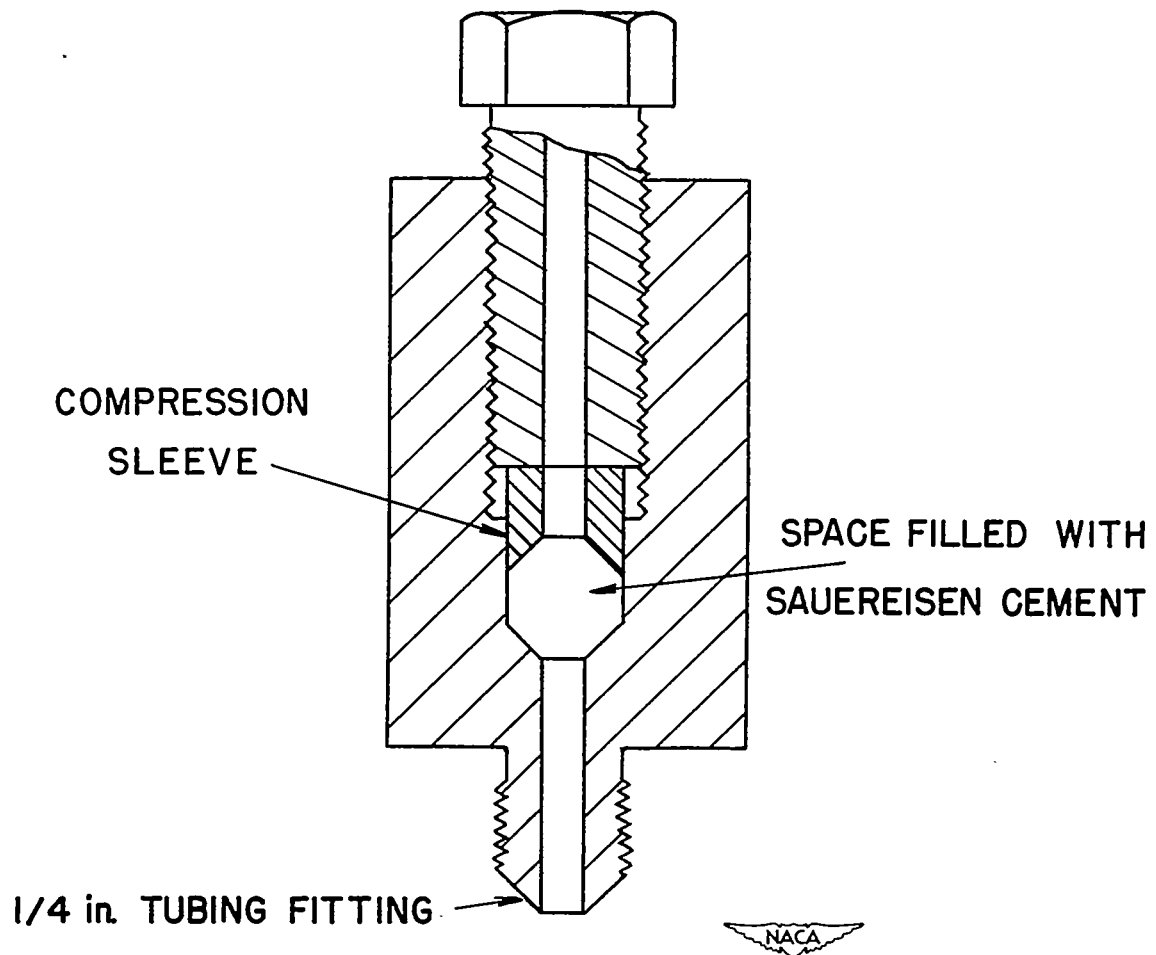

Figure 4.- Thermocouple lead seal assembly. Twice full scale.

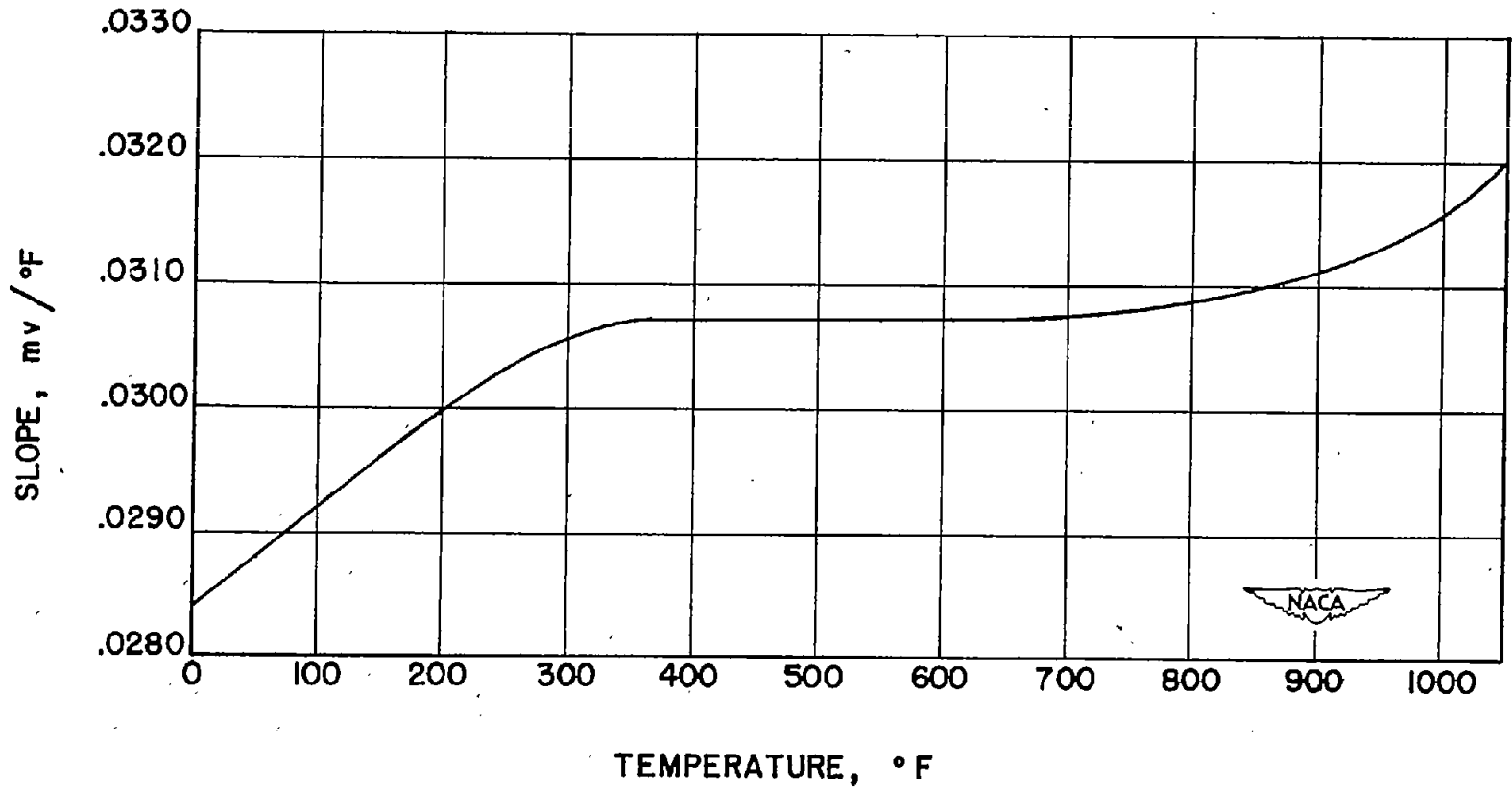

Figure 5.- Slope of calibration curve for Leeds & Northrup standard 11031 iron-constantan thermocouple.

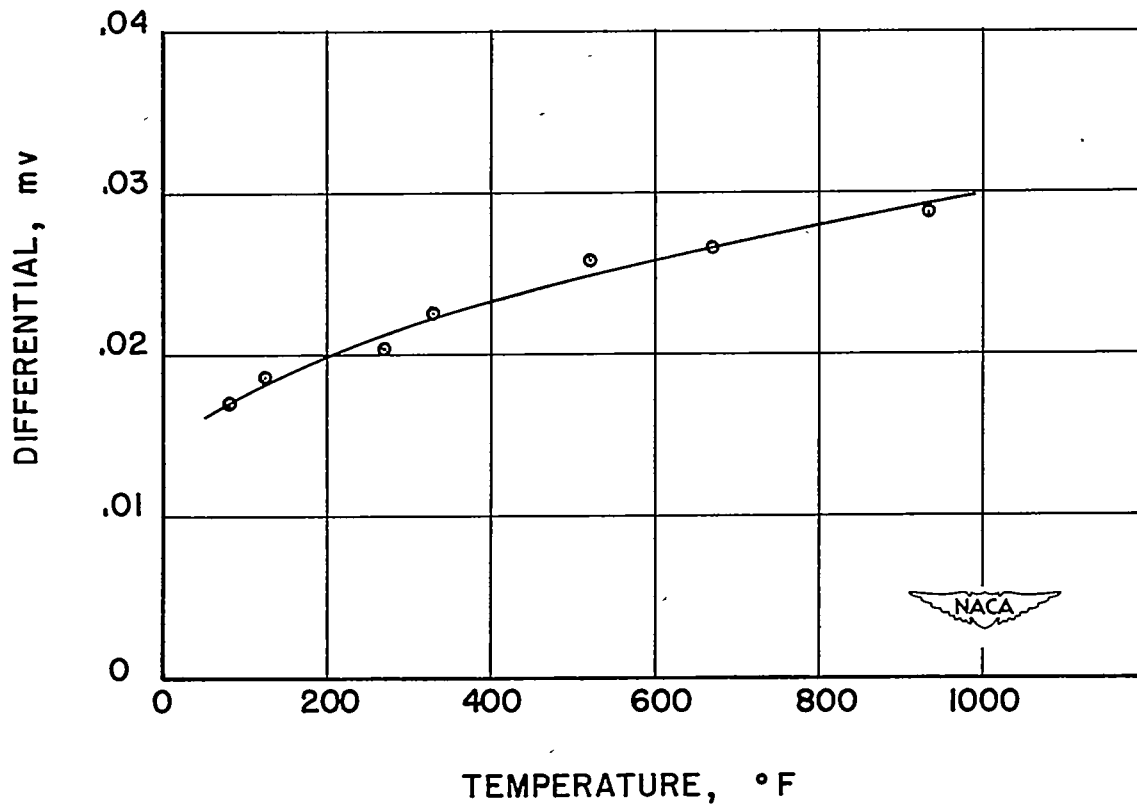

Figure 6.- Isothermal differential for differential thermocouple.

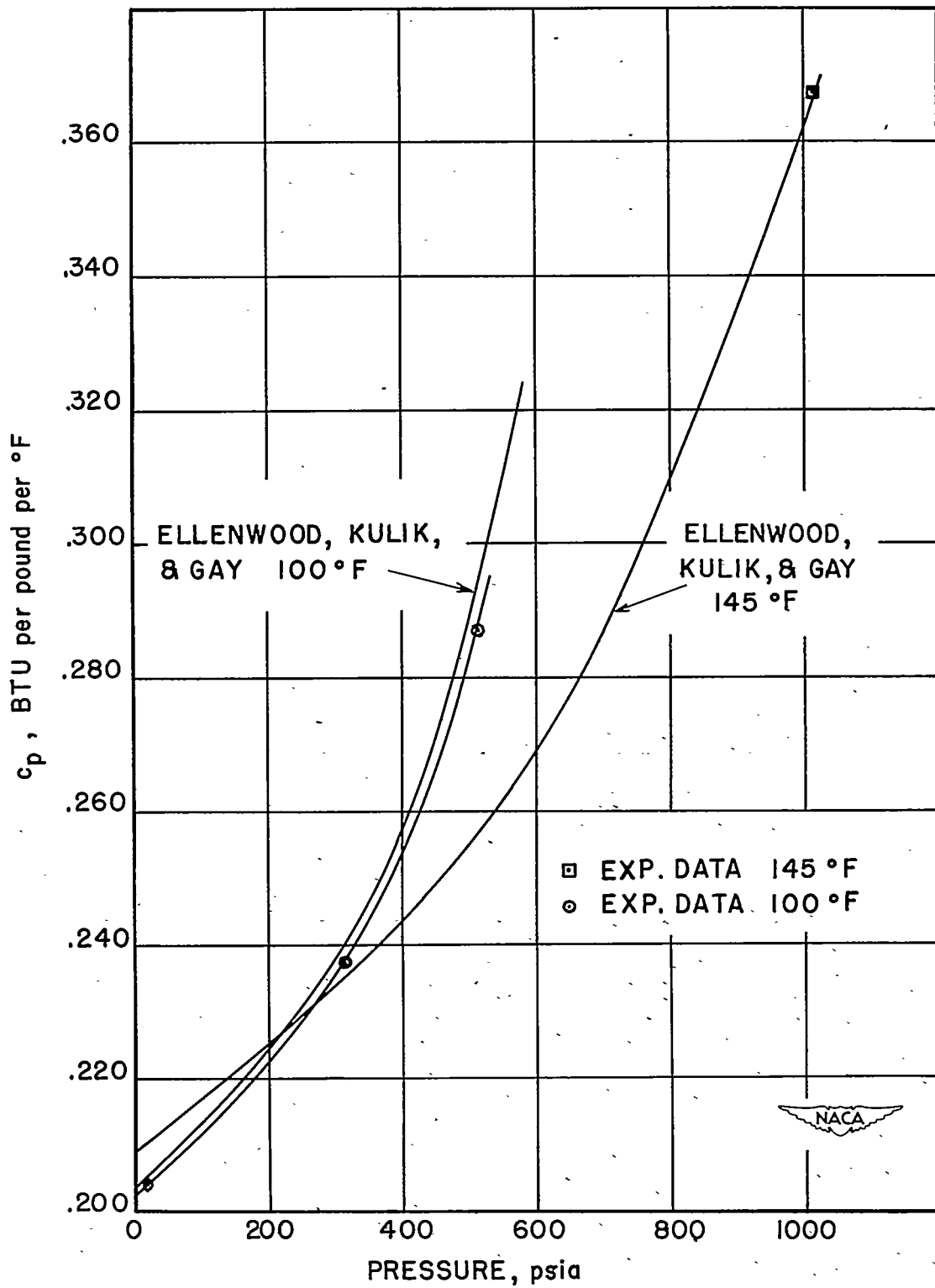

Figure 7.- Effect of pressure upon constant-pressure specific heat of carbon dioxide at 100° and 140° F.

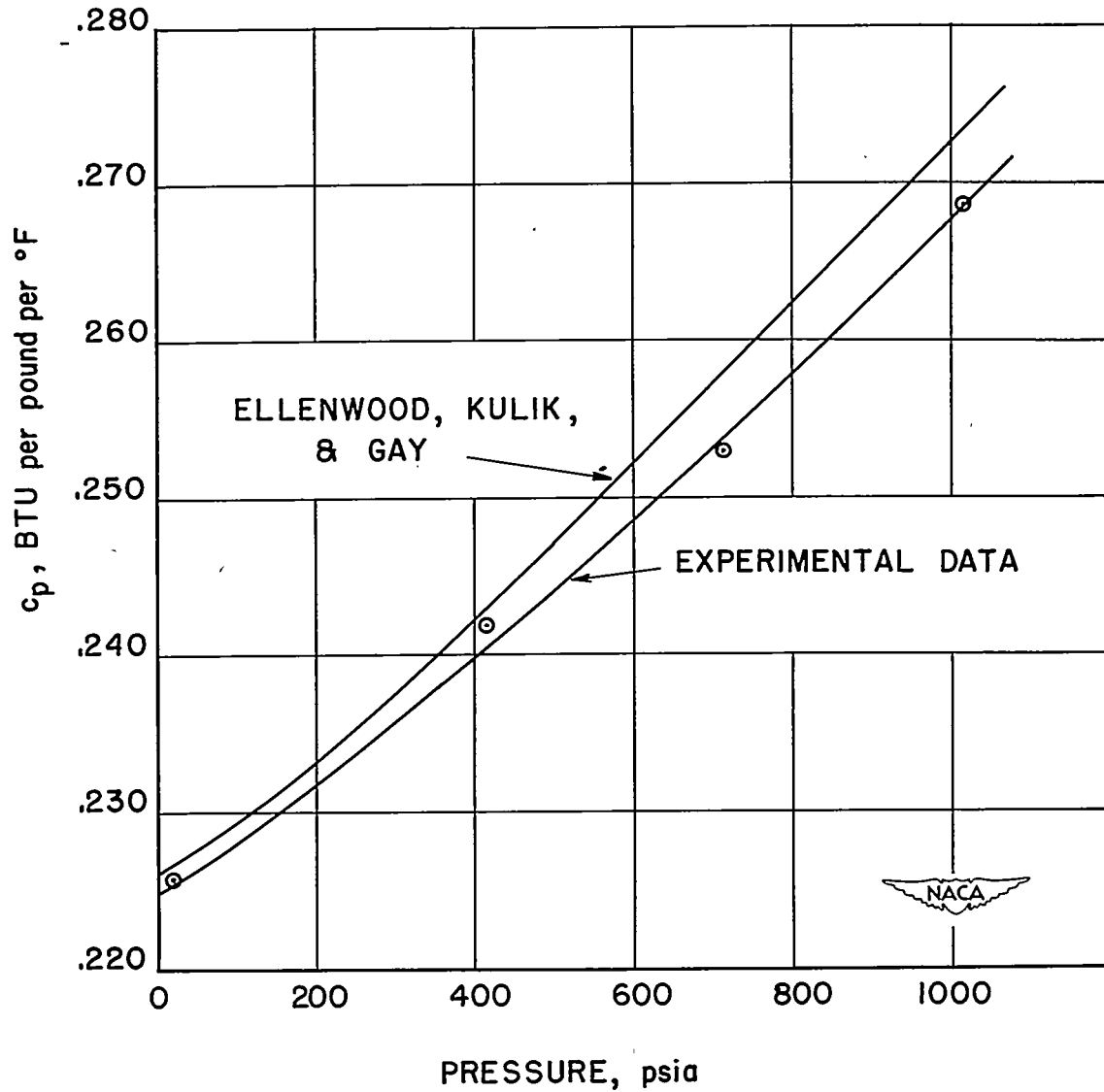

Figure 8.- Effect of pressure upon constant-pressure specific heat of carbon dioxide at 295° F.

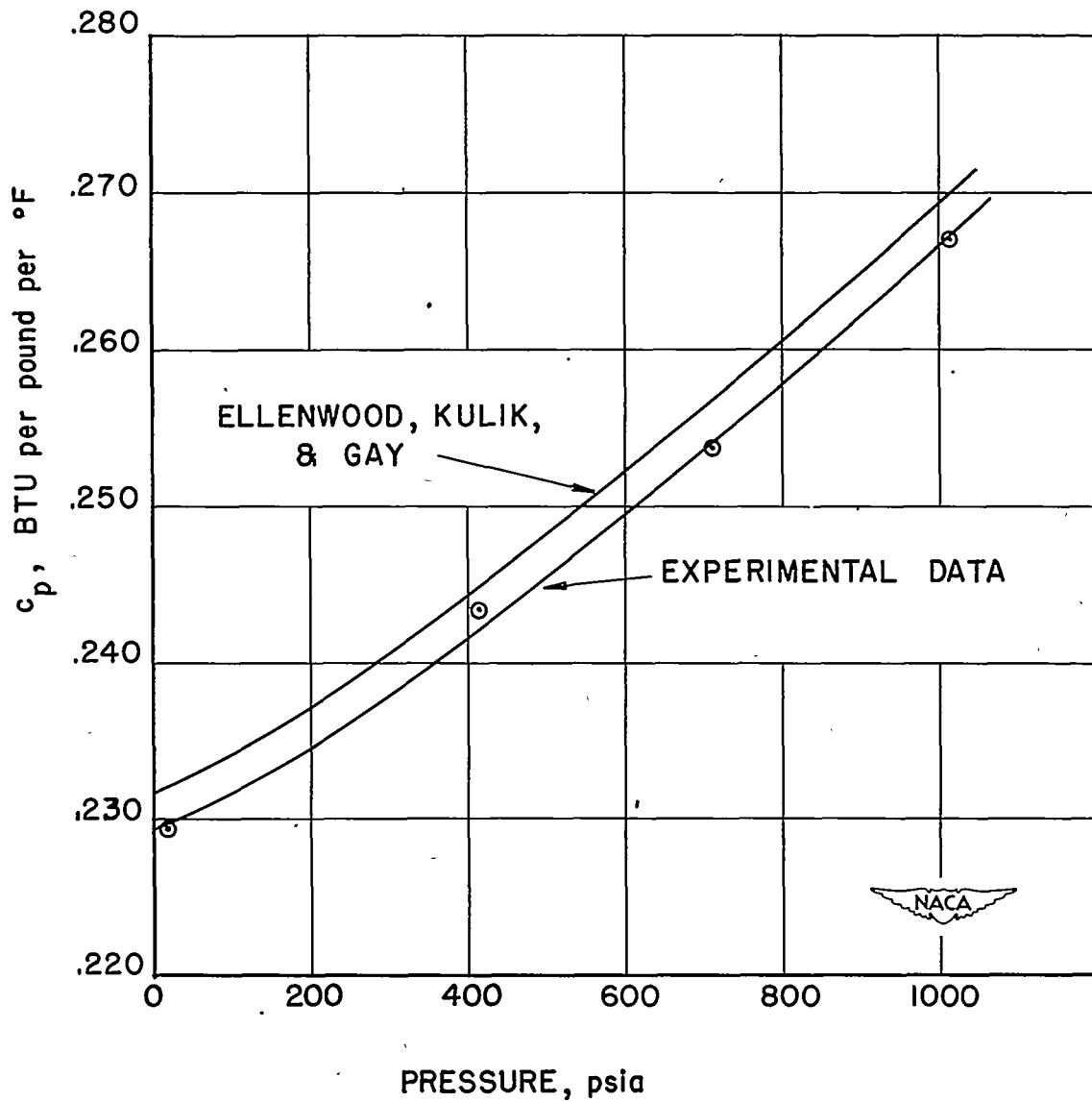

Figure 9.- Effect of pressure upon constant-pressure specific heat of carbon dioxide at 340° F.

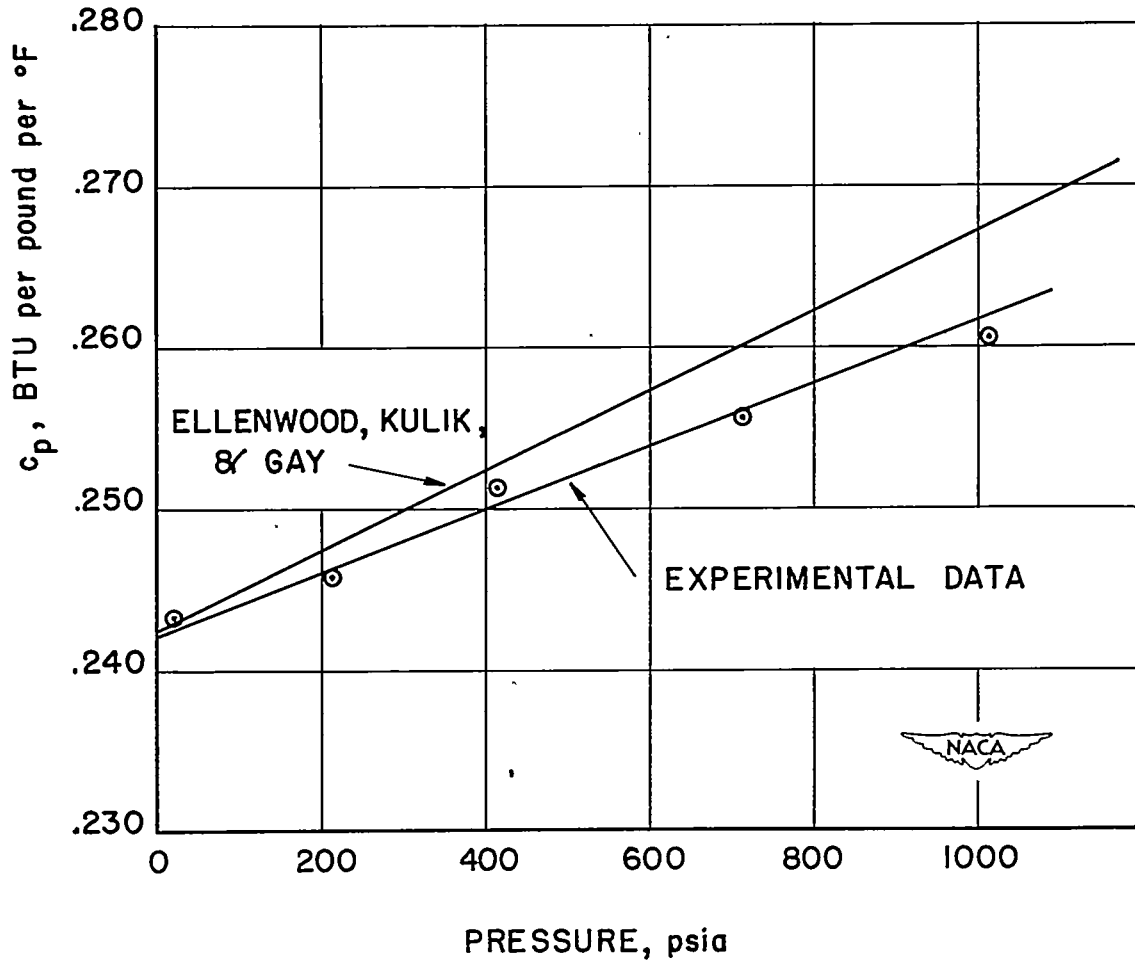

Figure 10.- Effect of pressure upon constant-pressure specific heat of carbon dioxide at 455° F.

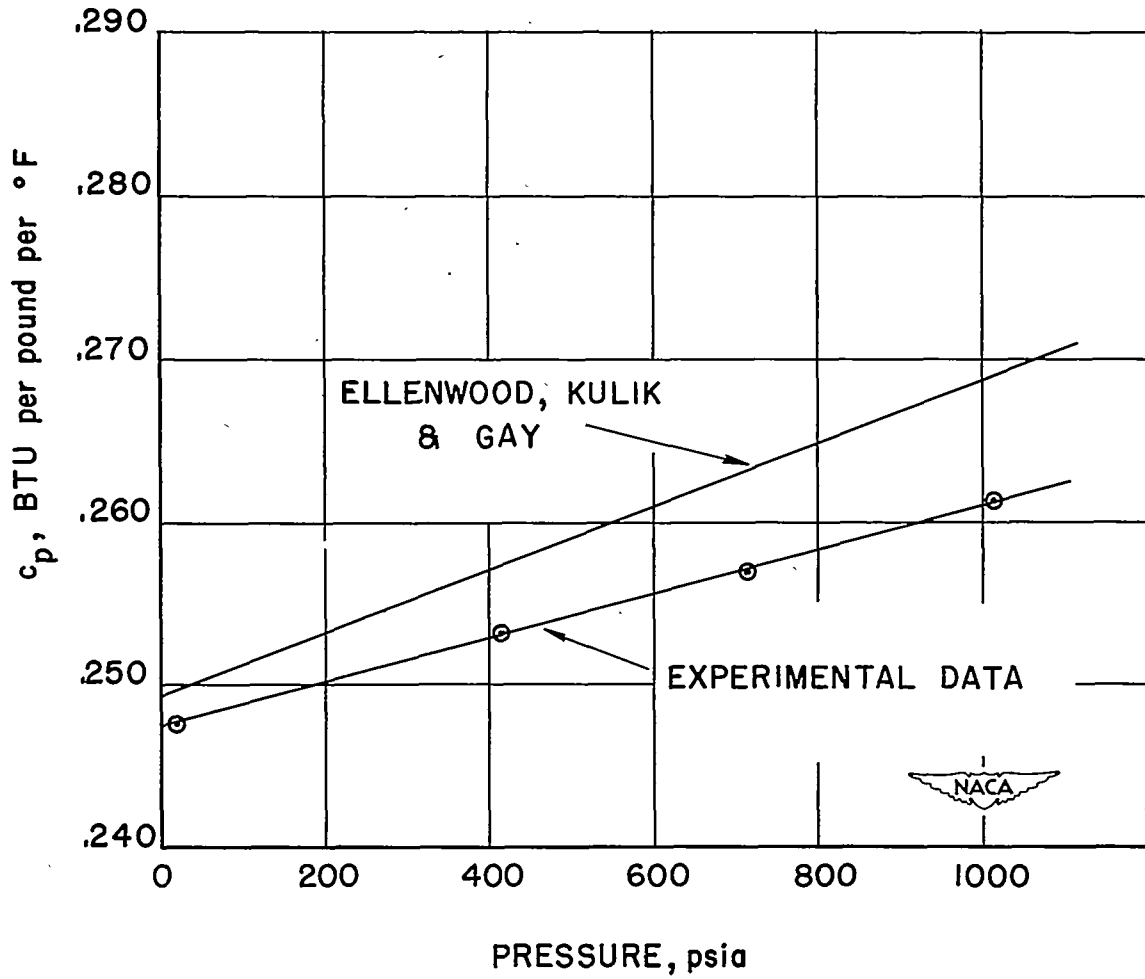

Figure 11.- Effect of pressure upon constant-pressure specific heat of carbon dioxide at 535° F.

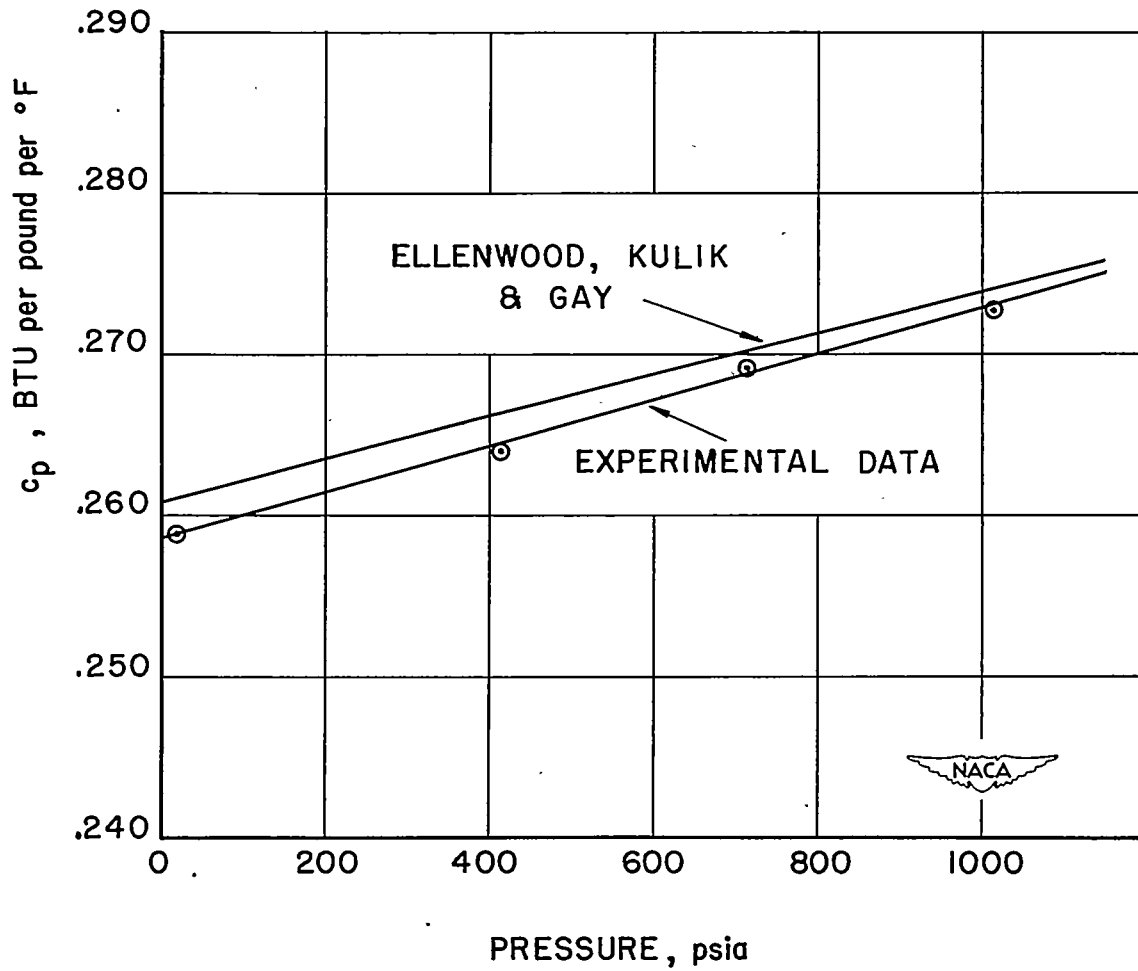

Figure 12.- Effect of pressure upon constant-pressure specific heat of carbon dioxide at 685° F.

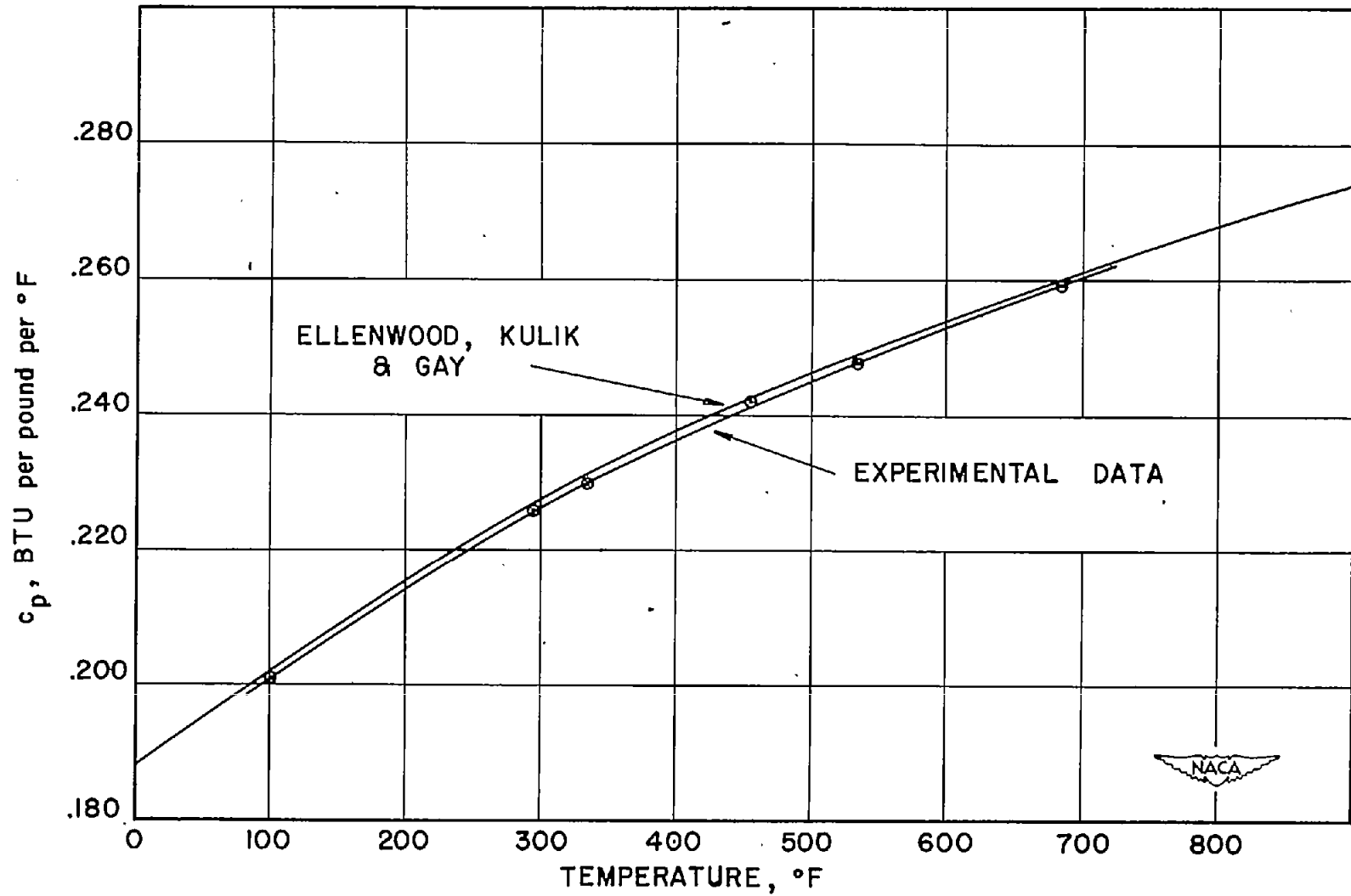

Figure 13.- Effect of temperature upon constant-pressure specific heat of carbon dioxide at zero pressure.

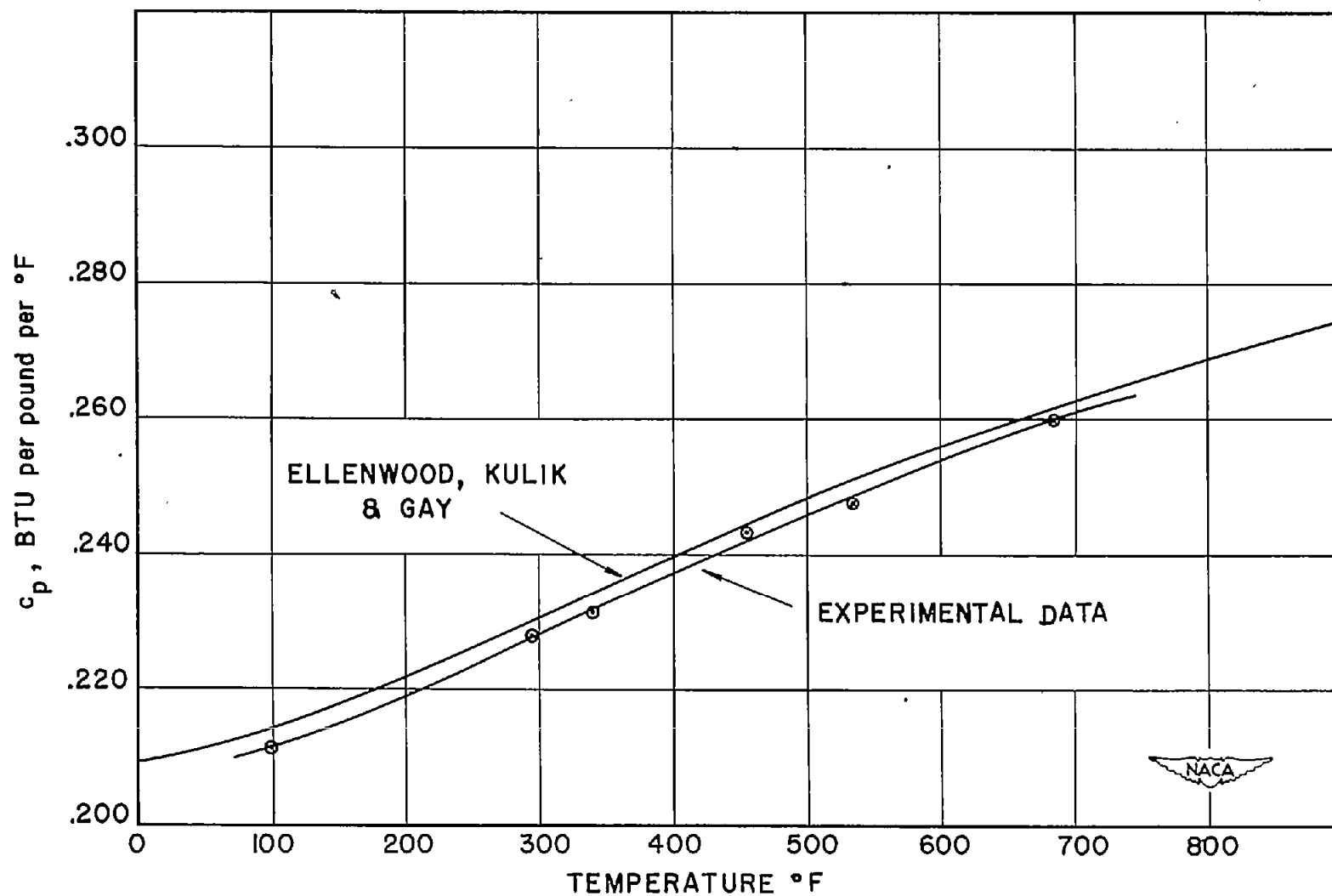

Figure 14.- Effect of temperature upon constant-pressure specific heat of carbon dioxide at 100 pounds per square inch absolute.

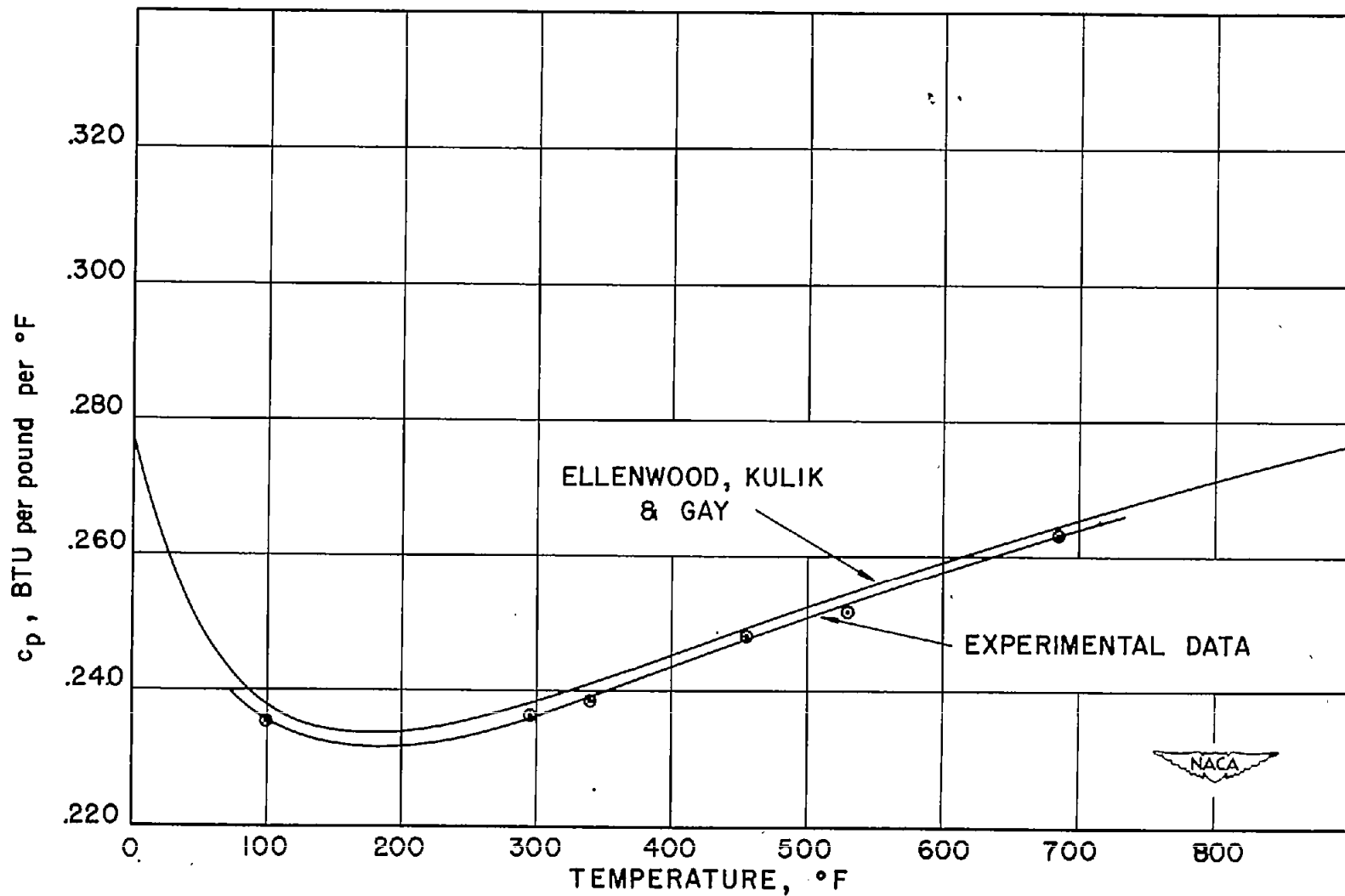

Figure 15.- Effect of temperature upon constant-pressure specific heat of carbon dioxide at 300 pounds per square inch absolute.

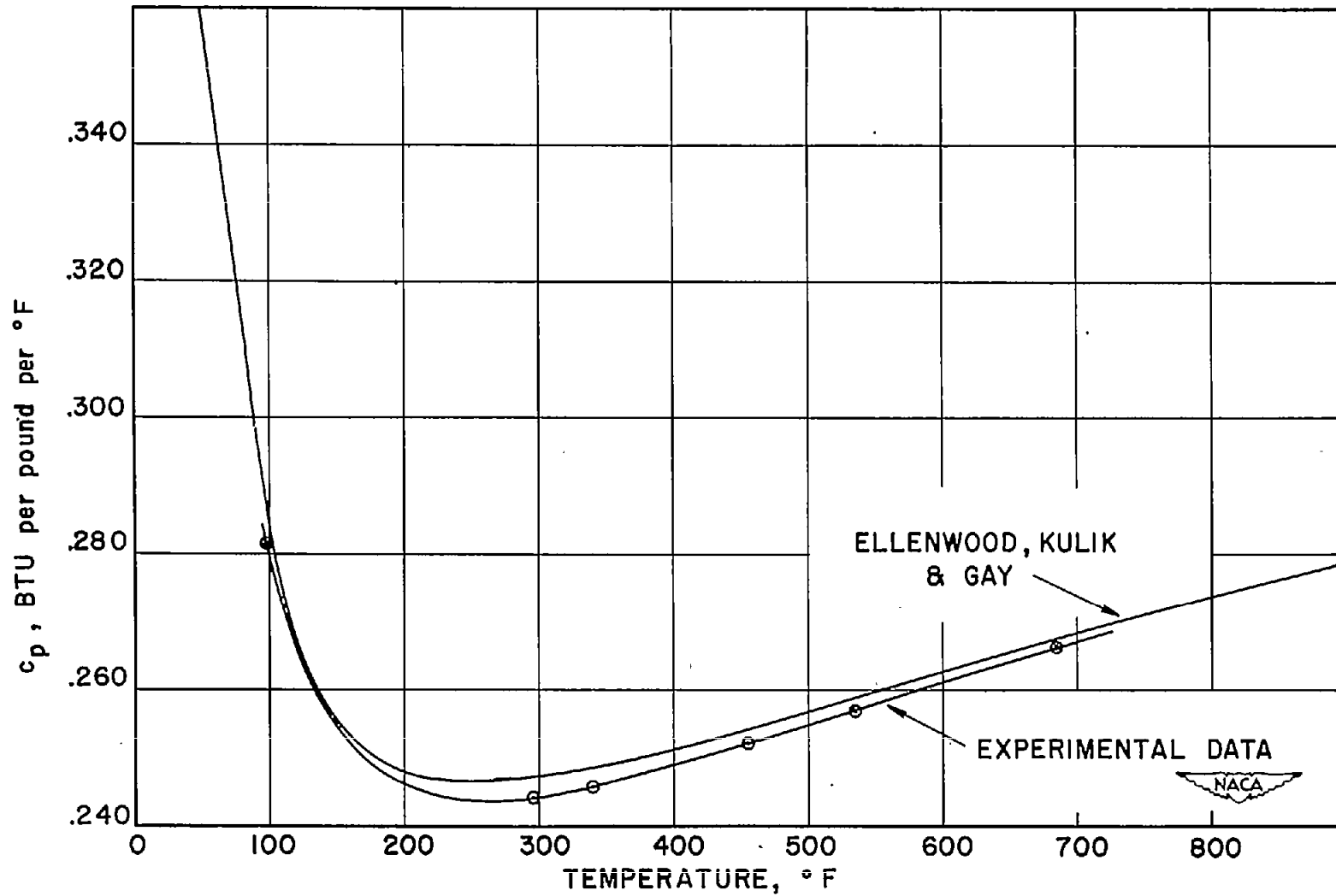

Figure 16.- Effect of temperature upon constant-pressure specific heat of carbon dioxide at 500 pounds per square inch absolute.

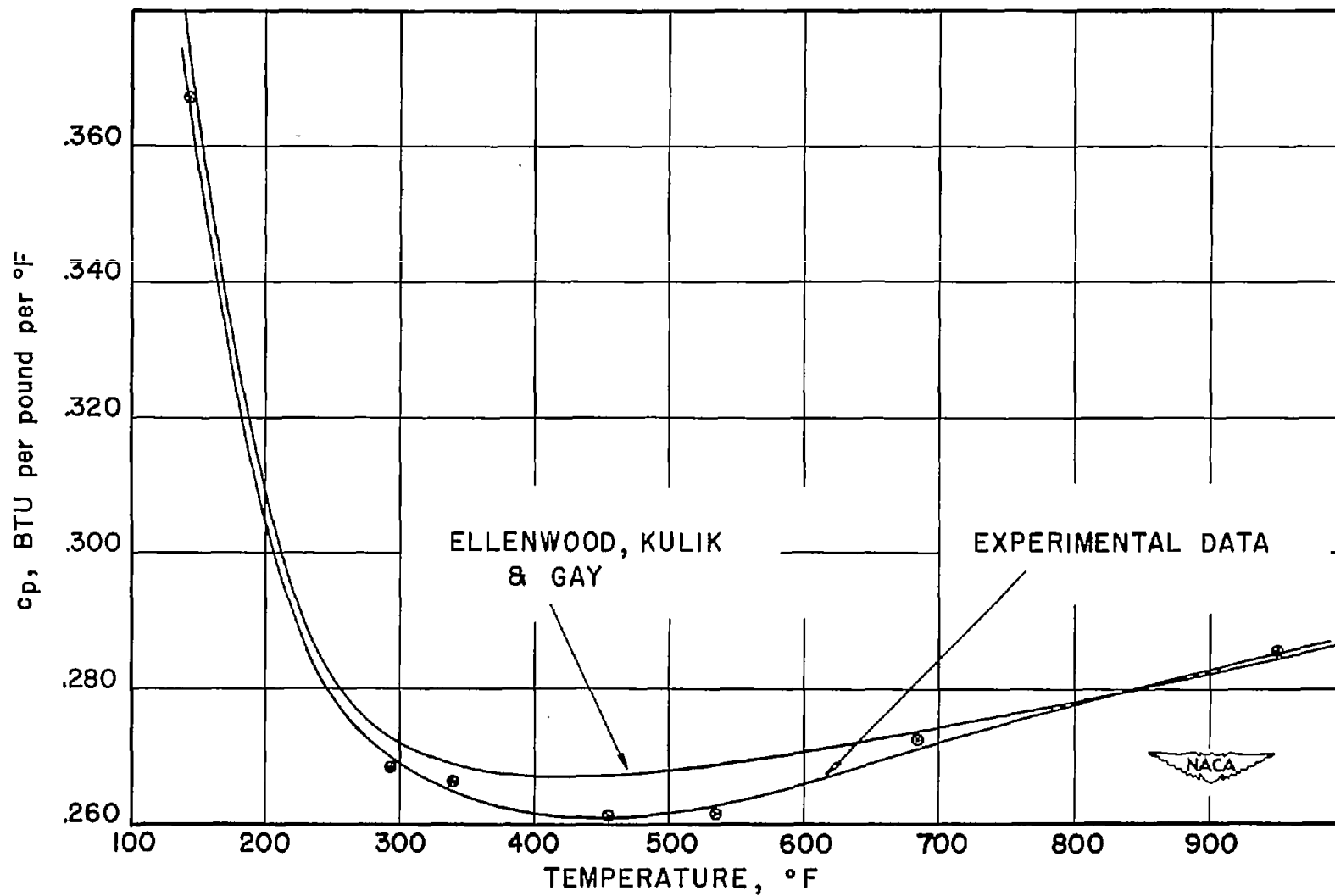

Figure 17.- Effect of temperature upon constant-pressure specific heat of carbon dioxide at 1000 pounds per square inch absolute.

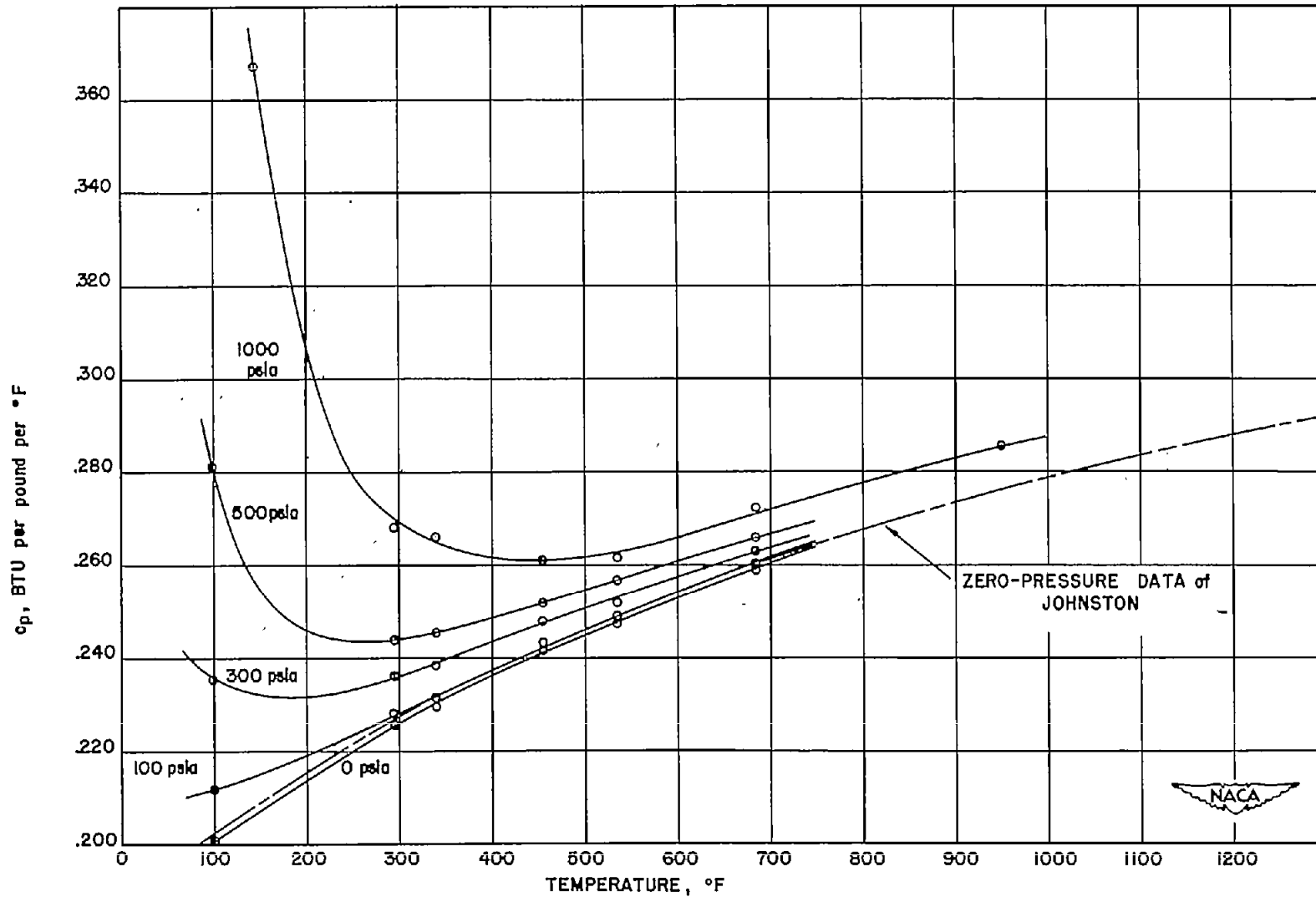

Figure 18.- Specific heat of carbon dioxide from experimental results.

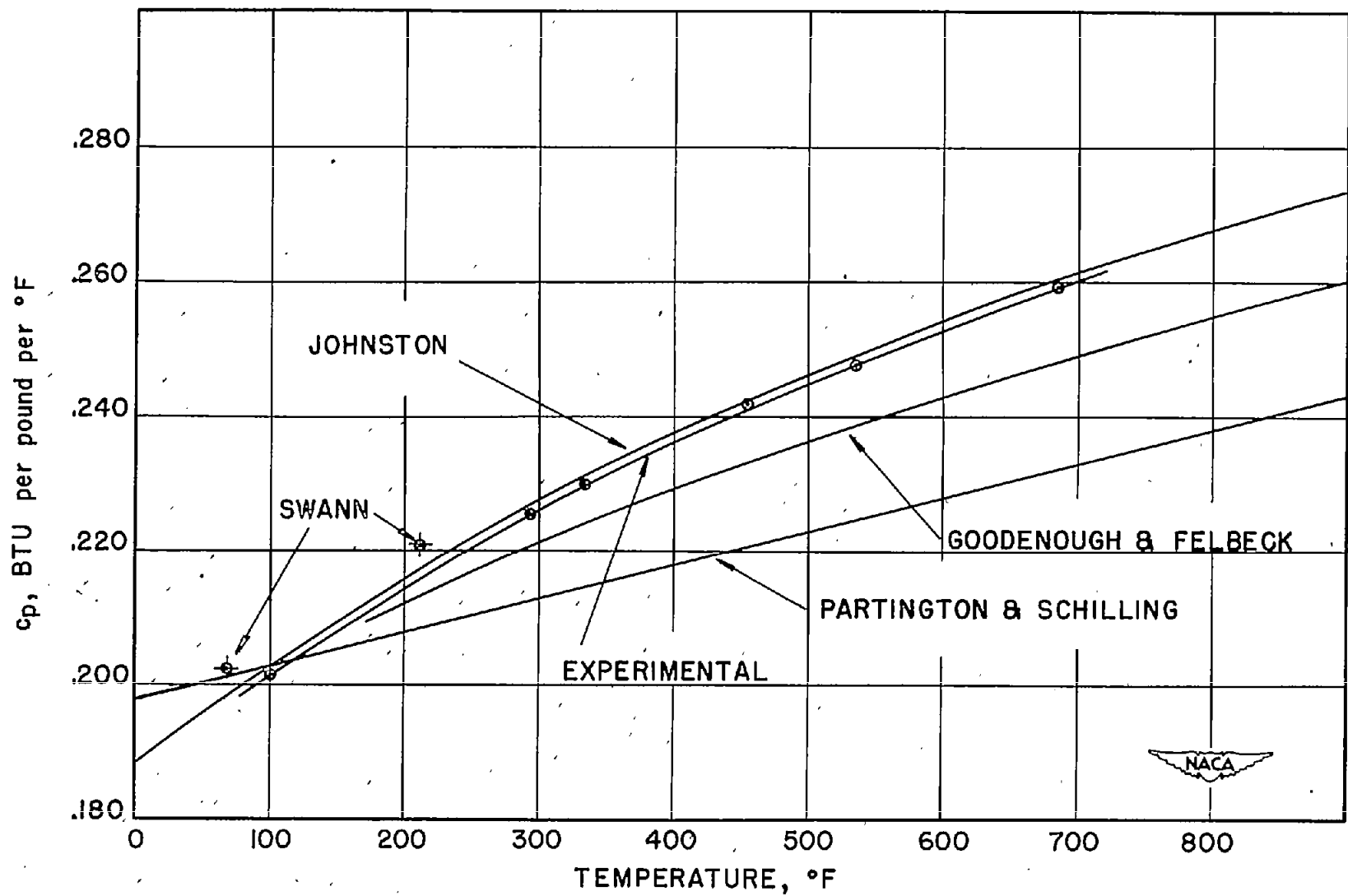

Figure 19.- Comparison of low-pressure data for carbon dioxide.

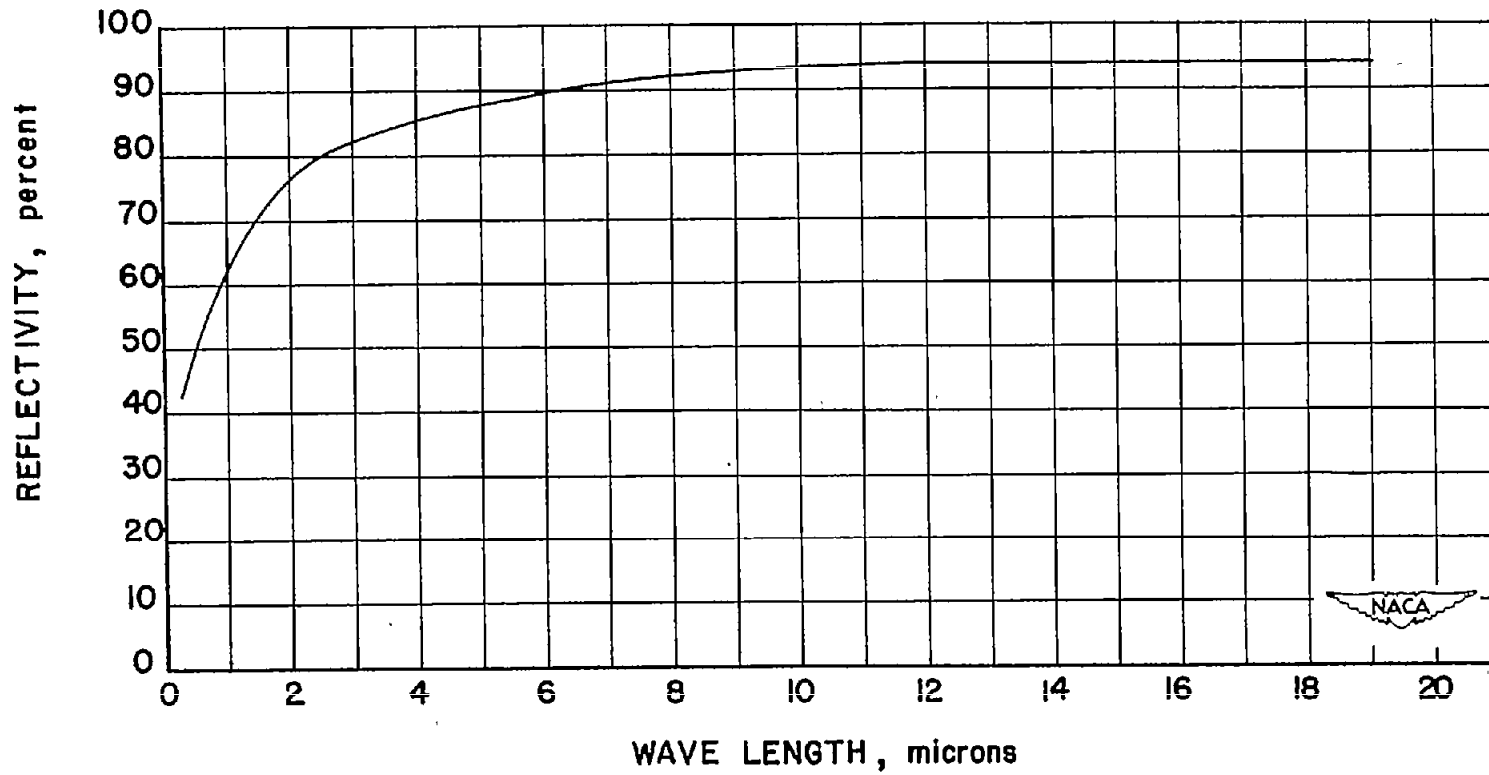

Figure 20.- Spectral reflectivity of Inconel.

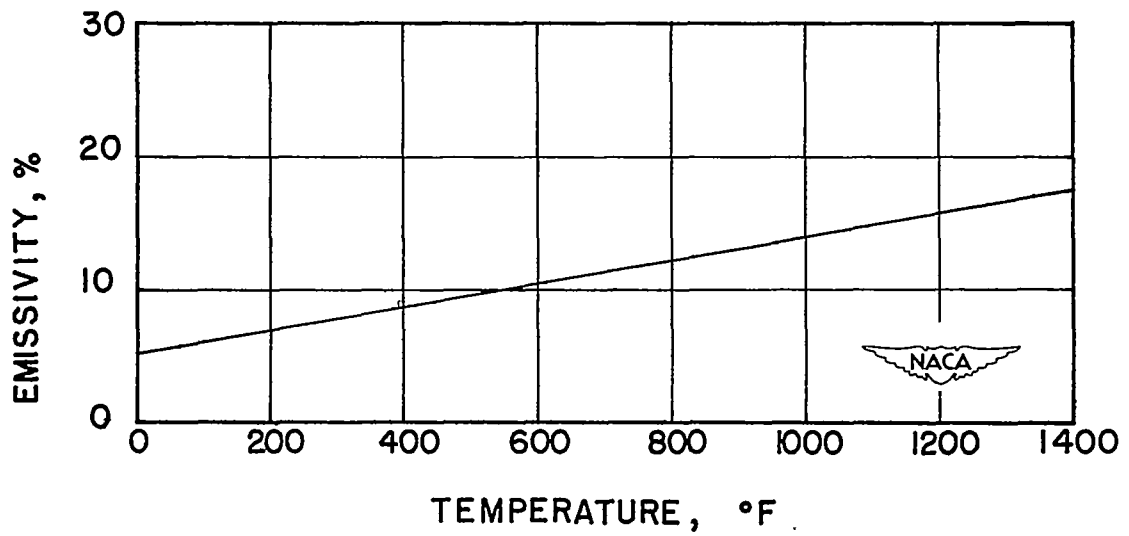

Figure 21.- Total emissivity of Inconel.

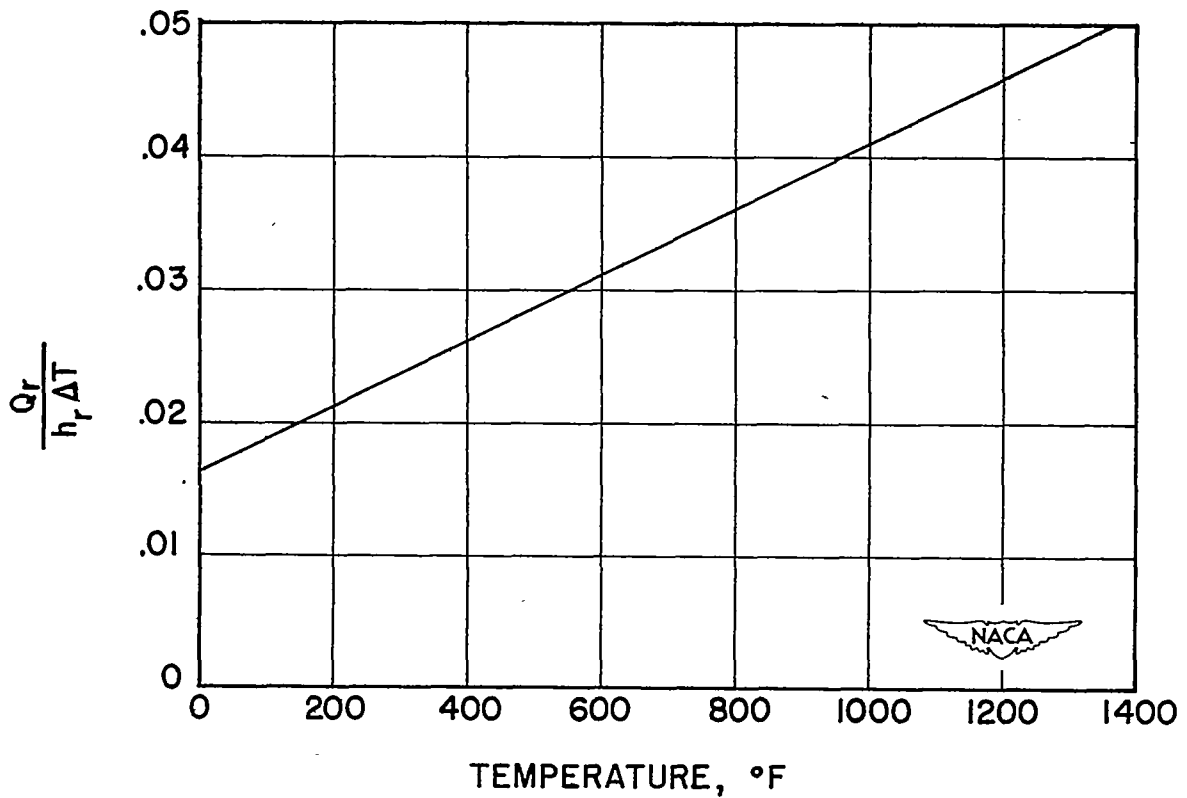

Figure 22.- Plot of temperature against $Q_r/h_r \Delta T$.

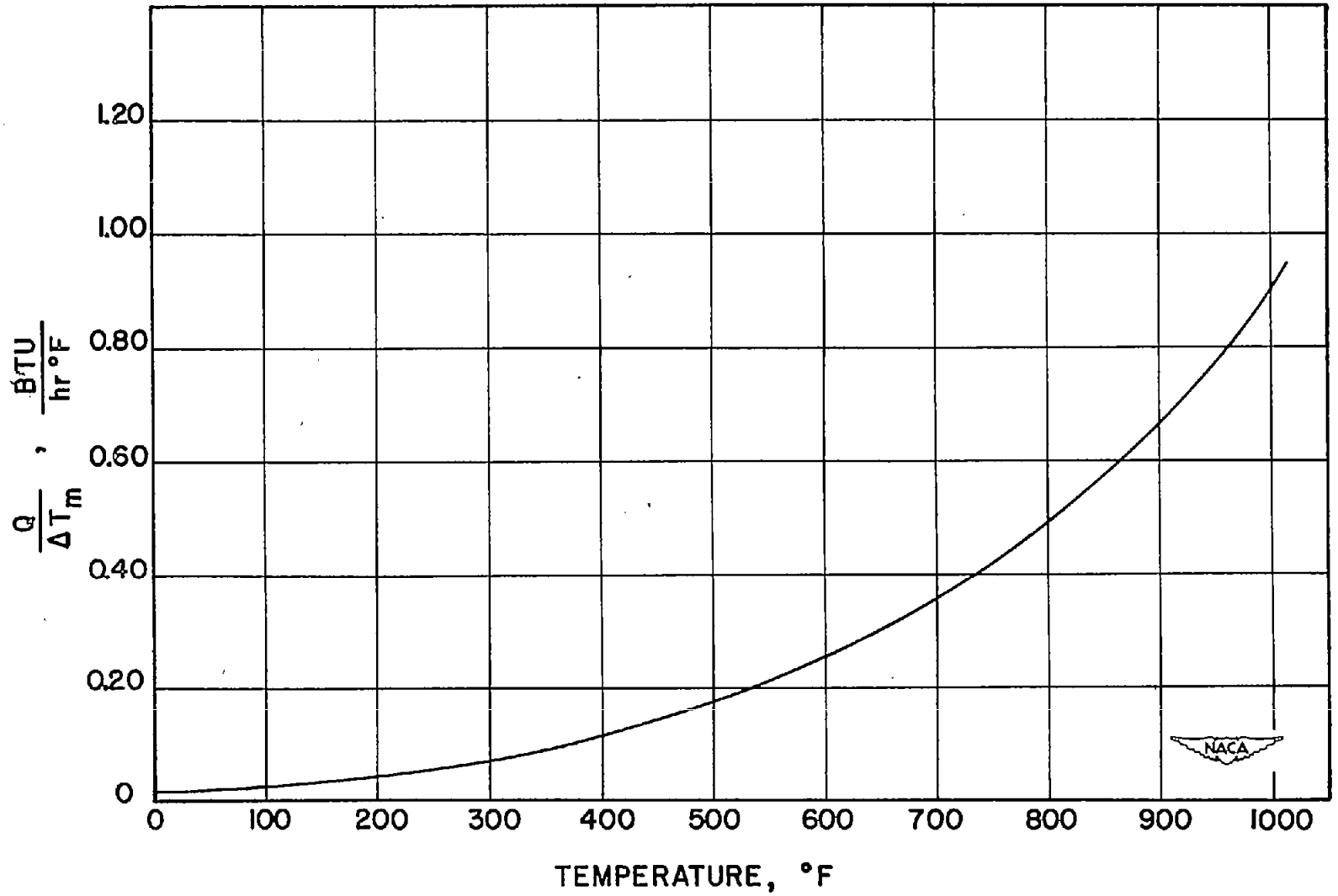

Figure 23.- Radiant heat loss from test section.