

NACA TN 2915

# NATIONAL ADVISORY COMMITTEE FOR AERONAUTICS

TECHNICAL NOTE 2915

EFFECT OF PROCESSING VARIABLES ON THE TRANSITION  
TEMPERATURE, STRENGTH, AND DUCTILITY OF  
HIGH-PURITY, SINTERED, WROUGHT  
MOLYBDENUM METAL

By Kenneth C. Dike and Roger A. Long

Lewis Flight Propulsion Laboratory  
Cleveland, Ohio



Washington

March 1953

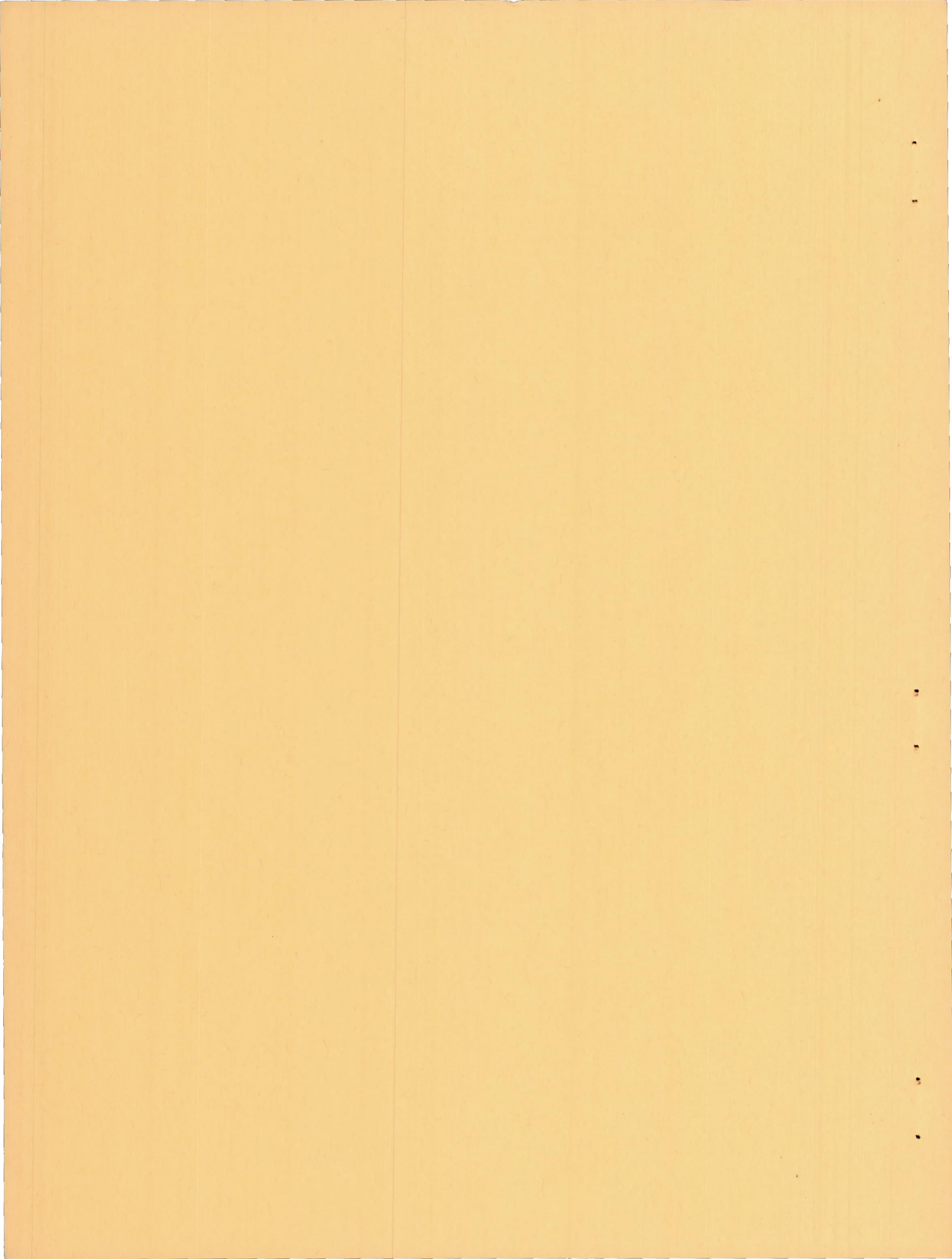

TECHNICAL NOTE 2915

EFFECT OF PROCESSING VARIABLES ON THE TRANSITION TEMPERATURE,  
STRENGTH, AND DUCTILITY OF HIGH-PURITY, SINTERED,  
WROUGHT MOLYBDENUM METAL

By Kenneth C. Dike and Roger A. Long

SUMMARY

An investigation was made of the effect of processing variables on the properties of sintered, wrought molybdenum. The amount of swaging, recrystallization, and stress-relieving were considered.

An increase in the swaging of molybdenum progressively lowers the transition temperature. Molybdenum swaged 99 percent has a transition range approximately 100° F lower than metal swaged 35 percent. The effect of swaging on the transition temperature range is nullified when molybdenum is recrystallized.

At room temperature, swaging to 99 percent had very little effect (13 percent) upon increasing the ultimate tensile strength over that of molybdenum swaged 35 percent. Stress relief caused a reduction in tensile strength of 3 to 6 percent. At room temperature, metal recrystallized after swaging had 22 to 26 percent less strength than the as-swaged material. Both as-swaged and recrystallized molybdenum show an increase in tensile strength as the temperature is decreased, irrespective of the amount of swaging.

The ductility of as-swaged molybdenum at room temperature was improved considerably by swaging 50 percent or more. Stress-relieving improved the ductility of the metal only if it had been given 50 percent or less swaging. The ductility of recrystallized metal from room temperature to about 200° F, given a prior 99 percent working, was double that of metal given a prior 35 or 50 percent working.

All the material evaluated in tension, irrespective of the amount of swaging, whether in the as-swaged, stress-relieved, or recrystallized state showed a transgranular fracture at all temperatures.

No relation could be established between the grain size of recrystallized metal and the strength and ductility, within the transition temperature range, in the grain count range of 75 to 825 grains per square millimeter. However, above the transition range, for example, at 200° F, ductility increased with decreasing grain size.

## INTRODUCTION

There is an increasing current interest in commercially pure molybdenum made by both the powder-sintering method and arc-casting. Considerable data are now available on the mechanical properties of metal produced by both methods, but, unfortunately, these data are in many instances contradictory and not reproducible. So-called ductile molybdenum is made by both manufacturing methods, but frequently ductility is low or absent. This variation in ductility at room temperature is of vital importance if molybdenum is to be used in load-bearing applications.

Since molybdenum has a body-centered cubic crystal lattice, it had been suspected to have a critical transition temperature (the temperature at which the fracture of a metal reverts from a ductile to a brittle break) similar to that found in iron and steel. The existence of such a transition temperature in molybdenum has now been established in the work reported in reference 1. This work shows that a transition temperature occurred below room temperature for metal obtained by both powder-metallurgy and arc-casting methods.

Since this transition occurred fairly close to room temperature, there is a possibility that data showing little or no ductility were procured from material tested at or below the transition temperature. The data of the literature (ref. 2) also show that some lots of molybdenum are room-temperature ductile in the fibrous state; however, after recrystallization they become brittle (less than 1 percent elongation).

In view of this behavior of molybdenum, an investigation was initiated at the NACA Lewis laboratory primarily to determine the effect of prior swaging (prestrain) on the position of the transition temperature, which may make the difference between a ductile and a brittle material at or near room temperature.

The investigation included the following parts:

- (1) The effect of swaging reduction on the transition temperature of molybdenum in the as-swaged and recrystallized states
- (2) The effect of swaging reduction on the strength and ductility of molybdenum in the as-swaged and recrystallized states

- (3) Types of fracture
- (4) The influence of grain size on strength and ductility of recrystallized molybdenum

## MATERIAL PROCESSING

A  $1\frac{1}{8}$ - by  $1\frac{1}{8}$ - by 24-inch, cold-pressed, sintered molybdenum ingot was swaged by conventional commercial methods into a 0.225-inch-diameter rod. This rod was then cut into three equal lengths. Each rod was further processed to obtain three end products of equal diameter, but possessing various amounts of induced strain, as shown in the following flow sheet. Since the swaging had to be interrupted at different diameters in order to obtain finished products possessing various amounts of strain, it was necessary to determine the possibility of an effect of this variable on the final bars. Therefore, the strength and ductility of bars swaged to 0.155 and 0.177 inch diameters were checked before and after recrystallization. Both possessed similar mechanical properties (table I).

## PROCESSING FLOW SHEET

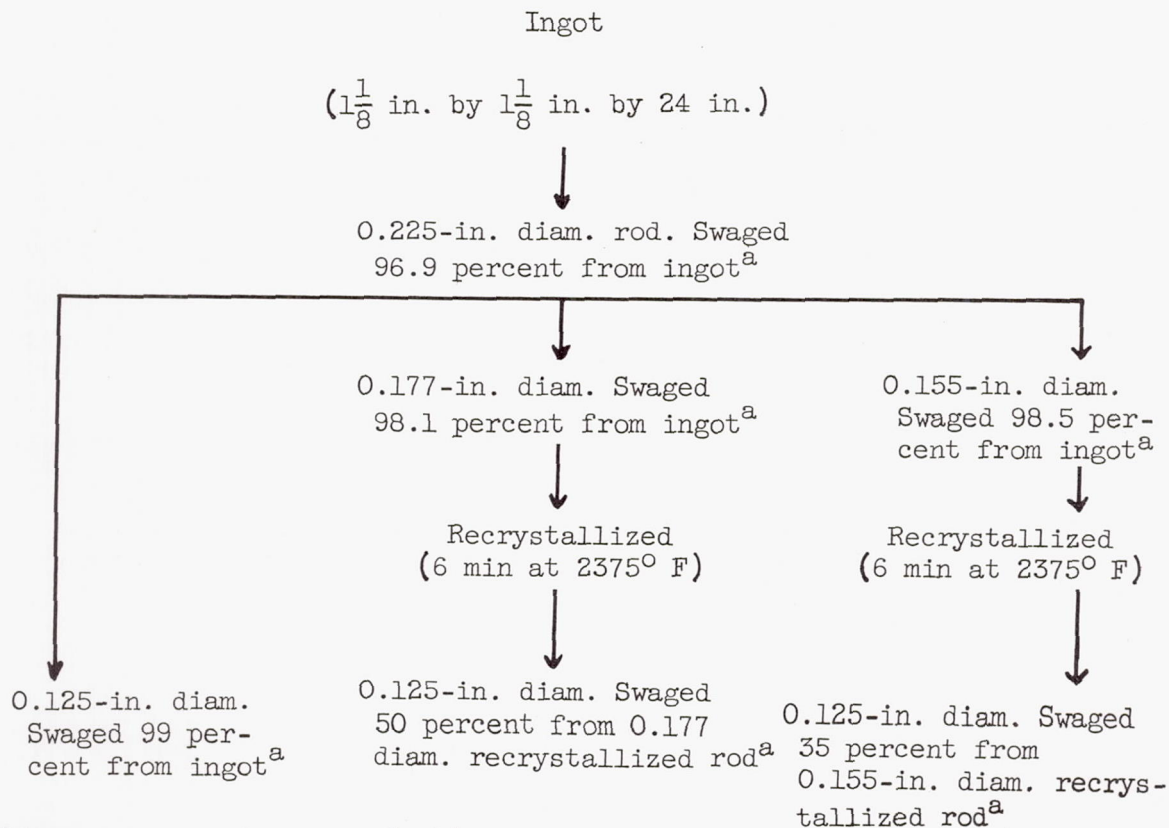

Photomicrographs of structural changes occurring at each processing step are shown in figure 1 and chemical analysis of the final product is given in table II.

All swaging from 0.225-inch diameter to 0.125-inch diameter was done between 1525° and 1750° F, which was below the recrystallization temperature of any of the materials at any point in the processing. The final swaging pass for all the 0.125-inch diameter bars was made at 1525° F. The metal was recrystallized by heating for 6 minutes at 2375° F in a reducing atmosphere.

#### DESCRIPTION OF APPARATUS

Tensile-testing machine. - A commercial hydraulic-type tensile machine with a low scale of 6000-pound load capacity was used to evaluate tensile specimens. Templin-type grips were used. A stress-strain recorder was used to obtain data to compute 0.2-percent offset yield strengths.

Furnace. - The specimens were heated in a Nichrome-wound, resistance-type, tube furnace (fig. 2) which was sealed at both ends with a metal cover and cement. A gas inlet tube at the top provided a flow of helium sufficient to prevent any damaging oxidation of the specimens.

Liquid bath. - A small, insulated container was used to hold both the tensile specimens and liquids for tensile testing from -150° to 350° F (see fig. 3).

Temperature instrumentation. - Temperatures above 500° F were recorded with a potentiometer-pyrometer using three thermocouples placed against the tensile specimen test section. The maximum variation in temperature was  $\pm 10^\circ$  F at the 1800° F evaluation temperature. Temperatures below 500° F were measured with thermometers. Maximum temperature variations of  $\pm 2^\circ$  F were attained.

Tensile specimens. - The tensile specimens used are shown in figure 4. The test section surface was finish ground to 5 to 16 rms.

#### PROCEDURE

Heating. - Evaluation temperatures above 500° F were attained as shown in the following table and held for 10 minutes for temperature stabilization.

Testing temperature, °F	Time to reach temperature, min
600	20 <sub>+5</sub>
900	30 <sub>+5</sub>
1200	40 <sub>+5</sub>
1800	90 <sub>+10</sub>

Temperature control was obtained manually with a variable transformer. Temperatures up to 350° F were attained by preheating oil on a hot plate and pouring into the bath apparatus which contained the tensile specimen. A soaking time of 5 minutes was allowed for temperature uniformity during which time the oil was constantly agitated. The thermometer was placed adjacent to the middle of the test section. The temperature fluctuation during loading of the specimens was a maximum of +2° F.

Cooling. - The materials used to cool tensile specimens evaluated below room temperature are as follows:

Testing temperature range, °F	Liquid medium	Solid coolant
-150 to -110	Acetone	Metal precooled in liquid nitrogen
-110 to -50	Acetone	Carbon dioxide
-50 to 0	Naphtha solvent	Carbon dioxide
0 to 33	Calcium chloride in water	Carbon dioxide
33 to 70	Water	Ice

The cold liquids were first prepared in a beaker and then poured into the bath. Additional solid coolant was then added with constant stirring for approximately 2 minutes, during which time the desired temperature was obtained. An additional 2 minutes, with constant agitation, was then allowed for temperature uniformity between the liquid and the specimen. The maximum temperature variation during loading was +2° F.

Rate of loading. - An approximate rate of loading of 300 pounds per minute (47,500 lb/(sq in.)(min.)) was used for all tensile specimens up to the point where the load began to fall off.

Ductility measurements. - Percentages of elongation were calculated by using a gage length of 1.25<sub>+0.02</sub> inches (see fig. 4). The maximum

2689

error in the elongation values is  $\pm 0.5$  percent. Reduction in areas of recrystallized specimens were calculated from the original diameter and the final diameters at the fracture.

Heat treatment. - All tensile specimens which were stress-relieved or recrystallized were processed in a dry hydrogen atmosphere with a dew point of  $-45^{\circ}$  or less. Times and temperatures are noted in table I.

Metallography. - The metallographic techniques used to produce the photomicrographs are detailed in reference 3. Grain count and size determinations were made on transverse surfaces by the Jeffries' method (ref. 4).

6892

## RESULTS AND DISCUSSION

Effect of swaging reduction on transition temperature of molybdenum in as-swaged and recrystallized states. - Figure 5 shows that molybdenum does not revert rapidly from a ductile to a brittle material as the temperature is decreased. In view of this, the transition temperature has been defined as occurring over a range of temperatures. This range was determined arbitrarily as lying between those temperatures at which the metal had one-third and two-thirds its maximum ductility over the evaluated range. This method afforded a convenient means of establishing a correlation of the data. Table III lists the transition ranges established by this method, taken from figures 5 and 6. The data readily indicate that swaging has an appreciable effect upon the position of the transition range. There was a differential of approximately  $100^{\circ}$  F between the 99 and the 35 percent swaged metal. In this lot of material, the highly swaged metal would be acceptable from the standpoint of ductility at room temperature, but the 35 percent swaged metal might be considered unsatisfactory or borderline.

Since the transition ranges for recrystallized metal are all grouped closely together, it is evident that prior swaging effects on lowering the range have been nullified by recrystallization. Recrystallization changes the mean of the transition range:  $87^{\circ}$  F for 99 percent swaged metal,  $35^{\circ}$  F for the 50 percent swaged metal, and  $-13^{\circ}$  F for 35 percent swaged metal. The drop of  $13^{\circ}$  F is small and indicates that the 35 percent swaging reduction is not severe enough to lower the transition temperature of molybdenum; however, it is interesting to note (fig. 7) that the 35 percent swaged, stress-relieved metal has a ductility value greater than the 99 percent swaged material. Figure 8 is presented in order to compare more clearly the properties of as-swaged metal and recrystallized metal over the evaluation range for the different percentages of swaging reduction.

Reductions in area of recrystallized specimens were plotted against temperature and showed the same trends as the elongation curves in



figure 6. If the transition range is computed on the basis of reduction of area it is approximately the same or a little higher than when computed on the basis of elongation. This comparison could not be made with as-swaged metal because of the tendency of as-swaged metal to form a severe tearing-type fracture, irrespective of the percentage elongation, making a measurement of reduction in area grossly inaccurate.

A transition temperature range has been definitely established for molybdenum, and it has been shown that prestrain (swaging) has an influence on the position of this range. It is known that heat treatments can also influence the position; however, in a fully annealed or recrystallized condition, other factors still exist which vary the transition range from one lot of molybdenum to another.

Considerable data exist showing recrystallized molybdenum to be brittle at room temperature and other data, showing the same type of material to possess excellent ductility. This discrepancy may stem from materials having different transition temperatures. Some element may be present in molybdenum in a minute amount which may have a pronounced effect upon the position of the transition temperature. It is well-known that small amounts of impurities in many alloys have the ability to change their mechanical and physical properties considerably. Of particular concern was the amount of residual gases which might be present in the metal; therefore, the metal was analyzed for oxygen, nitrogen, and hydrogen by using a vacuum fusion method perfected by Battelle Memorial Institute and believed to be the most accurate method presently available. Table II lists the analysis in percentage by weight and also the accuracy of the determination. A comparison was made with other analyses in the literature, which were obtained by the same analytical methods at the same laboratory, and no significant trend was observed which could account for the difference in properties of various lots of molybdenum.

A semiquantitative spectrographic analysis was made for elements possibly present in small quantities, but no significance could be attached to these results. The uranium content (0.1 percent) seemed rather high; however, other lots of molybdenum investigated also were reported as having the same amount of uranium. This element is excluded as a factor since the lots mentioned had different properties.

Battelle Memorial Institute (ref. 5) reports that prestraining, or swaging as defined in this investigation, has little or no effect upon the position of the transition temperature. Their method of evaluation utilized transverse bend specimens, whereas the method utilized at the NACA used ground tensile specimens. The conclusion of reference 5 was based on metal which was prestrained over a range much lower than that used in this investigation. The cross-sectional area reductions of their rolled plate range from only 11 to 39 percent as a maximum, assuming no increase in width during rolling. If there was an increase in width, the percentage reductions would be less. The data of the present investigation

show that prestraining has a decreasing effect upon the transition temperature as prestraining is decreased and becomes negligible at 35 percent reduction. This confirms their conclusion if it be limited to the lower amounts of reduction.

Effect of swaging reduction on strength and ductility of molybdenum in as-swaged and recrystallized states. - It was found (fig. 7) that there was little effect (13 percent increase) of swaging from 35 to 99 percent on the strength of as-swaged molybdenum at room temperature. This effect was also observed over the range of temperature from  $-100^{\circ}$  to  $200^{\circ}$  F. Figure 5 shows that there is a uniform increase of strength with decreasing temperature down to  $-100^{\circ}$  F for the 99 and 50 percent swaged materials. The effect of temperature on the 35 percent prestrained metal is less pronounced at the lower temperatures, possibly because of the alinement problems of testing brittle materials. This strength and temperature relation also holds for recrystallized metal evaluated over the same temperature range (fig. 6). Material swaged 99 percent is the strongest at all temperatures and at room temperature is approximately 13 percent stronger than material swaged only 35 percent. Stress-relieved metal has tensile strengths 3 to 6 percent lower than as-swaged metal. Recrystallized metal has 22 to 26 percent less strength than as-swaged metal at room temperature.

6882

Although swaging from 35 to 99 percent is not very effective in improving the strength properties of molybdenum, it markedly improves the ductility in certain temperature ranges. Figure 5 shows that heavily swaged metal retains good ductility at far lower temperatures than does lightly swaged material. However, it may be noted that material swaged 35 percent and stress-relieved has a room temperature ductility 4 percent higher than the metal swaged 99 percent. Above the transition temperature range at  $175^{\circ}$  F, the ductilities are within 5 percent of each other, which also holds true at  $1800^{\circ}$  F. Recrystallized material has almost the opposite characteristics. Various prior amounts of swaging have little or no effect upon the ductility below the transition temperature range (fig. 6). However, above the transition temperature range, heavily swaged recrystallized metal evidently retains some property, probably induced by prior swaging, even though the material was totally recrystallized, which approximately doubles the ductility over that of lightly swaged metal in the range of from about room temperature to  $200^{\circ}$  F. Although grain size can be correlated with ductility above the transition temperature, it appears that this great difference in ductility could also be attributed to grain orientation or to subgrain structure. It is not known whether the superior ductility is retained at elevated temperatures, but tests at temperatures ranging up to  $1500^{\circ}$  F show a tendency for it to remain constant or to decrease slightly. For example, at  $900^{\circ}$  F, an elongation of 42 percent was recorded; while at  $1500^{\circ}$  F an elongation of 37 percent was obtained.

Types of fracture. - All the material evaluated, irrespective of the amount of swaging, whether in the as-swaged, stress-relieved, or recrystallized state showed a transgranular fracture at all temperatures. Below the transition range all fractures were of a brittle nature, and the rupture occurred straight across the tensile specimen without any longitudinal tearing. Figure 9 illustrates a typical break of this nature. Above the transition temperature range, where there is much greater ductility, all material had a tendency to develop large intergranular longitudinal splits; but the metal in the fracture plane still failed transgranularly. Figure 10 illustrates typical fractures of this nature. Within the transition temperature range both types of fracture were observed with no discernible relation to the ductility.

Influence of grain size on strength and ductility of recrystallized molybdenum. - No relation is shown in figure 11 between recrystallized grain size and strength and ductility at room temperature, which happens to lie within the transition range, in the grain count range of 75 to 825 grains per square millimeter. However, above the transition range, for example, at 200° F, a direct relation exists between ductility and grain size, with ductility increasing with decreasing grain size. Whether this relation continues at higher temperatures is not known. Previous conclusions on grain-size effects may have been drawn without recognition of the tremendous effects of transition temperature on such correlations.

Bechtold and Scott (ref. 1) state that "molybdenum has high cold ductility as fully annealed only when it is in the fine-grained condition." The metal they used had a grain size ranging from 1200 to 1650 grains per square millimeter. Another lot of 10 percent swaged molybdenum which had exceptionally large grains (average, 7 grains/sq mm) was evaluated at the Lewis laboratory under testing conditions identical to those used in this report. This lot was also in the fully recrystallized condition and when evaluated possessed an elongation of about 15 percent at room temperature. Therefore, it can be stated that coarse-grained metal can have cold ductility.

#### SUMMARY OF RESULTS

The following results were obtained from an investigation of the effect of processing variables on the properties of sintered, wrought molybdenum:

1. An increase in the swaging of molybdenum progressively lowers the transition temperature. Molybdenum swaged 99 percent has a transition range approximately 100° F lower than metal swaged 35 percent. The effect of swaging on the transition temperature range is nullified when molybdenum is recrystallized.

2. At room temperature, swaging to 99 percent had very little effect (13 percent) upon increasing the ultimate tensile strength over that of molybdenum swaged 35 percent. Stress-relieved metal had tensile strengths 3 to 6 percent lower than as-swaged metal. At room temperature, metal recrystallized after swaging had 22 to 26 percent less strength than the as-swaged material. Both as-swaged and recrystallized molybdenum show an increase in tensile strength as the temperature is decreased, irrespective of the amount of swaging.

3. The ductility of as-swaged molybdenum at room temperature was improved considerably by swaging 50 percent or more. Stress-relieving improved the ductility of the metal only if it had been given 50 percent or less swaging. The ductility of recrystallized metal from room temperature to about 200° F, given a prior 99 percent working, was double that of metal given a prior 35 or 50 percent working.

4. All the material evaluated in tension, irrespective of the amount of swaging, whether in the as-swaged, stress-relieved, or recrystallized state showed a transgranular fracture at all temperatures.

5. No relation could be established between the grain size of recrystallized metal and strength and ductility, within the transition temperature range, in the grain count range of 75 to 825 grains per square millimeter. However, above the transition range, for example, at 200° F, ductility increased with decreasing grain size.

Lewis Flight Propulsion Laboratory  
National Advisory Committee for Aeronautics  
Cleveland, Ohio, November 7, 1952

#### REFERENCES

1. Bechtold, James H., and Scott, Howard: Mechanical Properties of Arc-Cast and Powder Metallurgy Molybdenum. Scientific Paper 1586, Westinghouse Research Labs., East Pittsburgh (Pa.), March 28, 1951.
2. Parke, Robert M.: Molybdenum-A New High-Temperature Metal. Metal Progress, vol. 60, no. 1, July 1951, pp. 81-96.
3. Long, R. A., Dike, K. C., and Bear, H. R.: Some Properties of High-Purity Sintered Wrought Molybdenum Metal at Temperatures up to 2400° F. NACA TN 2319, 1951.
4. Anon.: A.S.T.M. Standards 1942. Part I. Metals. A.S.T.M., Philadelphia (Pa.), 1943, pp. 1475-1477.
5. Anon.: A Metallurgical Study of Molybdenum. Tenth Quarterly Status Rep., Aug. 1 - Oct. 31, 1951, Battelle Memorial Institute, Columbus (Ohio), Nov. 1, 1951, pp. 65-83. (Contract No. N9onr 82100, Task Order No. N9onr 82101, Proj. NR 034-402.)

TABLE I. - SHORT-TIME TENSILE STRENGTH, YIELD STRENGTH, AND DUCTILITY OF MOLYBDENUM

Swaging, percent	Temperature, °F	Ultimate tensile strength, lb/sq in.	Yield strength, 0.2 percent offset, lb/sq in.	Elongation in 1.25 in., percent	Reduction in area, percent	Remarks
99	-148	152,300	-----	5.1	----	-----
99	-102	151,500	-----	3.9	----	-----
99	-100	147,600	-----	4.3	----	-----
99	-71	132,800	-----	7.2	----	-----
99	-60	133,000	-----	7.8	----	-----
99	-32	124,900	-----	11.5	----	-----
99	-30	129,200	-----	10.0	----	-----
99	-3	117,400	-----	14.1	----	-----
99	0	118,500	-----	14.8	----	-----
99	33	115,000	-----	20.5	----	-----
99	33	113,200	-----	16.0	----	-----
99	76	104,900	94,600	26.6	----	-----
99	76	102,200	90,100	25.8	----	-----
99	78	101,800	90,200	25.2	----	-----
99	78	100,800	88,500	26.6	----	-----
99	78	96,000	81,600	28.9	----	-----
99	79	99,200	86,500	20.3	----	-----
99	80	98,700	85,500	26.6	----	-----
99	125	90,000	-----	26.6	----	-----
99	172	83,500	-----	23.4	----	-----
99	228	83,600	-----	24.5	----	-----
99	230	84,800	-----	24.2	----	-----
99	298	77,400	-----	13.8	----	-----
99	302	79,800	-----	22.8	----	-----
99	320	77,400	-----	18.1	----	-----
99	600	65,400	-----	8.2	----	-----
99	900	58,500	-----	8.2	----	-----
99	1200	48,600	-----	8.7	----	-----
99	1800	34,900	-----	8.2	----	-----
99	1800	33,800	-----	11.2	----	-----
99	1800	32,600	-----	10.6	----	-----
99	77	96,700	84,900	25.0	----	(a)
99	77	94,100	80,600	28.1	----	(a)
99	-83	83,600	-----	0	0	(b)
99	0	73,300	-----	0	0	(b)
99	34	72,500	-----	1.2	0	(b)
99	34	71,400	-----	2.4	0	(b)
99	56	83,900	-----	20.0	26.4	(b)
99	56	78,300	-----	6.2	4.4	(b)
99	77	75,400	67,600	29.7	52.3	(c)
99	78	78,600	61,400	32.8	58.9	(c)
99	78	70,900	63,800	3.1	3.2	(c)
99	184	61,700	-----	51.3	71.4	(b)
99	325	51,200	-----	45.0	78.0	(b)
99	400	50,200	-----	44.4	-----	(b)
99	900	35,100	-----	41.8	-----	(b)
99	1500	28,100	-----	36.6	-----	(b)
98.5	76	99,100	86,200	12.5	----	(d)
98.5	77	96,500	86,600	6.3	----	(d)
98.5	78	97,000	85,400	21.9	----	-----
98.5	78	95,600	82,500	18.8	----	(a), (d)
98.5	78	92,800	81,400	9.5	----	(a), (d)
98.5	78	92,600	79,900	31.3	----	(a)
98.5	76	79,700	63,100	27.3	----	(c)
98.5	76	78,400	57,400	25.0	----	(c)
98.5	76	75,100	55,700	20.3	----	(c)
98.5	76	102,000	91,000	17.2	----	-----

<sup>a</sup>Stress relieved (1/2 hr at 1742° F).

<sup>b</sup>Recrystallized (1 hr at 2400° F).

<sup>c</sup>Recrystallized (6 min at 2375° F).

<sup>d</sup>Flaw in test section.

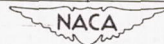

2689

TABLE I. - Concluded. SHORT-TIME TENSILE STRENGTH, YIELD STRENGTH, AND DUCTILITY OF MOLYBDENUM

Swaging, percent	Temperature, °F	Ultimate tensile strength, lb/sq in.	Yield strength, 0.2 percent offset, lb/sq in.	Elongation in 1.25 in., percent	Reduction in area, percent	Remarks
98.1	76	96,000	85,700	21.9	----	
98.1	77	97,400	83,800	27.3	----	
98.1	77	98,100	85,100	21.9	----	(a)
98.1	77	94,900	82,700	23.4	----	(a)
98.1	78	94,700	82,500	23.4	----	(a)
98.1	75	77,500	64,800	6.5	----	(c)
98.1	75	61,400	60,700	0	----	(c)
98.1	76	82,300	65,100	12.5	----	(c)
96.9	77	96,200	86,500	21.9	----	
96.9	77	96,500	-----	22.7	----	
96.9	78	96,000	85,700	22.3	----	
96.9	76	95,700	87,300	25.0	----	(a)
96.9	76	94,500	84,800	25.0	----	(a)
96.9	76	92,500	81,900	28.1	----	(a)
50	-111	131,500	-----	0	----	-----
50	-60	120,800	-----	2.5	----	-----
50	-6	110,900	-----	2.5	----	-----
50	-4	109,800	-----	0	----	-----
50	35	102,500	-----	2.5	----	-----
50	56	100,700	-----	17.8	----	-----
50	78	94,000	83,100	21.9	----	-----
50	79	95,100	83,400	25.8	----	-----
50	79	94,300	81,000	24.2	----	-----
50	127	87,300	-----	26.5	----	-----
50	169	79,300	-----	26.5	----	-----
50	1800	33,100	-----	13.3	----	-----
50	1800	32,100	-----	7.5	----	-----
50	1800	29,600	-----	8.7	----	-----
50	78	91,800	80,400	28.5	----	(a)
50	78	91,500	83,300	29.7	----	(a)
50	-95	68,100	-----	0	0	(e)
50	-8	83,700	-----	2.4	4.3	(e)
50	34	74,000	-----	3.7	2.1	(e)
50	80	72,700	44,400	12.7	9.6	(f)
50	80	71,400	41,700	13.3	13.8	(f)
50	130	66,200	-----	22.8	22.6	(e)
50	201	57,700	-----	23.5	35.5	(e)
35	-105	101,800	-----	0	----	-----
35	-62	97,800	-----	0	----	-----
35	-4	102,100	-----	0	----	-----
35	35	94,800	-----	0	----	-----
35	57	95,700	-----	3.1	----	-----
35	79	91,800	79,600	7.1	----	-----
35	79	88,700	80,600	8.6	----	-----
35	79	88,300	76,300	3.1	----	-----
35	125	82,000	-----	18.5	----	-----
35	170	73,900	-----	23.4	----	-----
35	1800	34,900	-----	10.0	----	-----
35	1800	34,600	-----	8.7	----	-----
35	1800	31,500	-----	10.0	----	-----
35	78	88,600	80,600	31.3	----	(a)
35	78	86,300	78,600	29.7	----	(a)
35	34	71,400	-----	3.1	4.4	(e)
35	80	70,700	40,700	11.7	8.9	(f)
35	80	69,900	41,500	11.7	9.6	(f)
35	127	63,700	-----	9.4	6.4	(e)
35	162	59,400	-----	10.8	9.6	(e)
35	205	52,100	-----	21.9	31.3	(e)

<sup>a</sup>Stress relieved (1/2 hr at 1742° F).

<sup>c</sup>Recrystallized (6 min at 2375° F).

<sup>e</sup>Recrystallized (1 hr at 2700° F).

<sup>f</sup>Recrystallized (2 hr at 2642° F).

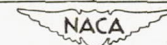

2689

TABLE II. - ANALYSIS OF MOLYBDENUM

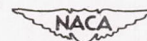

Element	Percent by weight	Accuracy	Method of analysis
Oxygen	0.0022	+0.0002	(a)
Hydrogen	.00002	+0.00002	(a)
Nitrogen	.0002	+0.0002	(a)
Carbon	.004	+0.001	(b)
Sulfur	.003	+0.001	(b)
Boron	.005		(c)
Phosphorous	.05		(c)
Iron	.01		(c)
Magnesium	.05		(c)
Lead	.005		(c)
Silicon	.05		(c)
Bismuth	.01		(c)
Chromium	.005		(c)
Aluminum	.01		(c)
Uranium	.10		(c)
Columbium	.05		(c)
Vanadium	.05		(c)
Copper	.01		(c)
Zinc	.05		(c)
Titanium	.05		(c)
Cobalt	.05		(c)
Nickel	.01		(c)
Calcium	.005		(c)
Manganese	.005 <sup>d</sup>		(c)
Antimony	.005 <sup>d</sup>		(c)
Arsenic	.005 <sup>d</sup>		(c)
Barium	.01 <sup>d</sup>		(c)
Lithium	.005 <sup>d</sup>		(c)
Cadmium	.01 <sup>d</sup>		(c)
Silver	.005 <sup>d</sup>		(c)

<sup>a</sup>Vacuum fusion.

<sup>b</sup>Conventional chemical.

<sup>c</sup>Semiquantitative spectrographic.

<sup>d</sup>Not measurable (values represent detectable limit).

TABLE III. - TRANSITION TEMPERATURE RANGE OF MOLYBDENUM

Swaging, percent	As-swaged transition temperature range, °F	Recrystallized metal transition temperature range, °F	Average change from as-swaged to recrystallized, °F
99	-50 - 20	65 - 80	+87
50	20 - 45	50 - 85	+35
35	80 - 110	60 - 105	-13

2689

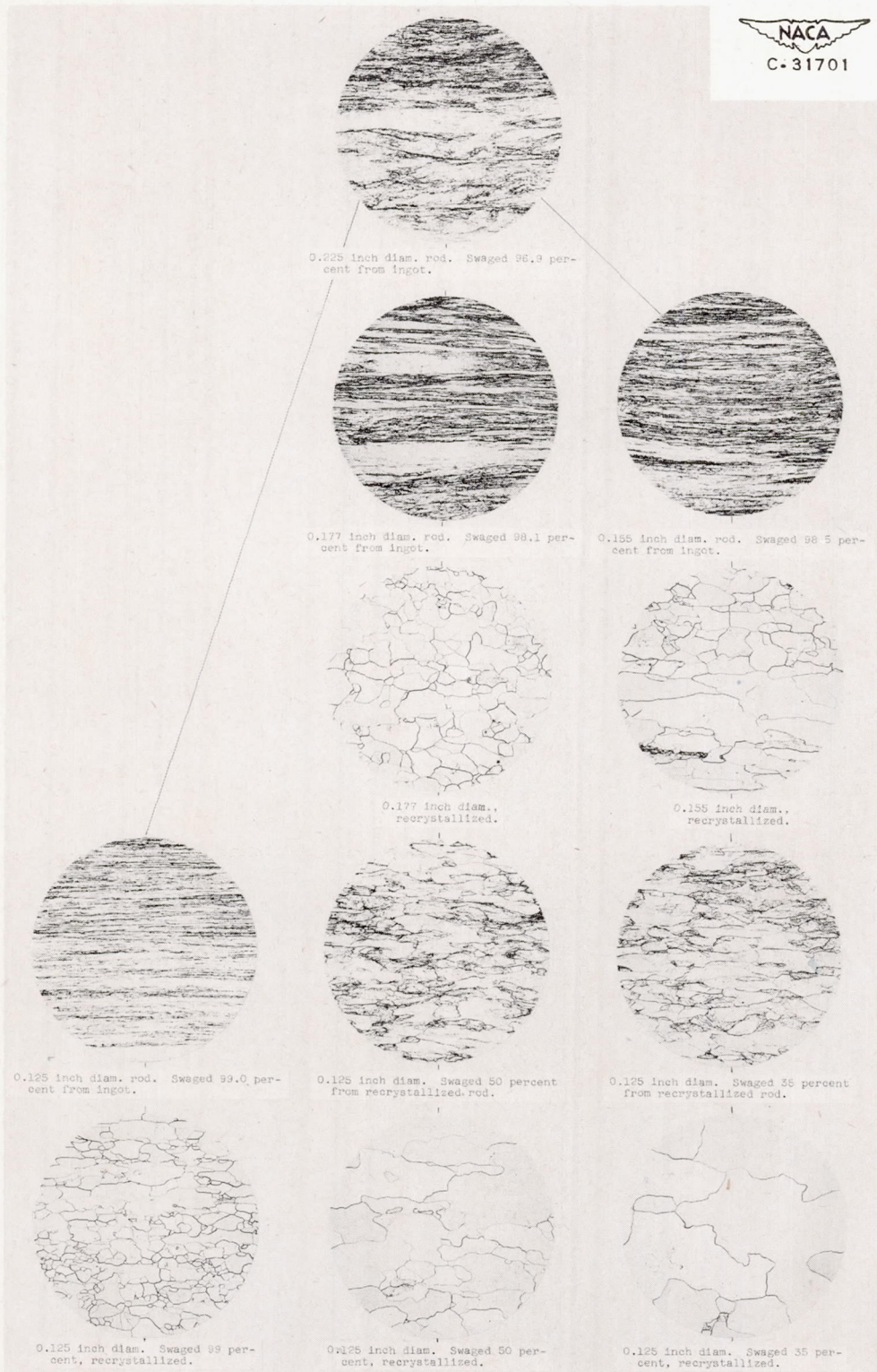
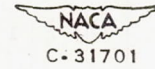

Figure 1. - Longitudinal views of microstructure changes from controlled swaging. Photographed at X100, reduced 40 percent in reproduction.

2689



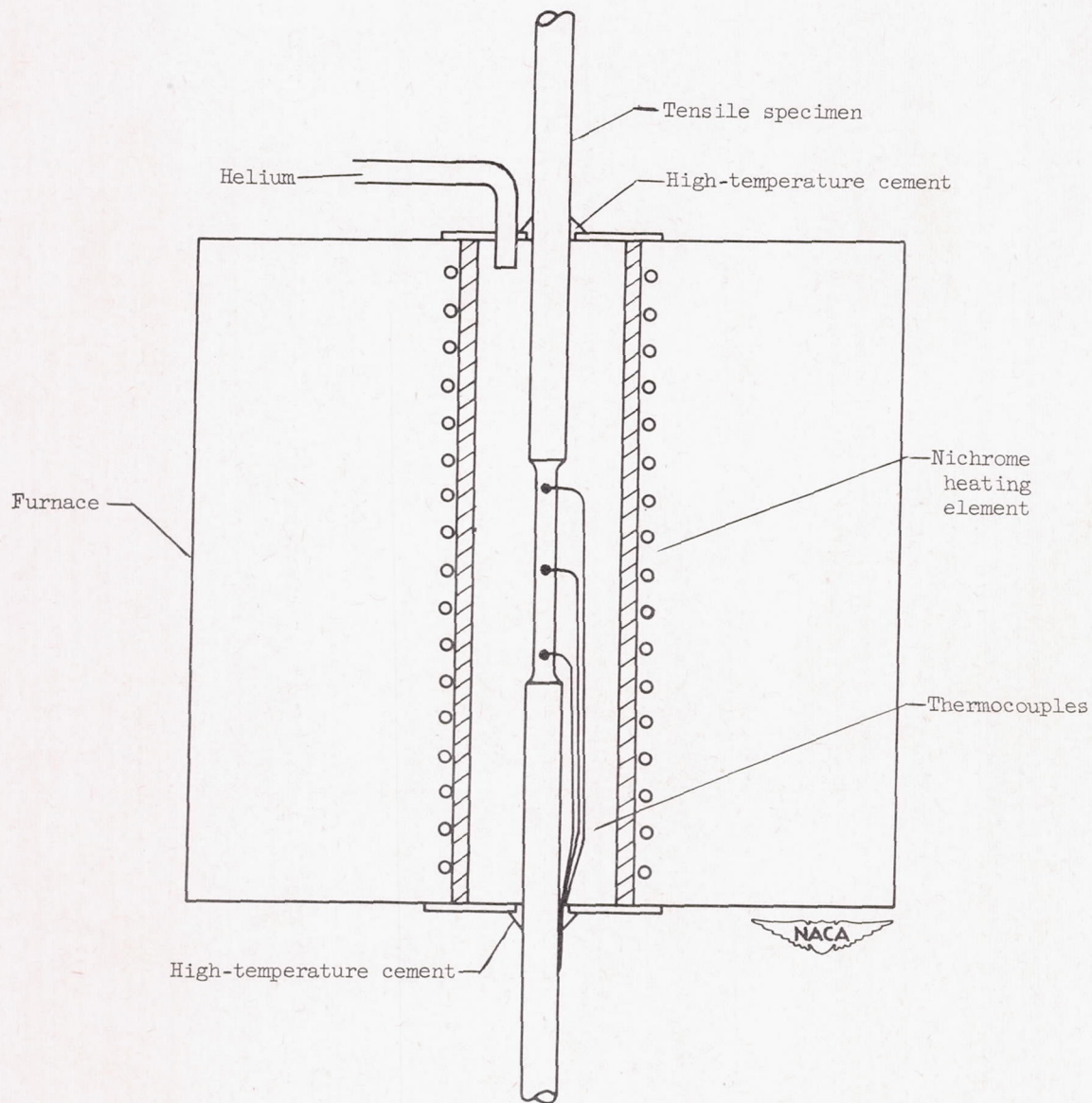

Figure 2. - Apparatus for high-temperature tensile tests.

2689

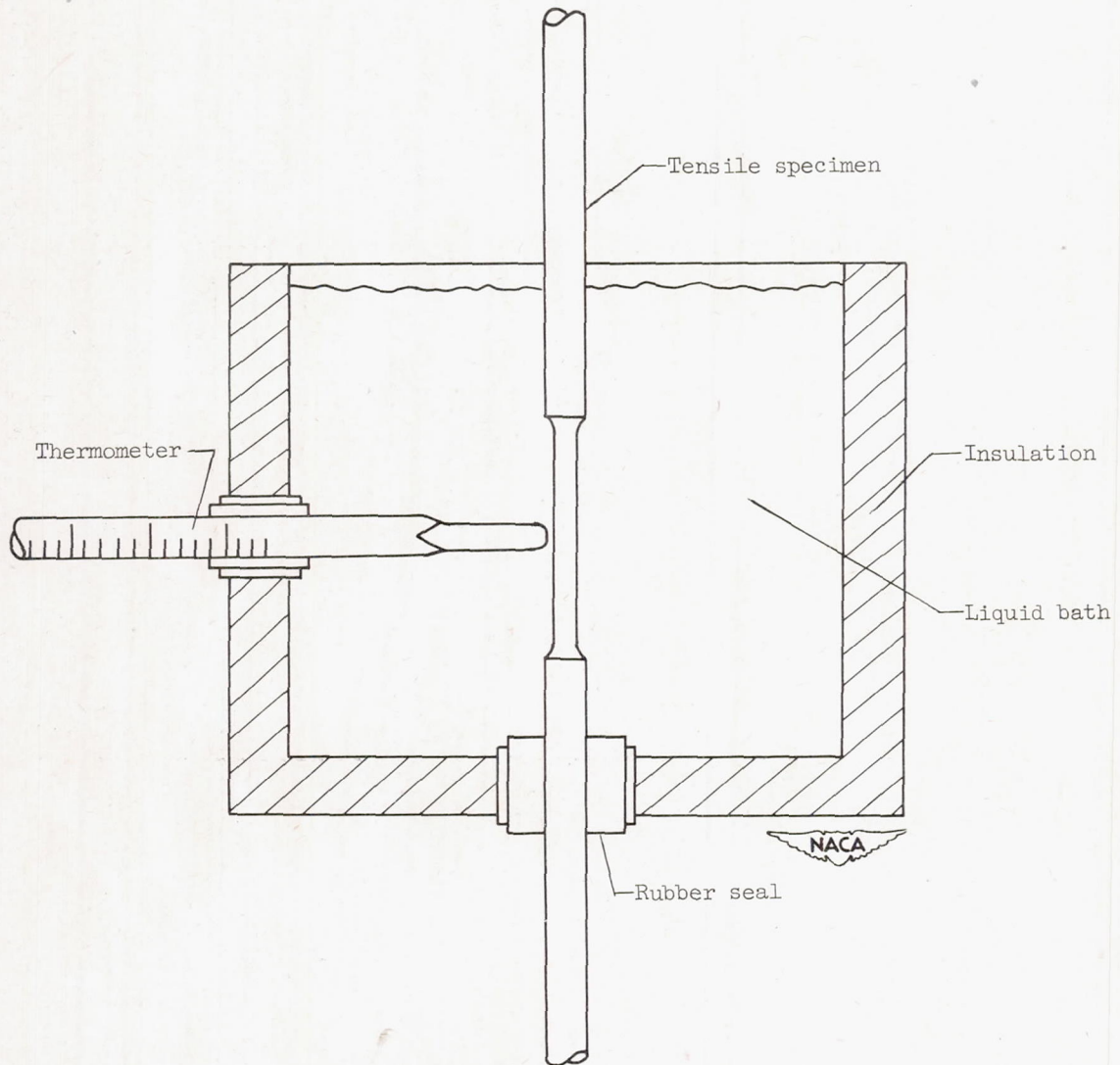

Figure 3. - Liquid bath for tensile tests.

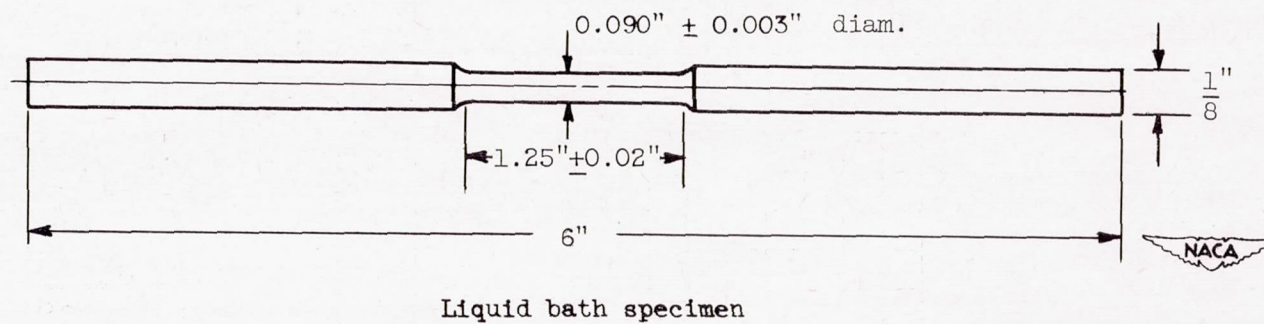
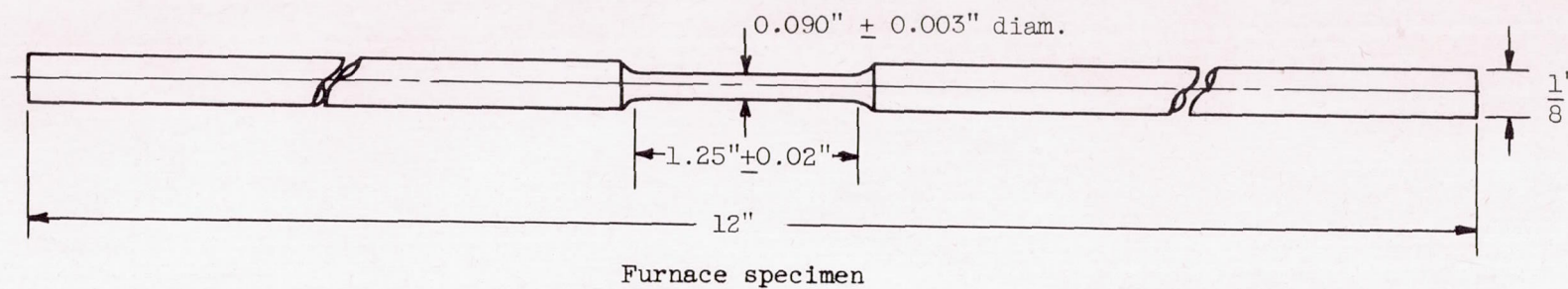

Figure 4. - Tensile specimens.

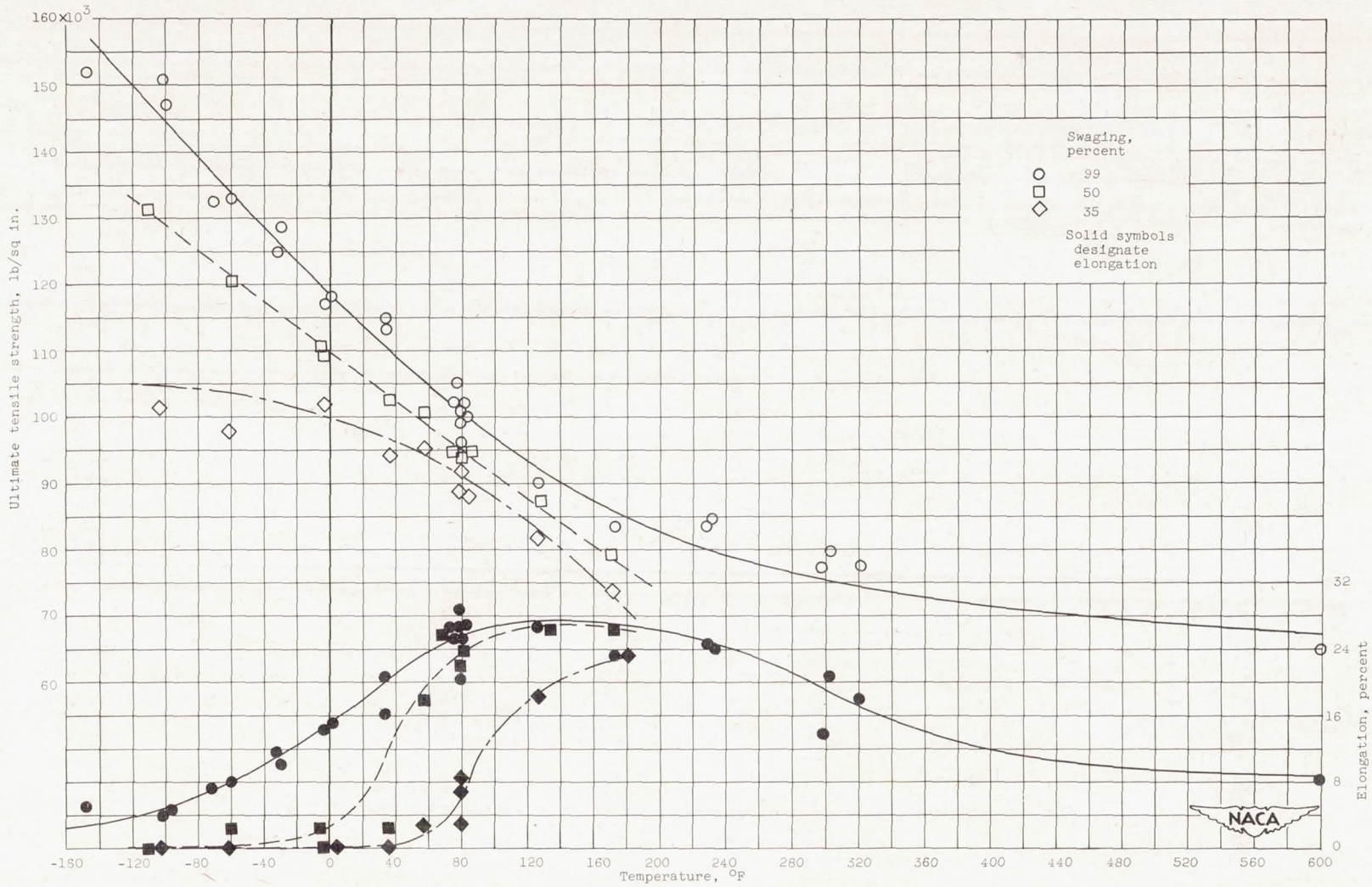

Figure 5. - Change of transition temperature and strength of molybdenum with swaging.

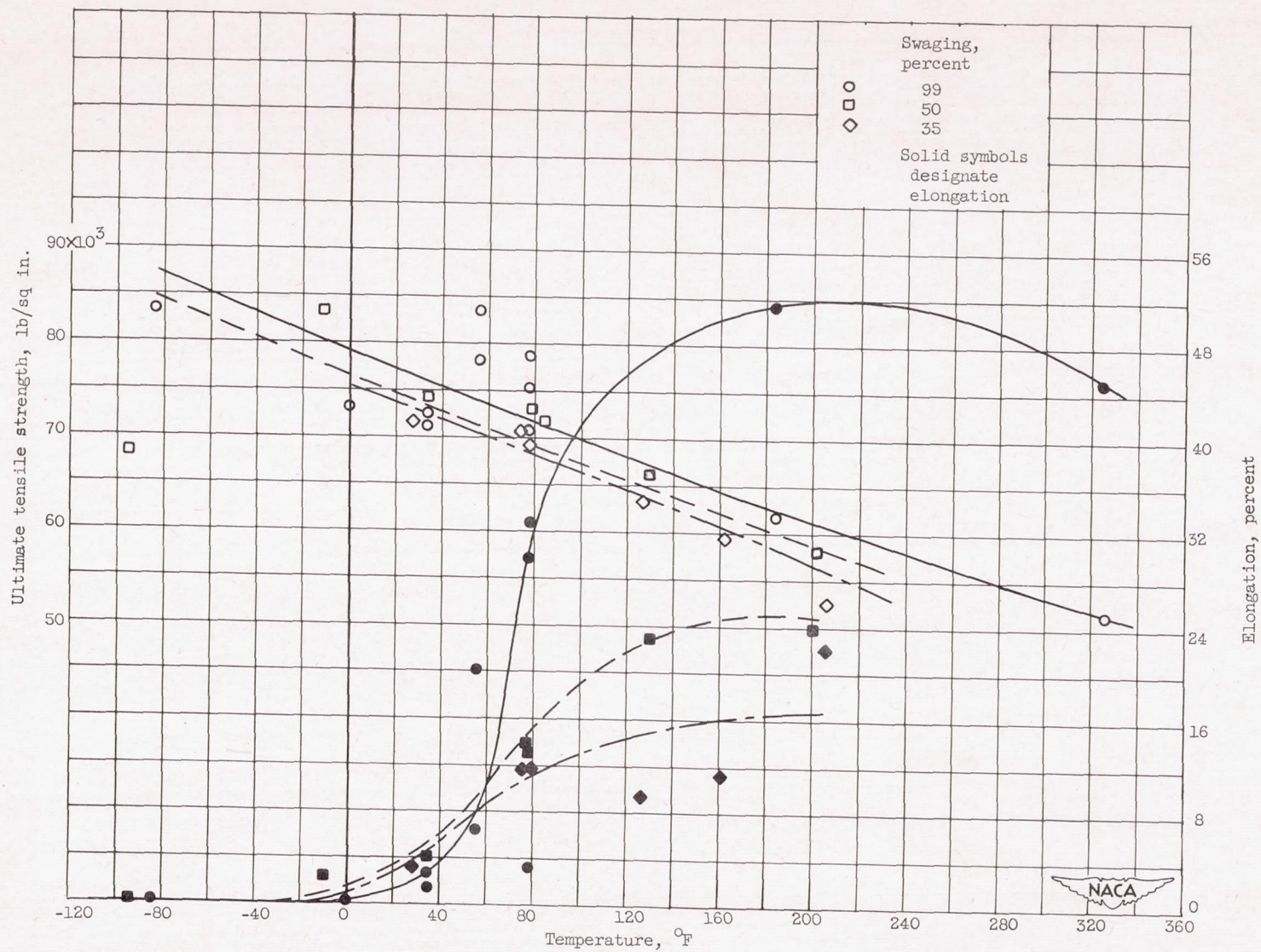

Figure 6. - Change of transition temperature and strength of molybdenum recrystallized after final swaging.

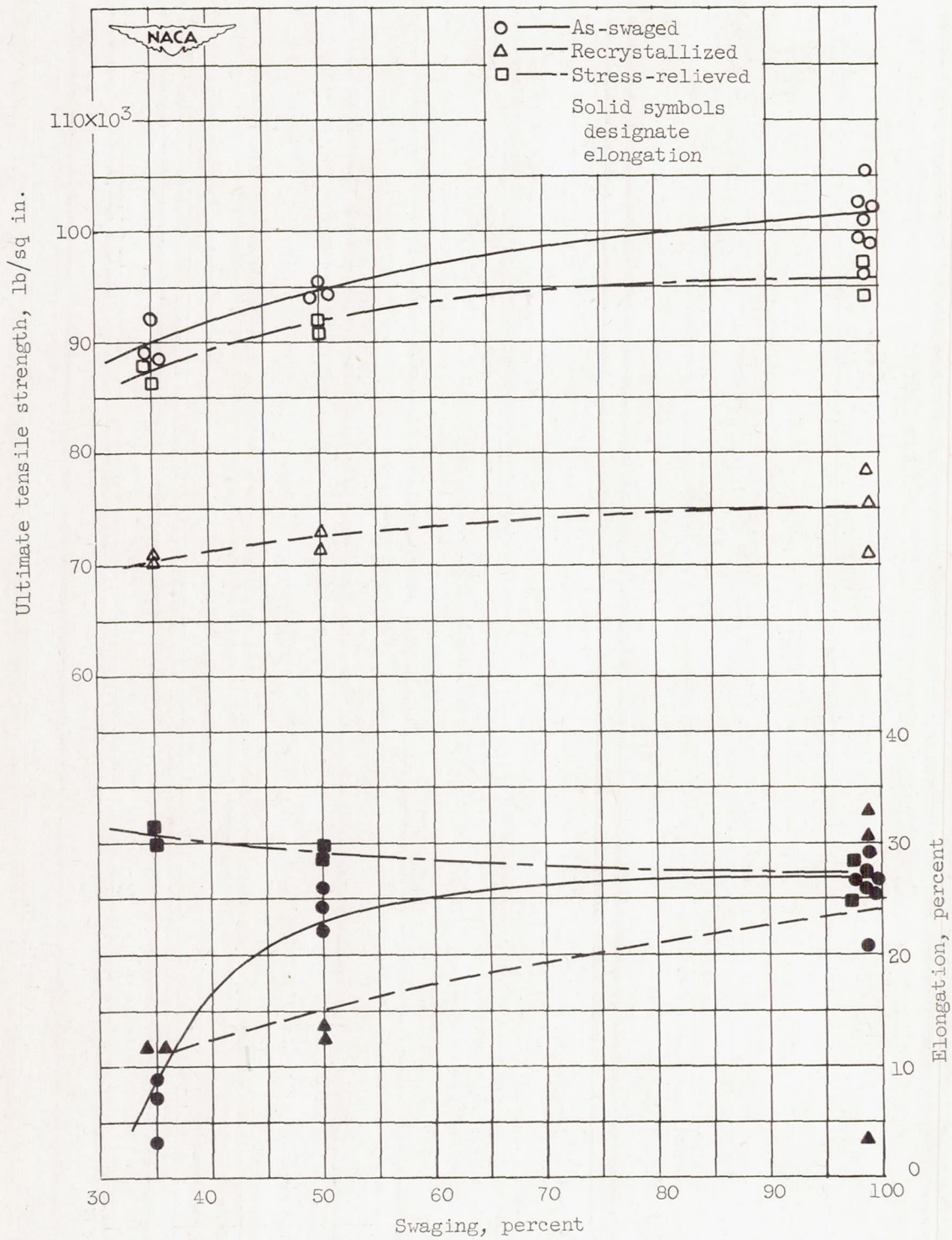
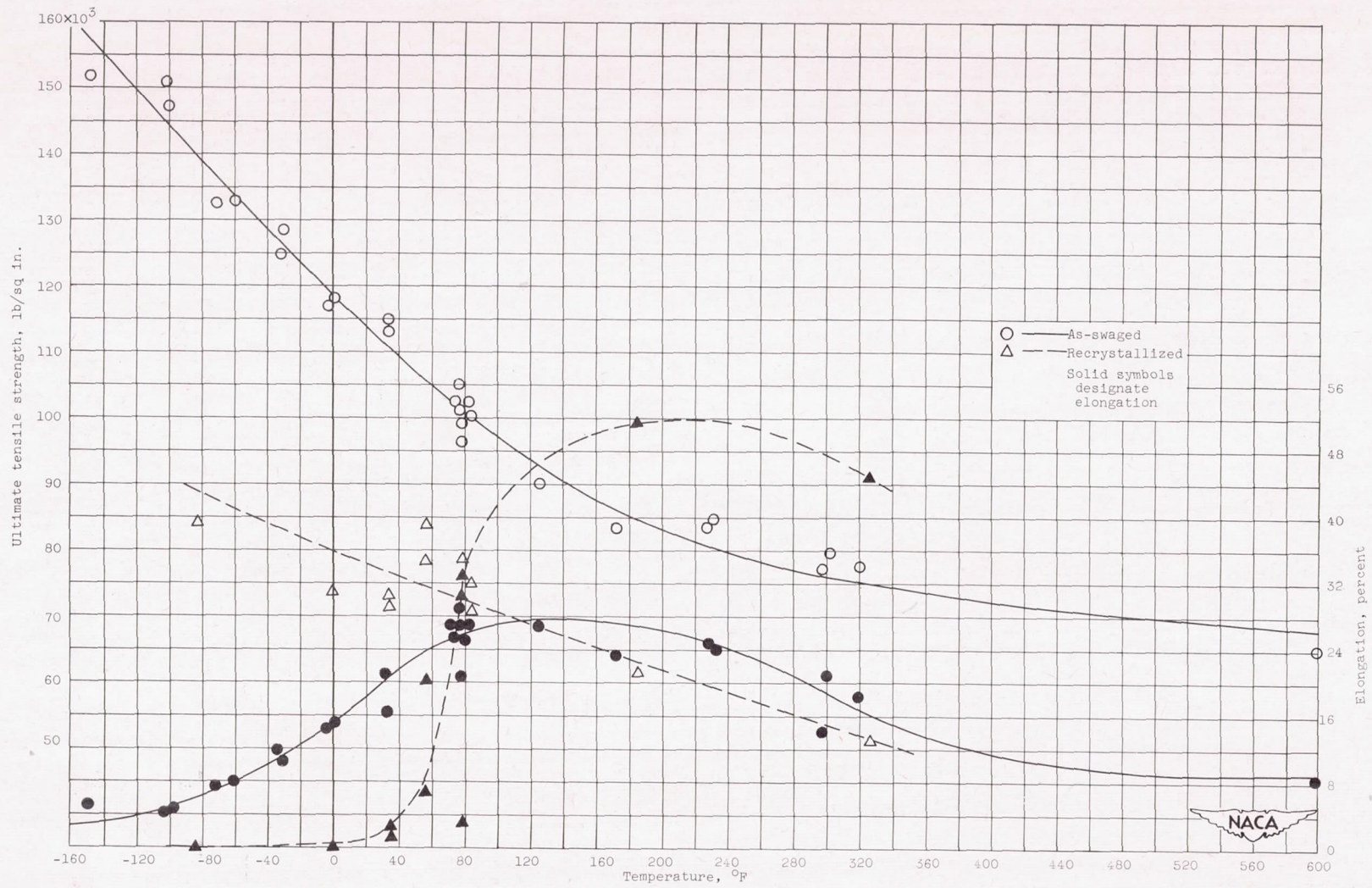
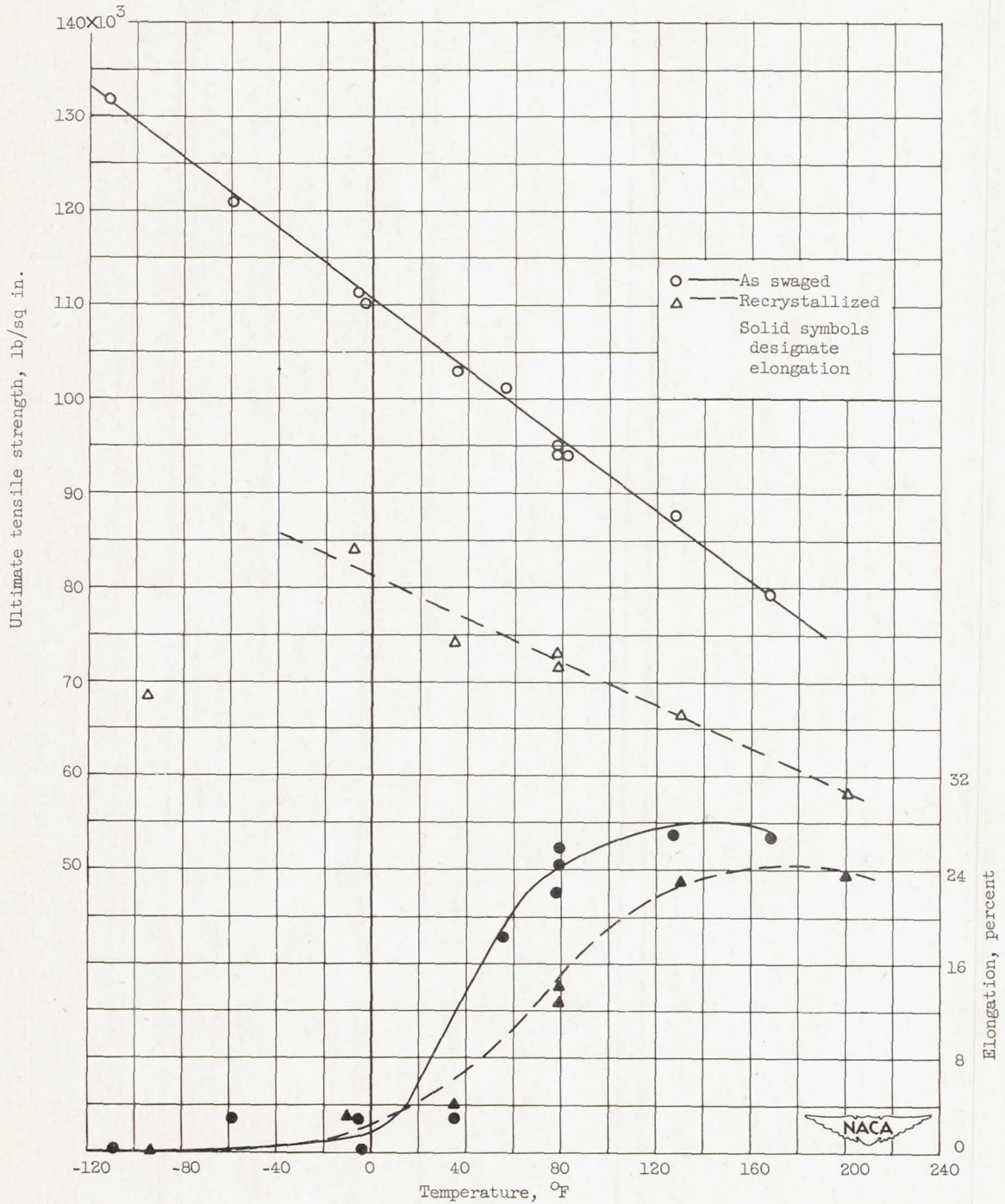

Figure 7. - Effect of swaging and subsequent treatments on strength and ductility of molybdenum at room temperature.



(a) Swaged 99 percent.

Figure 8. - Change of properties of molybdenum with temperature for three amounts of swaging.



(b) Swaged 50 percent.

Figure 8. - Continued. Change of properties of molybdenum with temperature for three amounts of swaging.





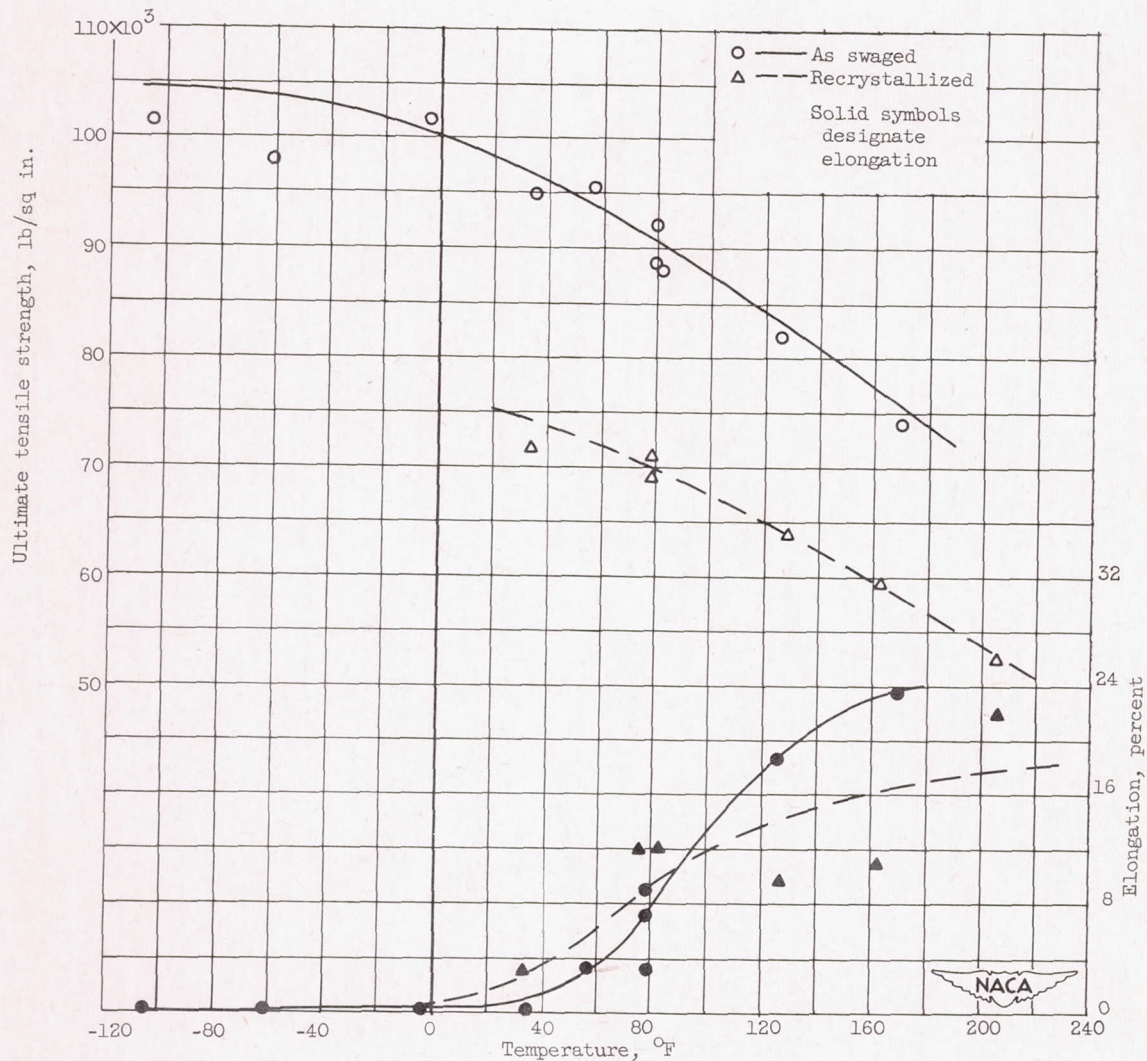

(c) Swaged 35 percent.

Figure 8. - Concluded. Change of properties of molybdenum with temperature for three amounts of swaging.

2689



(a) As-swaged; fractured at  $-100^{\circ}$  F; 4.3 percent elongation.

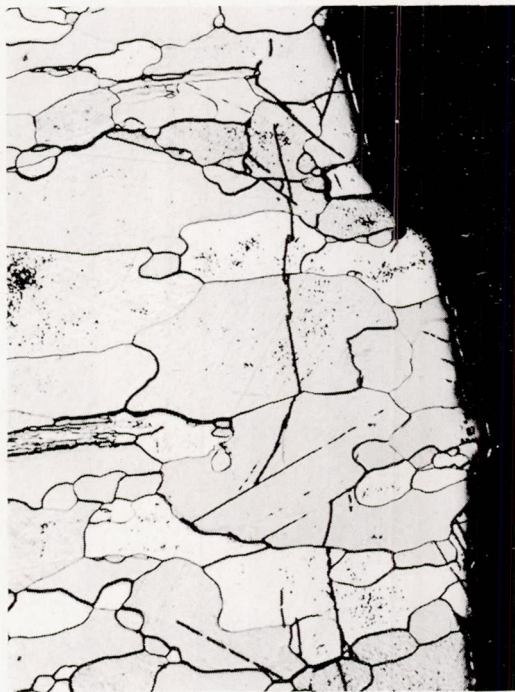

(b) Recrystallized; fractured at  $-83^{\circ}$  F; no elongation.

Figure 9. - Fractures below transition temperature range of molybdenum swaged 99 percent as shown by longitudinal views. X150.

NACA  
C-31702

2689

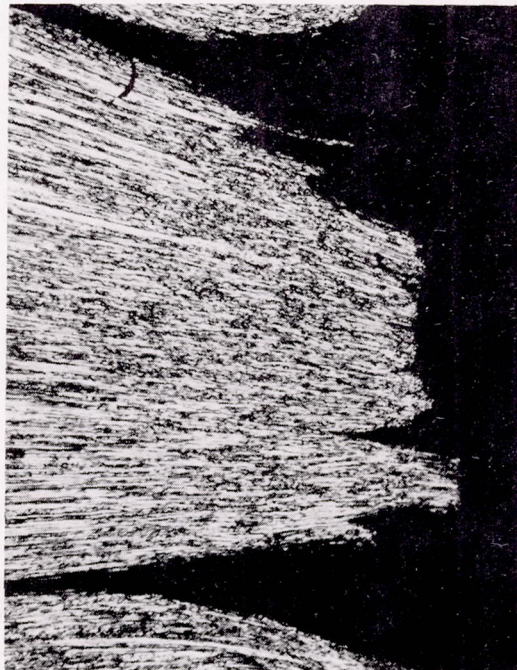

(a) As-swaged; fractured at 320° F; 18.1 percent elongation.



(b) Recrystallized; fractured at 325° F; 45 percent elongation.

NACA  
C-31703

Figure 10. - Fractures above transition temperature range of molybdenum swaged 99 percent as shown by longitudinal views. X150.

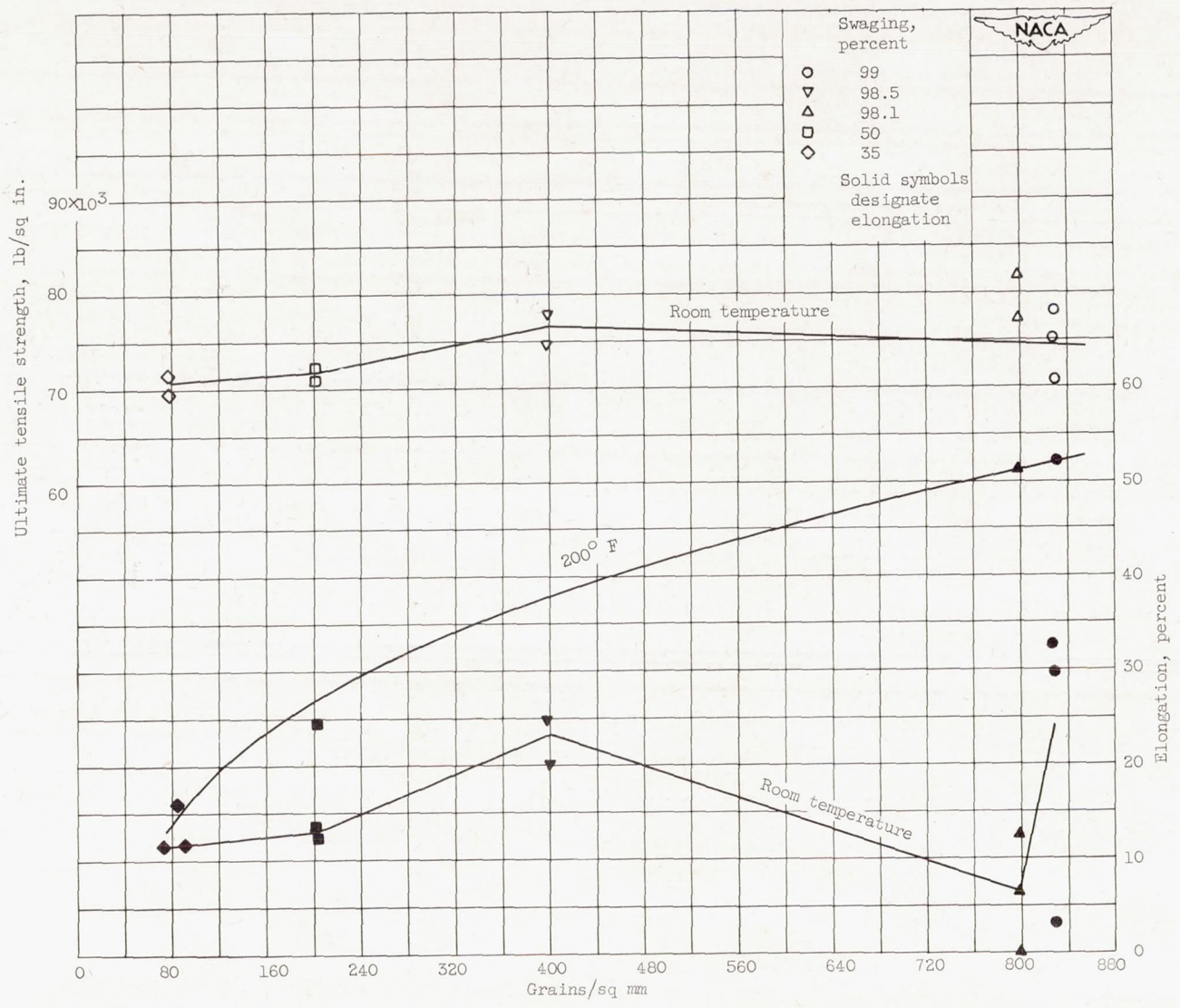

Figure 11. - Relation of grain size to strength and ductility of recrystallized molybdenum.