

85

NACA TN 2972

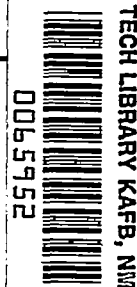

NATIONAL ADVISORY COMMITTEE FOR AERONAUTICS

TECHNICAL NOTE 2972

THEORETICAL PRESSURE DISTRIBUTIONS AND WAVE DRAGS
FOR CONICAL BOATTAILS

By John R. Jack

Lewis Flight Propulsion Laboratory
Cleveland, Ohio



Washington

July 1953

TECHNICAL

AUG 1953



NATIONAL ADVISORY COMMITTEE FOR AERONAUTICS

TECHNICAL NOTE 2972

THEORETICAL PRESSURE DISTRIBUTIONS AND WAVE DRAGS

FOR CONICAL BOATTAILS

By John R. Jack

SUMMARY

Afterbody pressure distributions and wave drags were calculated using a second-order theory for a variety of conical boattails at zero angle of attack. Results are presented for Mach numbers from 1.5 to 4.5, area ratios from 0.200 to 0.800, and boattail angles from 3° to 11° .

The results indicate that for a given boattail angle, the wave drag decreases with increasing Mach number and area ratio. The wave drag, for a constant area ratio, increases with increasing boattail angle. For a specific Mach number, area ratio, and fineness ratio, a comparison of the wave-drag coefficients for conical, tangent-parabolic, and secant-parabolic boattails showed the conical boattail to have the smallest wave drag.

INTRODUCTION

One of the major components of a missile configuration is the afterbody section known as the boattail. There are, however, little data available to serve either as a guide in the design of boattails for supersonic bodies or as a basis for estimating the aerodynamic loads and wave drags associated with boattails. It has generally been assumed that boundary layer effects render the potential flow computations toward the rear of the missile meaningless. However, available experimental data indicate that potential theory does predict the boattail characteristics adequately for most design purposes. An investigation was therefore undertaken at the NACA Lewis laboratory to study systematically the variations of pressure distributions and wave drags of conical boattails with Mach number, area ratio, and boattail angle¹.

¹After completion of the work presented in this report, a report of similar content came to the attention of the author (ref. 1). However, since reference 1 does not present any pressure distributions, which are quite valuable for structural designs and for estimating base pressures, publication of the present report was considered warranted.

Pressure distributions and wave-drag coefficients are presented for Mach numbers from 1.5 to 4.5, area ratios from 0.200 to 0.800, and boattail angles from 3° to 11° .

METHOD OF COMPUTATION

Pressure distributions for each boattail were calculated using the second-order theory developed in reference 2. It was assumed that the boattails are preceded by a cylindrical section of sufficient length to give uniform flow at the free-stream Mach number at the beginning of each boattail. The calculating procedure followed was that presented in reference 3, in which the approximate boundary condition at the surface of the body is used to obtain the perturbation velocities, and the exact isentropic pressure relation is used for evaluating the pressure coefficient at each point on the body. In each case the solution was carried downstream to the point at which the radius of the Mach cone from the beginning of the boattail has grown to ten times the local radius of the boattail. As indicated in reference 2, the second-order solution could be carried beyond this point by extending the tables used in the computations; however, the area ratios of practical interest correspond to boattail lengths which, in general, are within this limitation. The procedure presented in reference 3 proves to be an expedient means of obtaining both a first- and a second-order solution. The average time for calculating the combined first- and second-order solutions was approximately 11 computer hours.

Wave-drag coefficients for each boattail were obtained by graphically integrating the pressure distributions over the boattail surfaces. The wave-drag coefficient was based on the maximum area of the boattail and is defined by

$$C_D = \int_1^{\frac{R}{R_m}} C_p d \left(\frac{r}{R_m} \right)^2$$

where C_p is the exact isentropic pressure coefficient, r is the local boattail radius, and R_m and R are the maximum and minimum boattail radii, respectively.

RESULTS AND DISCUSSION

Pressure distributions and wave drags. - The variations of pressure coefficient in the axial direction for the conical boattails are presented in figure 1 for selected values of boattail angle and free-stream

Mach number. In each case, the pressure coefficient has approximately the Prandtl-Meyer value at the beginning of the boattail because of the expansive turning through the boattail angle, which is followed by a continuous compression along the boattail surface. The pressure coefficient level increases with increasing Mach number for a given boattail angle and, for a given Mach number, decreases as the boattail angle increases.

The dependence of the pressure distributions upon fineness ratio and area ratio may be found by correlating boattail angle with fineness ratio and area ratio. The variation of fineness ratio and area ratio with boattail angle is given in figure 2.

Graphical integration of the pressure distributions presented in figure 1 over the boattail surfaces yields the variation of wave-drag coefficient with area ratio and with boattail angle (figs. 3 and 4, respectively). The dashed lines presented in figure 3 represent the limiting area ratio to which the theory of reference 3 can be applied without extending the tables used in the computations. The wave drag coefficients presented in figure 4 were obtained by extrapolating some of the data of figures 3(a) and 3(b). For a given Mach number, the coefficient of wave drag increases with increasing boattail angle and decreases with increasing area ratio.

To extend the Mach number range investigated, the wave-drag coefficient has been plotted as a function of the reciprocal of the Mach number (fig. 5). The results of the present calculations were extrapolated to $1/M_0 = 0$ by using the concepts of Newtonian flow theory which predict a zero drag coefficient for all boattail angles as $M_0 \rightarrow \infty$ (ref. 4). For a specific boattail angle, the coefficient of wave drag decreases as the Mach number is increased.

Body contour effect. - To obtain the effect of body contour on pressure distributions and wave drags, a tangent- and a secant-parabolic boattail contour each having the same length and area ratio have been investigated and the results compared with those obtained from the corresponding inscribed conical boattail. Design parameters for these boattails were arbitrarily chosen and are:

Mach number, M_0	2.5
Fineness ratio, L/D_m	2.255
Area ratio, A/A_m200
Secant-parabolic boattail leading-edge angle, deg	3.5
Conical boattail angle, θ , deg	7

The contours considered for the comparison are alike inasmuch as they are members of the parabolic family, with each having a different expansion angle at the leading edge of the boattail. Defining equations for these boattail contours are as follows:

CU-1 back 0062

Tangent-parabolic:

$$\frac{r}{R_m} = 1 - 0.02719 \left(\frac{x}{R_m} \right)^2$$

Secant-parabolic:

$$\frac{r}{R_m} = 1 - 0.06116 \frac{x}{R_m} - 0.01364 \left(\frac{x}{R_m} \right)^2$$

Conical:

$$\frac{r}{R_m} = 1 - 0.1228 \frac{x}{R_m}$$

Pressure distributions for the tangent- and secant-parabolic boattails are compared with the pressure distribution for the conical boattail in figure 6. Graphical integration of these pressure distributions to obtain the respective wave drags shows the conical boattail to have the least wave drag ($C_D = 0.0465$). The tangent-parabolic boattail has a drag 1.27 times the conical boattail drag; while the secant-parabolic boattail drag is 1.02 times as large.

SUMMARY OF RESULTS

Afterbody pressure distributions and wave drags have been calculated using a second-order theory for various conical boattails at zero angle of attack. The following conclusions have been reached after analyzing the results for a Mach number range from 1.5 to 4.5 and for boattail angles from 3° to 11° :

1. For a given boattail angle, the pressure coefficient level increased with increasing Mach number and for a given Mach number decreased as the boattail angle increased.
2. The wave-drag coefficient for a given boattail angle decreased with increasing Mach number and area ratio. For a given area ratio and increasing boattail angle, the boattail wave-drag coefficient increased.
3. For a Mach number of 2.5, an area ratio of 0.200, and a fineness ratio of 2.25, a comparison of the wave drags for a conical, a tangent-parabolic, and a secant-parabolic boattail shows the conical boattail to have the smallest wave drag.

Lewis Flight Propulsion Laboratory
National Advisory Committee for Aeronautics
Cleveland, Ohio, April 28, 1953

REFERENCES

1. Huth, J. H., and Dye, H. M.: Axial and Normal Force Coefficients for Pointed Bodies of Revolution at Super- and Hypersonic Speeds. Part II - Boattails. RM-905, U. S. Air Force Proj. RAND, The RAND Corp., Aug. 5, 1952.
2. Van Dyke, Milton D.: First- and Second-Order Theory of Supersonic Flow Past Bodies of Revolution. Jour. Aero. Sci., vol. 18, no. 3, Mar. 1951, pp. 161-178.
3. Van Dyke, Milton D.: Practical Calculation of Second-Order Supersonic Flow Past Nonlifting Bodies of Revolution. NACA TN 2744, 1952.
4. Grimminger, G., Williams, E. P., and Young, G. B. W.: Lift on Inclined Bodies of Revolution in Hypersonic Flow. Jour. Aero. Sci., vol. 17, no. 11, Nov. 1950, pp. 675-690.

2900

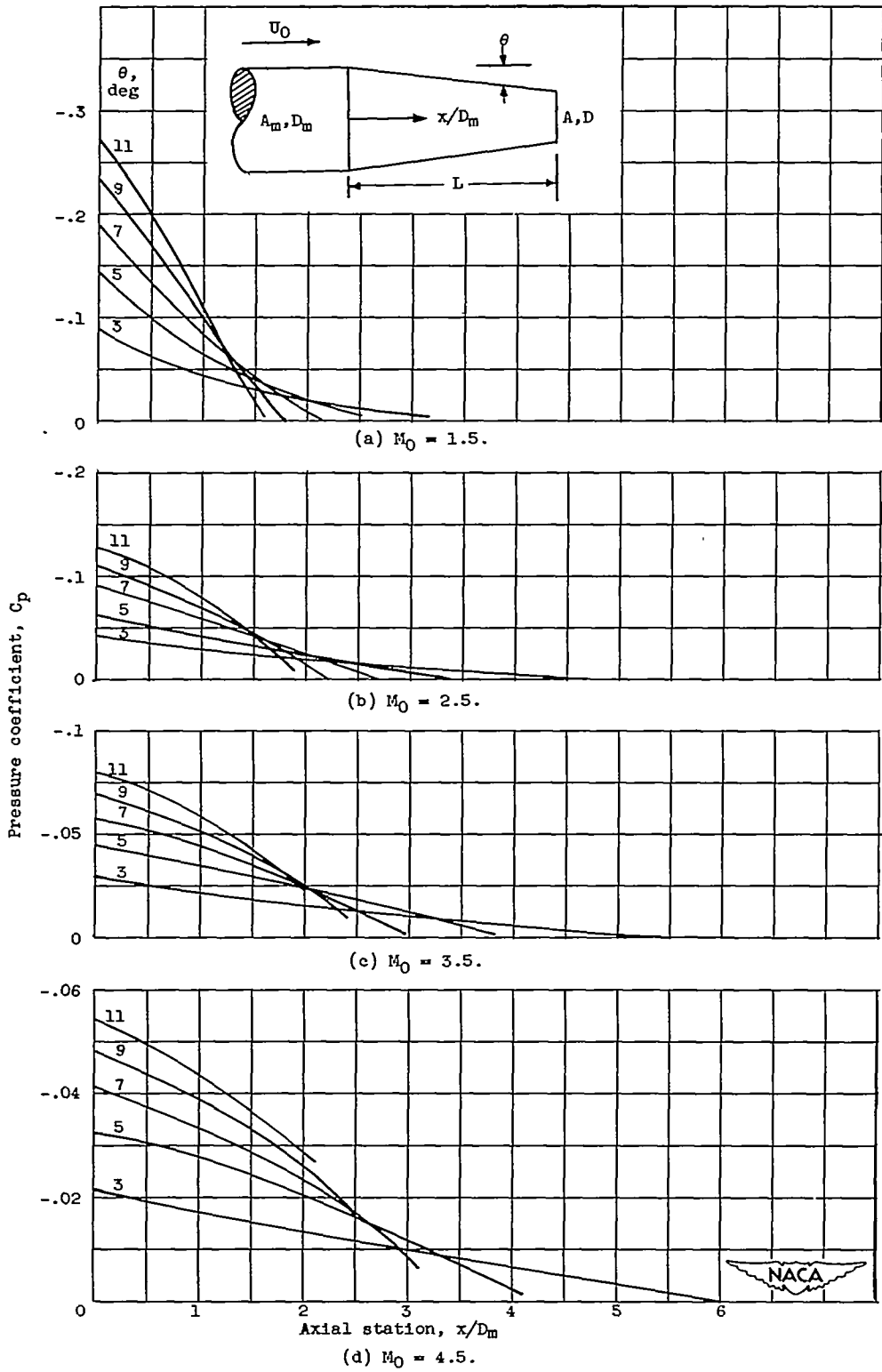

Figure 1. - Variation of pressure coefficient in axial direction for conical boattails.

2900

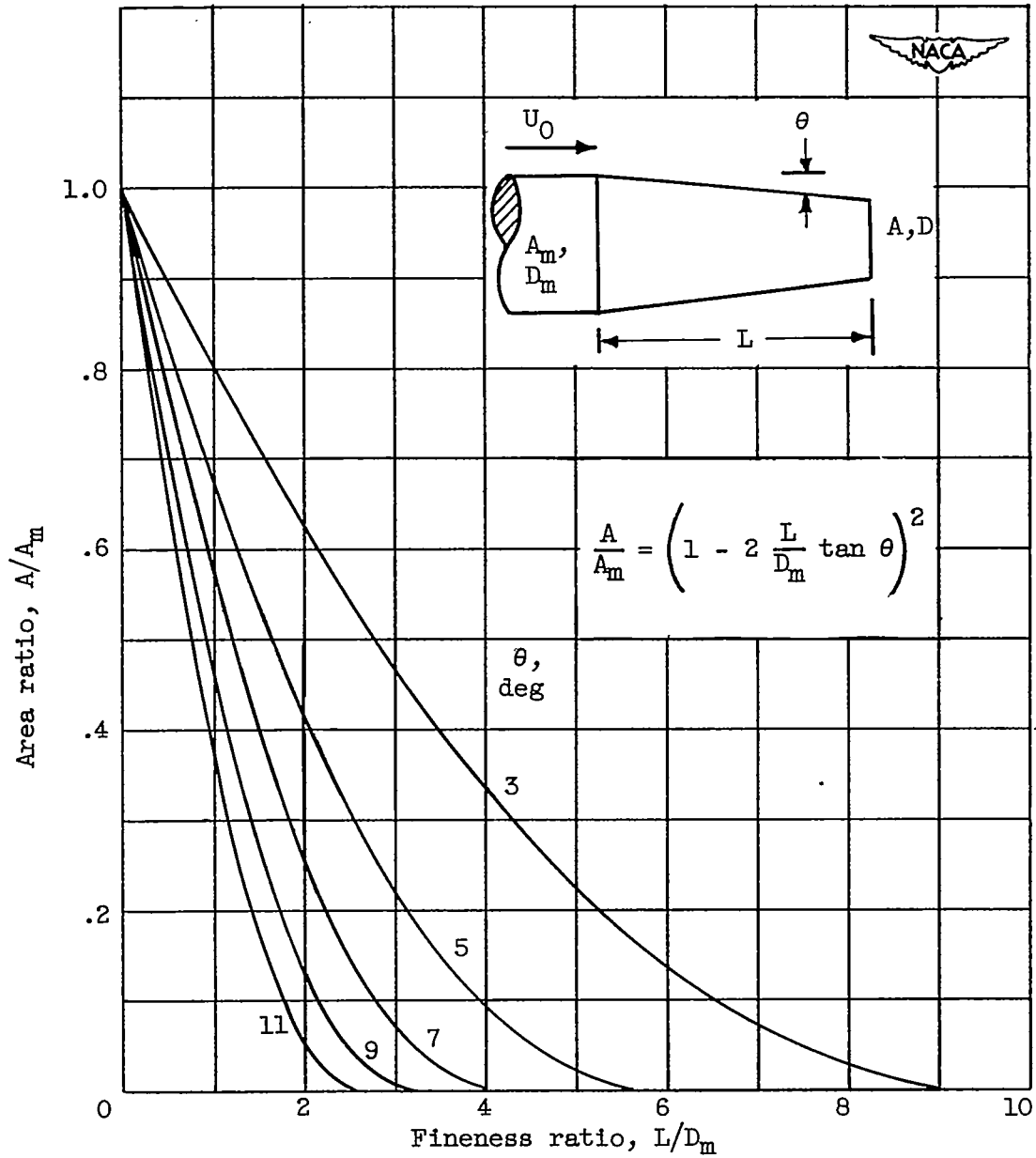
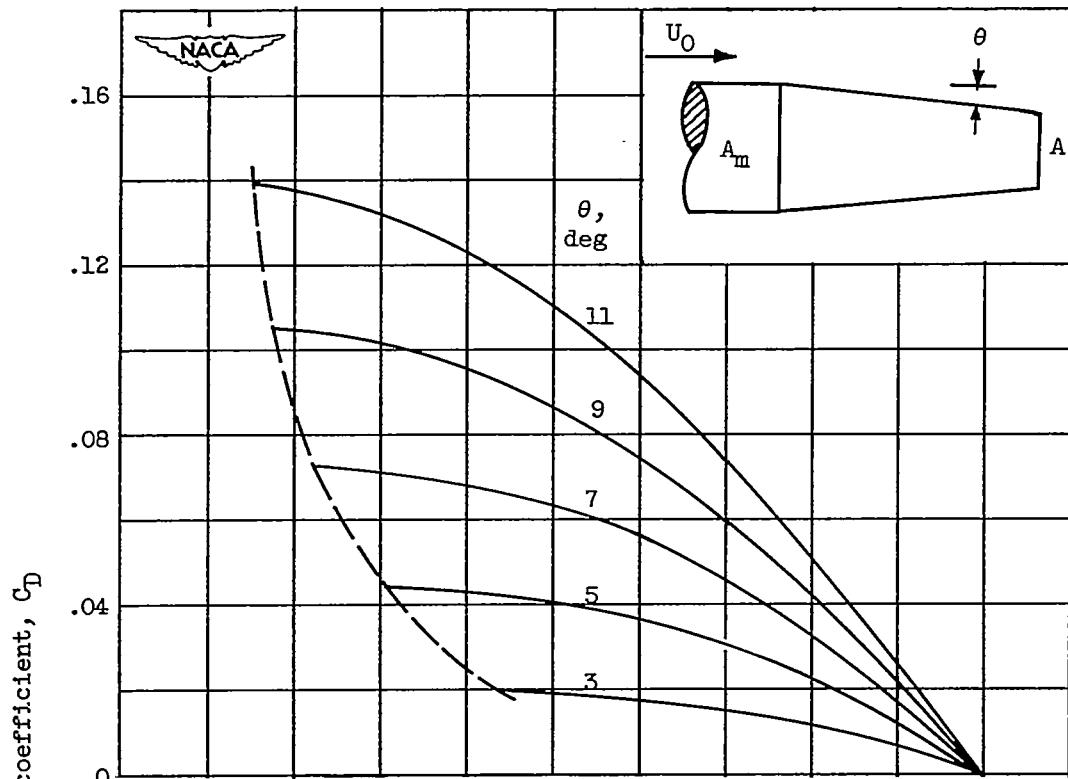
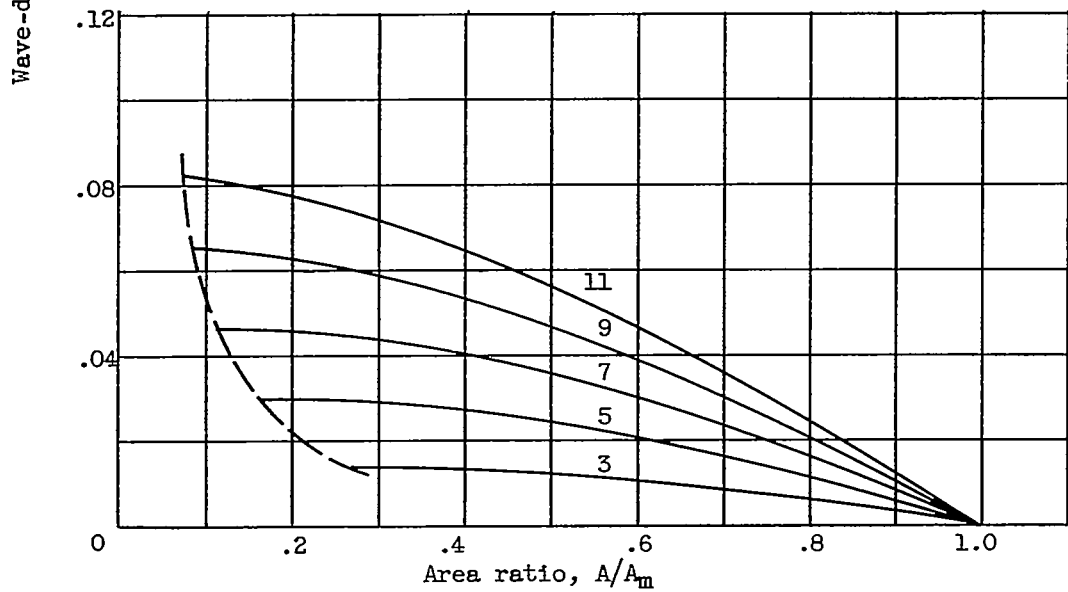

Figure 2. - Relations between boattail angle, area ratio, and fineness ratio.



(a) Mach number, 1.5.



(b) Mach number, 2.5.

Figure 3. - Variation of wave-drag coefficient with area ratio. (Dashed lines represent limiting area ratio for theory of ref. 3.)

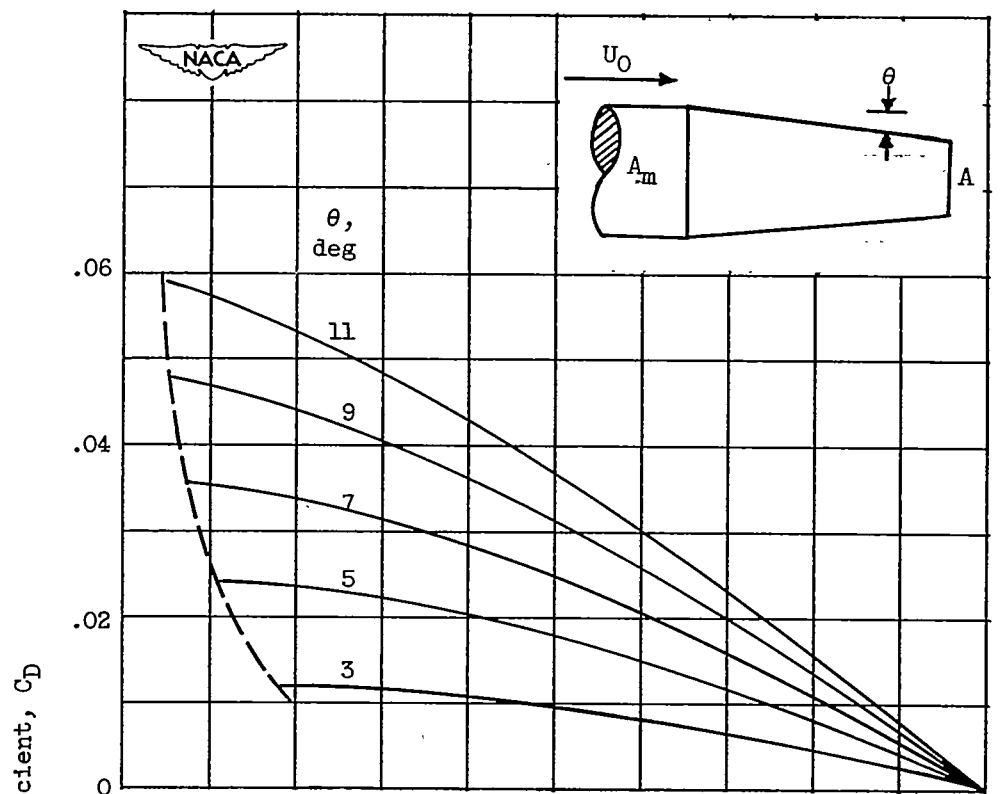

(c) Mach number, 3.5.

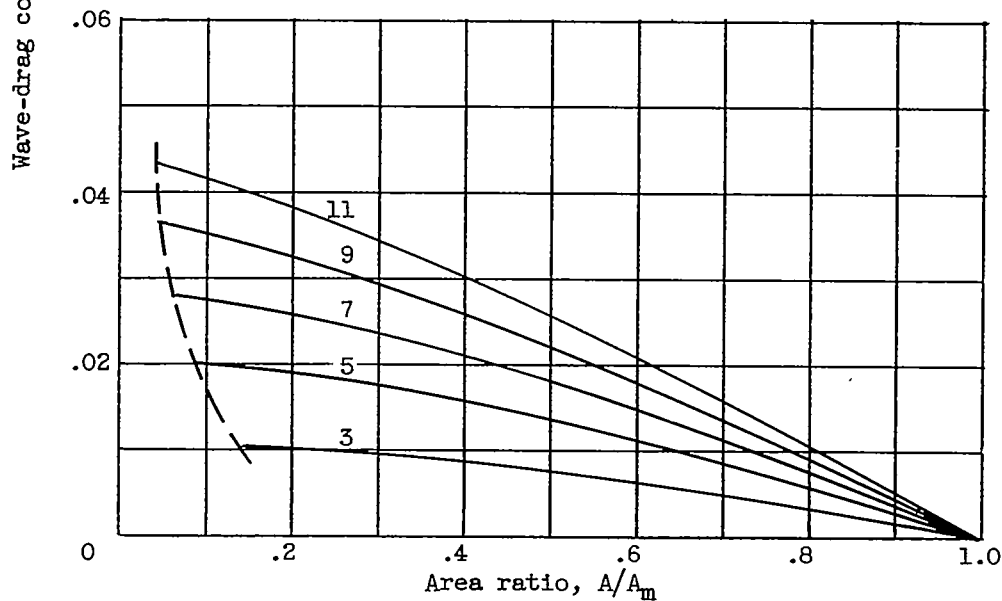

(d) Mach number, 4.5.

Figure 3. - Concluded. Variation of wave-drag coefficient with area ratio.

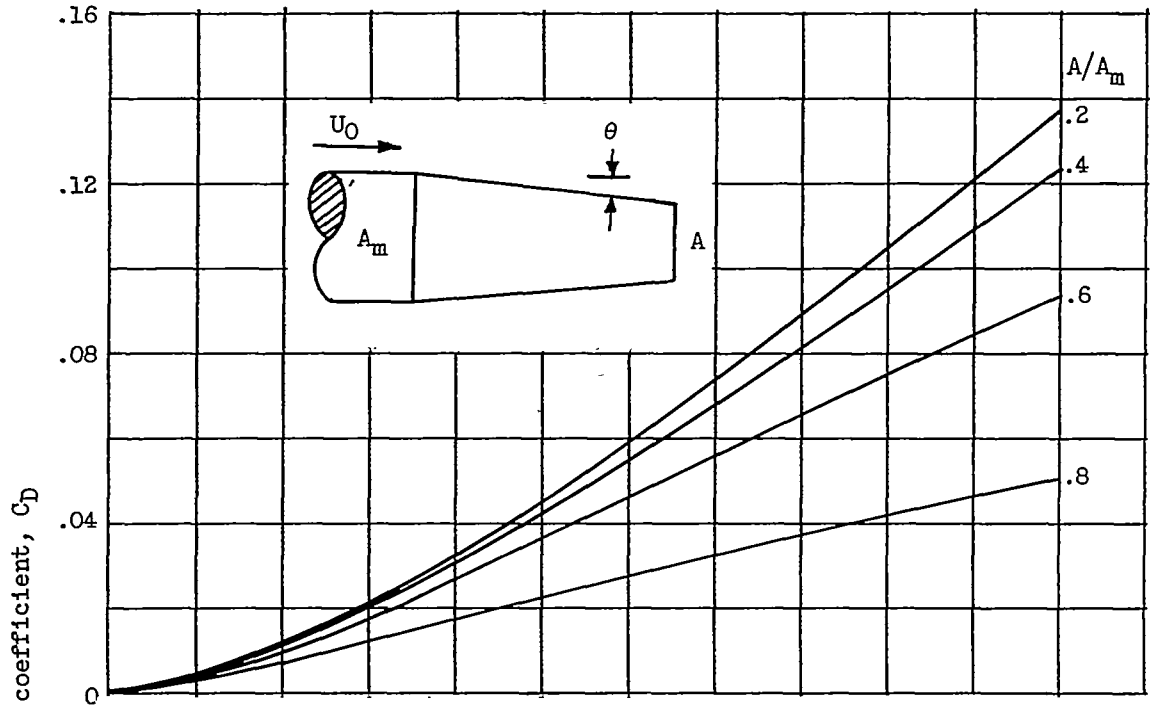

(a) Mach number, 1.5.

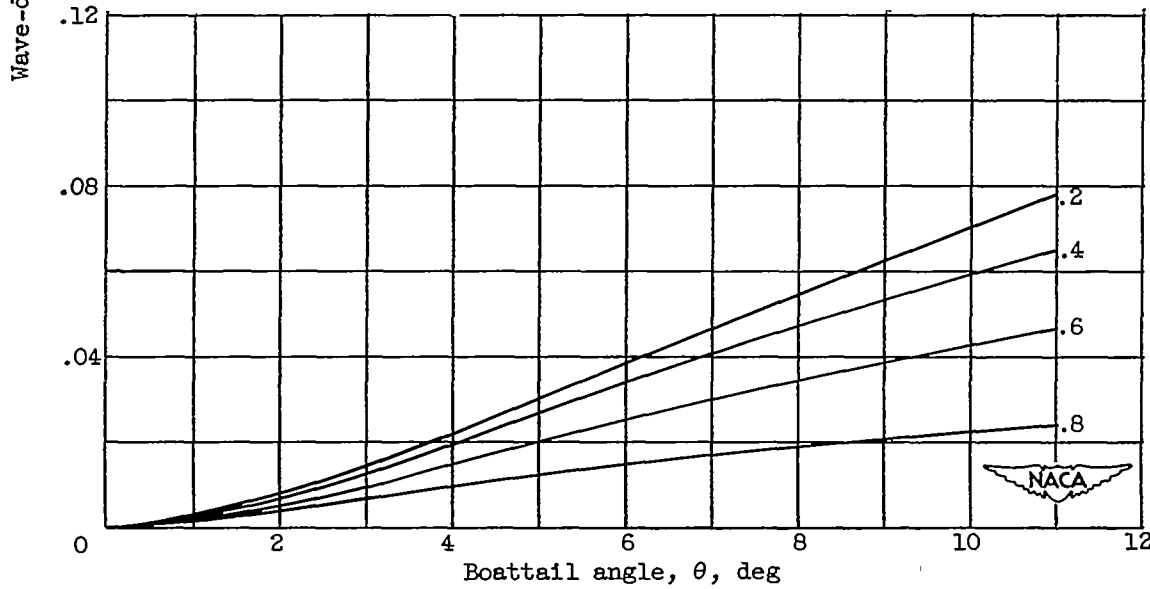

(b) Mach number, 2.5.

Figure 4. - Variation of wave-drag coefficient with boattail angle.

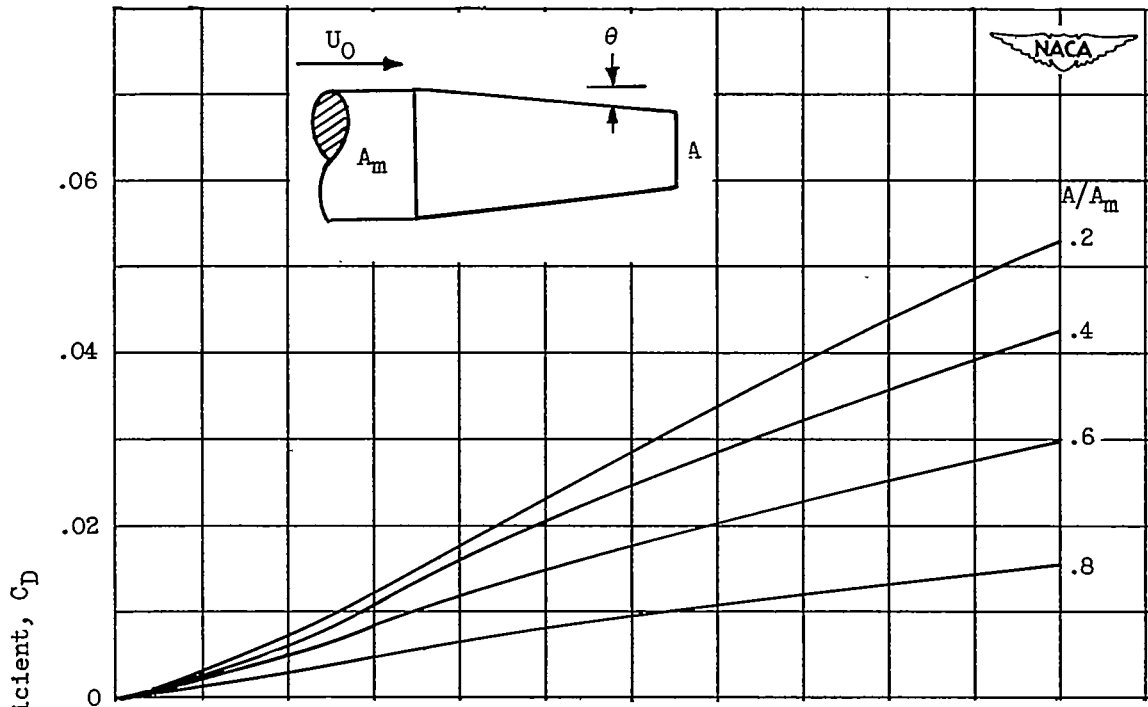

(c) Mach number, 3.5.

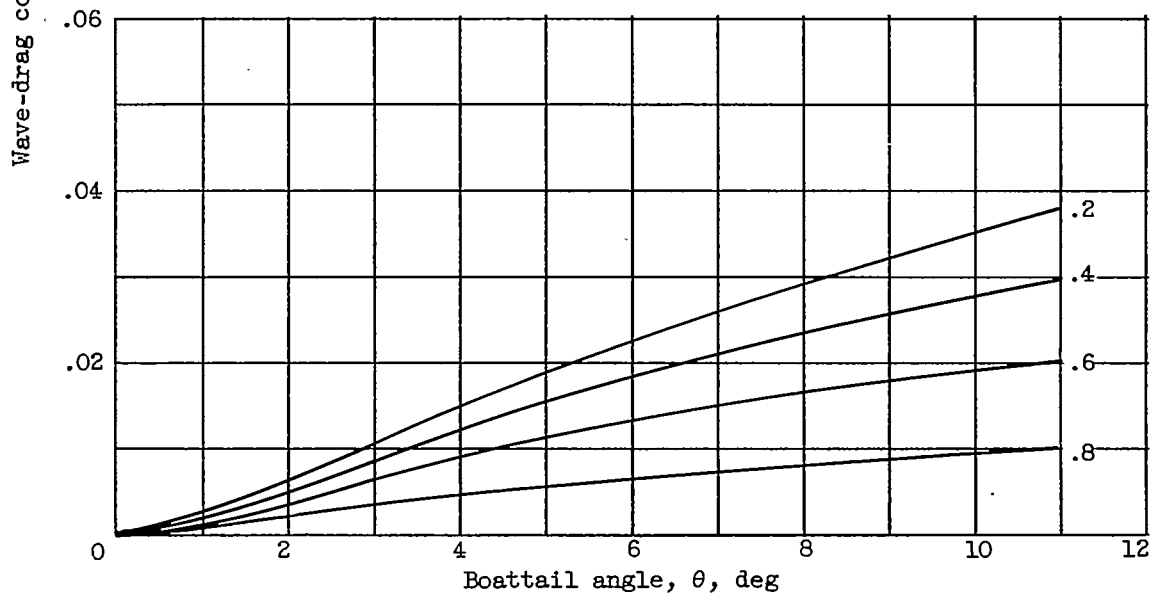

(d) Mach number, 4.5.

Figure 4. - Concluded. Variation of wave-drag coefficient with boattail angle.

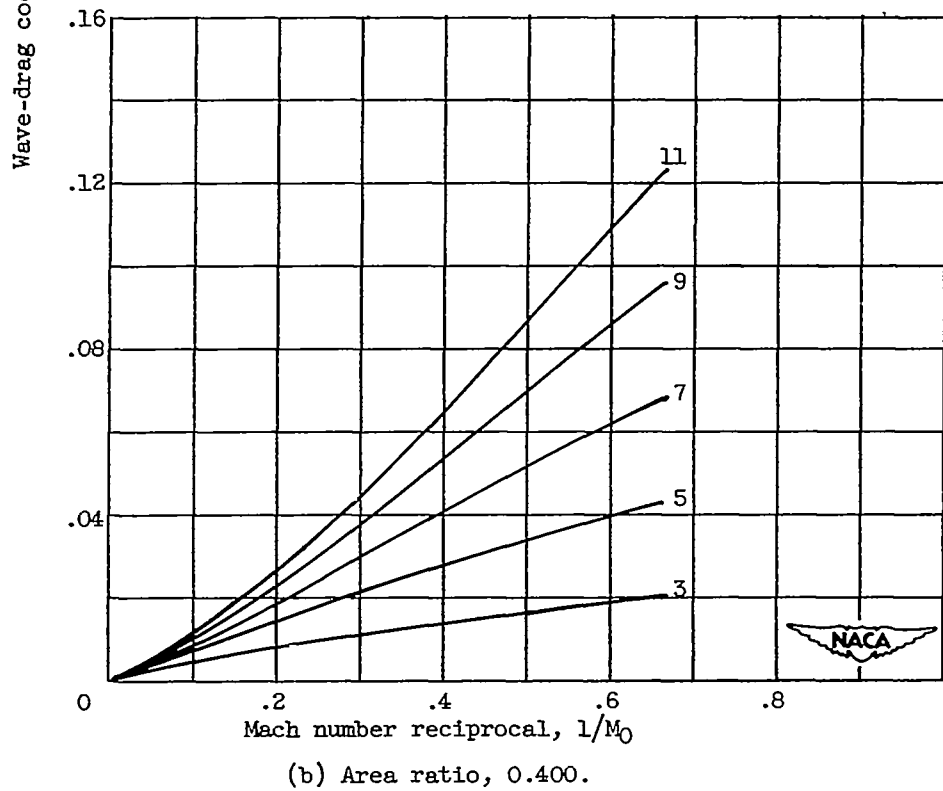
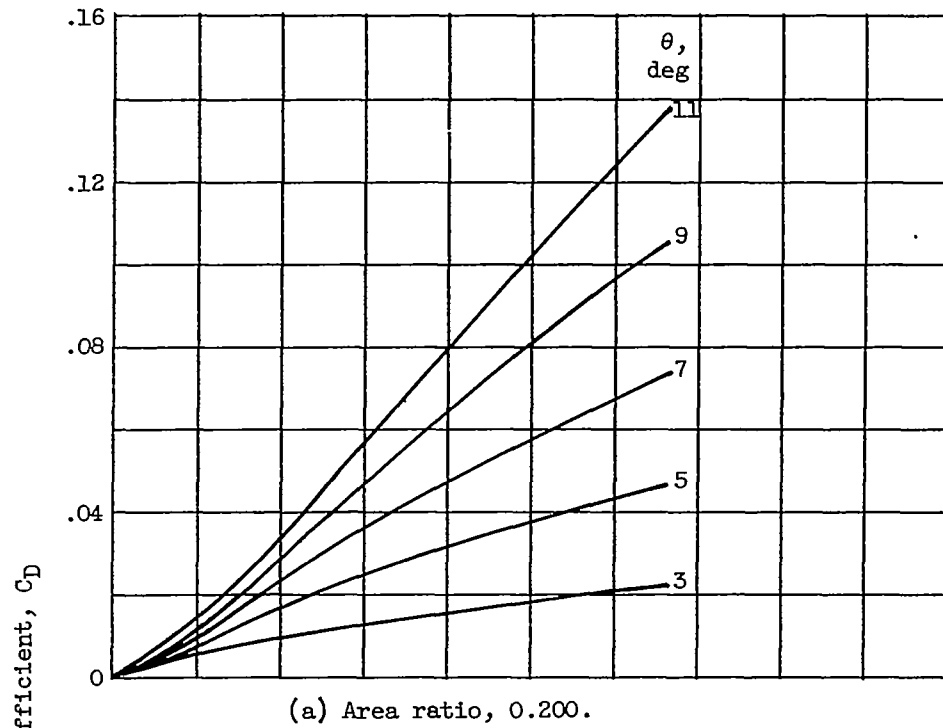
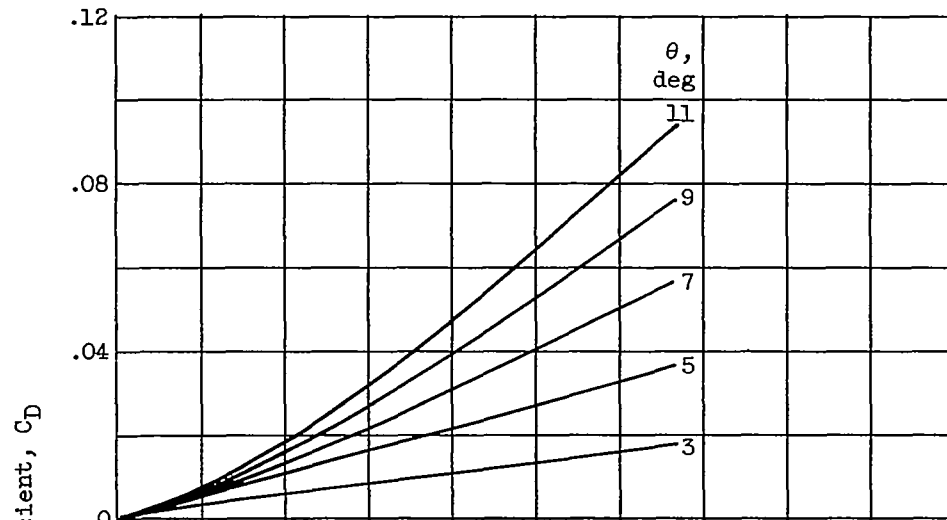
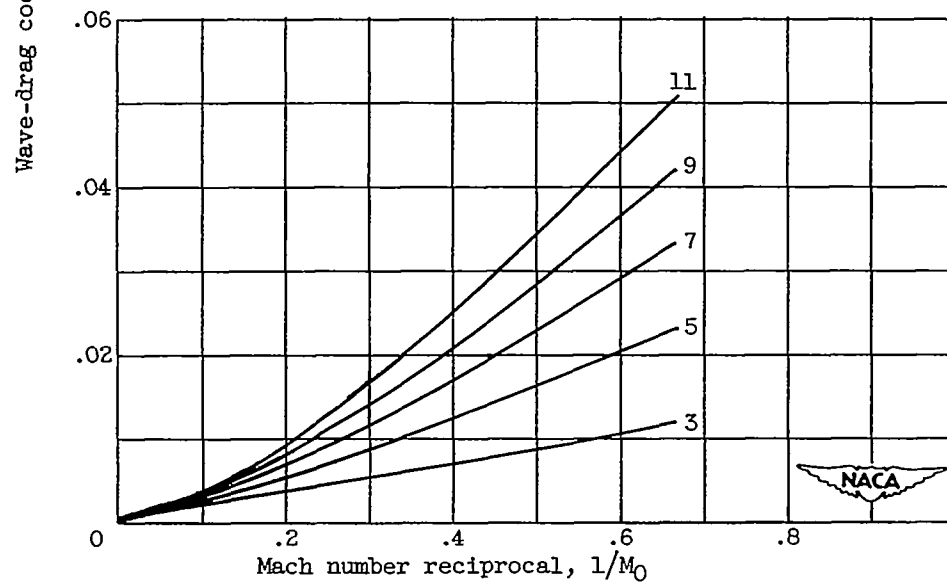

Figure 5. - Variation of wave-drag coefficient with reciprocal of Mach number.



(c) Area ratio, 0.600.



(d) Area ratio, 0.800.

Figure 5. - Concluded. Variation of wave-drag coefficient with reciprocal of Mach number.



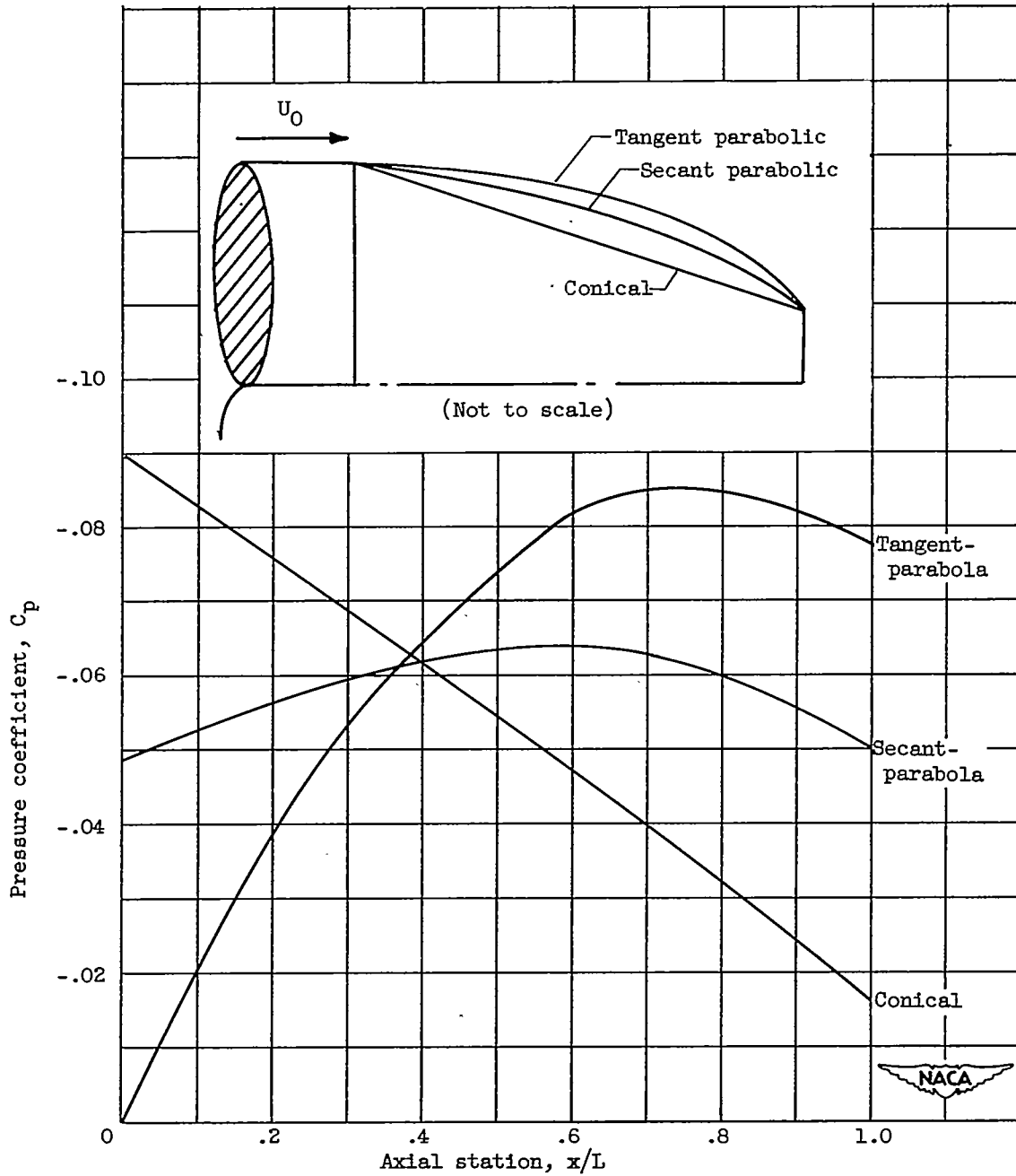

Figure 6. - Pressure distributions over three boattail contours.
Free-stream Mach number, 2.5; area ratio, 0.200.