

NACA TN 3006

CASE FILE
COPY

NATIONAL ADVISORY COMMITTEE FOR AERONAUTICS

TECHNICAL NOTE 3006

CORRELATION OF CALCULATION AND FLIGHT STUDIES OF
THE EFFECT OF WING FLEXIBILITY ON STRUCTURAL
RESPONSE DUE TO GUSTS

By John C. Houbolt

Langley Aeronautical Laboratory
Langley Field, Va.

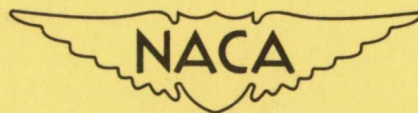

Washington
August 1953

NATIONAL ADVISORY COMMITTEE FOR AERONAUTICS

TECHNICAL NOTE 3006

CORRELATION OF CALCULATION AND FLIGHT STUDIES OF
THE EFFECT OF WING FLEXIBILITY ON STRUCTURAL
RESPONSE DUE TO GUSTS

By John C. Houbolt

SUMMARY

Studies made to evaluate the influence of wing bending flexibility on the structural response to gusts of two twin-engine transports and one four-engine bomber are summarized. The studies encompass some previously reported and some new flight studies, some calculation studies based on discrete- or single-gust encounter, and some new calculation studies for continuous-turbulence encounter, based on the methods of generalized harmonic analysis. It is shown that the discrete-gust approach reveals the general nature of the flexibility effects and leads to qualitative correlation with flight results. The studies based on the harmonic-analysis approach show good quantitative correlation with flight results and allow for a much greater degree of resolution of the flexibility effects. The good agreement shown suggests that a suitable approach for calculating flexibility effects is now available.

INTRODUCTION

This paper presents a summary of results obtained in flight and analytical studies which deal with the effect of wing flexibility on the structural response of an airplane in flight through rough air. The particular purpose of the paper is to show the degree of correlation that can be obtained between the flight-test and analytical results, and through this correlation to assess how well these flexibility effects may be analyzed.

Specifically, the following material is covered. The significant results of published flight tests are reviewed and some results of recent unpublished tests are given. Some results of studies made on the basis of single- or discrete-gust encounter are then reviewed and the extent of the correlation with flight-test results is indicated. Finally, some

recent analytical work on the more realistic conditions of continuous-turbulence encounter, based on the application of the method of generalized harmonic analysis, is presented and correlation with flight tests shown.

In order to permit earlier publication, the present paper has been confined largely to the significant findings of the investigations and details of the mathematical derivations have been omitted.

FLEXIBILITY MEASURES

From an analytical point of view several measures may be devised to indicate the extent to which flexibility effects are present. Generally these measures indicate how a particular structural-response quantity (such as acceleration) for the flexible airplane compares with what this response would be if the aircraft behaved as a rigid body. For the correlation purposes of the present report, however, the flexibility measures have been confined largely to the two types used in flight tests. One of these measures involves a comparison of the peak incremental accelerations developed at the fuselage with the peak incremental accelerations at the nodal points of the fundamental mode (see fig. 1), the latter acceleration being considered a close approximation to what the acceleration would be if the airplane were rigid. These two accelerations are of particular interest because both have been considered in the deductions of gust intensities from measured accelerations; they are different in general, as are all accelerations along the wing, because of structural flexibility, particularly wing loading. The other flexibility measure involves a comparison of the actual incremental wing stresses with what these stresses would be if the airplane were rigid. Since it is, of course, not possible to obtain the rigid-body reference strains in flight, some near-equivalent strain must be used. The general practice has been to assume that the rigid-body strains are equal to the strains that would develop during pull-ups having accelerations equal to the accelerations that are measured at the nodal points during the rough-air flights, and this practice has been followed herein.

FLIGHT STUDIES

In order to establish what the numerical values of these flexibility measures are in practical cases, flight tests were made in clear rough air with the three aircraft shown in figure 2 and designated A, B, and C as shown. References 1 to 4 report some of these flight tests. These

aircraft were chosen because they were available and because they were judged to be fairly representative of rather stiff, moderately flexible, and rather flexible aircraft, respectively. In this flexibility comparison, the factors which are considered to signify an increase in flexibility effects are higher speeds, lower natural frequencies, and greater mass distribution in the outboard wing sections. Figure 3 shows the type of acceleration results obtained from these flights. The ordinate refers to peak incremental acceleration at the fuselage and the abscissa refers to the peak incremental acceleration at the nodal points. Although only positive accelerations are shown in this illustration, a similar picture was obtained for negative acceleration values. The solid line indicates a 1 to 1 correspondence; whereas the dashed line is a mean line through the flight points. The slope of this line is the amplification which results from flexibility; thus, the fuselage accelerations are 5 percent greater on the average than the nodal accelerations for airplane A, 20 percent greater for airplane B, and 28 percent greater for airplane C. It is to be remarked that the picture is not changed much if given in terms of strains; that is, if the incremental root strains for the flexible case are plotted against the strains that would be obtained if the airplane were rigid, similar amplification factors are found.

SINGLE-GUST STUDIES

In an attempt to see whether these amplification factors could be predicted, some calculation studies were made by considering the airplane to fly through single sine gusts of various lengths. The calculations were made by the analysis given in reference 5, which is based on two degrees of freedom, vertical motion of the airplane and fundamental wing bending. The conditions used for speed, load distribution (payload and fuel), and total weight were similar to those used in the flight tests. Some of the significant results obtained are shown in figure 4 (see ref. 6 for additional related results). The ordinate is the ratio of the incremental root strain for the flexible aircraft to the incremental root strain that is obtained for the aircraft considered rigid. The abscissa is the gust-gradient distance in chords, as shown in the sketch. The curves indicate a significant increase in the amplification or response ratio in going from airplane A to B to C. It may be remarked that the amount of amplification is, in fact, related to the aerodynamic damping associated with wing-bending oscillations. This damping depends largely on the mass distribution of the airplane and is lower for higher outboard mass loadings. The curves thus reflect the successively higher outboard mass loadings of airplane B and airplane C.

The important point to note about this figure is that the general level of each curve is in good qualitative agreement with the amplification values found in flight. Thus, the 1.05 value for airplane A roughly

represents the average of the lower curve, the 1.20 value for airplane B the average of the middle curve, and the 1.28 value for airplane C the average of the upper curve. A more direct quantitative comparison would be available if a weighted average of the calculated curves could be derived by taking into account the manner in which the gust-gradient distances are distributed in the atmosphere. No sound method is available for doing this, however, and this over-all qualitative comparison will therefore have to suffice.

Figure 5 shows what is obtained when calculation and flight results are correlated in more detail. In this figure, the strain ratio is plotted against the interval of time for nodal acceleration to go from the lg level to a peak value. This interval, when expressed in chord lengths, is slightly different from the gust-gradient distance. The flight values shown were obtained by selecting from the continuous acceleration records a number of the more predominant humps that resembled half sine waves, and then treating these humps as though they had been caused by isolated gusts. The agreement seen between the calculated results and the flight results is actually surprisingly good when the complexity of the problem and the fact that the calculations are for a highly simplified version of the actual situation are considered. In contrast to the well-behaved single gusts assumed in the calculations, the gusts encountered in flight are not isolated but are repeated and are highly irregular in shape. These factors may well account for the higher amplifications found in flight, especially in the range of higher time-to-peak values; in this range it is to be expected that the amplification effects associated with the higher frequency components of the irregular gust shapes are superposed on the amplification effects of the predominant gust length, to lead to the higher effective values observed.

From the results thus far presented it may be concluded that a reasonably fair picture of flexibility effects may be obtained with the discrete-gust approach. It is found to give good over-all qualitative agreement with flight-test results and can be used to determine how one airplane compares with another in respect to the relative extent to which these effects are present. Detailed quantitative correlation is not feasible, however, since the degree of resolution permitted by the approach is limited. This is, of course, to be expected in view of the limited and unrealistic description of turbulence used.

CONTINUOUS-TURBULENCE STUDIES

In order to further the resolution it is appropriate to turn to an approach which considers the continuous-turbulence nature of the atmosphere. One procedure that suggests itself for treating the case of continuous turbulence, and which is presently receiving much attention, is

the adaptation of the so-called "power-spectral methods" of generalized harmonic analysis. This approach is based on the fact that, for linear systems, the "power-spectral functions" of a random input disturbance and an output response are related through the frequency-response characteristics of the systems. As a schematic illustration of the applications of this approach to the problem of response to gusts, figure 6 has been prepared. (A more thorough discussion of the approach is contained in ref. 7, which also gives the application to an airplane having the degrees of freedom of vertical motion and pitch.) The top sketch in the figure denotes a representative input "power-spectral-density function" which defines the characteristics of atmospheric turbulence; Φ_1 is indicative of the energy contained in the harmonic component of vertical velocity having a frequency Ω , this frequency being inversely related to the wave length L of the component as shown. (The area under this curve is, in fact, equal to the mean-square vertical velocity of the rough air.) The second sketch in figure 6 represents the frequency-response transfer function of the airplane; T represents the amplitude of the response variable of interest, such as stress, bending moment, or acceleration, which develops for a continuous sinusoidal-gust encounter. This function introduces the characteristics of the airplane, the various modes usually showing up as peaks, as is illustrated in the sketch for the free-body, fundamental wing-bending, and torsion modes. The third and fourth sketches represent output functions which are derived directly from the first two functions by the multiplications indicated. The third is the "spectrum" of the output response, the area A being equal to the mean-square value of the output response. This area can be used to determine the amount of time that will be spent in flight above a given load level; by considering, in addition, the area A_1 under the fourth function shown, it is possible to estimate the number of peak loads that may be expected at various load levels, a quantity which, for example, is of significance in fatigue studies.

This approach was applied in order to see what it would yield in the way of flexibility effects for the three aircraft considered herein. The input function chosen was that given in reference 7. The transfer functions were obtained by reducing the response equations of reference 5 to the special case of sinusoidal-gust encounter (harmonic response); this reduction is in effect a simplification, and for this reason the transfer functions are usually more easily calculated than are the dynamic-response curves of the discrete-gust approach. It may be of interest to note further that the reduction involves the introduction of the F (in-phase) and G (out-of-phase) oscillatory lift coefficients of flutter, and the associated coefficients (sometimes called P and Q) for sinusoidal gust penetration, to take over the role played by the unsteady-lift functions used in the transient cases. Thus coefficients appropriate to the case at hand may be inserted at will.

In the present application, bending stress at a station near the root of the wing was chosen as the response variable, and evaluation was made for flight conditions representative of those used in the flight tests. These conditions are indicated in table 1, together with the physical constants and basic parameters, as defined in reference 5, that apply. (It is remarked that the use of the theoretical lift-curve-slope value of 2π in place of more representative values has no serious consequence herein, since the final results to be presented are in a ratio form which is relatively insensitive to the lift-curve slope used.) Figure 7 shows the transfer functions that were obtained with the use of flutter coefficients for two-dimensional incompressible flow and an amplitude of the sinusoidal input gust of 1 fps. The solid curve is for the flexible aircraft; the dashed curve, for the aircraft considered rigid. These curves show quite clearly the different bias that each airplane has toward various frequency components of the atmosphere. The first hump is associated with vertical translation of the aircraft; the second hump, with wing bending. The percentage by which the flexible curves overshoot the rigid curves, of course, is a measure of flexibility effects. This overshoot is a reflection in the frequency plane of the characteristics of the transient-response curves shown earlier; it is noted that, as before, there is a significant growth in the percentage overshoot in going from airplane A to B to C. As was mentioned in the section on single-gust studies, this overshoot is related to the aerodynamic damping associated with wing-bending oscillations; thus, the curves denote a successive decrease in this damping in going from airplane A to airplane C.

Because the transfer functions for each airplane are different in shape, and especially because there is a marked difference in their height, considerable differences are to be expected in the output functions. While a presentation of the detailed results that can be derived from these output functions is beyond the scope of the paper, it is appropriate to consider the following sketch, which illustrates one of the significant types of result that can be derived, and which has a direct bearing on flexibility effects:

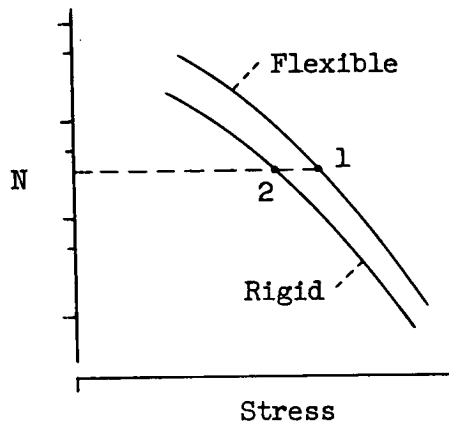

In this sketch the ordinate N refers to the number of stress peaks that occurs per second above a given stress level represented by the abscissa. As seen, one curve applies to the flexible airplane, while the other is for the airplane considered rigid. A convenient measure of the magnitude of flexibility effects can be found by taking the ratio of the stress for the flexible case to the stress for the rigid case at a given value of N (for example, the ratio of the stress at point 1 to the stress at point 2). In general, this ratio varies with stress level, being highest at the lower stresses but decreasing to a constant value at the high stress levels. For correlation with flight results, this ratio was determined for each of the three aircraft. The stress level chosen was in the range of the higher flight stress values; specifically, it was taken equal to twice the mean-square stress that developed.

Figure 8 shows a correlation of some of the results obtained by the harmonic-analysis approach with flight results. The ordinate is the previously used strain ratio, that is, the ratio of the peak incremental root bending strain for the flexible airplane to the peak incremental root bending strain for the aircraft considered rigid. The abscissa is the ratio obtained from the harmonic-analysis theory as explained in the preceding paragraph. The three circles are the results for the three airplanes. As a matter of added interest, a single acceleration point, which was the only one computed and which applied to airplane B, has been inserted in the plot as though the coordinates involved the ratio of fuselage to nodal acceleration. The good correlation shown by this plot is, to say the least, very gratifying; it shows that good correlation may be obtained between calculation and flight results and, moreover, indicates that the harmonic-analysis approach is a suitable method to use.

CONCLUDING REMARKS

Calculation and flight studies have been made on several airplanes to determine the manner in which gust loads are magnified by wing flexibility. This study indicates that an approach based upon single-gust encounter can be used to evaluate how one airplane compares with another in respect to the average of these flexibility effects. This discrete-gust approach also shows over-all qualitative correlation with flight results; it, however, does not permit detailed resolution of the flexibility effects, and hence direct quantitative correlation is not feasible. A more appropriate approach appears to be one which considers the continuous-turbulence nature of the atmosphere and which is based on generalized harmonic analysis. Not only does it permit airplanes to be compared with one another in detail but it also provides good quantitative correlation with flight results. It therefore appears that, through use of this continuous-turbulence approach, a suitable means is now available

for determining the magnitudes of flexibility effects. Moreover, many useful ramifications, such as application to fatigue studies, are provided as well.

Langley Aeronautical Laboratory,
National Advisory Committee for Aeronautics,
Langley Field, Va., July 2, 1953.

REFERENCES

1. Shufflebarger, C. C., and Mickleboro, Harry C.: Flight Investigation of the Effect of Transient Wing Response on Measured Accelerations of a Modern Transport Airplane in Rough Air. NACA TN 2150, 1950.
2. Mickleboro, Harry C., and Shufflebarger, C. C.: Flight Investigation of the Effect of Transient Wing Response on Wing Strains of a Twin-Engine Transport Airplane in Rough Air. NACA TN 2424, 1951.
3. Mickleboro, Harry C., Fahrner, Richard B., and Shufflebarger, C. C.: Flight Investigation of Transient Wing Response on a Four-Engine Bomber Airplane in Rough Air With Respect to Center-of-Gravity Accelerations. NACA TN 2780, 1952.
4. Murrow, Harold N., and Payne, Chester B.: Flight Investigation of the Effect of Transient Wing Response on Wing Strains of a Four-Engine Bomber Airplane in Rough Air. NACA TN 2951, 1953.
5. Houbolt, John C., and Kordes, Eldon E.: Gust-Response Analysis of an Airplane Including Wing Bending Flexibility. NACA TN 2763, 1952.
6. Kordes, Eldon E., and Houbolt, John C.: Evaluation of Gust Response Characteristics of Some Existing Aircraft With Wing Bending Flexibility Included. NACA TN 2897, 1953.
7. Press, Harry, and Mazelsky, Bernard: A Study of the Application of Power-Spectral Methods of Generalized Harmonic Analysis to Gust Loads on Airplanes. NACA TN 2853, 1953.

TABLE 1.- AIRPLANE LOADING, PHYSICAL CONSTANTS,
AND BASIC PARAMETERS

[See reference 5 for definitions of symbols]

	Airplane A	Airplane B	Airplane C
Fuselage load	Crew only	1/2 full	Crew only
Fuel load	1/2 full	1/2 full	full
W, lb	24,000	33,470	105,900
V, mph	185	255	250
S, sq ft	987	870	1,739
b, in.	1,140	1,120	1,700
a	6.28	6.28	6.28
c ₀ , in.	170	164	205
A	9	10	11.6
ρ, slugs/cu ft	0.00238	0.00238	0.00238
ω ₁ , radians/sec	27.4	21.4	15.6
μ ₀	28.4	46.8	59.3
μ ₁	0.266	0.748	1.132
λ	0.720	0.392	0.362
r ₁	0.189	0.225	0.190
r ₂	0.099	0.143	0.131
Wing station, in.*	50	56	60
r ₃	0.375	0.457	0.417
η ₀	5.56	15.94	30.88
η ₁	0.918	2.56	3.63
d	7.115	4.418	1.453
e	-0.137	-0.677	-0.919
h	0.405	0.289	0.356
M _{c₀} , ft ³	7,800	6,680	22,600
$\frac{z}{l}$, in. ⁻³	0.00446	0.00543	0.000912

*All values listed below the wing stations apply to the station indicated.



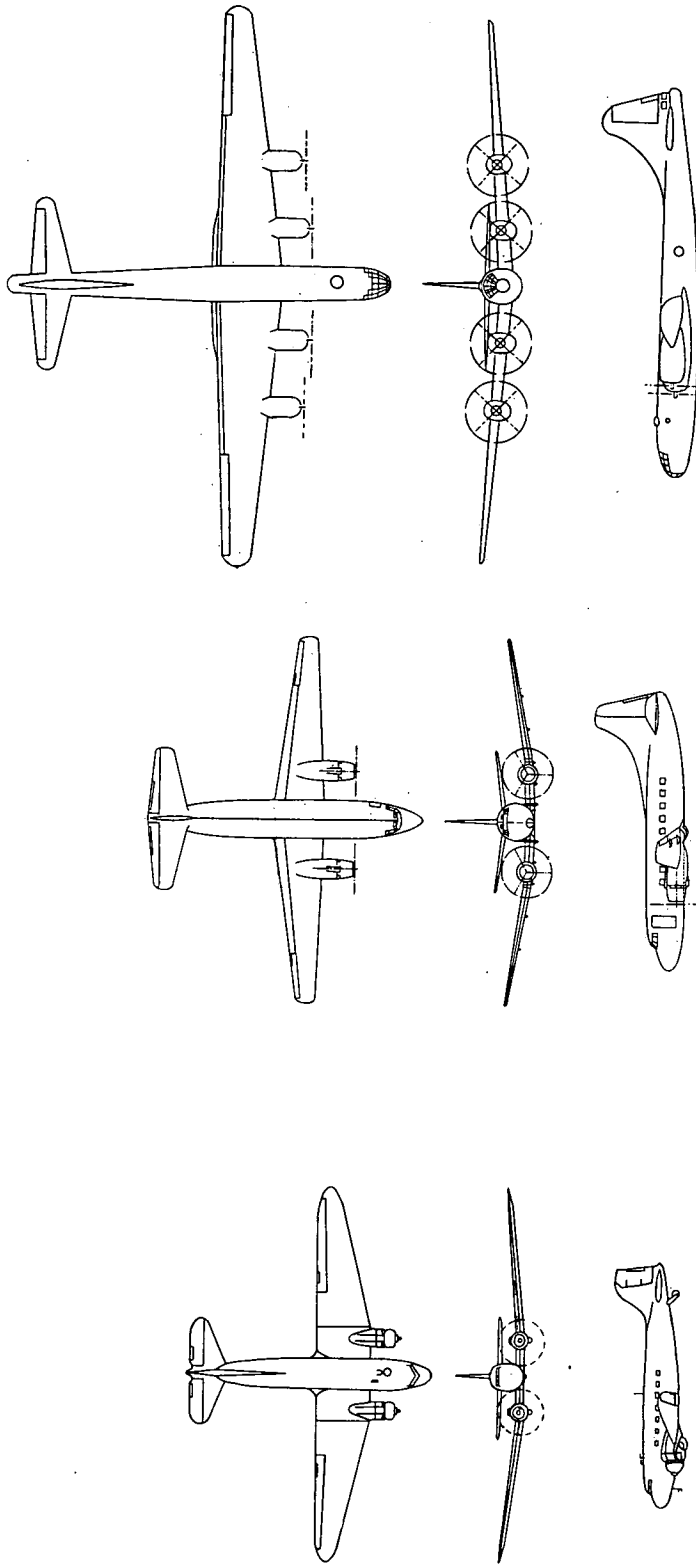

(a) Airplane A.

(b) Airplane B.

(c) Airplane C.



Figure 2.- Three-view sketches of test airplanes.

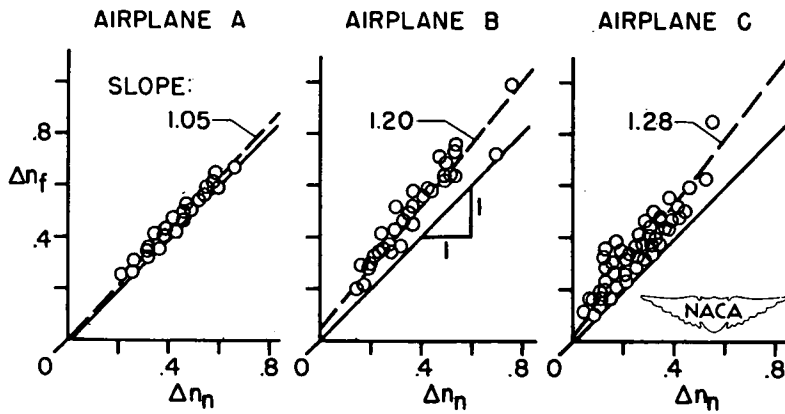

Figure 3.- Acceleration measured in clear rough air.

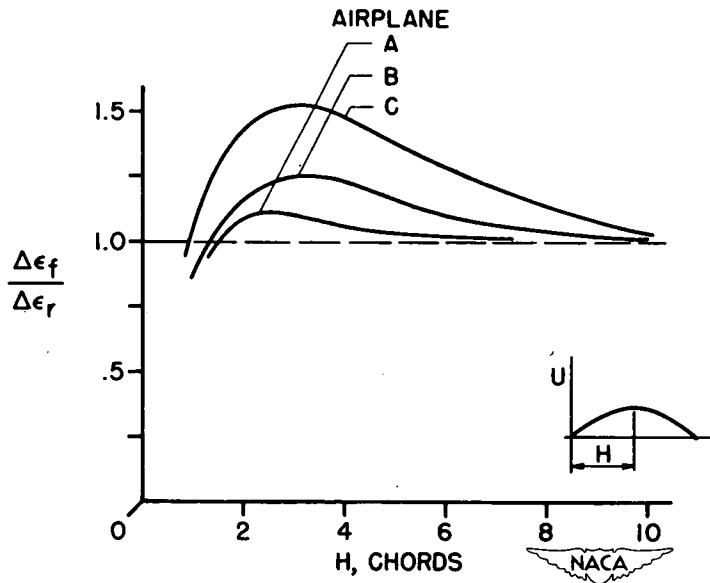

Figure 4.- Strain amplification for single-gust encounter.

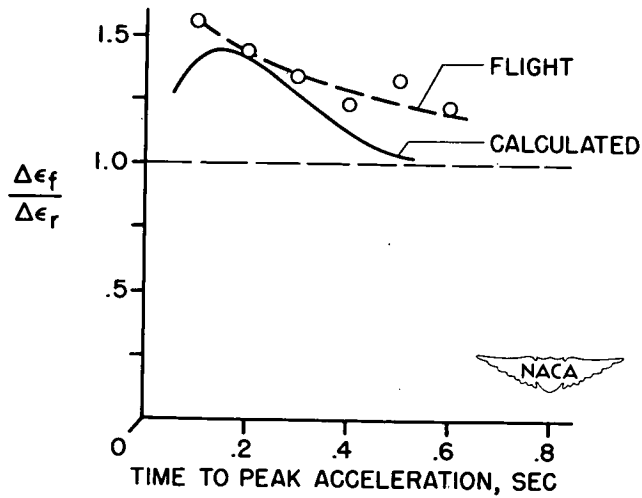

Figure 5.- Rough-air strain amplification for airplane C.

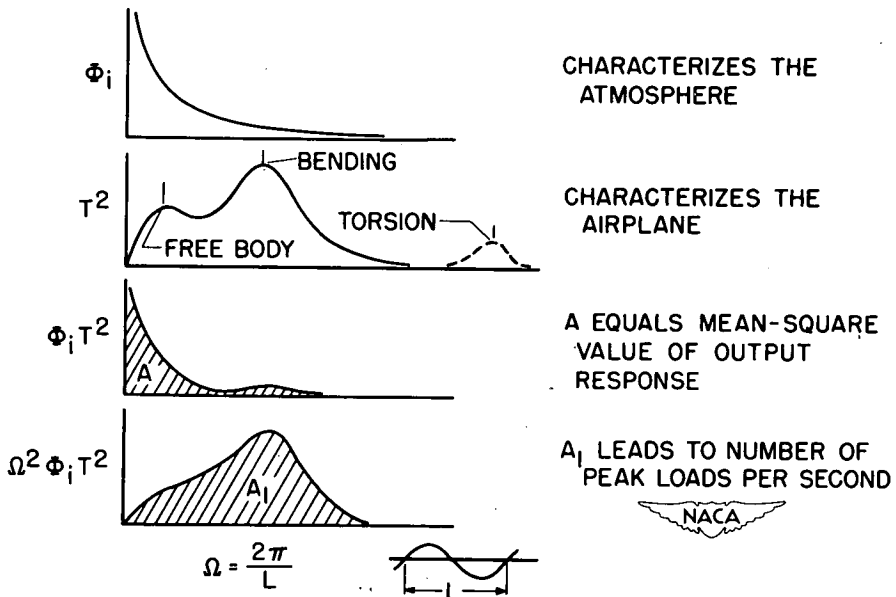

Figure 6.- Nature of generalized harmonic-analysis approach.

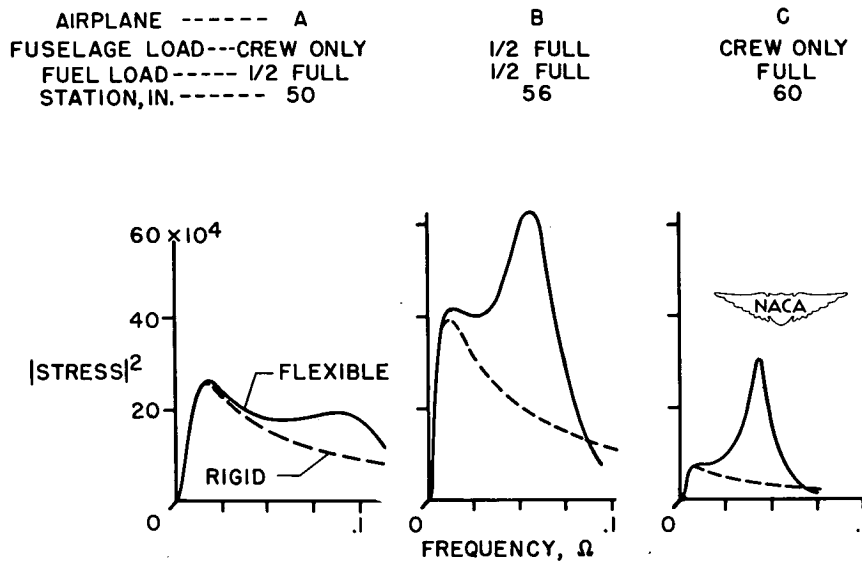

Figure 7.- Transfer functions.

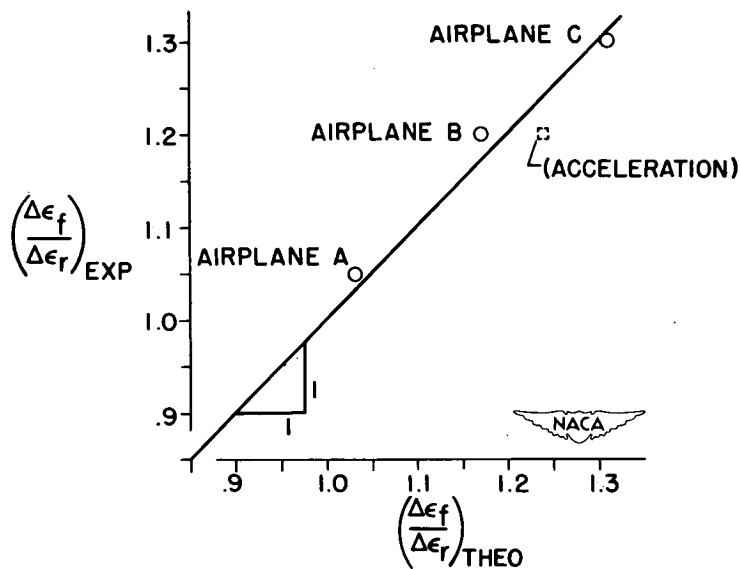

Figure 8.- Strain amplification for continuous turbulence.