

NACA TN 3799

NATIONAL ADVISORY COMMITTEE FOR AERONAUTICS

TECHNICAL NOTE 3799

AN AIR-FLOW-DIRECTION PICKUP SUITABLE FOR
TELEMETERING USE ON PILOTLESS AIRCRAFT

By Wallace L. Ikard

Langley Aeronautical Laboratory
Langley Field, Va.



Washington

October 1956

NACA FILE COPY

Loan returns on last
date stamped on last cover

PLEASE RETURN TO

DIVISION OF RESEARCH INFORMATION

WASHINGTON, D. C.

NATIONAL ADVISORY COMMITTEE FOR AERONAUTICS

TECHNICAL NOTE 3799

AN AIR-FLOW-DIRECTION PICKUP SUITABLE FOR
TELEMETERING USE ON PILOTLESS AIRCRAFT¹

By Wallace L. Ikard

SUMMARY

A free-swiveling vane-type pickup for measuring air flow direction in both the angle-of-attack and angle-of-sideslip directions is described. The device, which is intended to telemeter flow direction from pilotless aircraft, has variable-inductance outputs suitable for use in the 100 to 200 kcps subcarrier frequency range of the NACA FM-AM telemetering system. Preliminary test results indicate that it can also be adapted for use with the audio subcarrier frequencies of the Research and Development Board standard FM-FM telemetering system.

Test results are presented which indicate that the pickup is aerodynamically stable and has an accuracy, obtained from a bench calibration, of better than 0.3° under conditions including acceleration up to 20g in any direction, Mach numbers from 0.5 to 2.8, and dynamic pressures up to at least 65 psi.

Equations and curves which can be used to obtain flow direction at the center of gravity of a maneuvering model are presented.

INTRODUCTION

In the determination of many aerodynamic parameters of aircraft in free flight, it is necessary to know the attitude of the airframe with respect to the relative wind. Various instruments have been used on piloted aircraft to measure flow direction, but these instruments are generally unsuitable for use on high-speed pilotless-aircraft models because of their large size or their inability to withstand the large accelerations and aerodynamic loads which are encountered.

Early in the development of the NACA pilotless aircraft research programs, a simple self-aligning vane-type instrument for measuring flow direction was designed and used (ref. 1). This instrument had the

¹Supersedes declassified NACA Research Memorandum L53K16 by Wallace L. Ikard, 1954.

necessary strength and small size; although this instrument was free to rotate about only one axis and thus gave flow direction in only one plane, valuable data were obtained from many models.

A desire to obtain more complete research data from each flight soon made it apparent that a dual-flow-direction instrument which could completely define the flow direction with respect to the aircraft axes should be devised.

The purpose of this report is to outline the problems, which were encountered in the design and use of such an instrument, and to present the performance characteristics of the final instrument.

DESIGN REQUIREMENTS

Requirements for a flow-direction pickup to be used in the NACA pilotless aircraft research programs are as follows:

Accuracy: For use in the pilotless aircraft research programs, the instrument must have absolute accuracy of at least 0.2° and a resolution of at least 0.1° under acceleration loads of 20g in any direction with dynamic pressures ranging from 1 to 90 psi at any Mach number from 0.5 to 3.0. Accelerations of the order of 75g should cause no permanent changes in calibration.

Dynamic response: The natural frequency and damping characteristics of the instrument should be such that accurate data can be obtained from models maneuvering at frequencies up to 15 cps in the operating range described previously.

Size: Because of the small scale of some models used in the research programs, the size of the instrument is an important factor; a frontal area of less than 1 square inch is desirable.

Mounting position: In order to minimize the effects of flow disturbances, the critical aerodynamic surfaces of the device should be forward of the model and mounting.

Angular range: The instrument should be capable of measuring flow angularity up to 15° from an arbitrary mounting axis.

Electrical output: Separate outputs proportional to the local angle of attack and angle of sideslip with no interaction between the two quantities are required. For use with the NACA FM-AM telemetering system, the electrical output should consist of an inductance change of approximately 50 microhenries. The inductance pickoff, which must be suitable

for use in the 100 to 200 kcps band, should have a nominal value no greater than 0.5 millihenry.

Temperature stability: Since skin temperatures of 400° F to 700° F may be reached during short periods of flight at high supersonic speeds, the device should have sufficient temperature stability and thermal lag to operate properly under these conditions for periods of 1 to 2 minutes.

Simplicity: Since each pickup is expended in flight, the calibration should be direct and simple and the cost should be low.

DEVELOPMENT OF INSTRUMENT

Systems which give a more or less direct indication of flow direction were considered before undertaking the design of the instrument described herein and may be listed in three general groups: instruments in which a measurement is made of differential pressure between appropriately located orifices on a hemisphere, cone, or other aerodynamic shape (ref. 2), null-seeking differential-pressure instruments (refs. 3 and 4), and free-swiveling vane-type instruments (refs. 1 and 5).

The vane-type system of measurement was chosen for several reasons. The first system requires accurate measurement of a wide range of relatively low pressures, which is very difficult to obtain under the acceleration loads encountered. Systems using the second method have been too bulky or complex to meet the requirements of simplicity and mounting forward of small models. Previous experience with the third method, vane-type pickups, at the Langley Laboratory indicated that such a device could be made to meet the requirements.

The first experimental pickup was constructed and tested with the head configuration shown in figure 1(a), which consisted of an ogive body tangent to the conical nose, stabilized with four 60° delta vanes. (All vanes described herein are flat plates with sharp leading edges and blunt trailing edges.) The internal configuration of figure 2(b) was used in this and all subsequent tests. Very satisfactory angular calibrations of this model were obtained in the Langley 9- by 12-inch supersonic blowdown tunnel at Mach numbers of 1.4, 1.6, and 1.96.

Further tests, however, proved the configuration to be dynamically unstable in a narrow Mach number range between approximately 0.93 and 0.97. A theory was advanced that this instability was the result of an unstable shock-wave condition existing near the rear of the body as the local velocity of flow passed through Mach number 1.0. In order to check this theory, the original configuration was modified as shown in figure 1(b)

by addition at the rear of the body of an annular spoiler extending 0.1 inch into the airstream to provide a stable point of attachment of a strong shock wave. Tests proved that the spoiler greatly reduced oscillations at transonic speeds but resulted in poor operation at subsonic speeds.

In an effort to obtain a configuration possessing good stability at transonic speeds along with other desirable characteristics, the body shape was modified as shown in figure 1(c), and one instrument was constructed using each of the three different vane configurations (shown as dotted lines in figure 1(c)). The body was essentially the original configuration with the exception that the rear part of the ogive was replaced with a tangent 5° conical section in order to reduce shock-wave difficulties and to increase the aerodynamic damping. Theory shows (ref. 6) that flaring the body in this manner moves the aerodynamic center of pressure rearward and increases the aerodynamic damping. In order to increase the effectiveness of the aerodynamic damping further, the moment of inertia of the moving parts was reduced to a minimum.

Wind-tunnel tests were made on these three configurations in the Langley high-speed 7- by 10-foot tunnel at Mach numbers from 0.5 to 1.1. Although flow conditions in this tunnel were rough and would, of course, cause more oscillation in the pickup than would be encountered under free-flight conditions, tests there served as a means of comparing instruments under adverse conditions. Results of these tests were as follows: The rectangular-vane configuration (labeled no. 1) oscillated violently at about 20° double amplitude starting at about a Mach number of 0.95. This test was not continued higher in Mach number to determine whether the oscillation would stop. Both the delta (no. 2) and arrowhead-vane (no. 3) configurations operated satisfactorily throughout the Mach number range of the test. Although tunnel roughness showed up slightly more with the delta-vane configuration, it was selected for the final design because it is mechanically stronger and less difficult to form by die casting.

DESCRIPTION OF INSTRUMENT

Sketches of the final configuration of the dual-flow-direction pickup which was designed to meet the stated requirements are shown in figure 2. The pickup makes use of a sting-mounted, vane-stabilized head which is pivoted well ahead of its aerodynamic center of pressure on a free-swiveling universal joint. Body and vanes are combined so that they rotate as a unit; thus, the aerodynamic surfaces are placed ahead of all fixed parts. The delta vanes are swept back 60° , are flat in cross-section, and have sharpened leading edges and blunt trailing edges. The body, which is shown in more detail in figure 1(c), is an ogival shape modified by addition of conical tip and conical afterbody sections.

Overall exposed length of the instrument when mounted is 7 inches. The frontal area is approximately 1 square inch. Overall weight, including head and mounting sting, is 0.32 pound.

The universal joint pivot (fig. 2(b)), which is provided with adjustments for removing play from the bearings, acts to separate the flow-direction measurement into two components. Bearing axis A, bearing axis B, and the instrument mounting axis intersect at a common point. With this arrangement, the inductance of coil A, which is controlled by the relative position of core A, varies only when the head rotates about axis A. The inductance of coil B likewise varies only when the head rotates about axis B.

With this internal configuration, if the instrument is mounted with axis A parallel to the lateral axis of the aircraft, the local angle of attack and angle of sideslip are indicated, with no interaction, by the inductance of coil A and coil B, respectively. The definitions of these two terms are given in reference 7 and may be stated as follows:

Angle of attack: The acute angle between two planes defined as follows: One plane includes the lateral and longitudinal axes of the aircraft; the other plane includes the lateral axis of the aircraft and the relative wind vector.

Angle of sideslip: The acute angle between the plane of symmetry of the aircraft and the relative wind vector.

The inductance pickoffs, as sketched in figure 2(b), each consist of a conical powdered iron core which moves on an arc through a powdered-iron enclosed coil. The coil, of enameled copper wire, is wound on a small plastic spool. In a typical installation using the maximum full-scale range of 30° , the coil uses 85 turns of no. 38 wire and has an inductance at 0° of 0.09 millihenry. The total variation of inductance over the calibrated range is 0.04 millihenry, an inductance change of 1.5 percent per degree. This sensitivity figure holds to within about 5 percent for any inductance value used on the subcarrier frequencies of the NACA telemetering system.

With the exception of bearings and aerodynamic surfaces, dimensional tolerances used in the construction are ± 0.005 inch. On the die-cast heads, vane alignment is held to within $\pm 0.1^\circ$ of the body axis; concentricity of the body sections is held to ± 0.001 inch full indicator reading. Bearing shafts and sleeve bearing bores are held to tolerances of ± 0.0002 inch on the diameter.

TELEMETER

In the NACA telemetering system, the pickup controls the frequency of a subcarrier oscillator. Several such oscillators, operating in different frequency bands between 100 and 200 kcps, simultaneously amplitude-modulate a 217 mcps carrier; this modulation is transmitted from the model to the ground receiving station. At the ground station, the subcarrier frequencies are separated and fed into individual frequency discriminators which produce direct-current outputs proportional to the frequency deviation of the subcarrier oscillator. These current outputs are recorded on multichannel oscillographs.

Each of the variable-inductance outputs of the dual-flow-direction pickup is connected into the resonant inductance-capacitance circuit of a subcarrier oscillator. The oscillator may be tuned to any subcarrier frequency; the internal oscillator inductance in series with the pickup is adjusted so that full-scale variation of the pickup inductance results in a total frequency deviation of approximately 2 kcps.

The errors in the telemetering system due to instability of the electronic circuits, calibration, and reading errors are conservatively estimated to be between 1 and 2 percent of full scale, exclusive of pickup errors.

INSTRUMENT PERFORMANCE

Aerodynamic Performance

The aerodynamic performance of the final instrument (fig. 2) has been determined in wind tunnels at Mach numbers from 0.3 to 1.1 and the instrument has been used on free-flight models at Mach numbers up to 2.8. The aerodynamic characteristics of this instrument under conditions of dynamic pressures different from those obtainable in wind tunnels were determined by the method of analysis given in the appendix.

Frequency response.- The dynamic response of a device such as this instrument can be determined from measurements of natural frequency and damping coefficient under the desired conditions. A convenient means of experimentally determining these factors in a single-degree-of-freedom instrument having low damping is to apply an instantaneous change of input and analyze the resulting oscillation. These factors were determined for the dual-flow-direction pickup in wind tunnels by locking the head at some angle of attack and recording the damped oscillation as it was released at the desired Mach number. A typical damping record, obtained at a Mach number of 0.8, is shown in figure 3.

The instrument has a high natural frequency, as shown in figure 4, where natural frequency is plotted against Mach number at pressure altitudes of zero, 25,000 feet, and 50,000 feet. These data, up to a Mach number of 1.1, were obtained from tests on the final instrument configuration. Data above a Mach number of 1.1 are approximate, inasmuch as they were calculated from data obtained in testing a similar configuration having a slightly different body shape. The natural frequency of the instrument in the range of Mach numbers from 0.3 to 1.96 varies from 31 cps to 350 cps at sea level and from 10.5 cps to 120 cps at an altitude of 50,000 feet.

Tests on the instrument have proven the damping produced by bearing friction to be negligible. The aerodynamic damping of the head determined from measurements at Mach numbers of 0.3, 0.43, 0.8, and 1.0 is approximately 5 percent of critical value at sea-level conditions and is essentially independent of Mach number.

A damping coefficient this low would be insufficient for many instrument applications, but experience has proven that the low damping causes no trouble in free-flight work, provided the device is securely mounted and kept out of fluctuating flow disturbances caused by the model. Amplitude and phase responses are satisfactory in use because natural frequencies of the models under similar conditions will not exceed about 10 percent of the pickup natural frequency.

It is shown in the appendix, however, that the aerodynamic damping coefficient is proportional to the square root of static pressure. Therefore, in order to retain a reasonable amount of damping when the instrument is operating at high altitudes, a small amount of high-viscosity silicone fluid is introduced into the sleeve bearings of the universal joint to provide lubrication and viscous damping. It can be seen from equation (7) that the effectiveness of this viscous damping depends on flight conditions, since the aerodynamic spring constant k is variable whereas the damping factor λ introduced by viscous damping is relatively constant. The effect of the viscous damping is greatest under the conditions of low spring constant and low natural frequency. In order to keep the damping coefficient of the instrument from becoming large at low natural frequencies and bringing about appreciable phase lags which vary with flight conditions, the amount of viscous damping introduced is kept low and is approximately 1 to 2 percent of the critical value when the natural frequency is 50 cps.

Hunting or oscillation.- It has been suggested that flat vanes such as those used in this instrument may have an aerodynamic "dead spot" or region of neutral stability near an angle of attack of 0° . However,

since the occasional oscillations of the pickup which have been observed in free-flight use on rocket models have a total amplitude of less than 0.2° , this effect, if present, is not considered to be serious.

Accuracy of laboratory calibrations.- Individual wind-tunnel calibration of an instrument which is used only once is not, of course, economically feasible. A simple protractor jig such as shown in figure 5 is used to calibrate the dual-flow-direction pickup. It has been impractical up to this time to check by wind-tunnel test the accuracy of such a calibration on the final instrument. However, tests were made on the original configuration of figure 1(a), and since its characteristics are similar except in the transonic range, it is believed that similar results could be expected from the final instrument. These angular calibrations were made in the Langley 9- by 12-inch supersonic blowdown tunnel at Mach numbers of 1.4, 1.6, and 1.96, with dynamic pressures between 10.5 and 12.5 psi. In these calibration runs, the pickup was mounted, as shown in the photograph of figure 6, on a rotatable strut designed to keep the head at the same location in the tunnel while the mounting was rotated through the calibration range. The pickup was calibrated at several combinations of angles of attack and angles of sideslip. By accounting for previously measured tunnel stream angles and correcting for strut deflection and for backlash of the rotating mechanism, the angle of air flow relative to the instrument mounting was determined with an estimated accuracy of $\pm 0.05^\circ$. Each calibration run required approximately 3 minutes time, during which readings were taken in 2° increments through a range of $\pm 10^\circ$. Readings at an angle of attack of 0° were made at the beginning, middle, and end of each run so that corrections could be made for output drift with temperature. Maximum thermal drift due to an increase of approximately 100° F in the pickup temperature during a run was equivalent to about a 0.2° change in angle of attack.

The errors in protractor calibrations as obtained from wind-tunnel checks at the three Mach numbers are shown in figure 7. Through a total of eight calibration runs (104 data points) the maximum deviation of any point from the true reading was 0.4° . Eighty-five percent of all readings were within 0.2° , whereas 50 percent were within 0.1° . It should be noted that, when these readings were taken, normal telemetering procedures and equipment were used, with the exception that the radio-frequency link was eliminated; that is, the pickup was connected to two subcarrier oscillators whose outputs were fed directly into frequency discriminators connected to a recording oscillograph. Angular readings of the pickup were determined in the normal way by reading of the oscillograph record. The errors quoted above represent 0.5 percent to 1.0 percent of the full-scale calibrated range.

Mechanical Performance

The accuracy of a pickup such as this depends to a great extent on the mechanical precision with which it is constructed. The use of simple protractor-type bench calibrations requires alinement of the aerodynamic surfaces to be symmetrical; proper operation under acceleration and aerodynamic loads requires that the bearings fit well with very little friction and that the movable parts are precisely balanced. It is believed that, if the tolerances listed under description of the instrument are held, future instruments will have aerodynamic accuracies as good as those listed in the previous section.

Balance and bearing friction.— An analysis of the effects of unbalance and bearing friction on the accuracy of the pickup requires knowledge of the aerodynamic restoring moment. For any given condition of Mach number and altitude, the restoring moment per degree, which can be considered to be an aerodynamic spring constant, can be determined from the moment of inertia of the head and its natural frequency. The following relationship can be obtained from equation (6):

$$k = \frac{4\pi^2}{57.3} f_n^2 I \quad (1)$$

where

- k spring constant, in-lb/deg
 f_n natural frequency, cps
 I moment of inertia, in-lb-sec²

The moment of inertia of the rotating parts, which weigh 25 grams, was measured and found to be 0.06×10^{-3} in-lb-sec². Substituting this value into equation (1) gives

$$k = 0.04 \times 10^{-3} f_n^2 \quad (1a)$$

The accuracy with which the instrument can be balanced is limited by the bearing friction, which has been held below 0.001 inch-pound in the instruments constructed. Balance is adjusted until the head will not rotate when placed in any position and vibrated slightly.

The torque caused by head unbalance depends directly on the acceleration encountered in flight and will cause an error dependent upon the

aerodynamic spring constant at the particular flight condition. For instance, at a Mach number of 0.5 at sea level, the head has a natural frequency of 50 cps and an aerodynamic spring constant of 0.1 in-lb/deg as determined from figure 4 and equation (1a). Thus, since the maximum unbalance is held to less than 0.001 in-lb in any direction, the maximum unbalance torque caused by an acceleration of 10g in any direction will be about 0.01 in-lb and will cause an error of 0.1° . Errors caused by acceleration and unbalance will decrease when flight conditions cause the aerodynamic spring constant to increase from the above value, which occurs under conditions corresponding to impact pressure q_c approximately equal to 2.7 psi.

Calculations of errors which might be brought about by increased friction when accelerations and aerodynamic loads increase bearing loading are necessarily approximate. Calculations of the friction of the shaft on the sleeve bearings were made; these calculations were based on standard friction coefficients for the materials used. By using the measured weights of the head parts and approximate aerodynamic drag coefficients for such a shape, calculations were made for several conditions of Mach number, dynamic pressure, and acceleration. The friction error was found in all cases to be smaller than 0.1° . The presence of very low amplitude oscillations on flight records obtained from the instrument bear out the results of calculations in indicating that frictional forces are insufficient to cause appreciable error.

Mechanical strength.- In order to check the structural soundness of the instrument, particularly of the internal parts, the output has been observed during application of static and shock accelerations up to 100 g. In order to prevent rotation due to residual unbalance, the angular position of the vanes with respect to the sting was fixed. No readable output change resulted from the acceleration tests, and later inspection disclosed no damage.

Electrical Performance

Inasmuch as the instrument was designed primarily for use in the NACA FM-AM telemetering system, most of the electrical performance data pertain to operation in the subcarrier frequency range between 100 and 200 kcps. Some testing, however, has been done to determine the feasibility of using it with the audio subcarrier FM-FM telemetering system.

Inductance pickoff sensitivity.- Typical inductance values used with the instrument on NACA telemetering channels range between approximately 0.07 and 0.25 millihenry at an angle of 0° , depending on channel frequency and full-scale angular range. This inductance changes about 1.5 percent per degree of angle. Full-scale calibrated ranges as low as $\pm 4^\circ$ are practical.

A typical calibration curve of channel frequency against angle is shown in figure 8. Linearity of this calibration, expressed as the percent deviation from the best straight line, is 1.8 percent.

Temperature stability.- Since the instrument experiences aerodynamic heating, tests were made to determine the effect of slow and rapid heating on the zero frequency and sensitivity.

When the instrument was tested at ambient temperatures from -60° to 350° F, it was found that the frequency reading at 0° decreased and the slope of the calibration curve (sensitivity) increased, both changing at the rate of 1.0 percent of the full-scale value per 100° temperature change. Experience with inductance pickoffs of this type indicates that these temperature shifts are essentially a characteristic of the inductance unit alone.

In order to simulate the rapid heating experienced in rocket-propelled flight at high Mach numbers, checks were made in which the head of the instrument was heated rapidly, with a torch, from room temperature to about 400° F. Measurements were made simultaneously of head temperature, inductance pickoff temperature, and subcarrier oscillator frequency. The temperature of the inductance pickoff was found to rise at an initial rate of approximately 100° per minute, with output frequency changing at the rate of 1 percent of full scale per minute.

The above tests did not take into account possible errors due to vane warpage with temperature change; this warpage can take place if head castings are not properly stress relieved.

Operation on audio channel frequencies.- In order to check the feasibility of using the flow direction pickup on audio subcarrier frequencies, one instrument was assembled by using the existing powdered iron components and coil form and substituting a winding of 1000 turns of no. 43 wire. The inductance of the resulting coil at an angle of 0° was 11 millihenries, and the electrical Q at 10 kcps was 3.5.

The instrument was connected to a Bendix TOL-5B inductance oscillator by using the instrument inductance as half of the Hartley oscillator coil and a 10-millihenry choke as the other half. Although the oscillator would not operate below about 8 kcps with this arrangement, operation above that frequency was satisfactory. A calibration curve of frequency against angle using a center frequency of 10.5 kcps is shown in figure 9.

Use of magnetic components specifically suited to audio frequencies would probably result in an instrument usable over most of the channel frequencies of the FM-FM telemetering system.

CORRECTIONS AND PRECAUTIONS IN USE

Pitching Velocity Corrections

In most installations the flow-direction indicator is located well forward of the model in order to minimize errors due to the flow field around the model. Since it is usually desired to refer aerodynamic coefficients to the model center of gravity, it is necessary to correct the reading at the pickup location for induced flow due to the pitching velocity of the model and the curvature of its flight path.

The corrected angle of attack at the center of gravity of the model is given to a good approximation by the equation:

$$\alpha_{cg} = \alpha_i + \frac{X}{V} \dot{\theta} \quad (2)$$

Substituting the quantities usually available for determining $\dot{\theta}$, equation (2) becomes

$$\alpha_{cg} = \alpha_i + \frac{X}{V} \left[\frac{360g}{2\pi} \left(\frac{A_n - \cos \theta \cos \phi}{V} \right) + \frac{d\alpha_i}{dt} \right] \quad (3)$$

where

- α_{cg} angle of attack at center of gravity of the model, deg
- α_i angle of attack at pickup, deg
- X distance between aerodynamic center of vane and center of gravity of model, positive when vane is ahead of center of gravity, ft
- V velocity, ft/sec
- A_n normal acceleration at center of gravity of model, g
- g acceleration of gravity, ft/sec²
- θ angle between longitudinal axis of model and horizontal

$$\dot{\theta} = \frac{d\theta}{dt}$$

ϕ roll angle of model with respect to horizontal

$d\alpha_1/dt$ indicated rate of angle of attack about center of gravity, deg/sec

Because $\cos \theta \cos \phi$ cannot exceed 1.0, whereas A_n is often much greater than 1.0, and V is generally greater than 600, it is often assumed that $\frac{\cos \theta \cos \phi}{V}$ is small enough to be neglected, and the angle of attack at the center of gravity is approximately

$$\alpha_{cg} = \alpha_1 + \frac{X}{V} \left(\frac{360g}{2\pi} \frac{A_n}{V} + \frac{d\alpha_1}{dt} \right) \quad (4)$$

In a typical model having $X = 4$ ft, $V = 1000$ ft/sec, and oscillating sinusoidally in pitch at 2.5 cps with peak $A_n = \pm 5g$ and peak $\alpha_1 = \pm 2^\circ$, the correction for pitching velocity and flight-path curvature is a maximum of 0.13° at $\alpha_1 = 0^\circ$.

Frequency Response

Because the damping of this instrument is primarily aerodynamic and the spring force is entirely aerodynamic, its response is not a function of the indicated angle, that is, the relative angle between the sting and the vanes, but rather is a function of the angle of the head in space. The significance of this relationship in determining the dynamic response can readily be seen by considering two possible sets of conditions of an instrument mounted in a wind tunnel. For the first condition, the instrument is in a tunnel in which the air flow direction is constant but the sting is mounted to a device which changes the sting angle in the tunnel without changing the location of the pivoting axis of the instrument. For the second condition, the sting angle is fixed but the direction of air flow is variable. In both cases, there will be rotation between the sting and the head and an indication of changing angle. In the first case, however, there is no rotation of the head and no change in the aerodynamic forces on the head. Therefore, since the friction and damping forces between the head and the sting are negligible, the angle of the sting with respect to flow direction is indicated with proper amplitude and no lag, regardless of the frequency of operation. In the second case, any change in the relative angle between sting and head requires rotation of the head and changes in the aerodynamic forces acting on it. In this case, the indication of the angle between the sting and the flow direction is subject to amplitude and phase errors depending on the natural frequency and aerodynamic damping of the head.

The action of the instrument when mounted on a model in free flight falls between the two extremes discussed above. The head assumes the angle of its flight path in space, which can be approximated by the following equation:

$$\psi_h = \frac{360g}{2\pi} \int \frac{A_n - \cos \theta \cos \phi}{V} dt + \frac{X}{V} \left[\frac{360g}{2\pi} \left(\frac{A_n - \cos \theta \cos \phi}{V} \right) + \frac{d\alpha_1}{dt} \right] \quad (5)$$

The first term of this equation is the flight-path angle of the model center of gravity; the second term corrects this for the location of the pickup. As in equation (3), the term $\frac{\cos \theta \cos \phi}{V}$ may generally be ignored.

If the same values used in the example following equation (4) are substituted into equation (5), rotation of the head in space is found to be $\pm 0.46^\circ$ which is less than one-fourth of the indicated-angle-of-attack range. If the other factors are kept constant but the frequency of oscillation is varied, the head is found to rotate only $\pm 0.06^\circ$ at a frequency of 5 cps and $\pm 0.35^\circ$ when the frequency is 10 cps. Rotation of the head in space will vary with all factors involved but under practically all conditions the amplitude of head rotation is considerably less than the amplitude of the indicated angle of attack.

The characteristics of the models on which the dual-flow-direction pickup are used are such that the natural frequency of the models will not exceed about 10 percent of the natural frequency of the pickup. Thus, although the pickup has a damping coefficient of only about 5 percent of the critical value, its amplitude and phase errors are very small. The pickup response calculated under the assumption that it is being operated at 10 percent of its natural frequency indicates that there will be an amplitude error of only 1 percent and a phase lag of only 0.6° . However, since the actual head rotation has been shown to be less than the range of indicated angle of attack, amplitude errors and apparent phase lag will be less than calculated. Therefore, when the pickup is used, it is assumed to indicate the true local flow direction; amplitude and phase errors in the recorded data are due to the response of the ground recording system, which can be measured and corrected for, when necessary.

IMPROVED SINGLE-AXIS FLOW-DIRECTION PICKUP

Work which was carried out in making a satisfactory dual-flow-direction pickup also made possible the design of a single-axis flow-direction pickup which is smaller in size and more reliably constructed than the one described in reference 1. This instrument, which is used on models where the size of the dual-flow-direction instrument is objectionable or where only one measurement is necessary, simply eliminates one pair of vanes and the associated rotational axis and sensing element of the dual pickup; thus, a 30-percent reduction in its size is possible. The single-axis pickup has characteristics which are the same as those of the pickup described in this report, with the exception that the natural frequency is about 35 percent higher.

CONCLUDING REMARKS

In use, the dual-flow-direction pickup described above has provided satisfactory data from pilotless aircraft operating at Mach numbers from 0.5 to 2.8 and dynamic pressures up to 65 psi. Test results indicate that satisfactory operation can be expected at higher Mach numbers and dynamic pressures, with the limitation that errors in reading absolute angles may become excessive due to aerodynamic heating if the flight time is long.

The inductance pickoff of the instrument was designed for use on the 100 to 200 kcps subcarrier frequencies of the NACA FM-AM telemetering system. Satisfactory operation, however, has also been obtained on the higher subcarrier frequencies of the Research and Development Board standard FM-FM telemetering system.

Characteristics of the instrument may be summarized as follows:

(1) Using only a protractor calibration, the accuracy of the instrument under most conditions is better than 0.2° . Resolution is not limited by the instrument. Particular characteristics effecting the accuracy are as follows: The aerodynamic "zero" agrees with protractor calibration zero to within less than 0.2° . Acceleration errors are less than 0.01° per g when dynamic pressure exceeds 2.7 psi; the instrument withstands shock and static accelerations up to 100 g without damage. The instrument has been used with satisfactory accuracy and stability at Mach numbers from 0.5 to 2.8 and at dynamic pressures up to 65 psi.

(2) The dynamic response is adequate for use on any model large enough for the instrument size to be reasonable. Damping coefficient is approximately 5 percent of critical; the natural frequency at Mach number 1.0 at sea level is 135 cps.

(3) The over-all exposed length is 7 inches; the frontal area is approximately 1 square inch; and the total weight is 0.32 pound.

(4) The instrument is mounted forward of the aircraft.

(5) Flow direction angles with respect to the instrument mounting axis of up to 15° in any direction can be measured. The instrument has been used satisfactorily with calibrated ranges as small as 8° .

(6) Separate variable inductance outputs are provided for indication of local angle of attack and angle of sideslip; there is no interaction between the two quantities. Inductance variation is approximately 1.5 percent per degree of angle.

(7) Static-temperature errors with a calibrated range of 20° are between 0.1° and 0.3° for a temperature change of 100° F. A sudden rise of head temperature of about 320° F above ambient produces an initial drift of approximately 0.2° per minute.

(8) Calibration is direct and simple and the construction costs are relatively low.

Langley Aeronautical Laboratory,
National Advisory Committee for Aeronautics,
Langley Field, Va., November 5, 1953.

APPENDIX

METHOD OF ANALYSIS

In order to simplify evaluation of the performance of the instrument described herein, the assumption was made that at a given Mach number the aerodynamic forces and moments vary linearly with α_h and $\dot{\alpha}_h$, the angle and rate of change of the angle between the head axis and the relative wind. The instrument can then be represented as a simple mass-spring-damper system, in which mass is equivalent to the moment of inertia of the head and attached moving parts, the spring is the aerodynamic moment tending to "zero" the head with the relative wind, and the damping is the sum of the aerodynamic and mechanical damping forces on the head movement. Analyses of the behavior of such systems can be found in standard reference books such as reference 8. The natural frequency and damping coefficients of such devices are related to the instrument parameters as follows:

$$f_n = \frac{1}{2\pi} \sqrt{\frac{57.3k}{I}} \tag{6}$$

$$\delta = 100 \frac{\lambda}{2\sqrt{57.3kI}} \tag{7}$$

where

- f_n natural frequency, cps
- δ damping coefficient, percent critical
- k spring constant, in-lb/deg
- I moment of inertia, in-lb-sec²
- λ damping factor, in-lb/radian/sec

If any mechanical damping forces which may be present are assumed to be negligible, the equation of angular motion of the pickup head may be written in general terms as follows:

$$I\ddot{\alpha}_h + \dot{\alpha}_h (C_{m\dot{\alpha}_h} q_c S l^2) + \alpha_h (C_{m\alpha_h} q_c S l) = 0 \tag{8}$$

where

$C_{m\dot{\alpha}_h}$ damping-moment coefficient, $\frac{\text{Damping moment}}{\dot{\alpha}_h q_c S l^2}$

$C_{m\alpha_h}$ pitching-moment coefficient, $\frac{\text{Pitching moment}}{\alpha_h q_c S l}$

q_c free-stream dynamic pressure

S representative surface area

l representative linear dimension

α_h head angle with respect to relative wind

$$\dot{\alpha}_h = \frac{d\alpha_h}{dt}$$

$$\ddot{\alpha}_h = \frac{d^2\alpha_h}{dt^2}$$

The first and second terms in parentheses in equation (8) are equivalent to λ , the damping factor, and k , the spring constant, respectively, in equations (6) and (7). At a given Mach number, the coefficients $C_{m\dot{\alpha}_h}$ and $C_{m\alpha_h}$ are constants, and the terms S and l are constants for a given configuration. It can be seen from equation (8), however, that the damping coefficient and the spring constant are directly proportional to q_c , the free-stream dynamic pressure. At a given Mach number, q_c is directly proportional to the free-stream static pressure (ref. 9). Therefore, from equations (6) and (7), it can be seen that, at a given Mach number, the natural frequency and damping coefficient of the instrument are directly proportional to the square root of the free-stream static pressure. These simple relationships were used in calculating the instrument-performance characteristics at various pressure altitudes from data obtained under the tunnel test conditions.

REFERENCES

1. Mitchell, Jesse L., and Peck, Robert F.: An NACA Vane-Type Angle-of-Attack Indicator for Use at Subsonic and Supersonic Speeds. NACA TN 3441, 1955. (Supersedes NACA RM L9F28a.)
2. Cooper, Morton, and Webster, Robert A.: The Use of an Uncalibrated Cone for Determination of Flow Angles and Mach Numbers at Supersonic Speeds. NACA TN 2190, 1951.
3. Fieldgate, Ivan O.: Airstream Direction Detector-Type D. Memo. Rep. MR-135, Specialties, Inc. (Syosset, N. Y.), Mar. 7, 1949.
4. Young, D. W.: The Measurement of Angle of Attack and Angle of Yaw in Flight. Tech. Data Digest (Central Air Documents Office), vol. 15, no. 11, Nov. 1950, pp. 23-30.
5. Keith, Melvin: Consideration of a Wedge-Shaped Vane As an Air Flow Direction Measuring Instrument for Aircraft Fire Control Purposes. NOTS Tech. Memo. No. 154, U. S. Naval Ordnance Test Station (China Lake, Calif.), Sept. 11, 1951.
6. Dorrance, William H.: Nonsteady Supersonic Flow About Pointed Bodies of Revolution. Jour. Aero. Sci., vol. 18, no. 8, Aug. 1951, pp. 505-511, 542.
7. Anon.: Nomenclature for Aeronautics. NACA Rep. 474, 1941.
8. Den Hartog, J. P.: Mechanical Vibrations. Third ed., McGraw-Hill Book Co., Inc., 1947.
9. Burcher, Marie A.: Compressible Flow Tables for Air. NACA TN 1592, 1948.

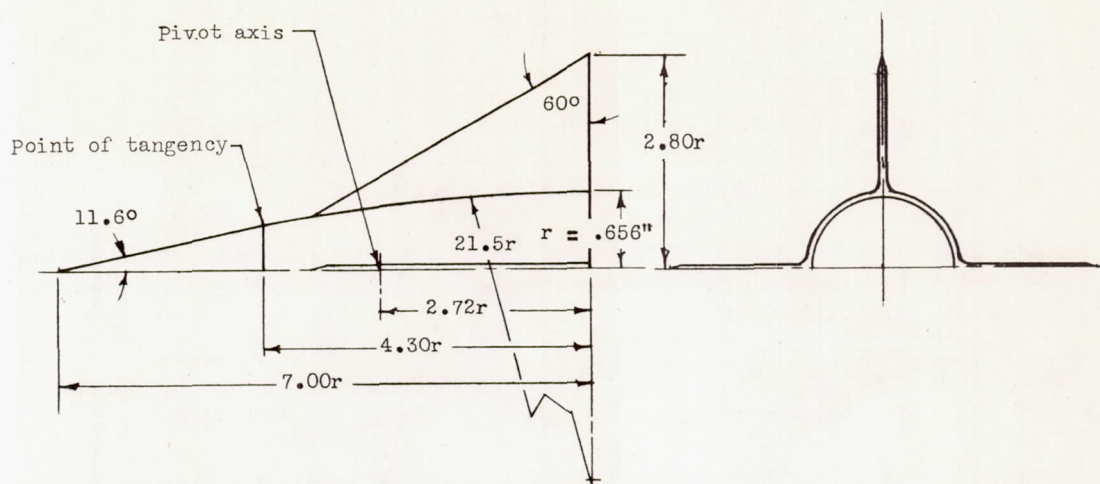

(a) Original head configuration.

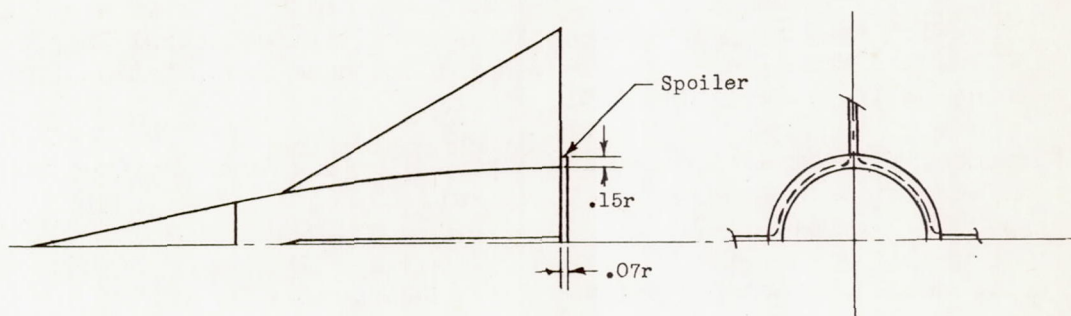

(b) Spoiler modification to original head.

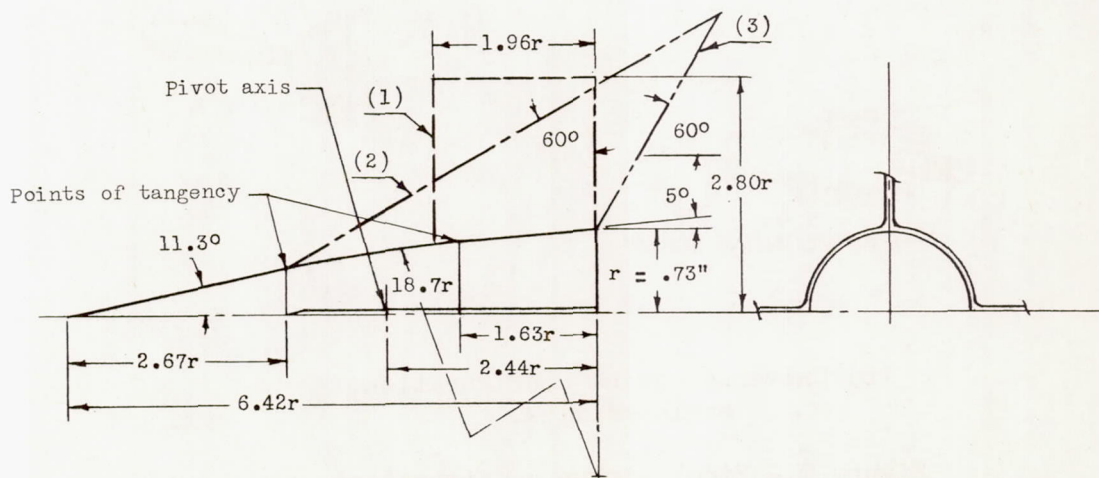

(c) Three vane configurations using same body shape.

Figure 1.- Head designs.

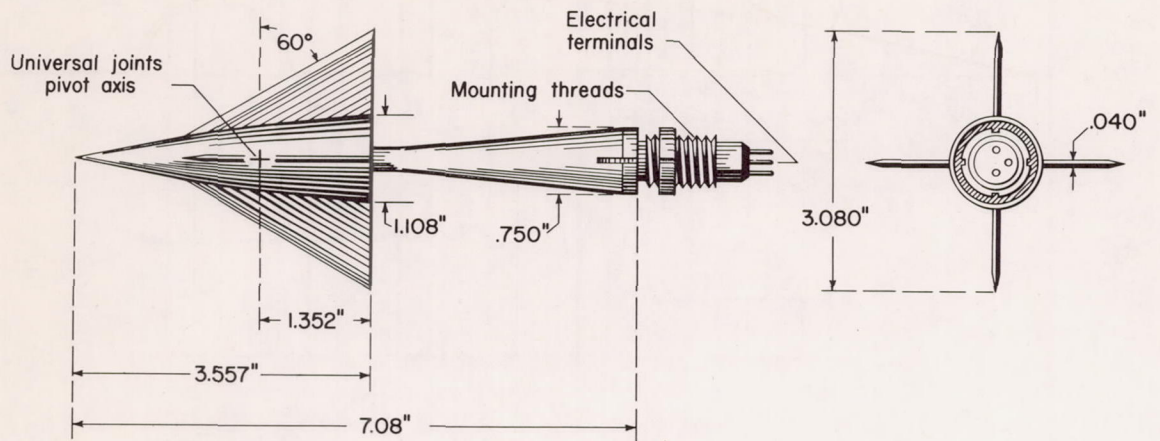

(a) External configuration.

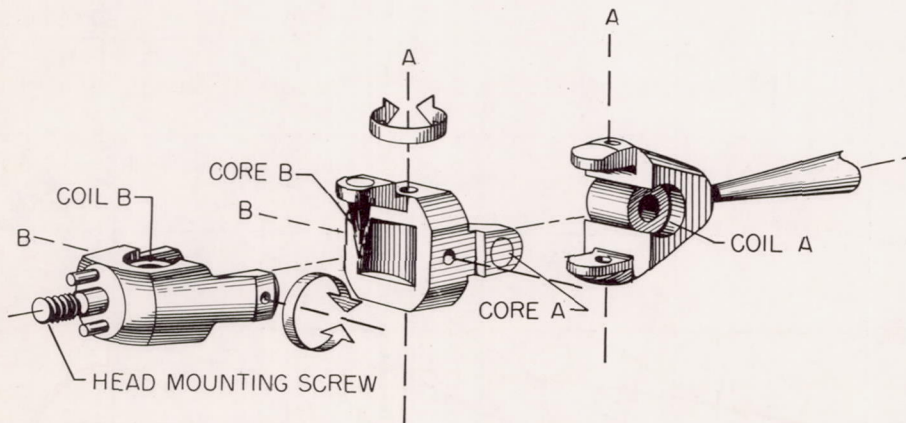

(b) Universal joint configuration,
exploded view.

Figure 2.- Final pickup configuration.

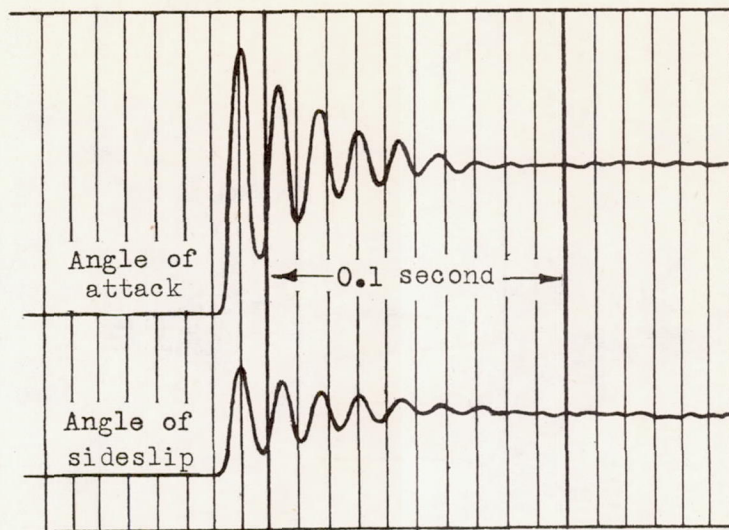

Figure 3.- Damping record obtained in Langley high-speed 7- by 10-foot tunnel. Mach number, 0.8; static pressure, 9.58 psi.

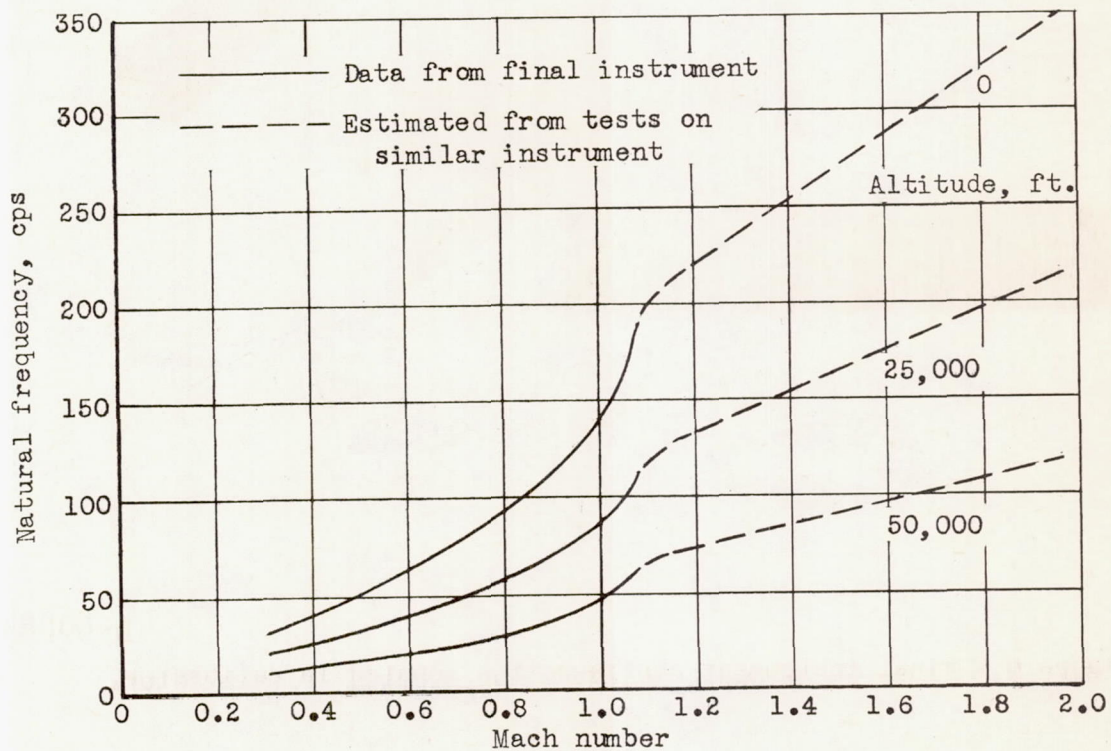
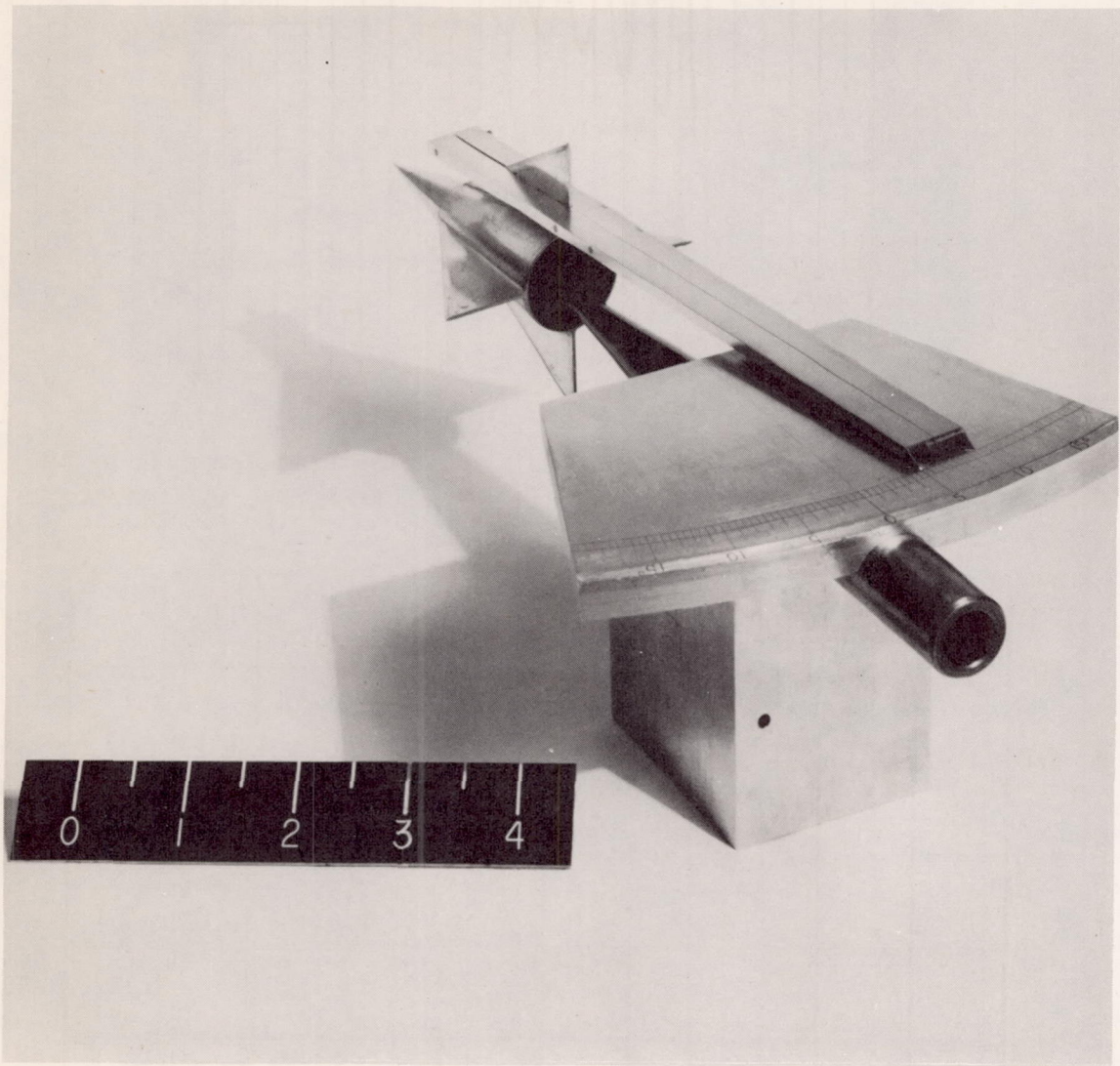
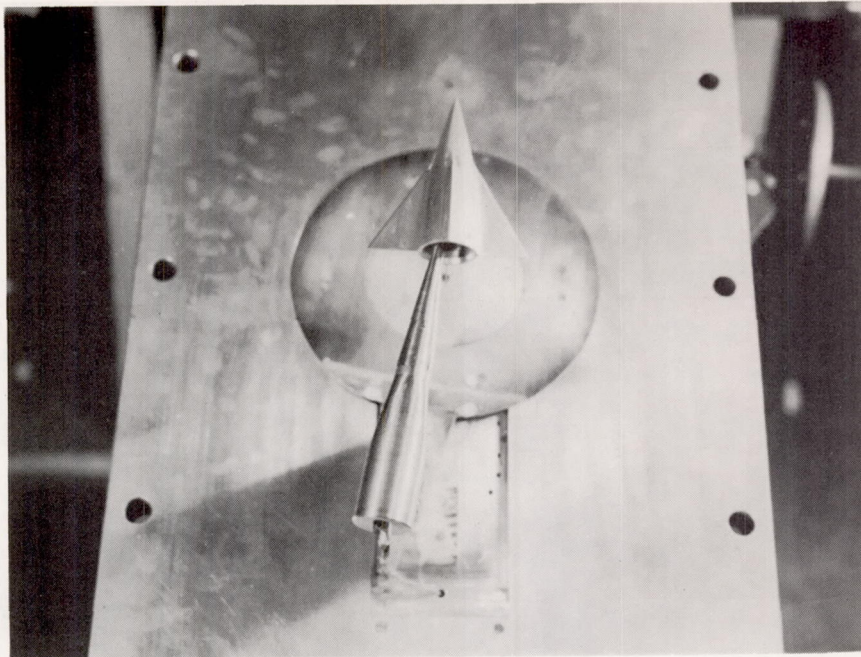

Figure 4.- Plot of natural frequency against Mach number at different altitudes.



L-80883

Figure 5.- Final instrument configuration mounted in calibrator.



L-82057

Figure 6.- Instrument configuration of fig. 2(a), mounted in Langley 9- by 12-inch supersonic blowdown tunnel for angular calibrations.

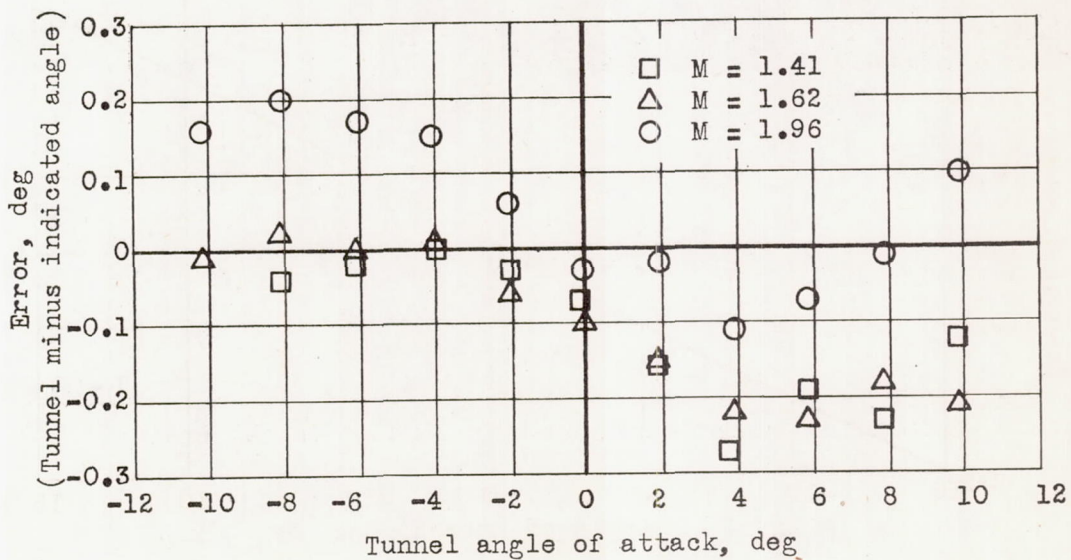

Figure 7.- Wind-tunnel check of protractor calibration at the three test Mach numbers.

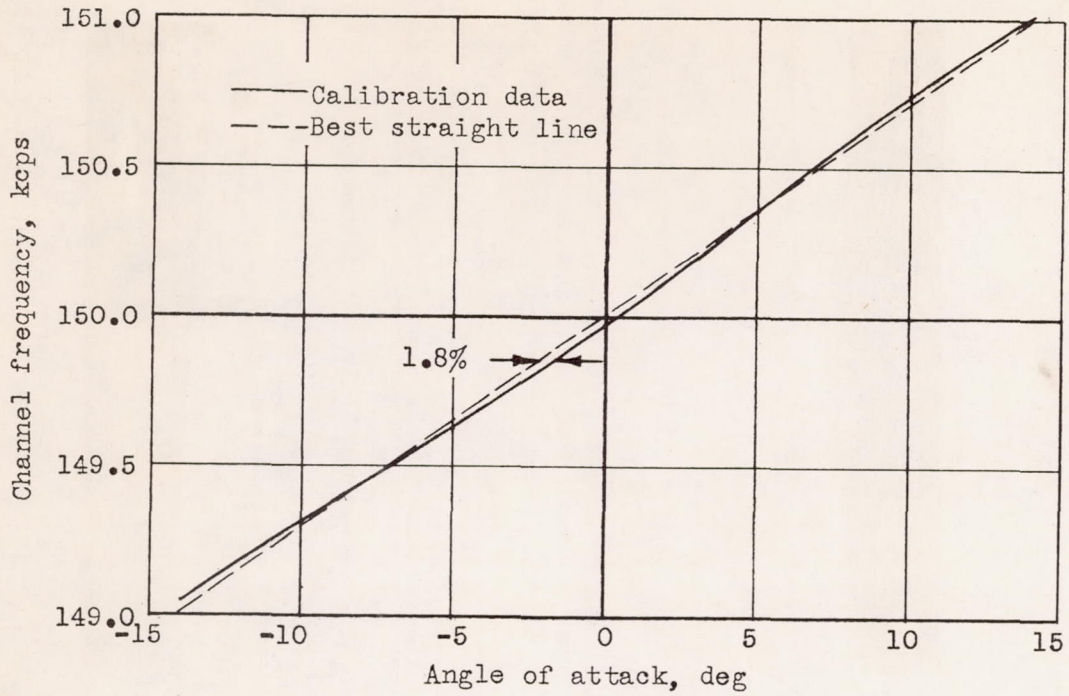

Figure 8.- Calibration on 150-kilocycle channel.

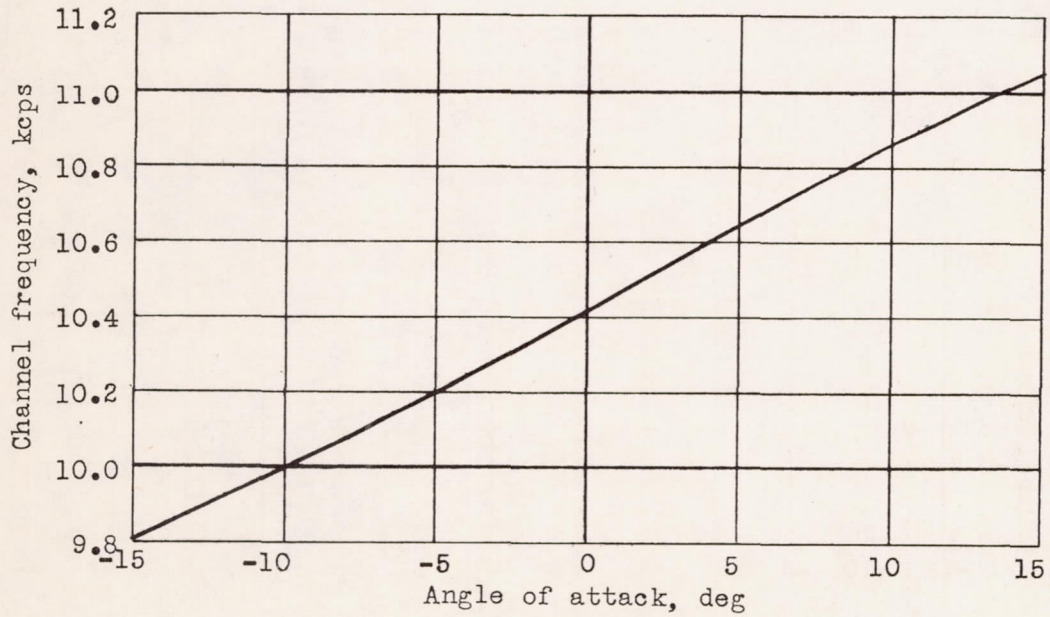

Figure 9.- Calibration on 10-kilocycle audio channel.