

NACA TN 3835

NACA TN 3835

# NATIONAL ADVISORY COMMITTEE FOR AERONAUTICS

NACA TN 3835

TECHNICAL NOTE 3835

NACA TN 3835

## A STUDY OF SPRAYS FORMED BY TWO IMPINGING JETS

By Marcus F. Heidmann, Richard J. Priem, and Jack C. Humphrey

Lewis Flight Propulsion Laboratory  
Cleveland, Ohio

SECRET



Washington  
March 1957

SECRET

REPRODUCED BY  
NATIONAL TECHNICAL  
INFORMATION SERVICE  
U. S. DEPARTMENT OF COMMERCE  
SPRINGFIELD, VA. 22161

38



## NATIONAL ADVISORY COMMITTEE FOR AERONAUTICS

## TECHNICAL NOTE 3835

## A STUDY OF SPRAYS FORMED BY TWO IMPINGING JETS

By Marcus F. Heidmann, Richard J. Priem, and Jack C. Humphrey

## SUMMARY

The spray formed by two impinging liquid jets was investigated over a jet velocity range of 5 to 100 feet per second to determine the characteristics of this method of atomization. At low velocities the spray pattern was a smooth sheet completely surrounded by a liquid rim. As jet velocity increased, the rim separated at the downstream end. In this flow region an alternate spray pattern with a rippled sheet and periodic drops can occur. At higher jet velocities a fully developed spray was produced which was characterized by waves of drops. The wave pattern was more distinct with high-viscosity fluids. The frequency of the waves in the fully developed spray increased with increased injection velocity and decreasing impingement angle. Jet diameter and length before impingement had a negligible effect on the wave frequency. Characteristics of single jets were the same as determined by other investigators.

## INTRODUCTION

Discontinuities or variations in the flow of atomized propellants in rocket engines are of interest because of their possible effect on the combustion process. Although impinging two or more liquid jets is a common method for propellant atomization, such atomization has been demonstrated to be intermittent in nature, thus the instantaneous mass-flow rate at any point after disintegration is not constant. References 1 to 3 indicate that the disintegration of single liquid jets or sheets is intermittent in nature. The purpose of the present investigation was to learn more of the nature of intermittent disintegration of a spray formed by two impinging liquid jets.

The early part of the present study involved the use of water only, and the initial results obtained were published in reference 4. The earlier work, which was confirmed by later and more refined experiments, and the results relating the effects on spray characteristics of liquid viscosity and surface tension have now been combined in the present report in order to provide complete coverage. Reference 4 (Technical Note 2349) therefore is now obsolete and should be discarded.

## APPARATUS AND INSTRUMENTATION

Experiments were performed with an impinging-jet apparatus schematically shown in figure 1(a). Parameters that were variable with this apparatus were: liquid flow rate, impingement angle, jet diameter, and jet length before impingement. Flow rates were the same for both jets in all experiments. The flow rate was controlled by regulating the supply-tank pressure. Rotameter readings and pressure-flow calibrations were used to establish the flow rate. The liquid jets were formed with 2-inch lengths of precision-bore glass tubing of 0.025-, 0.040-, and 0.051-inch inside diameter. These inside diameters and the measured flow rates were used to calculate the jet velocities. High-speed motion pictures of the jet flow confirmed the calculated jet velocity.

The photographic apparatus is shown schematically in figure 1(b). Both high-speed motion pictures (3000 frames/sec) and single-exposure microflash photographs of approximately 4-microsecond exposure were taken of the sprays.

The photoelectric apparatus shown in figure 1(c) was used to study the intermittent or periodic disintegration which is characteristic of a spray formed by impinging jets. Photographs of a typical spray are shown in figure 2. The photographs show groups of drops which appear as waves propagating from the point of impingement. These groups of drops interrupted a beam of light entering the photoelectric cell. The output from the photoelectric cell was analyzed with a pulse meter and an oscilloscope as shown in figure 1(c). The beam of light, 1/4 by 1/8 inch, was orientated with respect to the spray as shown in figure 2. The distance from the point of jet impingement was adjusted for each spray until a distinct, large-amplitude oscillation was observed on the oscilloscope. A direct reading of the number of pulses per second was then made with the pulse meter. It was assumed that each pulse represented one wave of drops in the spray pattern.

The amplitude of the pulses was not the same for all groups of drops, as is shown by the typical oscilloscope trace in figure 3. Apparently the large and more distinct groups of drops produced the largest amplitude pulses. The pulses were normally distributed about the mean pulse amplitude. Because of the randomness of the signal observed on the oscilloscope, the wave counts obtained from the pulse meter were checked in several ways. A direct count was made of the pulses on several oscilloscope records. All inflection points in the signal were considered. The pulse rate calculated by this method was from 5 to 10 percent higher than the meter reading. Wave counts were also made from high-speed motion pictures of the spray (fig. 4). The wave frequency obtained by this method agreed more closely with the pulse meter reading. For convenience, the pulse meter reading was used for all values reported herein.

## EXPERIMENTAL RESULTS

## Spray Patterns

Several types of spray patterns were observed and are identified in figure 5(a). All the spray patterns are flat and in a plane perpendicular to that of the two impinging jets, as shown in figure 2.

Closed rim. - The closed-rim pattern has a smooth liquid sheet which is perpendicular to the plane formed by the two jets (fig. 5(a)). A liquid rim outlines the sheet and contains the major portion of the liquid flow. The rims impinge at the downstream end of the sheet and eventually form a single stream which breaks up into drops.

Periodic drop. - The periodic-drop pattern has a liquid sheet which is rippled to form a wave pattern. Regularly spaced drops are thrown off tangentially from the periphery of the main sheet. The amount of liquid flow in these drops is small compared to the flow in the main section, but the velocities are equal.

Open rim. - The open-rim pattern is similar to the closed-rim pattern except that the rims do not impinge. The liquid sheet decreases in thickness as it progresses from the point of jet impingement and eventually disintegrates. The breakup of the rim appears to be similar to the breakup of a single jet, that is, it is first ruffled and eventually breaks up into ligaments and drops.

Fully developed. - All spray patterns that show waves of drops which appear to project from the point of jet impingement are defined as fully developed sprays. This pattern may also have lines of regularly spaced drops and a rippled sheet. These additional characteristics were not always present in this pattern.

## Velocity Range

In figure 5(b) the spray patterns of a 70-percent-glycerol solution are given for various jet velocities. Low-velocity jets produced the closed-rim pattern. As the jet velocity increased, the sheet increased in size until the rim separated at the downstream side (characteristic of the open-rim pattern). This separation first occurred at about 20 feet per second and between 20 and 30 feet per second the separation increased with velocity. The periodic-drop pattern may occur at velocities as low as 15 feet per second. The periodic-drop pattern and the closed- or open-rim pattern can all occur in the region between 15 and 30 feet per second. At velocities greater than 30 feet per second, the spray was fully developed.

The transition which occurs between the open-rim and fully developed sprays can occur abruptly with no apparent external influence. A succession of high-speed motion picture frames which show the transition is reproduced in figure 6. The transition can occur in either direction.

#### Effect of Fluid Properties on Spray Pattern

Spray patterns formed with various liquids at room temperature were studied. The surface tensions and viscosities of these liquids at 20° C are given in the following table:

Liquid	Viscosity, centipoises	Surface tension, dynes/cm
70-Percent-glycerol solution (by volume)	32.7	67.2
64-Percent-glycerol solution (by volume)	18.7	67.9
54-Percent-glycerol solution (by volume)	8.7	69.1
40-Percent-glycerol solution (by volume)	4.26	70.5
Varsol	1.50	30.0
Water	1.005	73.05

Periodic-drop and fully developed spray patterns obtained with these liquids are shown in figure 7. The viscosity varied over a range of about 30 to 1. In both spray patterns the periodic phenomena appeared pronounced with high-viscosity liquids. The surface tensions of all the liquids except varsol are similar. Surface tension was reduced by about one-half with varsol, but no pronounced effect is evident in the spray photographs.

The effect of fluid properties on the width of the liquid sheet for all spray patterns is shown as a function of jet velocity in figure 8. The sheet width was measured at its maximum dimension from spray photographs. The width increased with velocity until the fully developed spray was produced. A reduction in width then occurred. Prior to this reduction, sheet width was slightly larger with high-viscosity liquids.

The length of the liquid sheet for various fluids is shown as a function of jet velocity in figure 9. The length of the sheet was taken to the point where the sheet broke up into drops or ligaments. Initially the length increased rapidly with velocity. This corresponds to the velocity region where the closed-rim and periodic-drop patterns were formed. The length asymptotically approached a constant value when the rim parted on the downstream end. For a given velocity a high-viscosity

or a low-surface-tension fluid gave a longer spray sheet. The length of the fully developed spray could not be determined.

Functions of viscosity and surface tension that produced the best correlation for the data were empirically evaluated. The correlation shown in figure 10 is an attempt to generalize the results so that spray lengths for other liquids may be predicted.

#### Effects of Jet Velocity and Geometry on Fully Developed Sprays

The fully developed spray pattern was further investigated by changing jet velocity, impingement angle, diameter of jets, and impingement distance. In these studies the frequency of occurrence (wave frequency) of the waves of drops propagating from the point of impingement was measured with the photoelectric cell and pulse counter.

Jet velocity. - The effect of jet velocity on wave frequency is shown in figure 11. Wave frequency increased almost linearly with velocity, with an average slope of approximately 30 waves per second for each foot per second of velocity. The wave-frequency - velocity relation was similar for all impingement angles. The variation in the spray pattern resulting from changes in jet velocity is shown in figure 12. Views perpendicular as well as parallel to the plane of the jets are shown. These photographs illustrate that the wave pattern was not substantially altered by jet velocity. Smaller drops were formed, however, at the higher velocities.

Impingement angle. - The variation in wave frequency as a function of impingement angle and the resultant jet velocity in the plane of the spray are shown in figure 13 for a constant jet velocity of 40 feet per second. For impingement angles between  $50^\circ$  and  $100^\circ$  the frequency increased linearly with the resultant velocity. The data at small impingement angles were scattered because indistinct waves were produced at small angles.

The spray patterns for impingement angles of  $30^\circ$ ,  $60^\circ$ , and  $90^\circ$  are shown in figure 14. These photographs show more distinct wave formation as well as shorter distances for complete disintegration as impingement angle is increased. The photographs taken perpendicular to the plane of the two jets indicate a greater dispersion of the spray with large impingement angles.

Jet diameter. - The effect of jet diameter on wave frequency is shown in figure 15. The effect of diameter is small, although slightly higher frequencies were obtained with smaller diameter jets. At constant jet velocity the frequencies obtained with the 0.025- and 0.057-inch jets differed by only 200 to 300 waves per second. For a given jet diameter

4140

an equivalent change in flow rate, and hence a change in velocity, resulted in a wave-frequency change of about 2500 waves per second.

The effect of jet diameter on the relation between frequency and impingement angle is shown in figure 16 for a jet velocity of 60 feet per second. The largest variation in frequency with resultant spray velocity was obtained with small jet diameters.

The effect of diameter on the spray pattern is illustrated in the photographs shown in figure 17. Only the size of the resulting spray changed with diameter.

Jet length. - The effect of the length of the jets before impingement on wave frequency is shown in figure 18. The stream length was varied from 6 to 60 jet diameters. The effect over this range is shown to be negligible; a small increase in frequency, however, occurred below a stream length of 30 diameters. The increase amounted to only 4 or 5 percent.

The effect of jet length was more pronounced in the spray pattern than in frequency. Figure 19 portrays this effect for stream lengths of 10, 20, 40, and 60 jet diameters. Dispersion of the spray increased as stream length increased. At a stream length of 60 diameters, the stream began to break up into drops; therefore, it was possible for a portion of the liquid from one jet to pass through the path of the other jet without impinging.

#### SINGLE-JET CHARACTERISTICS

A portion of the investigation was devoted to examining the characteristics of single jets to determine whether spray characteristics observed with the impinging jets were related to flow irregularities in the jets before impingement. Such irregularities might have been caused by cavitation within the orifice, as reported in references 5 and 6. The jet flow calibrations, however, indicated that cavitation was not present.

Photographs of typical single jets of water and a 64-percent-glycerol solution are shown in figure 20 for various jet velocities. The photographs indicate that a solid jet existed for some distance from the end of the tubing. The jet surface eventually became ruffled, however, and drops formed. The extent of surface ruffling increased with jet velocity and decreased with fluid viscosity (glycerol solution compared to water). Smoother jets, therefore, were formed with low Reynolds number flow than with high Reynolds number flow. This agrees with the results of references 2 and 7. The Reynolds number of the flow within the glass tubing varied from 50 to 35,000; therefore, in some of the jets the flow was turbulent. In this flow region a high cross-sectional velocity



gradient existed which ruffled the jets. Since the velocity gradient increased with Reynolds number, ruffling would increase at high velocities or low viscosities.

The drop frequency resulting from the disintegration of a single jet was measured photographically and is shown in figure 21 as a function of jet velocity. The calculated drop frequency based on a wavelength equal to the jet circumference is also shown. The stability criteria of reference 8 state that drop frequency should be no larger than this value. The measured frequency fell within this limit.

### DISCUSSION

The cause of periodic disintegration of fuel sprays is of interest because of its possible effect on combustion. Such disintegration could originate from either unstable equilibrium in the spray or irregularities in the jets prior to impingement.

A condition of unstable equilibrium may occur when external forces tending to spread and reduce the thickness of the liquid sheet are not balanced by the surface tension and viscous forces within the liquid. When a portion of the liquid separates from the main sheet, the balance of these forces is disturbed. An interaction of this nature may cause oscillations and periodic disintegrations.

Irregularities observed in the single jet may also produce a periodic disintegration, since such irregularities would cause the jet momentum to vary continually, and the sheet formed by the two impinging jets would in turn be deflected. The disintegration process of the spray may be controlled by such deflections.

At low Reynolds numbers the periodic disintegrations appear to result from unstable equilibrium in the liquid sheet. Although the surface of a liquid jet is both smooth and unbroken in this flow region, the spray formed by impinging two such jets may have two different patterns, one a smooth liquid sheet with random disintegration and the other a rippled sheet with periodic disintegration. However, since the jet characteristics are the same, it appears unlikely that the periodic disintegration was produced by jet irregularities.

The results obtained with varying jet velocity, impingement angle, and diameter indicate that the fluctuations observed with the fully developed spray could not be dependent on jet irregularities; therefore, they must also be primarily dependent on equilibrium conditions in the sheet. If jet irregularities control the frequency of the fluctuations, the frequency should remain relatively constant with constant-velocity jets and not vary with changes in impingement angle. However, the

frequency did vary with impingement angle, as shown in figure 13. Furthermore, parameters effecting jet irregularities (jet diameter and length before impingement) had a small effect on wave frequency.

In view of the lack of influence of jet irregularities on the frequency of the fluctuations, the intermittent disintegration appears to be dependent on an equilibrium condition within the sheet rather than on irregularities in the jets. Irregularities in the jet and other disturbing forces appear to introduce randomness to the periodic phenomena.

#### SUMMARY OF RESULTS

From the investigation of the spray formed by two impinging jets, the following results were obtained:

1. A spray formed at low velocities was a smooth sheet completely surrounded by a liquid rim. As jet velocity was increased, the rim separated at the downstream end. An alternate spray pattern, with a rippled sheet and periodic disintegration of the sheet and rim, could also form in this flow region. At high jet velocities a fully developed spray was produced, which was characterized by waves of drops.
2. The frequency of the waves in the fully developed spray increased about 30 cycles per second for each foot per second increase in velocity.
3. The frequency of the waves decreased with increasing impingement angle. The frequency correlated with the resultant spray velocity.
4. Changes in jet diameter and length of jet before impingement had small effects on the wave frequency.
5. The spray patterns formed at various jet velocities were similar for all liquids, although high-viscosity liquids produced more distinct patterns.
6. Smoother single jets were formed at low Reynolds number than at high Reynolds number. Frequency of drops produced by single jets increased with jet velocity.

Lewis Flight Propulsion Laboratory  
National Advisory Committee for Aeronautics  
Cleveland, Ohio, October 31, 1956

## REFERENCES

1. Castleman, R. A., Jr.: The Mechanism of Atomization Accompanying Solid Injection. NACA Rep. 440, 1932.
2. Lee, Dana W., and Spenser, Robert C.: Photomicrographic Studies of Fuel Sprays. NACA Rep. 454, 1933.
3. Perry, John H., ed.: Chemical Engineers' Handbook. Second ed., McGraw-Hill Book Co., Inc., 1941, pp. 1983-1984.
4. Heidmann, Marcus F., and Humphrey, Jack C.: Fluctuations in a Spray Formed by Two Impinging Jets. NACA TN 2349, 1951.
5. Randall, L. N.: Rocket Applications of the Cavitating Venturi. Jour. Am. Rocket Soc., vol. 21, no. 1, Jan. 1951, pp. 28-31.
6. Northup, R. P.: An Experimental Investigation of the Flow and Stability of Liquid Streams from Small Orifices Discharging into a Gaseous Atmosphere. Rep. R51A0512, Spec. Proj. Eng. Div., Apparatus Dept., General Electric Co., Feb. 1951. (Proj. Hermes (TUL-2000A.))
7. Haenlein, A.: Disintegration of a Liquid Jet. NACA TN 659, 1932.
8. Rayleigh: On the Instability of Jets. Proc. London Math. Soc., vol. X, Nov. 14, 1878, pp. 4-13.

4140

CQ-2

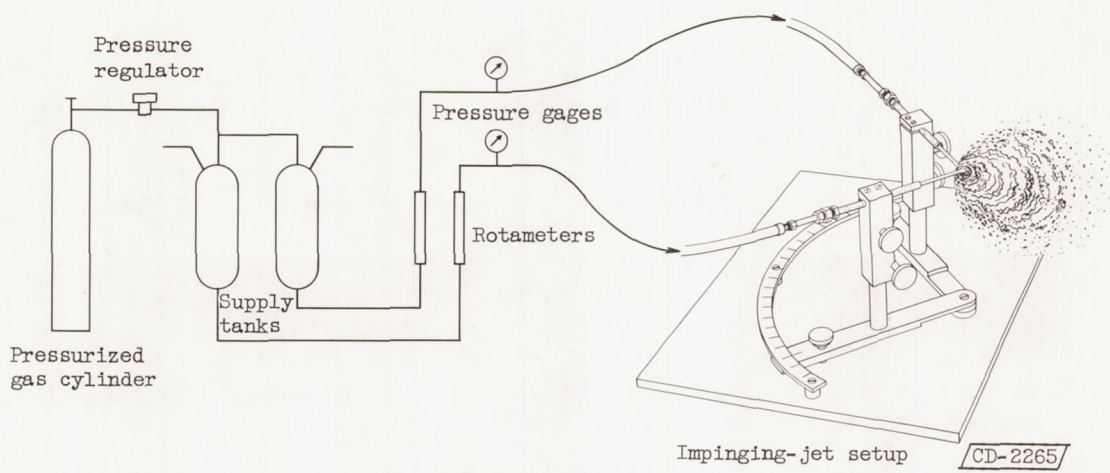

(a) Flow apparatus.

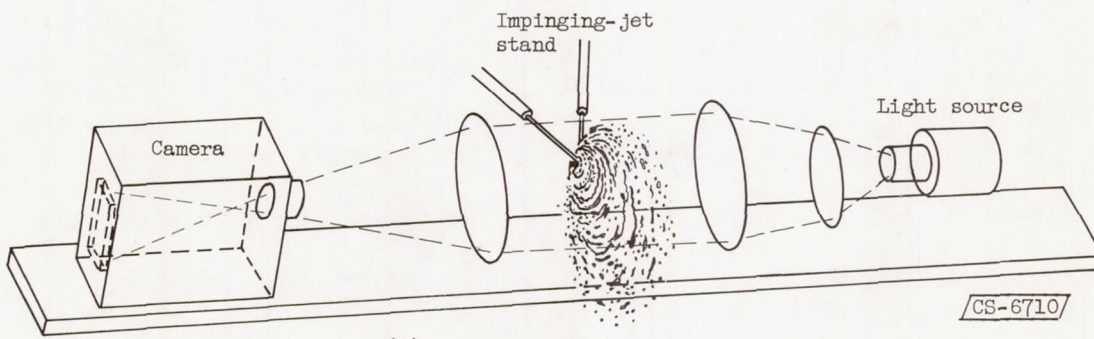

(b) Photographic apparatus.

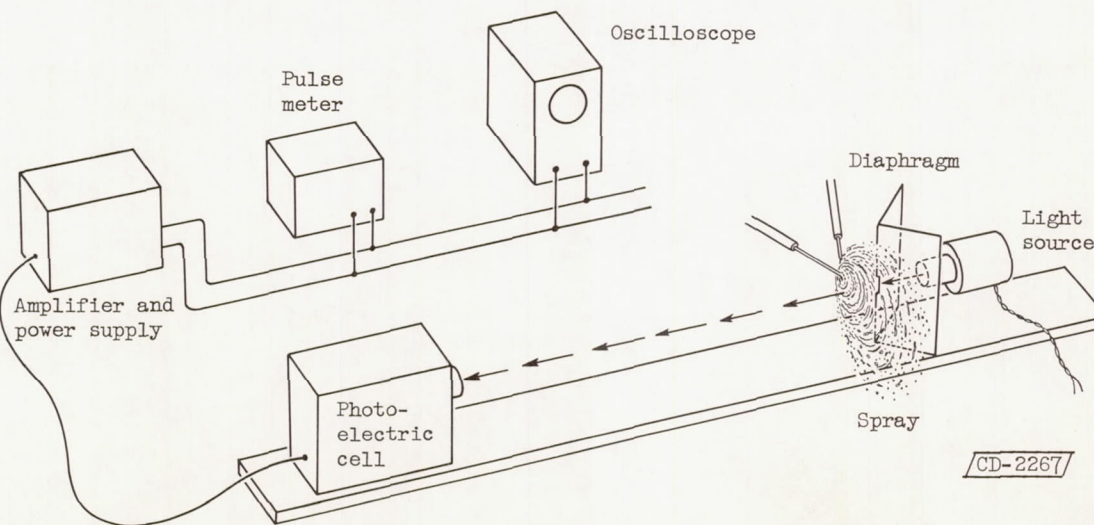

(c) Frequency measurement apparatus.

Figure 1. - Schematic diagram of impinging-jet apparatus and instrumentation.

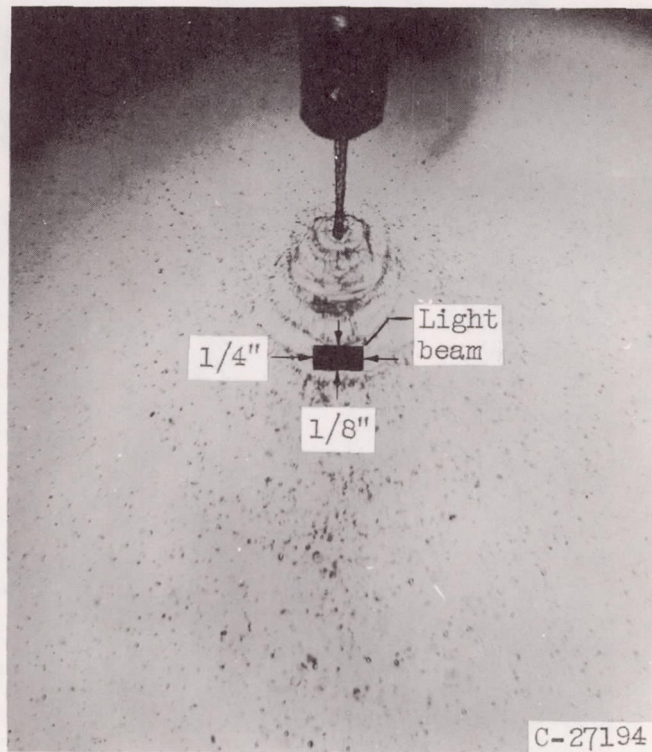
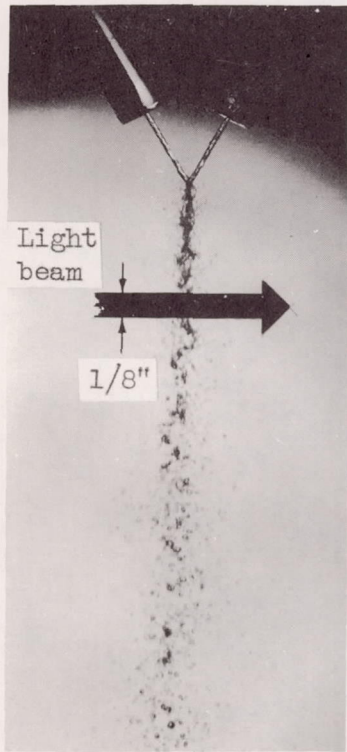

C-27194

Figure 2. - Microflash photographs of spray formed by two impinging jets of water. Views perpendicular and parallel to plane of jets.

4140

CQ-2 back

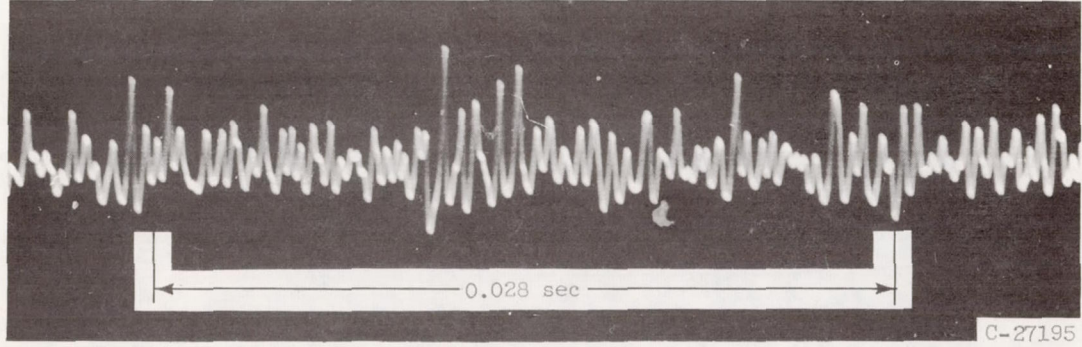

Figure 3. - Oscilloscope trace of photoelectric-cell signal resulting from intermittent disintegration of sheet of liquid formed by two impinging jets.

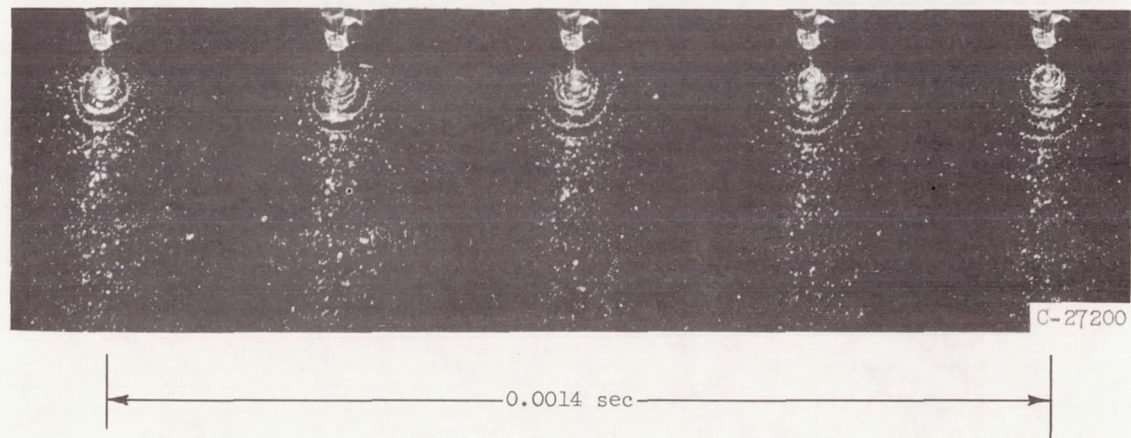
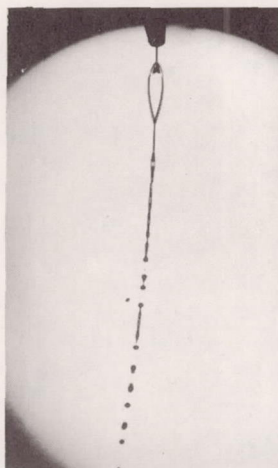
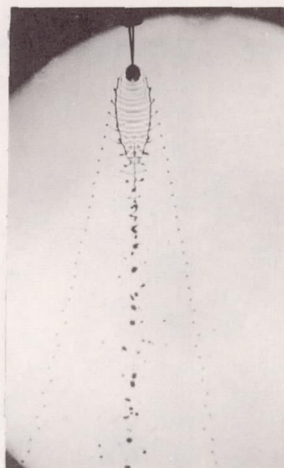

Figure 4. - Successive frames from high-speed motion pictures of formation of spray from two impinging jets of water.

4140



Closed rim



Periodic drop

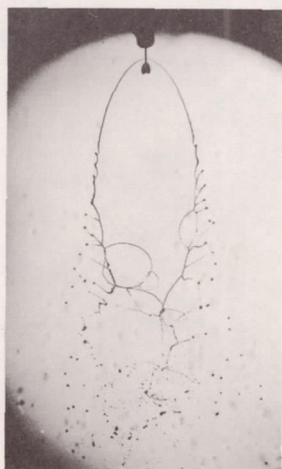

Open rim

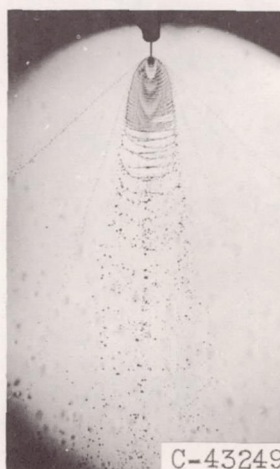

Fully developed (waves)

(a) Typical spray patterns.

Figure 5. - Spray patterns for 70-percent-glycerol solution.  
Impingement angle, 90°; jet diameter, 0.025 inch.

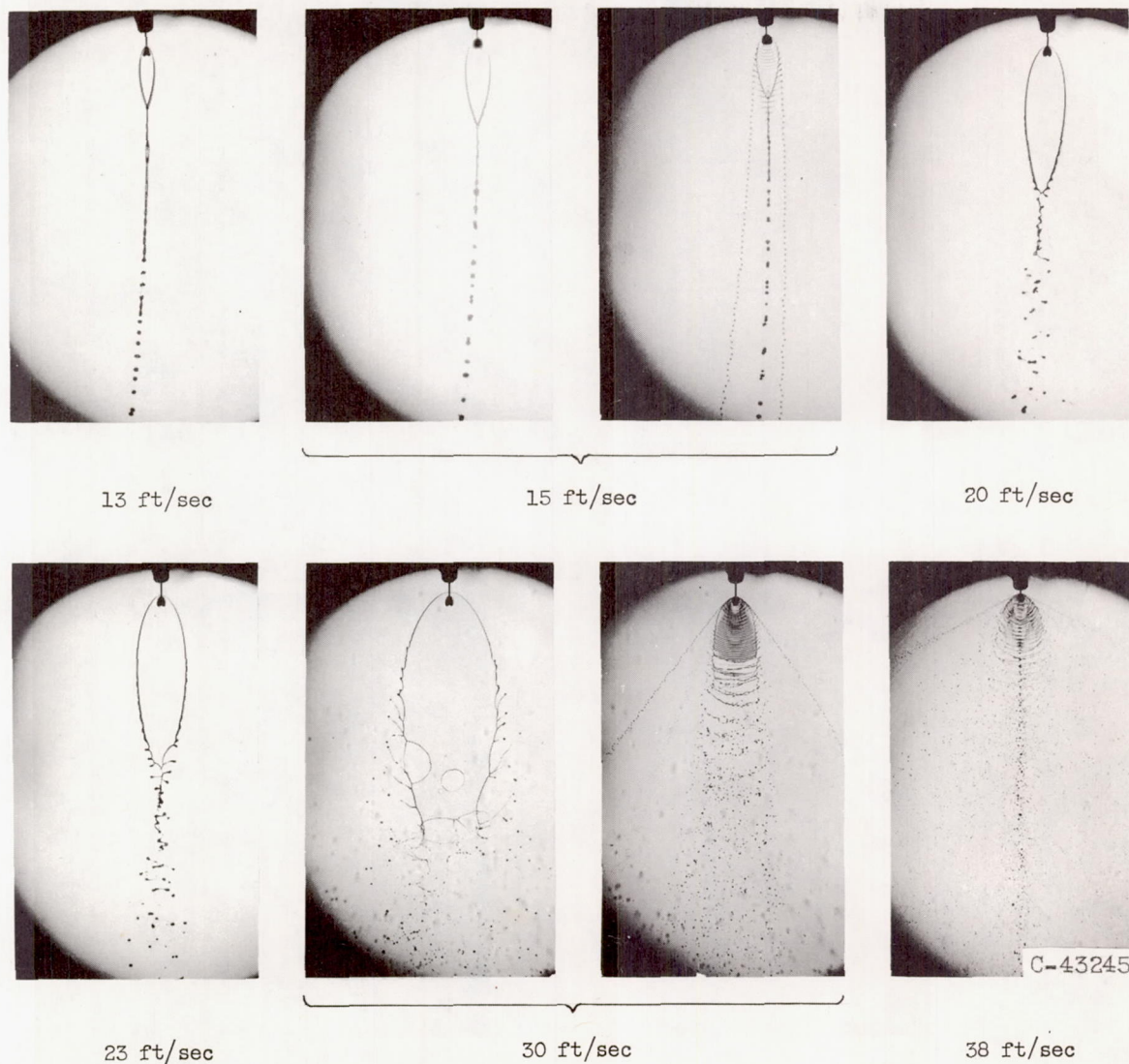

(b) Effect of jet velocity on spray pattern.

Figure 5. - Concluded. Spray patterns for 70-percent-glycerol solution. Impingement angle, 90°; jet diameter, 0.025 inch.



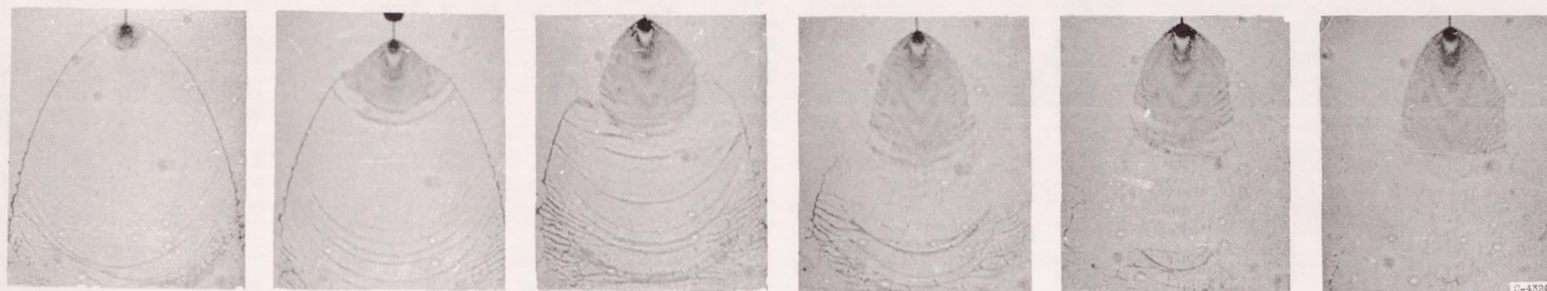

0.0053 sec

Figure 6. - Successive frames of high-speed motion pictures showing transition from smooth-sheet formation to periodic disintegration.

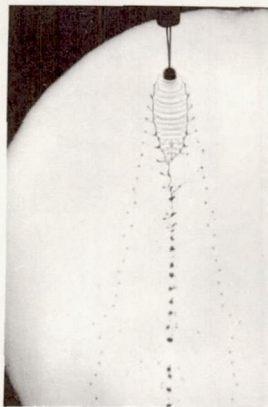

70% Glycerol  
solution

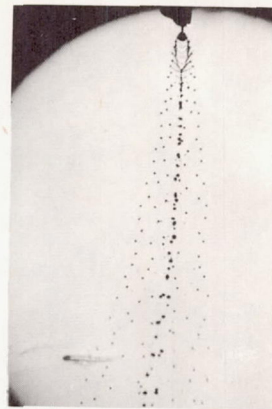

40% Glycerol  
solution

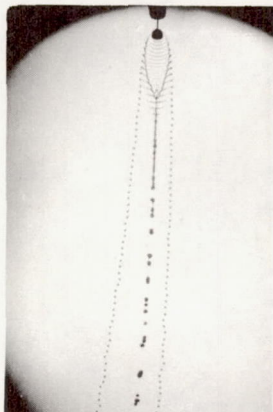

64% Glycerol  
solution

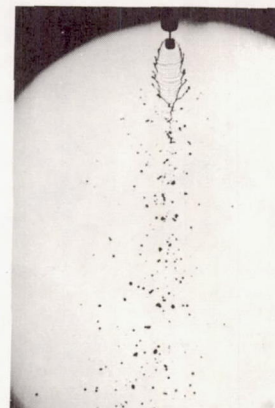

Varsol

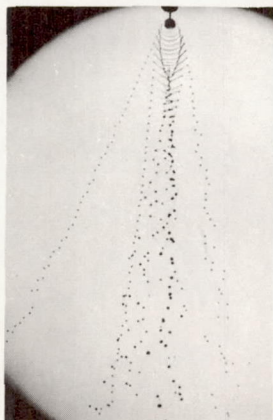

54% Glycerol  
solution

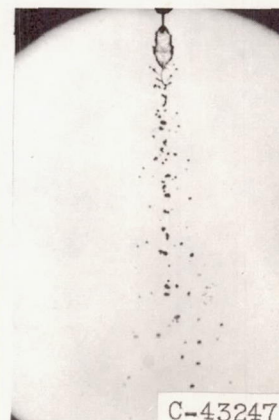

Water

(a) Periodic-drop pattern. Jet velocity, 15 feet per second.

Figure 7. - Effect of fluid on spray-pattern disintegration. Impingement angle,  $90^\circ$ ; jet diameter, 0.025 inch.

4140

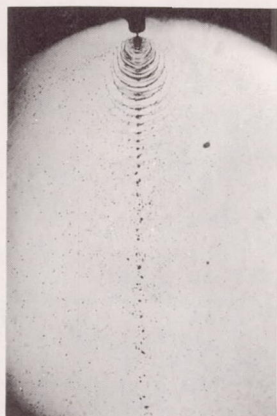

70% Glycerol solution

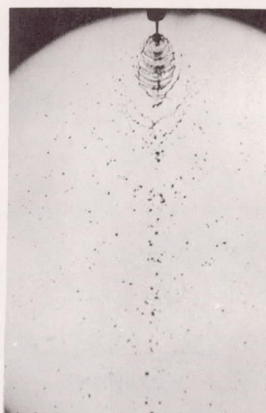

40% Glycerol solution



64% Glycerol solution



Varsol



54% Glycerol solution



Water

(b) Open-rim pattern. Jet velocity, 40 feet per second.

Figure 7. - Concluded. Effect of fluid on spray-pattern disintegration. Impingement angle, 90°; jet diameter, 0.025 inch.

CQ-3

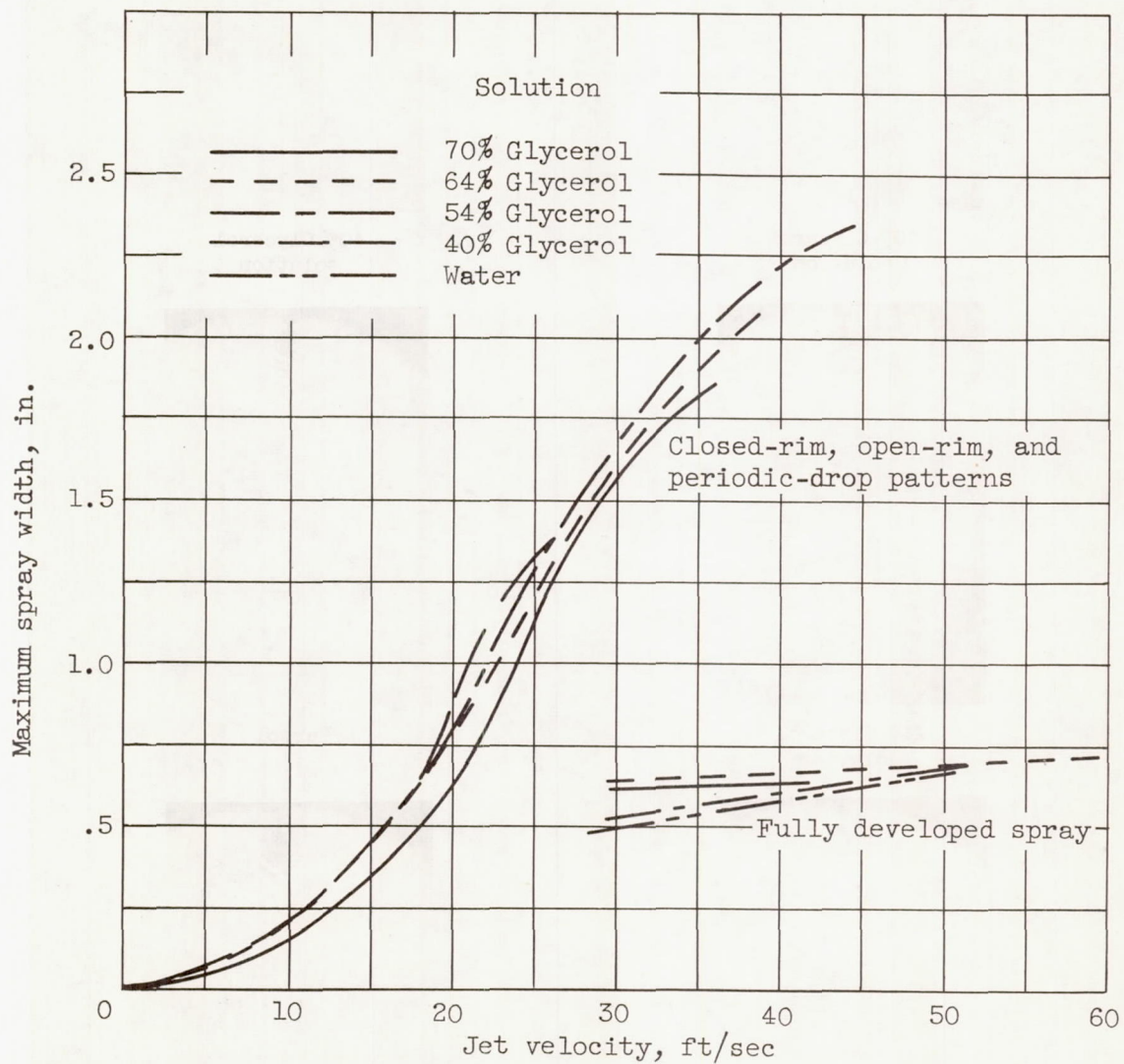

Figure 8. - Effect of jet velocity on maximum width of spray sheet for various fluids. Impingement angle,  $90^\circ$ ; jet diameter, 0.025 inch.

4140

CQ-3 back

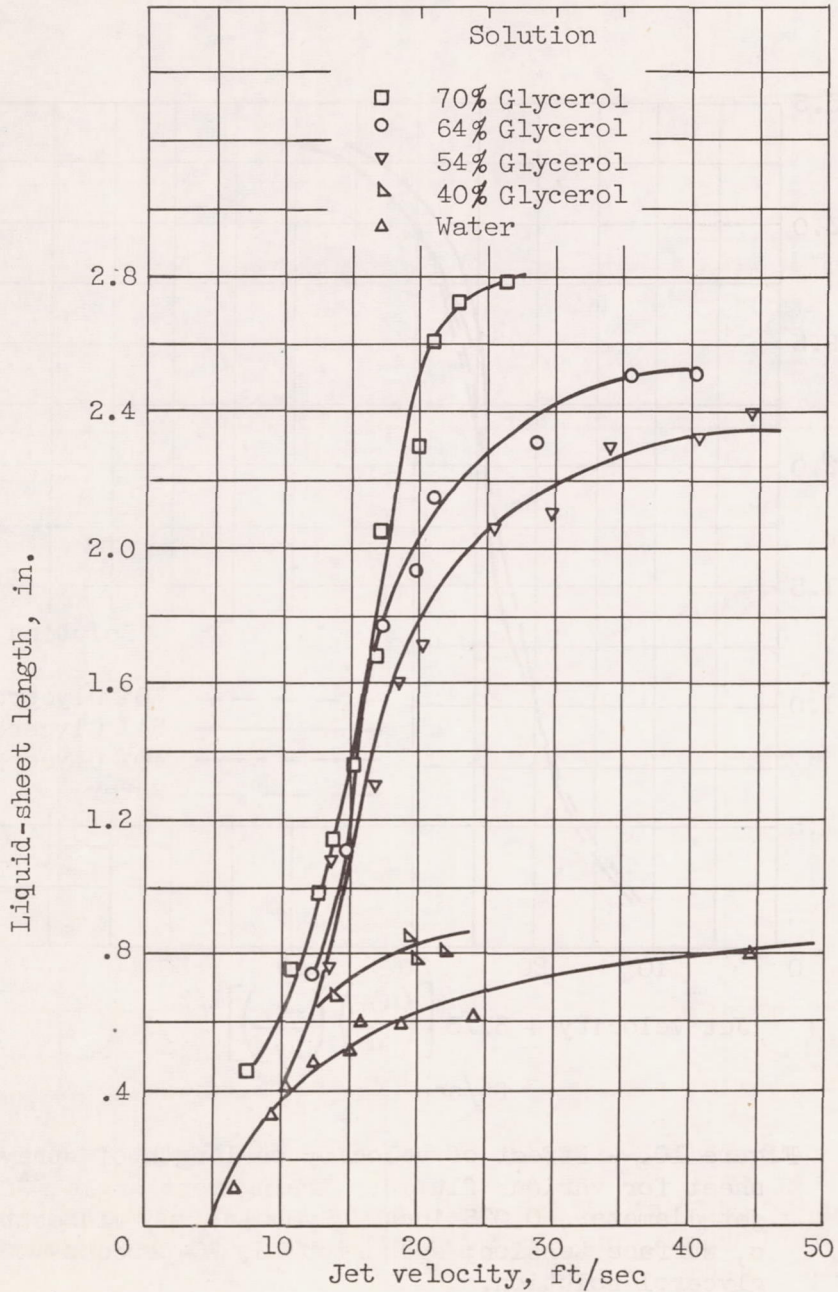

Figure 9. - Effect of jet velocity on length of spray sheet for various fluids. Impingement angle, 90°; jet diameter, 0.025 inch.

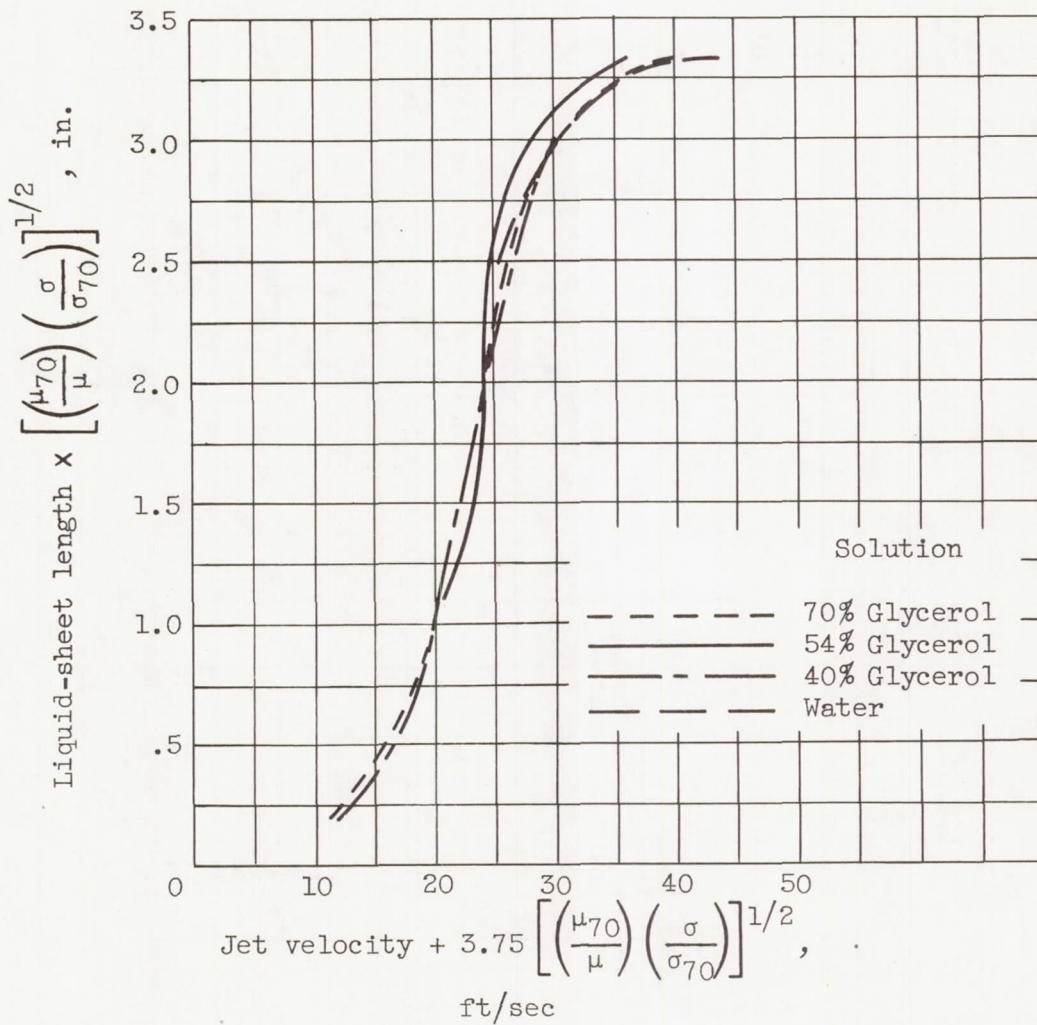

Figure 10. - Effect of velocity on length of spray sheet for various fluids. Impingement angle,  $90^\circ$ ; jet diameter, 0.025 inch. Symbols:  $\mu$ , viscosity;  $\sigma$ , surface tension; subscript 70, 70-percent-glycerol solution.

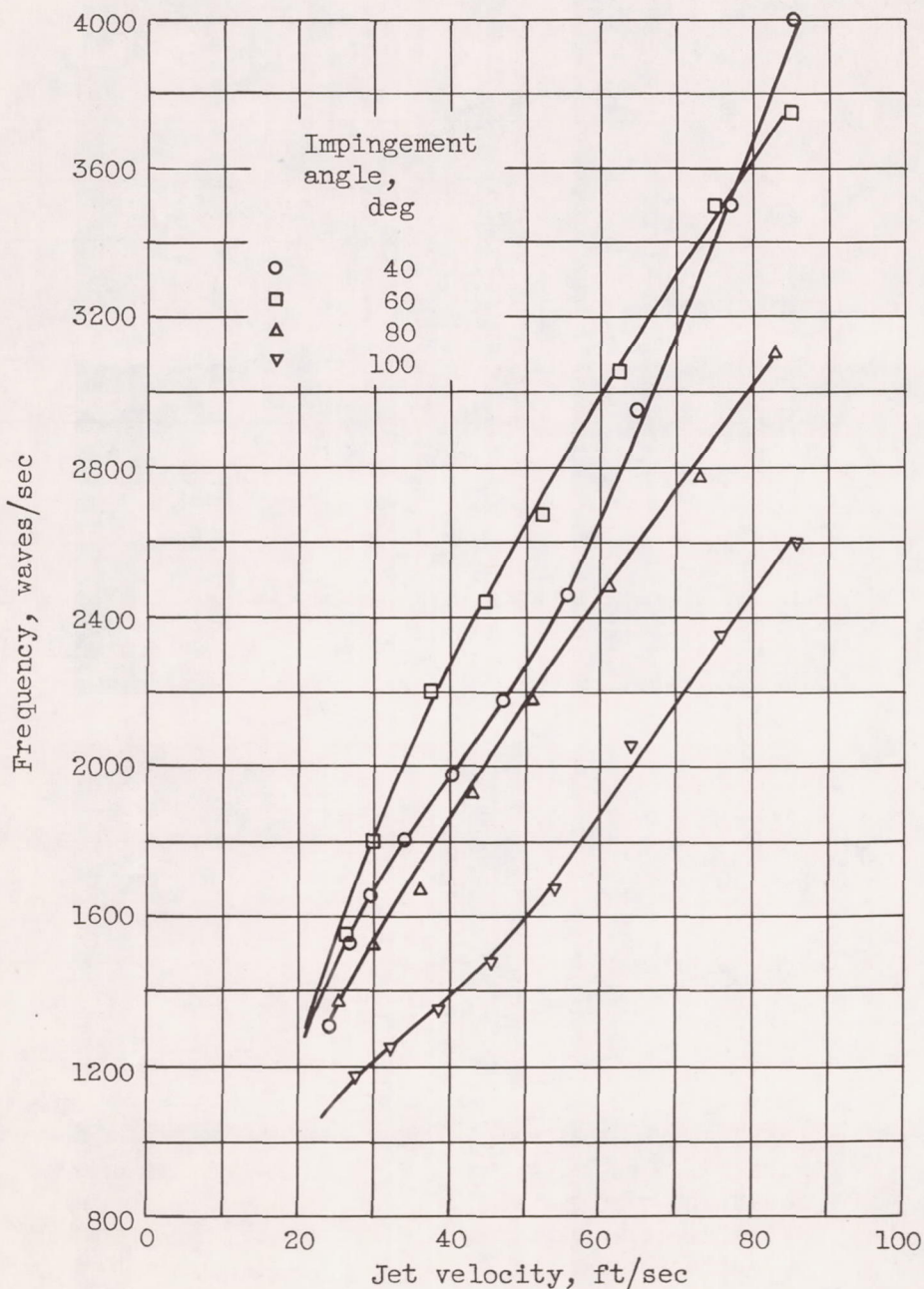

Figure 11. - Effect of jet velocity on wave frequency of fully developed spray of water for several impingement angles. Jet diameter, 0.025 inch.

4140

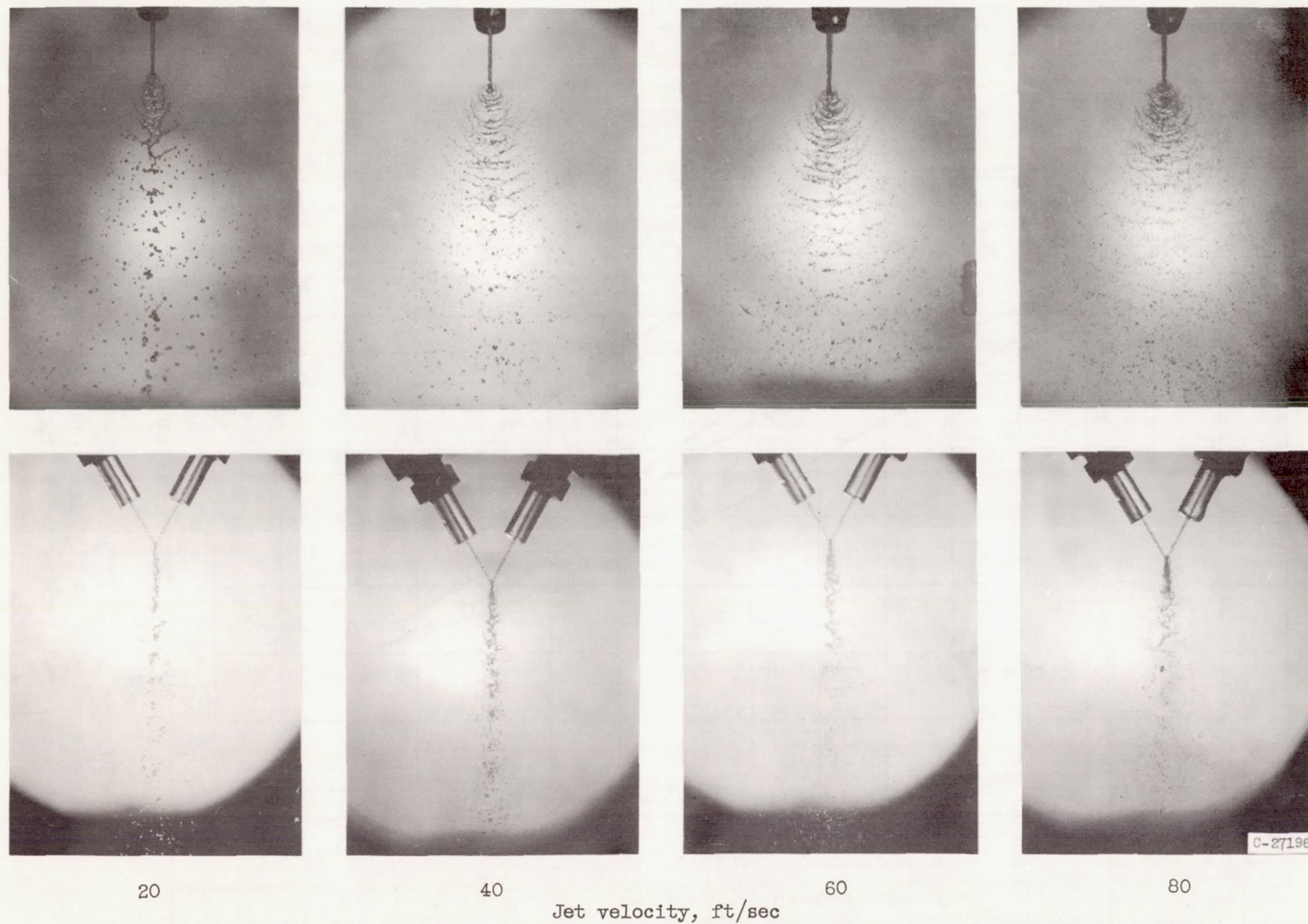

Figure 12. - Effect of jet velocity on fully developed spray pattern. Jet diameter, 0.025 inch; impingement angle,  $60^\circ$ ; fluid, water.



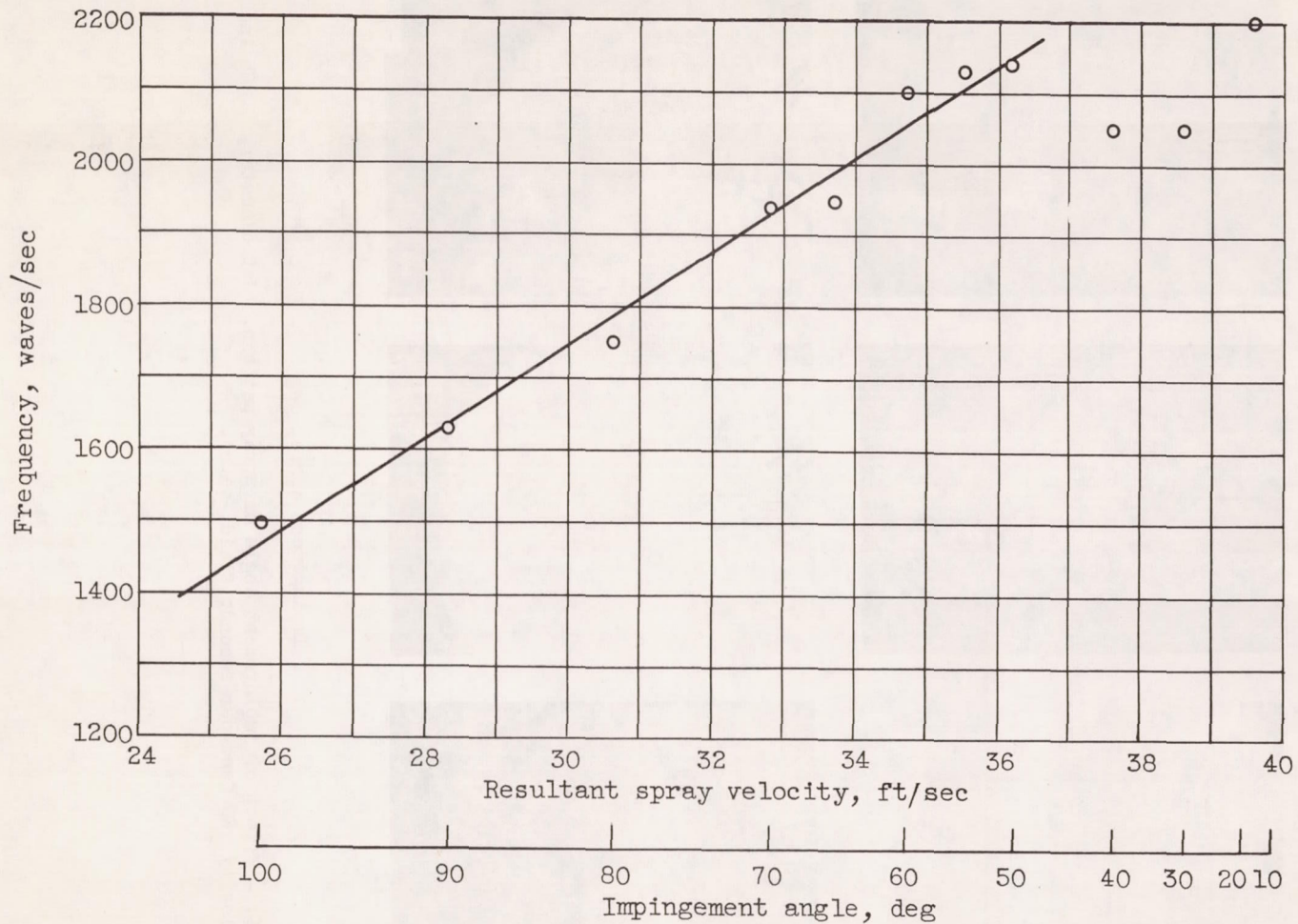

Figure 13. - Effect of impingement angle on wave frequency of fully developed spray of water. Jet diameter, 0.040 inch; jet velocity, 40 feet per second.

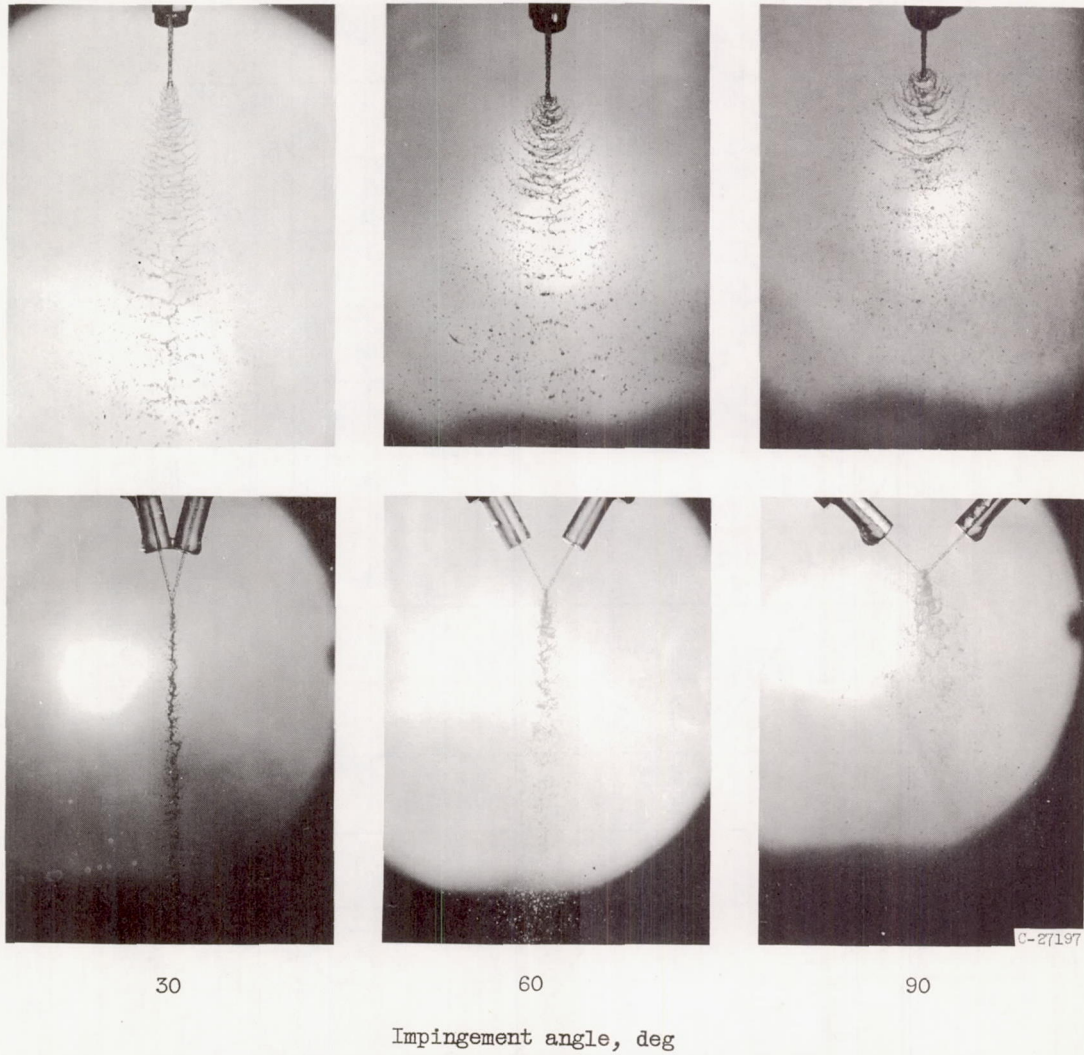

Figure 14. - Effect of impingement angle on spray pattern. Jet diameter, 0.025 inch; jet velocity, 60 feet per second; fluid, water.

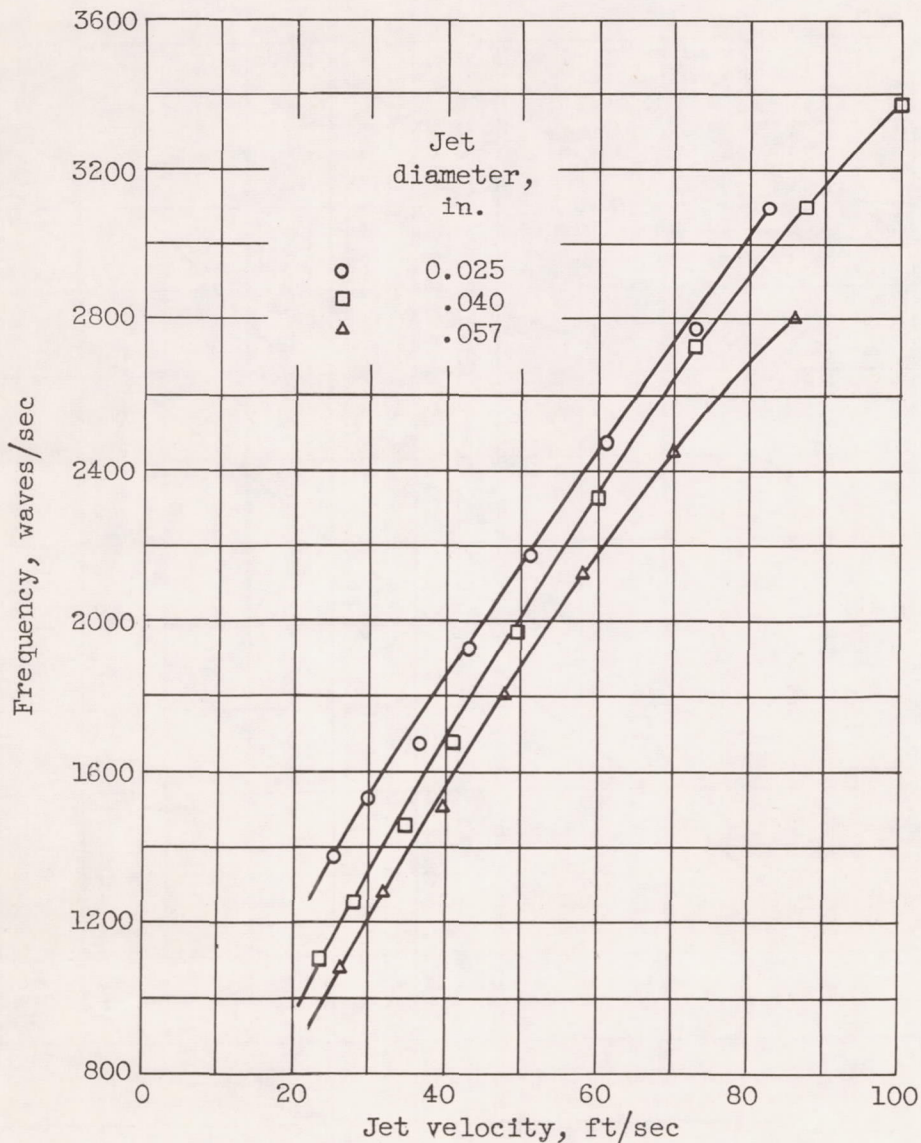

Figure 15. - Effect of jet diameter on relation between frequency and jet velocity. Impingement angle, 80°.

4140

CQ-4

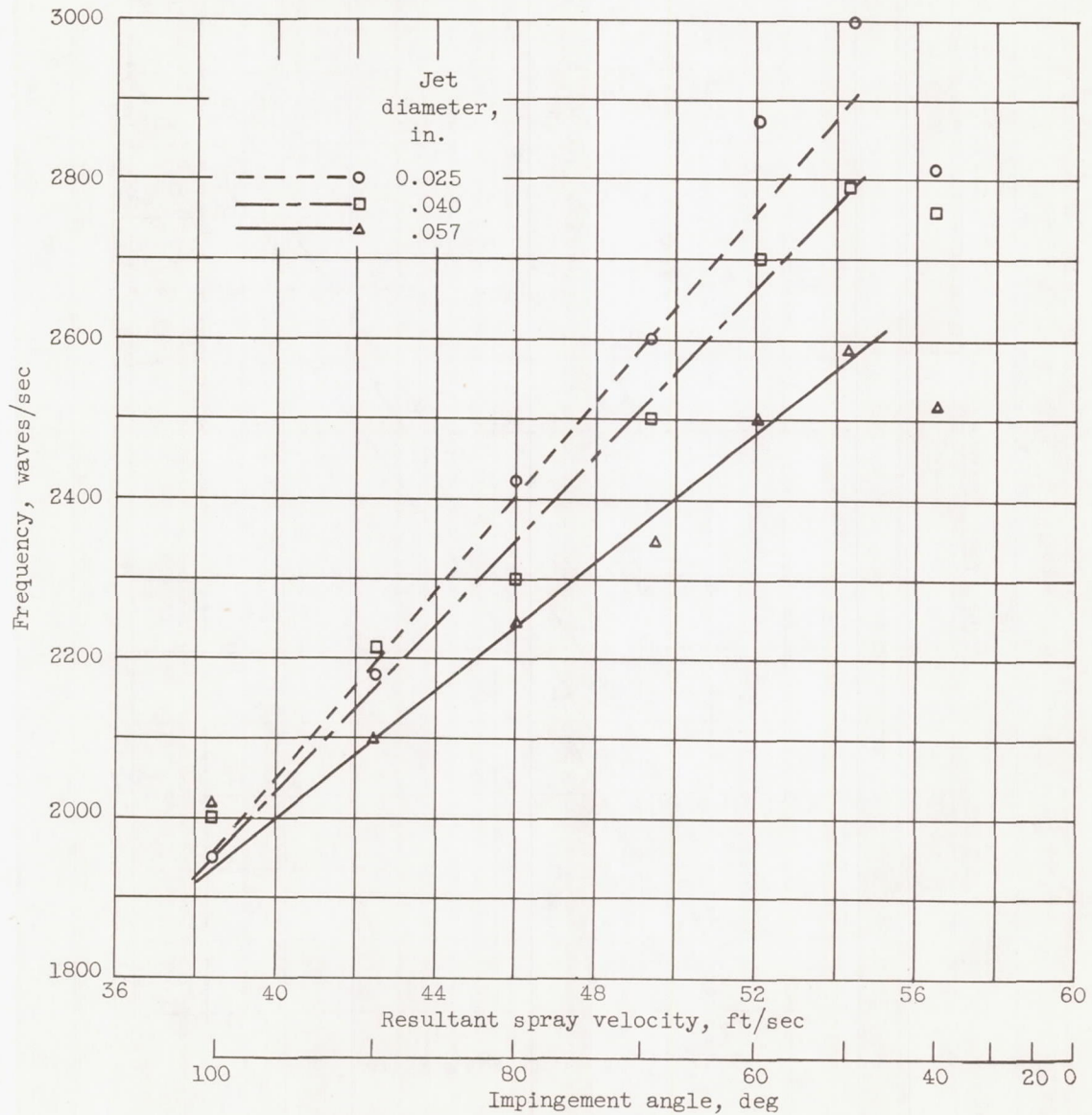
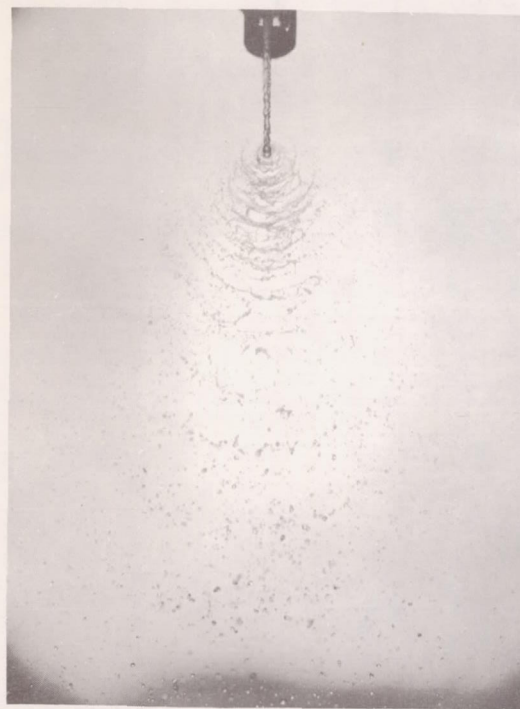

Figure 16. - Effect of jet diameter on relation between frequency and impingement angle. Jet velocity, 60 feet per second; fluid, water.



0.025



0.040



0.057

Jet diameter, in.

Figure 17. - Effect of jet diameter on spray pattern. Jet velocity, 50 feet per second; impingement angle,  $70^\circ$ ; fluid, water.

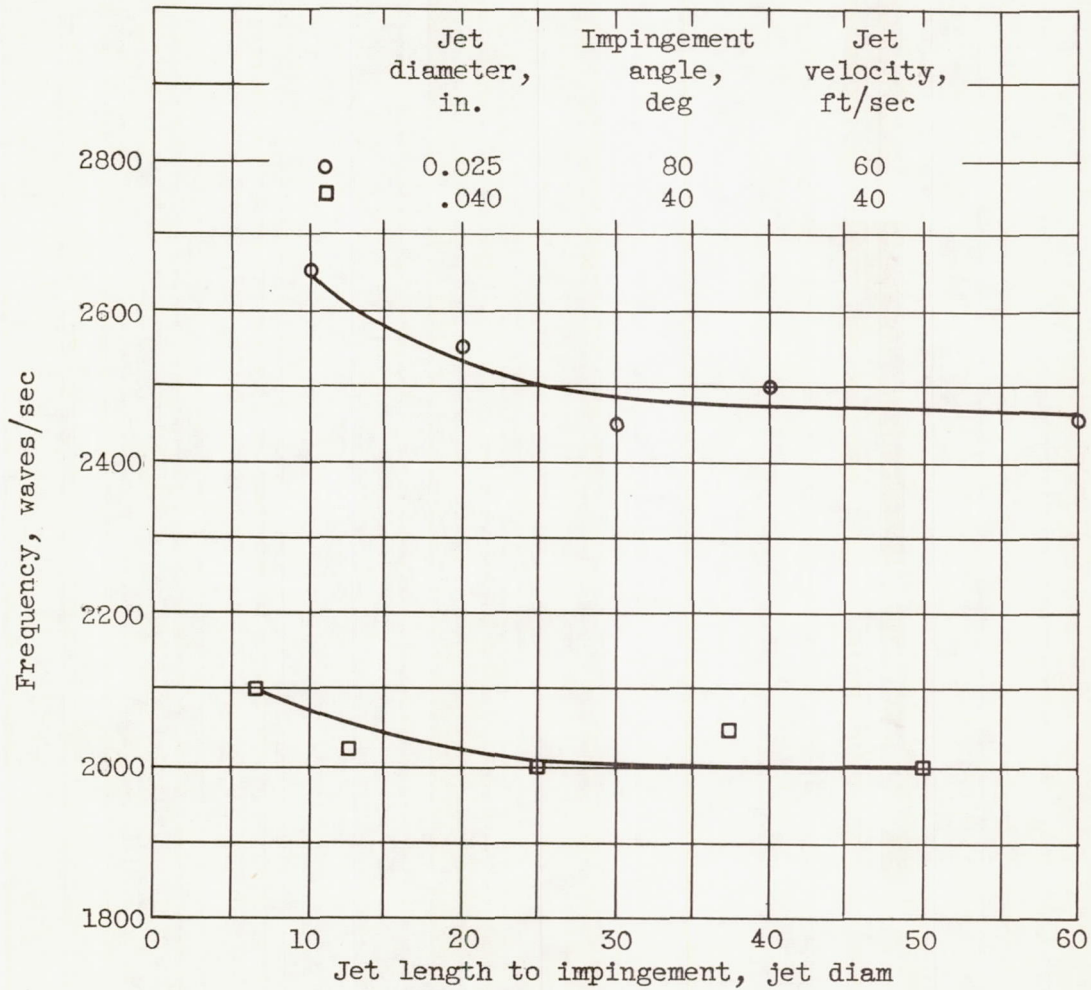
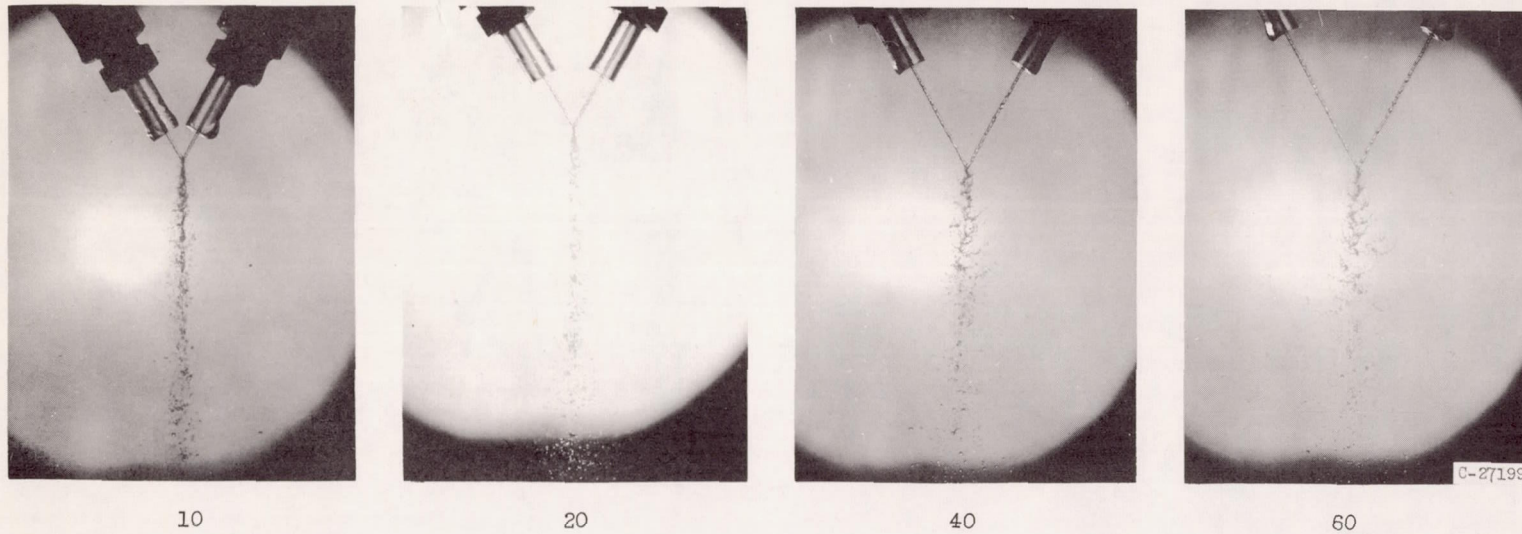
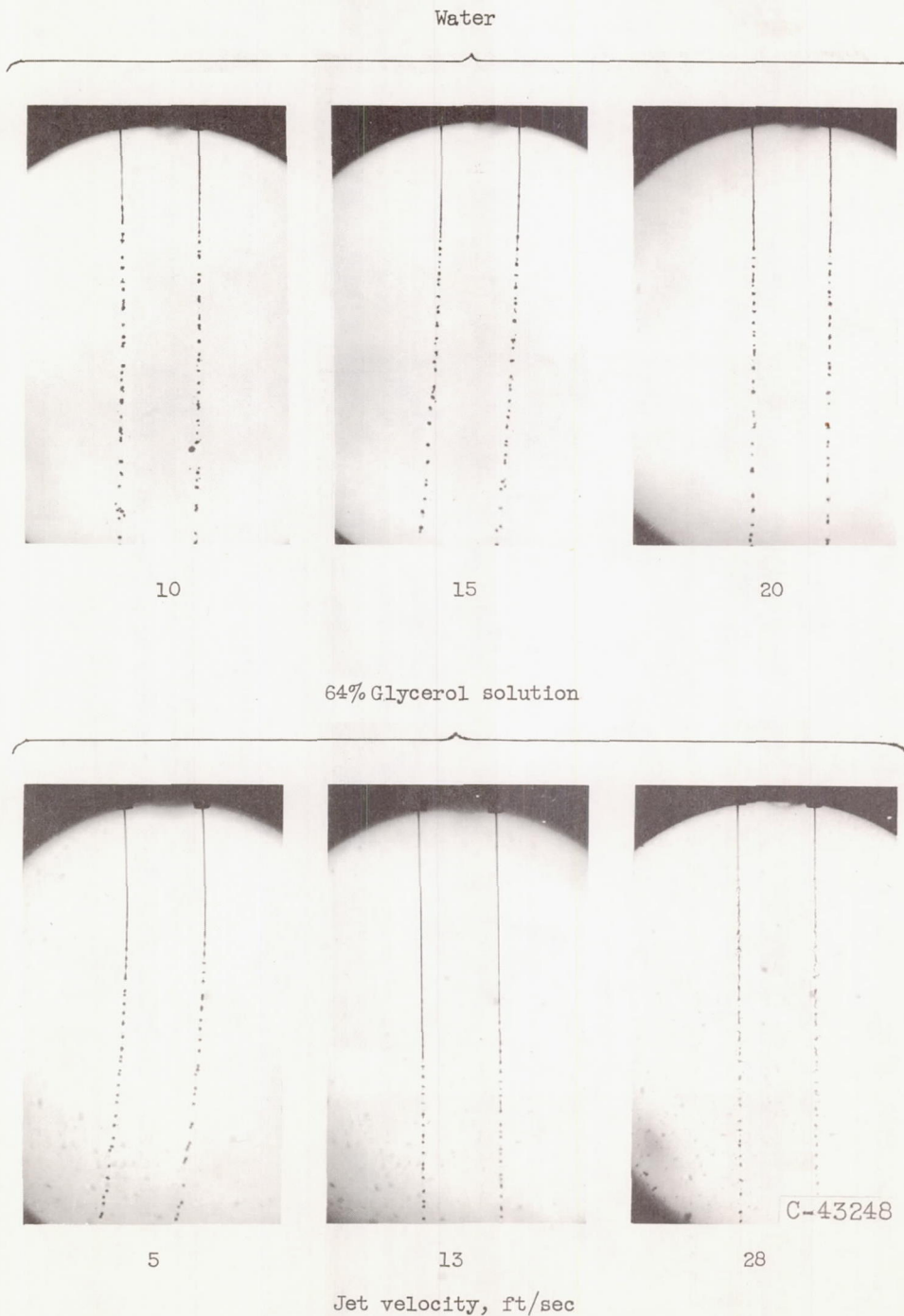

Figure 18. - Effect of jet length before impingement on spray frequency. Fluid, water.



$\frac{\text{Jet length}}{\text{Jet diameter}}$

Figure 19. - Effect of ratio of jet length to jet diameter on spray pattern. Jet diameter, 0.025 inch; jet velocity, 40 feet per second; impingement angle, 60°; fluid, water.



(a) Water and 64-percent-glycerol solution at low velocities.

Figure 20. - Effect of jet velocity on pattern of 0.025-inch-diameter single jets.



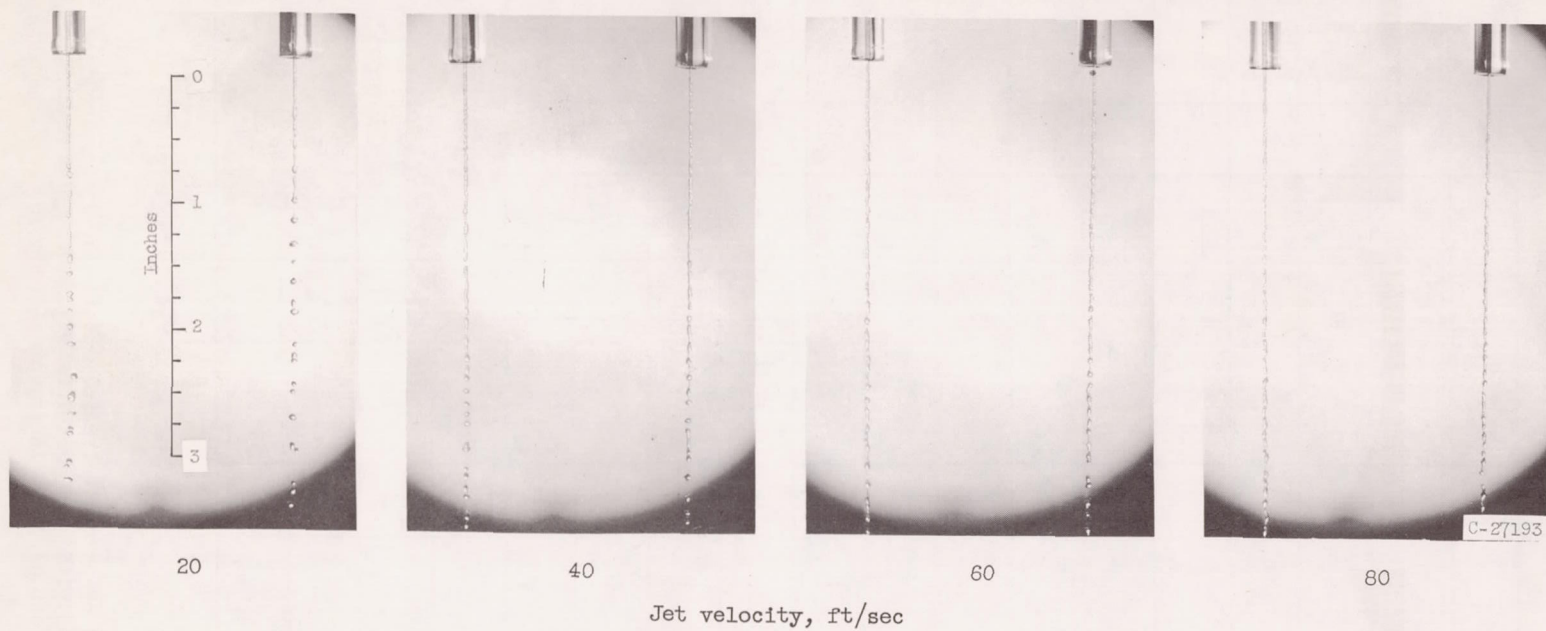

(b) Water at high velocities.

Figure 20. - Concluded. Effect of jet velocity on pattern of 0.025-inch-diameter single jets.

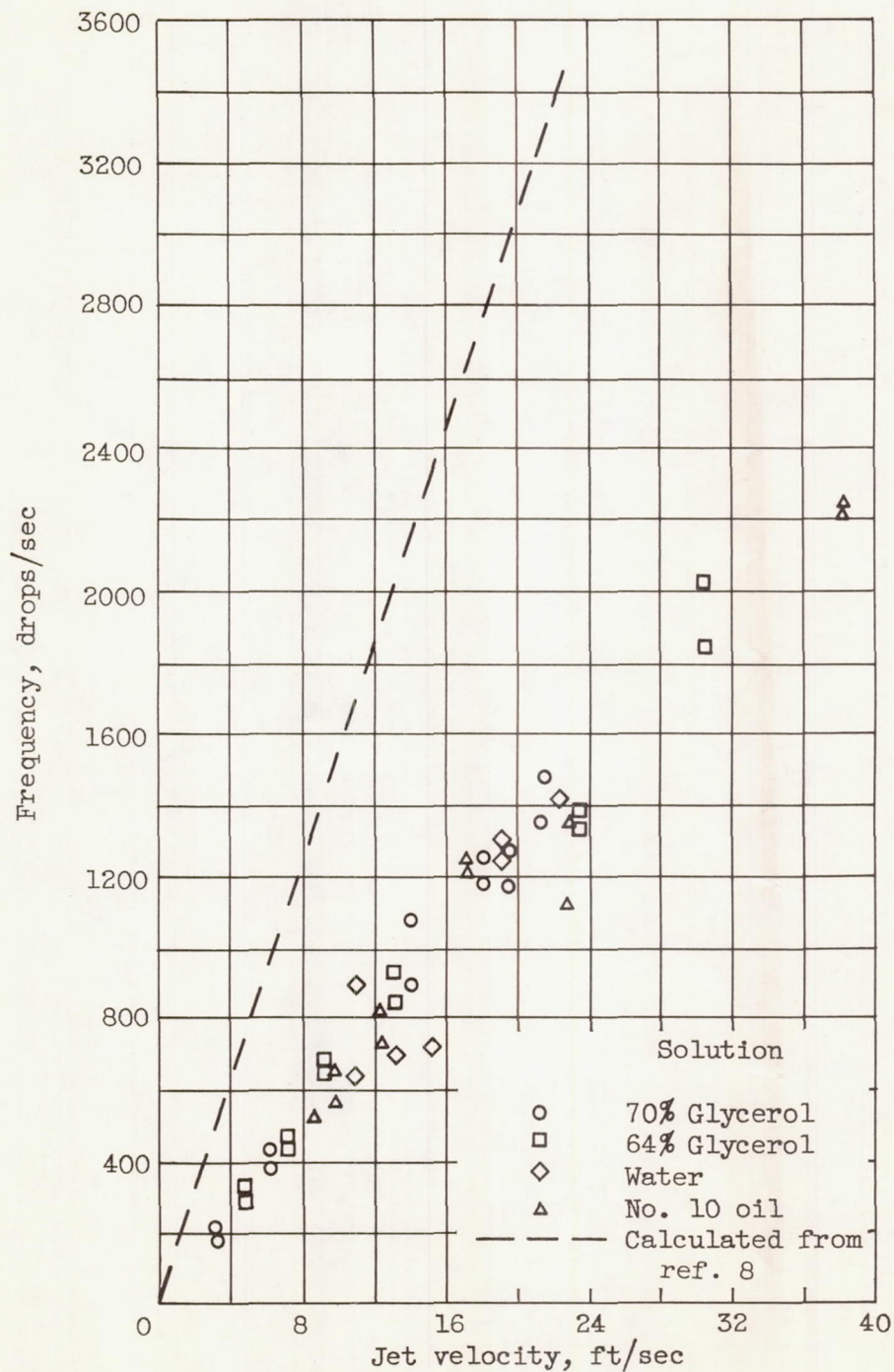

Figure 21. - Frequency of drops formed from single jet plotted against jet velocity.