

NACA
TN
3946

c. 1

NACA TN 3946

NATIONAL ADVISORY COMMITTEE FOR AERONAUTICS

LOAN COPY: R
AFWL (W
KIRTLAND AFI

0057111



TECH LIBRARY KAFB, NM

TECHNICAL NOTE 3946

DITCHING INVESTIGATIONS OF DYNAMIC MODELS AND EFFECTS
OF DESIGN PARAMETERS ON DITCHING CHARACTERISTICS

By Lloyd J. Fisher and Edward L. Hoffman

Langley Aeronautical Laboratory
Langley Field, Va.



Washington

February 1957

W
NATIONAL ADVISORY COMMITTEE FOR AERONAUTICS

TECHNICAL NOTE 3946

DITCHING INVESTIGATIONS OF DYNAMIC MODELS AND EFFECTS
OF DESIGN PARAMETERS ON DITCHING CHARACTERISTICS¹

By Lloyd J. Fisher and Edward L. Hoffman

SUMMARY

Data from ditching investigations conducted at the Langley Aeronautical Laboratory with dynamic scale models of various airplanes are presented in the form of tables. The effects of design parameters on the ditching characteristics of airplanes, based on scale-model investigations and on reports of full-scale ditchings, are discussed. Various ditching aids are also discussed as a means of improving ditching behavior.

INTRODUCTION

The designers of an airplane have control over many factors that will affect the chances of survival of the occupants of the airplane in a ditching. Since a considerable variation in ditching behavior is found in airplane designs that have similar performance in the air, it is evidently possible to choose values of design parameters that will give some measure of ditching safety without appreciable sacrifice of aerodynamic properties. Therefore, available ditching data are presented and evaluated herein in order to assist the designer and the operator in making preliminary ditching evaluations of airplanes by comparison with similar configurations or by the study of various design parameters. This information is based on data from scale-model investigations conducted at the Langley Aeronautical Laboratory and from actual full-scale ditchings. The data from ditching investigations with scale models are presented in the form of tables.

Scale-model investigations can give information regarding the motions of an airplane when ditched but data regarding the ability of personnel to withstand the motions, and subsequently to escape from the sinking airplane, must be obtained from other sources.

¹Most of the information presented herein was previously made available to the U. S. Military Air Services and the Civil Aeronautics Administration.

APPARATUS AND PROCEDURE

The investigations of the ditching characteristics of airplanes were conducted in Langley tank no. 2 with dynamic scale models. Damage which was likely to occur in a full-scale ditching was simulated in the models either by the removal of parts, by the installation of simulated crumpled sections, by the installation of scale-strength sections or aluminum-foil coverings which failed during the test, or by a combination of these methods. The models were launched either from the towing carriage or from the monorail so that they were free to glide onto the water at the desired landing attitude and speed. The control surfaces were set in such a manner that the model did not yaw or change attitude appreciably in flight. Landing attitude was measured between the longitudinal axis of the airplane and the smooth-water surface.

The behavior of the models was recorded from visual observations and from motion pictures of the tests. Average decelerations were derived from the landing speeds and lengths of run. Maximum longitudinal decelerations were measured with an accelerometer installed near the cockpit. Various accelerometers were used that had natural frequencies of about 20 to 70 cycles per second and all were damped to about 65 percent of the critical damping value. The reading accuracy of the least accurate instrument was about $\pm \frac{1}{2}g$.

RESULTS AND DISCUSSION

The results of the model-ditching investigations are shown in tables 1 to 37. The information in these tables is based on calm-water landing tests. In rough-water landings made parallel to waves or swells, the same general type of performance should be obtained. In landings made perpendicular to waves, however, more damage and more violent motions may occur, depending on the choice of ditching site and the size and portion of the wave contacted.

Effects of Design Parameters

Wing.- From a ditching standpoint, the vertical location of the wing with respect to the fuselage is a compromise between having the wing low enough to provide buoyancy to help keep the airplane afloat after ditching and having the wing high enough so that the landing flaps and engine installations (discussed further under "Flaps" and under "Engine installation") do not seriously impair ditching behavior. It is generally considered that the most favorable position of the wing is slightly above the bottom of the fuselage or in a low midwing position.

The thickness and size of the wings had little effect on ditching behavior other than the obvious effect on buoyancy. Sweptback and delta wings had little hydrodynamic influence on ditching but they did have aerodynamic influence on handling and landing characteristics. The flying wing appeared to have reasonably good ditching characteristics but it was very susceptible to damage although no violent motions occurred.

Flaps.- The landing flaps had a noticeable hydrodynamic effect on about 25 percent of the models investigated. For most of the models there was only a slight nose-down moment observed, and in no test was a flaps-up condition preferable. For certain models (as example, table 16), a flaps-down condition caused diving, but with the flaps retracted and with the corresponding increase in speed the damage and deceleration were even more severe than in the dives. It is therefore preferable to have flaps down in a ditching in order to obtain a low forward speed and thus to decrease fuselage damage; however, the flaps should be weak enough to fail before producing an undesirable diving moment. For airplanes having very low wings, the manner in which the flaps failed, that is, whether they were completely torn from the wing or whether the linkage failed and left the flaps free to rotate toward a neutral position, had an effect on the results. In table 28 it is noted that a flap which merely rotated toward a neutral position was occasionally detrimental.

Engine installation.- Reciprocating engines have caused differences in airplane ditching behavior because of the location of the nacelle. When placed low on an airplane, the engine nacelle acts as a "water brake" and increases decelerations; therefore, it is generally desirable to place the engine well above the level of the bottom of the fuselage.

Jet engines mounted on the wing (table 11) or turbopropeller engines mounted similarly will have about the same effect as a reciprocating-engine nacelle except that they may be smaller and have less water resistance. Pusher-propeller engines installed on the wing (table 10) also may have low water resistance.

Jet engines have brought about a design freedom in engine location because propeller clearance is no longer a factor. Jet engines installed at the wing root, on struts, under the fuselage, and on the side of the fuselage have been investigated in model-ditching tests. In general, the wing-root nacelles have very little effect on dynamic behavior and will have little influence on structural damage. The strut-mounted nacelles (tables 12 and 26) will probably be torn off in a ditching but will have little effect on dynamic behavior. With engine nacelles mounted under the fuselage, various effects can be expected, depending on the rigidity and the fore and aft location of the installation. If the engines are too far aft, a dive may be produced. A forward location may cause porpoising, but generally an intermediate position can be found that will produce a smooth run. Side-mounted engine nacelles will

probably require the horizontal tail to be mounted high on the vertical tail. Generally, with a high tail the rear part of the fuselage runs deeply in the water and the nacelles cause considerable spray and drag as they enter the water. If the nacelles tear away during a ditching, extensive structural damage may result and possibly the aft portion of the fuselage will be torn away. Fighter airplanes usually have jet engines located within the fuselage; therefore, the location of the air intake is the most important feature of such installations. The inlets may cause detrimental behavior when a ditching is made at a low enough attitude to get them into the water at high speeds (see table 23). Usually, however, an airplane can be landed so that the inlets are held clear of the water until a fairly slow speed is reached. Tests were made of one fighter airplane model that had jet engines mounted on the underside of the fuselage (table 20); diving did not occur with this particular installation, but some very high decelerations resulted.

Tail surfaces.- The location of the tail surfaces has not previously been considered to have hydrodynamic influence on ditching behavior. However, data obtained in scale-model investigations indicate that the horizontal-tail location can affect the attitude at which the airplane will run on the water. When the horizontal tail is located very high on the vertical tail the model will, when there is a tendency to trim up, trim higher than when the horizontal tail is in a low position. Occasionally a horizontal tail was partially torn away in the scale-model tests but no appreciable change in behavior due to this damage was noted.

Landing gear.- It is considered advisable that ditchings be made with the landing gear retracted because an extended gear usually causes diving. (For example, see table 32.) There have been some full-scale ditchings with wheels down in which diving did not occur, but apparently these were exceptional.

The arrangement of the landing gear when retracted has not shown an appreciable effect on ditching behavior, but it can affect the amount of damage and the safety of personnel during a ditching. Tricycle-gear arrangements have nose-wheel doors that are likely to fail in a ditching. In no case have scale-model investigations shown that such a failure will cause diving, but secondary failures that ensue as a result of the water pouring into this opening may be extensive enough to endanger nearby personnel. In general, the landing-gear installation that has a tail wheel tends to give a better arrangement for ditching than the tricycle gear, provided that all wheels are retracted. However, if a ditching aid attached under the nose of the airplane were considered, the tricycle landing gear would provide structural members advantageously located to carry the concentrated load of the ditching aid. The bicycle-landing-gear installation requires doors in the fuselage bottom which are undesirable in ditching unless they are much stronger than doors generally are. In investigations of one airplane model employing the bicycle landing

gear, the simulated main-wheel doors failed (table 12). In this test no detrimental behavior occurred but the fuselage was flooded. The outrigger wheels required with a bicycle main gear offer no difficulties in ditching. A contribution of the bicycle-landing-gear design favorable to ditching is a very strong fuselage structure. The fuselage of some airplanes has broken apart near the wing in ditching but it is unlikely that a fuselage strong enough to support a bicycle landing gear would separate in this manner. In an investigation of a model with the main landing gear located in nacelles on the sides of the fuselage (table 33), the nacelles crumpled considerably but the damage did not affect the ditching behavior. Damage is likely to occur when the nacelle type of wheel fairing is used, and the damage could have undesirable effects on flotation unless precautions are taken to prevent entry of water into the main part of the fuselage.

Fuselage strength.- Most airplanes could be ditched with relative safety if extensive damage to the fuselage could be avoided; therefore, the strength of the fuselage bottom is probably the most important parameter influencing ditching behavior. It is impractical to consider designing fuselages which will not fail in ditching, but damage may be reduced by using ditching aids (discussed further under "Ditching Aids"), and the danger to personnel may be minimized by providing safe ditching stations (discussed under "Safe Location of Personnel"). The middle third of the fuselage bottom is considered the critical region because of its susceptibility to damage and the consequent effects on ditching behavior. The investigations with models by the use of scale-strength bottoms to determine the location and amount of probable damage have substantiated this conclusion.

Bombers are particularly susceptible to damage and undesirable ditching behavior because the bomb-bay doors are usually located in the critical region. Manufacturers estimate that the bomb-bay doors have an ultimate strength in resistance to water loads of approximately 1/2 to 2 pounds per square inch and that the remainder of the lower fuselage is also comparatively weak. Bomb-bay-door failure generally occurs and sometimes causes violent behavior; however, whether or not violent behavior occurred, safe ditching stations in the rear part of the fuselage are generally unobtainable because of the rush of water through the airplane when damage occurs.

There is a wide variation in the bottom strength of fighter airplanes; some have strength as low as 2 pounds per square inch, but others can withstand a pressure of 40 pounds per square inch on some parts of the fuselage bottom. Fighters frequently sustain extensive damage to the bottom skin, but the structure usually remains more or less intact. If damage does not occur, fighters will make smooth runs or at worst they might skip. If damage occurs, almost any behavior from a smooth run to a violent dive or flipover might result according to the amount of damage and the particular airplane configuration.

Transport airplanes have marginal-strength fuselages - the lower part of the fuselages sustains some damage when ditching but usually is not demolished. The average resistance to water loads is estimated by manufacturers to be from 8 to 12 pounds per square inch. The fuselage strength of a transport is greater than that of a bomber because the requirements for cargo floors and pressurized cabins in the transport contribute to a stronger fuselage and because the bomber fuselage is considerably weakened by the presence of the bomb-bay doors. Damage usually does not cause the behavior in transports to be violent, but water flooding into the fuselage through damaged sections is a hazard.

Fuselage shape.- Some current airplanes have large amounts of curvature at the rear of the fuselage. A high degree of longitudinal curvature results in a suction which causes the models to trim up in the water (tables 30, 31, and 37). A high degree of lateral curvature at the rear of the fuselage results in suction and motions similar to those produced by high longitudinal curvature (ref. 1). Trimming up is not necessarily detrimental but could contribute to undesirable results such as skipping and subsequent diving. A fuselage bottom with little longitudinal and lateral curvature tends to decrease trimming up but is undesirable because of the accompanying high water loads. There are indications that flattened cross sections in combination with high longitudinal curvature tend to cause skipping (tables 19 and 30). Moderately curved sections rearward of the center of gravity are desirable with respect to stability and water loads.

From early scale-model tests, it was concluded that the small differences in the ratio of fuselage length forward of the center of gravity to the total fuselage length indicated no consistent differences in the hydrodynamic performance. Recent trends in fighter design have led to increases in this ratio from approximately $1/4$ to $1/2$. There is evidence that the increase in nose length has been advantageous to fighter airplanes because it has resulted in a decrease in diving or nosing-in tendency. For bombers, the increase in this ratio has been small and there has been little noticeable effect on ditching behavior.

Curvature at the nose also has an influence on ditching behavior. A fuselage that is more or less straight on the bottom but curves up abruptly at the nose offers less nose-up moment and thus is more likely to dive than one that curves up gradually. The desirability of gradual curvature of the forward part of the fuselage has been substantiated by limited tests.

The effect of cross-sectional curvature of the forward part of the fuselage has not been investigated but it appears that a moderately curved cross section would probably be most desirable.

Size.- The physical magnitude of airplanes appears to affect the degree of violence of ditching behavior. Small differences are not

noticeable but in the overall range from fighters to large bombers and transports the effect of size and pitching moment of inertia is apparent. As the size of airplanes increases, the ditching behavior becomes less violent.

Interior arrangement.- Probably the item of interior arrangement that has the greatest effect on ditching behavior is the bulkhead just aft of the bomb bay. Bomb-bay doors usually fail; therefore, this bulkhead is immediately subjected to water loads. For the configurations shown in tables 11 and 13, diving was prevented by removing the bulkhead and the part of the fuselage bottom that might be torn away if the bulkhead failed. In table 4, removing the bulkhead or part of the bulkhead reduced the severity of diving. There have been cases in which bomb-bay doors failed but diving was not produced; in such cases the bulkhead caused no detrimental behavior and offered some protection to the interior of the rearward part of the fuselage.

Protuberances.- Protuberances under the wing or the fuselage of an airplane may cause undesirable ditching behavior and high longitudinal decelerations. Protuberances located rearward of the center of gravity are the most undesirable and may cause diving. Radiators projecting below the fuselage rearward of the center of gravity have caused dives. Radiators under the nose have caused violent ditching behavior and high decelerations. Belly-gun turrets and radar housings placed forward of the center of gravity generally have caused no diving or other violent motions when tested on models (tables 8 and 14). However, such protuberances located rearward of the center of gravity have caused diving (table 3).

Scale-model investigations with cargo containers located under the fuselage (table 27(b)) indicated that no detrimental effect was due to the presence of the cargo container; in fact, it was beneficial because it afforded protection to the bottom of the airplane. The construction of the container was such that it caved in on contact with the water and thus acted as a shock absorber.

The need for greater fuel storage in jet-propelled airplanes has resulted in the use of external fuel tanks, usually located under the wing or at the wing tip. Streamlined auxiliary fuel tanks under the wing (table 23) should be jettisoned before ditching because they increase hydrodynamic resistance and because their shape is such that they produce a suction force detrimental to successful ditching. Tanks that were modified in shape by the addition of either chine strips or dead rise with chines (ref. 2) would improve the ditching behavior if they were strong enough to withstand the water loads. Wing-tip tanks probably will not be detrimental since they do not enter the water until a low speed is reached and, if empty, they offer additional buoyancy (tables 21 and 24).

Safe Location of Personnel

The availability of good ditching stations for personnel will in some measure compensate for unavoidable deficiencies in hydrodynamic characteristics. Scale-model investigations indicate that decelerations in severe ditchings may exceed $10g$, but apparently personnel can withstand such decelerations if they are braced against or strapped to a unit of the airplane that will not fail. The danger that parts of the airplane will be broken off and thrown against occupants cannot be completely eliminated, but adequate strength can be provided to prevent obvious hazards, such as overhead turrets, from being torn off.

Available records of ditchings indicate that the survival rate for fighter pilots is higher now than in the past. Although the behavior of current fighter airplanes is sometimes violent, a more important factor may be the increase in use of the safety harness. The fuselage of a fighter is strong and the pilot can usually be braced well enough to withstand the decelerations. The bottom skin of the fuselage may be damaged but there is little water flow through the pilot's compartment.

In bomber and transport airplanes, the pilot's compartment is usually high enough to avoid quick flooding except in a dive, damage is not severe, and escape hatches are available. The most dangerous ditching stations in a bomber airplane are rearward of the bomb bay because of the likelihood of an inrush of water through the low-strength bomb-bay doors and the probable failure of the bulkhead just rearward of the bomb bay. The survival rate for bombers as a whole is very low, and as a class the bomber is considered to have unacceptable ditching characteristics.

In a transport airplane, the fuselage generally has no predominantly weak part, such as bomb-bay doors, and the floor of the passenger compartment is more substantial than the floor of a bomber. Consequently, the rearward part of the fuselage is possibly less hazardous in a transport than in a bomber; however, because of the chance that the rear fuselage might sustain extensive damage, ditching stations should be as far forward as possible. In transports that have double decks (tables 36 and 37), the upper deck offers relatively safe ditching stations. The most hazardous type of transport, as far as ditching stations are concerned, is the "flying boxcar" (tables 29, 30, 32, and 33). This type of airplane has large doors and a wide flat bottom that are subject to high water pressures; therefore, some damage is very probable. The high wing of the flying boxcar affords no buoyancy until the airplane sinks deeply; consequently, the cargo or passenger compartment is likely to be flooded to a hazardous extent.

It would seem that the ditching requirements for transports should be more severe than for other types of airplanes because of the large number of passengers involved and the general lack of training in ditching procedures.

Ditching Aids

When the use of an airplane is such that a high degree of ditching safety is required, a ditching aid may be the best method of insuring such safety. If a ditching aid were included as an integral part of the airplane in the early stages of design, it possibly could be incorporated with little or no penalty in performance.

Hydroflap.- One method which can be used to prevent diving or "nosing in" during the high-speed part of a ditching run is to provide a device under the fuselage forward of the center of gravity that will have sufficient hydrodynamic lift to furnish the necessary positive pitching moment. Scale-model investigations have been made with planing surfaces, called hydroflaps, installed on models for this purpose. The hydroflaps, which usually have an incidence angle of about 30° , have been tested in various forms. In some investigations, existing rectangular doors in the fuselage were braced open to form hydroflaps (tables 2(b) and 15(b)). In other investigations where the hydroflap had a trapezoidal or triangular plan form (tables 4(b), 11(b), and 33(b)), smoother runs were obtained than with rectangular plan forms. In addition to eliminating the diving, hydroflaps reduced the amount of damage sustained by scale-strength sections.

Certain types of airplanes require speed brakes or dive brakes. These devices have various forms, one of which is an approximately flat plate hinged at its leading edge to the bottom of the fuselage and opening outward. A few airplanes have had this type of brake located forward of the center of gravity. Such a device possibly could be located so that it could serve as a hydroflap as well as a speed brake. Speed brakes have not yet been located far enough forward of the center of gravity to serve advantageously as hydroflaps and have not been made strong enough for such use. Scale-model investigations (table 24(b)) indicate that such a brake could be used as a ditching aid if these requirements were met.

Hydrofoil.- Two general methods for using hydrofoils to improve hydrodynamic ditching characteristics of airplanes have been investigated with scale models: in one method, the hydrofoil was placed below the nose of the model with a positive incidence, and in the other it was placed aft of the center of gravity with a negative incidence in order to hold the tail down. Both schemes were effective in improving the performance of the models, but the hydrofoil below the nose of the model was a more positive and practical installation. In addition to improving ditching behavior, the hydrofoil forward of the center of gravity offered the possibility of reducing fuselage damage.

Hydro-ski.- Another possible ditching aid is a planing surface that can be extended on struts so that in a landing the airplane rides on the planing surface and the main body of the airplane is not subjected to

large water loads at high water speeds. Such a device has been called a hydro-ski (tables 14(c), 27(c), and 34(b)). With a hydro-ski ditching aid, the hazardous motions and structural damage associated with ditching can be eliminated. For a bomber airplane, twin skis retracting into the side of the fuselage or into the wings could be used. For a transport airplane, either a single ski or twin skis retracting into the bottom of the fuselage would be practical.

CONCLUDING REMARKS

Performance requirements and the relatively low frequency of emergency landings even in wartime make it unlikely that airplanes will ever be designed specifically for "safe" ditchings. It appears possible, however, to reduce the hazards by some attention to the effects of the design parameters. It may also in certain cases be possible to incorporate ditching aids to protect the structure from peak water loads without significant performance penalties. These possibilities together with the establishment of proper approach procedures, provision of adequate means of escape, and early rescue remain the most effective means of increasing survival rates in future ditchings.

Langley Aeronautical Laboratory,
National Advisory Committee for Aeronautics,
Langley Field, Va., November 16, 1956.

REFERENCES

1. McBride, Ellis E., and Fisher, Lloyd J.: Experimental Investigation of the Effect of Rear-Fuselage Shape on Ditching Behavior. NACA TN 2929, 1953.
2. McBride, Ellis E.: Preliminary Investigation of the Effects of External Wing Fuel Tanks on Ditching Behavior of a Sweptback-Wing Airplane. NACA TN 3710, 1956.

TABLE 1

SUMMARY OF MODEL-DITCHING INVESTIGATION OF BOMBER A

[Model scale, $\frac{1}{10}$; gross weight, 21,500 lb; center-of-gravity location, 28 percent M.A.C.; all values full scale]

Damage simulated by removal of parts (crosshatched areas).

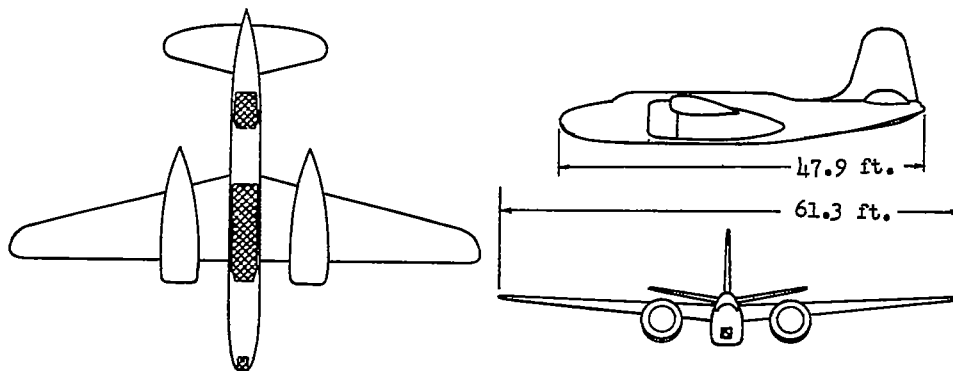

Landing attitude, deg	Flap setting, deg	Landing speed, knots	Length of run, ft	Maximum longitudinal deceleration, g units	Average longitudinal deceleration, g units	Motions of model (*)
Undamaged model						
2	0	104	200	--	$2\frac{1}{2}$	u h
2	40	104	200	--	$2\frac{1}{2}$	u h
6	0	104	400	--	1	u h
6	40	87	200	--	$1\frac{1}{2}$	u h
10	0	87	350	--	1	u h
10	40	69	200	$1\frac{1}{2}$	1	u h
Damaged model						
2	40	104	150	$5\frac{1}{2}$	3	b
†10	40	69	100	3	2	b

*In this column, the letters indicate the following motions:
 b ran deeply - the model settled deeply in the water with little change in attitude
 h ran smoothly - the model made a very stable run
 u trimmed up - the attitude of the model increased while running in the water

†Recommended ditching attitude and flap setting.

Remarks: Simulation of damage on this model stopped the trimming-up tendency and caused the model to run deeper in the water. The large nacelles caused violent turns when the model was ditched with one wing low.

TABLE 2

SUMMARY OF MODEL-DITCHING INVESTIGATION OF BOMBER B

[Model scale, $\frac{1}{12}$; gross weight, 25,730 lb; center-of-gravity location, 28 percent M.A.C.; all values full scale]

(a) Without hydroflap.

Damage simulated by removal of parts (crosshatched areas).

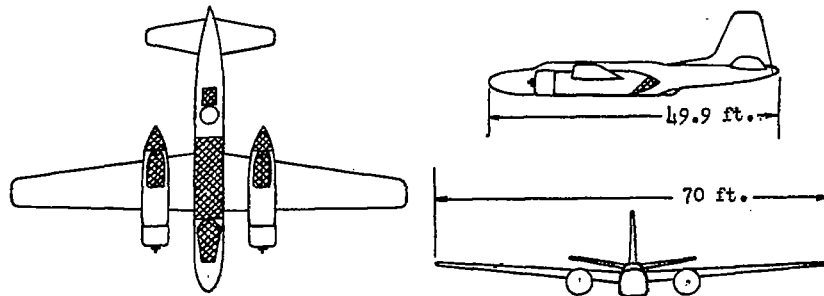

Landing attitude, deg	Flap setting, deg	Landing speed, knots	Length of run, ft	Maximum longitudinal deceleration, g units	Average longitudinal deceleration, g units	Motions of model (*)
Undamaged model						
3	55	102	400	2	1	s d ₁
3	55	102	400	3	1	s t
8	0	115	600	4 $\frac{1}{2}$	1	s t
8	55	96	500	--	1	h
13	0	102	250	8	2	d ₁
13	55	90	150	5	2 $\frac{1}{2}$	d ₁
Damaged model						
3	55	101	100	--	4 $\frac{1}{2}$	d ₁
8	0	115	250	6 $\frac{1}{2}$	2 $\frac{1}{2}$	d ₁
[†] 8	55	86	100	--	3 $\frac{1}{2}$	d ₁
13	0	102	250	--	2	d ₁
13	55	86	150	--	2	d ₁

*In this column, the letters indicate the following motions:

- d₁ dived violently - the model stopped abruptly in a nose-down attitude with most of the model submerged
 h ran smoothly - the model made a very stable run
 s skipped - the model rebounded from the water
 t turned sharply - the model pivoted quickly about a vertical axis

[†]Recommended ditching attitude and flap setting.

Remarks: The behavior of the model was exceptionally violent. Violent dives occurred with the undamaged model. In general, the dives at the attitude of 8° were less violent than those at the attitude of 13°. When the model was ditched with one wing slightly low, the large nacelles dug into the water and caused sharp turns.

TABLE 2 - Concluded

SUMMARY OF MODEL-DITCHING INVESTIGATION OF BOMBER B

(b) With hydroflap.

Damage as shown in three-view sketch. All-purpose nose door (open at an angle of 30° to thrust line) used as hydroflap.

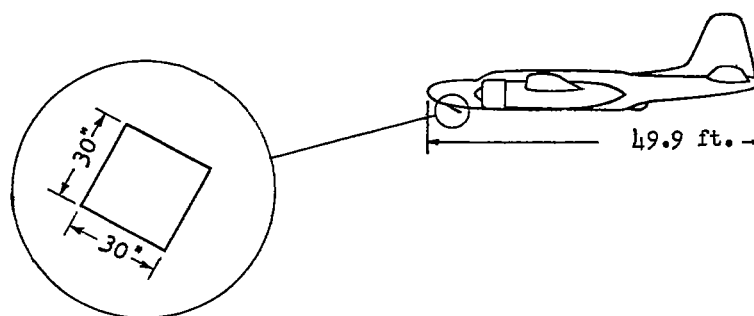

Landing attitude, deg	Flap setting, deg	Landing speed, knots	Length of run, ft	Maximum longitudinal deceleration, g units	Average longitudinal deceleration, g units	Motions of model (*)
3	55	101	300	--	2	p
†8	55	86	250	$3\frac{1}{2}$	$1\frac{1}{2}$	p
13	55	86	200	--	$1\frac{1}{2}$	p

*In this column, the letters indicate the following motions:

p porpoised - the model undulated about the transverse axis with some part of the model always in contact with the water

†Recommended ditching attitude and flap setting.

Remarks: Rather violent porpoising runs occurred with the hydroflap, but these runs were considerably better than the violent dives that occurred without the hydroflap.

TABLE 3

SUMMARY OF MODEL-DITCHING INVESTIGATION OF BOMBER C

[Model scale, $\frac{1}{16}$; gross weight, 57,000 lb; center-of-gravity location, 30 percent M.A.C.; all values full scale]

Damage simulated by removal of parts (crosshatched areas).

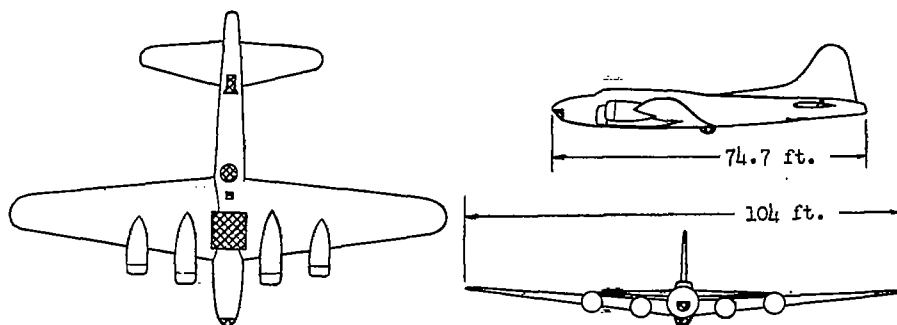

Landing attitude, deg	Flap setting, deg	Landing speed, knots	Length of run, ft	Maximum longitudinal deceleration, g units	Average longitudinal deceleration, g units	Motions of model (*)
Undamaged model						
0	45	122	---	7	---	d_1
$3\frac{1}{2}$	45	104	---	--	---	d_1
7	0	104	---	8	---	d_1
7	45	87	---	$6\frac{1}{2}$	---	$t d_1$
10	0	87	---	--	---	d_1
10	45	87	---	--	---	d_1
Damaged model						
0	45	122	---	$7\frac{1}{2}$	---	t
$3\frac{1}{2}$	45	104	---	--	---	t s
$\dagger 7$	45	87	---	--	---	s
10	45	87	---	--	---	p

*In this column, the letters indicate the following motions:

d_1 dived violently - the model stopped abruptly in a nose-down attitude with most of the model submerged

p porpoised - the model undulated about the transverse axis with some part of the model always in contact with the water

s skipped - the model rebounded from the water

t turned sharply - the model pivoted quickly about a vertical axis

\dagger Recommended ditching attitude and flap setting.

Remarks: The tests indicated that the lower turret was the principal cause of diving. It was recommended that this turret be made easily jettisonable.

TABLE 4

SUMMARY OF MODEL-DITCHING INVESTIGATION OF BOMBER D

[Model scale, $\frac{1}{16}$; gross weight, 48,500 lb; center-of-gravity location, 30 percent M.A.C.; all values full scale]

(a) Without hydroflap.

Damage simulated by removal of parts (crosshatched areas)

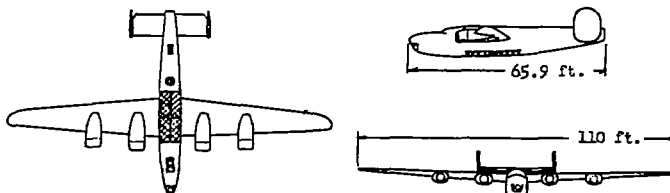

Landing attitude, deg	Flap setting, deg	Landing speed, knots	Length of run, ft	Maximum longitudinal deceleration, g units	Average longitudinal deceleration, g units	Motions of model (*)
Undamaged model						
1	40	104	550	$1\frac{1}{2}$	1	h
			900	$2\frac{1}{2}$	$\frac{1}{2}$	s
5	0	104	950	1	$\frac{1}{2}$	s
			800	1	$\frac{1}{2}$	p
5	40	87	600	$1\frac{1}{2}$	$\frac{1}{2}$	h
			550	$1\frac{1}{2}$	$\frac{1}{2}$	p
9	0	87	300	3	1	h
9	40	87	250	$3\frac{1}{2}$	$1\frac{1}{2}$	h
			550	--	$\frac{1}{2}$	p
Damaged model						
1	40	104	200	--	$2\frac{1}{2}$	d ₁
			300	--	$1\frac{1}{2}$	s
†5	40	87	250	--	$1\frac{1}{2}$	p d ₁
9	40	87	150	--	2	d ₁

*In this column, the letters indicate the following motions:
 d₁ dived violently - the model stopped abruptly in a nose-down attitude with most of the model submerged
 h ran smoothly - the model made a very stable run
 p porpoised - the model undulated about the transverse axis with some part of the model always in contact with water
 s skipped - the model rebounded from the water

†Recommended ditching attitude and flap setting.

Remarks: The bomb-bay doors on this airplane are exceptionally weak and will probably fail in a ditching. The tests of models indicated that failure of the bomb-bay doors caused a diving moment. The amount of damage to the bulkhead aft of the bomb bay determined the severity of the behavior of the airplane.

TABLE 4 - Concluded

SUMMARY OF MODEL-DITCHING INVESTIGATION OF BOMBER D

(b) With hydroflap.

Damage same as shown in three-view sketch. Hydroflap as indicated.

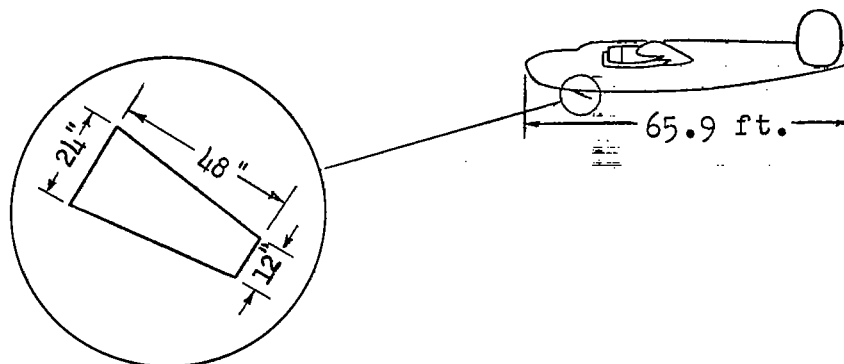

Landing attitude, deg	Flap setting, deg	Landing speed, knots	Length of run, ft	Maximum longitudinal deceleration, g units	Average longitudinal deceleration, g units	Motions of model (*)
1	40	104	450	---	1	P
†6	40	87	300	---	1	P
9	40	87	350	---	1	P

*In this column, the letters indicate the following motions:
 p porpoised - the model undulated about the transverse axis with some part of the model always in contact with water

†Recommended ditching attitude and flap setting.

Remarks: The hydroflap was considered the most practical of several ditching aids which were tested on this model.

TABLE 5

SUMMARY OF MODEL-DITCHING INVESTIGATION OF BOMBER E

[Model scale, $\frac{1}{11}$; gross weight, 26,000 lb; center-of-gravity location, 25 percent M.A.C.; all values full scale]

Damage simulated by removal of parts (crosshatched areas).

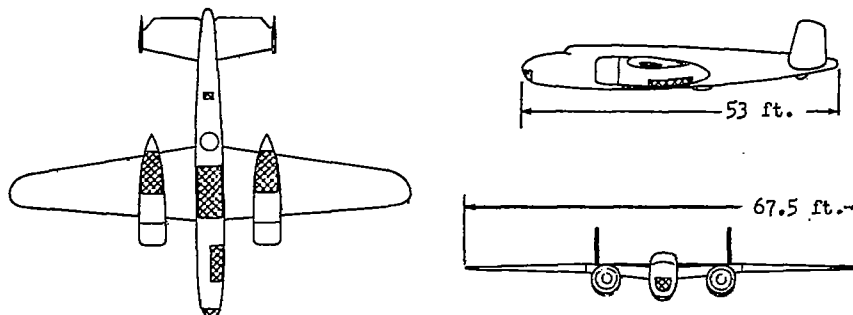

Landing attitude, deg	Flap setting, deg	Landing speed, knots	Length of run, ft	Maximum longitudinal deceleration, g units	Average longitudinal deceleration, g units	Motions of model (*)
Undamaged model						
0	0	104	200	$3\frac{1}{2}$	$2\frac{1}{2}$	h
0	45	104	250	4	2	t
6	0	104	250	3	2	h
6	45	87	150	3	2	h
12	0	104	300	3	$1\frac{1}{2}$	h
12	45	87	200	$3\frac{1}{2}$	$1\frac{1}{2}$	h
Damaged model						
0	45	104	350	$2\frac{1}{2}$	$1\frac{1}{2}$	s
6	45	87	250	3	$1\frac{1}{2}$	b
†12	45	87	150	$3\frac{1}{2}$	2	b

*In this column, the letters indicate the following motions:

- b ran deeply - the model settled deeply into the water with little change in attitude
- h ran smoothly - the model made a very stable run
- s skipped - the model rebounded from the water
- t turned sharply - the model pivoted quickly about a vertical axis

† Recommended ditching attitude and flap setting.

Remarks: The performance of the model was not appreciably changed by simulation of damage. The model ran deeper in the water with the parts removed, but the behavior in general was similar. The large nacelles tended to cause violent turns when one wing was low.

TABLE 6

SUMMARY OF MODEL-DITCHING INVESTIGATION OF BOMBER F

[Model scale, $\frac{1}{12}$; gross weight, 31,000 lb; center-of-gravity location, 14 percent M.A.C.; all values full scale]

Damage simulated by removal of parts (crosshatched areas).

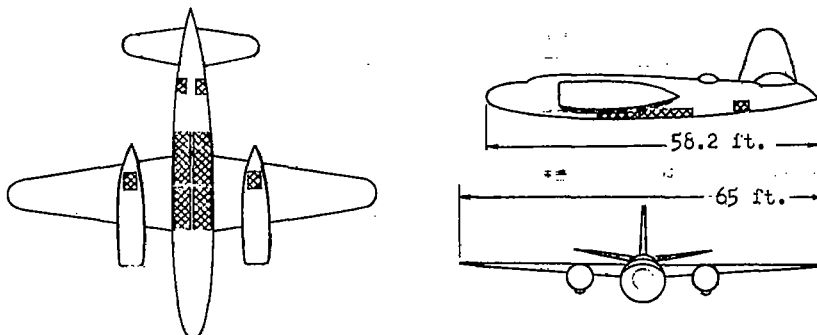

Landing attitude, deg	Flap setting, deg	Landing speed, knots	Length of run, ft	Maximum longitudinal deceleration, g units	Average longitudinal deceleration, g units	Motions of model (*)
Undamaged model						
-1	0	122	400	---	$1\frac{1}{2}$	u h
-1	55	104	400	2	1	u h
6	0	104	350	---	$1\frac{1}{2}$	u h
6	55	104	350	---	$1\frac{1}{2}$	u s
13	0	104	300	---	$1\frac{1}{2}$	h
13	55	104	350	2	$1\frac{1}{2}$	h
Damaged model						
-1	55	104	400	3	1	s
†6	55	104	350	4	$1\frac{1}{2}$	s
13	55	104	300	6	$1\frac{1}{2}$	s

*In this column, the letters indicate the following motions:

- h ran smoothly - the model made a very stable run
- s skipped - the model rebounded from the water
- u trimmed up - the attitude of the model increased while running in the water

†Recommended ditching attitude and flap setting.

Remarks: The model had a trimming-up tendency in the undamaged condition. The large nacelles caused sharp turns when the model was ditched with one wing low.

TABLE 7

SUMMARY OF MODEL-DITCHING INVESTIGATION OF BOMBER G

[Model scale, $\frac{1}{20}$; gross weight, 105,000 lb; center-of-gravity location, 25 percent M.A.C.; all values full scale]

Damage simulated by removal of parts (crosshatched areas).

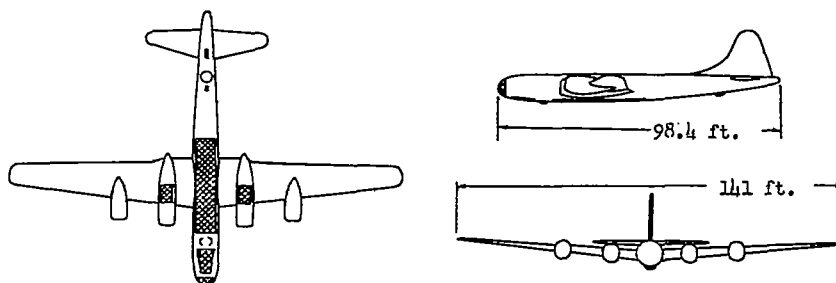

Landing attitude, deg	Flap setting, deg	Landing speed, knots	Length of run, ft	Maximum longitudinal deceleration, g units	Average longitudinal deceleration, g units	Motions of model (*)
Undamaged model						
1	45	122	250	8	$2\frac{1}{2}$	d ₁
5	45	104	650	1	$\frac{1}{2}$	h
9	0	122	850	2	1	h
9	45	87	450	1	$1\frac{1}{2}$	h
13	0	104	700	2	$1\frac{1}{2}$	h
13	45	87	200	$1\frac{1}{2}$	$1\frac{1}{2}$	d ₂
Damaged model						
1	45	122	600	--	1	p
			200	--	$3\frac{1}{2}$	d ₁
5	45	104	350	--	$1\frac{1}{2}$	p
†9	45	87	300	--	1	h
13	45	87	250	--	$1\frac{1}{2}$	h

*In this column, the letters indicate the following motions:
 d₁ dived violently - the model stopped abruptly in a nose-down attitude with most of the model submerged
 d₂ dived slightly - the model stopped abruptly in a nose-down attitude with nose of the model submerged
 h ran smoothly - the model made a very stable run
 p porpoised - the model undulated about the transverse axis with some part of the model always in contact with the water

†Recommended ditching attitude and flap setting.

Remarks: The scale-strength landing flaps on the model did not fail consistently. When the flaps did not fail, the model usually dived.

TABLE 8

SUMMARY OF MODEL-DITCHING INVESTIGATION OF BOMBER B

[Model scale, $\frac{1}{20}$; gross weight, 100,000 lb; center-of-gravity location, 30 percent M.A.C.; all values full scale]

Damage simulated by removal of parts (crosshatched areas).

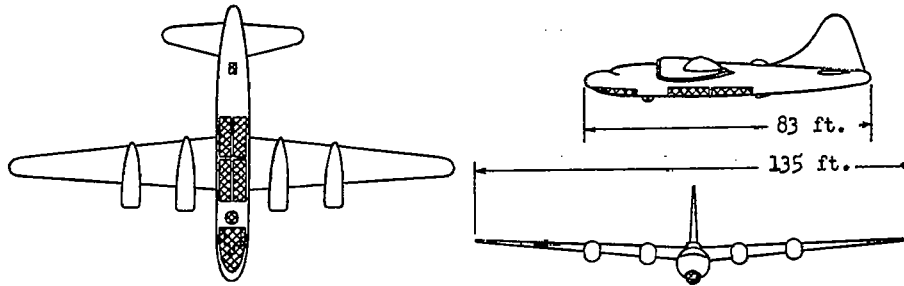

Landing attitude, deg	Flap setting, deg	Landing speed, knots	Length of run, ft	Maximum longitudinal deceleration, g units	Average longitudinal deceleration, g units	Motions of model (*)
Undamaged model						
0	40	122	550	$1\frac{1}{2}$	1	u h b
6	40	102	500	2	1	u h b
13	0	115	600	2	1	h b
13	40	88	450	$1\frac{1}{2}$	1	h b
Damaged model						
0	40	122	450	4	$1\frac{1}{2}$	p b
†6	40	102	350	$4\frac{1}{2}$	$1\frac{1}{2}$	h b
13	40	88	400	$3\frac{1}{2}$	1	h b

*In this column, the letters indicate the following motions:

- b ran deeply - the model settled deeply into the water with little change in attitude
- h ran smoothly - the model made a very stable run
- p porpoised - the model undulated about the transverse axis with some part of the model always in contact with the water
- u trimmed up - the attitude of the model increased while running in the water

† Recommended ditching attitude and flap setting.

Remarks: Decelerations were increased when damage was simulated, but the behavior of the model was not appreciably changed.

TABLE 9

SUMMARY OF MODEL-DITCHING INVESTIGATION OF BOMBER T

[Model scale, $\frac{1}{20}$; gross weight, 150,000 lb; center-of-gravity location, 25 percent M.A.C.; all values full scale]

Damage simulated by removal of parts (crosshatched areas).

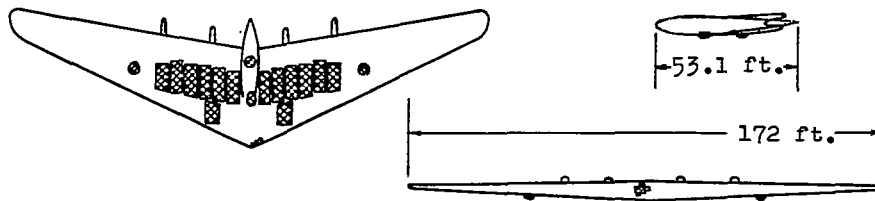

Landing attitude, deg	Flap setting, deg	Landing speed, knots	Length of run, ft	Maximum longitudinal deceleration, g units	Average longitudinal deceleration, g units	Motions of model (*)
Undamaged model						
9	50	111	400	--	$1\frac{1}{2}$	h t p t
Damaged model						
4	50	124	500	5	$1\frac{1}{2}$	u p t
†9	50	111	300	5	2	u p
9	50	111	300	6	2	u p t
14	50	98	250	6	$1\frac{1}{2}$	b
14	50	98	250	7	$1\frac{1}{2}$	b t

*In this column, the letters indicate the following motions:
 b ran deeply - the model settled deeply into the water with little change in attitude
 h ran smoothly - the model made a very stable run
 p porpoised - the model undulated about the transverse axis with some part of the model always in contact with the water
 t turned sharply - the model pivoted quickly about a vertical axis
 u trimmed up - the attitude of the model increased while running in the water
 †Recommended ditching attitude and flap setting.

Remarks: The most pronounced ditching characteristic of this bomber model was its tendency to turn or yaw. Construction of the airplane is such that extensive damage is to be expected and it probably will be difficult to find ditching stations where crew members can adequately brace themselves and be reasonably sure of avoiding an inrush of water.

TABLE 10

SUMMARY OF MODEL-DITCHING INVESTIGATION OF BOMBER J

[Model scale, $\frac{1}{20}$ and $\frac{1}{30}$; gross weight, 255,000 lb; center-of-gravity location, 29 percent M.A.C; all values full scale]

Damage simulated by removal of parts (crosshatched area).

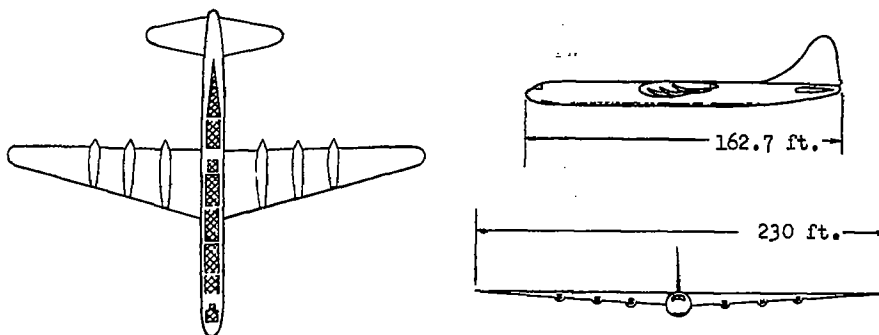

Landing attitude, deg	Flap setting, deg	Landing speed, knots	Length of run, ft	Maximum longitudinal deceleration, g units	Average longitudinal deceleration, g units	Motions of model (*)
Undamaged 1/30-scale model						
1	40	124	1,000	---	$\frac{1}{2}$	u h
1	40	124	1,000	---	$\frac{1}{2}$	u s
5	40	106	650	---	1	h
9	0	119	650	---	1	h
9	40	95	1,000	---	$\frac{1}{2}$	h
13	0	108	1,000	---	$\frac{1}{2}$	p
13	40	87	650	---	$\frac{1}{2}$	h
Damaged 1/20-scale model						
1	40	124	-----	4	--	b
†9	40	95	-----	2	--	h

*In this column, the letters indicate the following motions:

- b ran deeply - the model settled deeply into the water with little change in attitude
- h ran smoothly - the model made a very stable run
- p porpoised - the model undulated about the transverse axis with some part of the model always in contact with the water
- s skipped - the model rebounded from the water
- u trimmed up - the attitude of the model increased while running in the water

† Recommended ditching attitude and flap setting.

Remarks: The behavior of the model was generally good. No violent motions such as diving occurred, and the maximum longitudinal deceleration recorded was about 4g.

TABLE 11

SUMMARY OF MODEL-DITCHING INVESTIGATION OF BOMBER K

[Model scale, $\frac{1}{18}$; gross weight, 82,600 lb; center-of-gravity location, 29 percent M.A.C.; all values full scale]

(a) Without hydroflap.

Damage simulated by removal of parts and covering of openings with aluminum foil (hatched areas).

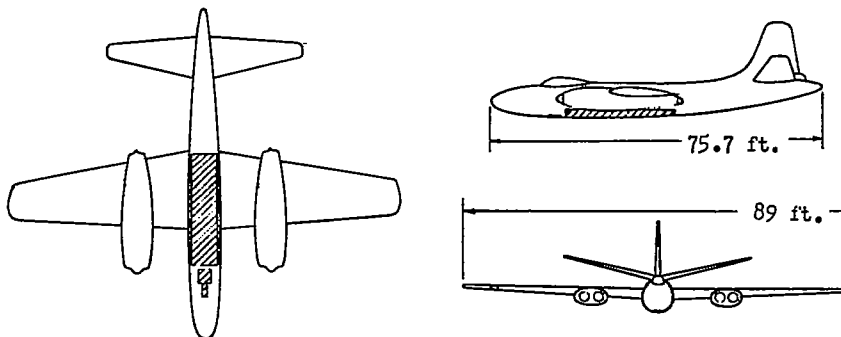

Landing attitude, deg	Flap setting, deg	Landing speed, knots	Length of run, ft	Maximum longitudinal deceleration, g units	Average longitudinal deceleration, g units	Motions of model (*)
Undamaged model						
2	40	131	950	$1\frac{1}{2}$	1	u h
6	40	119	850	1	$\frac{1}{2}$	u h
Damaged model						
2	40	131	200	$9\frac{1}{2}$	4	d ₁
†6	40	119	300	5	2	d ₁

*In this column, the letters indicate the following motions:
 d₁ dived violently - the model stopped abruptly in a nose-down attitude with most of the model submerged
 h ran smoothly - the model made a very stable run
 u trimmed up - the attitude of the model increased while running in the water

†Recommended ditching attitude and flap setting.

Remarks: The scale-strength bomb-bay doors and nose-wheel doors consistently failed on the model. The dives that occurred were very violent. Additional data have indicated that if the bulkhead and part of the fuselage bottom aft of the bomb bay fail in a ditching, diving may not occur.

TABLE 11.- Concluded

SUMMARY OF MODEL-DITCHING INVESTIGATION OF BOMBER K

(b) With hydroflap.

Damage same as shown in three-view sketch. Hydroflap as indicated.

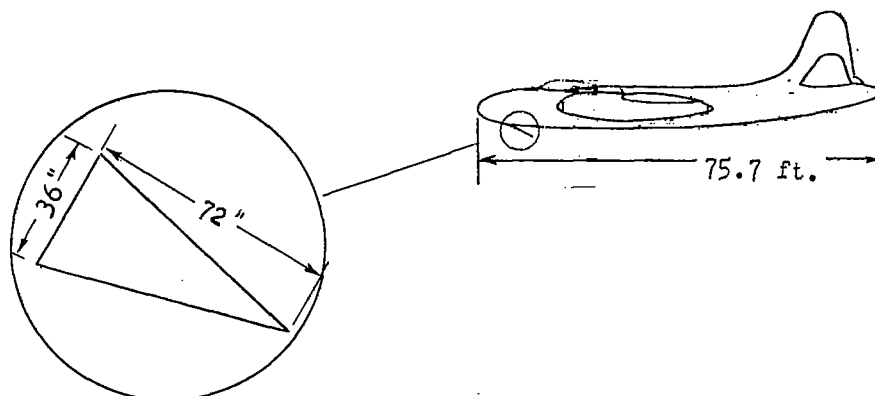

Landing attitude, deg	Flap setting, deg	Landing speed, knots	Length or run, ft	Maximum longitudinal deceleration, g units	Average longitudinal deceleration, g units	Motions of model (*)
2	40	131	720	$3\frac{1}{2}$	1	s p
+6	40	119	540	$3\frac{1}{2}$	1	s p

*In this column, the letters indicate the following motions:

- p porpoised - the model undulated about the transverse axis with some part of the model always in contact with the water
 s skipped - the model rebounded from the water

| Recommended ditching attitude and flap setting.

Remarks: The hydroflap stopped the diving and reduced the deceleration. It also kept the nose-wheel doors from failing.

TABLE 12

SUMMARY OF MODEL-DITCHING INVESTIGATION OF BOMBER L

[Model scale, $\frac{1}{24}$; gross weight, 125,000 lb; center-of-gravity location, 20 percent M.A.C.; all values full scale]

Damage simulated by removal of parts and covering of openings with aluminum foil (hatched areas).

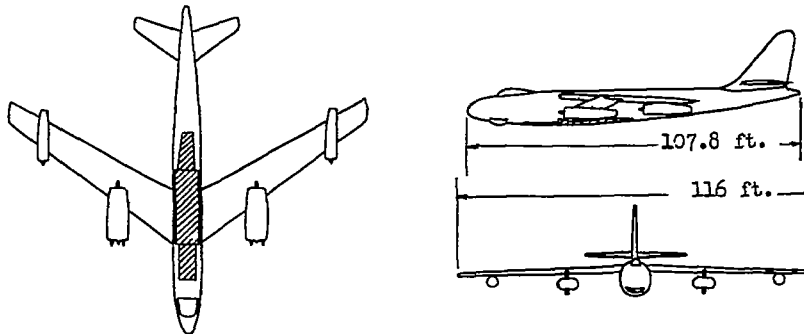

Landing attitude, deg	Flap setting, deg	Landing speed, knots	Length of run, ft	Maximum longitudinal deceleration, g units	Average longitudinal deceleration, g units	Motions of model (*)
Undamaged model						
5	35	134	650	2	1	u s p
10	0	155	700	3	$1\frac{1}{2}$	h
10	35	120	650	2	1	h
15	35	115	550	$1\frac{1}{2}$	1	h
Damaged model						
5	35	134	650	3	1	b
†10	35	120	550	$2\frac{1}{2}$	1	h
15	35	115	450	3	$1\frac{1}{2}$	b

*In this column, the letters indicate the following motions:
 b ran deeply - the model settled deeply into the water with little change in attitude
 h ran smoothly - the model made a very stable run
 p porpoised - the model undulated about the transverse axis with some part of the model always in contact with the water
 s skipped - the model rebounded from the water
 u trimmed up - the attitude of the model increased while running in the water
 †Recommended ditching attitude and flap setting.

Remarks: Additional tests with the nacelles attached at scale strength indicated that the nacelles will probably be torn off in a ditching but will have little or no effect on behavior. The simulated main-wheel doors failed.

TABLE 13

SUMMARY OF MODEL-DITCHING INVESTIGATION OF BOMBER M

[Model scale, $\frac{1}{11}$; gross weight, 26,500 lb; center-of-gravity location, 30 percent M.A.C; all values full scale]

Damage simulated by removal of part (crosshatched area).

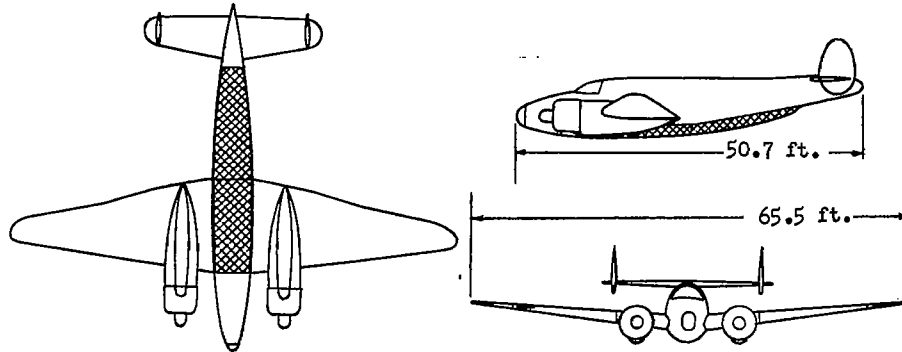

Landing attitude, deg	Flap setting, deg	Landing speed, knots	Length of run, ft	Maximum longitudinal deceleration, g units	Average longitudinal deceleration, g units	Motions of model (*)
Undamaged model						
2	38	113	450	4	1	s p
7	0	122	650	--	1	s t
7	38	87	450	$1\frac{1}{2}$	1	p
12	0	104	700	1	1	h
12	38	87	350	2	1	h
Damaged model						
2	38	122	400	--	$1\frac{1}{2}$	s p
7	38	87	300	--	1	p
†12	38	87	300	--	1	p

*In this column, the letters indicate the following motions:

- h ran smoothly - the model made a very stable run
- p porpoised - the model undulated about the transverse axis with some part of the model always in contact with the water
- s skipped - the model rebounded from the water
- t turned sharply - the model pivoted quickly about a vertical axis

†Recommended ditching attitude and flap setting.

Remarks: From examination of full-scale ditching reports on this airplane, it is believed that the fuselage bottom section aft of the bomb bay will be torn away in a ditching with the results indicated above. If this section does not fall, violent dives occur.

TABLE 14

SUMMARY OF MODEL-DITCHING INVESTIGATION OF BOMBER N

[Model scale, $\frac{1}{16}$; gross weight, 45,000 lb; center-of-gravity location, 29 percent M.A.C.; all values full scale]

(a) Without hydroflap or hydro-skis.

Damage simulated by removal of parts (crosshatched areas).

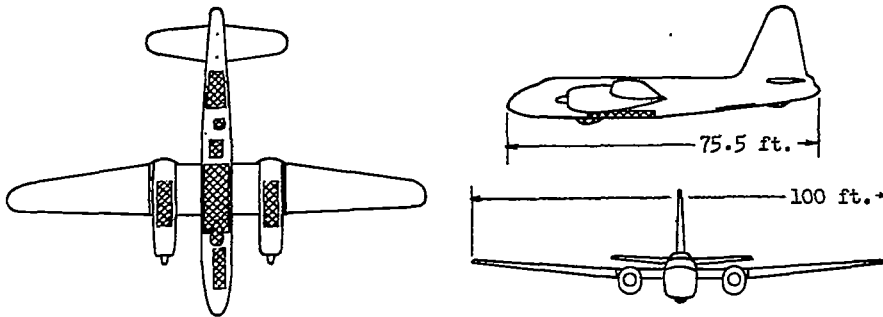

Landing attitude, deg	Flap setting, deg	Landing speed, knots	Length of run, ft	Maximum longitudinal deceleration, g units	Average longitudinal deceleration, g units	Motions of model (*)
Undamaged model						
2	32	89	400	2	1	u h
6	0	121	700	2	1	h
6	32	78	300	2	1	h
10	0	102	550	$1\frac{1}{2}$	1	h
10	32	71	300	2	1	h
Damaged model						
2	32	89	150	6	$2\frac{1}{2}$	d ₁
†6	32	78	150	4	2	d ₁
10	32	71	100	$3\frac{1}{2}$	$2\frac{1}{2}$	d ₁

*In this column, the letters indicate the following motions:
 d₁ dived violently - the model stopped abruptly in a nose-down attitude with most of the model submerged
 h ran smoothly - the model made a very stable run
 u trimmed up - the attitude of the model increased while running in the water

†Recommended ditching attitude and flap setting.

Remarks: Data obtained from the manufacturer indicates that the fuselage bottom is extremely weak so that considerable damage with this airplane could be expected. The diving caused by simulated damage was very violent.

TABLE 14.- Continued

SUMMARY OF MODEL-DITCHING INVESTIGATION OF BOMBER N

(b) With hydroflap.

Damage same as shown in three-view sketch except nose-wheel doors not removed. Hydroflap as indicated.

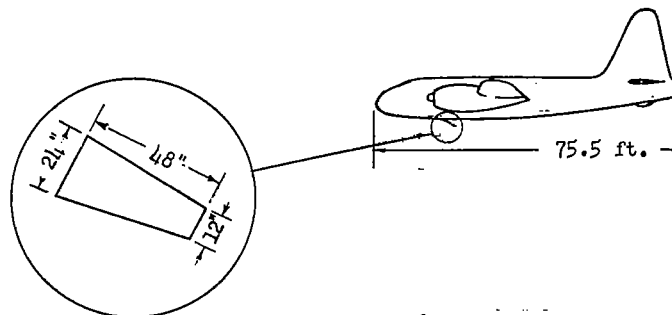

Landing attitude, deg	Flap setting, deg	Landing speed, knots	Length of run, ft	Maximum longitudinal deceleration, g units	Average longitudinal deceleration, g units	Motions of model (*)
2	32	89	450	3	1	p h
†6	32	78	300	$3\frac{1}{2}$	1	p h
10	32	71	250	4	1	p h

*In this column, the letters indicate the following motions:

- h ran smoothly - the model made a very stable run
- p porpoised - the model undulated about the transverse axis with some part of the model always in contact with water

†Recommended ditching attitude and flap setting.

Remarks: The location of the hydroflap on this airplane was critical. When located forward of the nose-wheel doors, it did not stop the diving.

TABLE 14.- Concluded

SUMMARY OF MODEL-DITCHING INVESTIGATION OF BOMBER N

(c) With hydro-skis.

No damage simulated. Skis as indicated.

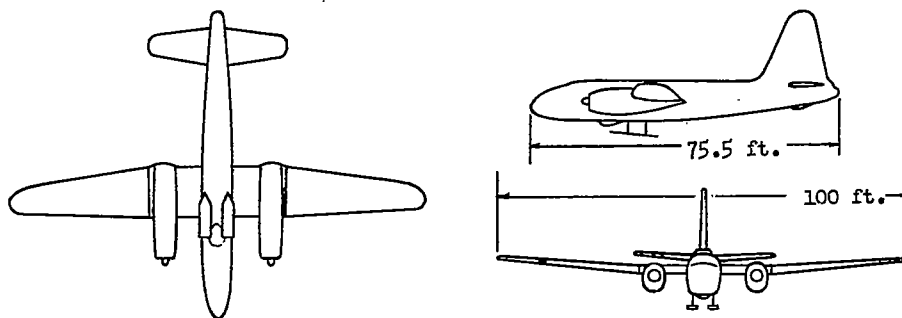

Landing attitude, deg	Flap setting, deg	Landing speed, knots	Length of run, ft	Maximum longitudinal deceleration, g units	Average longitudinal deceleration, g units	Motions of model (*)
2	32	89	1,350	1	$\frac{1}{2}$	h
6	32	78	950	--	$\frac{1}{2}$	h
10	32	71	500	$\frac{1}{2}$	$\frac{1}{2}$	h

*In this column, the letters indicate the following motions:
 h ran smoothly - the model made a very stable run

Remarks: The ditching behavior with the hydro-skis was very good. It is possible that critical damage can be eliminated from ditchings by using a hydro-ski ditching gear, and thus the chances of survival and rescue would be greatly increased.

TABLE 15

SUMMARY OF MODEL-DITCHING INVESTIGATION OF BOMBER O

[Model scale, $\frac{1}{18}$; gross weight, 55,000 lb; center-of-gravity location, 22 percent M.A.C.; all values full scale]

(a) Without hydroflap.

Damage simulated by removal of parts (crosshatched areas).

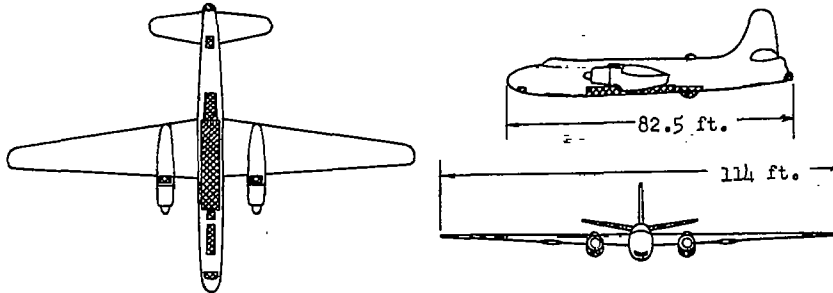

Landing attitude, deg	Flap setting, deg	Landing speed, knots	Length of run, ft	Maximum longitudinal deceleration, g units	Average longitudinal deceleration, g units	Motions of model (*)
Undamaged model						
1	40	98	300	--	$1\frac{1}{2}$	h
7	0	108	400	--	$1\frac{1}{2}$	p
7	40	88	300	--	1	p
13	0	98	300	--	$1\frac{1}{2}$	h
13	40	82	300	--	1	h
Damaged model						
1	40	95	100	$4\frac{1}{2}$	4	d ₂
†7	40	89	200	3	2	p
†7	40	89	100	$4\frac{1}{2}$	$3\frac{1}{2}$	d ₂
13	40	82	150	$3\frac{1}{2}$	2	d ₂
13	40	82	150	$3\frac{1}{2}$	2	t

*In this column, the letters indicate the following motions:
d₂ dived slightly - the model stopped abruptly in a nose-down attitude with the nose of the model submerged
h ran smoothly - the model made a very stable run
p porpoised - the model undulated about the transverse axis with some part of the model always in contact with the water
t turned sharply - the model pivoted quickly about a vertical axis
†Recommended ditching attitude and flap setting.

Remarks: The behavior of the damaged model varied inconsistently.

TABLE 15.- Concluded

SUMMARY OF MODEL-DITCHING INVESTIGATION OF BOMBER O

(b) With hydroflap.

Damage same as shown in three-view sketch. Navigator's escape hatch (open at an angle of 30° to the thrust line) used as hydroflap.

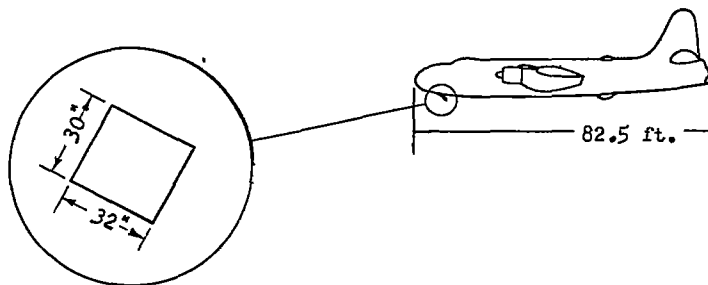

Landing attitude, deg	Flap setting, deg	Landing speed, knots	Length of run, ft	Maximum longitudinal deceleration, g units	Average longitudinal deceleration, g units	Motions of model (*)
1	40	95	150	3	2½	P
†7	40	85	150	2½	2	P
13	40	82	150	3	2	P

*In this column, the letters indicate the following motions:
 p porpoised - the model undulated about the transverse axis with some part of the model always in contact with water

†Recommended ditching attitude and flap setting.

Remarks: The hydroflap is recommended as a ditching aid on this airplane to stop the diving that sometimes occurred. It also reduced the decelerations slightly.

TABLE 16

SUMMARY OF MODEL-DITCHING INVESTIGATION OF BOMBER P

[Model scale, $\frac{1}{8}$; gross weight, 13,060 lb; center-of-gravity location, 30 percent M.A.C.; all values full scale]

Damage simulated by removal of parts (crosshatched areas).

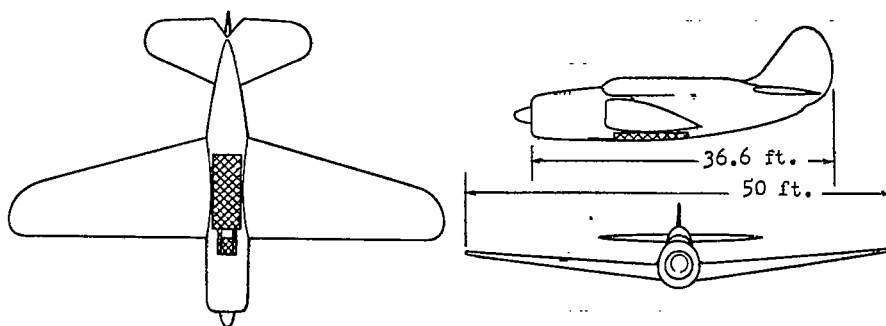

Landing attitude, deg	Flap setting, deg	Landing speed, knots	Length of run, ft	Maximum longitudinal deceleration, g units	Average longitudinal deceleration, g units	Motions of model (*)
Damaged model						
2	30	113	150	8	4	d ₁
2	60	104	100	5 $\frac{1}{2}$	5	d ₁
2	60	104	---	---	---	s
8	0	113	400	6 $\frac{1}{2}$	1 $\frac{1}{2}$	s
8	0	113	---	---	---	p
8	30	95	200	5	2	d ₁
8	60	87	150	7	2	d ₁
8	60	87	---	---	---	s
15	0	87	200	4 $\frac{1}{2}$	1 $\frac{1}{2}$	d ₁
15	0	87	---	---	---	b
15	30	78	150	5	2	d ₁
15	60	69	200	4	1	d ₁
15	60	69	---	---	---	s b

*In this column, the letters indicate the following motions:

- b ran deeply - the model settled deeply into the water with little change in attitude
- d₁ dived violently - the model stopped abruptly in a nose-down attitude with most of the model submerged
- p porpoised - the model undulated about the transverse axis with some part of the model always in contact with the water
- s skipped - the model rebounded from the water

Remarks: The landing flaps were very strong on this scout bomber. When they failed, the model skipped or made a deep run; when they did not fail, the model dived.

TABLE 17

SUMMARY OF MODEL-DITCHING INVESTIGATION OF BOMBER Q

[Model scale, $\frac{1}{9}$; gross weight, 13,795 lb; center-of-gravity location, 26 percent M.A.C.; all values full scale]

Damage simulated by removal of parts (crosshatched areas).

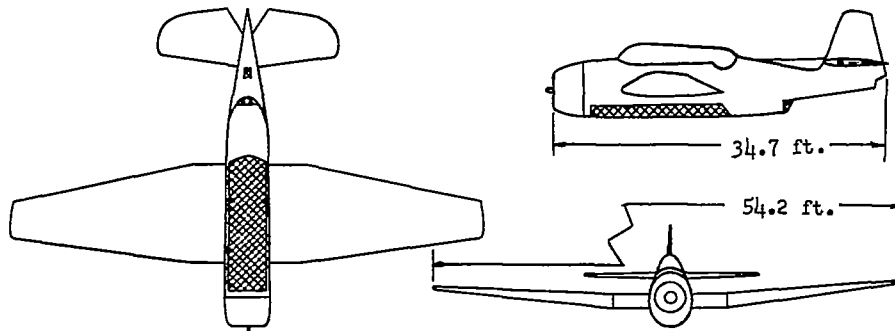

Landing attitude, deg	Flap setting, deg	Landing speed, knots	Length of run, ft	Maximum longitudinal deceleration, g units	Average longitudinal deceleration, g units	Motions of model (*)
Undamaged model						
3	45	80	500	--	$\frac{1}{2}$	p h
7	0	86	550	--	$\frac{1}{2}$	s h
7	45	76	400	2	$\frac{1}{2}$	p h
11	0	85	500	$\frac{1}{2}$	$\frac{1}{2}$	p h
11	45	68	450	1	$\frac{1}{2}$	p h
Damaged model						
3	45	77	100	$\frac{4}{2}$	$\frac{2}{2}$	d ₁
†7	45	76	150	$\frac{3}{2}$	$\frac{1}{2}$	d ₁
11	45	66	100	--	2	d ₁

*In this column, the letters indicate the following motions:

- d₁ dived violently - the model stopped abruptly in a nosedown attitude with most of the model submerged
- h ran smoothly - the model made a very stable run
- p porpoised - the model undulated about the transverse axis with some part of the model always in contact with the water
- s skipped - the model rebounded from the water

†Recommended ditching attitude and flap setting.

Remarks: Full-scale reports have indicated that all personnel aboard this airplane have a good chance to survive a ditching, and if the radioman moves to the upper part of the fuselage, his chances will be improved.

TABLE 18

SUMMARY OF MODEL-DITCHING INVESTIGATION OF BOMBER R

[Model scale, $\frac{1}{9}$; gross weight, 16,925 lb; center-of-gravity location, 32 percent M.A.C.; all values full scale]

Damage simulated by removal of parts (crosshatched areas).

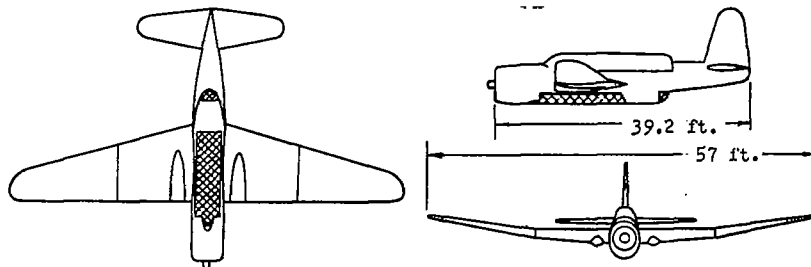

Landing attitude, deg	Flap setting, deg	Landing speed, knots	Length of run, ft	Maximum longitudinal deceleration, g units	Average longitudinal deceleration, g units	Motions of model (*)
Undamaged model						
2	50	96	600	---	$1\frac{1}{2}$	s
7	0	108	800	---	$1\frac{1}{2}$	s
7	50	85	500	---	$1\frac{1}{2}$	s
12	0	89	550	---	$1\frac{1}{2}$	p
12	50	78	550	---	$1\frac{1}{2}$	p
18	0	85	500	---	$1\frac{1}{2}$	s p
18	50	71	450	---	$1\frac{1}{2}$	p h
Damaged model						
2	50	100	80	---	$5\frac{1}{2}$	d ₁
7	50	87	100	---	$3\frac{1}{2}$	d ₁
†12	50	78	100	---	$2\frac{1}{2}$	d ₁
18	50	71	100	---	2	d ₁

*In this column, the letters indicate the following motions:

- d₁ dived violently - the model stopped abruptly in a nose-down attitude with most of the model submerged
 h ran smoothly - the model made a very stable run
 p porpoised - the model undulated about the transverse axis with some part of the model always in contact with the water
 s skipped - the model rebounded from the water

†Recommended ditching attitude and flap setting.

Remarks: This airplane closely resembles bomber Q. The ditching behavior of the models was similar, but the higher landing speeds of bomber Q gave higher average decelerations.

TABLE 19

SUMMARY OF MODEL-DITCHING INVESTIGATION OF FIGHTER A

[Model scale, $\frac{1}{10}$; gross weight, 12,151 lb; center-of-gravity location, 23 percent M.A.C.; all values full scale]

Damage simulated by removal of parts (crosshatched areas) and installation of crumpled parts (dotted areas).

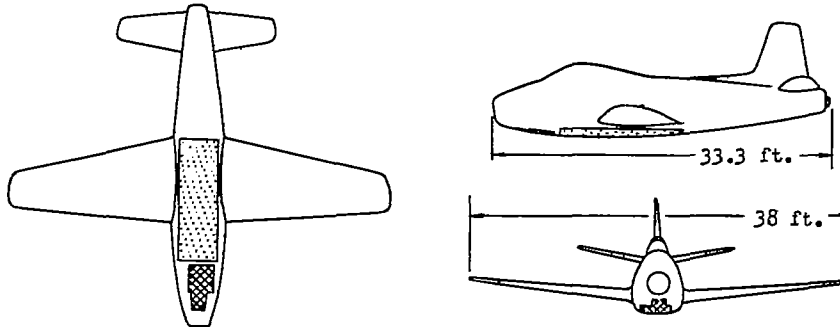

Landing attitude, deg	Flap setting, deg	Landing speed, knots	Length of run, ft	Maximum longitudinal deceleration, g units	Average longitudinal deceleration, g units	Motions of model (*)
Undamaged model						
2	40	128	650	$9\frac{1}{2}$	1	u s d ₁
8	40	104	1,000	4	$\frac{1}{2}$	u s h
12	0	118	900	6	$\frac{1}{2}$	u s p
12	40	94	700	$2\frac{1}{2}$	$\frac{1}{2}$	u s p h
Damaged model						
2	40	128	900	5	1	u s h
8	40	104	700	3	$\frac{1}{2}$	u s p h
[†] 12	40	94	600	$2\frac{1}{2}$	$\frac{1}{2}$	h u p h

*In this column, the letters indicate the following motions:

- d₁ dived violently - the model stopped abruptly in a nose-down attitude with most of the model submerged
- h ran smoothly - the model made a very stable run
- p porpoised - the model undulated about the transverse axis with some part of the model always in contact with the water
- s skipped - the model rebounded from the water
- u trimmed up - the attitude of the model increased while running in the water

[†]Recommended ditching attitude and flap setting.

Remarks: The undamaged model trimmed up and skipped violently when it contacted the water. Simulation of damage improved the ditching behavior by reducing the trimming up and skipping.

TABLE 20

SUMMARY OF MODEL-DITCHING INVESTIGATION OF FIGHTER B

[Model scale, $\frac{1}{12}$; gross weight, 25,000 lb; center-of-gravity location, 22 percent M.A.C.; all values full scale]

Damage simulated by removal of parts (crosshatched areas) and installation of crumpled parts (dotted areas).

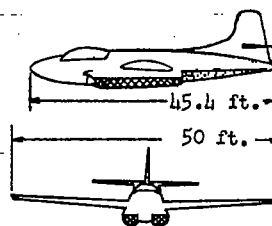
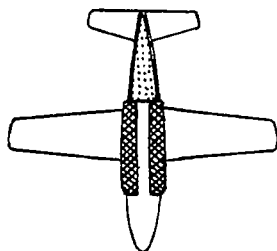

Landing attitude, deg	Flap setting, deg	Landing speed, knots	Length of run, ft	Maximum longitudinal deceleration, g units	Average longitudinal deceleration, g units	Motions of model (*)
Undamaged model						
4	40	127	550	--	$1\frac{1}{2}$	s t
8	0	139	1,150	5	$1\frac{1}{2}$	s p
8	40	111	600	2	1	u h
12	0	122	1,200	$4\frac{1}{2}$	$1\frac{1}{2}$	s p
12	40	101	650	2	$1\frac{1}{2}$	u o
Damaged model						
4	40	127	650	--	1	s p
8	0	139	600	11	$1\frac{1}{2}$	h
†8	40	111	550	2	1	h
12	0	122	550	5	1	h
12	40	101	500	3	1	h

*In this column, the letters indicate the following motions:

- h ran smoothly - the model made a very stable run
- o oscillated - the model oscillated about the longitudinal or vertical axis
- p porpoised - the model undulated about the transverse axis with some part of the model always in contact with the water
- s skipped - the model rebounded from the water
- t turned sharply - the model pivoted quickly about a vertical axis
- u trimmed up - the attitude of the model increased while running in the water

†Recommended ditching attitude and flap setting.

Remarks: The jet engines located below the fuselage did not cause diving in this installation, but a very high maximum longitudinal deceleration was obtained at one condition. Simulation of damage stopped the model from trimming up.

TABLE 21

SUMMARY OF MODEL-DITCHING INVESTIGATION OF FIGHTER C

[Model scale, $\frac{1}{8}$; gross weight, 9,706 lb; center-of-gravity location, 31 percent M.A.C.; all values full scale]

Damage simulated by use of scale-strength parts (hatched areas) and removal of other parts (crosshatched areas).

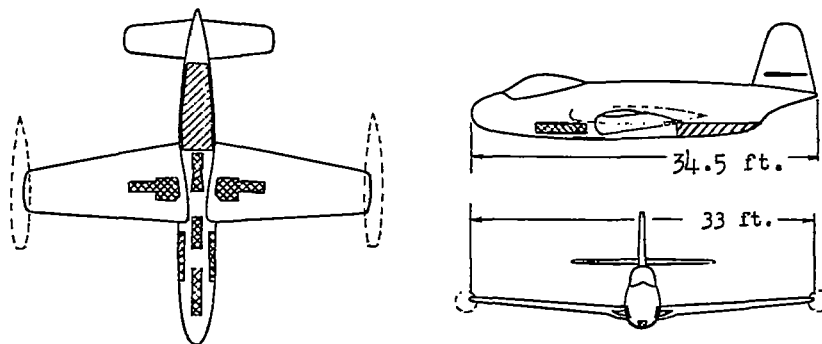

Landing attitude, deg	Flap setting, deg	Landing speed, knots	Length of run, ft	Maximum longitudinal deceleration, g units	Average longitudinal deceleration, g units	Motions of model (*)
Undamaged model						
4	27	124	500	2	$1\frac{1}{2}$	u s p
8	27	107	550	1	1	u s p
12	27	97	400	2	1	u p
Damaged model						
4	27	124	200	9	$3\frac{1}{2}$	p d ₂
8	27	107	150	10	$3\frac{1}{2}$	d ₁
† ₁₂	27	97	100	7	4	d ₁

*In this column, the letters indicate the following motions:

- d₁ dived violently - the model stopped abruptly in a nose-down attitude with most of the model submerged
- d₂ dived slightly - the model stopped abruptly in a nose-down attitude with the nose of the model submerged
- p porpoised - the model undulated about the transverse axis with some part of the model always in contact with the water
- s skipped - the model rebounded from the water
- u trimmed up - the attitude of the model increased while running in the water

†Recommended ditching attitude and flap setting.

Remarks: The trimming up and diving of this model was extremely severe. The pilot should make sure that the safety harness is securely fastened in order to withstand the decelerations.

TABLE 22

SUMMARY OF MODEL-DITCHING INVESTIGATION OF FIGHTER D

[Model scale, $\frac{1}{11}$; gross weight, 22,800 lb; center-of-gravity location, 12 percent M.A.C.; all values full scale]

Damage simulated by removal of parts (crosshatched areas) and installation of crumpled parts (dotted areas).

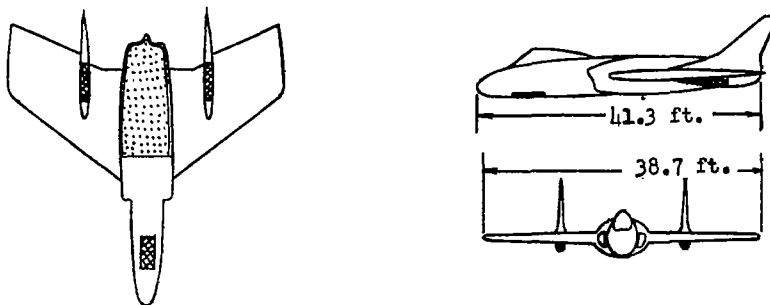

Landing attitude, deg	Ailavator setting, deg	Landing speed, knots	Length of run, ft	Maximum longitudinal deceleration, g units	Average longitudinal deceleration, g units	Motions of model (*)
Undamaged model						
18	-20	131	940	--	1	u s
23	-30	117	870	2	$\frac{1}{2}$	s p
28	-40	106	720	$1\frac{1}{2}$	$\frac{1}{2}$	s p
Damaged model						
18	-20	131	600	--	$1\frac{1}{2}$	u s
23	-30	117	540	$3\frac{1}{2}$	1	s p
28	-40	106	500	$3\frac{1}{2}$	1	p

*In this column, the letters indicate the following motions:

- p porpoised - the model undulated about the transverse axis with some part of the model always in contact with the water
- s skipped - the model rebounded from the water
- u trimmed up - the attitude of the model increased while running in the water

Remarks: The airplane can land at extremely high attitudes and should be ditched at the lowest speed and highest attitude consistent with adequate control.

TABLE 23

SUMMARY OF MODEL-DITCHING INVESTIGATION OF FIGHTER E

[Model scale, $\frac{1}{10}$; gross weight, 13,311 lb; center-of-gravity location, 22 percent M.A.C.; all values full scale]

Damage simulated by installation of crumpled part (dotted area).

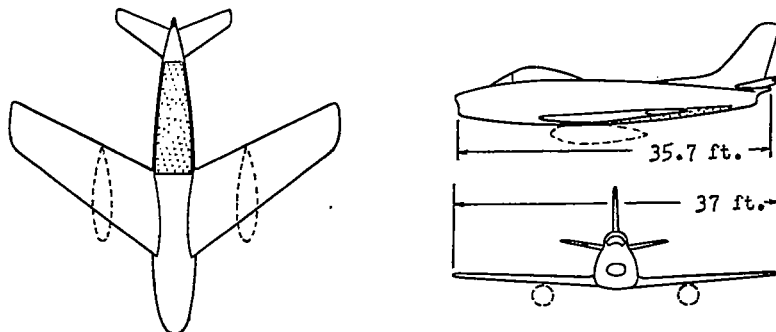

Landing attitude, deg	Flap setting, deg	Landing speed, knots	Length of run, ft	Maximum longitudinal deceleration, g units	Average longitudinal deceleration, g units	Motions of model. (*)
Undamaged model						
4	38	132	300	8	$2\frac{1}{2}$	d ₁
9	38	109	800	1	$1\frac{1}{2}$	h
14	0	113	700	$2\frac{1}{2}$	1	p s
14	38	98	650	$1\frac{1}{2}$	$1\frac{1}{2}$	h
Damaged model						
4	38	132	200	$7\frac{1}{2}$	4	d ₁
9	38	109	600	3	1	h
†14	38	98	600	3	$1\frac{1}{2}$	h

*In this column, the letters indicate the following motions:
 d₁ dived violently - the model stopped abruptly in a nose-down attitude with most of the model submerged
 h ran smoothly - the model made a very stable run
 p porpoised - the model undulated about the transverse axis with some part of the model always in contact with the water
 s skipped - the model rebounded from the water

†Recommended ditching attitude and flap setting.

Remarks: Extreme care should be taken to avoid the violent dive at the low attitude. The tanks under the wing should be jettisoned before ditching.

TABLE 24

SUMMARY OF MODEL-DITCHING INVESTIGATION OF FIGHTER F

[Model scale, $\frac{1}{10}$; gross weight, 12,100 lb; center-of-gravity location, 27 percent M.A.C.; all values full scale]

(a) Without hydroflap.

Damage simulated by installation of crumpled part (dotted area).

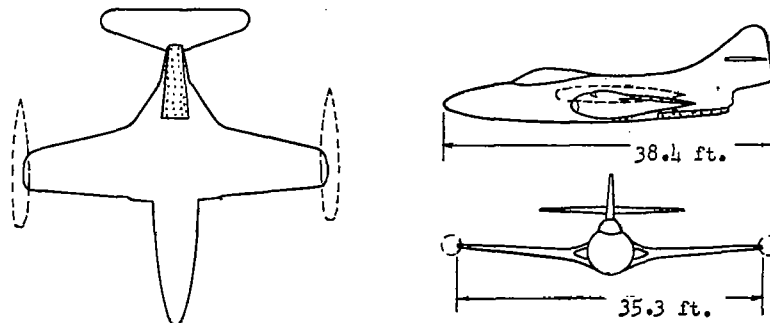

Landing attitude, deg	Flap setting, deg	Landing speed, knots	Length of run, ft	Maximum longitudinal deceleration, g units	Average longitudinal deceleration, g units	Motions of model (*)
Undamaged model						
4	Inboard 20 Outboard 55	133	740	5	1	s p
8	Inboard 20 Outboard 55	115	760	3	1	s p
12	Inboard 20 Outboard 55	102	590	2	1	s p
Damaged model						
4	Inboard 20 Outboard 55	133	760	5	1	s p
8	Inboard 20 Outboard 55	115	685	3	1	s p
†12	Inboard 20 Outboard 55	102	700	2	$\frac{1}{2}$	s p

*In this column, the letters indicate the following motions:
 p porpoised - the model undulated about the transverse axis with some part of the model always in contact with the water
 s skipped - the model rebounded from the water

†Recommended ditching attitude and flap setting.

Remarks: This model made rather long runs with severe skipping.

TABLE 24.- Concluded

SUMMARY OF MODEL-DITCHING INVESTIGATION OF FIGHTER F

(b) With hydroflap.

Damage same as shown on three-view sketch. Speed brake (open at angle of 30° to thrust line) used as hydroflap.

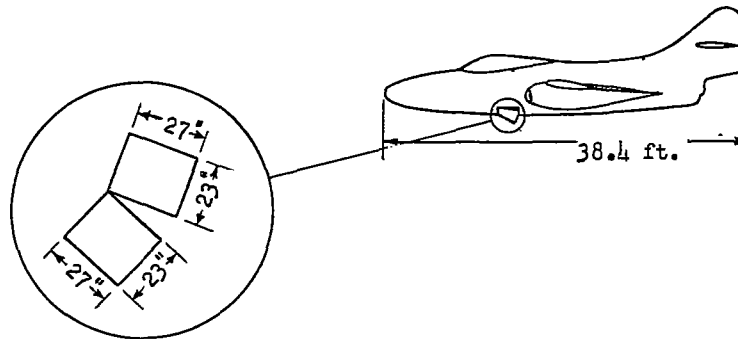

Landing attitude, deg	Flap setting, deg	Landing speed, knots	Length of run, ft	Maximum longitudinal deceleration, g units	Average longitudinal deceleration, g units	Motions of model (*)
8	Inboard 20 Outboard 55	115	765	2	1	s p
[†] 12	Inboard 20 Outboard 55	102	595	2	1	p s p

* In this column, the letters indicate the following motions:

p porpoised - the model undulated about the transverse axis with some part of the model always in contact with the water

s skipped - the model rebounded from the water

[†] Recommended ditching attitude and flap setting.

Remarks: The severity of the skipping was reduced by using the hydroflap.

TABLE 25

SUMMARY OF MODEL-DITCHING INVESTIGATION OF FIGHTER G

[Model scale, $\frac{1}{9}$; gross weight, 14,900 lb; center-of-gravity location, 28 percent M.A.C.; all values full scale]

Damage simulated by removal of parts (crosshatched areas).

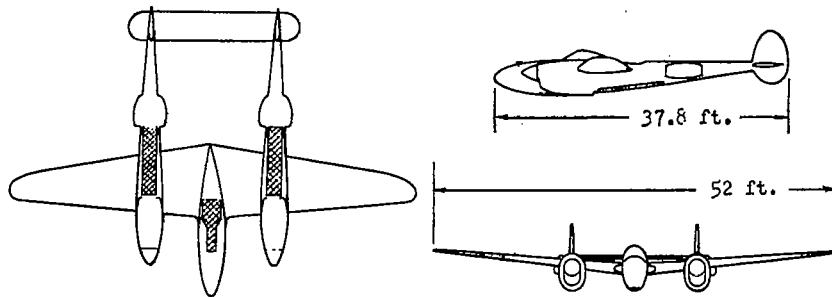

Landing attitude, deg	Flap setting, deg	Landing speed, knots	Length of run, ft	Maximum longitudinal deceleration, g units	Average longitudinal deceleration, g units	Motions of model (*)
Undamaged model						
5	37	100	250	6	2	s
9	0	115	250	---	$2\frac{1}{2}$	b
9	37	88	200	4	$1\frac{1}{2}$	s o
13	0	100	250	8	2	b
13	37	79	200	---	$1\frac{1}{2}$	s
Damaged model						
2	37	113	100	---	$5\frac{1}{2}$	s d ₂
5	37	100	200	---	2	s
†9	37	88	200	---	$1\frac{1}{2}$	s
†13	37	79	250	---	1	s

* In this column, the letters indicate the following motions:

- b ran deeply - the model settled deeply into the water with little change in attitude
- d₂ dived slightly - the model stopped abruptly in a nose-down attitude with the nose of the model submerged
- o oscillated - the model oscillated about the longitudinal or vertical axis
- s skipped - the model rebounded from the water

† Recommended ditching attitude and flap setting.

Remarks: The landing speed was the most important variable affecting performance of this airplane. At high speeds, the highest deceleration and the most violent behaviors were encountered. A tail-down attitude (from 9° to 13°) is recommended.

TABLE 26

SUMMARY OF MODEL-DITCHING INVESTIGATION OF TRANSPORT A

[Model scale, 0.043; gross weight, 130,000 lb; center-of-gravity location, 26 percent M.A.C.; all values full scale]

Damage simulated by scale-strength parts (hatched area) and scale-strength nacelle struts.

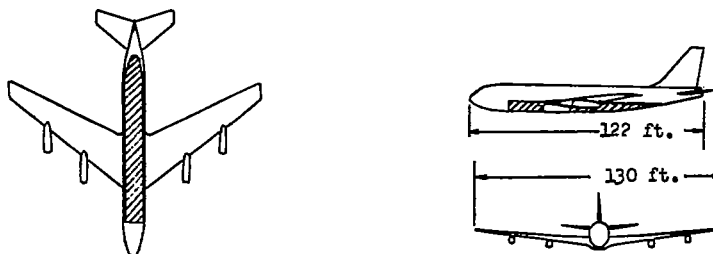

Landing attitude, deg	Flap setting, deg	Landing speed, knots	Length of run, ft	Maximum longitudinal deceleration, g units	Average longitudinal deceleration, g units	Motions of model (*)
Undamaged model with scale-strength nacelle struts						
6	0	146	1,100	2 1/2	1	s b
6	50	113	1,040	2 1/2	1 1/2	h
9	0	127	1,090	2 1/2	1 1/2	h
9	50	104	850	1 1/2	1 1/2	h
12	0	119	890	1 1/2	1 1/2	h
12	50	100	640	2	1 1/2	h
Damaged model with scale-strength nacelle struts						
6	0	146	700	6 1/2	1 1/2	b
6	50	113	450	6	1 1/2	h
9	0	127	500	5 1/2	1 1/2	h
9	50	104	420	5	1	h
12	0	119	480	6 1/2	1 1/2	h
†12	50	100	470	5	1	h

*In this column, the letters indicate the following motions:

- b ran deeply - the model settled deeply into the water with little change in attitude
- h ran smoothly - the model made a very stable run
- s skipped - the model rebounded from the water

†Recommended ditching attitude and flap setting.

Remarks: One or more of the nacelles were frequently torn off in a ditching but had little or no effect on behavior.

TABLE 27

SUMMARY OF MODEL-DITCHING INVESTIGATION OF TRANSPORT B

[Model scale, $\frac{1}{18}$; gross weight, 83,000 lb; center-of-gravity location, 25 percent M.A.C.; all values full scale]

(a) Without cargo container or hydro-ski.

Damage simulated by use of scale-strength parts (hatched areas) and removal of other parts (crosshatched areas).

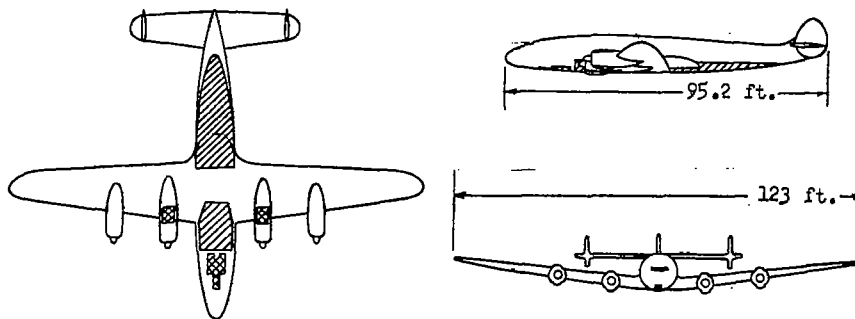

Landing attitude, deg	Flap setting, deg	Landing speed, knots	Length of run, ft	Maximum longitudinal deceleration, g units	Average longitudinal deceleration, g units	Motions of model (*)
Undamaged model						
4	0	148	900	6	1	s h
4	40	91	250	4	$1\frac{1}{2}$	d ₂
9	0	115	600	2	1	u h
9	40	79	400	4	$1\frac{1}{2}$	b
12	0	102	600	1	1	h
12	40	74	250	3	1	b
Damaged model						
4	40	91	200	4	2	b d ₂
†9	40	79	350	3	1	b d ₂
12	40	74	200	4	1	h b

*In this column, the letters indicate the following motions:

- b ran deeply - the model settled deeply into the water with little change in attitude
- d₂ dived slightly - the model stopped abruptly in a nose-down attitude with the nose of the model submerged
- h ran smoothly - the model made a very stable run
- s skipped - the model rebounded from the water
- u trimmed up - the attitude of the model increased while running in the water

† Recommended ditching attitude and flap setting.

Remarks: The fuselage will probably be damaged and leak substantially.

TABLE 27.- Continued

SUMMARY OF MODEL-DITCHING INVESTIGATION OF TRANSPORT B

[Gross weight of airplane plus cargo container, 93,000 lb;
all values full scale]

(b) With cargo container.

Model undamaged. Scale-strength cargo container (hatched area) attached as indicated.

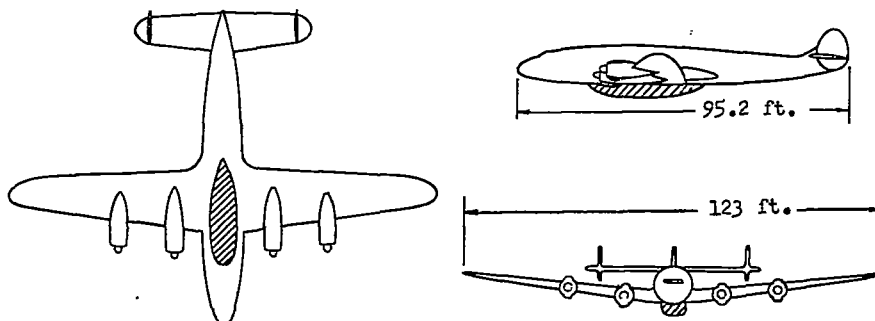

Landing attitude, deg	Flap setting, deg	Landing speed, knots	Length of run, ft	Maximum longitudinal deceleration, g units	Average longitudinal deceleration, g units	Motions of model (*)
4	40	95	650	--	$\frac{1}{2}$	h d ₂
†9	40	85	500	$1\frac{1}{2}$	$\frac{1}{2}$	h b
12	40	78	250	2	1	h b

* In this column, the letters indicate the following motions:

- b ran deeply - the model settled deeply into the water with little change in attitude
d₂ dived slightly - the model stopped abruptly in a nose-down attitude with the nose of the model submerged
h ran smoothly - the model made a very stable run

† Recommended ditching attitude and flap setting.

Remarks: The bottom of the cargo container was damaged considerably and evidently absorbed some of the landing loads. The decelerations were less and the behavior of the model was more favorable. The cargo container also protected the fuselage bottom.

TABLE 27.- Concluded

SUMMARY OF MODEL-DITCHING INVESTIGATION OF TRANSPORT B

(c) With hydro-ski.

No damage simulated. Ski as shown.

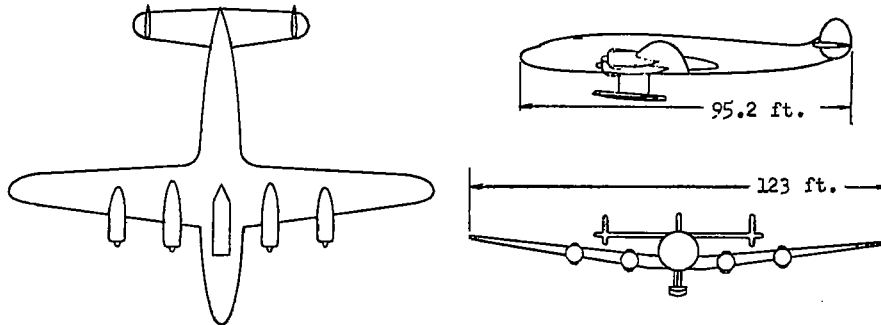

Landing attitude, deg	Flap setting, deg	Landing speed, knots	Length of run, ft	Maximum longitudinal deceleration, g units	Average longitudinal deceleration, g units	Motions of model (*)
4	40	91	1,220	$\frac{1}{2}$	$\frac{1}{2}$	h
9	40	79	720	- - -	$\frac{1}{2}$	h p

*In this column, the letters indicate the following motions:

- h ran smoothly - the model made a very stable run
- p porpoised - the model undulated about the transverse axis with some part of the model always in contact with the water

Remarks: The ditching behavior with the hydro-ski was very good. It is possible that critical damage can be eliminated from ditchings by using a hydro-ski ditching gear, thus greatly increasing the chances of survival and rescue.

TABLE 28

SUMMARY OF MODEL-DITCHING INVESTIGATION OF TRANSPORT C

[Model scale, $\frac{1}{15}$; gross weight, 43,500 lb; center-of-gravity location, 22 percent M.A.C.; all values full scale]

Damage simulated by use of scale-strength parts (hatched areas) and removal of other parts (crosshatched areas).

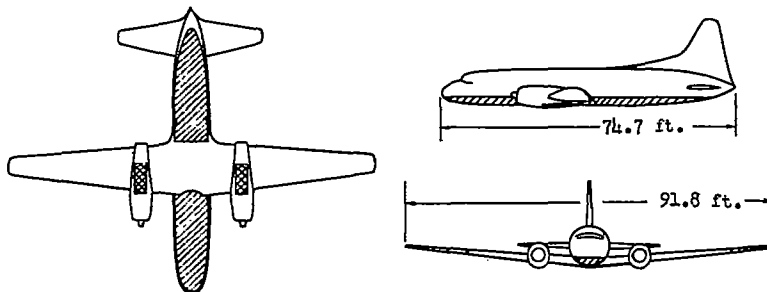

Landing attitude, deg	Flap setting, deg	Landing speed, knots	Length of run, ft	Maximum longitudinal deceleration, g units	Average longitudinal deceleration, g units	Motions of model (*)
Undamaged model						
1	0	164	850	4	$1\frac{1}{2}$	u h
1	39	100	350	5	$1\frac{1}{2}$	u h
5	0	122	650	3	1	u h
5	39	88	400	$1\frac{1}{2}$	1	h
9	0	105	600	$3\frac{1}{2}$	1	h
9	39	82	400	1	$\frac{1}{2}$	h
Damaged model						
5	0	122	250	8	$2\frac{1}{2}$	h b
5	39	88	300	$3\frac{1}{2}$	1	h
9	0	105	300	6	$1\frac{1}{2}$	h
†9	39	82	300	3	1	h

* In this column, the letters indicate the following motions:

- b ran deeply - the model settled deeply into the water with little change in attitude
- h ran smoothly - the model made a very stable run
- u trimmed up - the attitude of the model increased while running in the water

† Recommended ditching attitude and flap setting.

Remarks: The landing flaps were an important factor in the ditching behavior of this model. Failure of the scale-strength flaps was simulated by the flaps rotating up or being torn from the model. When the flaps rotated up, the model dived; but when the flaps were torn away, the model performed as indicated above.

TABLE 29

SUMMARY OF MODEL-DITCHING INVESTIGATION OF TRANSPORT D

[Model scale, $\frac{1}{15}$; gross weight, 50,000 lb; center-of-gravity location, 25 percent M.A.C.; all values full scale]

Damage simulated by removal of parts (crosshatched areas).

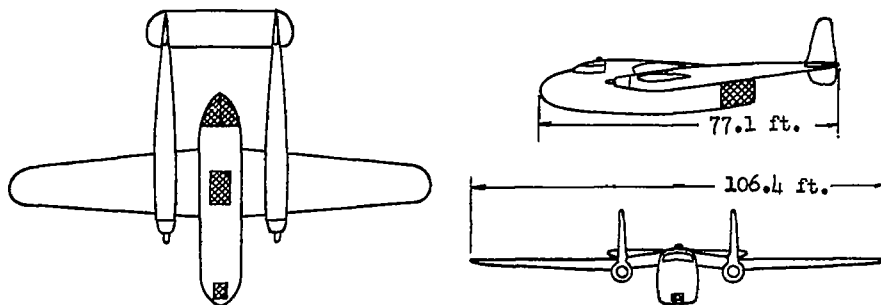

Landing attitude, deg	Flap setting, deg	Landing speed, knots	Length of run, ft	Maximum longitudinal deceleration, g units	Average longitudinal deceleration, g units	Motions of model (*)
Undamaged model						
2	40	109	700	1	1	u s p
7	40	90	300	2	1	u b
12	40	78	350	1	1	u b
Damaged model						
2	40	109	450	$2\frac{1}{2}$	1	u b
7	40	90	350	2	1	b
†12	40	78	300	1	1	b

*In this column, the letters indicate the following motions:

- b ran deeply - the model settled deeply into the water with little change in attitude
- p porpoised - the model undulated about the transverse axis with some part of the model always in contact with the water
- s skipped - the model rebounded from the water
- u trimmed up - the attitude of the model increased while running in the water

†Recommended ditching attitude and flap setting.

Remarks: The undamaged model trimmed up considerably when it contacted the water. Damage to the fuselage bottom greatly reduced the trimming up and caused the cargo compartment to flood rapidly, and thus to become a very hazardous ditching station.

TABLE 30

SUMMARY OF MODEL-DITCHING INVESTIGATION OF TRANSPORT E

[Model scale, $\frac{1}{14}$; gross weight, 44,000 lb; center-of-gravity location, 22 percent M.A.C.; all values full scale]

Damage simulated by scale-strength parts (hatched areas).

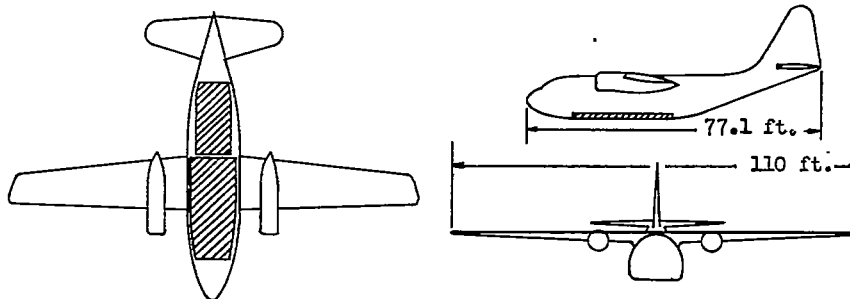

Landing attitude, deg	Flap setting, deg	Landing speed, knots	Length of run, ft	Maximum longitudinal deceleration, g units	Average longitudinal deceleration, g units	Motions of model (*)
Undamaged model						
4	45	80	385	--	$\frac{1}{2}$	u s
9	45	71	350	--	$\frac{1}{2}$	u h
14	45	65	350	--	$\frac{1}{2}$	u h
Damaged model						
4	45	80	450	2	$\frac{1}{2}$	s p
9	45	71	450	$1\frac{1}{2}$	$\frac{1}{2}$	h
†14	45	65	415	1	$\frac{1}{2}$	p

*In this column, the letters indicate the following motions:
 h ran smoothly - the model made a very stable run
 p porpoised - the model undulated about the transverse axis with some part of the model always in contact with the water
 s skipped - the model rebounded from the water
 u trimmed up - the attitude of the model increased while running in the water
 † Recommended ditching attitude and flap setting.

Remarks: The fuselage bottom will probably be damaged and the fuselage will fill with water and sink to the wing level.

TABLE 31

SUMMARY OF MODEL-DITCHING INVESTIGATION OF TRANSPORT F

[Model scale, $\frac{1}{24}$; gross weight, 175,000 lb; center-of-gravity location, 27 percent M.A.C.; all values full scale]

Damage simulated by use of scale-strength parts (hatched areas).

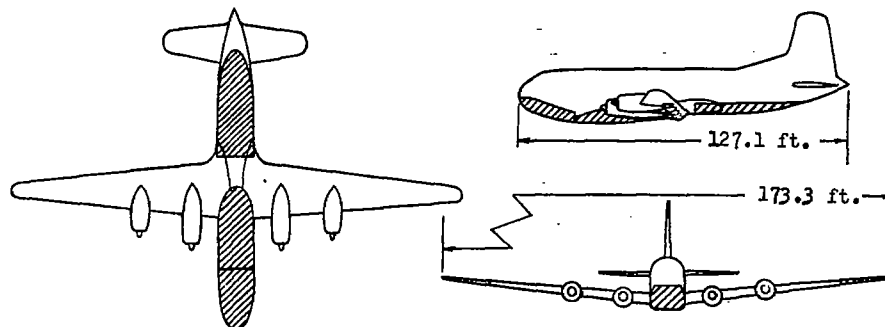

Landing attitude, deg	Flap setting, deg	Landing speed, knots	Length of run, ft	Maximum longitudinal deceleration, g units	Average longitudinal deceleration, g units	Motions of model (*)
Undamaged model						
2	40	109	750	2	$\frac{1}{2}$	u h
7	0	157	1,150	2	1	u h
7	40	96	800	1	$\frac{1}{2}$	u h
12	0	123	900	2	$\frac{1}{2}$	h
12	40	91	700	$2\frac{1}{2}$	$\frac{1}{2}$	h
Damaged model						
2	40	109	550	4	1	h
†7	40	96	500	$2\frac{1}{2}$	1	h
12	40	91	500	$4\frac{1}{2}$	1	p

*In this column, the letters indicate the following motions:

- h ran smoothly - the model made a very stable run
- p porpoised - the model undulated about the transverse axis with some part of the model always in contact with the water
- u trimmed up - the attitude of the model increased while running in the water

†Recommended ditching attitude and flap setting.

Remarks: The large clamshell doors in the nose of this airplane and the unusual shape of the fuselage bottom forward of the wing were of particular interest. With the scale-strength parts installed, only slight damage occurred to the clamshell doors and aft fuselage bottom, but considerable damage was sustained by the region just forward of the wing. However, the high location of the main floor should provide adequate ditching stations.

TABLE 32

SUMMARY OF MODEL-DITCHING INVESTIGATION OF TRANSPORT G

[Model scale, $\frac{1}{14}$; gross weight, 35,123 lb; center-of-gravity location, 31 percent M.A.C.; all values full scale]

Damage simulated by use of scale-strength parts (hatched areas) and removal of other parts (crosshatched areas).

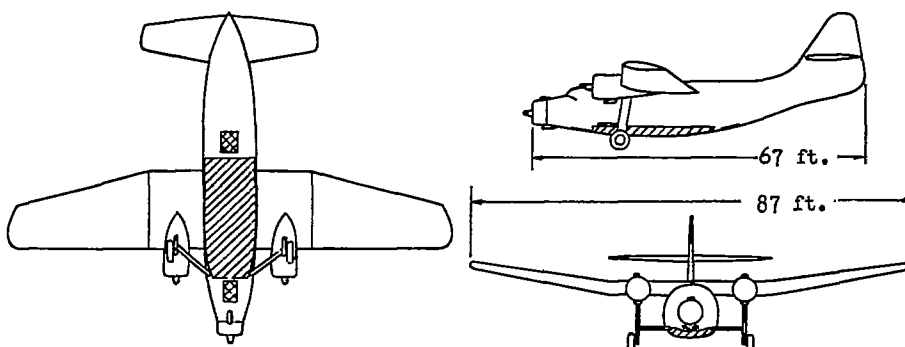

Landing attitude, deg	Flap setting, deg	Landing speed, knots	Length of run, ft	Maximum longitudinal deceleration, g units	Average longitudinal deceleration, g units	Motions of model (*)
Undamaged model						
0	55	64	150	$2\frac{1}{2}$	1	d ₁
4	0	102	200	5	$2\frac{1}{2}$	f
4	55	60	200	2	1	d ₂
8	0	87	150	4	2	d ₁
8	55	56	150	2	1	d ₂
Damaged model						
0	55	64	150	4	1	d ₁
4	55	60	150	2	1	d ₂
†8	55	56	150	2	1	d ₂

*In this column, the letters indicate the following motions:

- d₁ dived violently - the model stopped abruptly in a nose-down attitude with most of the model submerged
- d₂ dived slightly - the model stopped abruptly in a nose-down attitude with the nose of the model submerged
- f flipped over - the model rotated about the transverse axis and stopped in an inverted position

†Recommended ditching attitude and flap setting.

Remarks: The fixed landing gear on this model caused diving and flipping over. When the gear was removed the model either ran smoothly or skipped and porpoised.

TABLE 33

SUMMARY OF MODEL-DITCHING INVESTIGATION OF TRANSPORT B

[Model scale, $\frac{1}{25}$; gross weight, 255,000 lb; center-of-gravity location, 25 percent M.A.C.; all values full scale]

Damage simulated by use of scale-strength parts (hatched areas).

(a) Without hydroflap.

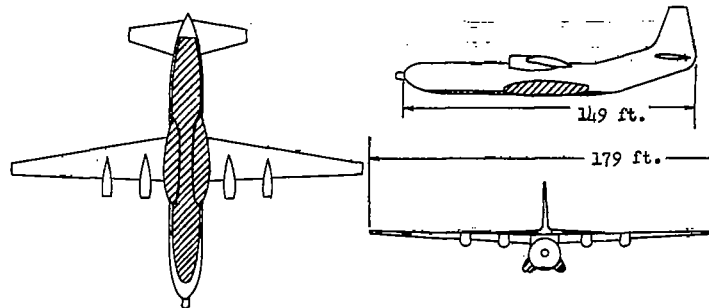

Landing attitude, deg	Flap setting, deg	Landing speed, knots	Length of run, ft	Maximum longitudinal deceleration, g units	Average longitudinal deceleration, g units	Motions of model (*)
Undamaged model						
1	45	120	1,270	2	$\frac{1}{2}$	u s h
5	0	155	1,400	$2\frac{1}{2}$	1	s o
5	45	110	690	$1\frac{1}{2}$	1	u h
10	0	137	1,490	$2\frac{1}{2}$	$\frac{1}{2}$	s
10	45	102	980	$1\frac{1}{2}$	$\frac{1}{2}$	u h
Damaged model						
1	45	120	570	2	1	b u h
5	0	155	810	5	$1\frac{1}{2}$	d ₂ u h
5	45	110	580	3	1	b u h
10	0	137	740	$5\frac{1}{2}$	1	d ₂ u h
†10	45	102	550	3	1	b u h

*In this column, the letters indicate the following motions:

- b ran deeply - the model settled deeply into the water with little change in attitude
- d₂ dived slightly - the model stopped abruptly in a nose-down attitude with the nose of the model submerged
- h ran smoothly - the model made a very stable run
- o oscillated - the model oscillated about the longitudinal or vertical axis
- s skipped - the model rebounded from the water
- u trimmed up - the attitude of the model increased while running in the water

† Recommended ditching attitude and flap setting.

Remarks: With scale-strength fuselage bottoms installed, the model had a tendency to dive during the first part of the ditching run, but recovered and ran smoothly. The landing-gear nacelles did not affect the ditching behavior. The fuselage is likely to flood rapidly and sink to the level of the wing.

TABLE 33.- Concluded

SUMMARY OF MODEL-DITCHING INVESTIGATION OF TRANSPORT H

(b) With hydroflap.

Damage same as shown in three-view sketch. Hydroflap as indicated.

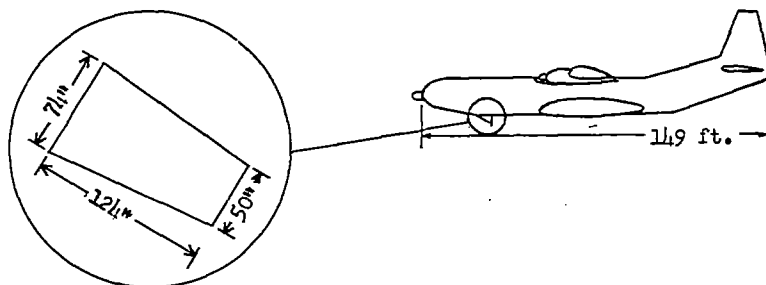

Landing attitude, deg	Flap setting, deg	Landing speed, knots	Length of run, ft	Maximum longitudinal deceleration, g units	Average longitudinal deceleration, g units	Motions of model (*)
5	45	110	690	2	1	h
† ₁₀	45	102	610	2½	1	p

* In this column, the letters indicate the following motions:
 h ran smoothly - the model made a very stable run
 p porpoised - the model undulated about the transverse axis with some part of the model always in contact with the water

† Recommended ditching attitude and flap setting.

Remarks: The hydroflap stopped the tendency to dive and decreased the amount of damage to the scale-strength sections.

TABLE 34

SUMMARY OF MODEL-DITCHING INVESTIGATION OF TRANSPORT I

[Model scale, $\frac{1}{16}$; gross weight, 72,000 lb; center-of-gravity location, 28 percent M.A.C.; all values full scale]

(a) Without hydro-skis.

Damage simulated by use of scale-strength parts (hatched areas) and removal of other parts (crosshatched areas).

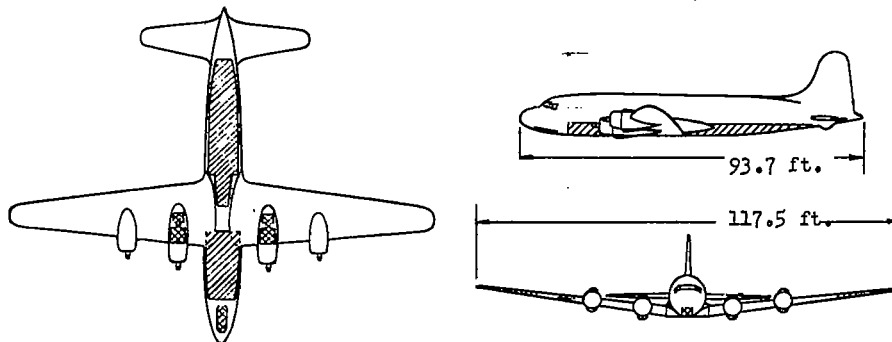

Landing attitude, deg	Flap setting, deg	Landing speed, knots	Length of run, ft	Maximum longitudinal deceleration, g units	Average longitudinal deceleration, g units	Motions of model (*)
Undamaged model						
2	50	98	650	2	$\frac{1}{2}$	h
7	50	87	600	1	$\frac{1}{2}$	h
12	50	79	450	$\frac{1}{2}$	$\frac{1}{2}$	h
Damaged model						
7	50	87	200	6	$\frac{1}{2}$	b
†12	50	79	250	$4\frac{1}{2}$	1	b

*In this column, the letters indicate the following motions:

b ran deeply - the model settled deeply into the water with little change in attitude

h ran smoothly - the model made a very stable run

†Recommended ditching attitude and flap setting.

Remarks: The damage sustained by the scale-strength sections was not severe in calm water ditchings.

TABLE 34.- Concluded

SUMMARY OF MODEL-DITCHING INVESTIGATION OF TRANSPORT I

(b) With hydro-skis.

No damage simulated. Hydro-skis as indicated.

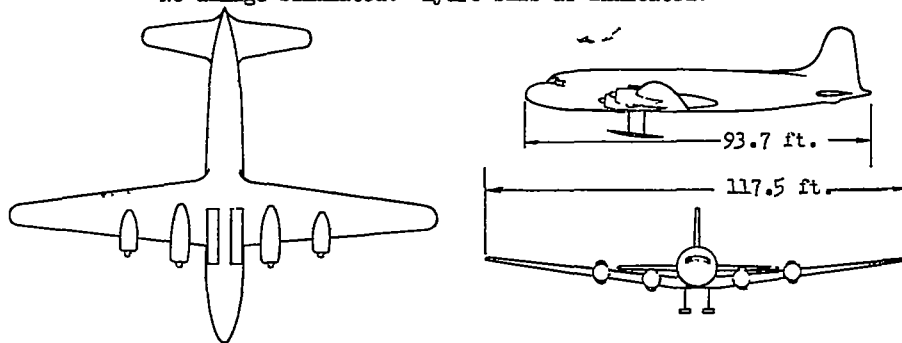

Landing attitude, deg	Flap setting, deg	Landing speed, knots	Length of run, ft	Maximum longitudinal deceleration, g units	Average longitudinal deceleration, g units	Motions of model (*)
2	50	95	1,300	---	$\frac{1}{2}$	h
7	50	88	750	---	$\frac{1}{2}$	h

* In this column, the letters indicate the following motions:
 h ran smoothly - the model made a very stable run

Remarks: The ditching behavior with the hydro-skis was very good. It is possible that critical damage can be eliminated from ditchings by using a hydro-ski ditching gear, and thus the chances of survival and rescue would be increased.

TABLE 35

SUMMARY OF MODEL-DITCHING INVESTIGATION OF TRANSPORT J

[Model scale, $\frac{1}{16}$; gross weight, 84,000 lb; center-of-gravity location, 28 percent M.A.C.; all values full scale]

Damage simulated by use of scale-strength parts (hatched areas) and removal of other parts (crosshatched areas).

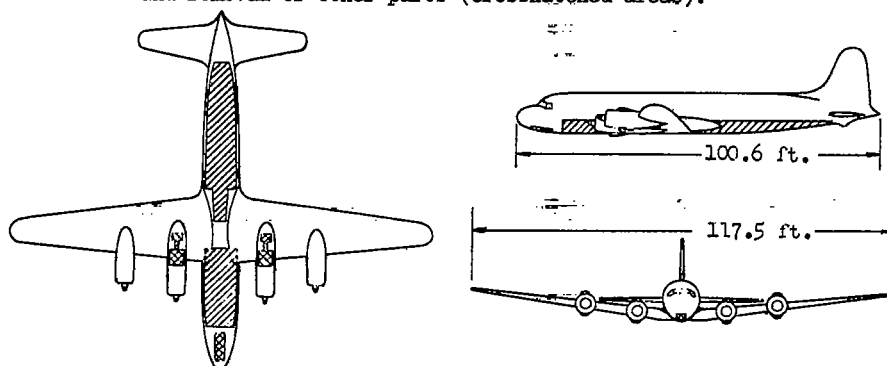

Landing attitude, deg	Flap setting, deg	Landing speed, knots	Length of run, ft	Maximum longitudinal deceleration, g units	Average longitudinal deceleration, g units	Motions of model (*)
Undamaged model						
2	50	106	700	3	$\frac{1}{2}$	h
7	50	94	600	1	$\frac{1}{2}$	h
12	0	109	550	2	1	h
12	50	85	450	$1\frac{1}{2}$	$\frac{1}{2}$	h
Damaged model						
7	50	94	250	5	$\frac{1}{2}$	b
[†] 12	50	85	250	$3\frac{1}{2}$	$\frac{1}{2}$	b

*In this column, the letters indicate the following motions:

b ran deeply - the model settled deeply into the water with little change in attitude

h ran smoothly - the model made a very stable run

[†]Recommended ditching attitude and flap setting.

Remarks: The damage sustained by the scale-strength sections was not severe in calm water ditchings.

TABLE 36

SUMMARY OF MODEL-DITCHING INVESTIGATION OF TRANSPORT K

[Model scale, $\frac{1}{24}$; gross weight, 160,000 lb; center-of-gravity location, 40 percent M.A.C.; all values full scale]

Damage simulated by use of scale-strength parts (hatched areas) and removal of other parts (crosshatched areas).

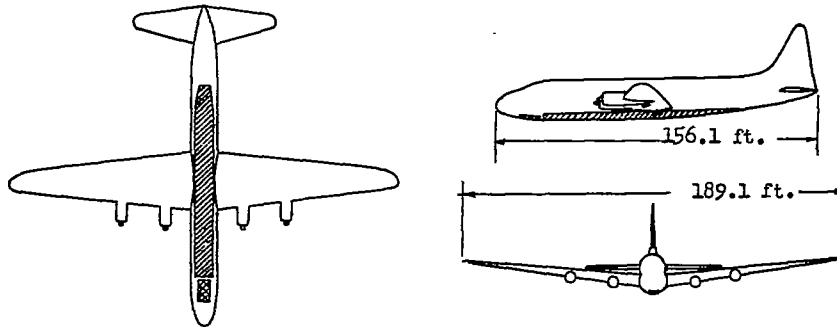

Landing attitude, deg	Flap setting, deg	Landing speed, knots	Length of run, ft	Maximum longitudinal deceleration, g units	Average longitudinal deceleration, g units	Motions of model (*)
Undamaged model						
1	45	90	450	1	1	u h
5	0	115	800	2	$\frac{1}{2}$	h
5	45	79	450	$\frac{1}{2}$	$\frac{1}{2}$	u h
9	0	96	600	1	$\frac{1}{2}$	h
9	45	72	450	1	$\frac{1}{2}$	h
Damaged model						
1	45	90	300	$2\frac{1}{2}$	1	b
†5	45	79	300	2	1	b h
9	45	72	300	2	1	b

*In this column, the letters indicate the following motions:

- b ran deeply - the model settled deeply into the water with little change in attitude
- h ran smoothly - the model made a very stable run
- u trimmed up - the attitude of the model increased while running in the water

†Recommended ditching attitude and flap setting.

Remarks: The scale-strength sections did not sustain severe damage. Most damage usually occurred near the part of the fuselage that contacted the water first. It is likely that the cargo floor will not fail and that the interior of the airplane will be relatively safe in a ditching.

TABLE 37

SUMMARY OF MODEL-DITCHING INVESTIGATION OF TRANSPORT L

[Model scale, $\frac{1}{20}$; gross weight, 130,000 lb; center-of-gravity location, 25 percent M.A.C.; all values full scale]

Damage simulated by use of scale-strength parts (hatched areas) and removal of other parts (crosshatched areas).

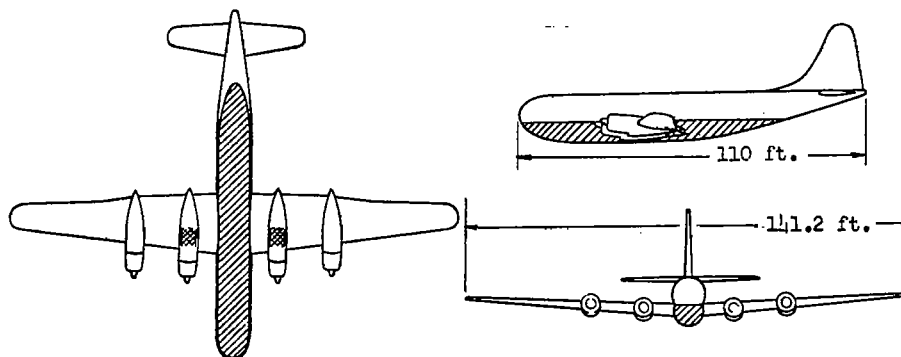

Landing attitude, deg	Flap setting, deg	Landing speed, knots	Length of run, ft	Maximum longitudinal deceleration, g units	Average longitudinal deceleration, g units	Motions of model (*)
Undamaged model						
3	45	109	650	2	1	u h
6	45	102	500	2	1	u h
9	0	129	800	3	1	u p
9	45	97	450	2	1	u o h
Damaged model						
3	45	109	400	3	$\frac{1}{2}$	h
†6	45	102	400	4	1	p h
9	45	97	350	4	1	b h

*In this column, the letters indicate the following motions:

- b ran deeply - the model settled deeply into the water with little change in attitude
- h ran smoothly - the model made a very stable run
- o oscillated - the model oscillated about the longitudinal or vertical axis
- p porpoised - the model undulated about the transverse axis with some part of the model always in contact with the water
- u trimmed up - the attitude of the model increased while running in the water

†Recommended ditching attitude and flap setting.

Remarks: The scale-strength sections sustained damage. The lower compartment of this airplane will probably fill with water. However, the strong cargo floor should provide protection for the upper deck and the low wing should provide enough buoyancy to give personnel time to escape.