

NACA TN 3902

NATIONAL ADVISORY COMMITTEE FOR AERONAUTICS

TECHNICAL NOTE 3902

RESULTS OF TWO FREE-FALL EXPERIMENTS ON FLUTTER OF THIN
UNSWEPT WINGS IN THE TRANSONIC SPEED RANGE

By William T. Lauten, Jr., and Herbert C. Nelson

Langley Aeronautical Laboratory
Langley Field, Va.

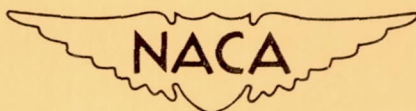

Washington

January 1957

NATIONAL ADVISORY COMMITTEE FOR AERONAUTICS

TECHNICAL NOTE 3902

RESULTS OF TWO FREE-FALL EXPERIMENTS ON FLUTTER OF THIN
UNSWEPT WINGS IN THE TRANSONIC SPEED RANGE¹

By William T. Lauten, Jr., and Herbert C. Nelson

SUMMARY

Flutter data in the transonic speed range for four nearly identical, thin, unswept wings have been obtained by the bomb-drop method. Two wings fluttered at a Mach number of 0.85, one wing fluttered at a Mach number of 1.03, and the other wing fluttered at a Mach number of 1.07.

The experimental flutter speeds were compared with values calculated by using a method of analysis which includes the effect of mode shape and is based on two-dimensional flow. The calculations were made for Mach numbers ranging from 0 to 1.43, including a Mach number of 1.0. The experimental flutter speeds, in general, exceeded the calculated values. There is an indication that the critical flutter region is moved to a higher Mach number range when thin wings are used.

INTRODUCTION

A knowledge of the flutter phenomena in the transonic region is of great importance to the designer of high-speed aircraft. At present, however, neither are there sufficient experimental data nor is there adequate theory to enable the designer to predict transonic flutter characteristics quantitatively.

In order to meet the need for such data, a transonic-flutter investigation has been conducted by the National Advisory Committee for Aeronautics. A series of tests has been made on wings attached to freely falling bodies (flutter bombs) or to rocket-propelled missiles, and the results of these tests are reported in references 1 to 3. The wings utilized in the bomb tests were, with one exception, 9 percent thick.

In order to extend the investigation of transonic-flutter phenomena to thin wings, two more flutter bombs were dropped, each carrying a pair of unswept, untapered wings 4 percent thick at the root and 2 percent

¹Supersedes recently declassified NACA Research Memorandum L51C08 by William T. Lauten, Jr., and Herbert C. Nelson, 1951.

thick at the tip. The four wings were made as nearly identical as practical. In order to obtain flutter data at different Mach numbers but at nearly the same conditions of density and temperature, the two bombs were dropped from different altitudes. One was dropped from 35,000 feet in an effort to obtain flutter at a Mach number slightly greater than one. The other was dropped from a lower altitude, 22,000 feet, so that the dynamic pressure would be sufficient to cause flutter at a Mach number slightly less than one.

The primary purpose of this paper is to present results obtained from the drop tests of these two flutter bombs. Comparison is also made of the experimental results and a series of calculations at different Mach numbers based on two-dimensional, unsteady compressible-flow theory. The Mach numbers for which calculations were made ranged from 0 to 1.43 and included 1.0.

SYMBOLS

A	aspect ratio (including body intercept)
a	nondimensional wing-elastic-axis position measured from midchord, positive rearward $(2x_0 - 1)$
a + x_α	nondimensional wing center of gravity measured from midchord, positive rearward $(2x_1 - 1)$
b	semichord of test wing, feet
F	mode shape $\left(\frac{\text{Displacement of any spanwise section}}{\text{Displacement of tip}} \right)$
f	frequency, cycles per second
g	structural damping coefficient
h	geometric altitude (distance above sea level), feet
I_α	polar moment of inertia about elastic axis, $\frac{\text{foot-pound-second}^2}{\text{feet}}$
κ	ratio of air density to wing mass $\left(\frac{\pi \rho b^2}{m} \right)$
l	length of wing, feet
M	Mach number

m	mass of wing per unit length, slugs per foot
ω	circular frequency, radians per second ($2\pi f$)
P	static pressure, pounds per square foot
q	dynamic pressure, pounds per square foot
ρ	air density, slugs per cubic foot
T	free-air temperature, degrees Fahrenheit absolute
t	time after release of bomb from airplane, seconds
V	velocity, feet per second
x_0	distance of elastic axis of wing section behind leading edge, fraction of chord
x_1	distance of center of gravity of wing section behind leading edge, fraction of chord

Subscripts:

e	experimental values obtained at start of flutter
c	calculated values based on two-dimensional compressible-flow theory; $c = R$ for $M = 0$
R	calculated values based on two-dimensional incompressible-flow theory; R is special case of c as noted previously
h_1	first bending
h_2	second bending
α_1	first torsion

APPARATUS AND METHODS

Two identical bombs, designated the FB-7 and FB-8, were utilized to carry the four wings. The wings of the FB-7 were designated 7001 and 7002, and of the FB-8, 8001 and 8002. A photograph and a schematic drawing of the bombs are shown in figures 1 and 2. The four wings were

made as nearly identical as possible, were unswept, and had a length-to-chord ratio of 3. They were constructed of solid aluminum alloy with a root section 4 percent thick (NACA 65A004) and a tip section 2 percent thick (NACA 65A002). The wing parameters are listed in tables I and II.

Instrumentation

Each of the four wings was equipped with bending and torsion strain gages mounted near the root, and with a breakwire which indicates wing failure. Each bomb carried a longitudinal accelerometer for the purpose of determining velocity. The FB-7 carried a normal accelerometer and the FB-8 carried a rate-of-roll indicator. The latter two instruments were used in an effort to determine the normal and rotational motions of the bomb body. The accelerometers and the rate-of-roll indicator were mounted as close to the center of gravity of the bomb as space considerations would permit. Signals from the strain gages, accelerometers, and breakwires were transmitted over six telemeter channels simultaneously to two receiving stations. Time of release, altitude, and speed of the airplane were recorded or determined as reported in reference 2.

Measurements

In addition to telemetered data, measurements similar to those reported in reference 1 were taken of wing parameters. Atmospheric and flight conditions at time of flutter are listed in table III and are plotted against time in figures 3 and 4.

Test Procedure

The FB-8 was dropped from 35,000 feet in an effort to get the wings through the low-transonic speed range at a density low enough to delay flutter until a Mach number greater than 1.0 was reached. The FB-7 was dropped from a lower altitude, 22,000 feet, so that the dynamic pressure, at about the same air density as the density at flutter of the FB-8 wings, would be sufficient to cause flutter in the low-transonic range. Thus flutter would be obtained over a limited range of Mach numbers with nearly identical wings and with approximately the same test medium density. It would therefore be possible to define more accurately a flutter curve for the transonic region.

Reduction of Data

The reduction of principal data is similar to that reported in reference 1. Flutter was indicated when the oscillations from the bending and torsion gages increased rapidly in amplitude and were of the same frequency. An example is given in figure 5 where a portion of a typical flutter record is presented. Associated conditions during flutter were determined from the time-history curves shown in figures 3 and 4.

RESULTS AND DISCUSSION

The time histories of the falls of the two flutter bombs are shown in figures 3 and 4. In these figures the variation of the bomb altitude, velocity, and Mach number with time are plotted, together with the free-air static pressure and temperature corresponding to the geometric altitude of the bomb.

The wings mounted on the FB-7 fluttered at nearly the same instant at a Mach number of 0.85 and the telemeter record indicated that it was a bending-torsion type of flutter. The experimental data at flutter are listed in detail in table III.

In the test of the FB-8, flutter was also obtained on both wings but not simultaneously. Wing 8002 started to flutter at a Mach number of 1.03 and wing 8001 started to flutter at a Mach number of 1.07. The telemeter record indicated that this flutter also was a bending-torsion type. The experimental data at flutter are listed in detail in table III.

Generally flutter is a rapidly diverging phenomenon and the wings usually fail after a few oscillations. In the present tests, when flutter commenced, the amplitude built up and remained almost constant for the remainder of the test. None of the wings failed although all fluttered for a period of at least 11 seconds.

It is felt necessary to emphasize the fact that during fall and at the flutter condition the wings were flying at, or very near, zero angle of attack. Two other attempts to test similar wings resulted in structural failures before the bomb was released from the airplane. These failures were attributed to the fact that the wings were being carried at approximately 5° angle of attack. This angle of attack apparently caused a type of torsional instability that occurred at a much lower velocity than that attained in the successful tests.

The normal accelerometer in the FB-7 showed a maximum normal acceleration of $\pm 0.44g$ during flutter. This acceleration at the flutter frequency, which by this time had increased from 32.2 to 43.2 cycles per second, is equivalent to a translation of the bomb body of about ± 0.002 inch. The rate-of-roll indicator in the FB-8 showed a maximum rate of roll of 155° per second during flutter. These small values of translation and roll show that during flutter the wings are attached to an essentially rigid body.

In order that the experimental results reported herein may be readily compared with results of previous transonic flutter tests, the value of the ratio V_e/V_R was determined, where V_e is the experimental flutter speed and V_R is the reference flutter speed. Both the experimental and reference flutter speeds for the wings reported herein are listed in table III. The reference flutter speeds are determined from calculations which are based on two-dimensional incompressible-flow theory and which involve a method of flutter analysis that includes the effect of mode shape (reference 4).

The values of the ratio V_e/V_R for the wings tested are plotted against Mach number in figure 6. In order that the data reported herein may be compared with preceding tests, an experimental flutter curve taken from a similar plot (figure 6 of reference 3) is also plotted in figure 6. For ease of reference, figure 6 of reference 3 is presented as figure 7 of this paper. It may be noted that the values for wings 8001 and 8002 fall somewhat below the curve taken from reference 3 despite the fact that these wings are nearly similar, except for thickness, to those reported in that reference. Therefore, the difference may be attributed to thickness effect. From figure 6 there is the indication that for thin wings the critical flutter region, defined in reference 3 as the region around $M = 0.9$, may be moved to a higher Mach number range.

In addition to the reference velocity V_R , other flutter velocities were obtained from calculations using the same method of analysis but involving unsteady compressible-flow coefficients for Mach numbers of 0.7 and 0.8 (reference 5), 1.0 (reference 6), and 1.11, 1.25, and 1.43 (reference 7). The results of all calculations, using the air density associated with flutter, are shown in table IV. In order to present a satisfactory comparison of the calculated and experimental results, all values are reduced to a common density $\rho = 0.00156$. This reduction is accomplished by using this density in the calculation for all the wings and by multiplying experimental values by the square root of the proper density ratio. In figure 8 these results are shown as nondimensional flutter-speed coefficient $V/b\omega_{\alpha_1}$ plotted against Mach number. Since the wings were so nearly alike, only one curve of average values is used to represent the four. The portion of this curve between $M = 0.8$

and 1.1 is plotted as a dashed line to indicate an arbitrary fairing. It is of interest to note that, in this particular case, the calculation at a Mach number of 1.0 compares very favorably with the experimental trend. In other cases, the agreement might possibly be less favorable. The calculated values as obtained from a faired curve of these calculations are exceeded by the experimental values.

Flutter frequencies were also obtained from the calculations. In figure 9 a comparison is made between experimental and calculated frequencies in the form of a plot of ω/ω_{α_1} against Mach number. Since the calculated results obtained are nearly the same for all four wings, average values of the calculations are used and the experimental points are superposed. The calculated values are based on an air density of 0.00156. It is of interest to note that the calculated frequencies compare favorably with the experimental frequencies when the air-force coefficients for Mach numbers in the range of the tests are used, in particular, for Mach numbers of 0.8 and 1.0.

CONCLUDING REMARKS

Flutter data have been obtained in the transonic speed range by dropping two freely falling bodies each of which carried two wings. The four wings were nearly identical, were unswept and untapered, and varied in thickness from 4 percent at the root to 2 percent at the tip. Two wings fluttered at a Mach number of 0.85, one wing fluttered at a Mach number of 1.03, and the other wing fluttered at a Mach number of 1.07.

For comparison with the experimental results, flutter speeds were calculated by using a method of analysis which includes the effect of mode shape and is based on two-dimensional flow. The calculations were made for Mach numbers ranging from 0 to 1.43, including 1.0. A graphical comparison of the experimental flutter speeds with a faired curve of the calculated values showed that the experimental flutter speeds exceeded those calculated. There was an indication that the critical flutter region was moved to a higher Mach number range when thin wings were used.

Flutter frequencies as well as flutter speeds were obtained from the calculations. The calculated frequencies compared favorably with the

experimental frequencies when the air-force coefficients for Mach numbers in the range of the tests were used, in particular, for Mach numbers of 0.8 and 1.0.

Langley Aeronautical Laboratory,
National Advisory Committee for Aeronautics,
Langley Field, Va., March 14, 1951.

REFERENCES

1. Barmby, J. G., and Clevenson, S. A.: Initial Test in the Transonic Range of Four Flutter Airfoils Attached to a Freely Falling Body. NACA RM L7B27, 1947.
2. Clevenson, S. A., and Lauten, William T., Jr.: Flutter Investigation in the Transonic Range of Six Airfoils Attached to Three Freely Falling Bodies. NACA RM L7KL7, 1948.
3. Lauten, William T., Jr., and Barmby, J. G.: Continuation of Wing Flutter Investigation in the Transonic Range and Presentation of a Limited Summary of Flutter Data. NACA RM L9B25b, 1949.
4. Smilg, Benjamin, and Wasserman, Lee S.: Application of Three-Dimensional Flutter Theory to Aircraft Structures. ACTR No. 4798, Materiel Div., Army Air Corps, July 9, 1942.
5. Dietze, F., Frazer, Robert Alexander, and Schade, Th.: Tables and Curves of Two-Dimensional Sub-Sonic Aerodynamic Derivatives. Rep. No. Structures D.5/7501/I.T.M./5, British R.A.E., 1950.
6. Nelson, Herbert C., and Berman, Julian H.: Calculations on the Forces and Moments for an Oscillating Wing-Aileron Combination in Two-Dimensional Potential Flow at Sonic Speed. NACA Rep. 1128, 1953. (Supersedes NACA TN 2590.)
7. Garrick, I. E., and Rubinow, S. I.: Flutter and Oscillating Air-Force Calculations for an Airfoil in a Two-Dimensional Supersonic Flow. NACA Rep. 846, 1946. (Supersedes NACA TN 1158.)

TABLE I.- CONSTANT WING PARAMETERS

Parameter	Wing			
	7001	7002	8001	8002
b	0.333	0.333	0.333	0.333
l	2	2	2	2
A	7.3	7.3	7.3	7.3
x ₁	0.446	0.446	0.446	0.446
x ₀	0.438	0.438	0.414	0.438
a	-0.125	-0.125	-0.172	-0.125
a + x _α	-0.108	-0.108	-0.108	-0.108
f _{h₁}	17	16.5	17.25	17.5
f _{h₂}	75	75.5	83.5	78.75
f _{α₁}	101.5	101	105.75	103.5
g _{h₁}	0.004	0.004	0.004	0.004
g _{α₁}	0.001	0.001	0.001	0.001

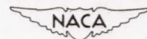

TABLE II.- SPANWISE VARIATION OF WING PARAMETERS^a

Percent span	m	I_{α}	F_{h_1}	F_{α_1}
0	-----	-----	0	0
16.67	0.060	0.0014	.039	.095
33.33	.054	.0013	.160	.238
50.00	.049	.0012	.324	.422
66.67	.043	.0010	.515	.637
83.33	.038	.0009	.763	.882
100.00	.032	.0008	1.000	1.000

^aApplies to all wings.

TABLE III.- EXPERIMENTAL FLUTTER DATA

Parameter	Wing			
	7001	7002	8001	8002
M	0.852	0.852	1.07	1.03
V_e	933	933	1170	1108
f_e	32.2	32.2	33.8	31.3
ρ_e	0.001665	0.001665	0.00156	0.001408
q	725	725	1067	864
l/k at 0.71 ^a	72.6	72.6	77.5	85.8
t	25.8	25.8	37	33.8
h	11,300	11,300	13,400	16,750
T	499.5	499.5	495	483.2
p	1425	1425	1323	1165
V_R	871	863	952	973
f_R	47.4	46.7	49.7	48.1

^aBased on air density at flutter.

TABLE IV.- FLUTTER PARAMETERS CALCULATED AT VARIOUS MACH NUMBERS
 USING APPROPRIATE ρ AND EXPERIMENTAL RESULTS

Wing	Theory														Experiment		
	$M_c = 0$		$M_c = \frac{7}{10}$		$M_c = \frac{8}{10}$		$M_c = 1.0$		$M_c = \frac{10}{9}$		$M_c = \frac{10}{8}$		$M_c = \frac{10}{7}$				
	$\frac{V_R}{b\omega_{\alpha_1}}$	$\frac{\omega_R}{\omega_{\alpha_1}}$	$\frac{V_c}{b\omega_{\alpha_1}}$	$\frac{\omega_c}{\omega_{\alpha_1}}$	$\frac{V_c}{b\omega_{\alpha_1}}$	$\frac{\omega_c}{\omega_{\alpha_1}}$	$\frac{V_c}{b\omega_{\alpha_1}}$	$\frac{\omega_c}{\omega_{\alpha_1}}$	$\frac{V_c}{b\omega_{\alpha_1}}$	$\frac{\omega_c}{\omega_{\alpha_1}}$	$\frac{V_c}{b\omega_{\alpha_1}}$	$\frac{\omega_c}{\omega_{\alpha_1}}$	$\frac{V_c}{b\omega_{\alpha_1}}$	$\frac{\omega_c}{\omega_{\alpha_1}}$	M	$\frac{V_e}{b\omega_{\alpha_1}}$	$\frac{\omega_e}{\omega_{\alpha_1}}$
7001	4.11	0.465	3.85	0.356	3.74	0.341	4.7	0.301	4.17	0.778	3.70	0.986	∞	---	0.85	4.39	0.316
7002	4.08	.463	3.86	.345	3.75	.339	4.7	.299	4.14	.774	3.70	.984	∞	---	.85	4.41	.318
8001	4.30	.470	3.96	.352	3.80	.336	4.7	.272	4.21	.815	3.73	.989	∞	---	1.07	5.29	.319
8002	4.48	.463	4.17	.355	3.98	.338	4.95	.296	4.45	.806	3.72	.984	∞	---	1.03	5.12	.302



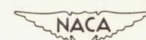
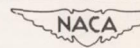
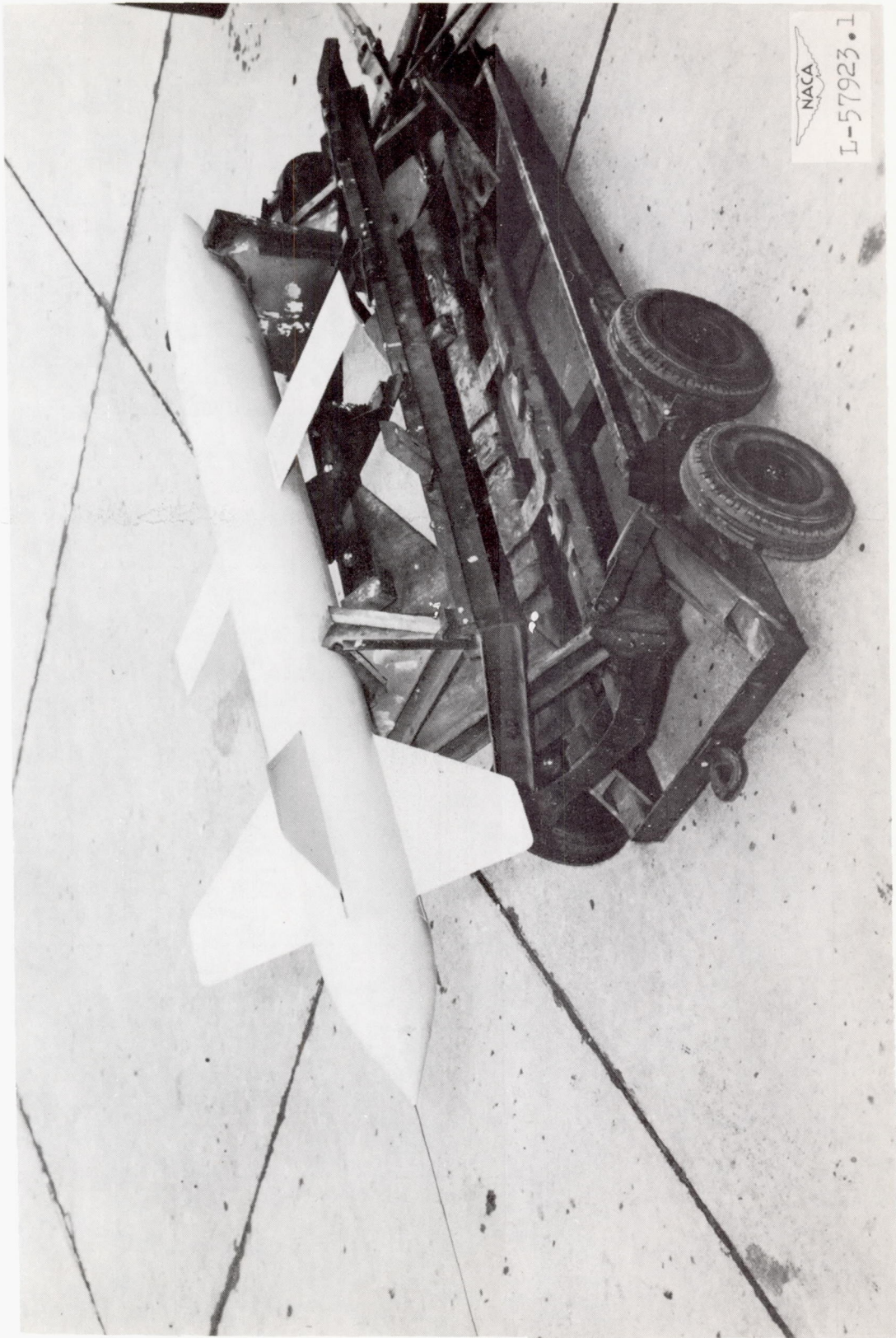
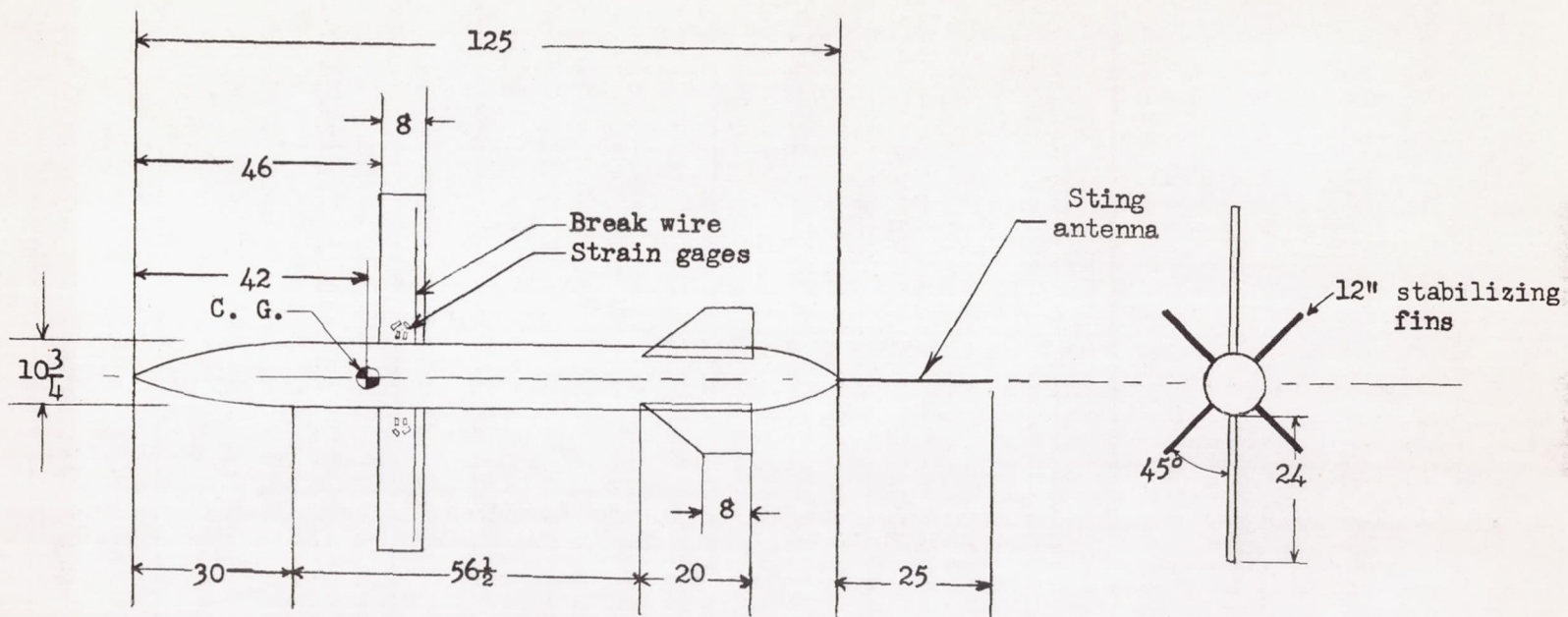

Figure 1.- Photograph of the flutter bomb.



(All dimensions in inches)

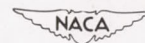

Figure 2.- Dimensional drawing of the FB-7 and FB-8.

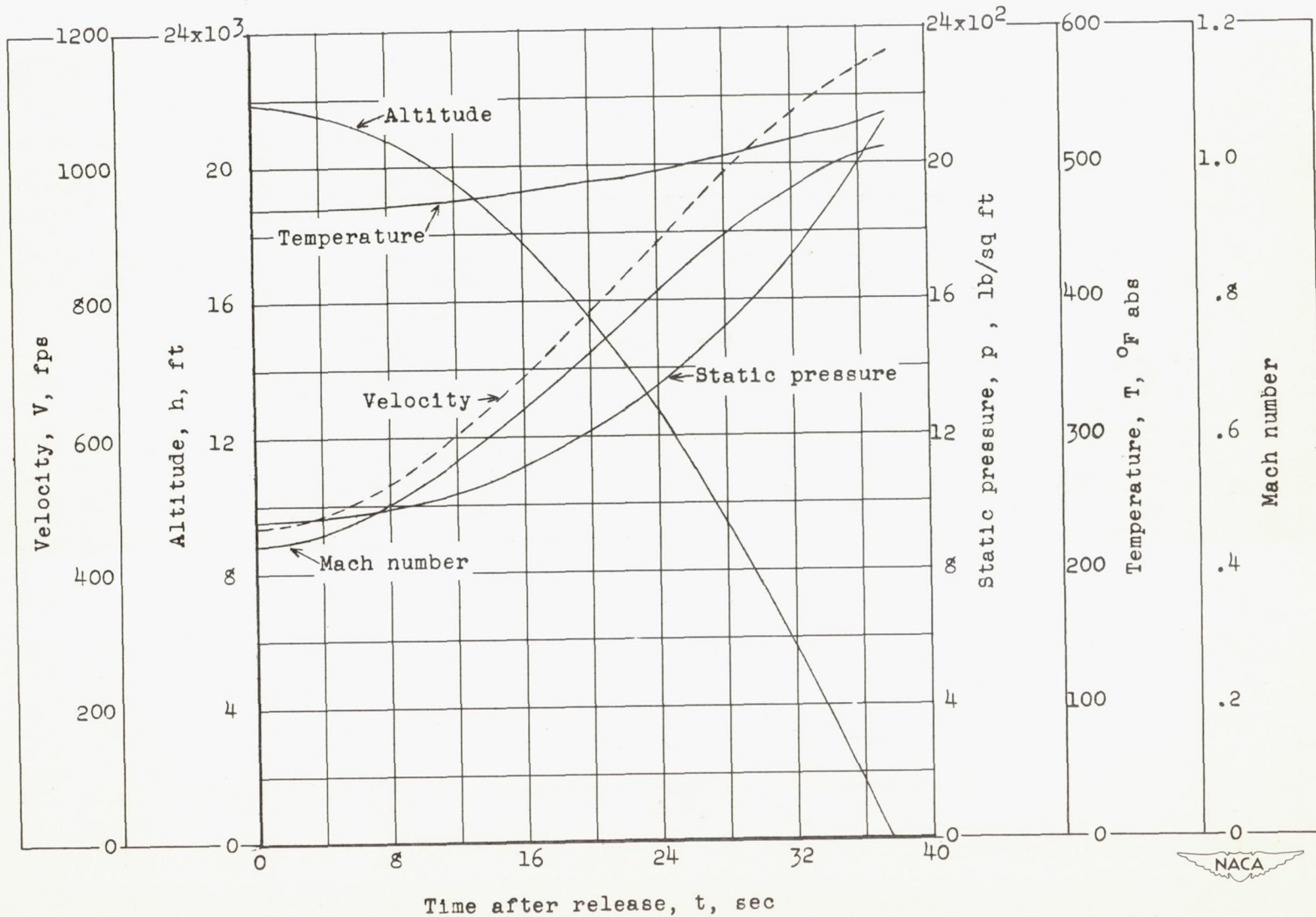

Figure 3.- Time history of fall of the FB-7.



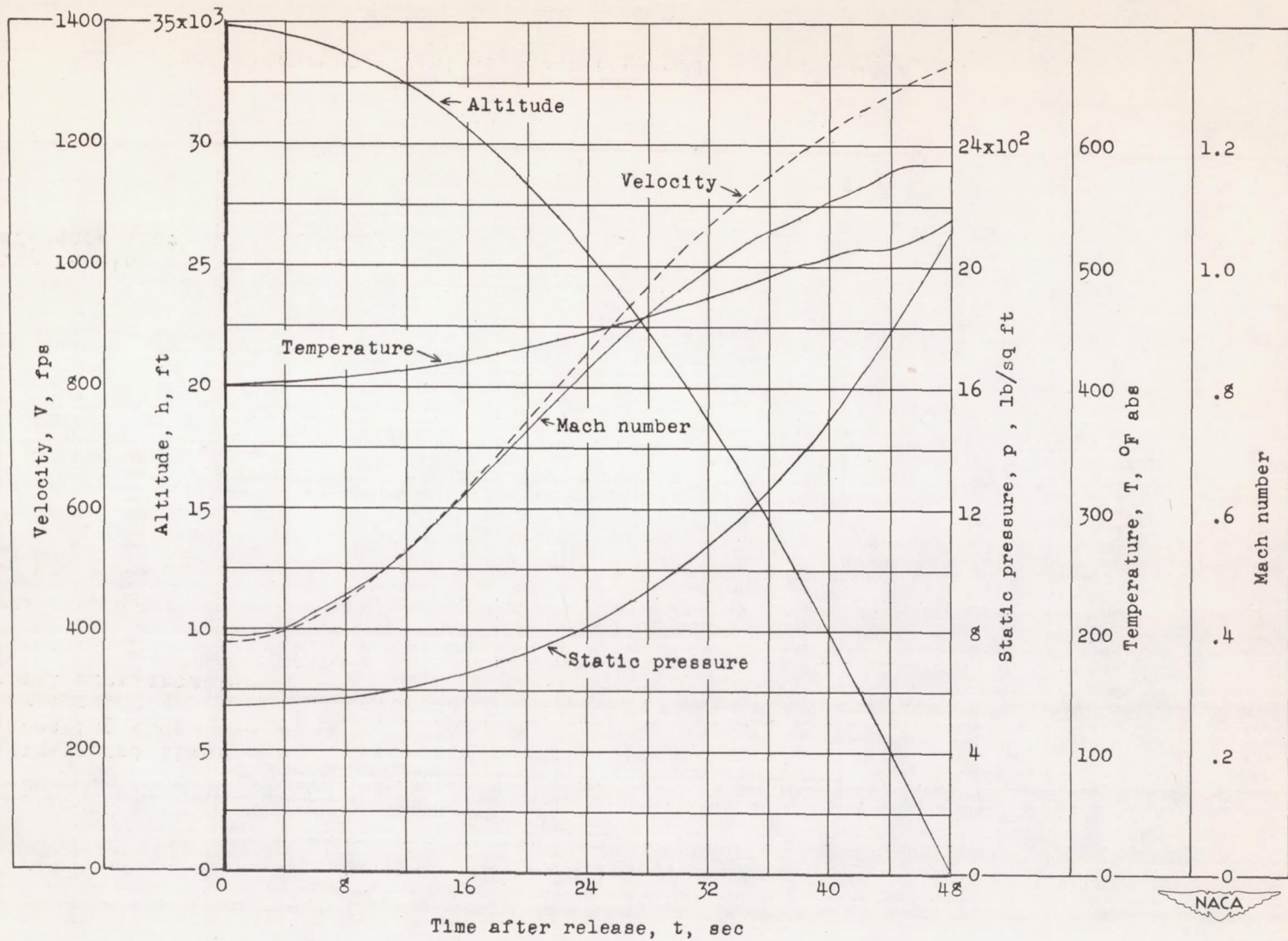

Figure 4.- Time history of fall of the FB-8.

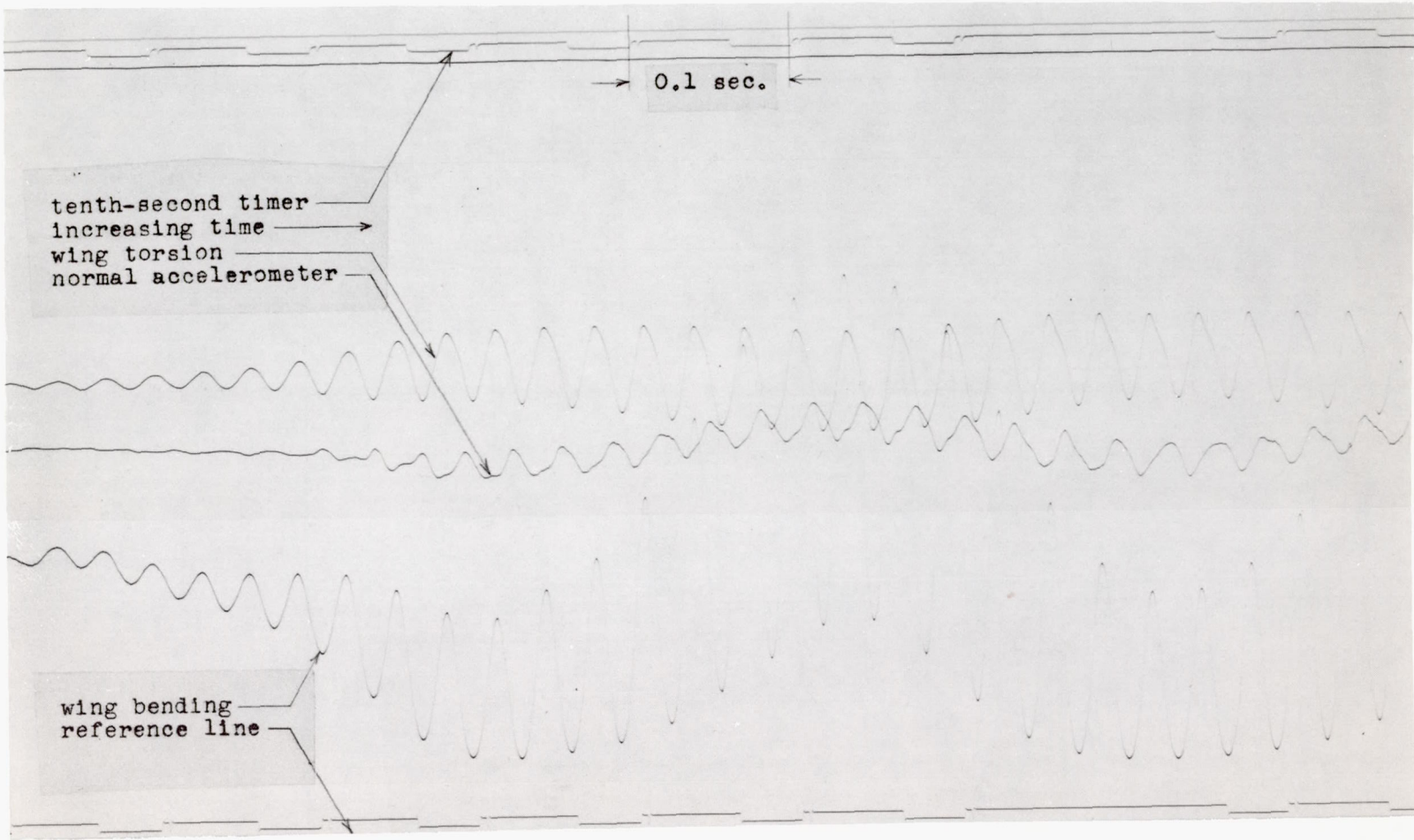

Figure 5.- Typical flutter record.



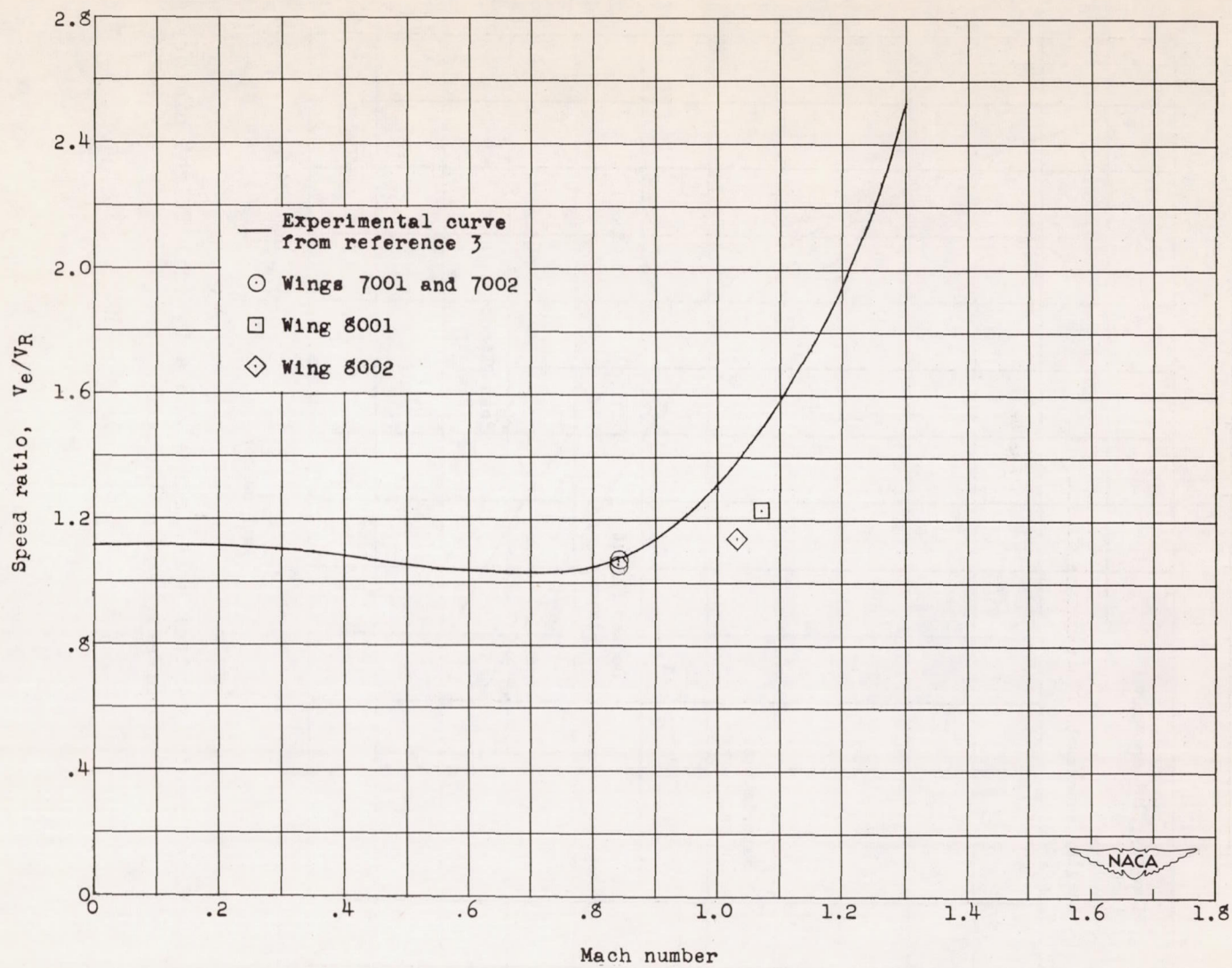
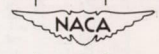

Figure 6.- Variation of V_e/V_R as a function of Mach number.



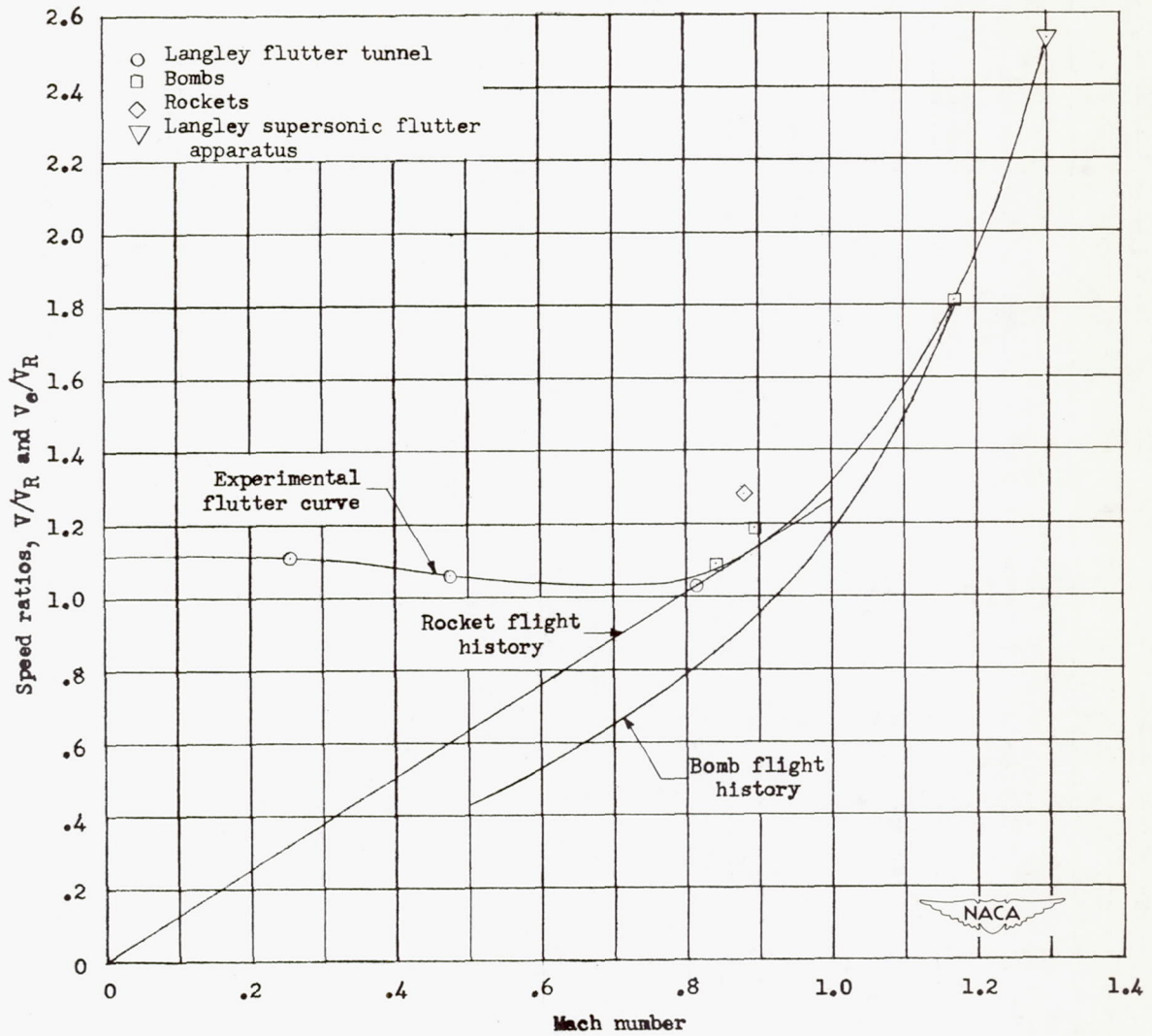

Figure 7.- Experimental flutter speed curve and a typical flight history of a rocket and a bomb.

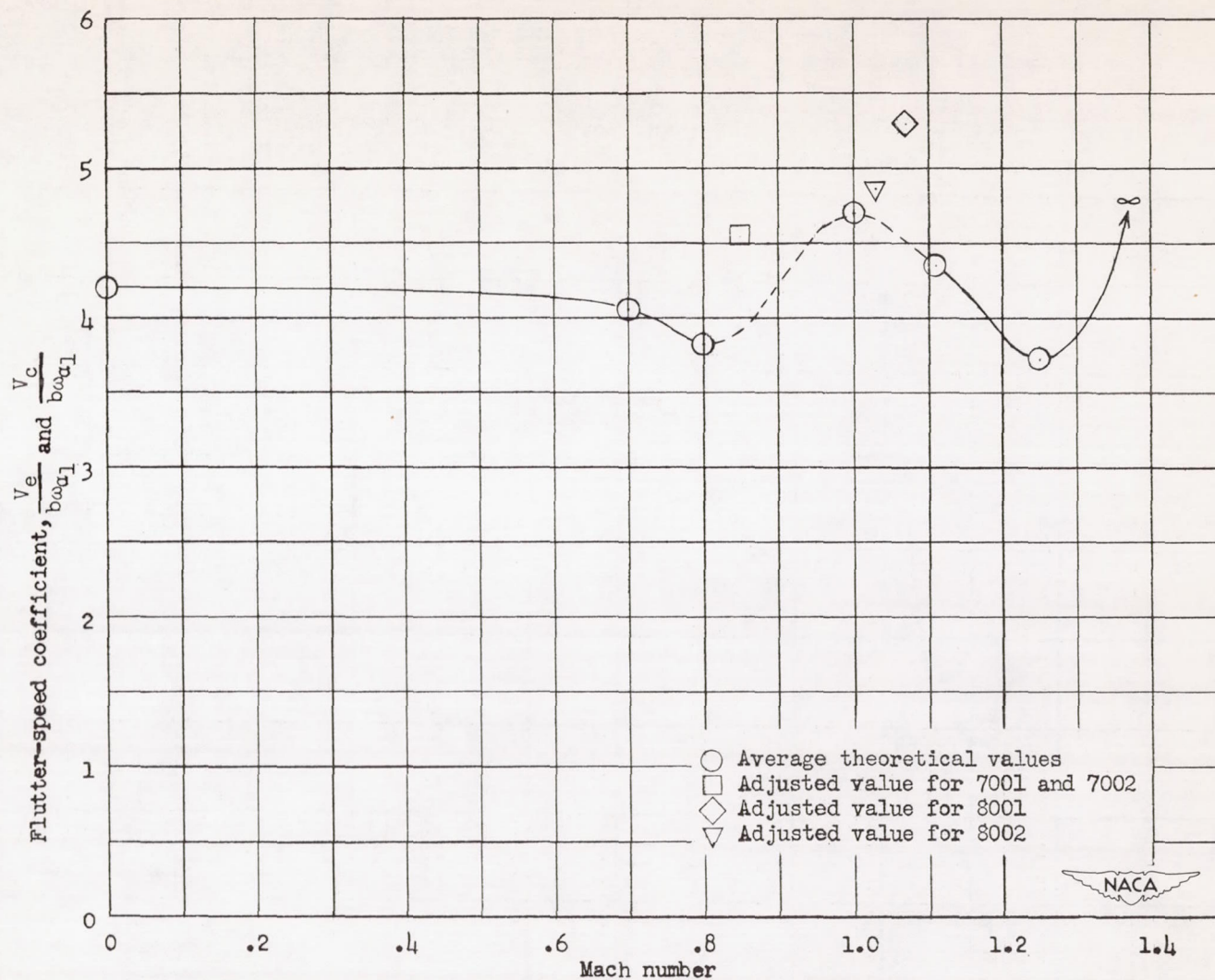

Figure 8.- Variation of flutter-speed coefficient as a function of Mach number (all points referred to $\rho = 0.00156$).

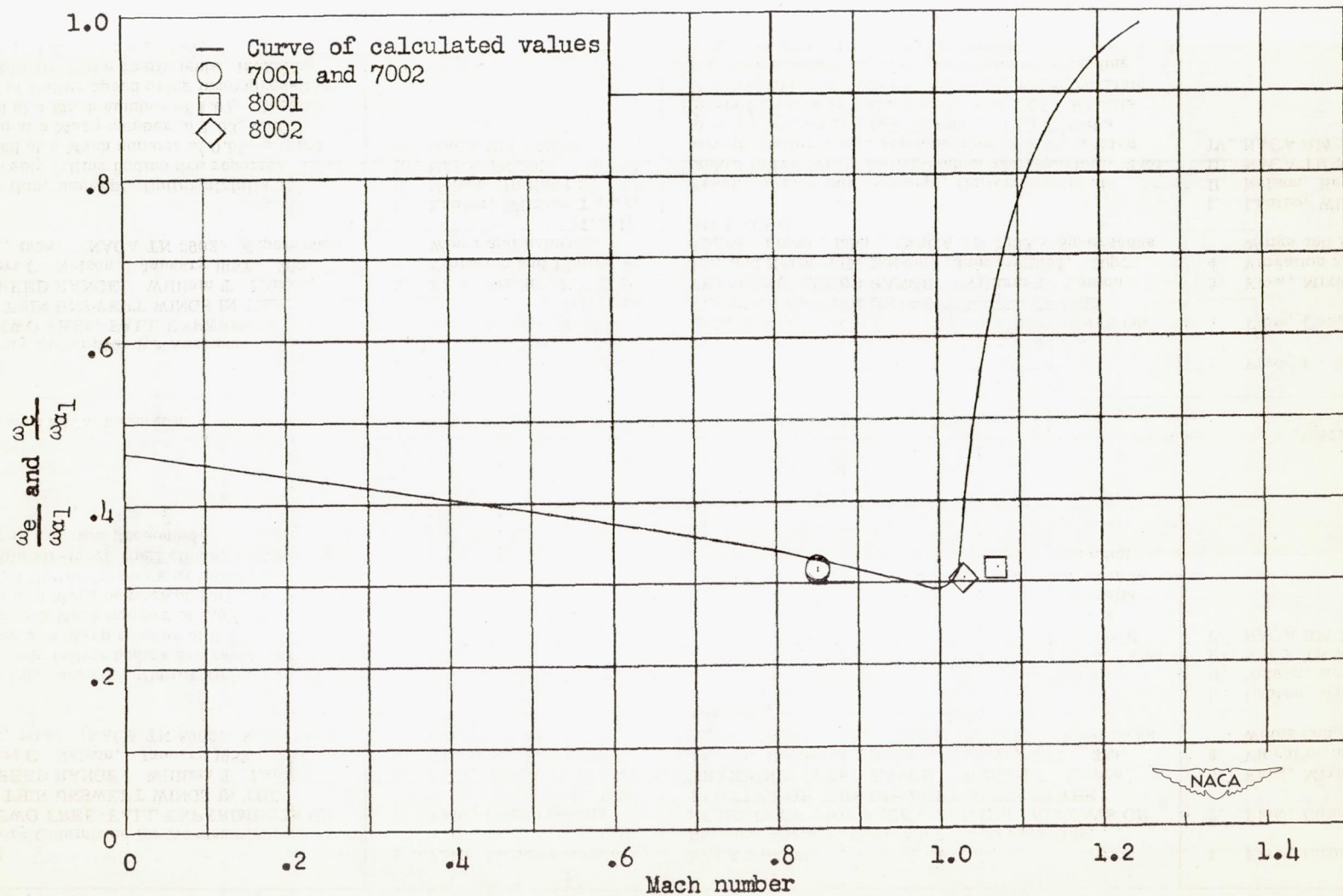

Figure 9.- Ratio of flutter frequency to torsional frequency as a function of Mach number.