

**CLASSIFICATION CANCELLED**

**DECLASSIFIED**

TECHNICAL NOTES

NATIONAL ADVISORY COMMITTEE FOR AERONAUTICS

No. 847

SQUARE PLATE WITH CLAMPED EDGES UNDER NORMAL PRESSURE  
PRODUCING LARGE DEFLECTIONS

By Samuel Levy  
National Bureau of Standards

**CLASSIFIED DOCUMENT**

This document contains classified information affecting the National Defense of the United States within the meaning of the Espionage Act, USC 50:31 and 32. Its transmission or the revelation of its contents in any manner to an unauthorized person is prohibited by law. Information so classified may be imparted only to persons in the military and naval Services of the United States, appropriate civilian officers and employees of the Federal Government who have a legitimate interest therein, and to United States citizens of known loyalty and discretion who of necessity must be informed thereof.

Washington  
May 1942

**FILE COPY**  
To be returned to  
the files of the Langley  
Memorial Aeronautical  
Laboratory.

**FOR REFERENCE**

NOT TO BE TAKEN FROM THIS ROOM

NATIONAL ADVISORY COMMITTEE FOR AERONAUTICS

TECHNICAL NOTE NO. 847

SQUARE PLATE WITH CLAMPED EDGES UNDER NORMAL PRESSURE  
PRODUCING LARGE DEFLECTIONS

By Samuel Levy

SUMMARY

A theoretical analysis is given for the stresses and deflections of a square plate with clamped edges under normal pressure producing large deflections. Values of the bending stress and membrane stress at the center of the plate and at the midpoint of the edge are given for center deflections up to 1.9 times the plate thickness. The shape of the deflected surface is given for low pressures and for the highest pressure considered. Convergence of the solution is considered, and it is estimated that the possible error is less than 2 percent. The results are compared with the only previous approximate analysis known to the author and agree within 5 percent. They are also shown to compare favorably with the known exact solutions for the long rectangular plate and the circular plate.

INTRODUCTION

An exact solution for the small deflections of a plate with clamped edges was given by Hencky in reference 2 and an approximate solution for large deflections was presented by Way in reference 3. In a previous paper (reference 1) there is presented a solution of the fundamental Von Kármán large-deflection equations for a simply supported rectangular plate under combined edge compression and lateral loading.

In the present paper a theoretical analysis is given for the stresses and deflections of a square plate under normal pressure producing large deflections. The edge supports are assumed to clamp the plate rigidly against rotations and displacements normal to the edge but permit displacements parallel to the edge. The analysis replaces the edge bending moments by an equivalent pressure distribution and then applies the general solution for the

simply supported rectangular plate. The results for small deflections obtained by the analysis agree exactly with those of Hencky and for large deflections differ by less than 5 percent from the approximate solution of Way.

The work was carried on with the financial assistance of the National Advisory Committee for Aeronautics. Acknowledgment is made to the Bureau of Aeronautics, Navy Department, for its cooperation in a program of tests of rectangular plates under normal pressure that furnished the background for the preparation of this paper. The author is grateful for the assistance of members of the Engineering Mechanics Section of the National Bureau of Standards, particularly that of Dr. W. Ramberg and Mr. S. Greenman.

## FUNDAMENTAL EQUATIONS

### Symbols

Consider an initially flat square plate of uniform thickness (fig. 1), and let

- a length of sides
- h thickness
- p normal pressure, assumed uniform
- w normal displacement of points of middle surface
- E Young's modulus
- $\mu$  Poisson's ratio
- D  $\frac{Eh^3}{12(1-\mu^2)}$  flexural rigidity of plate
- x, y coordinate axes lying along edges of plate with their origin at one corner
- $m_x, m_y$  edge bending moments per unit length about x and y axes, respectively
- $\sigma$  normal stress
- $\tau$  shearing stress

- $\epsilon$             tensile strain, unit elongation
- $\gamma$             shearing strain
- $\sigma_x, \sigma_y$     extreme-fiber stresses in directions of axes
- $\sigma'_x, \sigma'_y$     median-fiber stresses in directions of axes
- $\sigma''_x, \sigma''_y$     extreme-fiber bending stresses in directions of axes
- $w_{m,n}$         deflection coefficients
- $F$             stress function
- $b_{m,n}$         stress coefficients
- $\bar{\sigma}_x, \bar{\sigma}_y$     average median-fiber stresses in  $x$  and  $y$  directions, respectively
- $p_a(x,y)$     auxiliary pressure replacing edge moments
- $p_b(x,y)$     uniform normal pressure  $p$  expressed as a Fourier series
- $p_c(x,y) = p_a(x,y) + p_b(x,y)$
- $P_{r,s}$         coefficient in Fourier series for pressure,  $p_c(x,y)$
- $c$             moment arm of auxiliary pressure distribution,  $p_a(x,y)$
- $k_r, k_s$       moment coefficients

Expressions for Stresses and Strains

The general equations for stresses and strains are developed by Timoshenko in reference 4 (ch. IX) and are also given in reference 1. The stresses at the middle surface of the plate are related to the stress function  $F$  by:

$$\left. \begin{aligned} \sigma'_x &= \frac{\partial^2 F}{\partial y^2} \\ \sigma'_y &= \frac{\partial^2 F}{\partial x^2} \\ \tau'_{xy} &= -\frac{\partial^2 F}{\partial x \partial y} \end{aligned} \right\} \quad (1)$$

the extreme-fiber bending stresses in the plate are related to the deflections by

$$\left. \begin{aligned} \sigma_x'' &= -\frac{Eh}{2(1-\mu^2)} \left( \frac{\partial^2 w}{\partial x^2} + \mu \frac{\partial^2 w}{\partial y^2} \right) \\ \sigma_y'' &= -\frac{Eh}{2(1-\mu^2)} \left( \frac{\partial^2 w}{\partial y^2} + \mu \frac{\partial^2 w}{\partial x^2} \right) \\ \tau_{xy}'' &= -\frac{Eh}{(1+\mu)} \left( \frac{\partial^2 w}{\partial x \partial y} \right) \end{aligned} \right\} \quad (2)$$

and the extreme-fiber bending stresses at the edges of the plate are related to the bending moments per unit length by:

$$\left. \begin{aligned} \sigma_x'' &= \frac{6m_y}{h^2} \\ \sigma_y'' &= \mu \frac{6m_y}{h^2} \end{aligned} \right\} \quad (x=0, x=a) \\ \left. \begin{aligned} \sigma_x'' &= \mu \frac{6m_x}{h^2} \\ \sigma_y'' &= \frac{6m_x}{h^2} \end{aligned} \right\} \quad (y=0, y=a) \quad (3)$$

The strains at the middle surface of the plate are:

$$\left. \begin{aligned} \epsilon_x' &= \frac{1}{E}(\sigma_x' - \mu\sigma_y') = \frac{1}{E} \left( \frac{\partial^2 F}{\partial y^2} - \mu \frac{\partial^2 F}{\partial x^2} \right) \\ \epsilon_y' &= \frac{1}{E}(\sigma_y' - \mu\sigma_x') = \frac{1}{E} \left( \frac{\partial^2 F}{\partial x^2} - \mu \frac{\partial^2 F}{\partial y^2} \right) \\ \gamma_{x,y}' &= \frac{2(1+\mu)}{E} \tau_{xy}' = -\frac{2(1+\mu)}{E} \frac{\partial^2 F}{\partial x \partial y} \end{aligned} \right\} \quad (4)$$

## Relations between Edge Moments and Lateral Pressure

The required edge moments  $m_x$ ,  $m_y$  will be replaced by an auxiliary pressure distribution  $p_a(x, y)$  near the edges of the plate as shown in figure 2. If this pressure distribution is expressed by a Fourier series (reference 5, p. 295) and the value of  $c$  approaches zero, the auxiliary pressure is

$$p_a(x, y) = \sum_{r=1, 3, 5, \dots}^{\infty} \frac{4\pi m_y r}{a^2} \sin \frac{r\pi x}{a} + \sum_{s=1, 3, 5, \dots}^{\infty} \frac{4\pi m_x s}{a^2} \sin \frac{s\pi y}{a} \quad (5)$$

Express  $m_x$  and  $m_y$  by a Fourier series, where  $k_s$  and  $k_r$  are coefficients to be determined and where for a square plate  $k_s = k_r$  when  $s = r$ ,

$$\left. \begin{aligned} m_x &= \frac{4a^2}{\pi^3} p \sum_{r=1, 3, 5, \dots}^{\infty} k_r \sin \frac{r\pi x}{a} \\ m_y &= \frac{4a^2}{\pi^3} p \sum_{s=1, 3, 5, \dots}^{\infty} k_s \sin \frac{s\pi y}{a} \end{aligned} \right\} \quad (6)$$

Inserting equation (6) in equation (5) gives

$$p_a(x, y) = \left(\frac{4}{\pi}\right)^2 p \sum_{r=1, 3, 5, \dots}^{\infty} \sum_{s=1, 3, 5, \dots}^{\infty} (rk_s + sk_r) \sin \frac{r\pi x}{a} \sin \frac{s\pi y}{a} \quad (7)$$

The uniform normal pressure  $p$  may also be expressed by a Fourier series (reference 5, p. 295) as,

$$p_b(x, y) = \left(\frac{4}{\pi}\right)^2 p \sum_{r=1, 3, 5, \dots}^{\infty} \sum_{s=1, 3, 5, \dots}^{\infty} \left(\frac{1}{rs}\right) \sin \frac{r\pi x}{a} \sin \frac{s\pi y}{a} \quad (8)$$

The addition of the uniform normal pressure  $p_b(x, y)$  and the auxiliary pressure replacing the edge moments  $p_a(x, y)$  is obtained by adding equations (7) and (8) and gives

$$p_c(x, y) = \left(\frac{4}{\pi}\right)^2 p \sum_{r=1}^{\infty} \sum_{s=1}^{\infty} \left(\frac{1}{rs} + rk_s + sk_r\right) \sin \frac{r\pi x}{a} \sin \frac{s\pi y}{a} \quad (9)$$

where

$$P_{r,s} = \left(\frac{4}{\pi}\right)^2 p \left( \frac{1}{rs} + rk_s + sk_r \right) \quad (10)$$

Relation between Stress Function  $F$ , Deflection  $w$ ,  
and Pressure Coefficients  $P_{r,s}$

Since the edge moments  $m_x$  and  $m_y$  have been replaced by the auxiliary pressure distribution  $p_a(x,y)$  (equation (7)), the general solution for the simply supported rectangular plate given in reference 1 may be applied. This solution was derived in terms of Fourier series from the Von Kármán equations (reference 6). The form of Von Kármán's equations used is that given on page 343 of reference 4.

$$\frac{\partial^4 F}{\partial x^4} + 2 \frac{\partial^4 F}{\partial x^2 \partial y^2} + \frac{\partial^4 F}{\partial y^4} = E \left[ \left( \frac{\partial^2 w}{\partial x \partial y} \right)^2 - \frac{\partial^2 w}{\partial x^2} \frac{\partial^2 w}{\partial y^2} \right]$$

$$\frac{\partial^4 w}{\partial x^4} + 2 \frac{\partial^4 w}{\partial x^2 \partial y^2} + \frac{\partial^4 w}{\partial y^4} = \frac{p}{D} + \frac{h}{D} \left( \frac{\partial^2 F}{\partial y^2} \frac{\partial^2 w}{\partial x^2} + \frac{\partial^2 F}{\partial x^2} \frac{\partial^2 w}{\partial y^2} - 2 \frac{\partial^2 F}{\partial x \partial y} \frac{\partial^2 w}{\partial x \partial y} \right) \quad (11)$$

For the square plate the general solution describes the deflection by the Fourier series,

$$w = \sum_{m=1,3,5,\dots}^{\infty} \sum_{n=1,3,5,\dots}^{\infty} w_{m,n} \sin \frac{m\pi x}{a} \sin \frac{n\pi y}{a} \quad (12)$$

the pressure by the Fourier series previously given in equation (9),

$$p_c(x,y) = \sum_{r=1,3,5,\dots}^{\infty} \sum_{s=1,3,5,\dots}^{\infty} P_{r,s} \sin \frac{r\pi x}{a} \sin \frac{s\pi y}{a} \quad (13)$$

and the stress function  $F$  by the Fourier series and polynomials,

$$F = \frac{\bar{\sigma}_y x^2}{2} + \frac{\bar{\sigma}_{xy} y^2}{2} + \sum_{m=0,2,4,\dots}^{\infty} \sum_{n=0,2,4,\dots}^{\infty} b_{m,n} \cos \frac{m\pi x}{a} \cos \frac{n\pi y}{a} \quad (14)$$

and shows that for zero displacement normal to the edges of the plate,

$$\left. \begin{aligned} \bar{\sigma}_x - \nu \bar{\sigma}_y &= \frac{E\pi^2}{8a^2} \sum_{m=1,3,5,\dots}^{\infty} \sum_{n=1,3,5,\dots}^{\infty} m^2 w_{m,n}^2 \\ \text{and} \\ \bar{\sigma}_y - \nu \bar{\sigma}_x &= \frac{E\pi^2}{8a^2} \sum_{m=1,3,5,\dots}^{\infty} \sum_{n=1,3,5,\dots}^{\infty} n^2 w_{m,n}^2 \end{aligned} \right\} (15)$$

The general solution (reference 1) gives general equations from which the membrane stress function coefficients  $b_{m,n}$  can be calculated in terms of the deflection function coefficients  $w_{m,n}$ . For the special case where  $a = b$  (square plate), in the present papers the first 23 of these coefficients  $b_{m,n}$  are,

$$\left. \begin{aligned} b_{0,2} = b_{2,0} &= \frac{E}{32} (w_{1,1}^2 + 9w_{1,3}^2 + 2w_{1,1}w_{1,3} - 18w_{1,3}w_{3,3} + 25w_{1,5}^2 - 2w_{1,3}w_{1,5} \dots) \\ b_{0,4} = b_{4,0} &= \frac{E}{64} (w_{1,1}w_{1,3} + 9w_{1,3}w_{3,3} - w_{1,1}w_{1,5} \dots) \\ b_{2,2} &= \frac{E}{8} (w_{1,1}w_{1,3} - 2w_{1,3}^2 + 4w_{1,3}w_{1,5} - 9w_{3,3}w_{1,5} \dots) \\ b_{0,6} = b_{6,0} &= \frac{E}{288} (w_{1,3}^2 + 9w_{3,3}^2 + 2w_{1,1}w_{1,5} \dots) \\ b_{2,4} = b_{4,2} &= \frac{E}{400} (-w_{1,1}w_{1,3} + 25w_{1,3}^2 + 9w_{1,1}w_{3,3} + 9w_{1,1}w_{1,5} - 49w_{1,3}w_{1,5} + 81w_{3,3}w_{1,5} \dots) \\ b_{0,8} = b_{8,0} &= \frac{E}{256} (w_{1,3}w_{1,5} \dots) \\ b_{2,6} = b_{6,2} &= \frac{E}{400} (-w_{1,1}w_{1,5} + 9w_{1,3}w_{3,3} + 16w_{1,3}w_{1,5} \dots) \\ b_{4,4} &= \frac{E}{64} (-w_{1,3}^2 + 8w_{1,3}w_{1,5} - 9w_{1,5}^2 \dots) \\ b_{0,10} = b_{10,0} &= \frac{E}{800} (w_{1,5}^2 \dots) \\ b_{2,8} = b_{8,2} &= \frac{E}{4624} (-w_{1,3}w_{1,5} + 81w_{3,3}w_{1,5} \dots) \\ b_{4,6} = b_{6,4} &= \frac{E}{2704} (-9w_{1,3}w_{3,3} - 49w_{1,3}w_{1,5} + 169w_{1,5}^2 \dots) \\ b_{4,8} = b_{8,4} &= \frac{E}{1600} (-9w_{3,3}w_{1,5} \dots) \\ b_{6,6} &= \frac{E}{36} (-w_{1,5}^2 \dots) \end{aligned} \right\} (16)$$



The family of equations relating the pressure coefficients  $p_{r,s}$  and the deflection coefficients  $w_{m,n}$  are also given by the general solution (reference 1). For the special case  $a = b$  (square plate), presented in this paper, the first 22 terms in each of these equations are given in table 1 for Poisson's ratio  $\mu = 0.316$ . Advantage has been taken of the relation  $w_{m,n} = w_{n,m}$ , which holds for a square plate under symmetrical loads, to reduce the size of table 1 as well as equations (16). As an example of the use of table 1, the first few terms of the first equation (giving the relation between  $p_{1,1}$  and the  $w_{m,n}$ 's) are given in equation (17).

$$0 = -\frac{p_{1,1}a^4}{\pi^4 Eh^4} + 0.370 \frac{w_{1,1}}{h} + 0.490 \left(\frac{w_{1,1}}{h}\right)^3 - 0.375 \left(\frac{w_{1,1}}{h}\right)^2 \left(\frac{w_{1,3}}{h}\right) + \dots \quad (17)$$

#### Magnitude of Edge Moments $m_x$ and $m_y$

The edge moments  $m_x$  and  $m_y$  must now be determined to satisfy the condition of zero slope at the edges of the plate. Setting the slope perpendicular to the edges  $x = 0$  and  $x = a$ , equal to zero gives

$$\left(\frac{\partial w}{\partial x}\right)_{x=0, x=a} = 0 = \sum_{m=1,3,5,\dots}^{\infty} \sum_{n=1,3,5,\dots}^{\infty} \frac{m\pi}{a} w_{m,n} \sin \frac{n\pi y}{a} \quad (18)$$

and setting the slope perpendicular to the edges  $y = 0$  and  $y = a$  to zero gives,

$$\left(\frac{\partial w}{\partial y}\right)_{y=0, y=a} = 0 = \sum_{m=1,3,5,\dots}^{\infty} \sum_{n=1,3,5,\dots}^{\infty} \frac{n\pi}{a} w_{m,n} \sin \frac{m\pi x}{a} \quad (19)$$

Equations (18) or (19) are equivalent to the family of equations

$$\left. \begin{aligned} 0 &= w_{1,1} + 3w_{1,3} + 5w_{1,5} + 7w_{1,7} + \dots \\ 0 &= w_{3,1} + 3w_{3,3} + 5w_{3,5} + 7w_{3,7} + \dots \\ 0 &= w_{5,1} + 3w_{5,3} + 5w_{5,5} + 7w_{5,7} + \dots \end{aligned} \right\} \quad (20)$$

The deflection coefficients  $w_{m,n}$  must now be determined from table 1 by solving each equation for the linear term in terms of the cubic terms and the pressure coefficients  $p_{r,s}$ . The deflection coefficients  $w_{m,n}$  thus obtained are now substituted into equations (20); and, for the pressure coefficients  $p_{r,s}$ , are substituted their values as given by equation (10). The resulting equations are,

$$\begin{aligned}
 0 &= 2.835 + 7.66k_1 + 0.324k_3 + 0.0800k_5 + 0.0393k_7 + 0.0145k_9 + \dots + K_1 \\
 0 &= 0.0523 + 0.324k_1 + 1.713k_3 + 0.1405k_5 + 0.0675k_7 + 0.0360k_9 + \dots + K_3 \\
 0 &= 0.00680 + 0.0800k_1 + 0.1405k_3 + 0.956k_5 + 0.0690k_7 + 0.0433k_9 + \dots + K_5 \\
 0 &= 0.001767 + 0.0303k_1 + 0.0675k_3 + 0.0690k_5 + 0.660k_7 + 0.0402k_9 + \dots + K_7 \\
 0 &= 0.000648 + 0.0145k_1 + 0.0360k_3 + 0.0433k_5 + 0.0402k_7 + 0.895k_9 + \dots + K_9
 \end{aligned} \tag{21}$$

where  $K_1 \dots K_9$  are functions of the pressure  $p$  and of the cubes of the deflection functions  $w_{m,n}$ . The first 22 terms in the equations for the first five coefficients  $K_r$  are given in table 2. As an example of the use of table 2,

$$\begin{aligned}
 K_1 = & -0.805 \frac{\pi^4 E h^4}{p a^4} \left( \frac{w_{1,1}}{h} \right)^3 + 0.0062 \frac{\pi^4 E h^4}{p a^4} \left( \frac{w_{1,1}}{h} \right)^2 \left( \frac{w_{1,3}}{h} \right) \\
 & + 0.107 \frac{\pi^4 E h^4}{p a^4} \left( \frac{w_{1,1}}{h} \right)^2 \left( \frac{w_{3,3}}{h} \right) - \dots \tag{22}
 \end{aligned}$$

### SOLUTION OF EQUATIONS

Values of Deflection Coefficients  $w_{m,n}$  and  
Edge Moment Coefficients  $k_r$

The method of obtaining the required values of the deflection coefficients  $w_{m,n}$  and the edge moment coefficients  $k_r$  consists of assuming values for  $\frac{w_{1,1}}{h}$  and then solving for  $\frac{w_{1,3}}{h}$ ,  $\frac{w_{3,3}}{h}$ ,  $\dots$ ,  $k_1$ ,  $k_3$ ,  $k_5$ ,  $\dots$ , by

successive approximation from the simultaneous equations in table 1 and equations (10) and (21). These calculations have been made for 10 values of  $\frac{w_{1,1}}{h}$ . The corresponding values of the first 36 deflection coefficients  $\frac{w_{m,n}}{h}$  and of the first five moment coefficients  $k_r$  are given in table 3 and table 4, respectively. The error arising from the use of only the first 22 terms in the equations in table 1 will be considered in a later section.

### Center Deflection

From equation (12) the center deflection is

$$w_{\text{center}} = \sum_{m=1, 3, 5, \dots}^{\infty} \sum_{n=1, 3, 5, \dots}^{\infty} -(-1)^{\frac{m+n}{2}} w_{m,n} \quad (23)$$

The center deflection was obtained by substituting the values of  $w_{m,n}$  from table 3 into equation (23) with the results given in table 5 and figure 3. Figure 3 shows that the deflection pressure curve deviates increasingly from a straight line with increasing deflection. The deviation exceeds 10 percent for deflections exceeding about one-half of the plate thickness.

### Shape of Deflected Surface

The lateral deflection of the plate is obtained by substituting the deflection coefficients  $w_{m,n}$  (table 3) into equation (12). This calculation has been made along the center line  $x = a/2$  for very small deflections

$\frac{w_{\text{center}}}{h} \ll 1$  and for the highest deflection calculated

$\frac{w_{\text{center}}}{h} = 1.902$  with the results given in figure 4. It

is apparent that, as the center deflection increases under increasing normal pressure, catenary tensions become appreciable and the inflection point is shifted toward the edges of the plate.

### Bending Stress at Midpoint of Edge

The extreme-fiber bending stress at the edge was obtained by substituting equations (6) into equations (3). This substitution gives, for the extreme-fiber bending stress perpendicular to the edge at its midpoint,

$$\left( \frac{\sigma'' a^2}{Eh^2} \right)_{\text{midpoint of edge}} = \frac{24}{\pi^3} \frac{pa^4}{Eh^4} (k_1 - k_3 + k_5 - k_7 + \dots) \quad (24)$$

The values of  $k_r$  and  $\frac{pa^4}{Eh^4}$  given in table 4 were substituted in equation (24) with the results given in table 5 and in figure 5. Figure 5 shows that the bending stress perpendicular to the edge at its midpoint deviates increasingly from a straight line with increasing pressure. The deviation exceeds 6 percent when the deflection is greater than one-half of the plate thickness.

### Bending Stress at Center of Plate

The extreme-fiber bending stresses are obtained by substituting equation (12) into equations (2). This substitution gives for the stress at the center of the plate in any direction,

$$\left( \frac{\sigma'' a^2}{Eh^2} \right)_{\text{center of plate}} = \frac{\pi^2}{2(1-\mu^2)} \sum_{m=1}^{\infty} \sum_{n=1}^{\infty} -(-1)^{\frac{m+n}{2}} (n^2 + \mu m^2) \frac{w_{m,n}}{h} \quad (25)$$

The values of  $\frac{w_{m,n}}{h}$  given in table 3 were substituted into equation (25) with the results given in table 5 and in figure 5. Figure 5 shows that the bending stress at the center of the plate is less than one-half of the bending stress perpendicular to the edge at its midpoint.

### Membrane Stresses

The membrane stresses in the plate are obtained by substituting equation (14) into equations (1) and using equations (15) and equations (16) to determine the values of the stress coefficients  $\sigma_x$ ,  $\sigma_y$ , and  $b_{m,n}$ . This substitution gives for the membrane stress perpendicular to the edge at its midpoint,

$$\begin{aligned}
\left(\frac{\sigma' a^2}{Eh^2}\right)_{\text{midpoint of edge}} &= 3.042 \left(\frac{w_{1,1}}{h}\right)^2 + 5.24 \left(\frac{w_{1,1}}{h}\right) \left(\frac{w_{1,3}}{h}\right) \\
&- 2.67 \left(\frac{w_{1,1}}{h}\right) \left(\frac{w_{3,3}}{h}\right) + 1.28 \left(\frac{w_{1,1}}{h}\right) \left(\frac{w_{1,5}}{h}\right) + 15.61 \left(\frac{w_{1,3}}{h}\right)^2 \\
&- 36.20 \left(\frac{w_{1,3}}{h}\right) \left(\frac{w_{3,3}}{h}\right) + 21.95 \left(\frac{w_{1,3}}{h}\right) \left(\frac{w_{1,5}}{h}\right) + 27.37 \left(\frac{w_{3,3}}{h}\right)^2 \\
&- 74.5 \left(\frac{w_{3,3}}{h}\right) \left(\frac{w_{1,5}}{h}\right) + 103.7 \left(\frac{w_{1,5}}{h}\right)^2 + \dots (26)
\end{aligned}$$

and, for the membrane stress at the center of the plate in any direction,

$$\begin{aligned}
\left(\frac{\sigma' a^2}{Eh^2}\right)_{\text{center of plate}} &= 3.042 \left(\frac{w_{1,1}}{h}\right)^2 - 5.44 \left(\frac{w_{1,1}}{h}\right) \left(\frac{w_{1,3}}{h}\right) \\
&+ 4.45 \left(\frac{w_{1,1}}{h}\right) \left(\frac{w_{3,3}}{h}\right) + 10.38 \left(\frac{w_{1,1}}{h}\right) \left(\frac{w_{1,5}}{h}\right) + 55.09 \left(\frac{w_{1,3}}{h}\right)^2 \\
&- 55.06 \left(\frac{w_{1,3}}{h}\right) \left(\frac{w_{3,3}}{h}\right) - 93.98 \left(\frac{w_{1,3}}{h}\right) \left(\frac{w_{1,5}}{h}\right) + 27.37 \left(\frac{w_{3,3}}{h}\right)^2 \\
&+ 100.8 \left(\frac{w_{3,3}}{h}\right) \left(\frac{w_{1,5}}{h}\right) + 143.3 \left(\frac{w_{1,5}}{h}\right)^2 + \dots (27)
\end{aligned}$$

The values of  $\frac{w_{m,n}}{h}$  given in table 3 have been substituted into equations (26) and (27) with the results given in table 5 and in figure 5. Figure 5 shows that for pressures less than the maximum computed  $\left(\frac{pa^4}{4} < 402\right)$ , the membrane stresses are smaller than the corresponding extreme-fiber bending stresses and that they change only a small amount in going from the edge to the center of the plate.

## Convergence of Solution

An exact solution would require the use of an infinite number of terms in the equations of tables 1 and 2. In the present solution only the first 22 terms were used. The effect of limiting the number of terms is brought out by the comparison in table 6 of the solution for 2, 3, 6, and 22 terms. For example, the use of only the first six terms in the first equation of table 1, excluding cubic terms

involving  $\frac{w_{3,3}}{h}$ ,  $\frac{w_{1,5}}{h}$ , etc., as factors, gives the equation

$$0 = -\frac{p_{1,1}a^4}{\pi^4 E h^4} + 0.370 \frac{w_{1,1}}{h} + 0.490 \left(\frac{w_{1,1}}{h}\right)^3 - 0.375 \left(\frac{w_{1,1}}{h}\right)^2 \left(\frac{w_{1,3}}{h}\right) + 6.28 \left(\frac{w_{1,1}}{h}\right) \left(\frac{w_{1,3}}{h}\right)^2 - 3.25 \left(\frac{w_{1,3}}{h}\right)^3 \quad (28a)$$

the use of only the first three terms in the first equation of table 1, excluding cubic terms involving  $\frac{w_{1,3}}{h}$ ,  $\frac{w_{3,3}}{h}$ ,  $\frac{w_{1,5}}{h}$ , etc., as factors, gives the equation

$$0 = \frac{-p_{1,1}a^4}{\pi^4 E h^4} + 0.370 \frac{w_{1,1}}{h} + 0.490 \left(\frac{w_{1,1}}{h}\right)^3 \quad (28b)$$

and the use of only the first two terms in the first equation of table 1, excluding all cubic terms, gives the equation

$$0 = -\frac{p_{1,1}a^4}{\pi^4 E h^4} + 0.370 \frac{w_{1,1}}{h} \quad (28c)$$

It is evident from table 6 that the convergence is rapid for the center deflection. The convergence is somewhat slower in the case of the bending stress at the midpoint of the edge. It is estimated from table 6 that the possible error in table 5 is less than 2 percent.

## COMPARISON WITH THE RESULTS OBTAINED BY PREVIOUS AUTHORS

## The Clamped Rectangular Plate with Small Deflections

The earliest work on the problem of the clamped rectangular plate known to the author is that in 1902 by Koialovich (reference 7). Koialovich solved the problem by using trigonometric series. In 1913 Hencky (reference 2), using a method which he credits to M. Levy, made a thorough analysis of the moments and deflections for plates with small deflections. In 1914 Boobnov (see p. 222 of reference 4) extended the scope of Koialovich's earlier work. Since that time additional work on the problem extending the analysis to different types of loading and a wider range of plate sizes has been done by Nadai (reference 8), Timoshenko (references 4 and 9), Wojtaszak (reference 10), Evans (reference 11), Young (reference 12), and Pickett (reference 13). The results of these authors for the square plate with clamped edges agree closely with Hencky's results presented in reference 2. The present paper gives, for small deflections, a value of the center deflection of  $0.001263 \text{ pa}^4/D$  as compared with Hencky's value of  $0.001265 \text{ pa}^4/D$ ; and a value of the bending moment perpendicular to the edge at midpoint of  $0.0512 \text{ a}^2\text{p}$  compared with Hencky's value of  $0.0513 \text{ a}^2\text{p}$ .

## The Clamped Rectangular Plate with Large Deflections

The only previous analysis of square plates with clamped edges under normal pressure producing large deflections that is known to the author is the analysis by Way (reference 3) in which the Ritz energy method is used with polynomials satisfying the boundary conditions and containing 11 undetermined constants. Although his calculations were made for a Poisson's ratio of 0.3, it appears from Way's analysis of circular plates (reference 15) that small changes in Poisson's ratio do not appreciably alter the solution. In figures 6 and 7 are compared the results obtained by Way in reference 3 with  $\mu = 0.3$  and the results of the present paper with  $\mu = 0.316$ . The agreement is excellent (within 5 percent) for both the total stress at the middle of the side and the center deflection. The agreement between the membrane stresses is not so good. In no case, however, do the membrane stresses differ by more than 4 percent of the total stress.

### The Infinite Plate Strip and the Circular Plate

The values of the center deflection and of the extreme-fiber stresses at the center of the sides for a square clamped plate with large deflection are compared in figures 8 and 9 with those for a clamped circular plate (reference 14) of diameter  $a$  and those for a clamped long rectangular plate (references 4 and 15) of width  $a$ . As would be expected, the square plate is more rigid than the long rectangular plate and more flexible than the circular plate.

### NUMERICAL EXAMPLES

#### Example 1

Calculate the center deflection and the maximum extreme-fiber stress for a 10- by 10- by 0.05-inch aluminum-alloy plate ( $E = 10^7$  lb/in<sup>2</sup>,  $\mu = 0.316$ ) with clamped edges, subjected to a normal pressure of 2 pounds per square inch.

The pressure ratio is:

$$\frac{pa^4}{Eh^4} = \frac{2 \times 10^4}{10^7 \times (0.05)^4} = 320$$

From figure 3, the corresponding deflection ratio is

$$\frac{w_{\text{center}}}{h} = 1.72$$

so that the center deflection is

$$w_{\text{center}} = 1.72 \times 0.05 = 0.0860 \text{ inch}$$

From figure 5, the maximum extreme-fiber stress ratio for the edge at its midpoint is

$$\frac{\sigma a^2}{Eh^2} = 65.0$$

so that the maximum extreme-fiber stress is



$$\sigma = 65.0 \frac{10^7 \cdot x \cdot (0.05)^2}{10^2} = 16,300 \text{ pounds per square inch}$$

## Example 2

Calculate the pressure that will produce a maximum extreme-fiber stress of 30,000 pounds per square inch in a 15- by 15- by 0.10-inch aluminum-alloy plate with clamped edges.

The maximum extreme-fiber stress ratio is,

$$\frac{\sigma a^2}{Eh^2} = \frac{30000 \times 15^2}{10^7 \times (0.10)^2} = 67.5$$

From figure 5, the corresponding pressure ratio is

$$\frac{pa^4}{Eh^4} = 339$$

so that the normal pressure is

$$p = \frac{339 \times 10^7 \times (0.10)^4}{15^4} = 6.70 \text{ pounds per square inch}$$

National Bureau of Standards,  
Washington, D. C., May 24, 1941.

## REFERENCES

1. Levy, S.: Bending of Rectangular Plates with Large Deflections. T.N. No. 846, NACA, 1942.
2. Hencky, H. Über den Spannungszustand in rechteckigen ebenen Platten. Doctor's diss., Darmstadt, R. Oldenbourg (Munich), 1913.
3. Way, Stewart: Uniformly Loaded, Clamped, Rectangular Plates with Large Deflection. Proc., Fifth Int. Cong. Appl. Mech. (Cambridge, Mass., 1938). John Wiley & Sons, Inc., 1939, pp. 123-28.
4. Timoshenko, S.: Theory of Plates and Shells. McGraw-Hill Book Co., Inc., 1940.
5. Woods, F. S.: Advanced Calculus. Ginn and Co., 1926.
6. von Kármán, Th.: Festigkeitsprobleme in Maschinenbau. vol. IV, pt. 4, of Encyk. der Math. Wiss., 1910, art. 27, pp. 311-85.
7. Koialovich, Boris Mikhailovich: Ob odnum uravnenii chastn' imi' proizvodn' imi' chetvertago poriadka. Doctorial diss., Sankt., (Petersburg), 1902.
8. Náđai, A.: Elastische Platten. Julius Springer (Berlin), 1925, pp. 180-84.
9. Timoshenko, Stephen P.: Bending of Rectangular Plates with Clamped Edges. Proc., Fifth Int. Cong. Appl. Mech. (Cambridge, Mass., 1938). John Wiley & Sons, Inc., 1939, pp. 40-43.
10. Wojtaszak, I. A.: The Calculation of Maximum Deflection, Moment, and Shear for Uniformly Loaded Rectangular Plate with Clamped Edges. Jour. Appl. Mech., vol. 4, no. 4, Dec. 1937, pp. A-173-A-176.
11. Evans, Thomas H.: Tables of Moments and Deflections for a Rectangular Plate Fixed on All Edges and Appl. Mech., vol. 6, no. 1, March 1939, pp. A-7-A-10.
12. Young, Dana: Clamped Rectangular Plates with a Central Concentrated Load. Jour. Appl. Mech., vol. 6, no. 3, Sept. 1939, pp. A-114-A-116.

13. Pickett, Gerald: Solution of Rectangular Clamped Plate with Lateral Load by Generalized Energy Method. Jour. Appl. Mech., vol. 6, no. 4, Dec. 1939, pp. A-168--A-170.
14. Way, Stewart: Bending of Circular Plates with Large Deflection. A.S.M.E. Trans., APM-56-12, vol. 56, no. 8, Aug. 1934, pp. 627-636.
15. Boobnov, Ivan G.: On the Stresses in a Ship's Bottom Plating Due to Water Pressure. Trans. Inst. Naval Arch., vol. XLIV, 1902, pp. 15-52.

TABLE I.- EQUATIONS BETWEEN DEFLECTION COEFFICIENTS  $w_{m,n}$  AND PRESSURE COEFFICIENTS  $P_{r,s}$   
WHEN POISSON'S RATIO EQUALS 0.316  
[Only the first 22 terms have been retained in these equations]

	0 =	0 =	0 =	0 =	0 =	0 =	0 =	0 =
$\frac{a^4}{\pi^4 E h^4}$	$-P_{1,1}$	$-P_{1,3}$	$-P_{3,3}$	$-P_{1,5}$	$-P_{1,7}$	$-P_{1,9}$	$-P_{1,11}$	$-P_{1,13}$
1	$0.370 \frac{w_{1,1}}{h}$	$9.26 \frac{w_{1,3}}{h}$	$30.0 \frac{w_{3,3}}{h}$	$62.5 \frac{w_{1,5}}{h}$	$231 \frac{w_{1,7}}{h}$	$623 \frac{w_{1,9}}{h}$	$1378 \frac{w_{1,11}}{h}$	$2875 \frac{w_{1,13}}{h}$
$\left(\frac{w_{1,1}}{h}\right)^3$	.490	-.0625	0	0	0	0	0	0
$\left(\frac{w_{1,1}}{h}\right)^2 \frac{w_{1,3}}{h}$	-.375	3.142	-1.17	-.210	0	0	0	0
$\left(\frac{w_{1,1}}{h}\right)^2 \frac{w_{3,3}}{h}$	0	-.585	3.690	.2025	0	0	0	0
$\left(\frac{w_{1,1}}{h}\right)^2 \frac{w_{1,5}}{h}$	0	-.210	.405	6.76	-.2275	0	0	0
$\frac{w_{1,1}}{h} \left(\frac{w_{1,3}}{h}\right)^2$	6.26	-4.875	5.625	2.872	-.250	0	0	0
$\frac{w_{1,1}}{h} \frac{w_{1,3}}{h} \frac{w_{3,3}}{h}$	-2.34	5.625	0	-7.02	1.125	0	0	0
$\frac{w_{1,1}}{h} \frac{w_{1,3}}{h} \frac{w_{1,5}}{h}$	-.840	5.745	-14.04	-5.65	6.33	-.593	0	0
$\frac{w_{1,1}}{h} \left(\frac{w_{3,3}}{h}\right)^2$	3.690	0	0	2.385	-2.385	0	0	0
$\frac{w_{1,1}}{h} \frac{w_{3,3}}{h} \frac{w_{1,5}}{h}$	.910	-7.02	9.54	3.645	-1.979	1.900	0	0
$\frac{w_{1,1}}{h} \left(\frac{w_{1,5}}{h}\right)^2$	13.53	-2.825	3.645	0	0	1.288	-.347	0
$\left(\frac{w_{1,3}}{h}\right)^3$	-3.25	30.77	-10.125	-8.625	1.5825	-.0625	0	0
$\left(\frac{w_{1,3}}{h}\right)^2 \frac{w_{3,3}}{h}$	5.625	-15.19	76.1	16.79	-11.090	.610	0	0
$\left(\frac{w_{1,3}}{h}\right)^2 \frac{w_{1,5}}{h}$	5.745	-25.875	33.58	89.5	-18.84	4.54	-.1981	0
$\frac{w_{1,3}}{h} \left(\frac{w_{3,3}}{h}\right)^2$	0	38.08	0	0	0	-4.55	0	0
$\frac{w_{1,3}}{h} \frac{w_{3,3}}{h} \frac{w_{1,5}}{h}$	-14.04	33.58	0	-85.13	37.76	-15.00	2.346	0
$\frac{w_{1,3}}{h} \left(\frac{w_{1,5}}{h}\right)^2$	-5.65	89.5	-85.13	-40.875	30.98	-8.00	2.56	-.2050
$\left(\frac{w_{3,3}}{h}\right)^3$	0	0	39.68	0	0	0	0	0
$\left(\frac{w_{3,3}}{h}\right)^2 \frac{w_{1,5}}{h}$	4.77	0	0	101.2	-16.41	0	-6.32	0
$\frac{w_{3,3}}{h} \left(\frac{w_{1,5}}{h}\right)^2$	3.645	-42.57	202.4	0	-62.4	26.68	0	1.42
$\left(\frac{w_{1,5}}{h}\right)^3$	0	-13.63	0	207.9	-28.6	0	0	0

TABLE I (Continued)

	0 =	0 =	0 =	0 =	0 =	0 =	0 =	0 =
$\frac{a^4}{n^4 h^4}$	$-P_{1,15}$	$-P_{3,5}$	$-P_{3,7}$	$-P_{3,9}$	$-P_{3,11}$	$-P_{3,13}$	$-P_{5,5}$	$-P_{5,7}$
1	$4730 \frac{w_{1,15}}{h}$	$107 \frac{w_{3,5}}{h}$	$311 \frac{w_{3,7}}{h}$	$750 \frac{w_{3,9}}{h}$	$1565 \frac{w_{3,11}}{h}$	$2930 \frac{w_{3,13}}{h}$	$231 \frac{w_{5,5}}{h}$	$508 \frac{w_{5,7}}{h}$
$\left(\frac{w_{1,1}}{h}\right)^3$	0	0	0	0	0	0	0	0
$\left(\frac{w_{1,1}}{h}\right)^2 \frac{w_{1,3}}{h}$	0	.0025	0	0	0	0	0	0
$\left(\frac{w_{1,1}}{h}\right)^2 \frac{w_{3,3}}{h}$	0	-.584	0	0	0	0	0	0
$\left(\frac{w_{1,1}}{h}\right)^2 \frac{w_{1,5}}{h}$	0	-1.624	.0100	0	0	0	0	0
$\frac{w_{1,1}}{h} \left(\frac{w_{1,3}}{h}\right)^2$	0	-2.059	.0025	0	0	0	.125	0
$\frac{w_{1,1}}{h} \frac{w_{1,3}}{h} \frac{w_{3,3}}{h}$	0	2.590	-1.320	0	0	0	-1.291	.0258
$\frac{w_{1,1}}{h} \frac{w_{1,3}}{h} \frac{w_{1,5}}{h}$	0	12.683	-4.066	.0244	0	0	-8.780	.3806
$\frac{w_{1,1}}{h} \left(\frac{w_{3,3}}{h}\right)^2$	0	0	0	0	0	0	0	-.2025
$\frac{w_{1,1}}{h} \frac{w_{3,3}}{h} \frac{w_{1,5}}{h}$	0	-3.287	4.310	-1.688	0	0	0	-2.226
$\frac{w_{1,1}}{h} \left(\frac{w_{1,5}}{h}\right)^2$	0	-8.650	4.925	-.2025	.0100	0	15.625	-6.646
$\left(\frac{w_{1,3}}{h}\right)^3$	0	4.62	-1.624	0	0	0	-3.125	.250
$\left(\frac{w_{1,3}}{h}\right)^2 \frac{w_{3,3}}{h}$	0	-15.45	0	-.831	0	0	4.50	-2.405
$\left(\frac{w_{1,3}}{h}\right)^2 \frac{w_{1,5}}{h}$	0	-31.08	20.82	-5.404	.00022	0	17.25	-13.41
$\frac{w_{1,3}}{h} \left(\frac{w_{3,3}}{h}\right)^2$	0	18.42	-15.93	0	0	0	0	0
$\frac{w_{1,3}}{h} \frac{w_{3,3}}{h} \frac{w_{1,5}}{h}$	0	83.90	-10.04	0	-2.358	0	-67.54	9.82
$\frac{w_{1,3}}{h} \left(\frac{w_{1,5}}{h}\right)^2$	0	31.84	-46.15	24.82	-3.78	.00022	0	33.10
$\left(\frac{w_{3,3}}{h}\right)^3$	0	0	0	-5.06	0	0	0	0
$\left(\frac{w_{3,3}}{h}\right)^2 \frac{w_{1,5}}{h}$	0	0	0	0	0	0	36.0	-17.69
$\frac{w_{3,3}}{h} \left(\frac{w_{1,5}}{h}\right)^2$	0	-39.7	63.41	-18.54	0	-1.681	0	-16.40
$\left(\frac{w_{1,5}}{h}\right)^3$	-.0625	-39.0	0	-20.25	10.56	0	0	0

TABLE I (Continued)

Others

	0 =	0 =	0 =	0 =	0 =	0 =	0 =	0 =
$\frac{a^4}{\pi^4 E h^4}$	$-P_{5,9}$	$-P_{5,11}$	$-P_{5,13}$	$-P_{7,7}$	$-P_{7,9}$	$-P_{7,11}$	$-P_{9,9}$	$-P_{r,s}$
1	$1040 \frac{w_{5,9}}{h}$	$1971 \frac{w_{5,11}}{h}$	$3485 \frac{w_{5,13}}{h}$	$889 \frac{w_{7,7}}{h}$	$1565 \frac{w_{7,9}}{h}$	$2675 \frac{w_{7,11}}{h}$	$2430 \frac{w_{9,9}}{h}$	$\frac{(r^2+s^2)^2}{10.8} \frac{w_{r,s}}{h}$
$\left(\frac{w_{1,1}}{h}\right)^3$	0	0	0	0	0	0	0	0
$\left(\frac{w_{1,1}}{h}\right)^2 \frac{w_{1,3}}{h}$	0	0	0	0	0	0	0	0
$\left(\frac{w_{1,1}}{h}\right)^2 \frac{w_{3,3}}{h}$	0	0	0	0	0	0	0	0
$\left(\frac{w_{1,1}}{h}\right)^2 \frac{w_{1,5}}{h}$	0	0	0	0	0	0	0	0
$\frac{w_{1,1}}{h} \left(\frac{w_{1,3}}{h}\right)^2$	0	0	0	0	0	0	0	0
$\frac{w_{1,1}}{h} \frac{w_{1,3}}{h} \frac{w_{3,3}}{h}$	0	0	0	0	0	0	0	0
$\frac{w_{1,1}}{h} \frac{w_{1,3}}{h} \frac{w_{1,5}}{h}$	0	0	0	0	0	0	0	0
$\frac{w_{1,1}}{h} \left(\frac{w_{3,3}}{h}\right)^2$	0	0	0	0	0	0	0	0
$\frac{w_{1,1}}{h} \frac{w_{3,3}}{h} \frac{w_{1,5}}{h}$	.1125	0	0	0	0	0	0	0
$\frac{w_{1,1}}{h} \left(\frac{w_{1,5}}{h}\right)^2$	0	0	0	.980	0	0	0	0
$\left(\frac{w_{1,3}}{h}\right)^3$	0	0	0	0	0	0	0	0
$\left(\frac{w_{1,3}}{h}\right)^2 \frac{w_{3,3}}{h}$	.0299	0	0	.326	0	0	0	0
$\left(\frac{w_{1,3}}{h}\right)^2 \frac{w_{1,5}}{h}$	1.189	0	0	1.774	0	0	0	0
$\frac{w_{1,3}}{h} \left(\frac{w_{3,3}}{h}\right)^2$	-.810	0	0	0	.0299	0	0	0
$\frac{w_{1,3}}{h} \frac{w_{3,3}}{h} \frac{w_{1,5}}{h}$	-4.52	.203	0	-11.02	1.286	0	0	0
$\frac{w_{1,3}}{h} \left(\frac{w_{1,5}}{h}\right)^2$	-20.91	.887	0	-22.00	4.14	0	0	0
$\left(\frac{w_{3,3}}{h}\right)^3$	0	0	0	0	0	0	0	0
$\left(\frac{w_{3,3}}{h}\right)^2 \frac{w_{1,5}}{h}$	0	-1.418	0	0	0	.2025	0	0
$\frac{w_{3,3}}{h} \left(\frac{w_{1,5}}{h}\right)^2$	0	0	.2025	15.45	-9.60	0	3.64	0
$\left(\frac{w_{1,5}}{h}\right)^3$	28.58	-13.62	0	0	-10.56	4.00	0	0

TABLE II.- EQUATIONS BETWEEN THE MOMENT COEFFICIENTS  $K_r$  IN EQUATION (21),  
THE DEFLECTION COEFFICIENTS  $w_{m,n}$  AND THE NORMAL PRESSURE  $p$

	$\frac{pa^4}{\pi^4 Eh^4} K_1$ =	$\frac{pa^4}{\pi^4 Eh^4} K_3$ =	$\frac{pa^4}{\pi^4 Eh^4} K_5$ =	$\frac{pa^4}{\pi^4 Eh^4} K$ =	$\frac{pa^4}{\pi^4 Eh^4} K_9$ =
$\left(\frac{w_{1,1}}{h}\right)^3$	-0.805	0.00417	0	0	0
$\left(\frac{w_{1,1}}{h}\right)^2 \frac{w_{1,3}}{h}$	.0062	-.138	.00203	0	0
$\left(\frac{w_{1,1}}{h}\right)^2 \frac{w_{3,3}}{h}$	.107	-.172	.00812	0	0
$\left(\frac{w_{1,1}}{h}\right)^2 \frac{w_{1,5}}{h}$	-.2875	.0357	-.0386	.000549	0
$\frac{w_{1,1}}{h} \left(\frac{w_{1,3}}{h}\right)^2$	-9.63	.0373	.0056	.000652	0
$\frac{w_{1,1}}{h} \frac{w_{1,3}}{h} \frac{w_{3,3}}{h}$	3.10	-.431	.0415	.00469	0
$\frac{w_{1,1}}{h} \frac{w_{1,3}}{h} \frac{w_{1,5}}{h}$	.42	.175	.0486	.0049	.00053
$\frac{w_{1,1}}{h} \left(\frac{w_{3,3}}{h}\right)^2$	-6.24	0	-.0219	.00764	0
$\frac{w_{1,1}}{h} \frac{w_{3,3}}{h} \frac{w_{1,5}}{h}$	-.27	-.073	.0394	-.00679	.00195
$\frac{w_{1,1}}{h} \left(\frac{w_{1,5}}{h}\right)^2$	-23.05	.146	-.0025	.00649	-.00078
$\left(\frac{w_{1,3}}{h}\right)^3$	-.33	-1.54	.0448	.00398	.00006
$\left(\frac{w_{1,3}}{h}\right)^2 \frac{w_{3,3}}{h}$	-6.97	-3.24	.0618	.0427	.00116
$\left(\frac{w_{1,3}}{h}\right)^2 \frac{w_{1,5}}{h}$	-8.50	.302	-.468	-.0005	.0053
$\frac{w_{1,3}}{h} \left(\frac{w_{3,3}}{h}\right)^2$	-7.59	-2.84	-.315	.0948	.00683
$\frac{w_{1,3}}{h} \frac{w_{3,3}}{h} \frac{w_{1,5}}{h}$	20.35	-4.51	.232	-.0519	.0248
$\frac{w_{1,3}}{h} \left(\frac{w_{1,5}}{h}\right)^2$	-7.01	-1.15	-.321	.0821	-.0048
$\left(\frac{w_{3,3}}{h}\right)^3$	0	-2.41	0	0	.0125
$\left(\frac{w_{3,3}}{h}\right)^2 \frac{w_{1,5}}{h}$	-12.62	.0	-1.324	.1512	0
$\frac{w_{3,3}}{h} \left(\frac{w_{1,5}}{h}\right)^2$	3.36	-9.25	.826	-.152	.0375
$\left(\frac{w_{1,5}}{h}\right)^3$	-6.99	2.14	-1.482	.1038	-.0056

TABLE 4.- VALUES OF EDGE MOMENT COEFFICIENTS  $k_1, k_3$   
AS FUNCTIONS OF THE NORMAL PRESSURE  $p$

$\frac{pa^4}{Eh^4}$	$k_1$	$k_3$	$k_5$	$k_7$	$k_9$
0	-0.372	0.0379	0.0177	0.0084	0.0045
17.8	-.366	.0362	.0171	.0084	.0045
38.3	-.352	.0325	.0162	.0083	.0045
63.4	-.330	.0269	.0151	.0080	.0044
95.0	-.308	.0214	.0138	.0076	.0043
134.9	-.286	.0160	.0125	.0073	.0042
184.0	-.265	.0115	.0111	.0069	.0041
245.0	-.247	.0079	.0099	.0066	.0039
318.0	-.230	.0046	.0087	.0063	.0038
402.0	-.215	.0020	.0077	.0060	.0036

TABLE 6.- CONVERGENCE OF SOLUTION AS THE NUMBER OF TERMS USED  
IN THE EQUATIONS OF TABLES 1 AND 2 ARE INCREASED FROM 2 TO 22

$\frac{pa^4}{Eh^4}$	Using 2 terms	Using 3 terms	Using 6 terms	Using 22 terms
Center deflection $w_{center}/h$				
63.4	0.87	0.76	0.702	0.695
184.0	2.52	1.50	1.34	1.323
402.0	5.51	2.15	1.94	1.902
Bending stress perpendicular to edge at its midpoint $\sigma''a^2/Eh^2$				
63.4	19.4	16.9	16.6	16.97
184.0	56.3	36.1	37.2	38.2
402.0	123.1	59.5	63.6	66.2



TABLE 5.- CENTER DEFLECTION, BENDING STRESSES  $\sigma''$ , MEMBRANE STRESSES  $\sigma'$ , AND EXTREME-FIBER STRESSES  $\sigma$  AS A FUNCTION OF THE LATERAL PRESSURE  $p$ .

$$[\mu = 0.316]$$

Pressure	Center deflection	Stress at midpoint of edge (perpendicular to edge)			Stress at center of plate in any direction		
		$\frac{\sigma'' a^2}{Eh^2}$	$\frac{\sigma' a^2}{Eh^2}$	$\frac{\sigma a^2}{Eh^2}$	$\frac{\sigma'' a^2}{Eh^2}$	$\frac{\sigma' a^2}{Eh^2}$	$\frac{\sigma a^2}{Eh^2}$
0	0	0	0	0	0	0	0
17.79	.237	5.36	.12	5.48	2.5	.14	2.6
38.3	.471	11.05	.47	11.52	4.6	.62	5.2
63.4	.695	16.97	1.06	18.03	6.7	1.33	8.0
95.0	.912	23.45	1.87	25.32	8.8	2.27	11.1
134.9	1.121	30.6	2.92	33.5	9.9	3.43	13.3
184.0	1.323	38.2	4.23	42.4	11.1	4.79	15.9
245.0	1.521	47.0	5.78	52.8	12.9	6.34	19.2
318.0	1.714	56.3	7.60	63.9	13.8	8.08	21.9
402.0	1.902	66.2	9.64	75.8	15.1	10.02	25.1

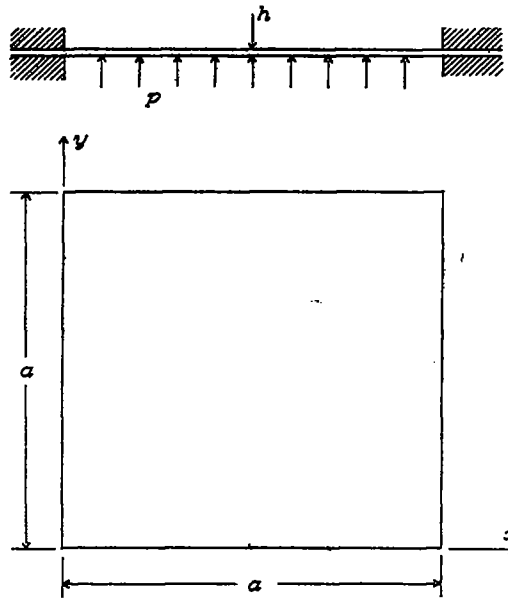

Figure 1.- Uniform normal pressure on a clamped square plate.

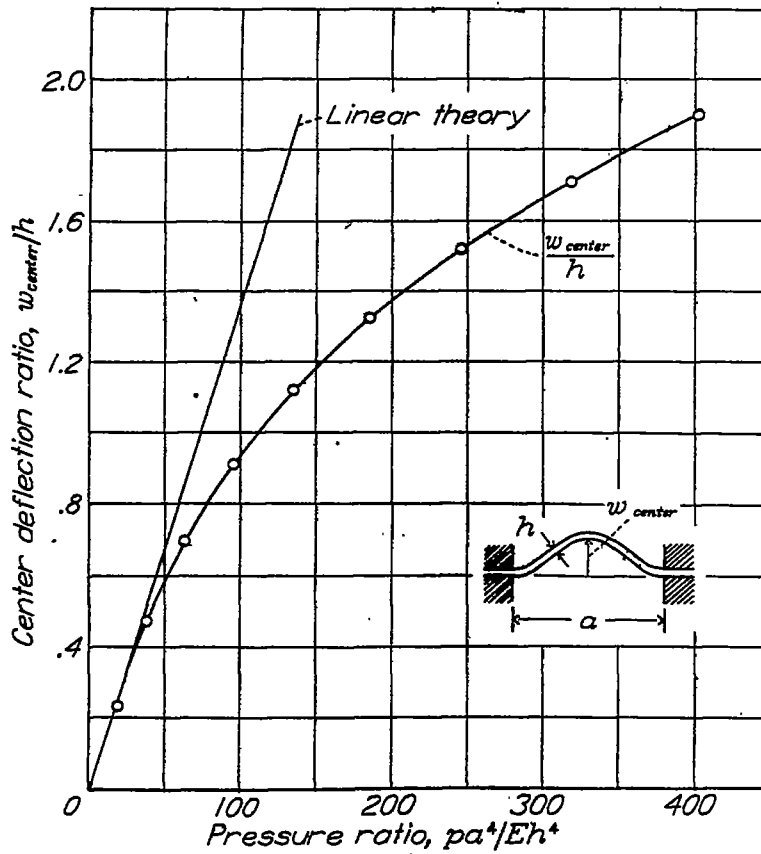

Figure 3.- Center deflection of square plate with clamped edges.  $\mu = 0.316$ .

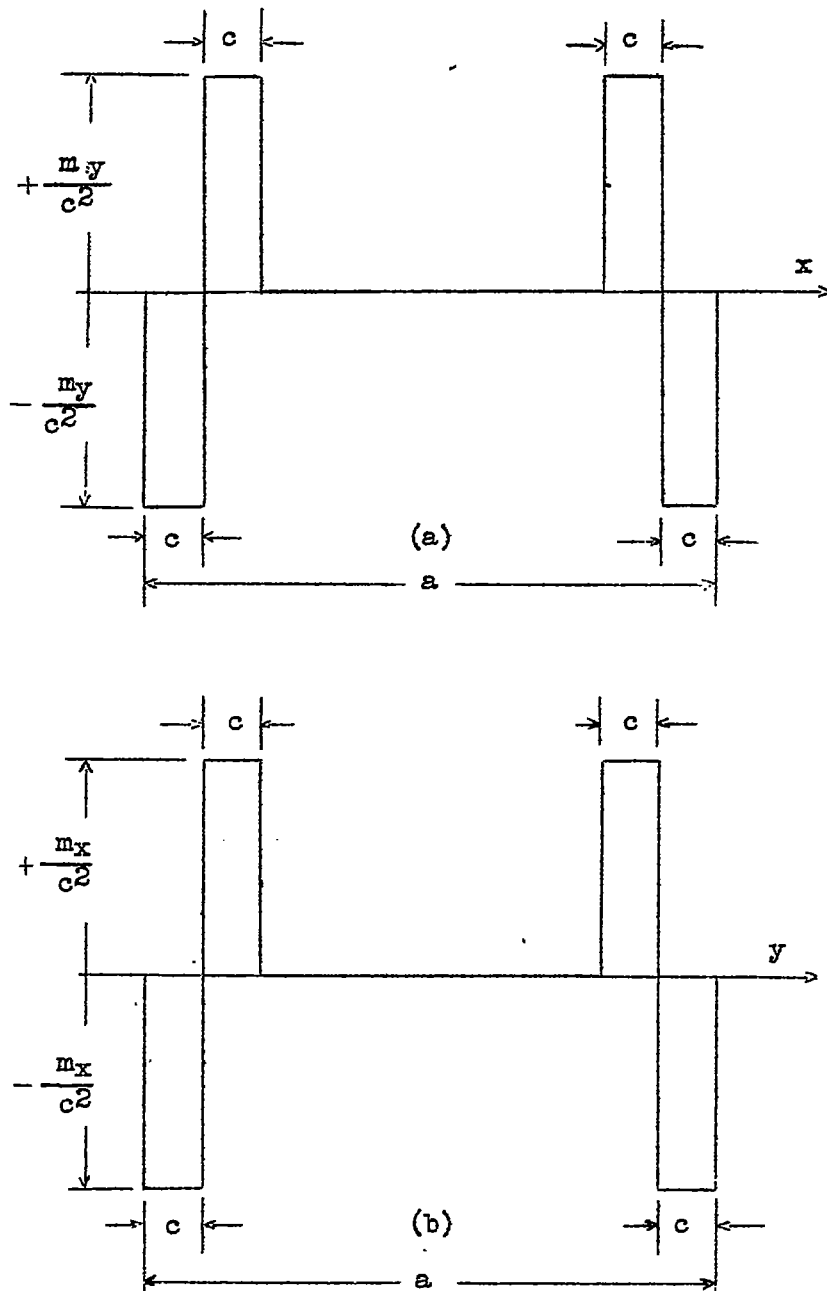
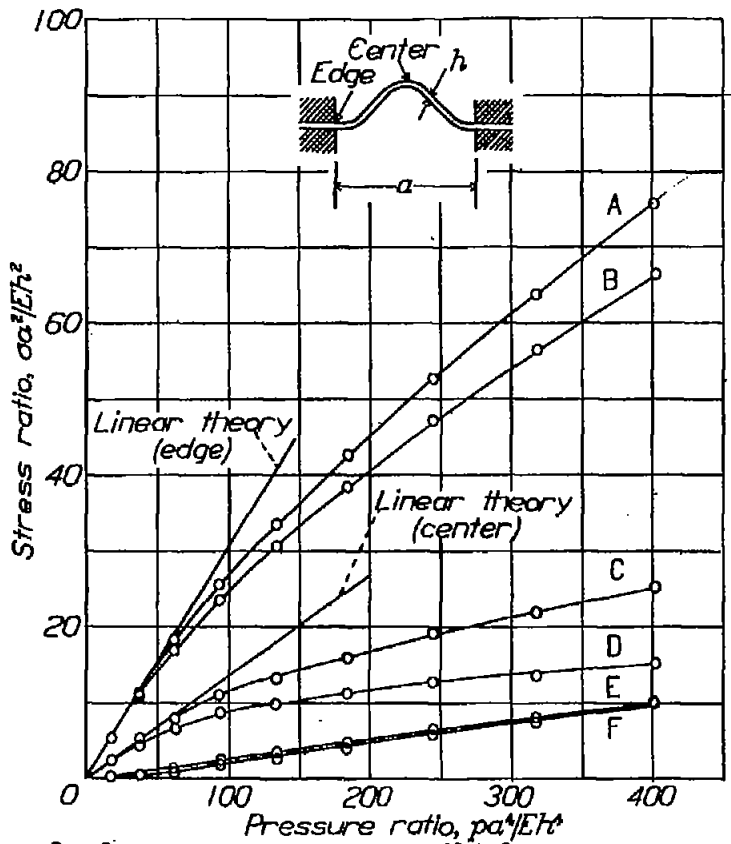

Figure 2.- Auxiliary pressure distribution for applying edge moments along the edges (a)  $x = 0$ ,  $x = a$ ; (b)  $y = 0$ ,  $y = a$ .



A,  $\sigma_a^2/Eh^2$  midpoint of (edge)    B,  $\sigma_a^2/Eh^2$  midpoint of (edge)  
 C,  $\sigma_a^2/Eh^2$  (center)    D,  $\sigma_a^2/Eh^2$  (center)  
 E,  $\sigma_a^2/Eh^2$  (center)    F,  $\sigma_a^2/Eh^2$  midpoint of (edge)

Figure 5.- Stresses perpendicular to edge at its midpoint and at the center of a clamped square plate in any direction.  
 $\mu = 0.318$ .  $\sigma_a^2/Eh^2$  = extreme fiber bending stress ratio  
 $\sigma_a^2/Eh^2$  = membrane stress ratio  
 $\sigma_a^2/Eh^2$  = extreme-fiber stress ratio  
 $pa^4/Eh^4$  = pressure ratio

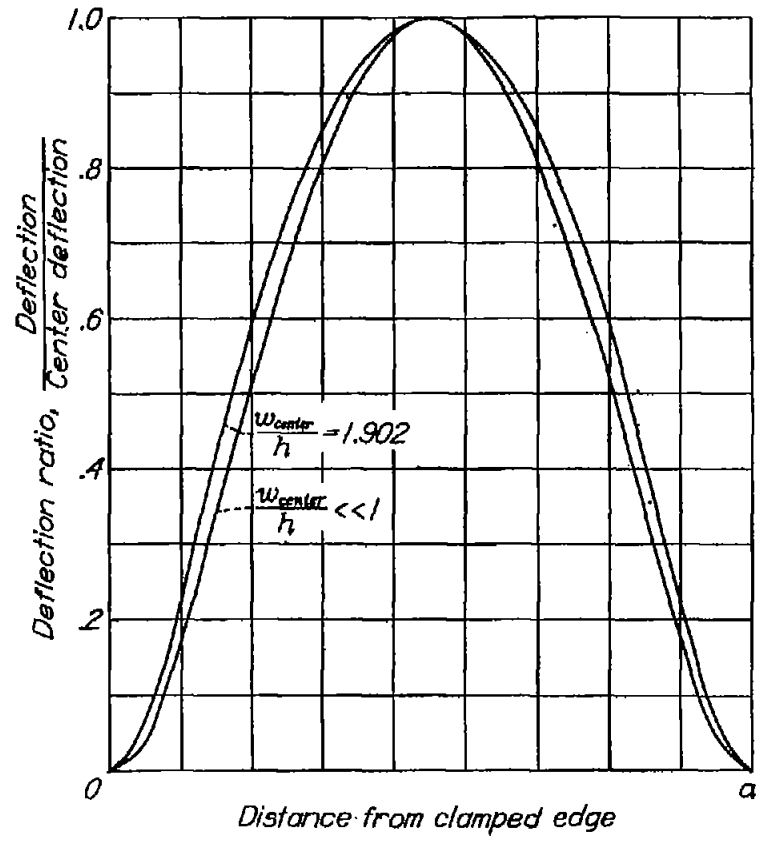

Figure 4.- Shape of deflected surface along center line  $x = a/2$  for very small deflection  $w_{center}/h \ll 1$  and for the largest deflection calculated  $w_{center}/h = 1.908$ .

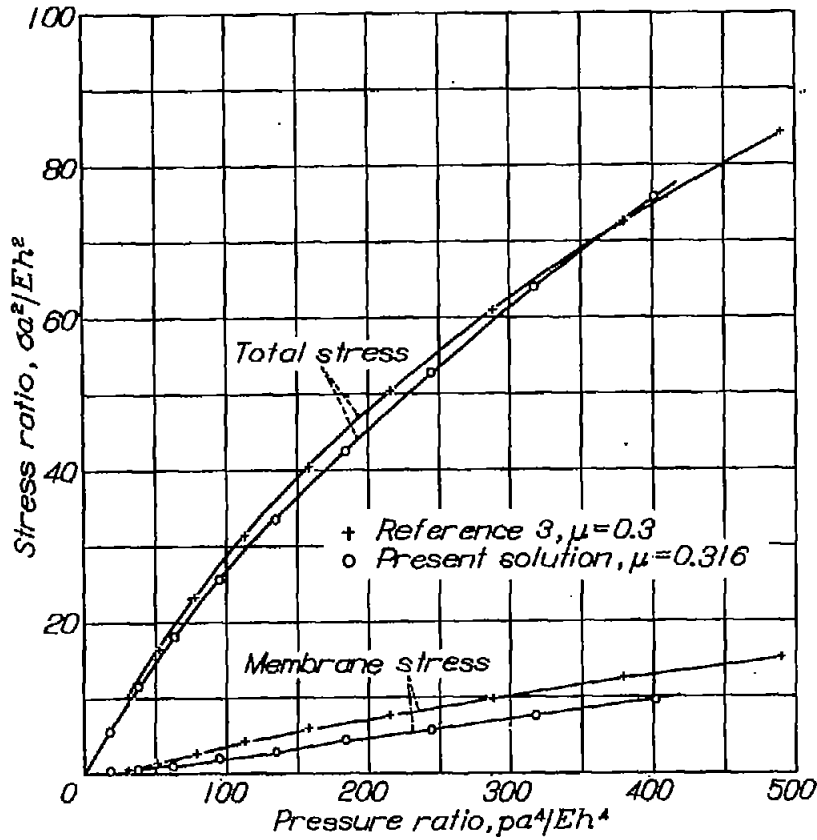

Figure 7.- Comparison of Way's solution (reference 3) using the Ritz energy method and the present solution for the total stress and the membrane stress perpendicular to the edge at its midpoint.

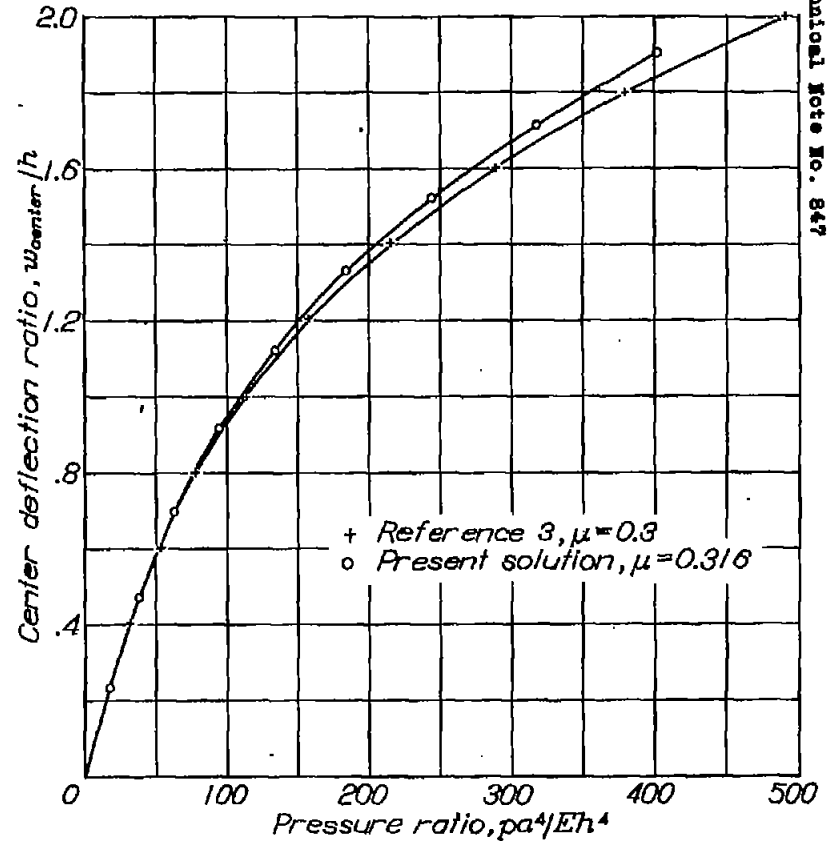

Figure 6.- Comparison of Way's solution (reference 3) using the Ritz energy method and the present solution for the center deflection.

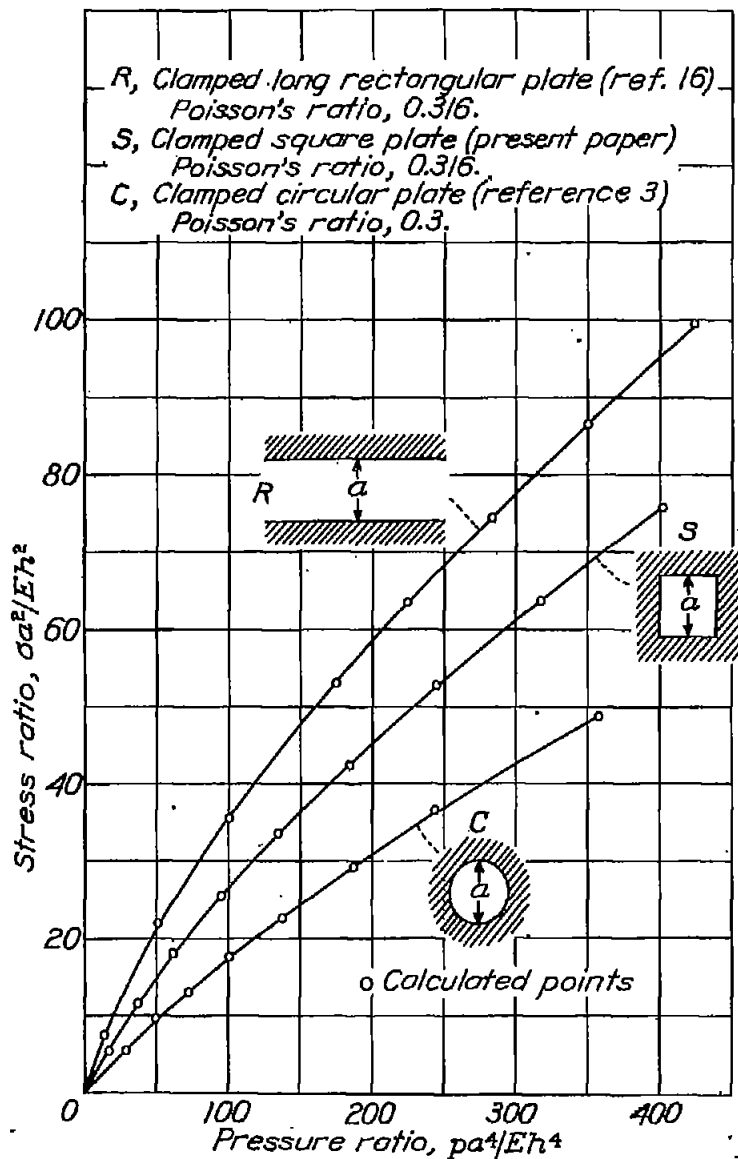

Figure 9.- Variation of maximum extreme fiber stress at edge with pressure for square plate, circular plate, and long rectangular plate.

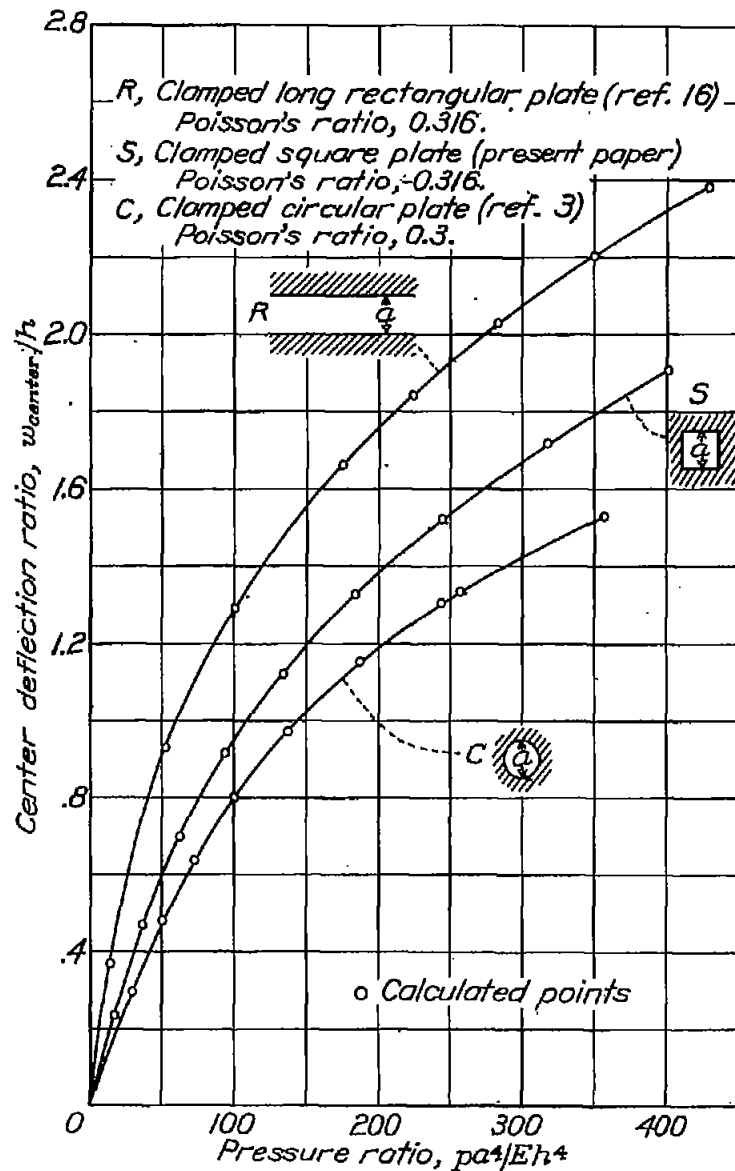

Figure 8.- Variation of deflection at center with pressure for square plate, circular plate, and long rectangular plate.