

NACA TN 4199

NATIONAL ADVISORY COMMITTEE FOR AERONAUTICS

TECHNICAL NOTE 4199

A FLIGHT INVESTIGATION OF THE EFFECTS OF VARIED LATERAL
DAMPING ON THE EFFECTIVENESS OF A FIGHTER
AIRPLANE AS A GUN PLATFORM

By Helmut A. Kuehnel, Arnold R. Beckhardt,
and Robert A. Champine

Langley Aeronautical Laboratory
Langley Field, Va.



Washington
January 1958



TECHNICAL NOTE 4199

A FLIGHT INVESTIGATION OF THE EFFECTS OF VARIED LATERAL
DAMPING ON THE EFFECTIVENESS OF A FIGHTER
AIRPLANE AS A GUN PLATFORM¹

By Helmut A. Kuehnel, Arnold R. Beckhardt,
and Robert A. Champine

SUMMARY

A flight investigation of the effects of varied lateral damping on the effectiveness of a typical high-speed fighter airplane as a gun platform has been made. The test airplane was equipped with a device for varying the lateral damping and with a gunsight employing both a fixed reticle and a gyro computing reticle. In addition, a brief investigation was made with a fixed telescopic sight. Flights were made at three conditions of damping identified as normal, increased, and decreased damping. The data were separated arbitrarily into two turbulence levels, one called "smooth" for variations of normal acceleration less than $\pm 0.5g$ and the other called "moderately rough" for variations more than $\pm 0.5g$.

Results of simulated strafing runs made in this investigation indicate that the gun-line dispersion could be expected to be decreased about 7 percent by increased lateral damping and to be increased about 85 percent by decreased damping and about 40 percent by rough air of the type encountered. Use of the telescopic sight indicated a 20-percent decrease in gun-line dispersion.

INTRODUCTION

Design trends leading to the increased speed and altitude range of jet-powered fighter airplanes have usually resulted in an adverse effect on the damping of the short-period lateral oscillations. Inasmuch as a reduction in damping would be expected to decrease the effectiveness of the airplane as a gun platform, requirements for satisfactory damping of the lateral oscillation should probably be based in part on considerations of the effect of damping on gun-line error. In the past, however, these requirements have been based on a correlation of pilots'

¹Supersedes recently declassified NACA Research Memorandum L53F08a by Helmut A. Kuehnel, Arnold R. Beckhardt, and Robert A. Champine, 1953.

opinions of the lateral oscillatory characteristics of a number of airplanes in normal flight. Very little information has been obtained on the relation between the oscillatory characteristics and the effectiveness of the airplane as a gun platform. Recently, attempts have been made to establish more accurate criteria for acceptable lateral oscillatory characteristics with some emphasis placed on simulated gunnery runs by making tests on airplanes equipped with automatic-control devices that would allow the oscillatory characteristics to be systematically varied. (See ref. 1.) In the present investigation, equipment to simulate snaking oscillations has been installed in a two-place jet-fighter airplane and an investigation has been made of the effect of varying lateral damping on the effectiveness of the airplane as a gun platform.

One major criterion for the effectiveness of a fighter airplane is the "hit" probability that can be achieved by using a particular fire control and armament system. The main factors influencing the hit probability are the ballistic dispersion of the weapon and ammunition, the aiming errors introduced by the combination of fire-control computer and airplane, and the tracking errors introduced by the pilot. The total of aiming error and tracking error has been investigated and is called herein, for convenience, the gun-line error. An attempt has also been made to determine the effect of pilot incentive on tracking errors by changing his aiming reference by use of a gyro computing gunsight and a telescopic sight in addition to the fixed sight.

Data are presented as time histories of the oscillatory characteristics and of gun-line error during simulated strafing runs on a fixed target. Results are presented as gun-line-error distribution and standard deviation of the error. A summary of the error-distribution plots is presented to show the variation of gun-line error with lateral damping. In addition, the oscillatory characteristics of the airplane have been compared to the present service requirements for dynamic lateral-directional stability.

APPARATUS

Test Airplane

The airplane used in this investigation was a two-place jet-fighter trainer airplane. A three-view drawing is presented in figure 1 and a photograph is shown in figure 2. The basic dimensions of the test airplane are given in table I.

Variable Damping Control

Variable damping in yaw was obtained by a flap-type control surface fitted to a fixed fin called a nose fin located a distance forward of the airplane center of gravity about the same as the airplane vertical tail length. The nose-fin area was about 7.3 percent of the vertical-tail area. The flap on the nose fin was aerodynamically balanced and was directly linked to a rate gyro. Restraint on the gyro was supplied only by aerodynamic hinge moments on the flap. A sketch of the rate gyro linkage to the nose flap is presented in figure 3 and the physical characteristics of the nose-fin and gyro installation are given in table II.

The damping of the airplane was changed by reversing the direction of rotation of the nose-flap gyro. Normal damping was the condition with the gyro inoperative and the flap freely floating except for the friction and inertia of the flap linkage and the gyro. Increased damping was obtained by rotating the rate gyro so that the flap deflects to the right in response to right yawing velocity as indicated by the arrows on figure 3. Decreased damping was obtained by reversing the rotation so that the flap deflects to the left in response to right yawing velocity.

The frictional dead spot measured in terms of yawing velocity was 0.001 radian per second. This is the minimum value of yawing velocity necessary to produce enough gyro precession torque to overcome the friction in the gyro and linkage.

Gunsight

Throughout most of this investigation a K-14B gunsight was used. This sight is a reflecting-type gyro computing sight which also incorporates a fixed or noncomputing sight. Detailed operation of the gunsight is described in reference 2. Several runs were also made with a fixed telescopic sight consisting of a modified fixed reticle and a $2\frac{1}{2}$ -power telescope mounted in front of the gunsight combining glass to magnify the target. The reticle images as seen by the pilot and used as his aiming reference are shown to relative scale in figure 4, for each of the three gunsights used. A sketch of the gunsight location and telescope mounting is presented in figure 5.

The computing sight and telescopic sight were used in addition to the fixed sight in order to determine the effect of pilot's perception of tracking error and incentive to apply corrective action on aiming accuracy.

Instrumentation

Standard NACA recording instruments were used to record the following quantities: elevator, rudder, and aileron position; control forces; nose-flap position; nose-flap hinge moment; sideslip angle; change in airplane heading; pressure altitude; indicated airspeed; rolling velocity; yawing velocity; and normal, transverse, and longitudinal acceleration. All measurements of airplane motion are relative to body axes; rudder and elevator deflections are referred to the vertical fin and stabilizer, respectively. Accelerations were measured at a point 2 feet forward of the airplane center of gravity. The recording sideslip vane and pitot tube were mounted on a nose boom approximately 1 maximum fuselage diameter ahead of the nose. Airspeed as used in this report is indicated airspeed. Corrections for instrument location and position error were small and therefore were not applied to the data. During the flight-test program three gun cameras were used. One was mounted within the wall of the right air intake, another in the nose of the airplane, and the horizontal angles of view were 7.2° and 3.6° , respectively. The third camera was used for a limited number of flights to photograph through the gunsight in order to record both reticle image and target position simultaneously. All cameras used 16 millimeter film and had a film speed of 16 frames per second.

All instruments were synchronized by a timing circuit which marked time on the recording film at intervals of 0.1 second. The record switch was under the control of the pilot. The gun camera was controlled independently of the other instruments by a button on the pilot's control stick and was synchronized with the internal instruments by a timing circuit which continually recorded gun-camera frames on the record film during the time that the gun camera was taking pictures.

FLIGHT TESTS

The results of this investigation are based on a series of 87 runs consisting of 41 oscillatory runs and 46 strafing runs, the majority of which were made by one pilot. The runs were made with increased damping, normal damping, and decreased damping. The oscillatory runs were initiated by the pilot's abruptly deflecting the rudder and returning it to neutral at altitudes of 30,000 and 10,000 feet and at indicated airspeeds of 200 to 460 miles per hour. With normal and increased damping the oscillation was allowed to damp with controls fixed. With decreased damping the oscillation was unstable at small amplitudes and was allowed to build up to essentially a constant-amplitude oscillation with controls fixed. After several cycles of this constant-amplitude oscillation, the pilot applied corrective control to damp the oscillation. Strafing runs were made in a shallow dive starting at an altitude of about 5,000 feet

at an indicated airspeed of 350 miles per hour. Gun-camera records were started after the flight path had been established at an altitude of about 3,000 feet, an airspeed of 450 miles per hour, and a range of 5,000 yards. The records were taken continuously until the pull-out at about 400-foot altitude, 550-mile-per-hour airspeed, and 700-yard range. Strafing runs were made with the fixed sight, the gyro computing sight, and a fixed telescopic sight.

DATA REDUCTION

Gun-camera-film data were evaluated by projecting the film onto a screen graduated into 0.05° divisions and measuring the horizontal deviation of the gun-line position from the target position in each gun-camera film frame. The gun-line position in the film frame was determined by boresighting the gun camera. The number of horizontal deviation readings that fell within each angular increment of 0.05° were added and the resulting summations tabulated as horizontal distribution of the gun line. More exactly, the number of readings that fell within $\pm 0.025^\circ$ from the target line were tabulated at the target line or zero displacement. Similarly, the number of readings that fell within the increment from 0.025° to 0.075° displacement from the target line were tabulated at 0.05° displacement. This process was continued on both sides of the target line. Data from all the runs in the same condition were included in this tabulation of horizontal distribution of the gun line. The standard deviation of the gun-line readings was determined as the root-mean-square value of the readings from the target line. (See ref. 3.)

The data from all the strafing runs were arbitrarily separated into two atmospheric turbulence levels. In all runs where the normal acceleration varied less than $\pm 0.5g$ the air was called smooth, and in all runs where it varied more than $\pm 0.5g$ it was called moderately rough for the purposes of this paper.

RESULTS AND DISCUSSION

Lateral Oscillatory Characteristics of the Test Airplane

Typical time histories of the airplane motion showing the oscillations following an abrupt rudder kick are presented in figures 6(a), (b), and (c) for the same altitude and airspeed. The test airplane exhibited positive damping both with normal and increased damping throughout the range of yawing velocity encountered in flight (figs. 6(a) and (b)).

With normal damping the lateral oscillations required about $1\frac{1}{2}$ cycles to damp to half amplitude and with increased damping, only about $1/2$ cycle. The oscillatory characteristics with decreased damping are shown in figure 6(c). The oscillation diverged until it reached an amplitude of about $\pm 3^\circ$ of sideslip angle and then became an essentially constant-amplitude oscillation. During the initial divergence, the amplitude of the oscillation doubled in about $1\frac{1}{2}$ cycles.

The effect of the nose flap movement on the lateral oscillations is evident from figure 6. In figure 6(a) the nose flap is essentially freely floating and has no apparent effect upon the oscillation; however, in figure 6(b) where the nose flap is acting as a yaw damper it is seen to oscillate between its stops due to a large initial yawing velocity and decrease in amplitude as the lateral oscillation is damped. In figure 6(c) where the nose flap is connected to decrease the damping, the nose flap is seen to respond readily to a small initial yawing velocity and cause the oscillation to diverge. The amplitude of the resulting neutral oscillation was limited as a result of the mechanical restraint on the nose-flap travel as indicated by the flattened peaks on the flap-deflection trace. The oscillations resemble those of snaking sometimes exhibited by airplanes at transonic speeds. The pilot had little difficulty in damping the oscillation by application of corrective rudder, as indicated in figure 6(c).

A comparison of the lateral damping characteristics of the test airplane as obtained from several oscillatory runs similar to those of figure 6 with normal and increased damping is presented in figure 7. Superimposed upon this figure are the lateral-directional oscillatory requirements as specified by the Bureau of Aeronautics (ref. 4). The effectiveness of the nose flap as a yaw damper is apparent from this figure. The curve of time to damp to half amplitude as a function of period within an amplitude range of $\pm 2^\circ$ to $\pm 0.1^\circ$ of sideslip angle was shifted well within the satisfactory range as specified in reference 4. The period was varied by changing the airspeed.

Effect of Damping of the Lateral

Oscillation on Gun-Line Error

Typical time histories of the airplane motion and control deflections with corresponding variation in horizontal deviation of the gun line are presented in figures 8(a), (b), and (c). These time histories were obtained at three conditions of damping in yaw during smooth-air runs with the fixed gunsight. The figures indicate a slightly beneficial

effect of increased damping and a large adverse effect of decreased damping on the effectiveness of the airplane as a gun platform.

Horizontal distribution of the gun line.- Figure 9 is a summary plot of the percentage of total run time that the gun line was held within angular increments of 0.05° as a function of the angular deviation from the target (gun-line error). It is expected that the gun-line distribution would approach a normal distribution pattern (ref. 3) provided enough runs had been made. This trend is indicated for the distribution curve of figure 9(a) for increased damping where 11 runs were averaged. The standard deviation of the gun-line distribution was determined and used as a measure of the dispersion. Values of standard deviation are noted in the figure and summarized in table III.

Figure 9(a) presents results of a strafing run at a fixed target by using a fixed-reticle sight in smooth air. Decreased damping resulted in about an 85-percent increase in dispersion over that for the normal damping and increased damping decreased the dispersion only 7 percent. Essentially the same results were obtained for the case presented in figure 9(b), where the runs were made in moderately rough air. However, the advantage to be gained by increased damping is even less pronounced in turbulent air. Comparison of figures 9(a) and 9(b) indicates that rough air has a very pronounced effect on gun-line error. An increase in dispersion of about 40 percent may be expected from rough air of the type encountered.

Figures 9(c) and 9(d) present the dispersion of the gun line when a computing sight is used in performing simulated strafing runs. No data are available for increased damping with the computing sight. Then, too, the data available for normal and decreased damping with the computing sight are sparse and should be viewed with caution. The data show, however, that about a 6-percent increase in dispersion may be expected by use of the computing sight instead of the fixed sight.

Effect of computing sight on pilot's incentive to apply corrective control.- The increase in gun-line dispersion when the computing gun-sight is used may be largely attributed to its smoothing action and resulting effect on pilot incentive. The effect of this smoothing action, caused by lag of the sight reticle behind the airplane motion, may be explained in connection with figure 10. Time histories of the gun-line deviation from the target and the computing-sight reticle motion during a portion of a strafing run are presented in figure 10(a) and the corresponding sighting error is superimposed on the gun-line deviation in figure 10(b). The sighting error is the reticle-image displacement from the gun-line position in figure 10(a) and is the pilot's only reference for corrective action. From figure 10(b), it is seen that the sighting error is small in comparison with the gun-line error (deviation from the target). The pilot is therefore supplied with a false impression of

good aiming accuracy which decreases his incentive to apply corrective controls. The pilot's perception of the airplane motion is further reduced by the size of the reticle image which covers the entire target at long range and a sizable portion of it at short range. If the computing-sight reticle image were superimposed on figure 9, it would obscure about 0.035° on each side of zero. Therefore, the pilot's tracking incentive was reduced in this region. The computing sight is, of course, necessary to provide the correct lead angle when firing at a rapidly moving target.

Effect of damping on total on-target time.- Figure 11 illustrates the effect of lateral damping on total percentage of time that the gun line is within set increments of deviation of $\pm 0.1^\circ$, $\pm 0.2^\circ$, $\pm 0.3^\circ$, $\pm 0.4^\circ$, and $\pm 0.5^\circ$. The figure shows that increased damping is advantageous when the pilot is strafing a small target or is at such range as to limit his horizontal deviation to about $\pm 0.1^\circ$ in order to achieve hits. As the target size is increased or the range is shortened, so as to permit a greater scatter of gun fire without decreasing the hit concentration, the advantage of increased damping is diminished. Reference to figure 11 indicates that if the target is of such size or at such range as to allow a horizontal deviation of $\pm 0.4^\circ$ or $\pm 0.5^\circ$ to achieve hits, then the increased damping would have no significant effect on increasing the gunfire effectiveness. However, the pilot felt that he could do a better job of strafing under all conditions with the increased damping.

Effect of Increased Pilot Perception of Tracking Error

Six additional runs were made with the fixed telescopic sight to determine what effect an improvement in the pilot's perception of his tracking error would have on aiming accuracy. These runs were made in moderately rough air with both normal and increasing damping. The purpose of the modified reticle was to alleviate the difficulty of obscuring the target as was experienced with the original reticle. The telescope allowed easier recognition of the target and magnified the relative motion between airplane and target, so that the tracking error was more apparent to the pilot. The pilot was therefore supplied with the impression of larger deviations than actually occurred and thus was given added incentive for corrective action, a condition opposite to that obtained with the gyro computing gunsight. The major objection to the modified sight was the narrow field of view associated with the telescope. The pilot experienced considerable difficulty when the target was lost from the telescope field and hidden by the telescope lens mounts. For this reason the first two runs of each flight were considered

only as pilot familiarization runs. Standard deviation of the horizontal distribution of the gun line was computed and found to be about 0.16° for normal damping and 0.15° for increased damping. Comparison of these values with those for the unmodified sight in moderately rough air (fig. 9(b)) shows a decrease in dispersion of about 20 percent for the modified telescopic sight. However, it is believed that these figures are not representative of the improved accuracy possible with the modified sight. They were obtained from the entire record which included the time that the target was entirely lost from the field of view and the pilot had no aiming reference whatsoever. The field of view varied between about $\pm 0.9^\circ$ to $\pm 1.3^\circ$, when the pilot's eye was centered on the telescope, depending upon how close the pilot's eye was to the lens. The field of view was effectively decreased below these values, however, due to random movements of the pilot. For this reason it was not possible to separate the data into time when the target was within the telescope field and when it was lost from the field of view.

Yaw-Damper Requirements

Time histories of strafing runs presented in figure 8 indicate that the amplitude of the horizontal deviation with both normal and increased damping is seldom greater than $\pm 0.3^\circ$. With decreased damping, the horizontal deviations were initially of considerably greater amplitude. However, the pilot was able to keep the deviations within an amplitude of about $\pm 0.5^\circ$ without excessive difficulty. Therefore, it appears that a yaw damper need only respond to small yawing velocities and be effective in damping corresponding small amplitudes. The lower limit of response of the yaw damper as determined by its frictional dead spot should be low so that the yaw damper will be effective during strafing since only small yawing velocities are encountered. The yaw damper used in this investigation had a frictional dead spot of about 0.001-radian-per-second yawing velocity and was very effective in damping small-amplitude oscillations. Another factor to be considered is that the yaw damper should not increase control forces appreciably during normal maneuvers.

CONCLUSIONS

From the results of a flight investigation with a typical high-speed fighter trainer-type airplane fitted with equipment for varying the lateral damping, the following conclusions have been drawn:

1. The standard deviation of the lateral gun-line error for the airplane performing strafing runs in calm air with normal damping is about 0.14° . Approximately 7-percent decrease in dispersion was realized

by increased damping. Rough air of the type encountered increased the dispersion about 40 percent, and decreased lateral damping increased the dispersion about 85 percent.

2. When strafing a fixed target, better accuracy can be achieved by using a fixed sight than a computing sight. In general, use of the computing sight increased the lateral dispersion about 6 percent. This result can be explained by the smoothing action of the computing sight, which supplies the pilot with a misleading conception of good aiming accuracy.

3. The gunsight-reticle image covered a considerable portion of the target and consequently reduced the pilot's incentive for corrective action during small-amplitude oscillations at long range or when strafing a small target. The open-center-reticle image used in the fixed sight in conjunction with a $2\frac{1}{2}$ -power telescope appeared to alleviate this difficulty and reduced the lateral dispersion about 20 percent of the value for the fixed sight, in spite of an adverse effect of this arrangement on the pilot's field of view.

4. The small deviations encountered during strafing runs indicate that a yaw damper must have a small frictional dead spot of not more than 0.001-radian-per-second yawing velocity in order to be effective in damping these oscillations of small amplitude. Furthermore, the yaw damper need not be effective in damping amplitudes greater than $\pm 0.5^\circ$ of yaw since the pilot is capable of damping oscillations of large amplitude.

Langley Aeronautical Laboratory,
National Advisory Committee for Aeronautics,
Langley Field, Va., May 27, 1953.

REFERENCES

1. Liddell, Charles J., Jr., Creer, Brent Y., and Van Dyke, Rudolph D., Jr.: A Flight Study of Requirements for Satisfactory Lateral Oscillatory Characteristics of Fighter Aircraft. NACA RM A51E16, 1951.
2. Anon.: Handbook - Operation, Service, and Overhaul Instructions With Parts Catalog. Computing Gun Sights - USAF Types K-14A, K-14B, K-14C, K-18, and K-18A; Navy Mark 23. AN 11-35C-1, U. S. Air Force and Bur. Aero., June 28, 1948. (Revised Aug. 22, 1950.)
3. Eshbach, Ovid W., ed.: Handbook of Engineering Fundamentals. John Wiley & Sons, Inc., 1936.
4. Anon.: Specification for Flying Qualities of Piloted Airplanes. NAVAER SR-119B, Bur. Aero., June 1, 1948.

TABLE I

BASIC DIMENSIONS OF TEST AIRPLANE

Item	Wing	Vertical tail
Area, sq ft	237	22.40
Span, ft	38.8	6.40
Aspect ratio	6.39	2.48
Taper ratio	0.36	0.40
Mean aerodynamic chord, in.	80.60	-----
Section	NACA 65 ₁ -213	NACA 65-010
Distance from center of gravity to rudder hinge line	-----	16.5

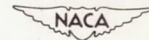

TABLE II

PHYSICAL CHARACTERISTICS OF NOSE-FIN AND GYRO INSTALLATION

Area, sq ft	1.64
Span, ft	1.67
Aspect ratio	2.64
Taper ratio	0.53
Section	NACA 65-010
Distance from airplane's center of gravity to flap hinge line, ft	16.2
Flap travel	19° right 17° left
Gear ratio between gyro and flap	1.0
Moment of inertia about rotor axis, in-lb-sec ²	0.09
Moment of inertia of the gyro about gimbal axis, in-lb-sec ²	0.10
Rotational speed of gyro rotor, rpm	9,400

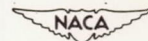
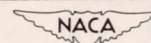

TABLE III

STANDARD DEVIATION OF THE GUN LINE
OBTAINED FROM FLIGHT TEST DATA

Condition of damping	Deviation, deg				
	Fixed sight		Computing sight		Telescopic sight
	Smooth air	Rough air	Smooth air	Rough air	Rough air
Normal	0.14	0.21	0.23	0.19	0.16
Increased	.13	.20	----	----	.15
Decreased	.26	.40	.26	.46	----



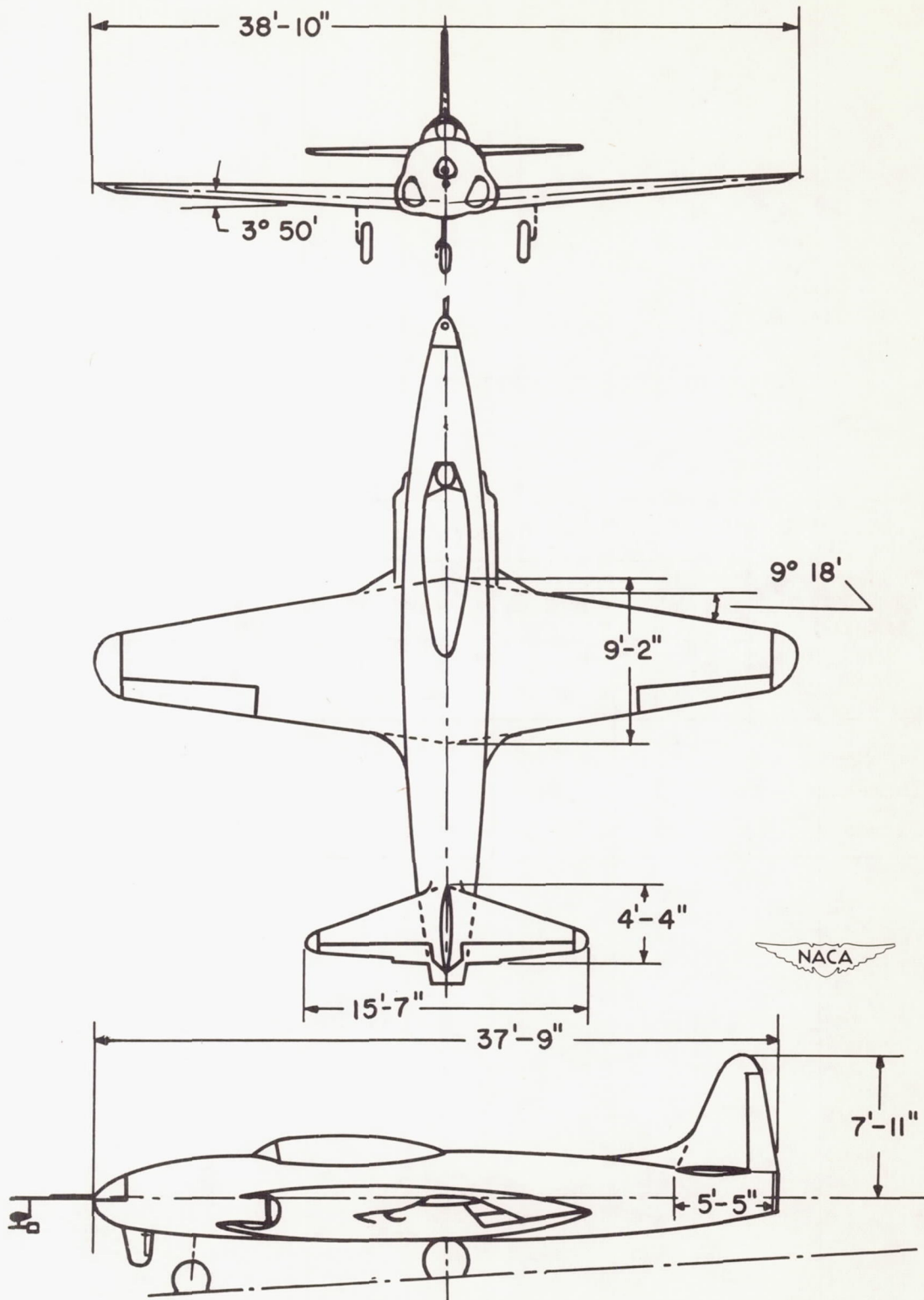

Figure 1.- Three-view drawing of test airplane with basic dimensions.

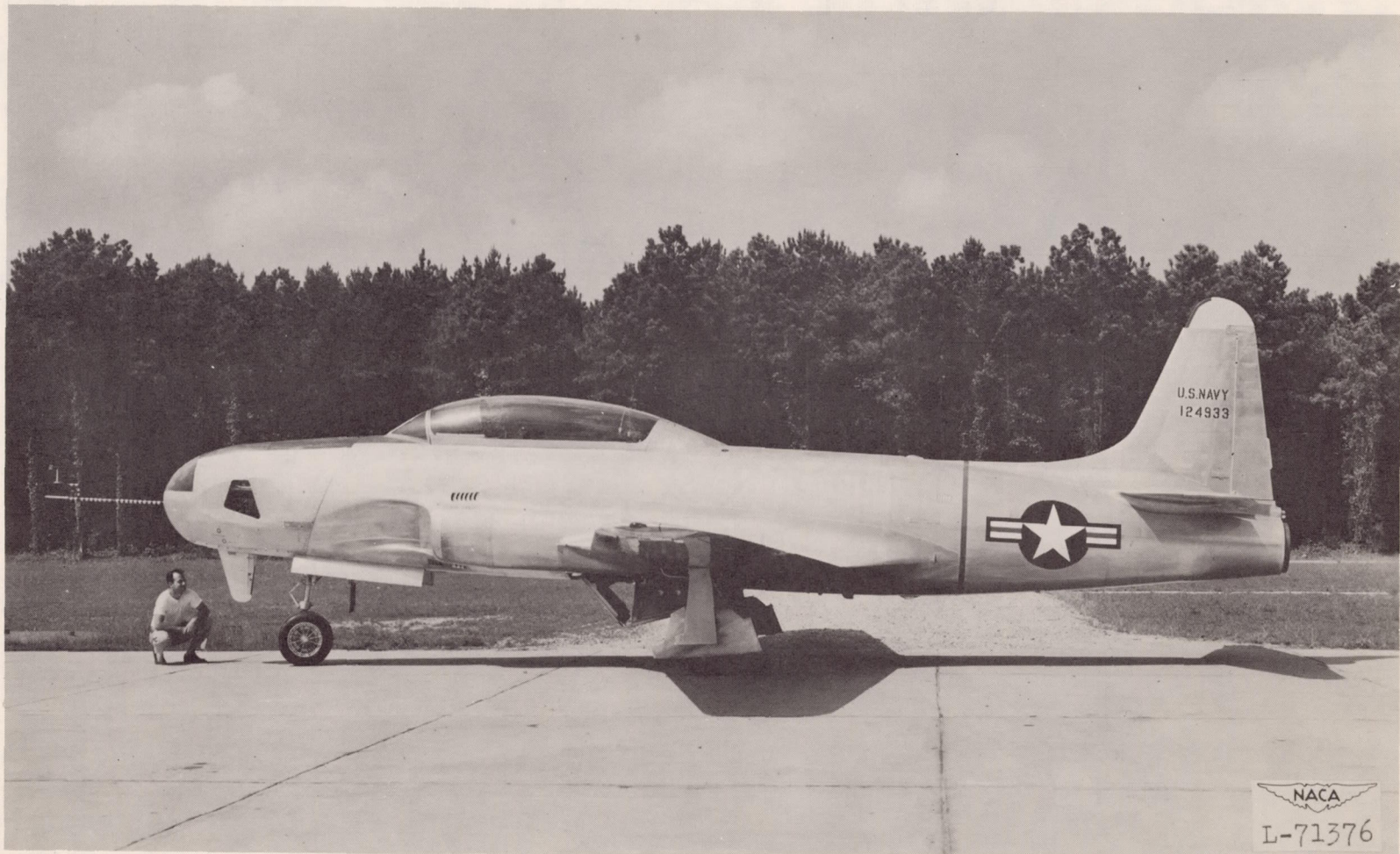

Figure 2.- Photograph of the test airplane.

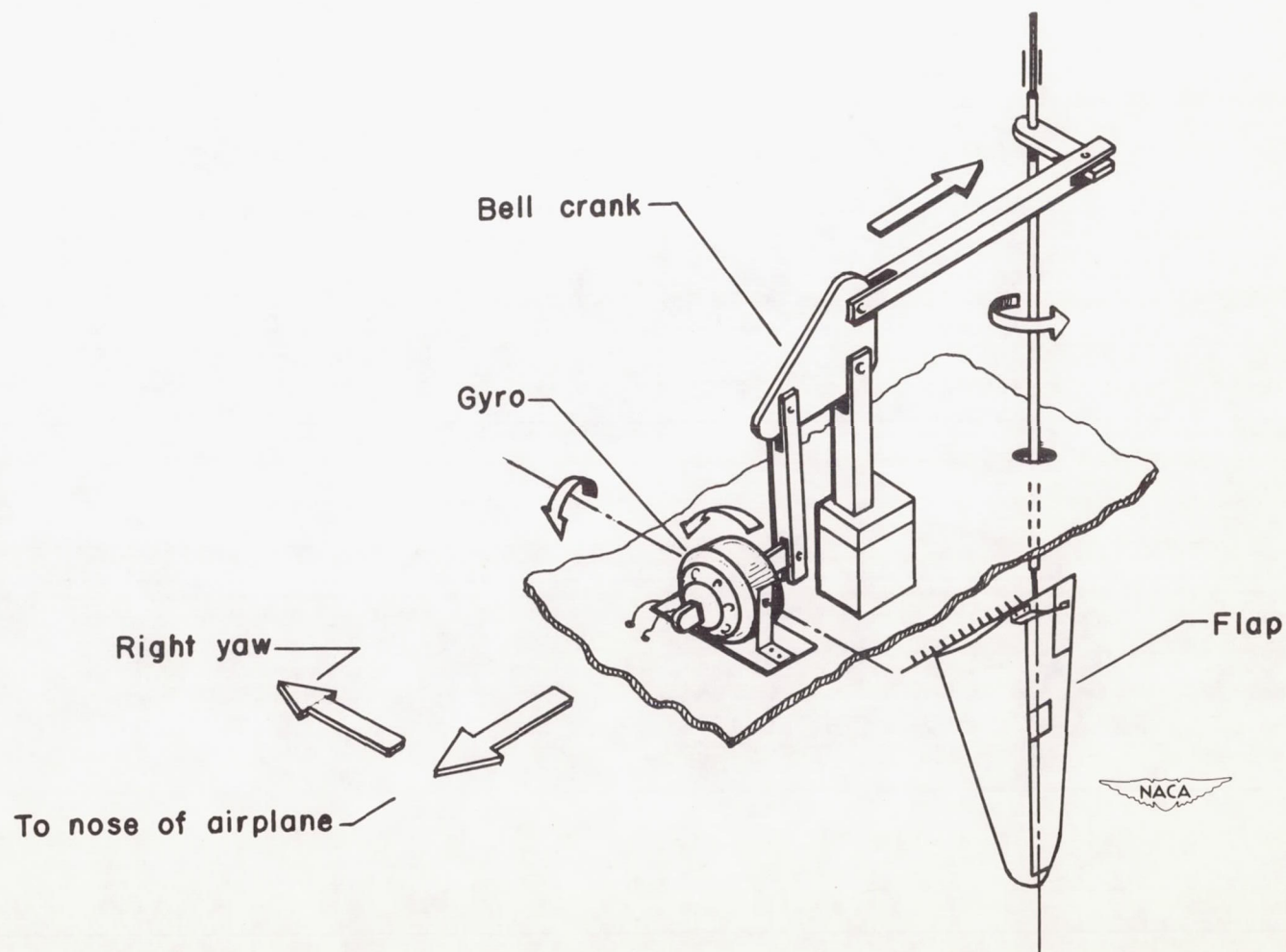
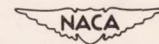
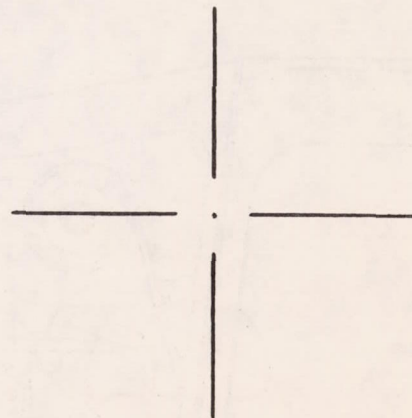

Figure 3.- Sketch of the variable-damping device used in this investigation.
 (Shaded arrows indicate response of system to right yawing velocity when acting as a yaw damper.)



Fixed sight
1.2 mil central cross

Computing sight
1.2 mil central dot

Fixed telescopic sight
1.2 mil open center

Figure 4.- Gunsight reticles used for each of the three sight conditions.
(1 mil = $\frac{1}{6400}$ of 360° or the angle subtended by 1 foot in 1,000 feet.)

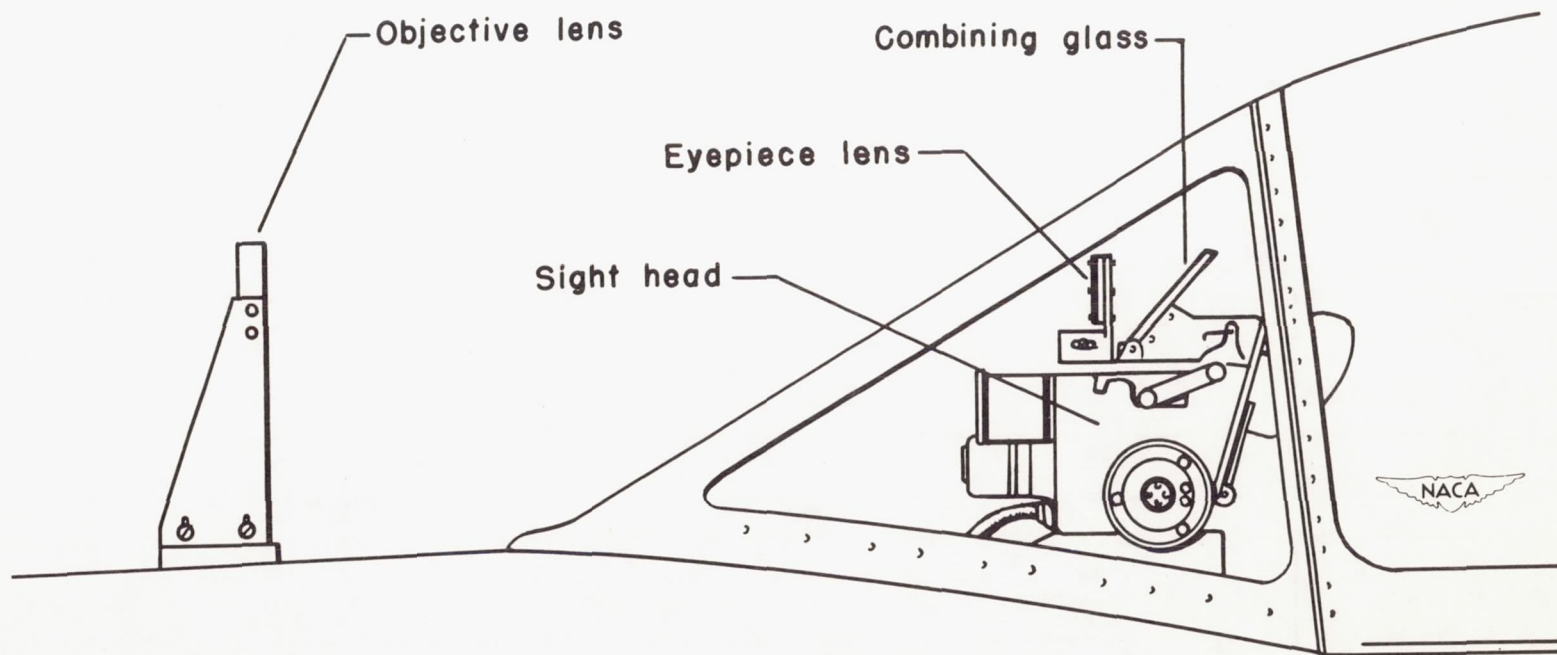

Figure 5.- Sketch of telescopic lens mounting in test airplane.

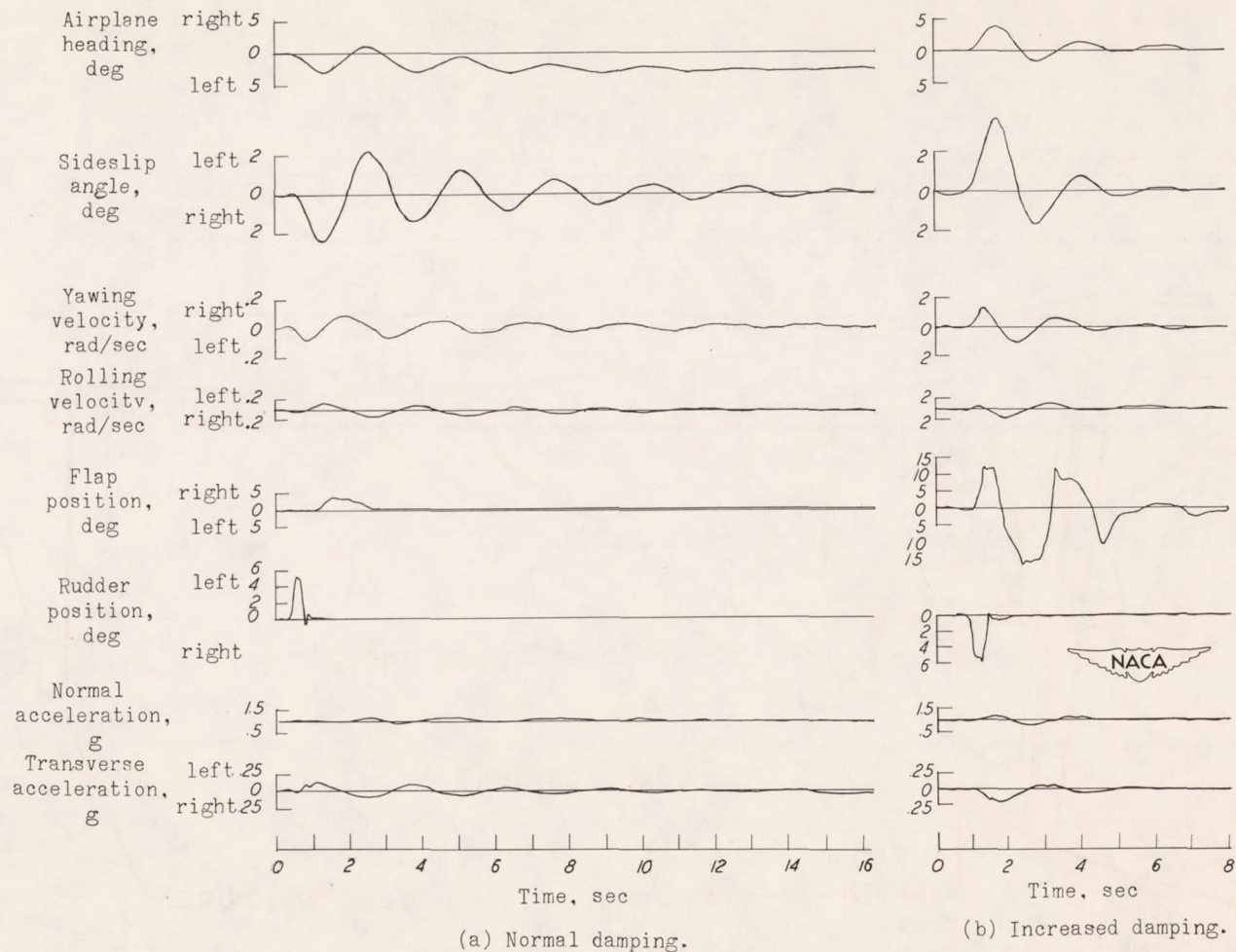
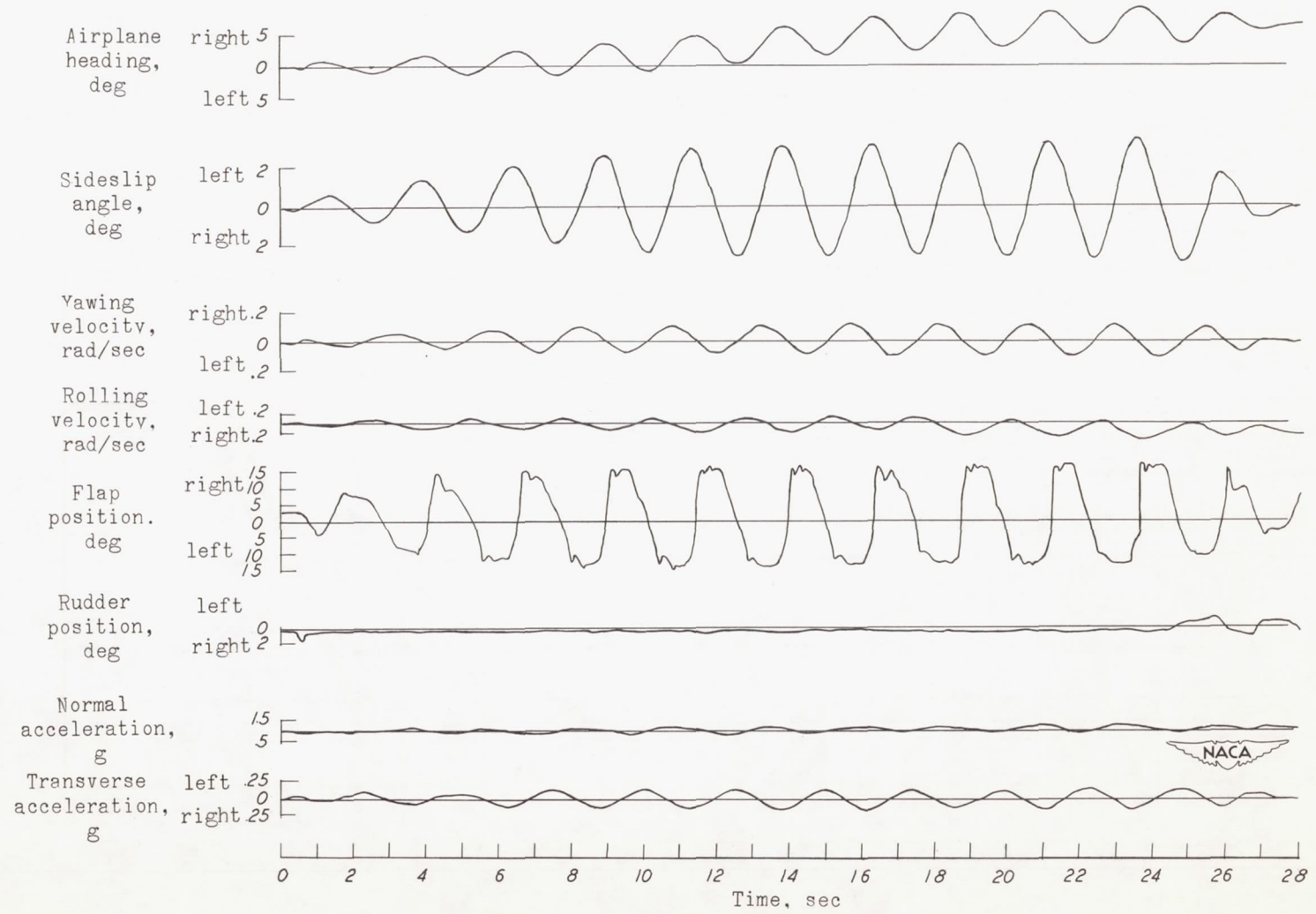

Figure 6.- Typical oscillation time histories of test airplane with normal, increased, and decreased damping following an abrupt rudder kick at an indicated airspeed of about 300 mph and an altitude of 30,000 feet.



(c) Decreased damping.

Figure 6.- Concluded.

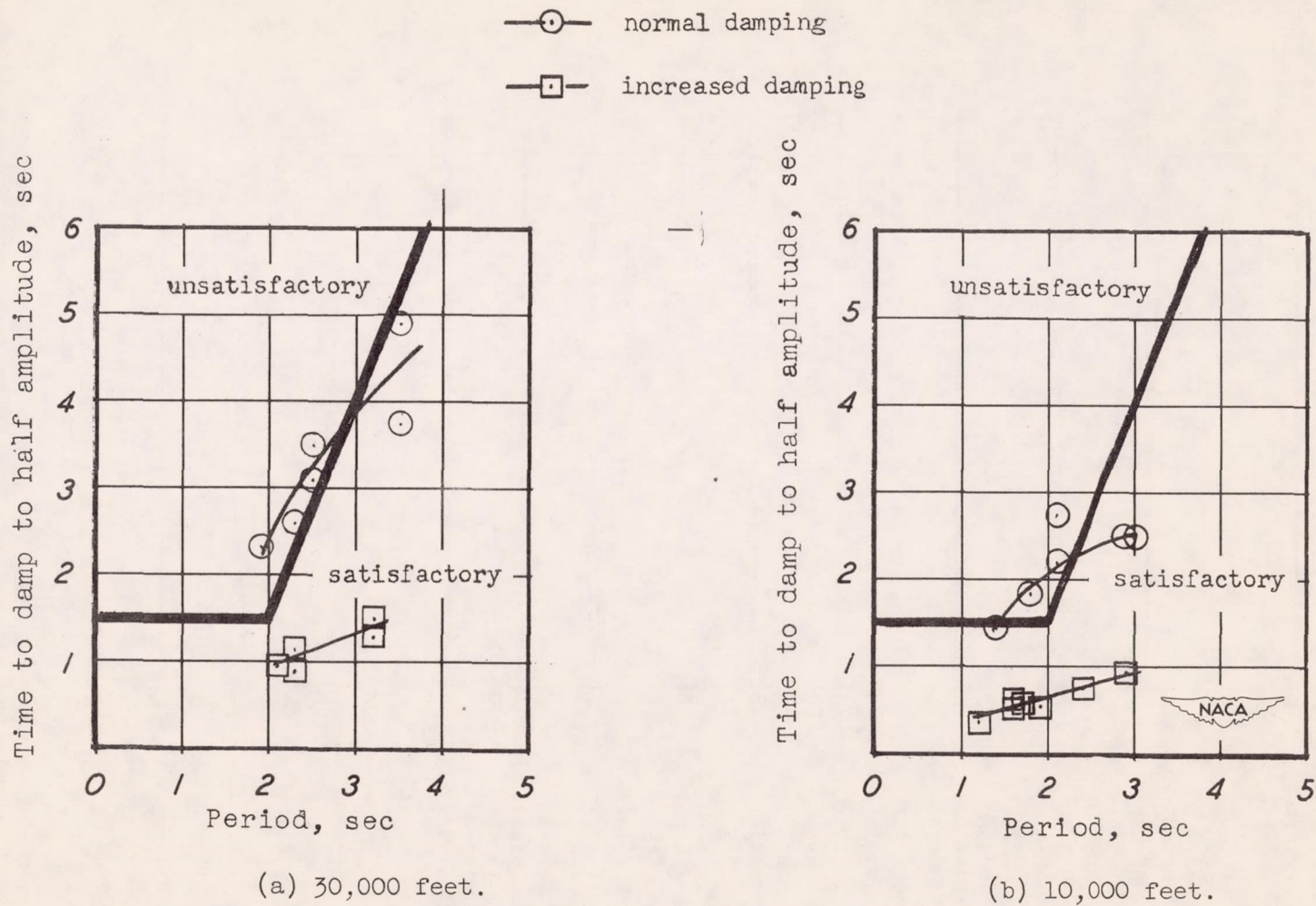

Figure 7.- Comparison of lateral damping of test airplane with normal and increased damping with present service requirements for lateral-directional damping at altitudes of 30,000 and 10,000 feet.

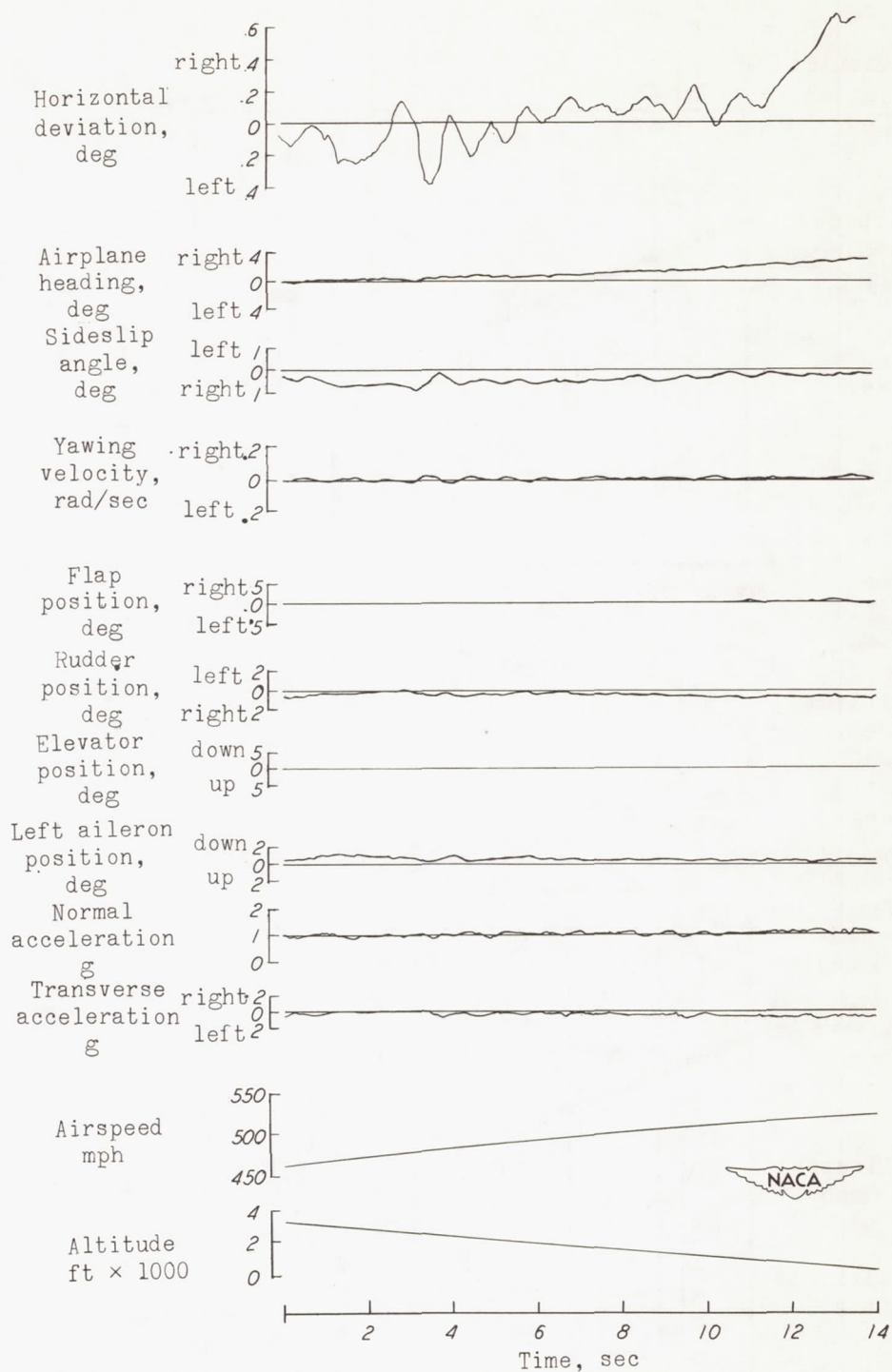
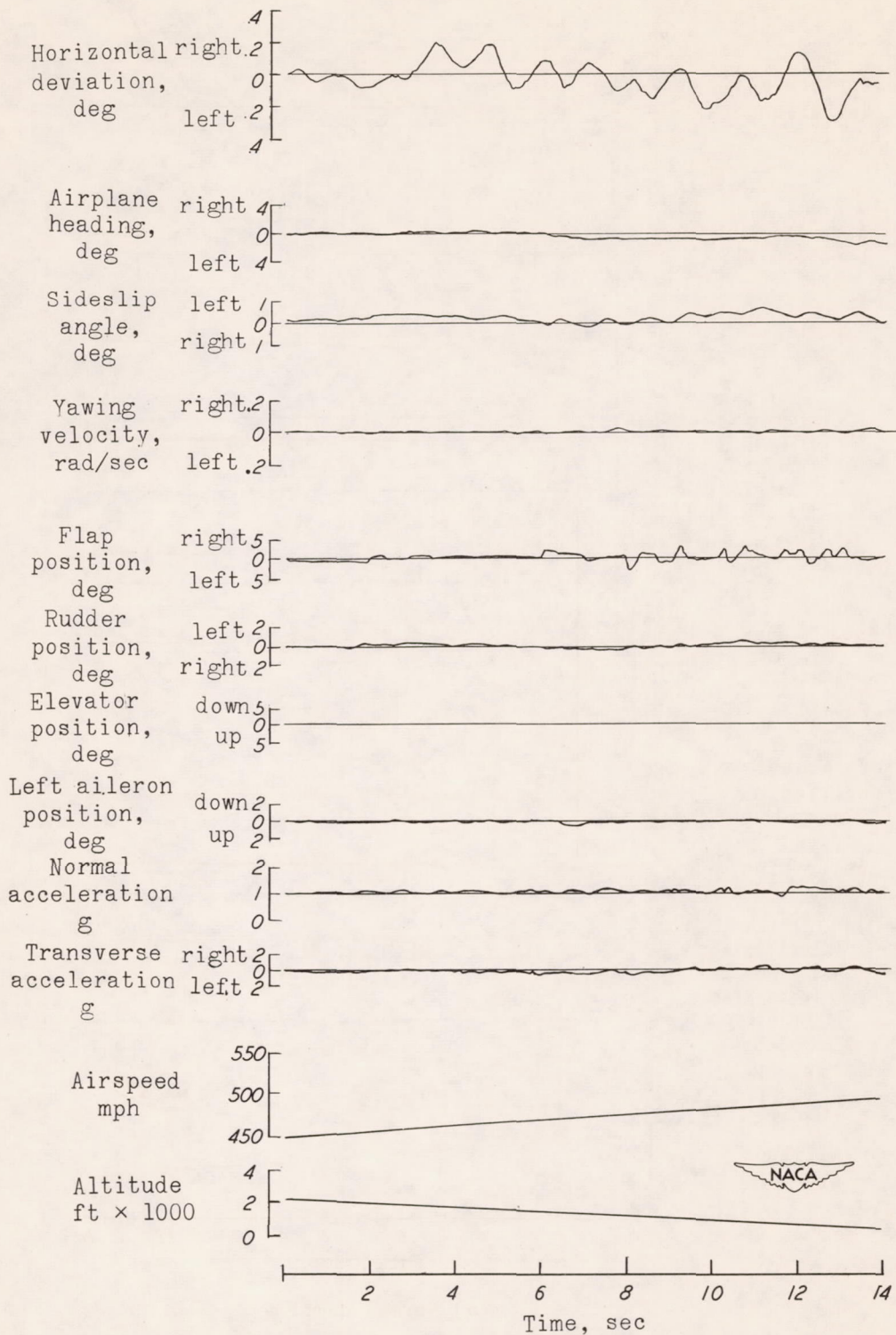
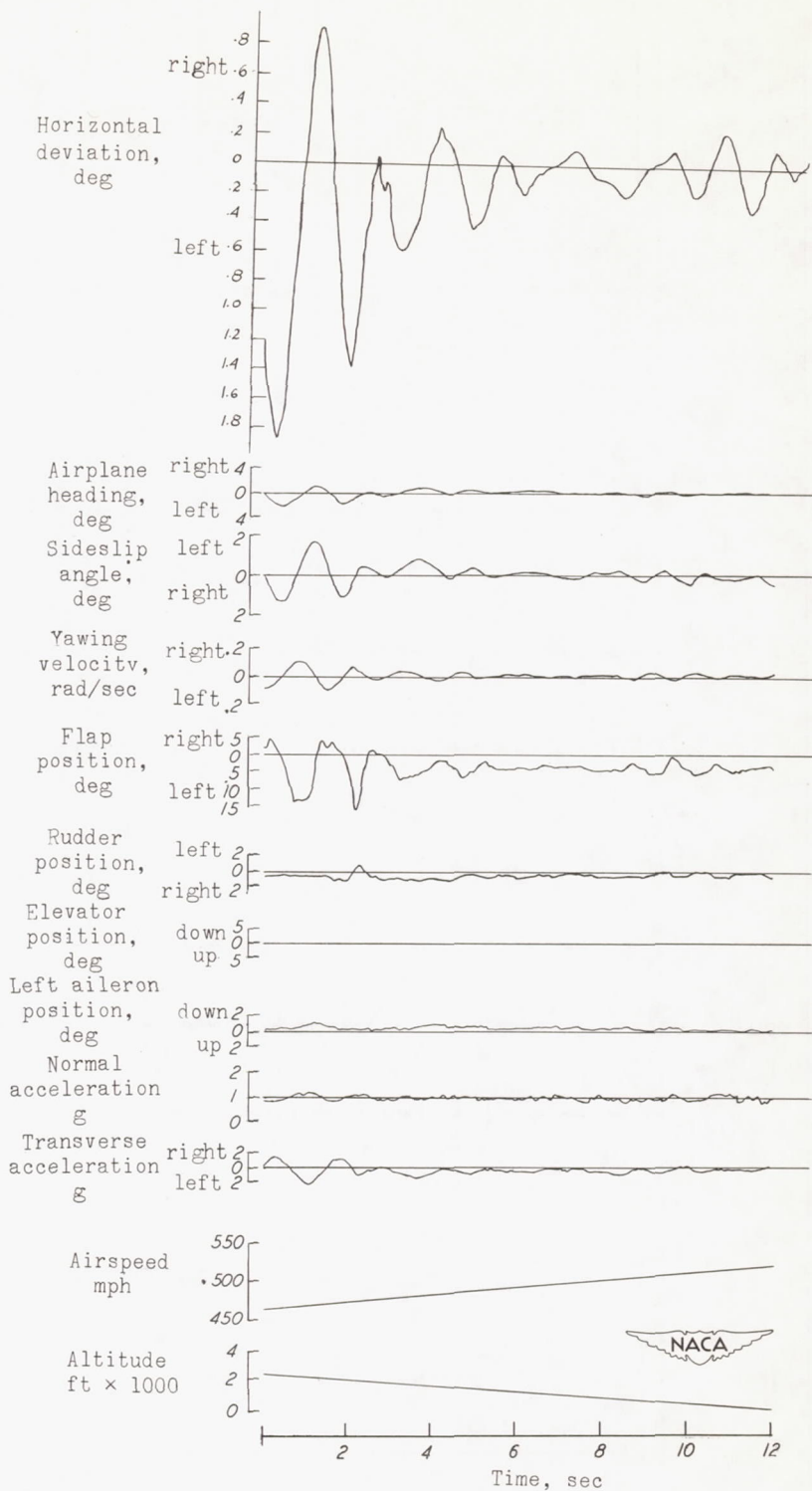

Figure 8.- Typical time histories of strafing runs with three conditions of lateral damping performed in smooth air.



(b) Increased damping.

Figure 8.- Continued.



(c) Decreased damping

Figure 8.- Concluded.

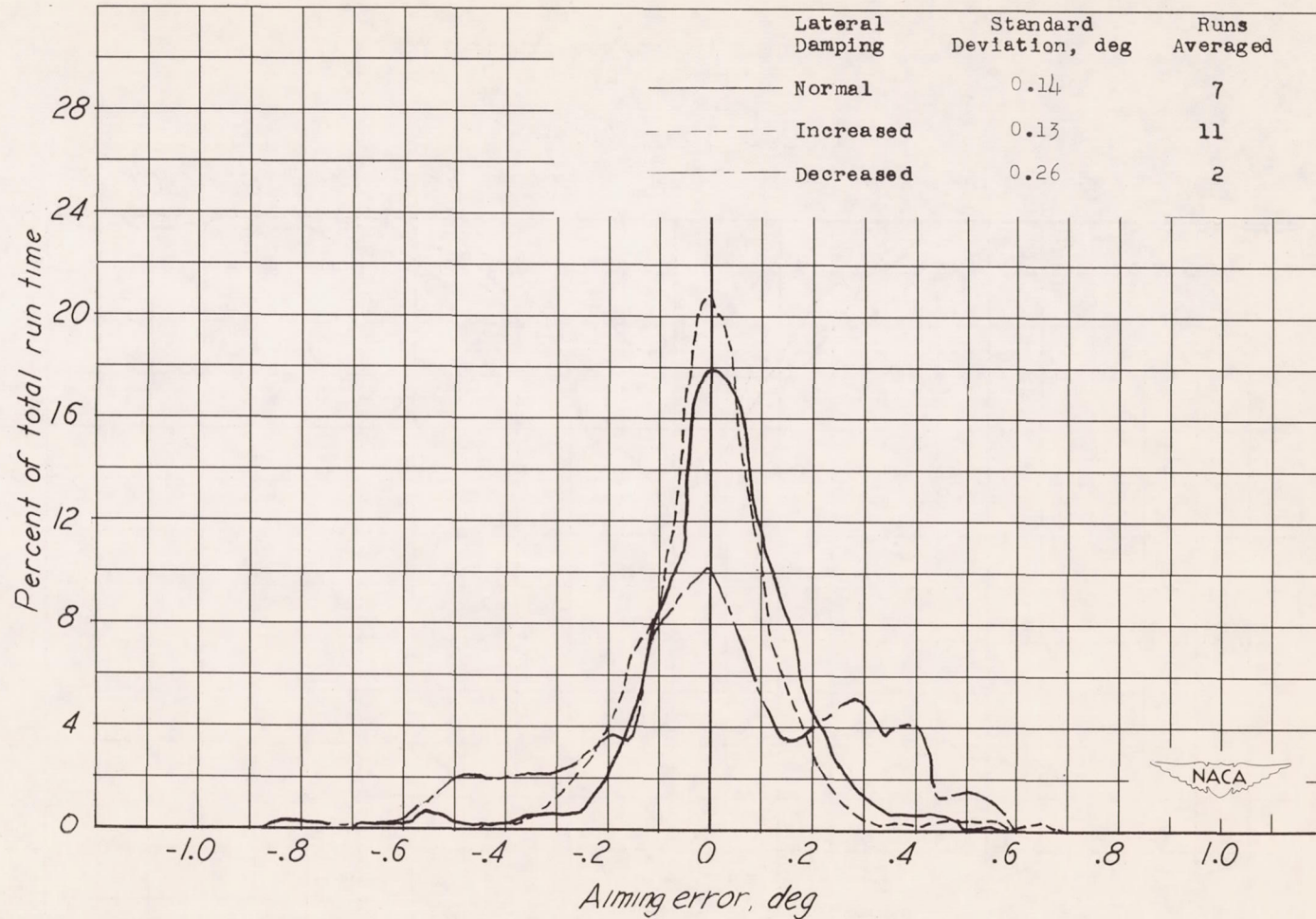

(a) Fixed sight; smooth air.

Figure 9.- Average horizontal distribution of the sight line presented as a function of percent of total run time.

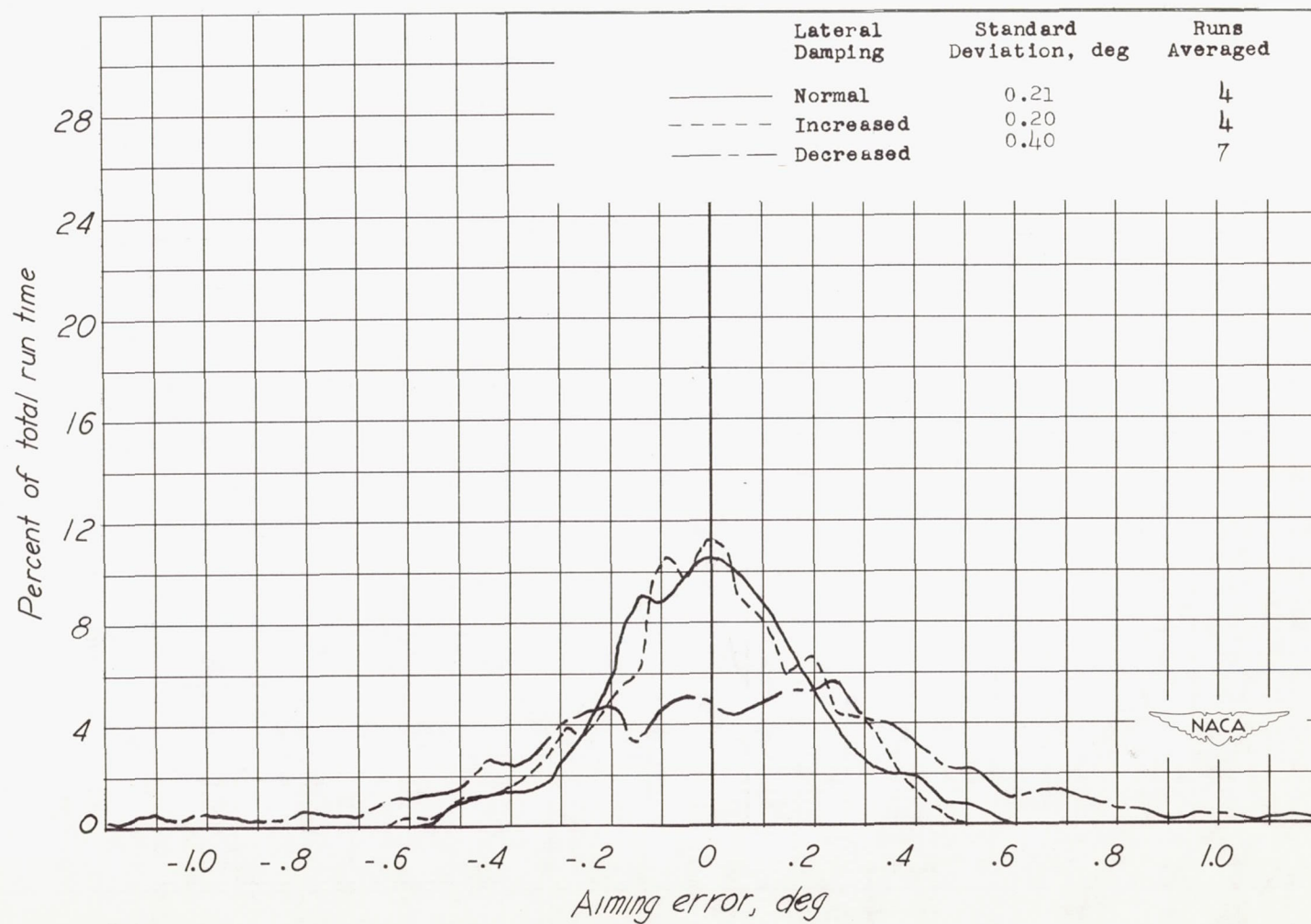

(b) Fixed sight; moderately rough air.

Figure 9.- Continued.

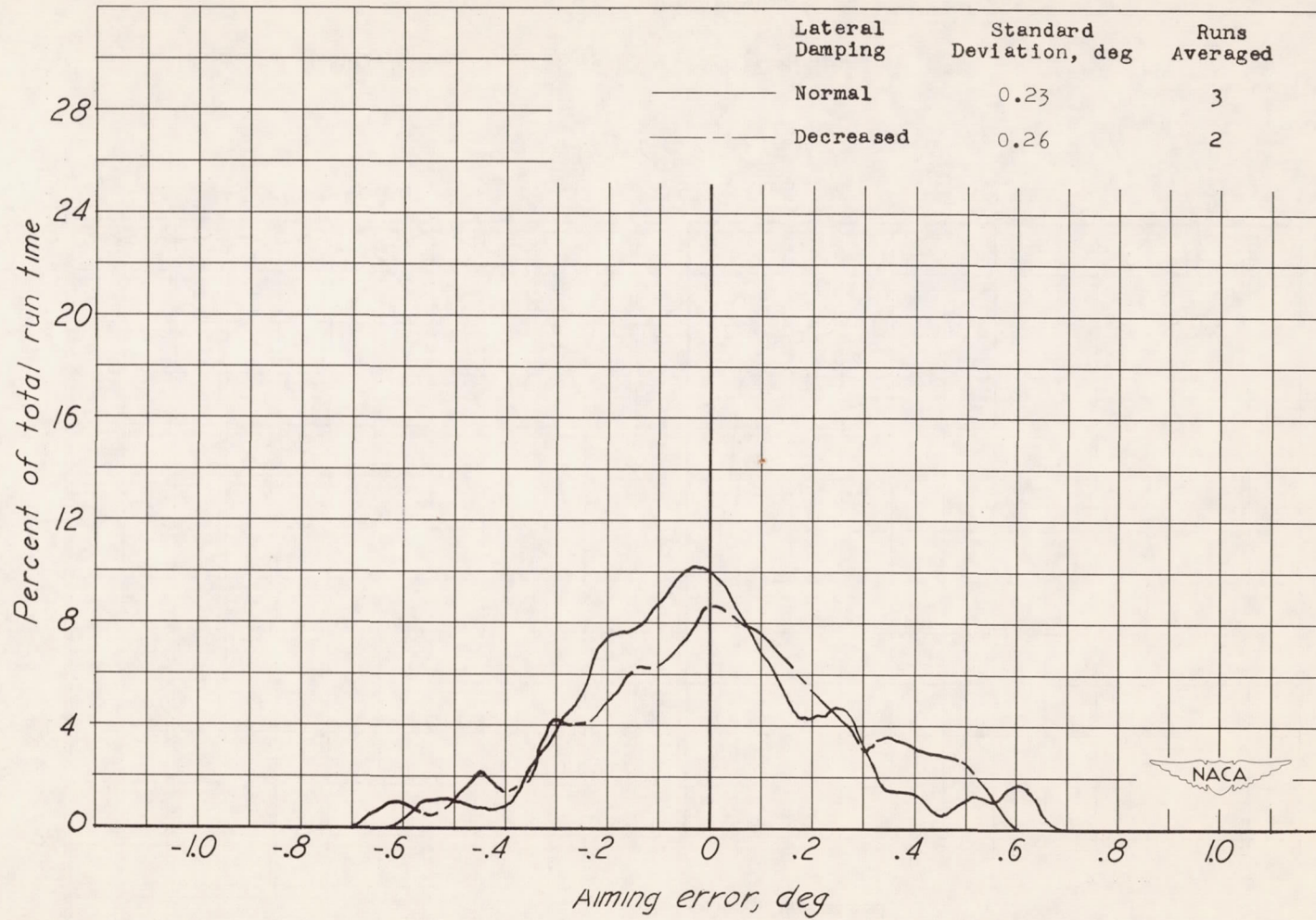

(c) Computing sight; smooth air.

Figure 9.- Continued.

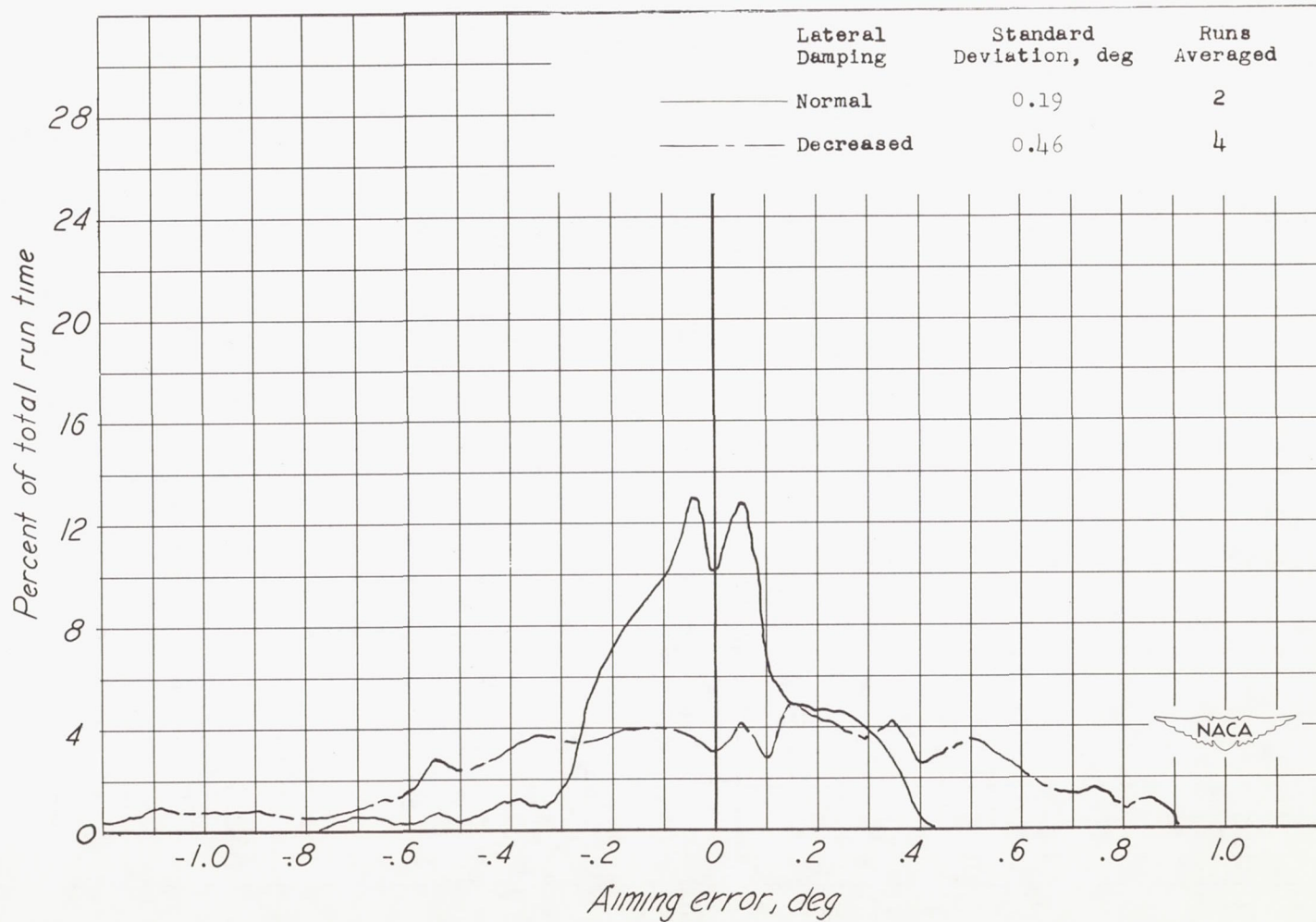

(d) Computing sight; moderately rough air.

Figure 9.- Concluded.

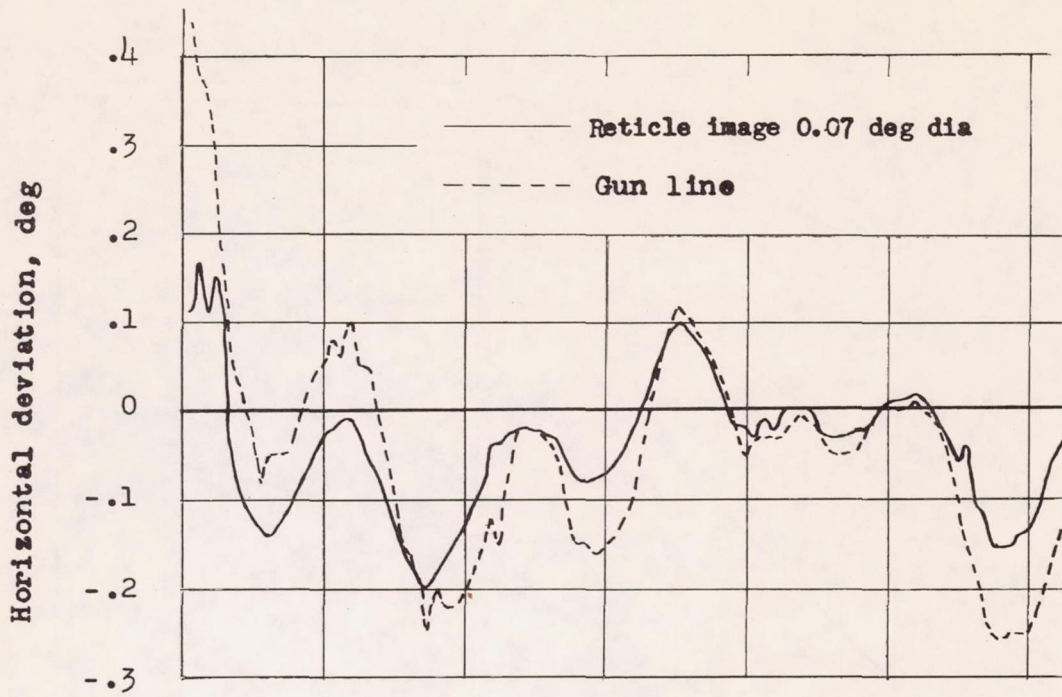

(a)

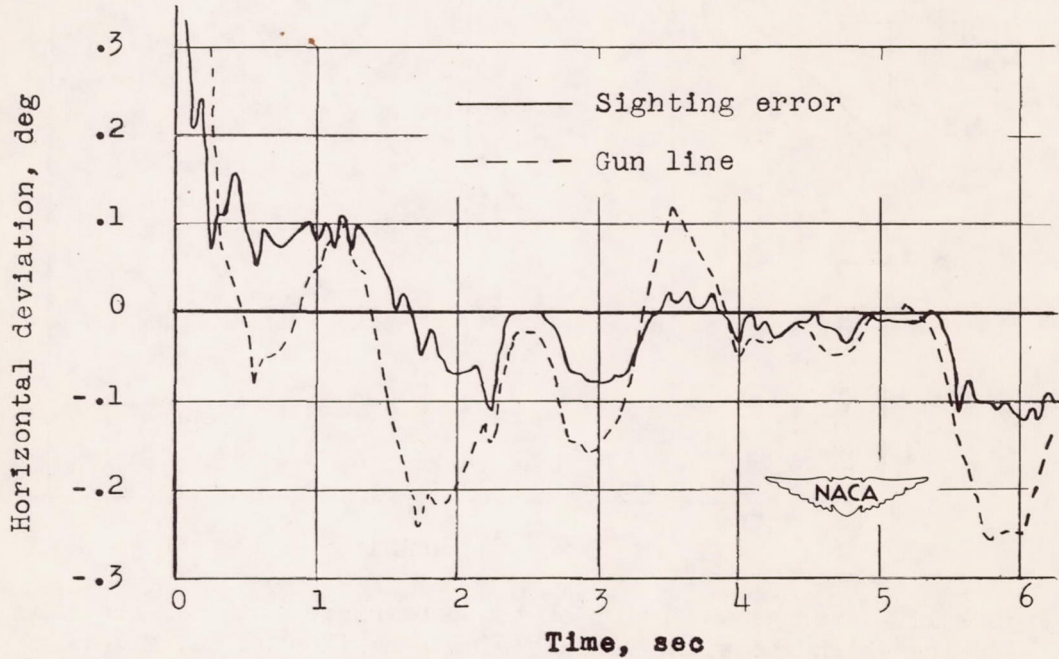

(b)

Figure 10.- Time histories of computing-sight reticle image and gun-line deviation and corresponding sighting error.

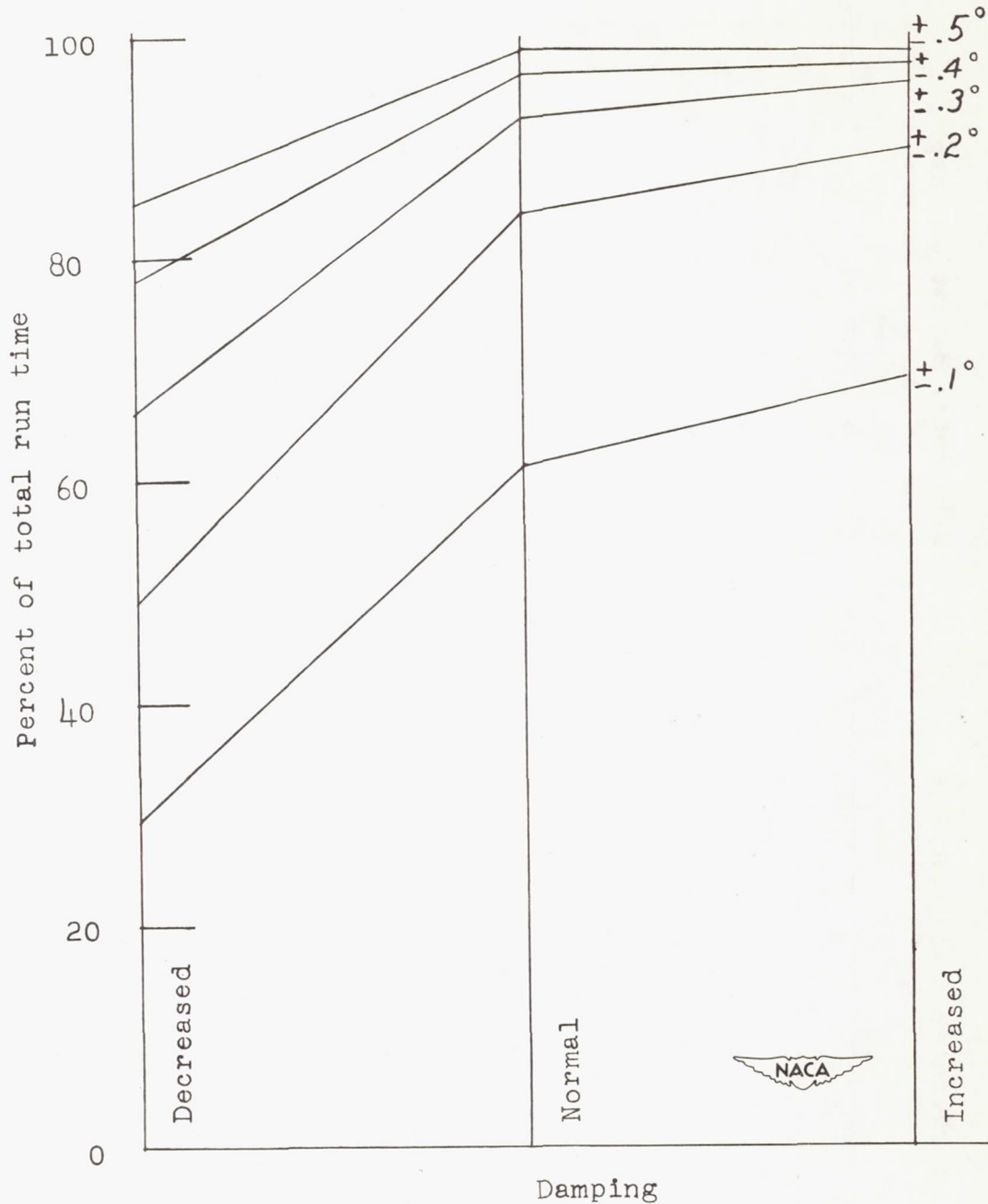

Figure 11.- Average variation of the percentage of total run time during which the sight line is within horizontal increments of $\pm 0.1^\circ$, $\pm 0.2^\circ$, $\pm 0.3^\circ$, $\pm 0.4^\circ$, and $\pm 0.5^\circ$ of the target as the lateral damping is increased during strafing runs made with the fixed sight.