

NACA TN 4298 079

TECH LIBRARY KAFB, NM  
00672216

# NATIONAL ADVISORY COMMITTEE FOR AERONAUTICS

TECHNICAL NOTE 4298

EXPLORATORY WIND-TUNNEL INVESTIGATION TO DETERMINE THE  
LIFT EFFECTS OF BLOWING OVER FLAPS FROM

NACELLES MOUNTED ABOVE THE WING

By John M. Riebe and Edwin E. Davenport

Langley Aeronautical Laboratory  
Langley Field, Va.



Washington

June 1958

TECHNICAL LIBRARY



## TECHNICAL NOTE 4298

EXPLORATORY WIND-TUNNEL INVESTIGATION TO DETERMINE THE  
LIFT EFFECTS OF BLOWING OVER FLAPS FROM  
NACELLES MOUNTED ABOVE THE WING

By John M. Riebe and Edwin E. Davenport

## SUMMARY

An exploratory wind-tunnel investigation has been made to determine the lift effects of blowing from nacelles over the upper surface of flaps on a model having a delta wing of aspect ratio 3. Several flap conditions were examined. High-pressure air was blown from an external-pipe arrangement supported above the wing to simulate jet-engine exhaust. The jet-momentum-coefficient range was from 0 to 3.0 and the model angle of attack was  $0^\circ$ .

The results of this limited investigation show that values of jet-circulation lift coefficient larger than the jet reaction were produced with blowing over flaps from nacelles mounted above the wing. The use of double slotted flaps with the gap unsealed between the flaps and wing had a large detrimental effect on the lift capabilities. With these gaps sealed, larger lift coefficients were obtained when fantails were added to the nacelles. The longitudinal trim problems created by large diving moments were similar to those encountered with other jet-augmented-flap systems.

## INTRODUCTION

Previous investigations have shown that jet-augmented flaps show promise in reducing the take-off and landing distance of jet aircraft. (For example, see refs. 1, 2, and 3.) This work can be divided into two general categories: an external arrangement in which the exhaust air from engines mounted below the wing is directed up through a slot and downward over the upper surface of the flaps, and an internal arrangement in which jet engines are blended with the wing with the air brought in the wing leading edge and exhausted at the trailing edge. An arrangement with blowing over flaps from nacelles mounted on top of or above the wing might

achieve most of the advantages of the multiple-internal-engine arrangement but with a relatively small number of externally mounted engines. Possible advantages of such an arrangement on a high-wing airplane are: noise suppression benefiting both the occupants and the people on the ground, good slow-speed performance, diminution of ground effect, and reduction of trash ingestion by high placement of the engine inlets. The arrangement would be especially suited for seaplanes because it would reduce the spray on the engine inlets and on the flaps.

The present tests, which were undertaken to explore the lift characteristics obtainable with blowing over flaps from nacelles mounted above the wing, were made on an existing research seaplane model with a delta wing of aspect ratio 3. High-pressure air was blown through steel nacelle pipes supported externally above the wing to simulate jet-engine exhaust. For comparative purposes, a few tests were made with the nacelle pipes supported below the wing. The investigation was made in the Langley 300-MPH 7- by 10-foot tunnel with the model mounted on the single strut support.

The tests included blowing over single and double slotted flaps from nacelles mounted above the wing and blowing over double slotted flaps from nacelles mounted below the wing. For some tests with nacelles mounted above the wing the flap gaps were sealed. Because of the exploratory nature of the investigation, the data presented are limited to a  $45^\circ$  deflection for the small single slotted flap,  $60^\circ$  deflection for the double slotted flap with the nacelles above the wing, and  $50^\circ$  deflection for nacelles below the wing. These angles were selected from a few preliminary tests made to determine flap deflections for developing high lift. Attached to the nacelles for some tests were fantails, which flared and tapered to a long thin slot. The tests covered a momentum-coefficient range from 0 to 3.0 with the model at approximately  $0^\circ$  angle of attack.

#### SYMBOLS

The coefficients of forces and moments are referred to the wind axes with the center of moments at 25 percent of the mean aerodynamic chord.

b	wing span, ft
$C_D$	drag coefficient, $\frac{\text{Drag}}{qS}$
$C_L$	lift coefficient, $\frac{\text{Lift}}{qS}$
$C_{L,F}$	jet-circulation lift coefficient

$C_m$	pitching-moment coefficient, $\frac{\text{Pitching moment}}{qS\bar{c}}$
$C_\mu$	momentum coefficient, $\frac{mV_j}{qS}$
$c$	wing chord, ft
$\bar{c}$	mean aerodynamic chord; 2.045 ft with double slotted flap and 1.65 ft with single slotted flap
$F_r$	redirected force, the resultant of lift and drag during static runs, lb
$g$	acceleration due to gravity, 32.2 ft/sec <sup>2</sup>
$m$	mass flow, $\frac{W}{g}$
$p$	free-stream static pressure, lb/sq ft
$p_t$	total pressure at nozzle exit, lb/sq ft
$q$	free-stream dynamic pressure, $\frac{\rho V^2}{2}$ , lb/sq ft
$R$	universal gas constant, $\frac{\text{ft-lb}}{\text{lb}}/\text{deg Rankine}$
$S$	wing area; 8.904 sq ft with double slotted flap and 7.23 sq ft with single slotted flap
$T$	nozzle exit temperature, deg Rankine
$V_j$	jet velocity based on isentropic expansion, $\sqrt{\frac{2\gamma}{\gamma-1} RTg \left[ 1 - \left( \frac{p}{p_t} \right)^{\frac{\gamma-1}{\gamma}} \right]}$ , ft/sec
$V$	free-stream velocity, ft/sec
$w$	weight rate of air flow from nacelles, lb/sec
$\alpha$	angle of attack of fuselage reference line
$\gamma$	ratio of specific heats for air, 1.4
$\delta_f$	flap deflection, measured with respect to wing-chord plane, deg

$\delta_j$	jet-deflection angle (measured with respect to fuselage reference line), $\tan^{-1} \frac{\text{Lift}}{\text{Drag}}$ , deg
$\delta_v$	vane deflection, measured with respect to wing-chord plane, deg
$\rho$	mass density of air, slugs/cu ft
Subscripts:	
x	horizontal direction
y	vertical direction

#### MODEL AND APPARATUS

The geometric and physical characteristics of the model, which was used in a previous investigation, are given in figure 1. The delta wing had a leading-edge sweep of  $45^\circ$ , an angle of incidence of  $1\frac{1}{2}^\circ$  with respect to the fuselage reference line, an aspect ratio of 3 for the basic wing with double slotted flap retracted, and a wing taper ratio of 0.143. The model had a double slotted flap with a vane of 8.20 percent and a flap of 30 percent of the wing chord (fig. 2) and extended from  $0.074b/2$  to  $0.751b/2$  (fig. 3). The vane alone was used to form an additional configuration which is hereinafter referred to as a small single slotted flap. For the condition of flap gaps sealed, the double slots were covered with an adhesive tape. Ordinates for the vane and flap are given in table I.

Steel pipes  $1\frac{1}{4}$  inches in diameter, attached to the balance frame and supported in proximity to the wing as shown in figure 3, were used to provide air for simulation of jet flow from engine nacelles. Steel fantail attachments to the nacelles, used in an effort to provide better distribution of jet exhaust, are shown in figure 3(b). Although the nacelle location for blowing from below the wing is not shown, the nacelle pipes were in approximately the same location relative to the wing and at the same spanwise location as for blowing from above the wing. A detailed investigation was not made to determine the optimum orientation of these nacelle pipes.

The compressed air used to simulate jet-engine exhaust was brought to the balance frame with the piping arrangement described in reference 2. The weight rate of flow was determined by means of a calibrated sharp-edge

orifice in the air supply pipe, and the pressures and temperatures for determining the jet-exit velocities were measured at the nozzle exit.

## TESTS AND CORRECTIONS

### Tests

The exploratory investigation to determine the relative merits of some external-flow jet-augmented-flap arrangements on a research model was made with the model mounted on the single-strut-support system in the Langley 300-MPH 7- by 10-foot tunnel. The tests were made at  $0^\circ$  angle of attack of the fuselage reference line at the dynamic pressures, velocities, Reynolds numbers, and momentum-coefficient ranges given in the following table:

Free-stream dynamic pressure, $q$ , lb/sq ft	Free-stream velocity, $V$ , ft/sec	Reynolds number	Range of momentum coefficient, $C_\mu$
2	41.0	526,000	0 to 3.0
5	64.9	850,000	0 to 1.2

The effective angle of attack considering jet-boundary corrections varied from 0.85 to 2.80. This correction was not applied in presenting the data, however.

With nacelles above the wing, the double slotted flap was deflected  $60^\circ$  with flap gaps sealed and open and fantails on and off; the small single slotted flap was deflected  $43^\circ$  with flap gap open and fantails on. With nacelles below the wing, the double slotted flap was deflected  $50^\circ$  with flap gaps open and fantails off. All deflections were measured with respect to the wing chord.

### Corrections

Jet-boundary corrections applied to the drag were obtained by the methods of reference 4. The magnitude of the corrections was determined by considering only the aerodynamic forces (circulation lift effects) on

the model that resulted after the jet-reaction components had been subtracted from the data as follows:

$$C_D = C_{D_{\text{measured}}} + 0.0147 [C_L - C_{\mu} \sin(\delta_j + \alpha)]^2$$

Blocking corrections were applied by the methods of reference 5. Tare corrections were applied to the lift, pitch, and drag to account for nacelle-pipe effects.

## RESULTS AND DISCUSSION

### Tests With $q = 0$

The redirected thrust  $F_r$  was obtained from blowing tests with  $q = 0$  from the resultant of lift and drag forces. The initial thrust  $mV_j$  is the original momentum of the air jets at the nacelle exits. The ratio  $F_r/mV_j$  and the angle  $\delta_j$  through which  $F_r$  is redirected give an indication of flap effectiveness. Both of these factors are presented on a polar plot in figure 4. The ratio  $F_r/mV_j$  as a function of  $mV_j$  is also presented in the lower portion of this figure. Generally,  $\delta_j$  was less than  $\delta_f$ , and over the major portion of the momentum range the values of  $F_r/mV_j$  fell between 0.50 and 0.60. Over most of the momentum range of the investigation, the lowest values of  $F_r/mV_j$  were obtained with the condition of flap gaps sealed and fantails on the nacelles. This fact probably resulted from the imposed spanwise spreading of the jet with a larger component in the lateral direction compared with that of the other arrangements.

### Lift Coefficients

The results of the limited investigation show that values of  $C_L$  were generally larger than those of  $C_{\mu}$ , and values of  $C_{L,\Gamma}$  were generally larger than the jet reaction at the flap  $F_r/mV_j C_{\mu} \sin(\alpha + \delta_j)$ . A value for  $C_{L,\Gamma}$  of about 2.12 was obtained at  $C_{\mu} = 1.5$  for the condition of flap gaps sealed and fantails attached to the nacelles (fig. 5(a)). When the fantails were removed without unsealing the gaps (figs. 5(d) and 6), the value of  $C_L$  at  $C_{\mu} = 2.00$  was reduced from about 3.69 to 3.10. The higher lift coefficient with the fantail on

the model (even though this configuration had a smaller reaction component as discussed previously) can be attributed to the larger circulation lift resulting from distribution of high momentum air over a greater part of the wing span. The importance of providing sealed gaps for blowing over flaps from above the wing is shown by figures 5(b) and 7 (gaps unsealed and fantails on) where the lowest value of  $C_L$  for a given value of  $C_{\mu}$  was produced:  $C_L = 1.61$  at  $C_{\mu} = 2.0$ . Some improvement occurred when the fantails were removed with gaps open (figs. 5(e) and 8); however, the total lift in this case was only slightly larger than the momentum coefficient:  $C_L = 2.10$  at  $C_{\mu} = 2.0$ . The data necessary to compute the jet reaction component were not obtained for the flap conditions shown in figures 5(b) and 5(e).

For the condition of fantails on and gaps open, the lift produced with the small single slotted flap,  $C_L = 2.42$  at  $C_{\mu} = 2.0$  (figs. 5(c) and 7), was larger than that produced with the double slotted flap (fig. 5(b)).

When the nacelles were placed beneath the wing with gaps unsealed and fantails removed (figs. 5(f) and 8), a value of  $C_L$  of 3.05 was produced at  $C_{\mu} = 2.0$ . Although the basic lift resulting from flap deflection at  $C_{\mu} = 0$  for this configuration (fig. 5(f)) was larger than the best upper-surface blowing arrangement (fig. 5(a)), the total lift was less because the circulation lift component was smaller.

#### Pitching-Moment Coefficient

Negative pitching moments were exhibited for all the flaps tested in this investigation with about the same increase of  $C_m$  with  $C_{\mu}$  over the lift-coefficient range of the investigation. When an untrimmed value of  $C_L$  of 2.0 is used as a reference, the loss in lift due to a down load at the horizontal tail needed for longitudinal trim varied from about 16 percent to 20 percent of the total lift for an assumed tail length of 1.55c. This required down load would exceed the capabilities of the existing horizontal tail which produced a static margin of about 20 percent when flaps were up. These large diving moments resulting from increased lift on the wing from upper-surface blowing are similar to those obtained in other jet-flap investigations where forced circulation on the tail, the use of nose jets, or blowing canards have been considered as trimming devices (for example, ref. 1).



### Drag Coefficient

At a given value of  $C_L$ ,  $C_D$  varied widely with flap configuration as might be expected if consideration is made of the differences in reaction component, reaction angle, and circulation lift for the various configurations. However, at a given value of  $C_{\mu}$  the drag coefficient was generally proportional to lift coefficient.

### SUMMARY OF RESULTS

An exploratory wind-tunnel investigation has been made to determine the lift effects of blowing over flaps from nacelles mounted above the wing. Results of this investigation may be summarized as follows:

1. Values of jet-circulation lift coefficient larger than the jet reaction were produced with upper-surface blowing over flaps. For instance, at a momentum coefficient of 1.5, a jet-circulation lift coefficient of 2.12 was obtained with the gaps of the double slotted flaps sealed and fantails attached to the nacelles.

2. When the gaps between the flap and wing were unsealed, a large detrimental effect on the lift capability was produced by upper-surface blowing.

3. For nacelle location above the wing and with the flap gap sealed, larger lift coefficients were obtained when the fantails were added to the nacelles.

4. The longitudinal trim problems (resulting from large diving moments) for upper-surface-blowing jet-augmented flaps are similar to those encountered with other jet-augmented-flap systems.

Langley Aeronautical Laboratory,  
National Advisory Committee for Aeronautics,  
Langley Field, Va., February 25, 1958.

## REFERENCES

1. Lowry, John G., Riebe, John M., and Campbell, John P.: The Jet-Augmented Flap. Preprint No. 715, S.M.F. Fund Paper, Inst. Aero. Sci., Jan. 1957.
2. Lockwood, Vernard E., Turner, Thomas R., and Riebe, John M.: Wind-Tunnel Investigation of Jet-Augmented Flaps on a Rectangular Wing To High Momentum Coefficients. NACA TN 3865, 1956.
3. Davenport, Edwin E.: Wind-Tunnel Investigation of External-Flow Jet-Augmented Double Slotted Flaps on a Rectangular Wing at an Angle of Attack of  $0^\circ$  to High Momentum Coefficients. NACA TN 4079, 1957.
4. Gillis, Clarence L., Polhamus, Edward C., and Gray, Joseph L., Jr.: Charts for Determining Jet-Boundary Corrections for Complete Models in 7- by 10-Foot Closed Rectangular Wind Tunnels. NACA WR L-123, 1945. (Formerly NACA ARR L5G31.)
5. Herriot, John G.: Blockage Corrections for Three-Dimensional-Flow Closed-Throat Wind Tunnels, With Consideration of the Effect of Compressibility. NACA Rep. 995, 1950. (Supersedes NACA RM A7B28.)

TABLE I.- ORDINATES OF VANE AND FLAP

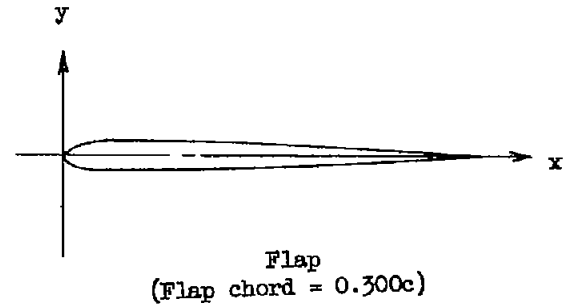
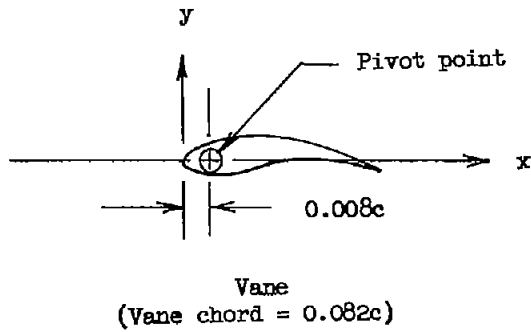

x, percent of vane chord	y, percent of vane chord, for -	
	Lower surface	Upper surface
0	0	0
1.7	-2.6	2.1
6.7	-4.9	4.8
20.0	-5.2	9.0
33.2	-2.0	10.7
46.7	-.3	10.1
60.0	-.2	7.5
86.6	-4.5	-2.2
100.0	-1.0	-9.7

x, percent of flap chord	y, percent of flap chord, for -	
	Lower surface	Upper surface
0	-1.6	-1.6
3.7	-3.1	.9
7.3	-3.2	1.9
11.0	-3.3	2.8
14.5	-3.5	3.5
16.9	-3.5	3.5
33.3	-2.7	2.7
50.0	-1.9	1.9
66.7	-1.1	1.1
83.3	-.4	.4
100.0	-.9	.1

**Wing:**

- Aspect ratio-----3.000
- Span-----5.168 ft
- Area-----8.904 sq ft
- Root chord-----30.15 ft
- Mean aerodynamic chord-----2.045 ft
- Airfoil section (parallel to air stream) NACA 65A004
- Leading edge sweep-----45°
- Incidence-----15°

**Horizontal tail:**

- Aspect ratio-----4.00
- Area-----1.36 sq ft
- Airfoil section-----NACA 65A006

**Vertical tail:**

- Area-----1.913 sq ft
- Airfoil section-----NACA 65A006

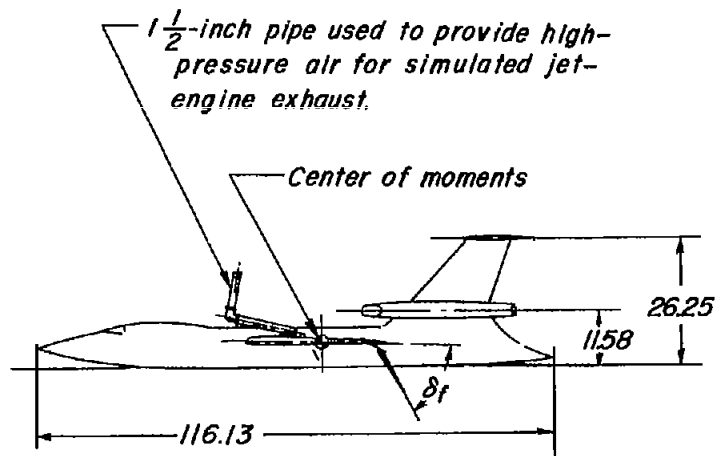
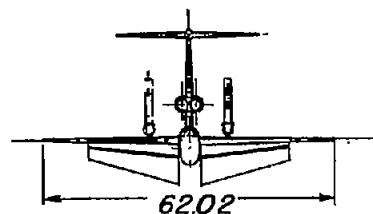
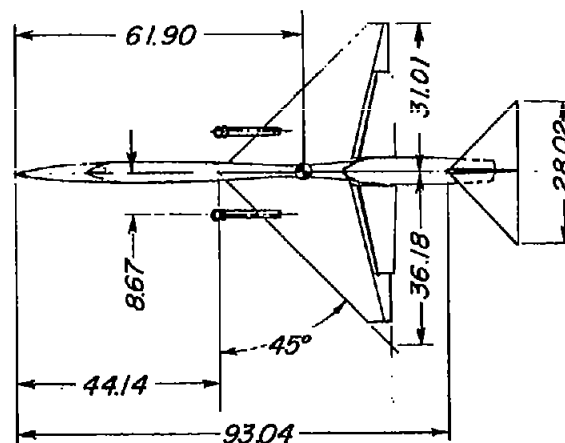

Figure 1.- Three-view drawing of research model with jet-augmented flaps. All dimensions are in inches.

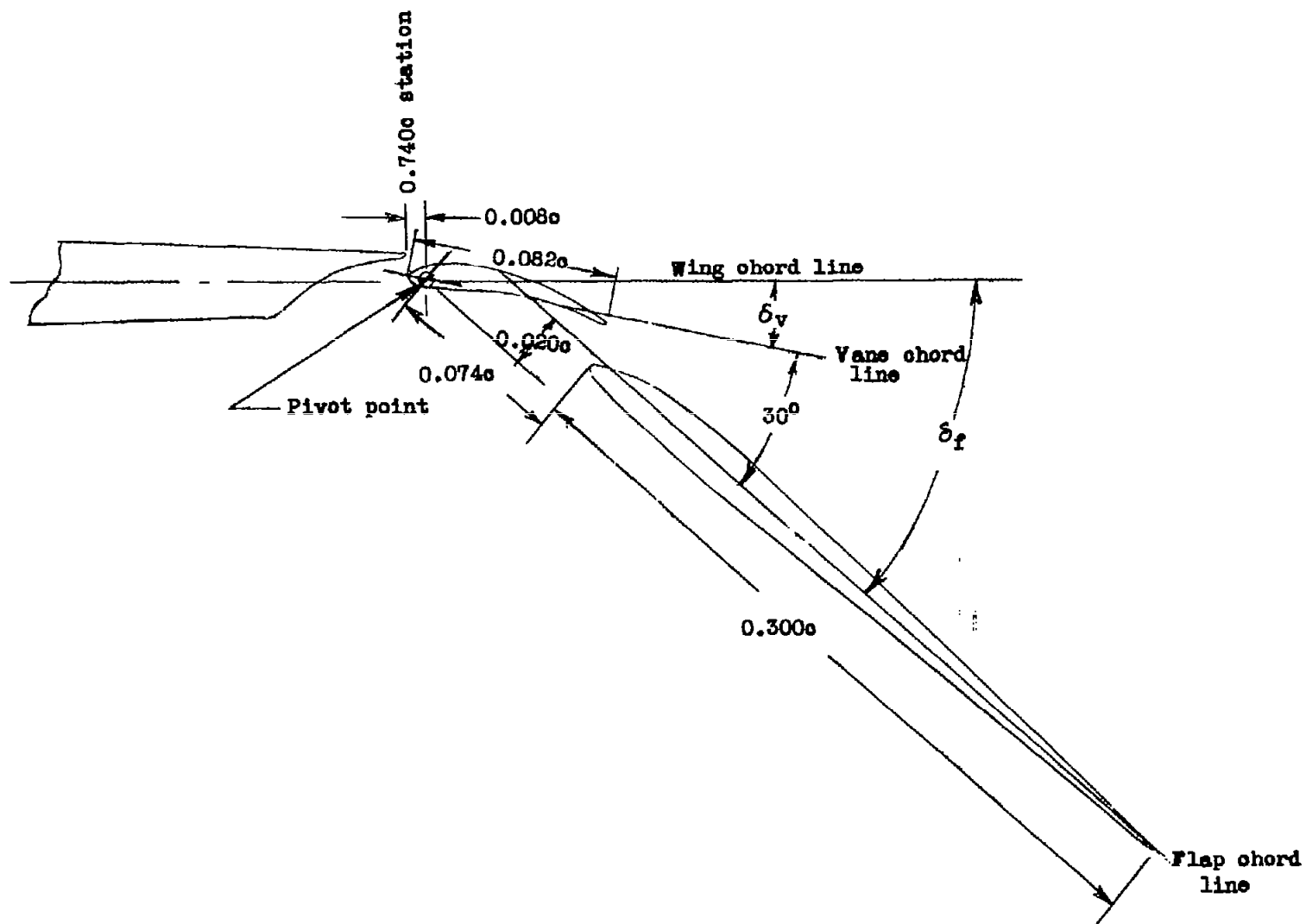
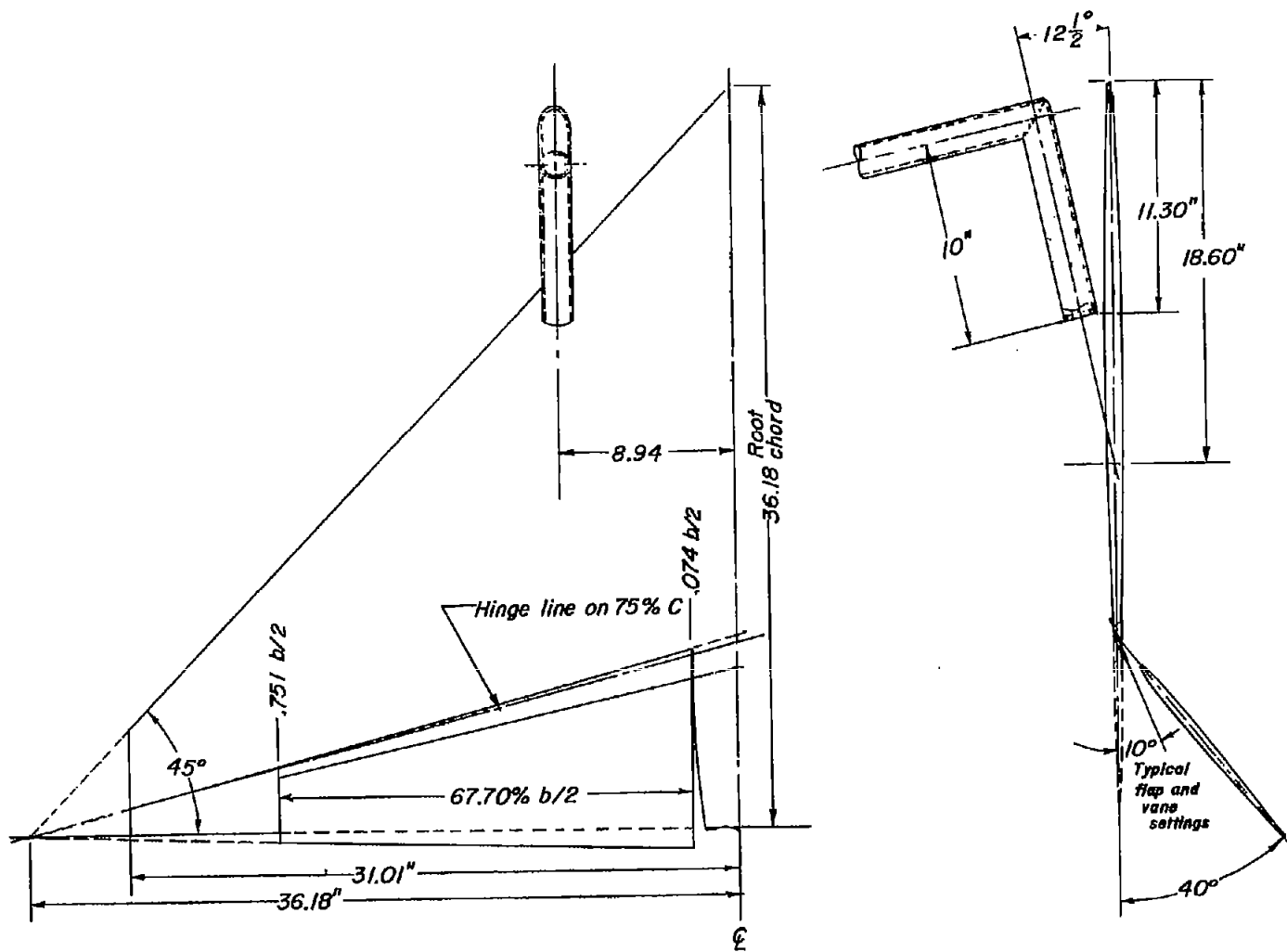
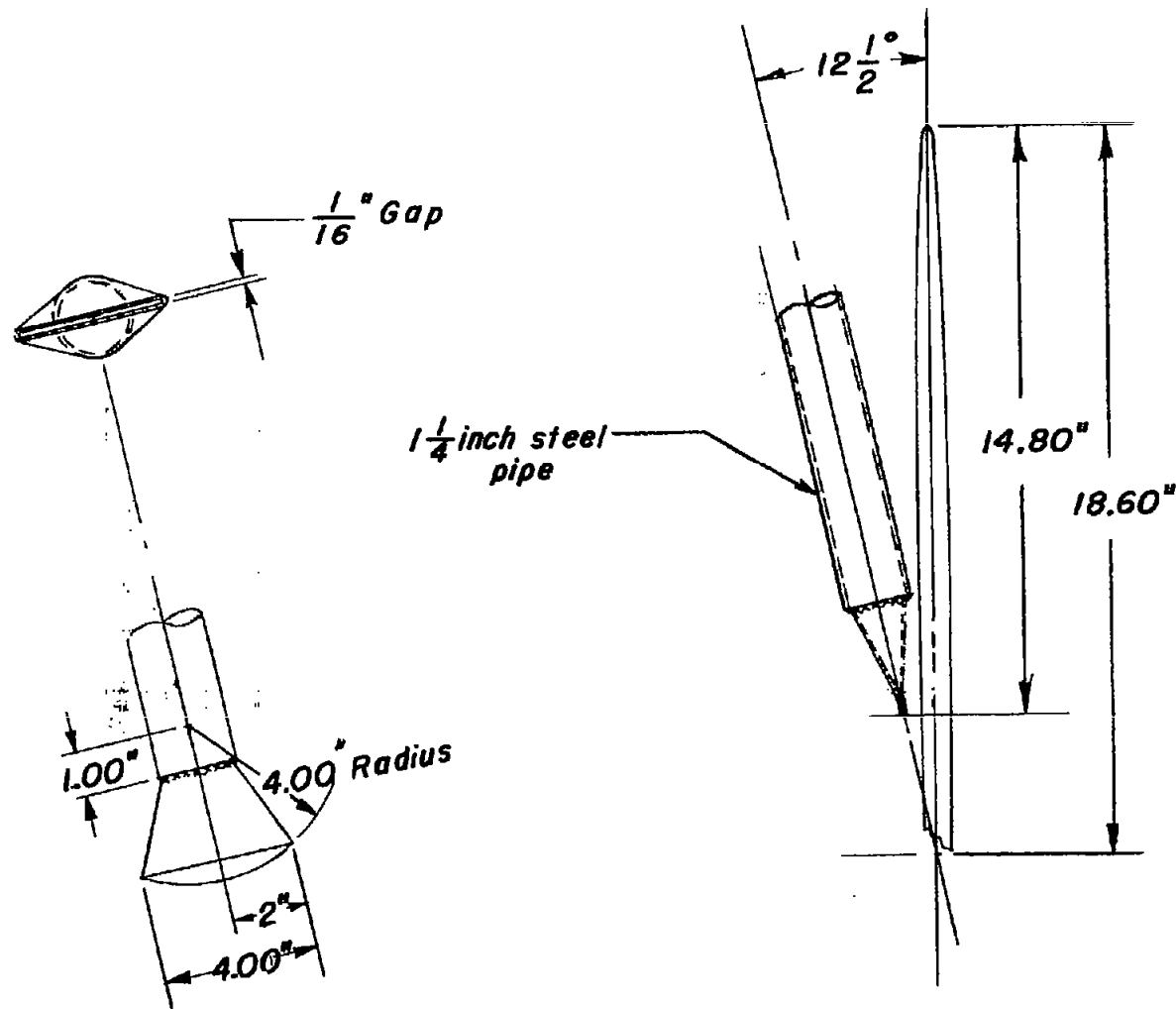

Figure 2.- Double slotted flap at a typical wing section of the model.



(a) Plain nacelles.

Figure 3.- Nacelle and wing details for twin-nacelle blowing over double slotted flap.



(b) Fantail nacelles.

Figure 3.- Concluded.

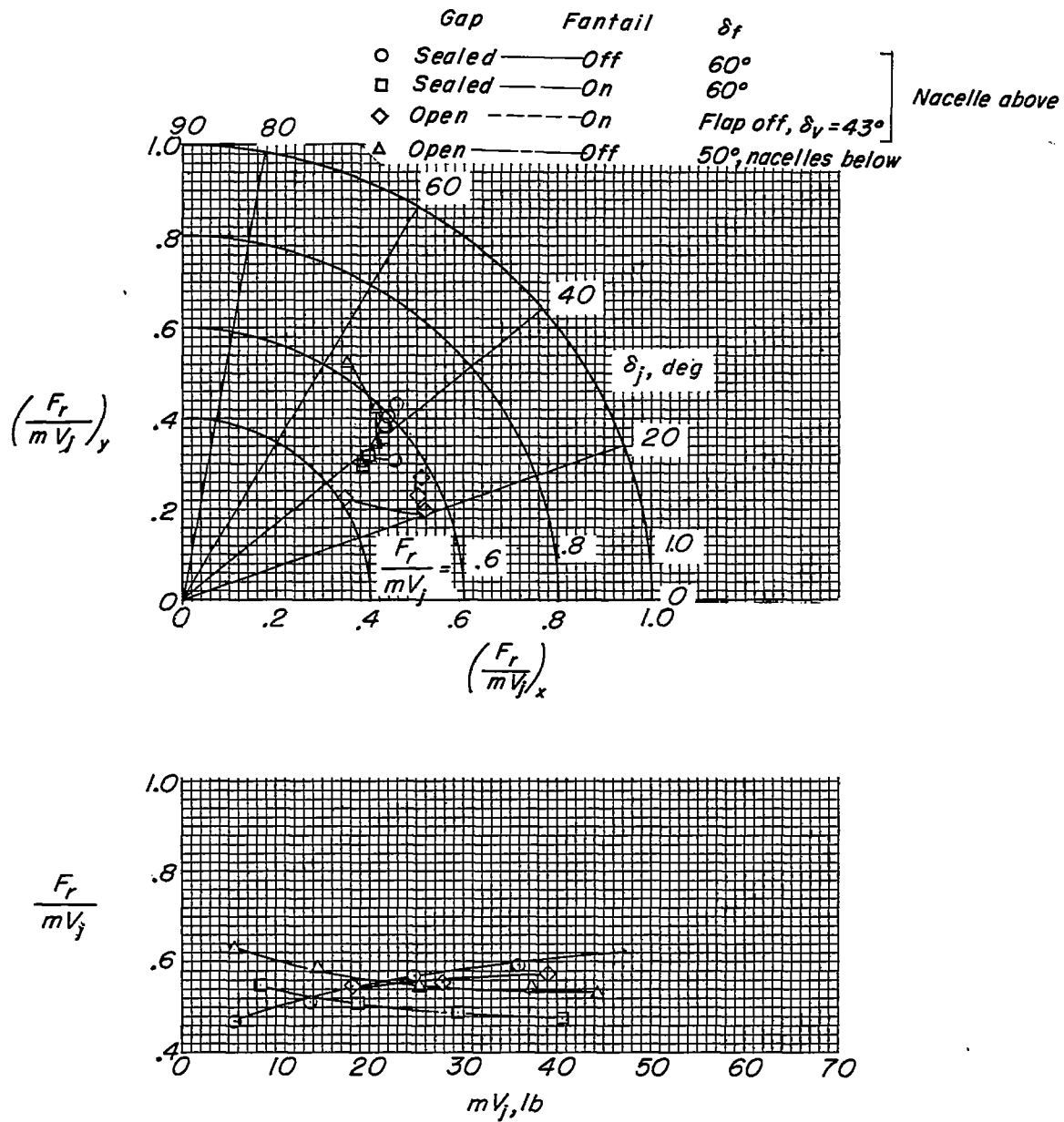
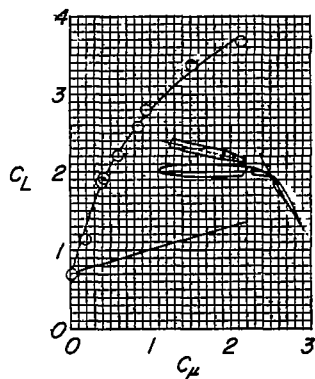
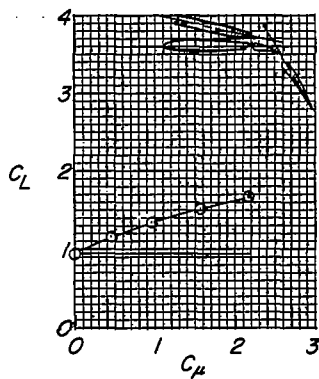

Figure 4.- Variation of turning effectiveness with increase in momentum for  $q = 0$ .





(a) Fantails on;  
double slotted  
flap; gap  
sealed;  $\delta_f = 60^\circ$ .



(b) Fantails on;  
double slotted  
flap; gaps open;  
 $\delta_f = 60^\circ$ .

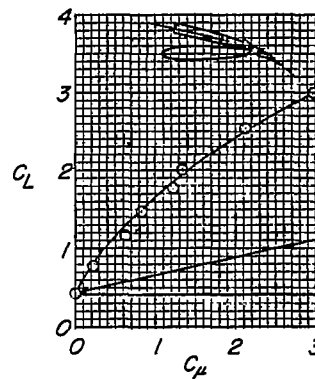

(c) Fantails on;  
single slotted  
flap; gap open;  
 $\delta_v = 43^\circ$ .

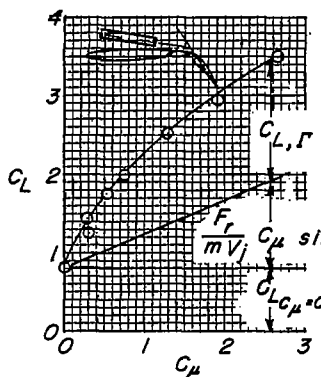

(d) Fantails off;  
double slotted  
flap; gaps sealed;  
 $\delta_f = 60^\circ$ .

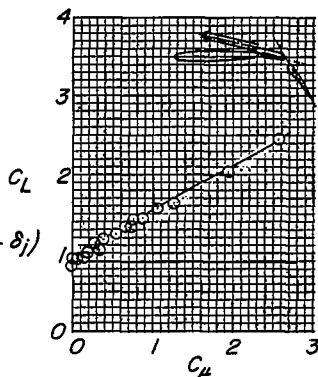

(e) Fantails off;  
double slotted  
flap; gaps open;  
 $\delta_f = 60^\circ$ .

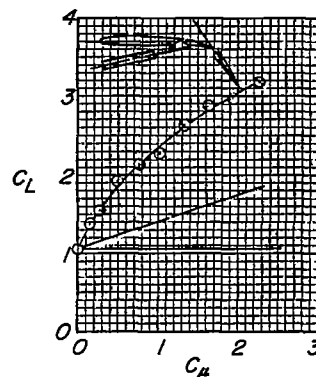

(f) Fantails off;  
nacelles below;  
double slotted  
flap; gaps open;  
 $\delta_f = 50^\circ$ .

Figure 5.- Summary of lift characteristics.

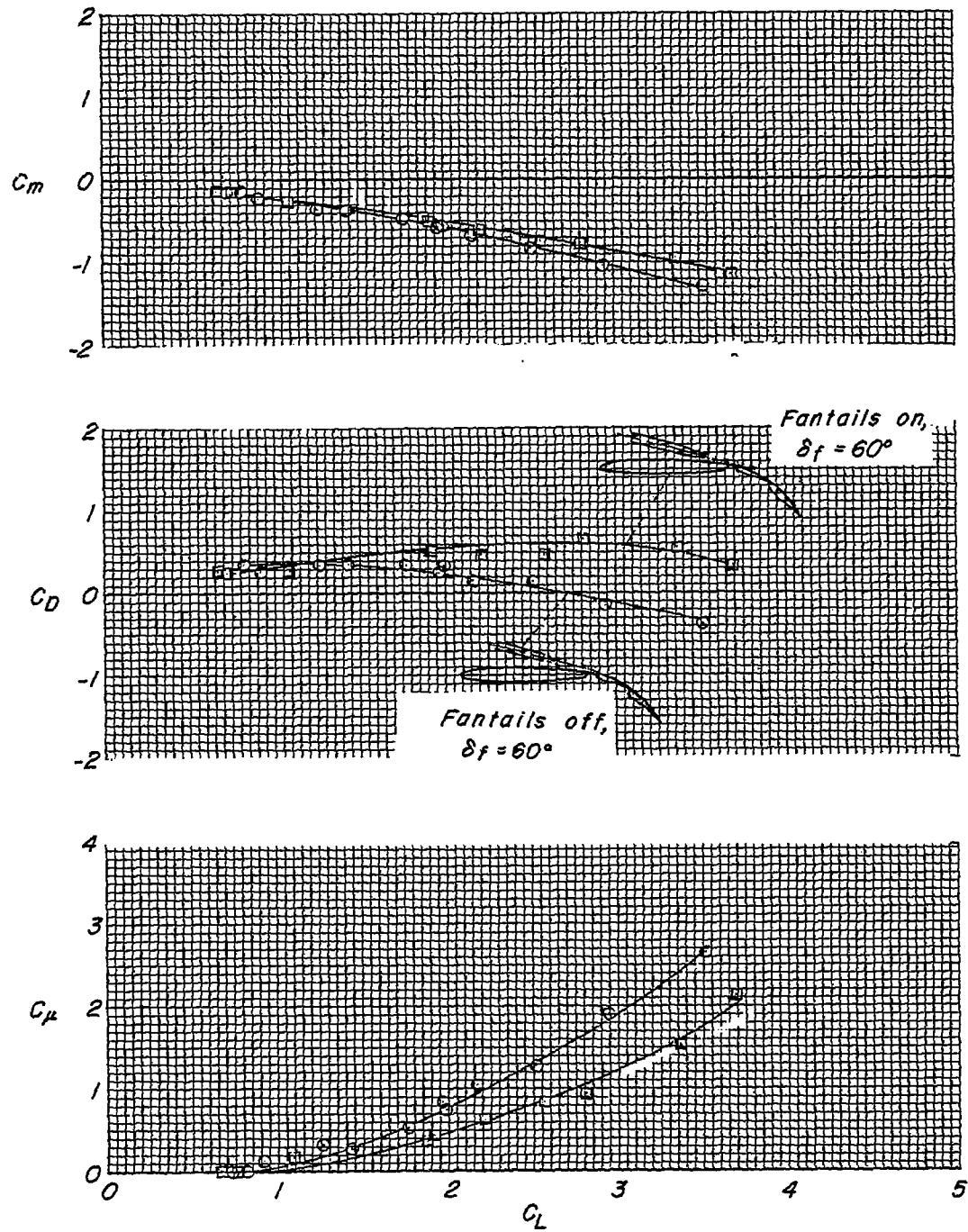

Figure 6.- Aerodynamic characteristics of model with double slotted flaps. Flap gaps sealed, nacelles above wing, fantails on and off nacelles.

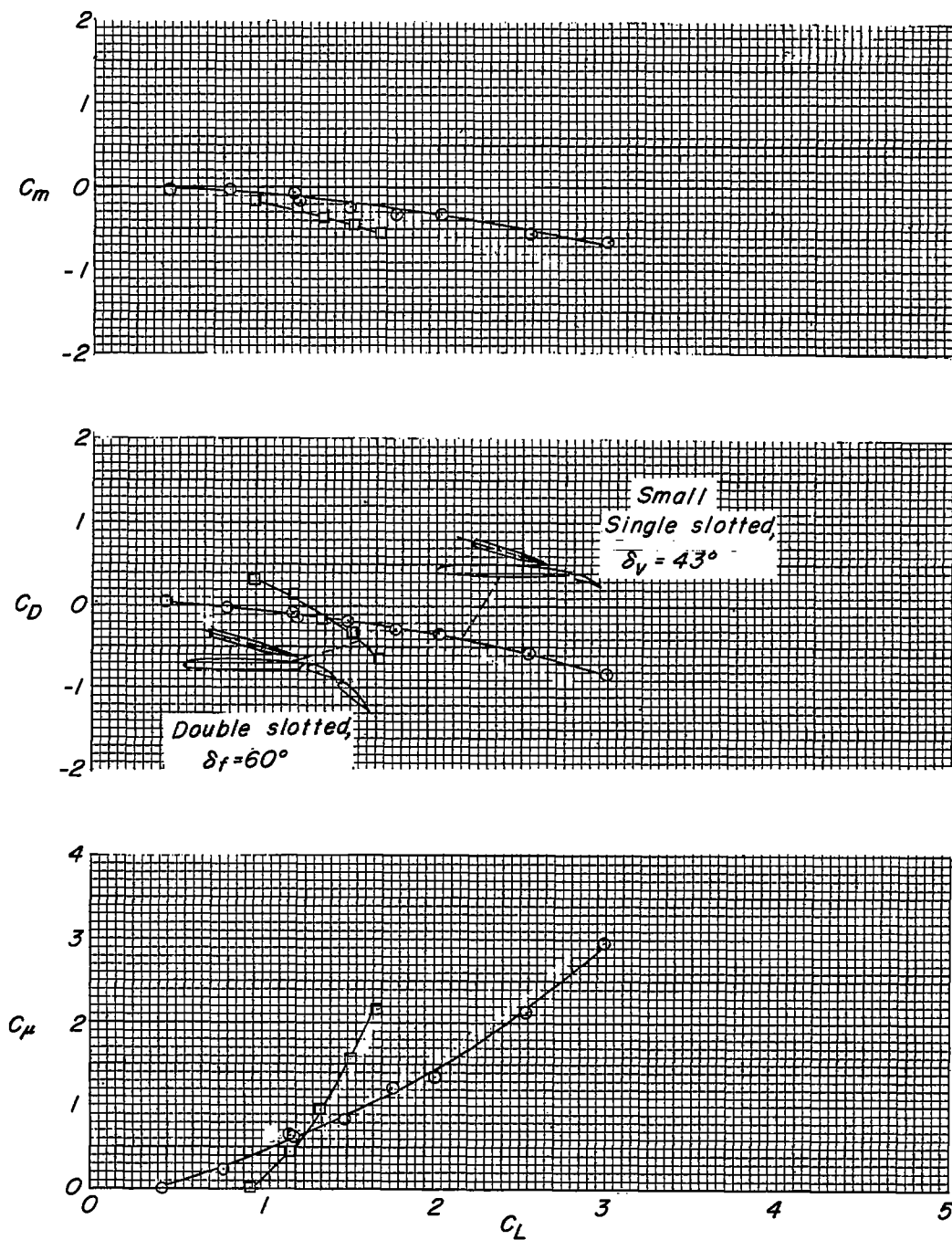

Figure 7.- Aerodynamic characteristics of model. Single and double slotted flaps, flap gaps open, nacelles above wing, fantails on nacelles.

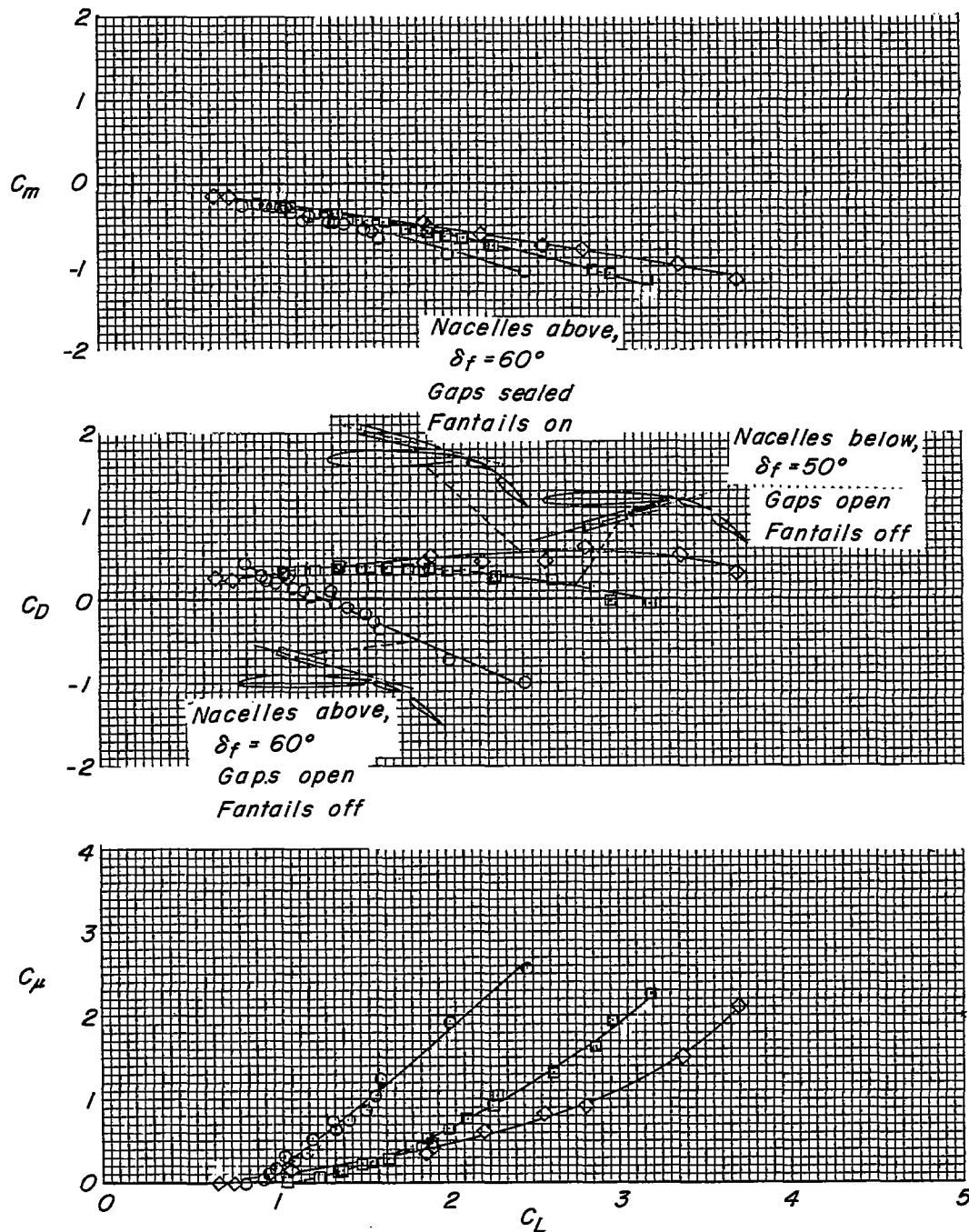

Figure 8.- Aerodynamic characteristics of model with double slotted flaps. Flap gaps open, nacelles above and below wings, fantails off nacelles.