

~~CONFIDENTIAL~~

NACA RM No. L8A05a

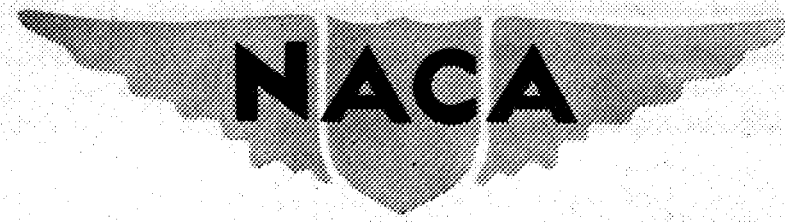

RESEARCH MEMORANDUM

RESULTS OBTAINED DURING ACCELERATED TRANSONIC TESTS
OF THE BELL XS-1 AIRPLANE IN FLIGHTS
TO A MACH NUMBER OF 0.92

By

Hubert M. Drake, Milton D. McLaughlin,
and Harold R. Goodman

Langley Memorial Aeronautical Laboratory
Langley Field, Va.

This document contains classified information
whose release would be injurious to the national defense.
Its transmission or the revelation of its contents in any manner to an unauthorized person is prohibited by law.
Classification so classified may be imparted
only to persons in the military and naval
services of the United States Government who have a legitimate interest
therein, and to United States citizens who are
loyal and trustworthy and who may be
informed thereof.

CLASSIFICATION CHANGED TO UNCLASSIFIED
AUTHORITY: NACA RESEARCH ABSTRACT NO. 113
EFFECTIVE DATE: MARCH 19, 1957
WHL

NATIONAL ADVISORY COMMITTEE FOR AERONAUTICS

WASHINGTON

April 19, 1948

~~CONFIDENTIAL~~

NATIONAL ADVISORY COMMITTEE FOR AERONAUTICS

RESEARCH MEMORANDUM

RESULTS OBTAINED DURING ACCELERATED TRANSONIC TESTS

OF THE BELL XS-1 AIRPLANE IN FLIGHTS

TO A MACH NUMBER OF 0.92

By Hubert M. Drake, Milton D. McLaughlin,
and Harold R. Goodman

SUMMARY

An accelerated flight program using the Bell XS-1 airplane has been undertaken to explore the transonic-speed range. The flying was done by an Air Force pilot, and the data reduction and analysis were made from NACA instrumentation by NACA personnel. This paper presents the results of tests obtained up to a Mach number of 0.92 at altitudes around 30,000 feet.

The data obtained show that the airplane has experienced most of the difficulties expected in the transonic range, but that it can be flown satisfactorily to a Mach number of at least 0.92 at altitudes above 30,000 feet. Longitudinal trim changes have been experienced but the forces involved have been small. The elevator effectiveness decreased about one-half with increase of Mach number from 0.70 to 0.87. Buffeting has been experienced in level flight but it has been mild and the associated tail loads have been small. No aileron buzz or other flutter phenomena have been noted.

INTRODUCTION

After the completion of the acceptance tests on the thick-wing Bell XS-1 airplane (see references 1 and 2) and in order to explore the transonic-speed range as rapidly as possible, an accelerated program has been undertaken for the XS-1 having the 8-percent-thick wing and the 6-percent-thick tail. Because of the purpose of the program only a limited amount of instrumentation has been included, and no attempt has been made to obtain detailed investigations of any variables other than those immediately necessary to permit safe penetration as rapidly as possible into the transonic-speed range.

The present program is a cooperative one between Wright Field Flight Test Division and the NACA. The airplane is flown by an Air Force pilot,

and the data reduction and analysis are made from NACA instrumentation by NACA personnel.

The present paper gives some of the experimental results obtained in this program up to a Mach number of 0.92. The data consist, for the most part, of time histories of mild maneuvers which illustrate the behavior of the airplane at transonic speeds. Some analysis figures, however, are included to indicate trends shown by the data.

SYMBOLS

W	airplane gross weight, pounds
n	normal acceleration in g units
V_1'	indicated airspeed uncorrected for position error, miles per hour
H	pressure altitude uncorrected for position error, feet
q	dynamic pressure, pounds per square foot
S	wing area (130 sq ft)
S_t	tail area (26 sq ft)
M'	free-stream Mach number uncorrected for position error
M	free-stream Mach number corrected for position error
C_n	airplane normal-force coefficient $\left(\frac{nW}{qS}\right)$
C_{n_t}	tail normal-force coefficient $\left(\frac{\text{Aerodynamic shear load}}{S_t q}\right)$
C_{L_A}	airplane lift coefficient (Measured normal-force coefficient is assumed to equal the lift component.)
$\Delta\delta_e$	change in elevator position, degrees
$\Delta\alpha_t$	change in angle of attack of stabilizer, degrees
i_t	stabilizer setting, degrees

TEST AIRPLANE AND INSTRUMENTATION

The XS-1 is a rocket-propelled research airplane having an 8-percent-thick wing and 6-percent-thick horizontal tail. A three-view layout of the airplane is shown in figure 1, and the physical characteristics are given in table I. The weight conditions of the airplane during flight are:

Launching weight, pounds	12,365
Launching center-of-gravity position (percent M.A.C.)	22.1
Landing weight, pounds	7115
Landing center-of-gravity position (percent M.A.C.)	25.3

Airspeed, altitude, elevator position, normal, transverse, and longitudinal acceleration, shear and bending moment on the right horizontal tail and bending moment on the right wing are recorded internally on standard NACA instruments. In addition, airspeed, altitude, normal acceleration, elevator force, elevator, stabilizer, and right aileron angles are telemetered to a ground station and recorded.

The elevator angles are measured relative to the stabilizer, and the stabilizer angle is measured relative to the airplane center line. The aileron angle is measured relative to the neutral position.

A calibration of the airspeed head has been made up to a Mach number of 0.92 by the radar tracking method. The results of the calibration are given in figure 2 as a plot of the ratio of error in Mach number to corrected Mach number against corrected Mach number.

TESTS, RESULTS, AND DISCUSSION

In the present program the tests are made in such a manner as to penetrate the transonic region as rapidly as possible. Only mild accelerated maneuvers have, therefore, been performed and the data obtained have consisted of various time histories to illustrate various points of interest which have occurred during the tests. The data have not been completely analyzed although a few analysis figures are included to show the trends that have occurred.

Figure 3 shows the time history of a portion of a run in which one, two, and three rockets were turned on. The figure also compares the values recorded in the airplane with those telemetered to the ground station. The comparisons show good agreement and it may be stated that the differences recorded are less than 1 percent of the full-scale range of the instrument involved. Since the telemeter accelerometer was undamped, reading was difficult when buffeting occurred; therefore, the telemetered record of normal acceleration does not extend to the end of the run (fig. 3).

In figure 4 several quantities related to the stability changes that have occurred are plotted against Mach number. Since in a given run the Mach number and the weight W change rapidly, the results are given for a selected airplane normal-force coefficient of about 0.2. The data have been obtained from two flights and include only those points around 1 g where the angular acceleration is known to be a minimum. The pilot felt that with the 1° stabilizer setting, the large trim forces, and the forward position of the stick precluded going to Mach numbers greater than 0.88. With the stabilizer at 2.2° the pilot continued flight to a Mach number of 0.92. In going from a Mach number of 0.70 to 0.92, three trim changes were noted: an airplane pitch-down tendency near 0.80, a pitching up above 0.87, and at 0.92 the airplane is again showing a pitch-down tendency.

Previous tests on conventional fighters have usually stopped at the first trim change because of the large control forces involved. However, with the 2.2° stabilizer setting, it may be seen that the range of forces is small (about 10 lb) although the change of elevator position is about 4° . In the case of the 2.2° stabilizer setting the pilot did not object to the trim changes. The forces were light because the elevators are very small (mean chord, 0.46 ft), and the flights were made at about 30,000 feet. At lower altitudes or on a larger similar airplane these characteristics would probably be objectionable. These flight data are in general agreement with data from the Langley 8-foot high-speed tunnel and from wing flow tests of XS-1 models.

A measure of the apparent elevator effectiveness is obtained from the deflections required for trim at the two stabilizer settings. The change in the apparent elevator effectiveness with Mach number is also shown in figure 4 where it is indicated that the effectiveness is reduced about 50 percent when the Mach number is increased from 0.70 to 0.87. In spite of this large reduction in elevator effectiveness, the greater portion of the trim change is caused by the variation of the pitching moment of the wing and fuselage with Mach number. This change is indicated by the measured horizontal tail loads of figure 4.

Figure 5 gives the available data on longitudinal stability in accelerated flight. The figure presents the variation of elevator position and force with lift coefficient as measured in turns at Mach numbers of 0.75, 0.80, and 0.85. The data at a Mach number of 0.75 are from reference 1. The data in this figure show that as the Mach number is increased from 0.75 to 0.85 the apparent stability at low lift coefficients is increased, whereas the stability at high lift coefficients is unchanged. Some of the difference shown may be a result of the thicker wing of the airplane of reference 1 and the change of elevator effectiveness with Mach number.

A time history of a turn to the stall is shown in figure 6, and a time history of an unaccelerated stall is shown in figure 7. Both of

these stalls were in the clean condition. Figure 8 shows the variation of elevator angle with lift coefficient recorded during the 1 g stall.

The stabilizer actuator was originally set at 1° per second, but the pilot felt that this rate was too slow for good control; therefore, the rate was increased to 2° per second. A time history of a stabilizer deflection at this new rate is shown in figure 9. The more rapid rate of stabilizer setting caused a rapid change of acceleration and caused the pilot to overshoot the desired setting by 0.5° . After he became accustomed to the new rate, the pilot felt that it was satisfactory.

A time history of measured quantities obtained during a turn into the buffet region with 2.2° stabilizer setting is shown in figure 10. A similar time history of a turn below the buffet boundary and during an approximately level-flight run within the buffet region with 1.0° stabilizer incidence is shown in figure 11. The aerodynamic wing and tail loads presented are measured values corrected for inertia loads. Figure 12 shows the envelope of lift and Mach number combinations obtained within the buffet region for a stabilizer setting 2.2° . Limit lift has been determined from measurements in which lift ceased to increase although, as shown in figure 7, increasing up elevator is being applied. These data were obtained in level flight or gradual turns and are for a stabilizer setting of 2.2° only. Although buffeting has been encountered in level flight, it has not been severe enough to prove bothersome to the pilot. The maximum buffeting tail loads were obtained at limit lift from a Mach number of 0.76 to 0.80 and were of the order of ± 400 pounds. At Mach numbers greater than 0.80 the buffeting loads decreased and up to a Mach number of 0.92 were less than ± 250 pounds. Here again, the low value of these loads is due in part to the altitude (30,000 ft) at which the tests were made.

There has been no evidence of one-dimensional flutter or "buzz" up to a Mach number of 0.92. In addition to the thin wing section, one reason for the absence of buzz is the large amount of friction, about 20 foot-pounds, in the aileron-control system. The aerodynamic hinge moment corresponding to a Mach number of 0.85 at 30,000 feet, neglecting Mach number effects on the hinge moment coefficient, is about 7 foot-pounds per degree. Although hydraulic dampers have been installed, they have not been used.

No signs of buzz or changes in the aileron floating tendencies have been reported, but the pilot has noted a right wing heaviness which was first noted at about $M = 0.85$ and which increased up to a Mach number of 0.92. Figure 13 shows the right aileron angle plotted as a function of Mach number, and the gradual increase in downward deflection appears to confirm the pilot's observation. It was thought that one of the spoilers located on the upper surface of the wing might be deflecting and thus changing the airplane trim, but bolting down the spoilers had no effect on the wing heaviness.

CONCLUSIONS

The data obtained to date on the Bell XS-1 airplane show that most of the difficulties expected in the transonic-speed range have been experienced and the airplane can be flown satisfactorily to a Mach number of at least 0.92 at altitude. Detailed conclusions are:

1. Although longitudinal trim changes have been experienced between $M = 0.80$ and $M = 0.92$, the control forces associated with the trim changes have been small and the pilot has been able to control the airplane without difficulty.

2. The effectiveness of the elevator as compared with that of the stabilizer in changing trim decreased about 50 percent with an increase of Mach number from 0.70 to 0.88.

3. Buffeting has been experienced in level flight, but up to a Mach number of 0.92 it has been very mild and the tail loads associated with the buffeting have been small.

4. No aileron buzz or other flutter phenomena have been experienced up to a Mach number of 0.92. The airplane became right-wing heavy but could be trimmed with aileron.

Langley Memorial Aeronautical Laboratory
National Advisory Committee for Aeronautics
Langley Field, Va.

REFERENCES

1. Williams, Walter C., Forsyth, Charles M., and Brown, Beverly P.: General Handling-Qualities Results Obtained during Acceptance Flight Tests of the Bell XS-1 Airplane. NACA RM No. L8A09, 1948.
2. Beeler, De E., and Mayer, John P.: Measurements of the Wing and Tail Loads during the Acceptance Tests of Bell XS-1 Research Airplane. NACA RM No. L7L12, 1948.

TABLE I

PHYSICAL CHARACTERISTICS OF BELL XS-1 AIRPLANE

Engine	Reaction Motors, Inc. Model 6000C4
Rating, static thrust at sea level for each of the four rocket cylinders, lb	1500
Propellant	
Fuel	Diluted ethyl alcohol
Oxidizer	Liquid oxygen
Propellant flow (approx.), lb/sec/cylinder	7.9
Fuel feed	High pressure nitrogen gas
Weight for acceptance tests	
Maximum	
With full load and incorporating 8 percent wing, lb	12365
Minimum	
Landing condition, 8 percent wing, lb	7115
Wing loading	
Maximum (8 percent wing with fuel load), lb/sq ft	94.4
Center-of-gravity travel, percent mean aerodynamic chord	Maximum 22.1 percent full load to 25.3 percent empty
Over-all height, ft	10.85
Over-all length, ft	30.90
Wing	
Area (including section through fuselage) sq ft	130
Span, ft	28
Airfoil section	NACA 65,-110 (a=1) and NACA 65,-108 (a=1)
Mean aerodynamic chord, in.	57.71
Location (aft of leading-edge root chord), in.	6.58
Aspect ratio	6
Root chord, in.	74.2

TABLE I

PHYSICAL CHARACTERISTICS OF BELL XS-1 AIRPLANE -- Continued

Tip chord, in.	37.1
Taper ratio	2:1
Incidence, deg	
Root	2.5
Tip	1.5
Sweepback (leading edge), deg	5.05
Dihedral (chord plane), deg	0
Wing flaps (plane)	
Area, sq ft	11.6
Span, ft	5.83
Chord (root), in.	14.84
Chord (tip), in.	10.58
Travel, deg	60
Aileron (internal pressure balance)	
Area (each aileron behind hinge line), sq ft	3.15
Span, ft	5.8
Travel, deg	± 12
Chord, percent wing chord	15
Root-mean-square chord, ft	0.565
Horizontal tail	
Area, sq ft	26.0
Span, ft	11.4
Aspect ratio	5
Distance from airplane design center of gravity	
to 25 percent mean aerodynamic chord of tail, ft	13.3
Stabilizer travel, deg, (power actuated)	5 nose up and 10 down
Elevator (no aerodynamic balance)	
Area, sq ft	5.2
Travel from stabilizer, deg	16 up and 7 down
Root-mean-square chord, ft	0.464
Chord, percent horizontal tail chord	20

TABLE I

PHYSICAL CHARACTERISTICS OF BELL XS-1 AIRPLANE -- Concluded

Vertical tail	
Area (excluding dorsal fin), sq ft	25.6
Total height above horizontal stabilizer, in.	61.25
Fin	
Area (excluding dorsal fin), sq ft	20.4
Offset from thrust axis, deg	0
Rudder (no aerodynamic balance)	
Area, sq ft	5.2
Span, ft	6.58
Travel, deg	± 15
Root-mean-square chord, ft	0.798
Chord, percent vertical tail chord	20



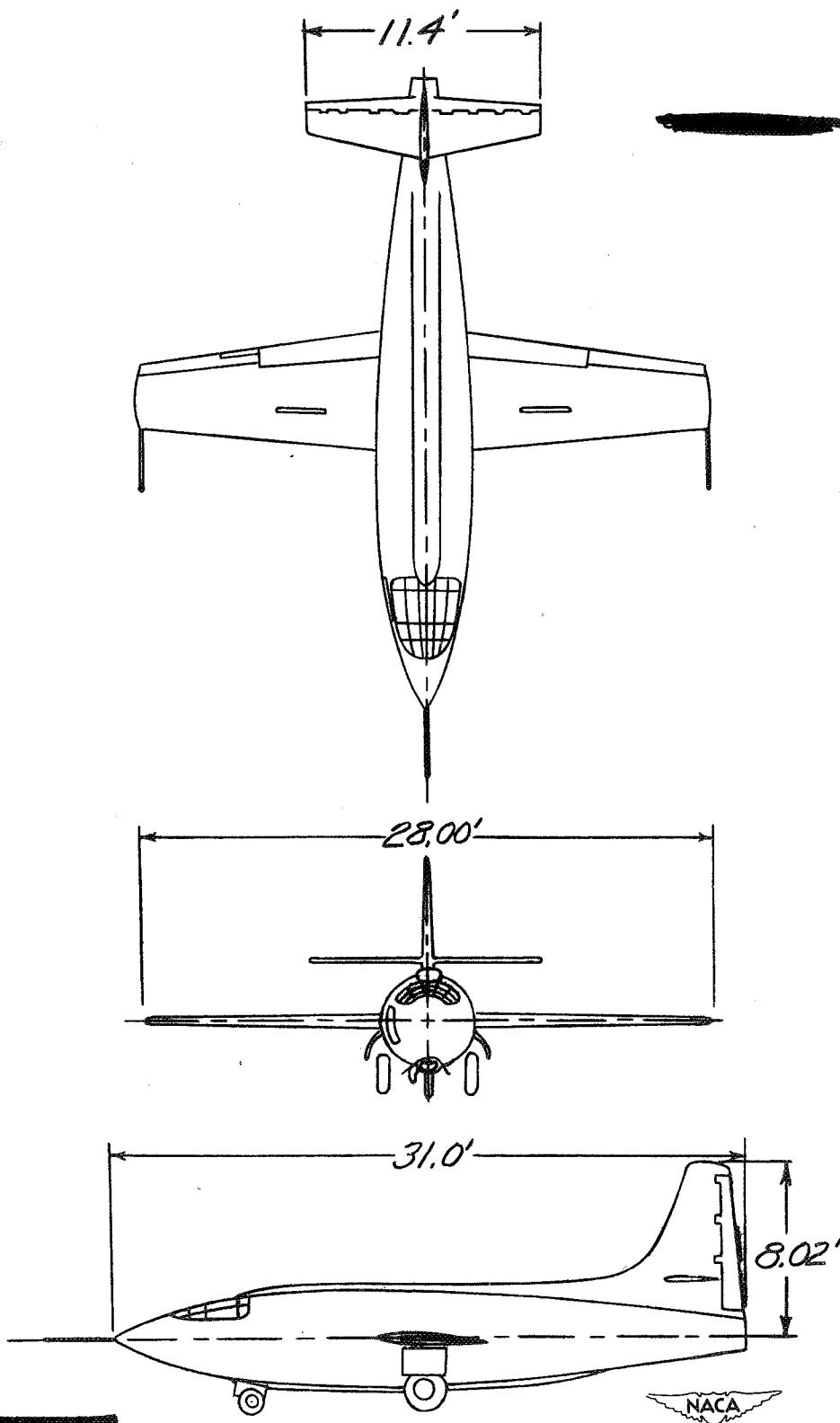

Figure 1.- Three-view drawing, X8-1 airplane.

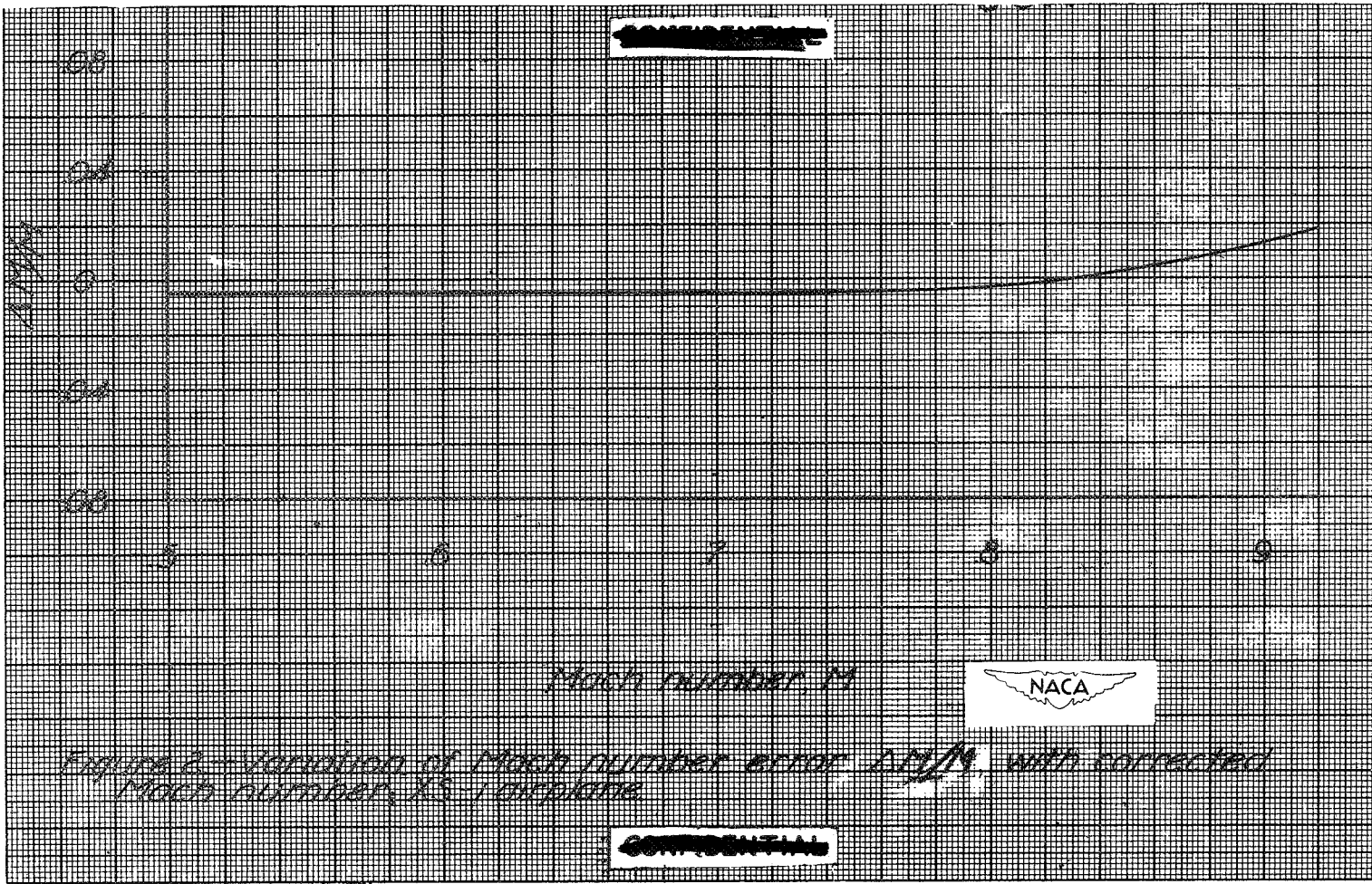

Figure 6 - Variation of Mach number error M/M with corrected Mach number, M , airplane

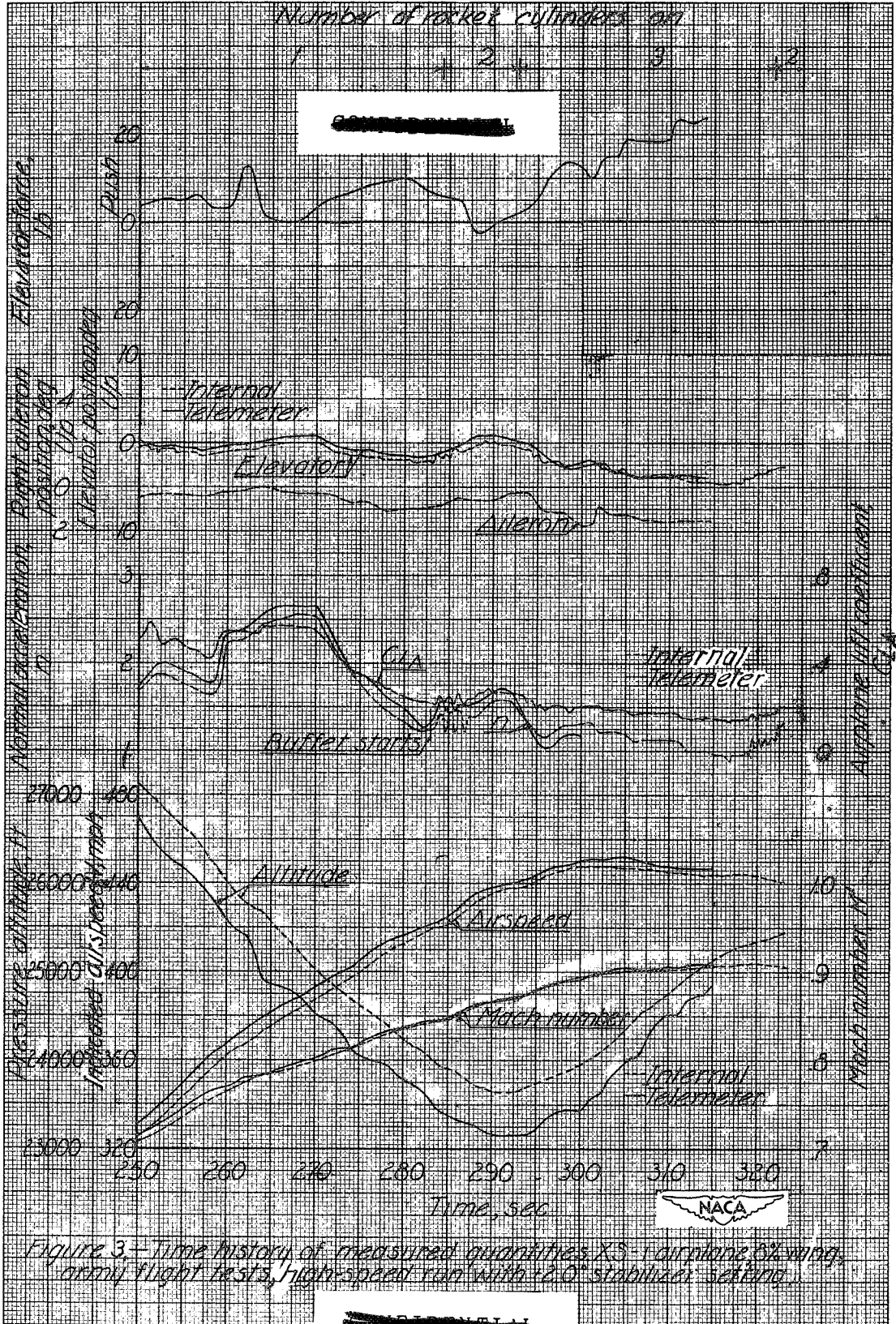
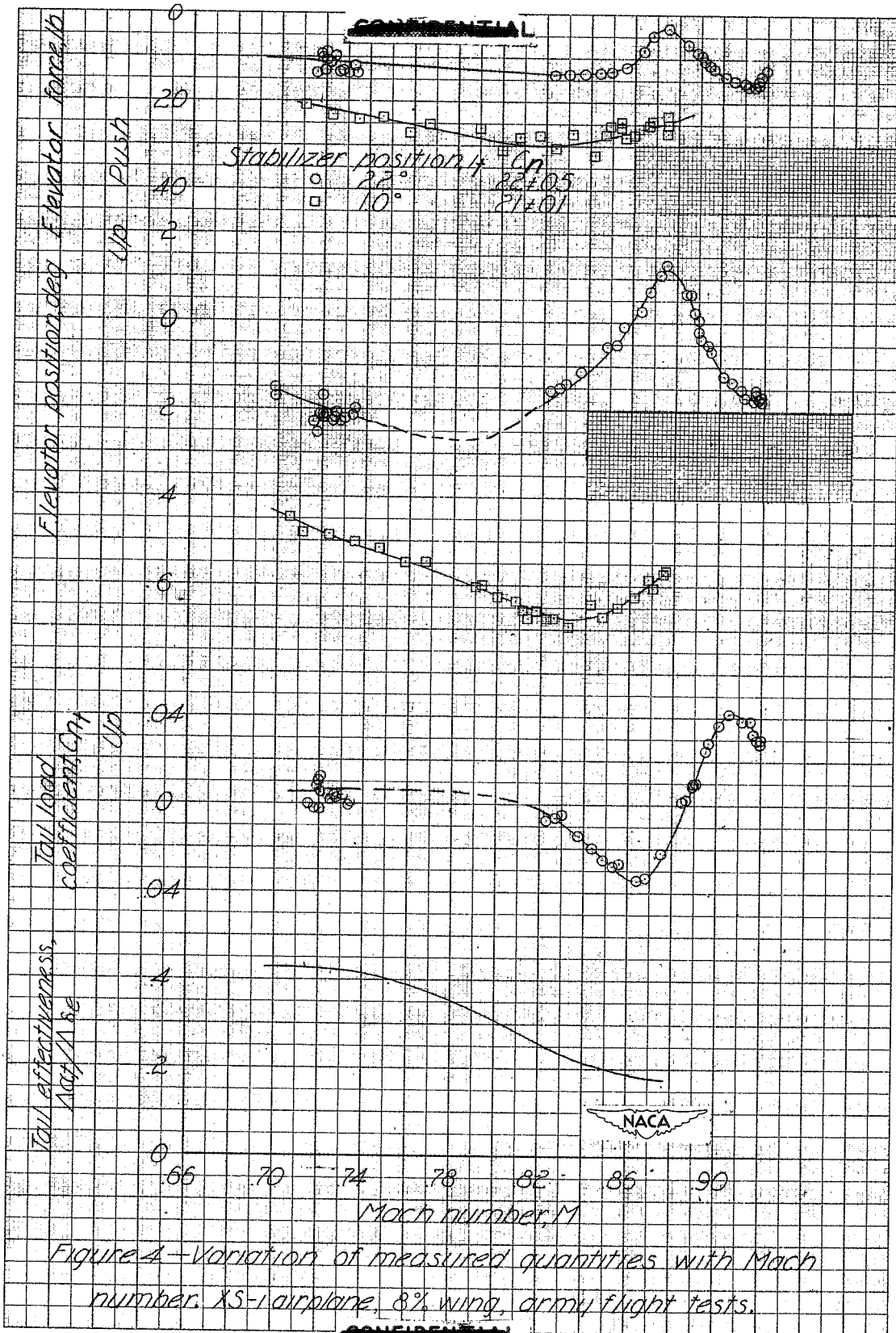

Figure 3.- Time history of measured quantities XS-1 airplane, 6 1/2 wing, army flight tests, high-speed run with +2.0° stabilizer setting.

~~CONFIDENTIAL~~



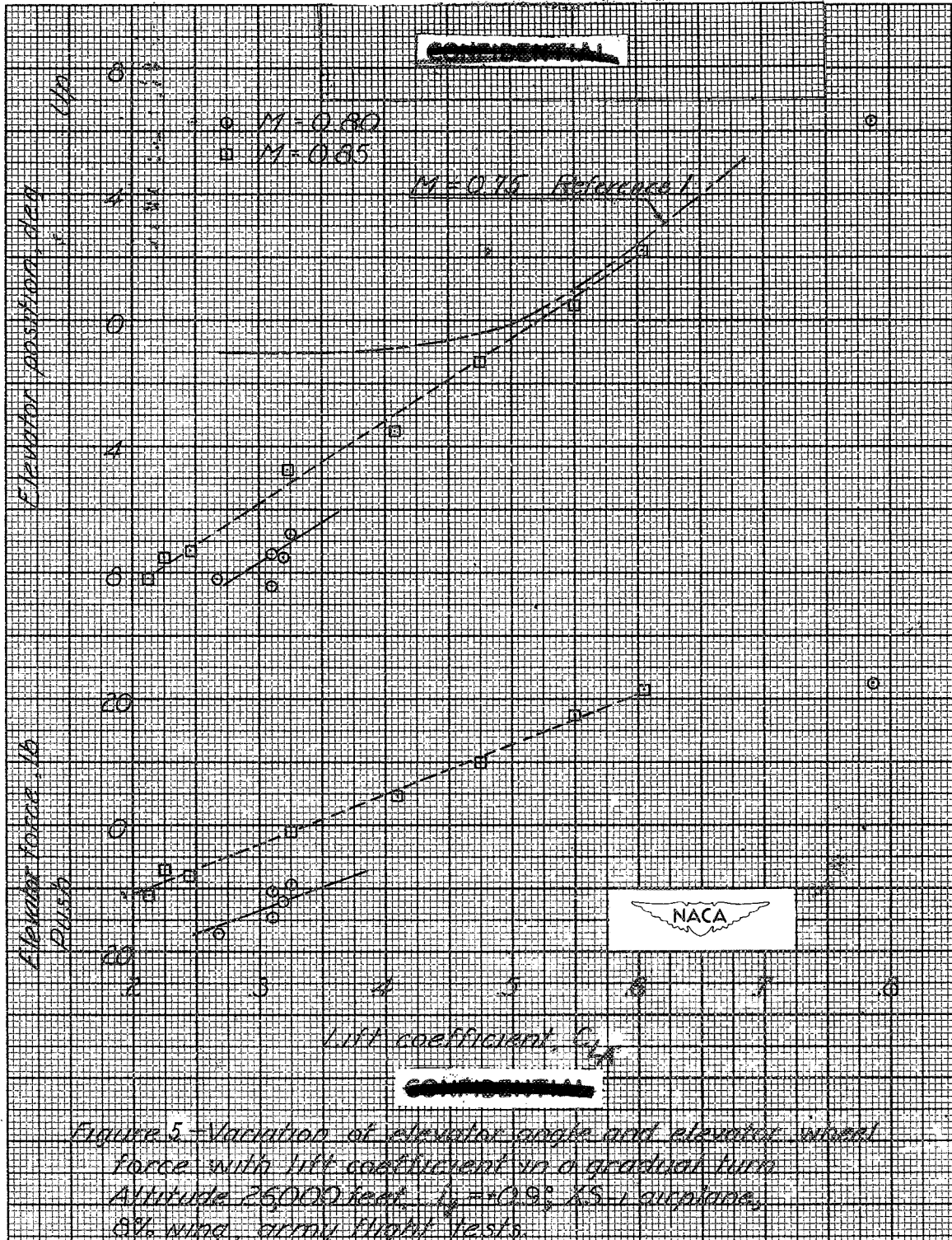
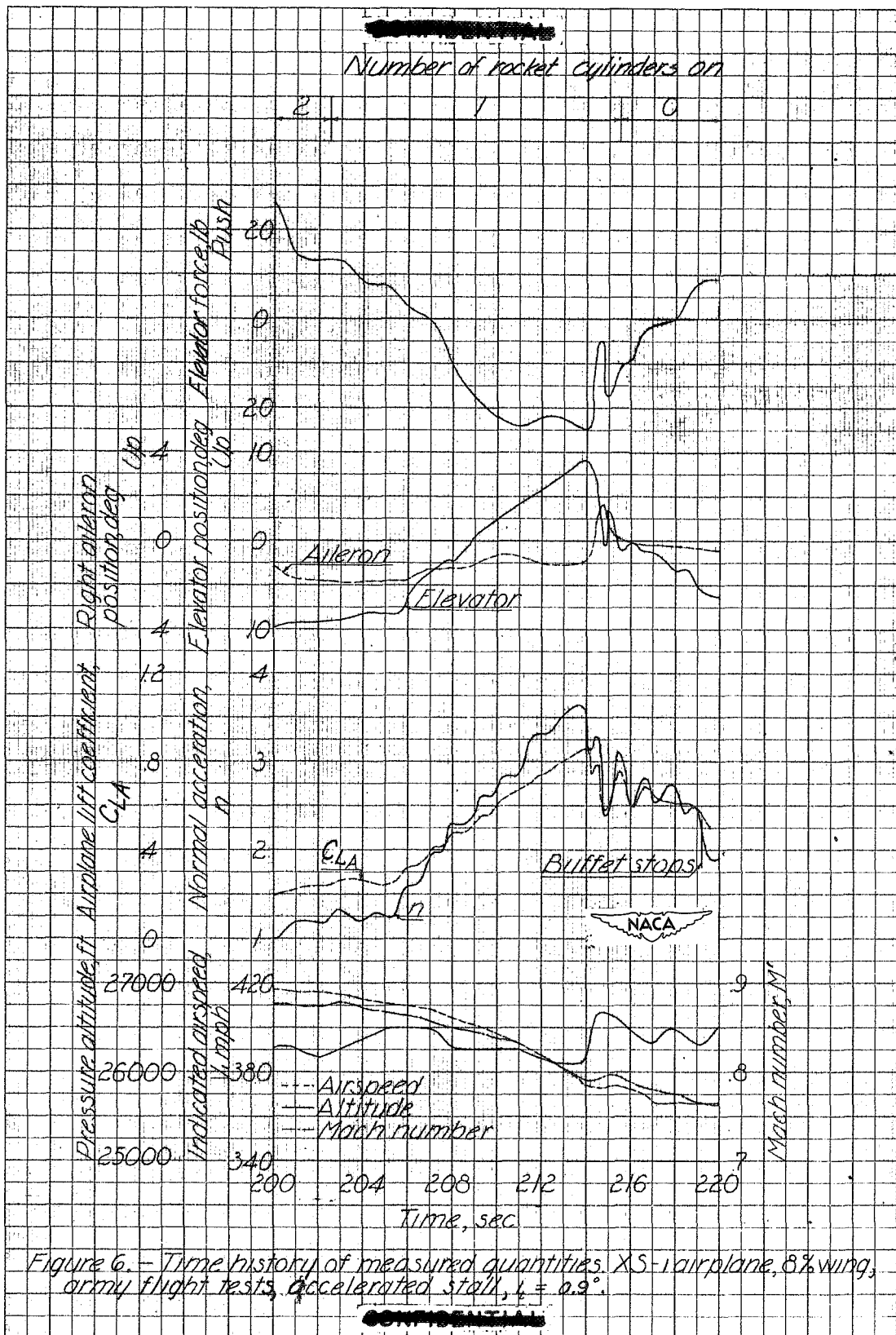

Figure 5 - Variation of elevator angle and elevator wheel force with lift coefficient in a gradual turn. Altitude 26,000 feet, $\beta = +0.9^\circ$, LS-1 airplane, 8% wing, army flight tests.



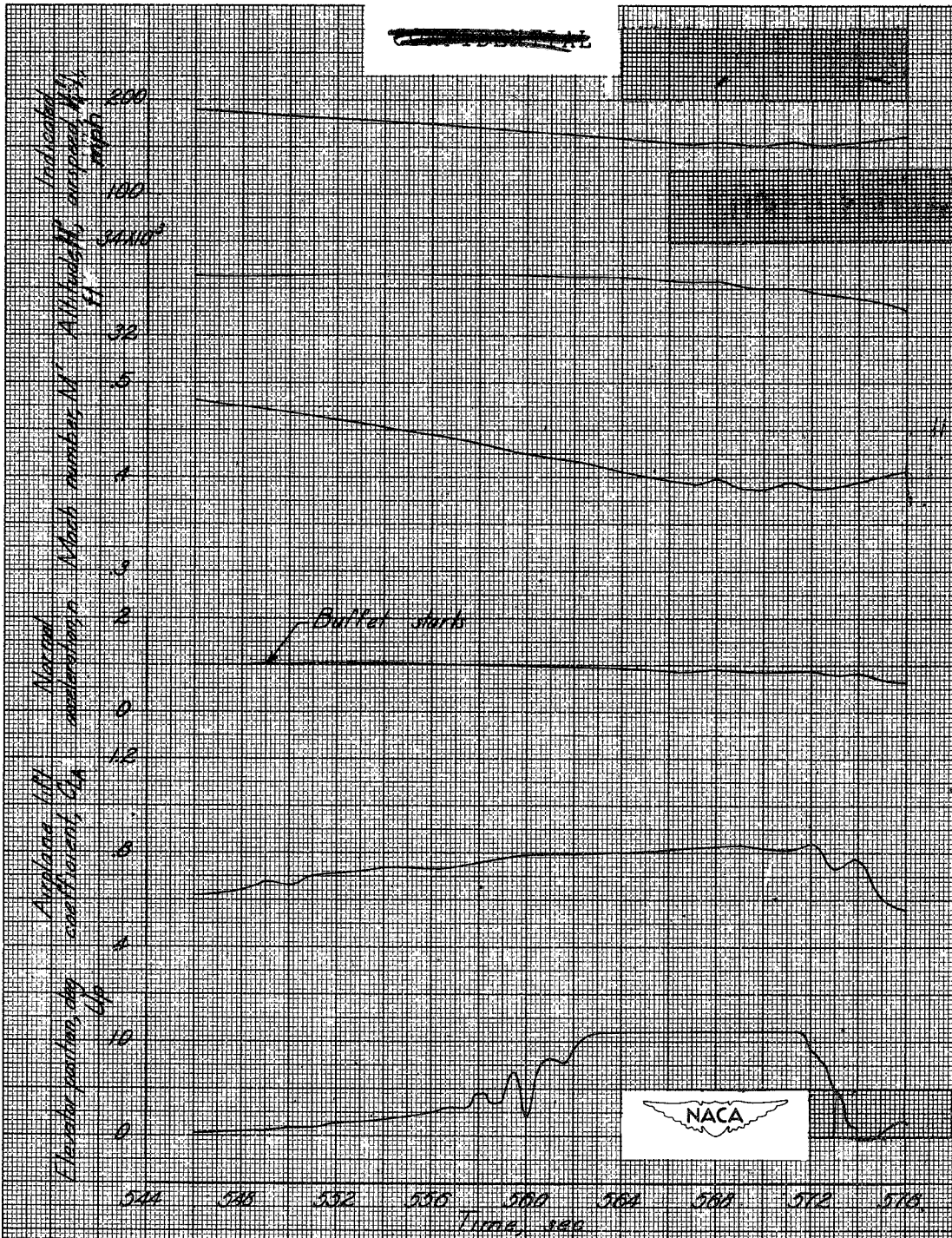
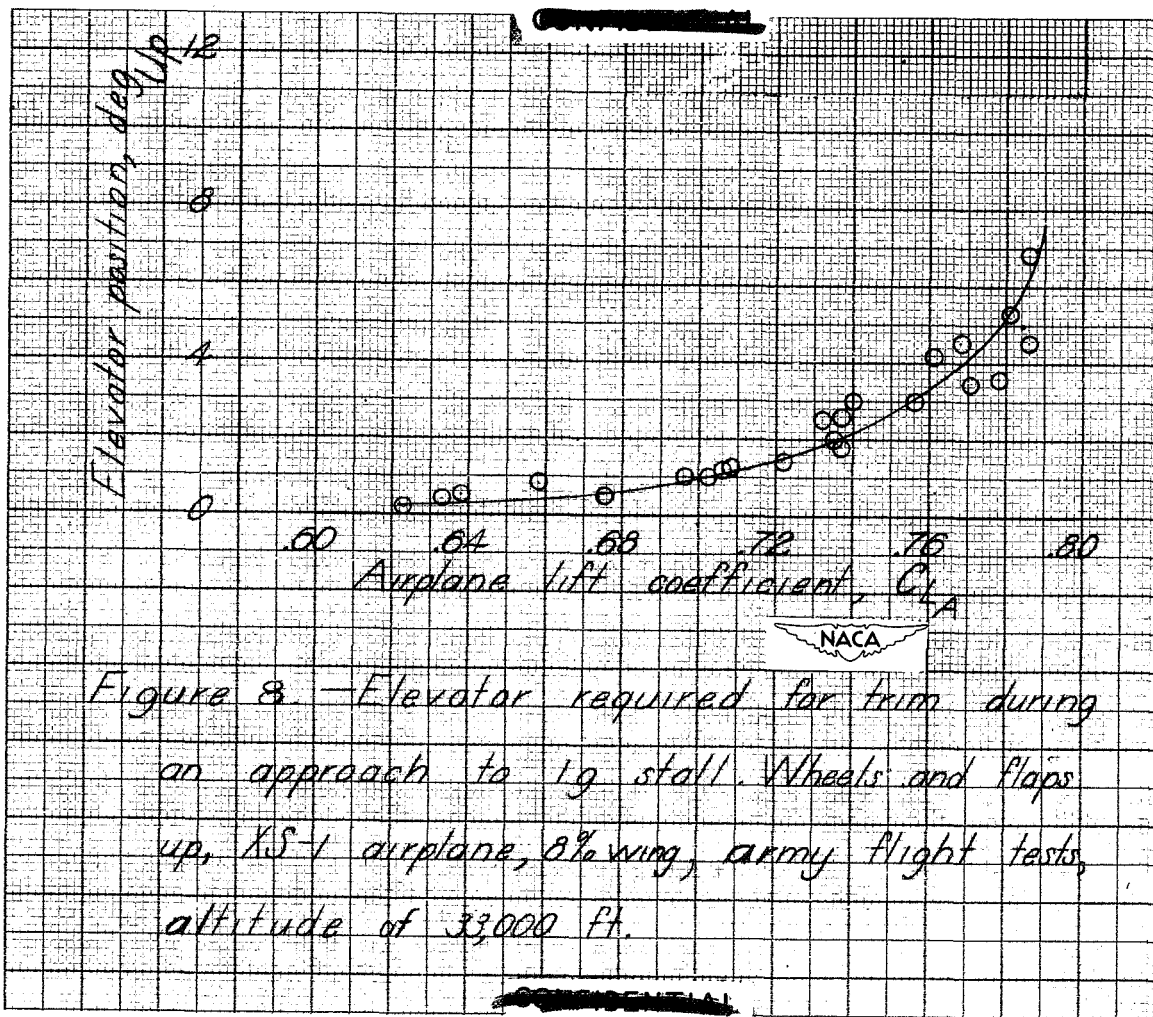
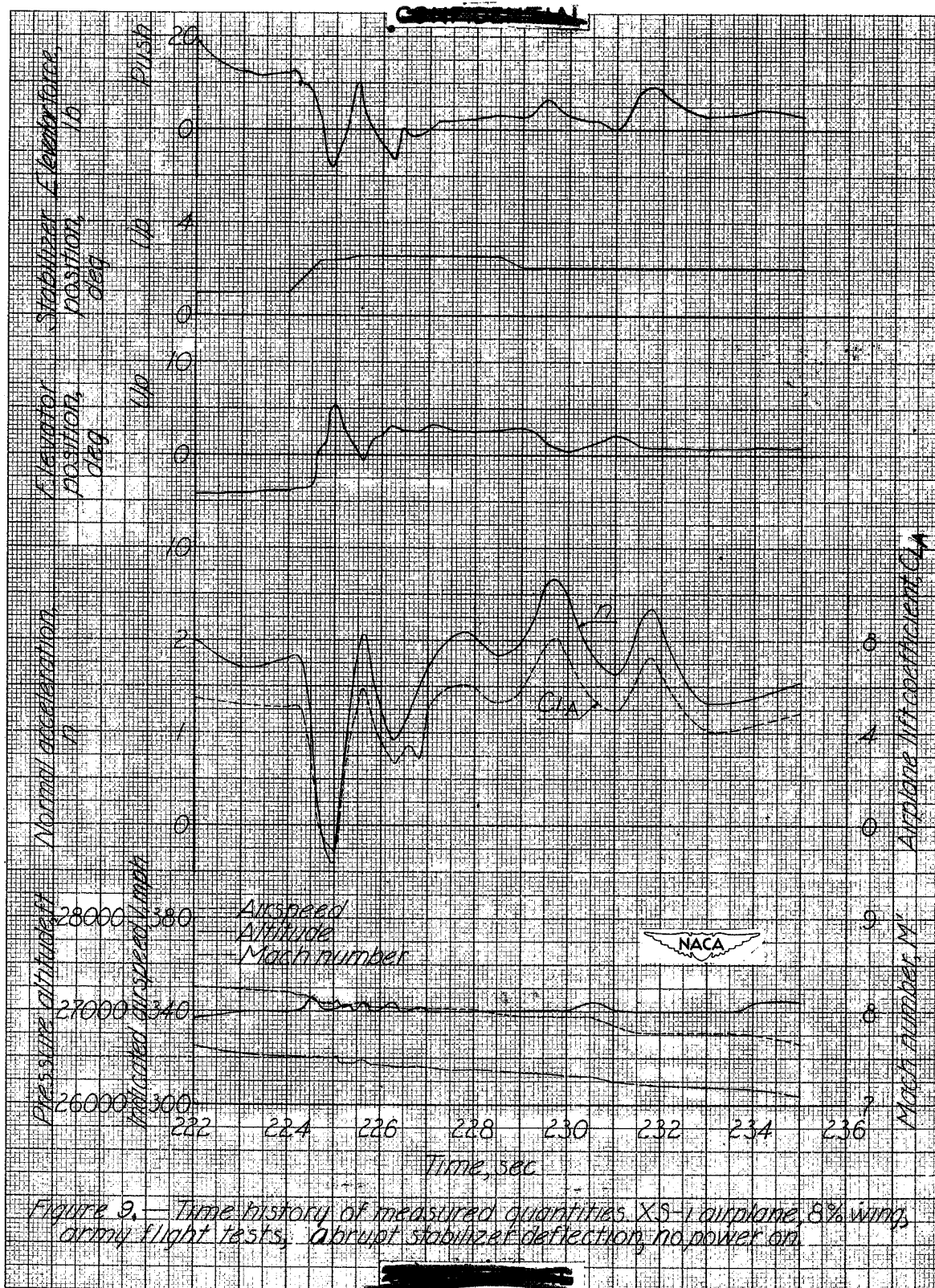
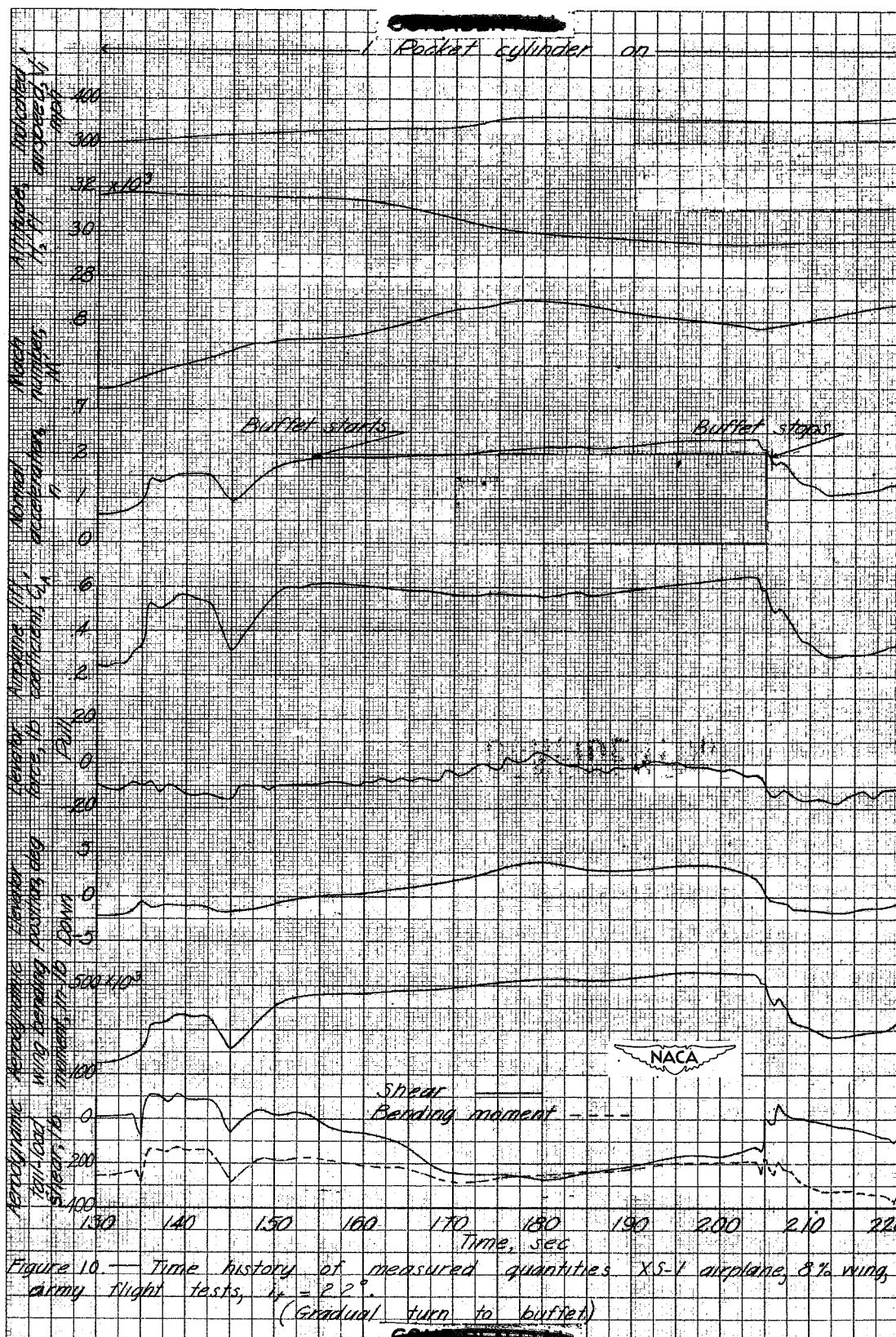
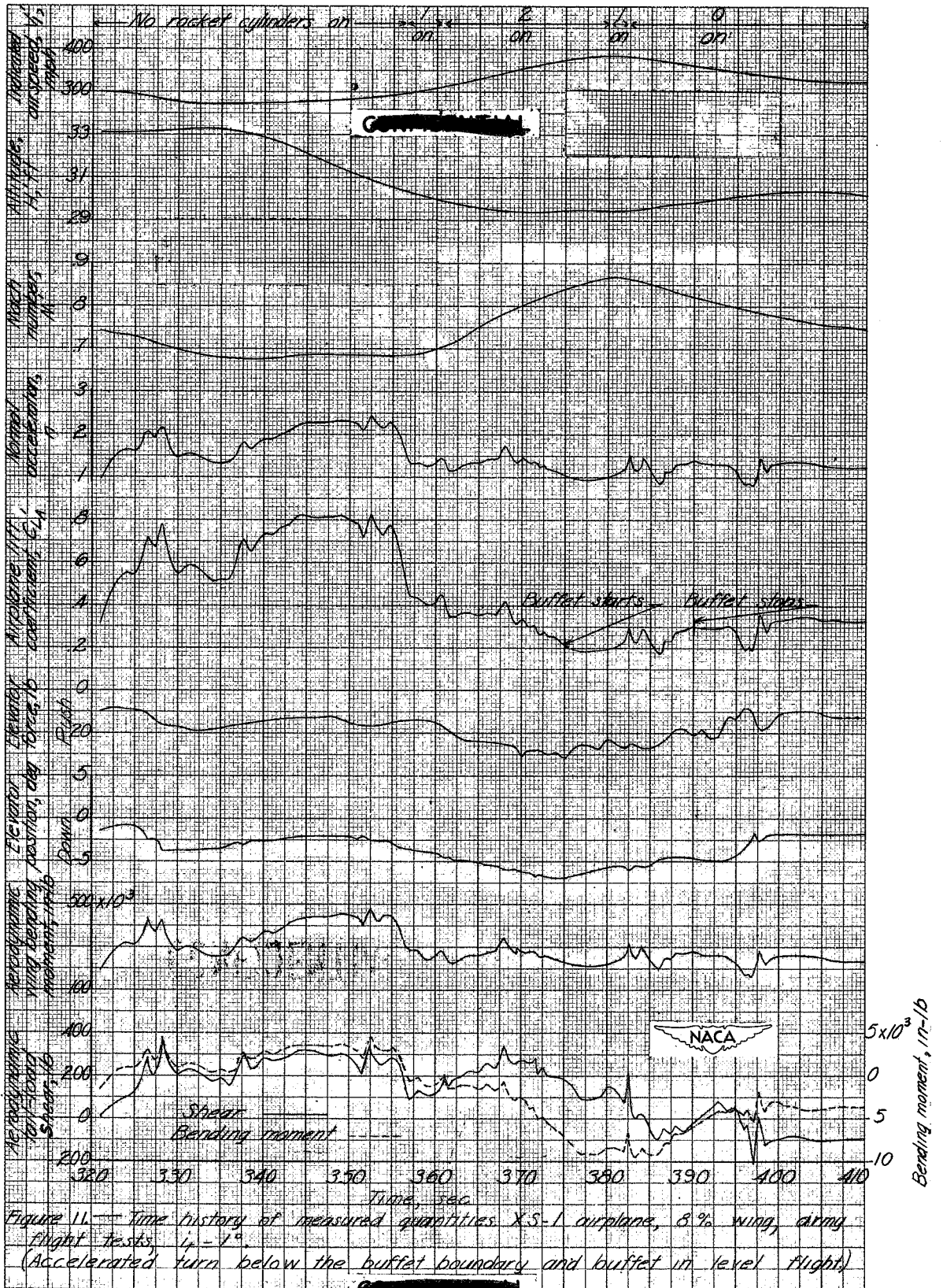

Figure 7. Time history of measured quantities during an unaccelerated stall at high altitude. Wheels and flaps up, X-1 airplane, 8 1/2 wing, Army flight tests.









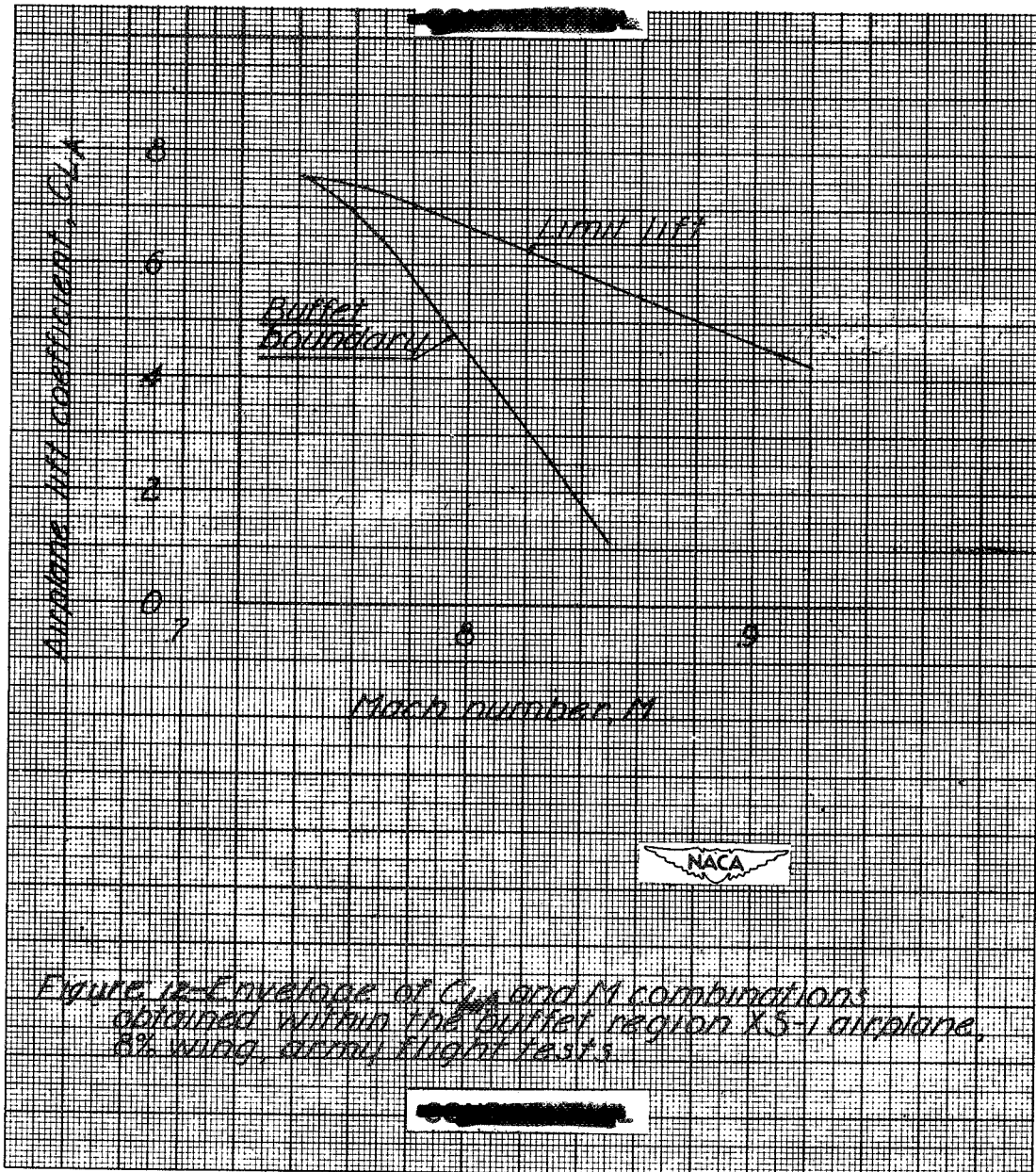

Figure 12-Envelope of C_L and M combinations obtained within the buffer region X-5-1 airplane, 8% wing, army flight tests.

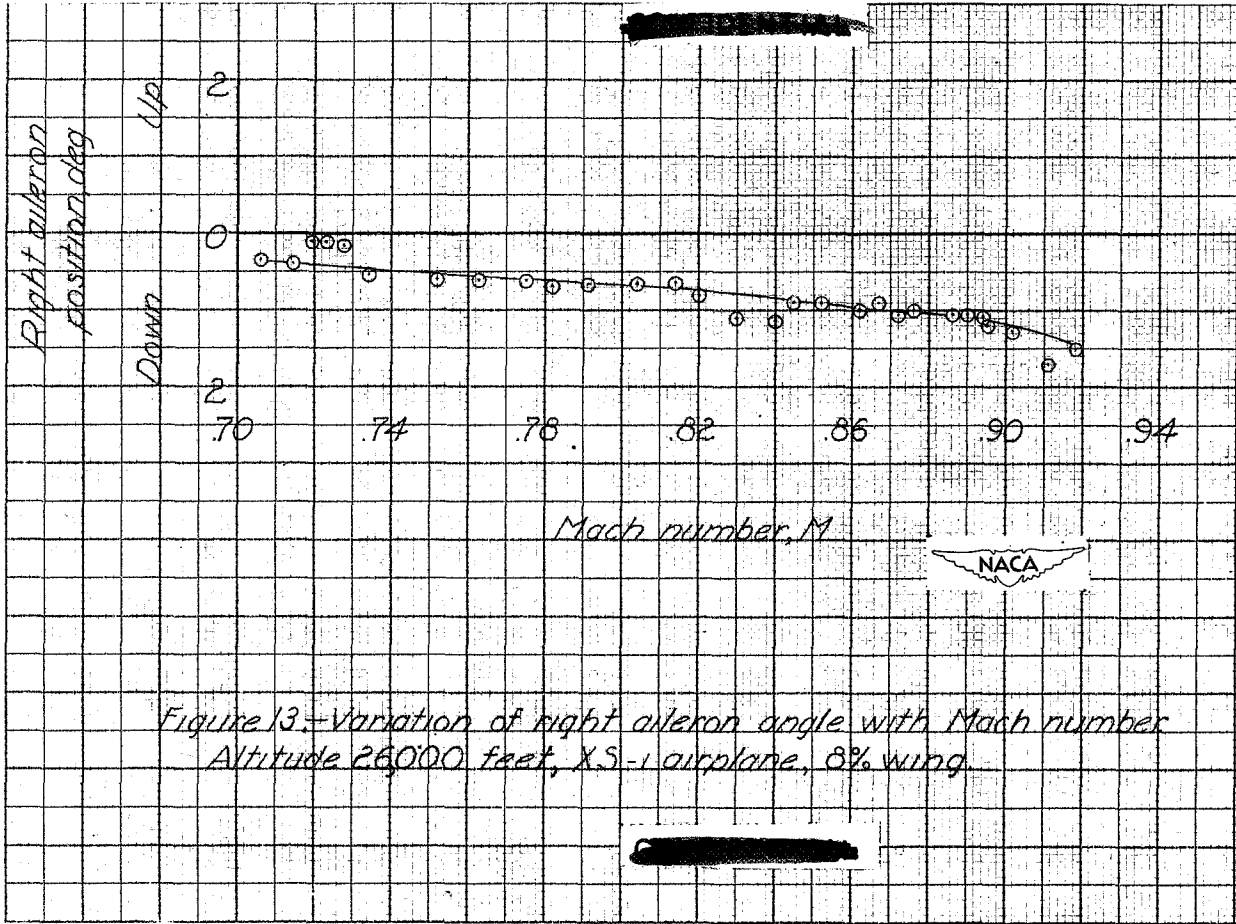

Figure 13.—Variation of right aileron angle with Mach number
 Altitude 26000 feet, X-5-1 airplane, 8% wing.