

CONFIDENTIAL

198
RM No. L8130a

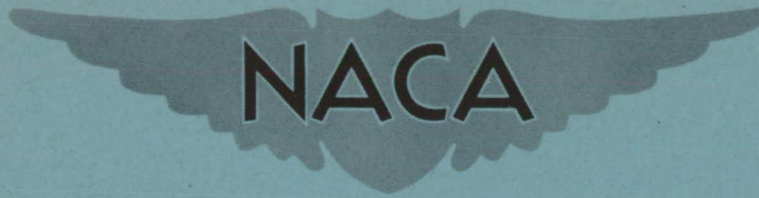

RESEARCH MEMORANDUM

EFFECTS OF A SWEEPBACK HYDROFOIL ON THE FORCE AND
LONGITUDINAL STABILITY CHARACTERISTICS OF A
TYPICAL HIGH-SPEED AIRPLANE

By

Raymond B. Wood

Langley Aeronautical Laboratory
Langley Field, Va.

THIS DOCUMENT ON LOAN FROM THE FILES OF
NATIONAL ADVISORY COMMITTEE FOR AERONAUTICS
LANGLEY AERONAUTICAL LABORATORY
LANGLEY FIELD, HAMPTON, VIRGINIA
RETURN TO THE ABOVE ADDRESS
REQUESTS FOR PUBLICATIONS SHOULD BE ADDRESSED
AS FOLLOWS:
NATIONAL ADVISORY COMMITTEE FOR AERONAUTICS
1512 H STREET, N.W.
WASHINGTON 25, D.C.

CLASSIFICATION CHANGED TO UNCLASSIFIED
CLASSIFIED DOCUMENT

APPROVED BY: J.W. CROWLEY DATE: 9-15-55
CHANGE NO. 3083
WHL

This document contains classified information affecting the national defense of the United States within the meaning of the Espionage Act, USC 50:31 and 32. Its transmission or the revelation of its contents in any manner to an unauthorized person is prohibited by law. Information disclosed hereunder is restricted only to persons in the military and naval services of the United States, appropriate civilian officers and employees of the Federal Government who have a legitimate interest therein, and to United States citizens of known loyalty and discretion who of necessity must be informed thereof.

NATIONAL ADVISORY COMMITTEE FOR AERONAUTICS

WASHINGTON
December 2, 1948

CONFIDENTIAL

NATIONAL ADVISORY COMMITTEE FOR AERONAUTICS

RESEARCH MEMORANDUM

EFFECTS OF A SWEEPBACK HYDROFOIL ON THE FORCE AND
LONGITUDINAL STABILITY CHARACTERISTICS OF A
TYPICAL HIGH-SPEED AIRPLANE

By Raymond B. Wood

SUMMARY

As a part of a program to consider the feasibility of water-based, high-speed airplanes, tests were conducted in the Langley 8-foot high-speed tunnel to determine the effects of a sweptback hydrofoil on the aerodynamic characteristics of a $\frac{1}{16}$ -scale model of the D-558-2 research airplane.

Results indicate that the hydrofoil had little effect on the lift and the static longitudinal stability of the model airplane configuration.

At subsonic speeds, the hydrofoil did not affect the amount of control deflection but did increase the thrust requirements for level-flight sea-level conditions approximately 100 pounds at a Mach number of 0.925. However, increasing the Mach number from 0.95 to 1.20 for level-flight conditions at 35,000 feet caused a 35-percent greater change in pitching moment for the model with the hydrofoil. Approximately 450 pounds more thrust was required for level flight at 35,000 feet at a Mach number of 1.20.

INTRODUCTION

A general program is being conducted by the Langley Aeronautical Laboratory to evaluate the possibilities of using water-based, high-speed airplanes. As a part of this program, an investigation has been made in the Langley 8-foot high-speed tunnel to determine the aerodynamic effects at high speeds of a sweptback hydrofoil on a high-speed airplane. The sweptback hydrofoil as used in this investigation was designed by the Hydrodynamics Division at the Langley Laboratory.

SYMBOLS

V	free-stream velocity, feet per second
ρ	free-stream density, slugs per cubic foot
q	free-stream dynamic pressure, pounds per square foot $\left(\frac{1}{2}\rho V^2\right)$
a	free-stream velocity of sound, feet per second
M	free-stream Mach number $\left(\frac{V}{a}\right)$
L	lift, pounds
D	drag, pounds
m	moment, inch-pounds (taken about center of gravity of airplane)
S_w	wing area, square feet
\bar{c}	mean aerodynamic chord of the wing, inches
C_L	lift coefficient $\left(\frac{L}{qS_w}\right)$
C_D	drag coefficient $\left(\frac{D}{qS_w}\right)$
C_m	pitching-moment coefficient $\left(\frac{m}{qS_w\bar{c}}\right)$
α	angle of attack (fuselage center line), degrees
i_t	angle of incidence of horizontal tail relative to fuselage center line, degrees
δ_e	elevator angle relative to horizontal tail, degrees

APPARATUS

Tunnel

The Langley 8-foot high-speed tunnel is a single-return, closed-throat tunnel. Test sections for both the subsonic-flow and supersonic-flow regions were provided by a liner installed in the tunnel wall. Calibration tests show a uniform velocity in the subsonic model test section, and the Mach number variation in the design $M = 1.2$ supersonic model test region is only ± 0.02 .

Model Support System

The forces on the model were measured by means of an internal strain-gage balance contained within the model as described in reference 1.

Figure 1 shows the model, without the hydrofoil, in the supersonic-flow region. Details of the sting-support system used in this investigation are noted in figure 2.

Model and Hydrofoil

A $\frac{1}{16}$ -scale model of the Douglas D-558-2 research airplane was used for this test. No provisions were made on the fuselage for the flush inlets. Also, the tail-pipe diameter was expanded from 1.25 inches to 1.56 inches to provide sufficient clearances for the internal strain-gage balance system. A three-view drawing of the model is shown in figure 3 and further dimensions for the model are listed in table I.

A 40° sweptback hydrofoil having an NACA 63-010 airfoil section was used for this program. Detail dimensions for the hydrofoil are given in table II.

Notations on figure 4 give the location of the hydrofoil on the airplane. The 25-percent position of the mean aerodynamic chord of the hydrofoil was 1.70 inches forward of the center of gravity. The location measurements used for the Langley 8-foot high-speed-tunnel model were obtained from those used on a similar $\frac{1}{12}$ -scale model tested by the Langley Hydrodynamics Division as the basic model for the hydrofoil program.

TEST PROCEDURE

Methods

All tests with and without the hydrofoil were conducted with the model tail at a constant setting (stabilizer angle $i_t = 1.9^\circ$; elevator deflection $\delta_e = 0^\circ$).

The investigation was conducted at angles of attack of 0° , 2° , -2° , and 4° for a subsonic Mach number range from 0.60 to 0.95 and at a supersonic Mach number of 1.20. Slight deflections of the model under aerodynamic loads, causing small changes in the angle of attack, necessitated an angle measurement at each test point. All moment calculations were made about the center-of-gravity location. The test Reynolds number range was from 1.6 to 1.8 based on the model wing chord. An assumed wing loading of 65 pounds per square foot was used for level-flight calculations.

Corrections

All data presented were corrected to a constant angle of attack. No other corrections were made.

However, as part of the high-speed test program of this model, the interference of the sting on the model forces is being evaluated. Preliminary analysis indicates that this interference is approximately of the magnitude shown as follows:

Force	Subsonic range	M = 1.20
C_m	0.035 to 0.050	0.008
C_L	0	0
C_D	0.005 to 0.010	0.003

Pressure data, taken along the sting behind the model, indicated no change in flow characteristics as a result of adding the hydrofoil to the model. Therefore, the incremental data for the hydrofoil being analyzed probably would not be affected to any appreciable degree by the sting-support system. A similar line of reasoning would also explain the neglect of tunnel-wall corrections. Choking occurred at the model at approximately $M = 0.97$; however, no data were taken at this point.

RESULTS AND DISCUSSION

Pitching Moment and Lift

The variation of pitching-moment coefficient and lift coefficient with Mach number for the complete model, with and without the hydrofoil, is shown in figure 5.

At subsonic speeds, the addition of the hydrofoil to the model had little effect on the lift and moment. Also, there is no shift in the position of the force break for either coefficient.

At $M = 1.20$, the model with the hydrofoil experienced a slight incremental loss of lift and a substantial positive rise in pitching-moment increment. The abrupt change in pitching moment may possibly be due to either a forward shift of the center-of-pressure position caused by the wing-hydrofoil combination or a change in downwash at the tail.

Stability

The variation of pitching-moment coefficient with lift coefficient for the model with and without the hydrofoil is shown for each test Mach number in figure 6.

At all subsonic speeds and at $M = 1.20$, the model with and without the hydrofoil generally had the same degree of static longitudinal stability. The change of control deflection required for level flight for the model with and without the hydrofoil was negligible at subsonic speeds. Increasing the Mach number from 0.95 to 1.20, however, necessitated considerably larger changes in the control deflection required for level flight for the model with the hydrofoil. For instance, at 35,000 feet for level-flight conditions, there was approximately a 35-percent greater change in pitching moment for the model with hydrofoil in going from $M = 0.95$ to $M = 1.20$.

Control difficulties may easily prove to be the critical problem for hydrofoil installation on airplanes expected to fly faster than the speed of sound. This problem is especially critical because of the loss of elevator effectiveness normally experienced in the transonic region. Causes for these changes cannot be evaluated because of the limited and elementary scope of this test.

Drag

The variation of drag coefficient with Mach number for the complete model, with and without the hydrofoil, is shown in figure 7.

The model with the hydrofoil produced small positive incremental drag increases at subsonic speed without indicating any tendency for a shift in the position of the drag force break. At $M = 1.20$, the drag increase due to the addition of the hydrofoil was considerably larger than at lower speeds.

Calculations for level-flight conditions at high subsonic speeds and at $M = 1.20$ indicate greater thrust requirements with the hydrofoil. For instance, for the full-scale airplane for $M = 0.925$ at sea level approximately 100 pounds more thrust would be required; and for $M = 1.20$ at 35,000 feet approximately 450 pounds more thrust would be required.

CONCLUSIONS

At subsonic speeds, the addition of the hydrofoil to the model had little effect on the lift and moment.

The static longitudinal stability for any test Mach number was not appreciably altered by the addition of the hydrofoil. Only negligible differences were indicated in control deflection required for level flight at subsonic speeds because of the hydrofoil. However, increasing the Mach number from 0.95 to 1.20 for level-flight conditions at 35,000 feet caused a 35-percent greater change in pitching moment for the model with the hydrofoil.

Also, the addition of the hydrofoil to the model increased the thrust requirements of the full-scale airplane approximately 100 pounds at a Mach number of 0.925 (sea level) and approximately 450 pounds at a Mach number of 1.20 (35,000 feet) for level-flight conditions.

Langley Aeronautical Laboratory
National Advisory Committee for Aeronautics
Langley Field, Va.

REFERENCE

1. Wright, John B.: High-Speed Wind-Tunnel Tests of a $\frac{1}{16}$ -Scale Model of the D-558 Research Airplane. Basic Longitudinal Stability of the D-558-1. NACA RM No. L7K24, 1948.

TABLE I.-DIMENSIONS OF $\frac{1}{16}$ -SCALE MODEL OF THE DOUGLAS D-558-2 AIRPLANE

Wing root section (normal to 30-percent-chord line)	NACA 63-010
Wing tip section (normal to 30-percent-chord line)	NACA 63 ₁ -012
Wing span, in.	18.76
Wing area, sq ft	0.684
Wing mean aerodynamic chord, in. (Location of 25 percent chord 0.26 in. behind center of gravity)	5.46
Wing sweep angle (30-percent-chord line), deg	35
Wing aspect ratio	3.57
Wing incidence, deg	3
Wing dihedral, deg	3
Wing taper ratio	1.77
Wing geometric twist, deg	0
Wing root chord, in.	6.78
Wing tip chord, in.	3.83
Tail airfoil section (normal to 30-percent-chord line)	NACA 63-010
Tail span, in.	8.98
Tail area, sq ft	0.156
Tail sweep angle (30-percent-chord line), deg	40
Tail aspect ratio	3.59
Tail dihedral, deg	0
Tail root chord, in.	3.35
Tail tip chord, in.	1.68
Elevator area (percent tail area)	25
Fuselage length, in.	31.5
Fuselage maximum diameter, in.	3.75
Fuselage fineness ratio	8.40
Fuselage tail-pipe diameter, in. (8-foot high-speed-tunnel model).	1.56



TABLE II.-HYDROFOIL DIMENSIONS

Hydrofoil section	NACA 63-010
Hydrofoil aspect ratio	3.06
Hydrofoil taper ratio	1.40
Hydrofoil span, in.	5.25
Hydrofoil area, sq ft	0.0627
Hydrofoil mean aerodynamic chord, in. (Location of 25-percent chord 1.70 in. forward of center of gravity)	1.78
Hydrofoil incidence, deg	2
Hydrofoil dihedral, deg	0
Hydrofoil sweep angle (leading edge), deg	40
Hydrofoil root chord, in.	2.0
Hydrofoil tip chord, in.	1.43
Hydrofoil strut section	NACA 66-010
Hydrofoil strut sweep angle (leading edge), deg	45
Hydrofoil strut root chord, in.	1.50
Hydrofoil strut tip chord, in.	1.50
Hydrofoil strut area, sq ft	0.0148



CONFIDENTIAL

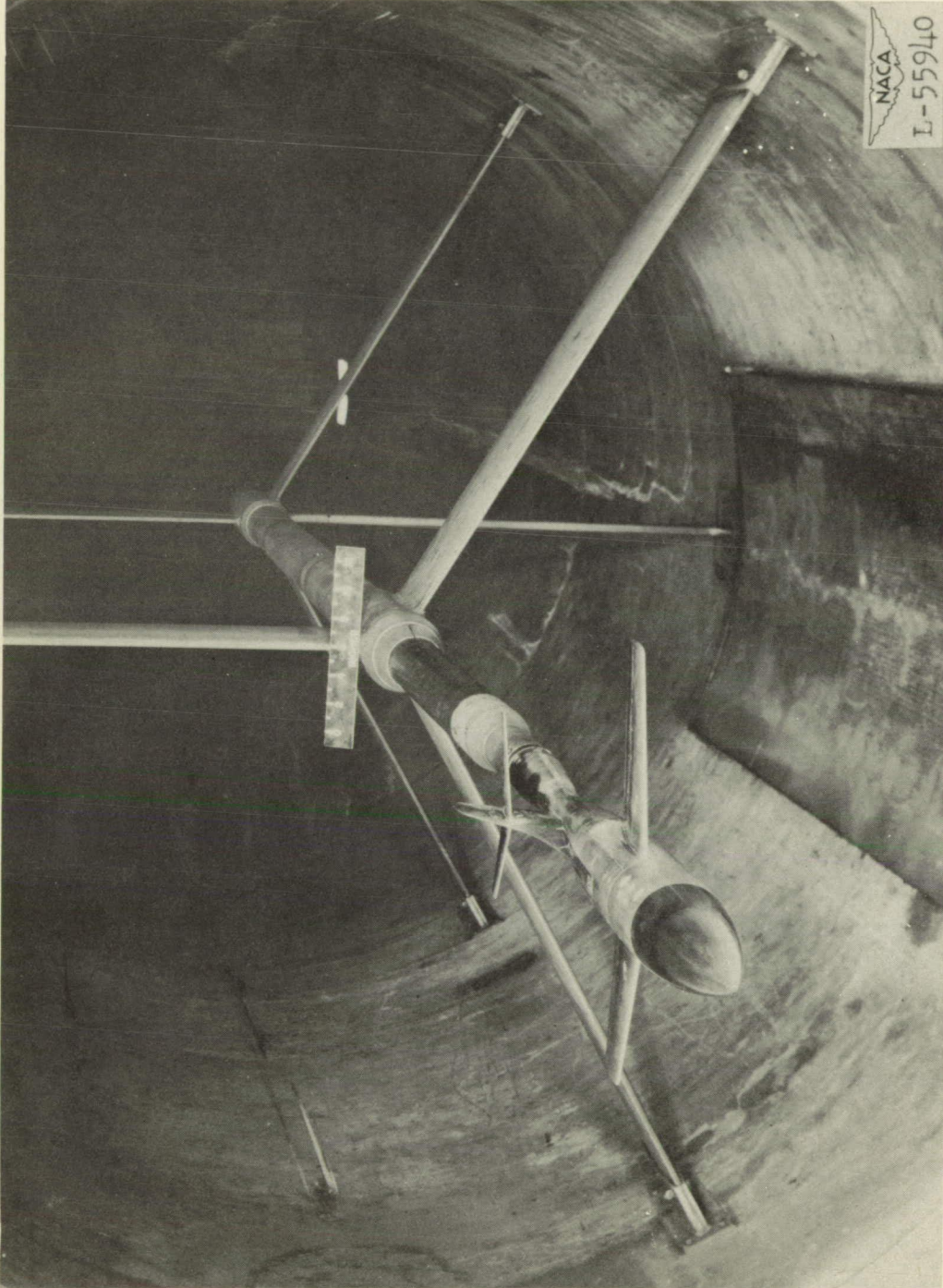

Figure 1.- Photograph of $\frac{1}{10}$ -scale model of the Douglas D-558-2 in the Langley 8-foot high-speed tunnel.

CONFIDENTIAL

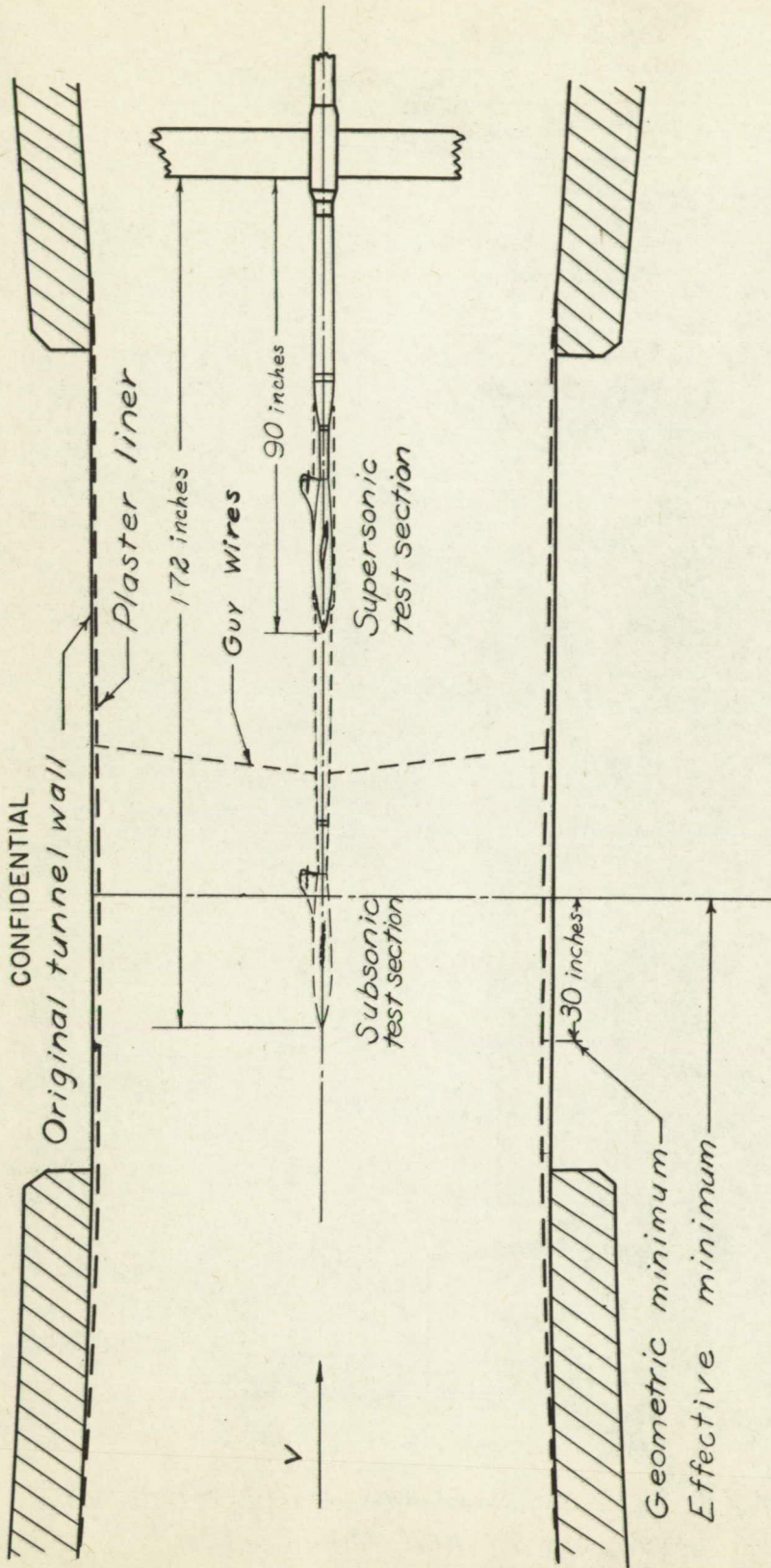

Figure 2.— Approximate shape and dimensions for model location of the D-558-2 in the M=1.2 temporary nozzle installed as a plaster liner in the Langley 8-foot high-speed tunnel.

CONFIDENTIAL

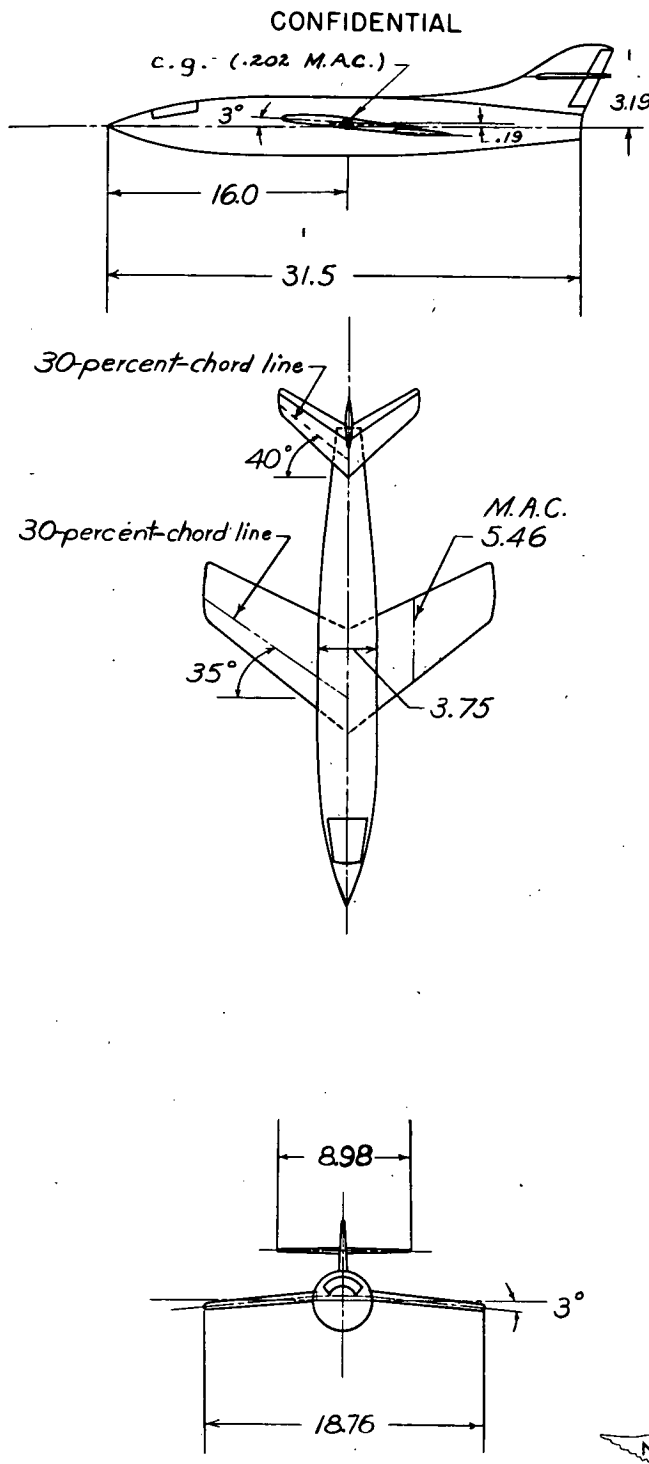

Figure 3.- Drawing of the $\frac{1}{16}$ - scale model of the D-558-2 as tested in the Langley 8-foot high-speed tunnel. (All dimensions in inches)

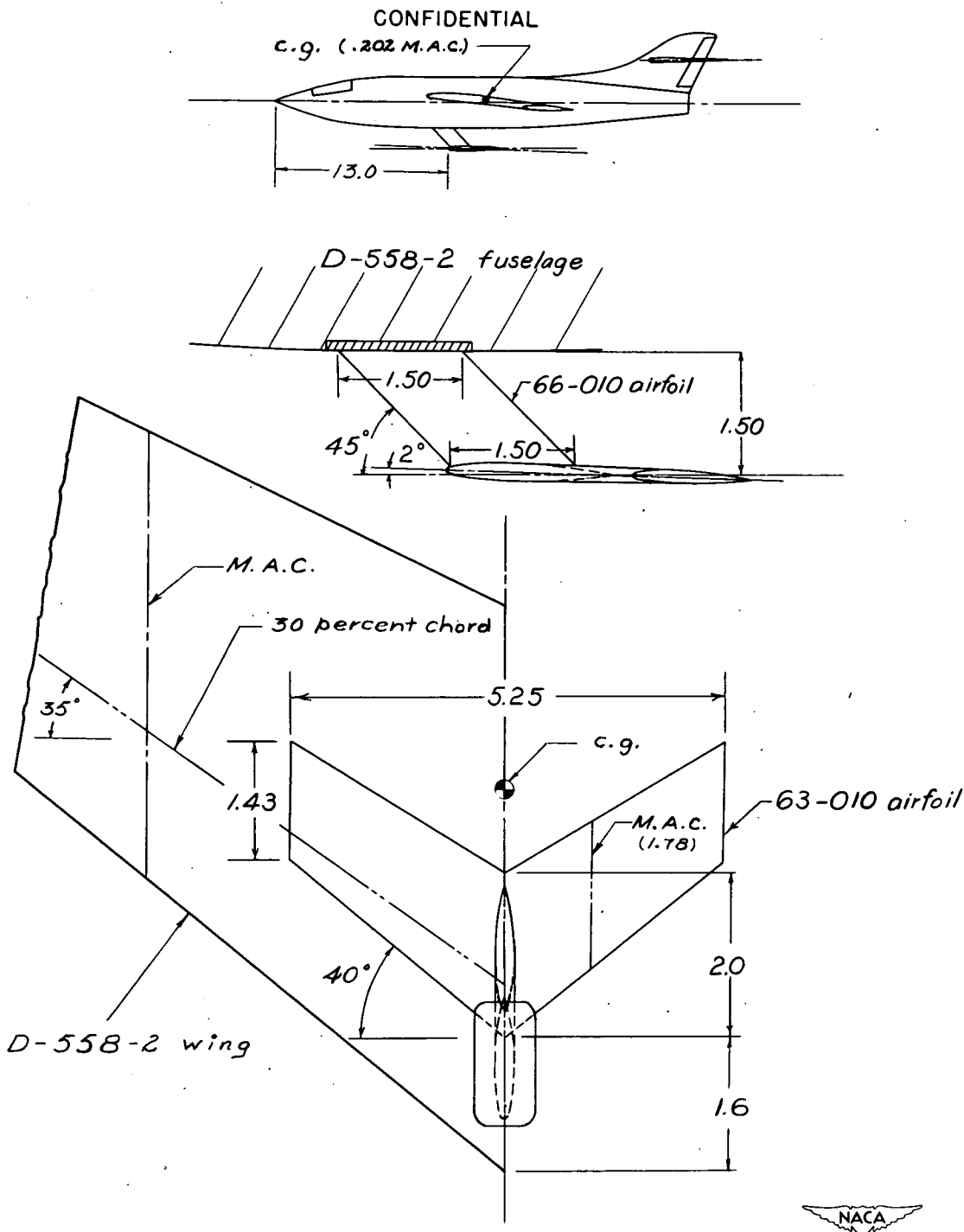

Figure 4.- Drawing of the hydrofoil and installation of the hydrofoil on the $\frac{1}{16}$ -scale model of the D-558-2. (All dimensions in inches)

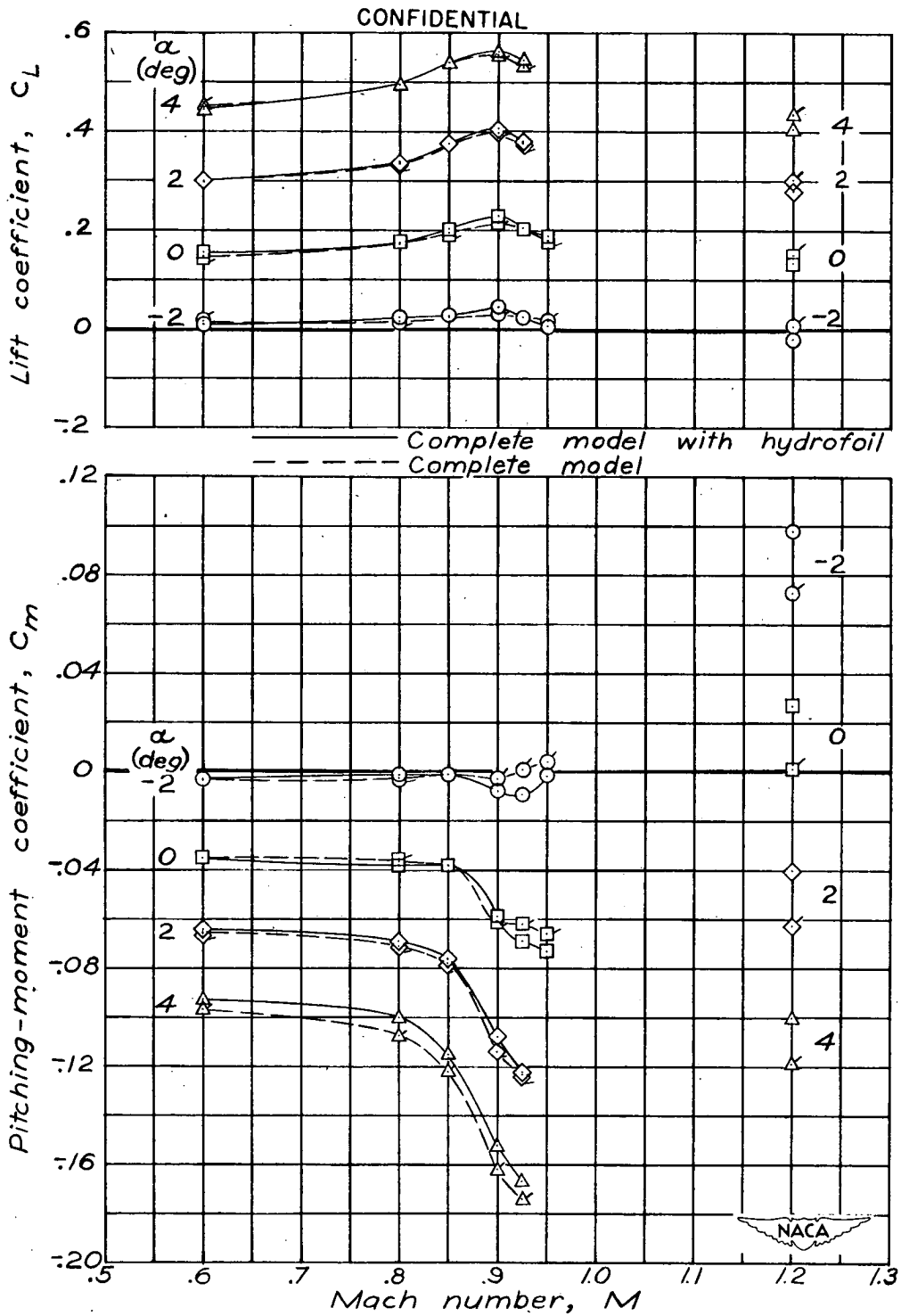

Figure 5.— Variation of lift coefficient and pitching-moment coefficient with Mach number for constant angles of attack. (The plain symbols refer to the complete model with hydrofoil and the flagged symbols refer to the complete model.) $i_T = 1.9^\circ$; $\delta_e = 0^\circ$.

CONFIDENTIAL

———— Complete model with hydrofoil
 - - - - Complete model

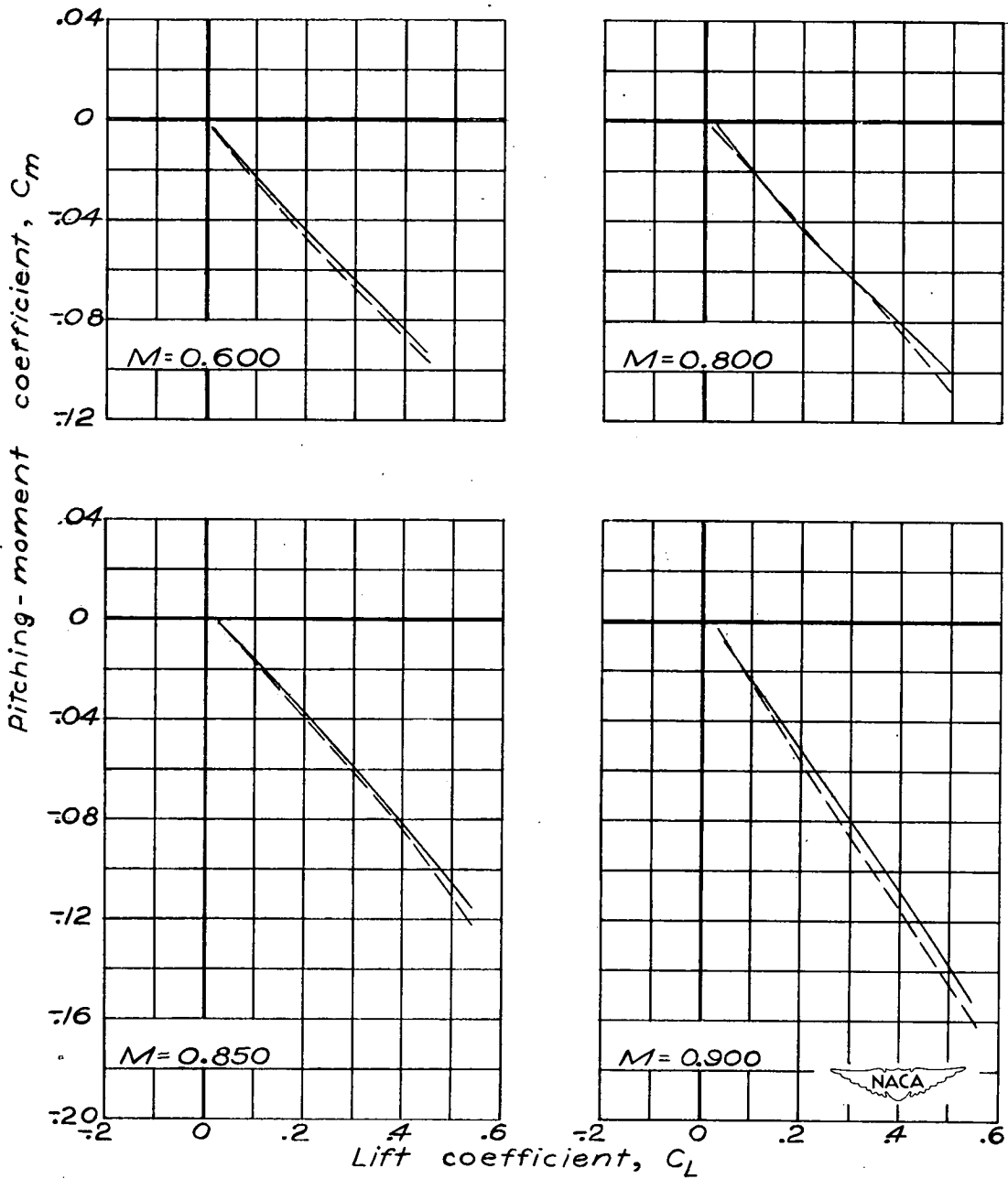

Figure 6. — Variation of pitching-moment coefficient with lift coefficient for various Mach numbers, for complete model and complete model with hydrofoil. $i_f = 1.9^\circ$; $\delta_e = 0^\circ$.

CONFIDENTIAL

CONFIDENTIAL

— Complete model with hydrofoil
 - - - Complete model

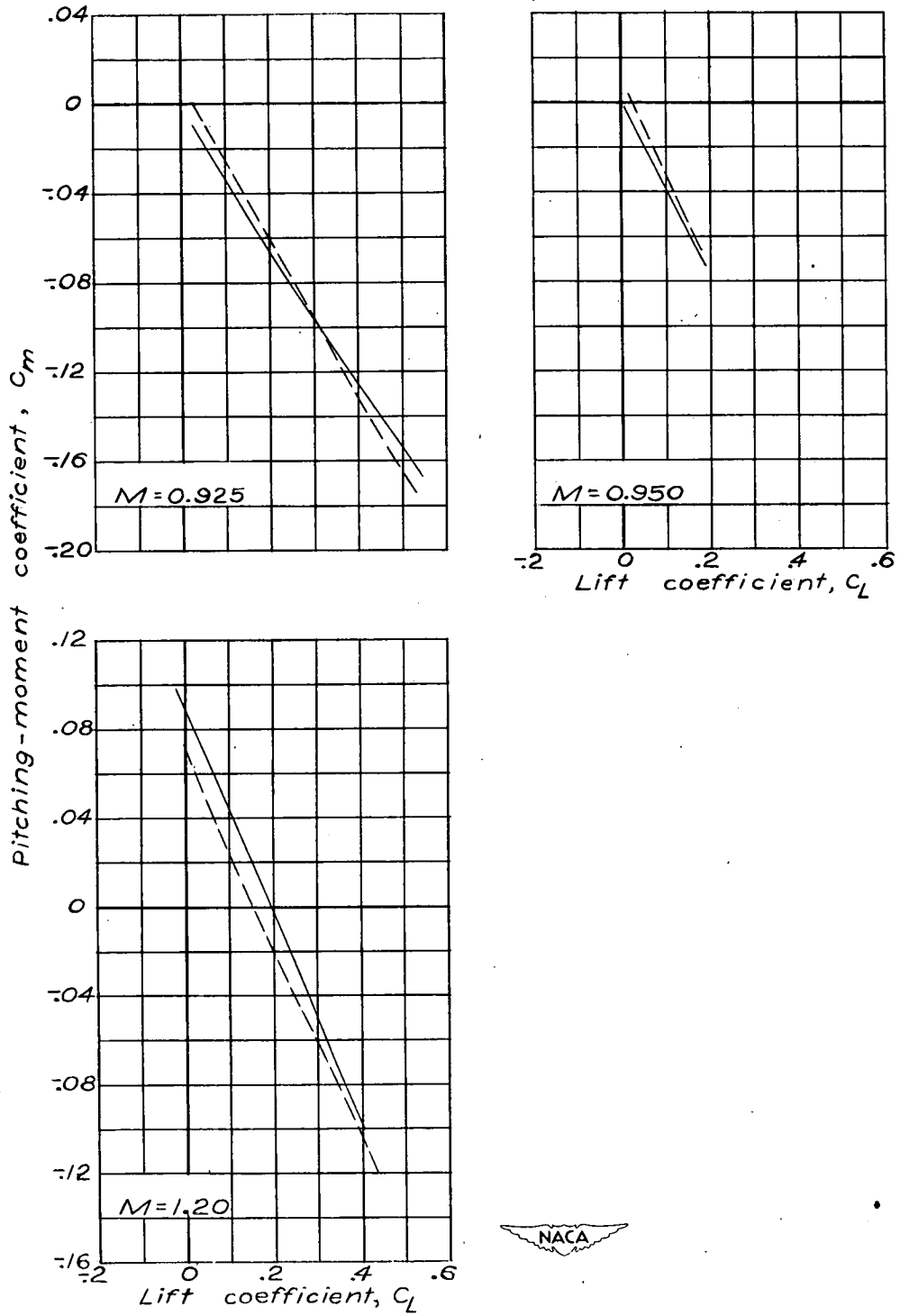

Figure 6. - Concluded.
 CONFIDENTIAL

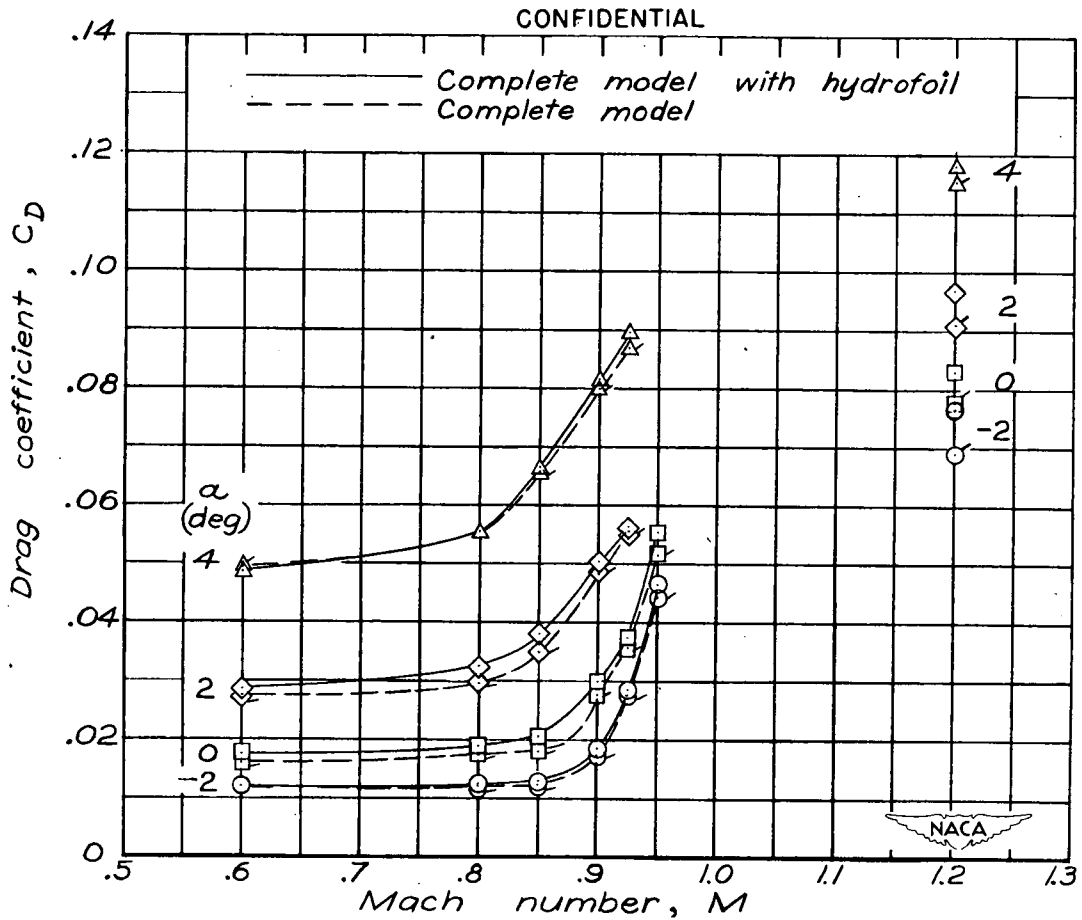

Figure 7.— Variation of drag coefficient with Mach number for constant angles of attack. (The plain symbols refer to the complete model with hydrofoil and the flagged symbols refer to the complete model.) $i_f = 1.9^\circ$; $\delta_e = 0^\circ$.